



**SCHOOL FACILITIES MANAGEMENT
CONTRACT MANUAL AND SPECIFICATIONS**

for the

**PROJECT NAME: CONSTRUCTION OF COMMUNITY SCHOOL 35
SCHOOL NAME: COMMUNITY SCHOOL 35**

BID NO. IFB - 6711

SED # 66-23-00-01-0-346-001

<u>Contract 1 - General Construction</u>	<u>Contract 2 - Plumbing Work</u>
<u>Contract 3 - HVAC Work</u>	<u>Contract 4 - Electrical Work</u>

YONKERS JOINT SCHOOLS CONSTRUCTION BOARD

- | | |
|--|--|
| Hon. Mike Spano, Mayor of the City of Yonkers | Ronald Matten, Yonkers City Council Minority Designee |
| Rev. Steve Lopez, President of Yonkers Public Schools Board of Education | Pastor James Hassell, Joint Designee of the Mayor and Superintendent |
| Dr. Edwin M. Quezada, Superintendent of Yonkers Public Schools | Hon. Andrew J. Spano, Joint Designee of the Mayor and Superintendent |
| Roberto Rijos, Yonkers Council of PTAs Designee | Steven Frey, Joint Designee of the Mayor and Superintendent |
| Miguel A. Cuevas, Yonkers City Council Majority Designee | |

Prepared by:

ARCHITECT
KG+D Architects, P.C.
285 Main Street
Mount Kisco, NY 10549

SPECIFICATIONS
Sue McClymonds
2 Robb Road
Amsterdam, New York 12010

CIVIL ENGINEER
Insite Engineering, Surveying & LA, PC
3 Garrett Place
Carmel, NY 10512

STRUCTURAL ENGINEER
The DiSalvo Engineering Group
83 Wooster Heights Road, Suite 200
Danbury, CT 06810

SYSTEMS ENGINEER
Barile Gallagher & Associates
39 Marble Ave.
Pleasantville, NY 10507

FOOD SERVICE CONSULTANT
Clevenger Frable & Lavallee, Inc.
39 Westmoreland Ave.
White Plains, NY 10606

Index to Technical Portion of the
Project Manual/Specifications

For

YONKERS JOINT SCHOOLS CONSTRUCTION BOARD

COMMUNITY SCHOOL 35
121 McLean Ave.
Yonkers, NY 10705

VOLUME 1

DIVISION 00 – PROCUREMENT AND CONTRACTING REQUIREMENTS

000001	INDEX TO SPECIFICATIONS
000110	YJSCB INFORMATION FOR BIDDERS COVER SHEET AND ADVERTISEMENT FOR BIDS
002000	INSTRUCTIONS TO BIDDERS
003000	INFORMATION AVAILABLE FOR BIDDERS
003132	GEOTECHNICAL REPORT
004010	BID FORM - CONTRACT NO. 1 - GENERAL CONSTRUCTION WORK
004011	BID BREAKDOWN SCHEDULE OF VALUES - CONTRACT NO. 1 - GENERAL CONSTRUCTION WORK
004020	BID FORM - CONTRACT NO. 2 - PLUMBING AND FIRE PROTECTION WORK
004021	BID BREAKDOWN SCHEDULE OF VALUES - CONTRACT NO. 2 - PLUMBING AND FIRE PROTECTION WORK
004030	BID FORM - CONTRACT NO. 3 - HVAC WORK
004031	BID BREAKDOWN SCHEDULE OF VALUES - CONTRACT NO. 3 - HVAC WORK
004040	BID FORM - CONTRACT NO. 4 - ELECTRICAL WORK
004041	BID BREAKDOWN SCHEDULE OF VALUES - CONTRACT NO. 4 - ELECTRICAL WORK
004110	CERTIFICATION OF COMPLIANCE WITH THE IRAN DIVESTMENT ACT
004120	CERTIFICATE OF COMPLIANCE WITH THE MACBRIDE PRINICIPLES
004130	YONKERS JOINT SCHOOLS CONSTRUCTION BOARD BID PACKAGE DIVERSIFICATION DOCUMENTS
004131	YJSCB BID PACKAGE DIVERSIFICATION GOOD FAITH EFFORTS CHECKLIST
004140	CITY OF YONKERS VENDOR BACKGROUND QUESTIONNAIRE
004150	CITY OF YONKERS BIDDERS AFFIDAVIT
004200	STATEMENT OF CONTRACTOR'S APPRENTICESHIP PROGRAM COMPLIANCE
004300	BID BOND - AIA DOCUMENT A310 – 2010
004331	<u>DIVERSITY PLAN AND RIDER (MWBE Utilization and Workforce Diversity)</u>
004500	STATEMENT OF BIDDER'S QUALIFICATIONS - AIA DOCUMENT A305 -2020
004501	EXHIBIT A TO AIA DOCUMENT A305 – GENERAL INFORMATION
004502	EXHIBIT B TO AIA DOCUMENT A305 – FINANCIAL AND PERFORMANCE INFORMATION
004503	EXHIBIT C TO AIA DOCUMENT A305 – PROJECT SPECIFIC INFORMATION
004504	EXHIBIT D TO AIA DOCUMENT A305 – CONTRACTOR'S PAST PROJECT EXPERIENCE
004505	EXHIBIT E TO AIA DOCUMENT A305 – CONTRACTOR'S PAST PROJECT EXPERIENCE, CONTINUED

005000 OWNER-CONTRACTOR AGREEMENT – AIA DOCUMENT A132 – 2019
007000 GENERAL CONDITIONS OF THE CONTRACT AIA DOCUMENT A232 – 2019
007001 OWNER’S INSURANCE REQUIREMENTS
007100 PERFORMANCE BOND - AIA DOCUMENT A312 - 2010
007200 PAYMENT BOND - AIA DOCUMENT A312 – 2010
007300 YONKERS JOINT SCHOOLS CONSTRUCTION BOARD MINORITY AND WOMAN-
OWNED BUSINESS ENTERPRISE AND WORKFORCE UTILIZATION FORMS
003132 GEOTECHNICAL REPORT
008700 WAGE RATE ATTACHMENTS

DIVISION 01 - GENERAL REQUIREMENT

011010 MULTIPLE CONTRACT SUMMARY
011020 MILESTONE SCHEDULE
011500 SPECIAL PROJECT REQUIREMENTS/ADMINISTRATIVE REQUIREMENTS
012100 ALLOWANCES
012300 ALTERNATES
012500 PRODUCT OPTIONS AND SUBSTITUTIONS
012501 SUBSTITUTION REQUEST FORM
012900 APPLICATIONS FOR PAYMENT
012901 PAYROLL CERTIFICATION
012902 WAIVER OF LIENS-KGD FORM
013113 PROJECT COORDINATION AND ATTACHED SCHEDULE
013114 COORDINATION DRAWINGS AND PROCEDURES
013115 RFI REQUIREMENTS
013116 RFI FORM
013119 PROJECT MEETINGS
013200 SCHEDULING AND PROGRESS
013300 SUBMITTAL REQUIREMENTS
013301 REQUEST FOR ELECTRONIC FILES/CAD FILE PROTOCOLS
013302 RELEASE FOR BIM FILES
013303 SUBMITTAL COVER SHEET
013306 CERTIFICATION OF SPECIFICATION COMPLIANCE
013529 HEALTH AND SAFETY PLAN (HASP)
014100 PERMITS AND COMPLIANCE
014219 CODES AND STANDARDS
014326 TESTING LABORATORY SERVICES
014329 STATEMENT OF SPECIAL INSPECTIONS
014339 MOCKUP REQUIREMENTS
015000 TEMPORARY FACILITIES
015713 TEMPORARY EROSION AND SEDIMENT CONTROL
015719 ENVIRONMENTAL PROTECTION DURING CONSTRUCTION
016100 MATERIAL AND EQUIPMENT
017123 FIELD ENGINEERING
017419 CONSTRUCTION WASTE MANAGEMENT
017700 PROJECT CLOSE OUT
017719 PROJECT RECORD DOCUMENTS
017823 OPERATION AND MAINTENANCE REQUIREMENTS
017836 GUARANTEES, WARRANTIES AND BONDS – SEE INDIVIDUAL SECTIONS

DIVISION 02 – EXISTING CONDITIONS – Not used

DIVISION 03 – CONCRETE

033000 CAST-IN PLACE CONCRETE

DIVISION 04 - MASONRY

042000 UNIT MASONRY
044100 STONE MASONRY VENEER
047200 CAST STONE

DIVISION 05 – METALS

051200 STRUCTURAL STEEL FRAMING
053100 STEEL DECKING
054000 COLD-FORMED METAL FRAMING
055000 METAL FABRICATIONS

DIVISION 06 - WOOD, PLASTICS, AND COMPOSITES

060001 MILLWORK SCHEDULE
061053 MISCELLANEOUS ROUGH CARPENTRY
061643 GYPSUM SHEATHING
064020 INTERIOR ARCHITECTURAL WOODWORK
066116 SOLID SURFACE MATERIAL FABRICATIONS

DIVISION 07 - THERMAL AND MOISTURE PROTECTION

071326 SELF-ADHERING SHEET WATERPROOFING
072100 THERMAL INSULATION
072419 WATER-DRAINAGE EXTERIOR INSULATION AND FINISH SYSTEM (EIFS)
072726 FLUID-APPLIED MEMBRANE AIR BARRIERS
074114 METAL FACED INSULATING GLAZING PANELS
074213.53 COMPOSITE METAL WALL AND SOFFIT PANELS
075323 ETHYLENE-PROPYLENE-DIENE-MONOMER (EPDM) ROOFING
076200 SHEET METAL FLASHING, FABRICATIONS AND TRIM
076223 SHEET METAL SIDING
077200 ROOF ACCESSORIES
077273 VEGETATED ROOF SYSTEMS
078100 APPLIED FIREPROOFING
078123 INTUMESCENT MASTIC FIREPROOFING
078413 PENETRATION FIRESTOPPING
078446 FIRE-RESISTIVE JOINT SYSTEMS
079200 JOINT SEALANTS

079500 EXPANSION CONTROL

DIVISION 08 - OPENINGS

081113 HOLLOW METAL DOORS AND FRAMES
081416 FLUSH WOOD DOORS
082250 POLYESTER FACED DOORS AND ALUMINUM FRAMING
083113 ACCESS DOORS AND FRAMES
083326 OVERHEAD COILING DOORS
083329 OVERHEAD COILING GRILLES
083450 ELEVATOR DOOR SMOKE CONTAINMENT SYSTEM
084113 ALUMINUM ENTRANCES AND STOREFRONTS
084133 FOLDING GLASS STOREFRONTS
084413 GLAZED ALUMINUM CURTAIN WALLS
085656 TRANSACTION WINDOWS
086200 UNIT SKYLIGHTS
086300 METAL-FRAMED SKYLIGHTS
087100 DOOR HARDWARE
088000 GLAZING
089000 LOUVERS AND VENTS

DIVISION 09 - FINISHES

092116.23 GYPSUM BOARD SHAFT WALL ASSEMBLIES
092216 NON-STRUCTURAL METAL FRAMING
092800 GLASS-REINFORCED GYPSUM FABRICATIONS
092900 GYPSUM BOARD
093100 CERAMIC TILING
095113 ACOUSTICAL PANEL CEILINGS
095116 ACOUSTICAL BOARD CEILING PANELS
095429 WOOD PANEL ACOUSTICAL CEILING SYSTEMS
096466 WOOD ATHLETIC FLOORING
096500 RESILIENT FLOORING AND ACCESSORIES
096623 RESINOUS MATRIX TERRAZZO FLOORING
096813 TILE CARPETING
097750 FIBERGLASS REINFORCED PLASTIC PANELS
098413 ACOUSTICAL WALL PANELS
099100 PAINTING
099101 PAINTING LIST

DIVISION 10 - SPECIALTIES

101000 VISUAL DISPLAY SURFACES
101200 DISPLAY CASES
101400 SIGNAGE
102113 TOILET COMPARTMENTS
102226 OPERABLE PARTITIONS

102800	TOILET AND BATH ACCESSORIES
102900	MEDICAL ACCESSORIES
105113	METAL LOCKERS
105200	FIRE PROTECTION SPECIALTIES
105213	AUTOMATED EXTERNAL DEFIBRILLATOR (AED) SPECIALTIES
105316	CANOPIES

DIVISION 11 – EQUIPMENT

110633	STAGE CURTAINS AND RIGGING
111319	STATIONARY LOADING DOCK EQUIPMENT
113100	RESIDENTIAL APPLIANCES
114000	FOOD SERVICE EQUIPMENT
114900	GYMNASIUM EQUIPMENT
115213	PROJECTION SCREENS
116814	PLAYGROUND SURFACING
116843	SCOREBOARDS AND ACCESSORIES

DIVISION 12 - FURNISHINGS

120001	CASEWORK SCHEDULE
122413	ROLLER WINDOW SHADES
122413a	WINDOW SHADE TYPES SCHEDULE
123553.19	WOOD LABORATORY CASEWORK
123559	INSTITUTIONAL CASEWORK
123661	SIMULATED STONE COUNTERTOPS
124813	ENTRANCE FLOOR MATS AND FRAMES
126600	TELESCOPING STANDS

DIVISION 13 – SPECIAL CONSTRUCTION – not used

DIVISION 14 – CONVEYING SYSTEMS

142100	ELECTRIC TRACTION ELEVATORS
144200	WHEELCHAIR LIFTS

DIVISION 15 – 21 – not used

END OF VOLUME 1

VOLUME 2

DIVISION 22 – PLUMBING

220100	GENERAL CONDITIONS
220125	SCOPE OF WORK
220130	WATER SUPPLY SYSTEM
220150	SANITARY, STORM AND ACID WASTE DRAINAGE SYSTEMS
220180	NEW GAS SERVICE, STREET CONNECTIONS AND ASSOCIATED WORK
220200	MAGNETICALLY COUPLED PACKAGED GAS BOOSTER SYSTEM
220300	PLUMBING FIXTURES AND EQUIPMENT
220310	BACKFLOW PREVENTERS
220320	DOMESTIC HOT WATER GAS-FIRED HEATING EQUIPMENT
220370	SPRINKLER SYSTEM
220380	AUTOMATIC FIRE PUMP-COMBINATION SYSTEM STANDPIPE AND SPRINKLERS
220420	SUPPORTS, SLEEVES AND PLATES
220430	INSULATION
220470	TESTS AND ADJUSTMENTS
220480	TAGS, CHARTS AND IDENTIFICATION
220490	GUARANTEE

DIVISION 23 – MECHANICAL

230100	GENERAL CONDITIONS
230110	SCOPE OF WORK
230140	DIESEL ENGINE EXHAUST
230190	PUMPS
230195	DIESEL FUEL SYSTEM
230200	HYDRONIC SPECIALTIES
230234	INDOOR ENTHALPY WHEEL ENERGY RECOVERY UNITS
230235	INDOOR FIXED PLATE ENERGY RECOVERY UNITS
230236	PACKAGED ROOFTOP ENERGY RECOVERY UNITS
230237	PACKAGED ROOFTOP FIXED PLATE ENERGY RECOVERY UNITS
230255	VARIABLE REFRIGERANT FLOW OUTDOOR UNITS
230260	DUCTLESS SPLIT SYSTEMS
230265	VARIABLE REFRIGERANT FLOW INDOOR UNITS
230270	VRF REFRIGERANT TO WATER HEAT EXCHANGERS
230280	VARIABLE FREQUENCY DRIVES
230290	DUCT MOUNTED COILS
230300	FANS
230310	HOT WATER CABINET HEATERS
230320	HOT WATER UNIT HEATERS
230325	CEILING RADIANT PANEL HEATERS
230330	CONVECTORS
230340	FIN TUBE RADIATION
230343	AIR CURTAINS
230400	SHEETMETAL WORK AND RELATED ACCESSORIES

230405	UNDERGROUND DUCTWORK
230410	PIPING, FITTINGS, VALVES AND NOTES (HOT WATER)
230420	SUPPORTS, SLEEVES AND PLATES
230430	INSULATION AND COVERINGS
230440	DAMPERS AND MISCELLANEOUS
230460	AUTOMATIC TEMPERATURE CONTROLS
230470	TESTING, START-UP AND ADJUSTMENTS
230480	GENERAL LABELING, VALVE CHARTS AND PIPING IDENTIFICATION
230485	HVACSYSTEMS COMMISSIONING
230490	GUARANTEE

DIVISION 26 – ELECTRICAL

260100	GENERAL CONDITIONS
260125	SCOPE OF WORK
260150	APPROVED MANUFACTURERS
260200	CONDUIT
260250	DUCT BANK
260300	WIRE AND CABLE
260320	OVERCURRENT PROTECTIVE DEVICES
260350	BOXES
260400	WIRING DEVICES
260425	DIGITAL LIGHTING CONTROL SYSTEM
260450	CABINETS AND ENCLOSURES
260500	SUPPORTING DEVICES
260550	GENERAL LABELING AND IDENTIFICATION
260575	INTERIOR LUMINAIRES
260580	THEATRICAL LIGHTING AND CONTROLS
260585	RIGGING
260595	QUICKTOUCH FIXED SPEED CONTROL SYSTEM
260600	DISCONNECT SWITCHES
260650	GROUNDING
260700	PANELBOARDS
260725	SWITCHBOARD
260750	ELECTRIC SERVICE
260775	SURGE PROTECTIONS DEVICES
260785	AUTOMATIC TRANSFER SWITCH
260800	FIRE ALARM SYSTEM
260810	TELECOMMUNICATIONS AND AUDIO/VIDEO CABLING SYSTEM
260820	FIBER OPTIC CABLING SYSTEM
260825	PUBLIC ADDRESS SYSTEM
260830	XR WIRELESS CLOCKS SYSTEM
260850	AUDITORIUM/GYM SOUND SYSTEM
260860	RESCUE ASSISTANCE
260875	PACKAGED ENGINE GENERATOR SYSTEM – DIESEL INDOOR
260880	PHOTOVOLTAIC SYSTEM
260890	ELECTRICAL SYSTEMS COMMISSIONING
260900	GUARANTEE

DIVISION 28 – ELECTRONIC SAFETY AND SECURITY

280000 SECURITY SYSTEMS GENERAL CONDITIONS

DIVISION 31 – EARTHWORK

311000	SITE CLEARING
312000	EARTH MOVING
312316.26	ROCK REMOVAL
312319	DEWATERING
312333	TRENCHING & BACKFILLING
312500	EROSION & SEDIMENT CONTROL
315000	EVACUATION SUPPORT & PROTECTION

DIVISION 32 – EXTERIOR IMPROVEMENTS

321216	ASPHALT PAVING
321816	PLAYGROUND SURFACING
323113	CHAIN LINK FENCE
323119	ORNAMENTAL METAL FENCING AND GATES
329200	TURFS & GRASSES

DIVISION 33 – UTILITIES

331400	WATER UTILITY TRANSMISSION & DISTRIBUTION
333000	SANITARY SEWERAGE
331400	STORM UTILITY DRAIN PIPING
334600	SUBDRAINAGE

****End of Index****

**YONKERS JOINT SCHOOLS CONSTRUCTION BOARD (“YJSCB”)
 INFORMATION FOR BIDDERS COVER SHEET
 AND ADVERTISEMENT FOR BIDS**

1. Bid No.: IFB-6711
2. Description: New Construction of Community School 35
3. Place of Performance: 121 McLean Avenue
Yonkers, NY 10705
4. Date, Time, and Place Bids are Due:

Date:	FRIDAY, DECEMBER 10, 2021
Time:	2:00 PM PREVAILING TIME
Place:	YONKERS BUREAU OF PURCHASING ONE LARKIN CENTER, 3RD FLOOR YONKERS, N.Y. 10701

Located in the Yonkers Riverfront Library Building across from the Metro North train station.
 Bidders are reminded that bids received after 2:00 are late and will not be accepted - allow sufficient time to find parking and get through security.

Due to the COVID-19 Pandemic and in line with the directives issued by the Mayor of Yonkers regarding public safety, there is limited access to One Larkin Center. The building is open from 8:30 AM to 4:00 PM for receiving packages via courier services and in person. If delivering bids in person, individuals must wear face coverings and see the Public Safety Officer in the library atrium who will clock in the bid and then contact Purchasing to pick up the bid. Sealed Bids will continue to be opened and read at the specified date and time, however, there will not be a public opening of bids. Those interested in listening to the bid opening and the reading of bids can dial Conference Call number 1-701-802-5221 and enter Access Code 1354203 when prompted on the due date of the bid opening. The bid opening will start promptly at 2:00 pm. It is recommended that vendors are dialed in by 1:55 pm to hear the bid results. No questions will be answered while the bid opening is in progress.

5. Pre-Bid / Site Inspection:

Date:	Tue 11/16/2021	Time:	11:00 AM
Location:	Former Site of St. Denis School 121 McLean Avenue, Yonkers, NY 10705		

Meet at 121 McLean Avenue
Due to active demolition work at the site, you MUST stay outside the construction area.

6. Project Contacts

Kevin Austin, Sr. Program Manager Phone 773-490-4230 kaustin@savinengineers.com	Tom Collich, Purchasing Director City of Yonkers / YPS 914.377.6035 thomas.collich@YonkersNY.gov
---	---

All questions regarding the contents of this bid must be submitted in writing to **BOTH** Project Contacts listed above BY WEDNESDAY 12/1/21 4:00 PM Questions should be submitted by email. Answers to all inquiries will be given to all prospective vendors in the form of a formal addendum to the solicitation and shall be annexed to and become part of the ensuing contract BY FRIDAY 12/3/21 4:00 PM

Only written addenda issued by the Bureau of Purchasing shall be binding. No officer, employee, or agent of the City is authorized to clarify or amend the Solicitation Documents by any other method, and any such clarification or amendment, if given, is not binding on the City. Prospective Bidders are reminded that it is their responsibility to ensure that they receive all addenda.

The following additions, substitutions, or clarifications are extracted from the (5) Bid Addenda issued with this project during bidding. This insert is intended to summarize addendum information relevant to this specification section. See Bid Addenda issued by the City of Yonkers for complete contract document changes.

Bid Addendum No. 1:

On Page 4, Item 10, add the following indented item after "Statement of Bidder's Qualifications (AIA A305) including Exhibits A, B, C, D and E"

- "City of Yonkers Bidder's Affidavit"

On Page 11, add the following to become Item 31:

"31. CITY OF YONKERS BIDDER'S AFFIDAVIT

The bidder is required to include with its bid the "City of Yonkers Bidder's Affidavit" fully executed and notarized. This form is included in the Bid Documents."

INSTRUCTIONS TO BIDDERS

To be considered, Bids must be made in accordance with these Instructions to Bidders.

1. PROJECT DESCRIPTION

The Project consists of performing new construction of Community School 35 as shown on the Contract Drawings and described in the Specifications. The scope of the Work of this project generally consists of the construction of a new School Building, Community Building and appurtenant facilities at 121 McLean Avenue, Yonkers, NY (the former St Denis School, Rectory and Convent Site). Refer to Section 011000 "Description of Work" and Section 011010 "Multiple Contract Summary" for additional information on the scope of the Work.

2. TYPE OF CONTRACT

The Work of this Project will be let in four (4) separate contracts divided according to the work of the separate Prime Contractors for the following:

Contract No. 1 - General Construction Work
Contract No. 2 - Plumbing and Fire Protection Work
Contract No. 3 - HVAC Work
Contract No. 4 - Electrical Work

Responsibilities assigned to each separate Prime Contractor and the scope of the Work included in each contract is clearly identified in the Specifications.

3. TIME SCHEDULE

It is the intent of the Owner to award the Contracts for the Work on or about four (4) weeks after receipt of bids. Immediately upon receipt of Notice of Award of Contract from Owner, Contractors shall begin preparing required bonds, insurance certificates and other required submittals. Work may be performed at the site only upon receipt of written authorization (Notice to Proceed) from Owner and after the approval of the required submissions.

The Work shall be Substantially Complete on or before the date(s) indicated in the "Milestone Schedule" Section 011020. It is extremely important that the Owner assume its full use of the buildings and sites on the completion date(s) specified.

Liquidated damages will be assessed by the Owner for each calendar day beginning on the first day after the Contractor fails to achieve Substantial Completion within the Contract Time until the date that Substantial Completion is achieved.

4. QUALIFICATIONS OF BIDDERS

The Owner may make such investigation as it deems necessary to determine the responsibility of any bidder or to determine the ability of any bidder to perform the Work. The Owner reserves the right to disqualify any prospective bidder or to reject any bid.

Determination of Bidder Qualifications:

1. The Corporation, limited liability company, partnership, sole proprietorship or principals of the entity in whose name the bid is submitted has no less than the previous five (5) years performing or coordinating the Work which they are bidding on.
2. The firm and principal(s) have satisfactorily completed no less than five (5) projects of comparable size and type to this project within the past 3 years.
3. The bidder is capable of and intends and intends to perform the work with its own employees in accordance with the Bid Drawings and Contract Manual and Specifications.
4. The bidder will perform the work with sufficient personnel as required to comply with the schedule.
5. The bidder or principals of the bidder and each subcontractor must have a minimum of five (5) years of experience in the work and/or applicable trade.
6. Field Superintendent must have at least five (5) years as a working field superintendent and must speak English.
7. All bidders will be required to submit a listing of projects, including addresses, Owner's name, Architect, date work was performed and any other information which would serve to document its ability to perform the work of the character desired and in time required.

Authority to Do Business in New York:

1. Any corporation not incorporated under the Laws of New York State must furnish a copy of its Certificate of Authority from the New York State Secretary of State to do business in the State of New York, in accordance with Article 13 of the New York State Business Corporation Law.
2. Any limited liability company not formed under the Laws of New York State must furnish a copy of its Certificate of Authority from the New York State Secretary of State to do business in the State of New York, in accordance with Article 8 of the New York State Limited Liability Company Law.
3. Additional information is available at Department of State, 41 State Street, Albany, NY 12231 (518-473-2492).

Plumbing and Electrical Contractors: All Plumbing and Electrical Contractors engaged on this project must be licensed by Westchester County (914-995-2000). Licensing information can be obtained at:

<http://consumer.westchestergov.com/trades/plumbers-and-electricians>

5. DOCUMENTS

Bidders may obtain electronic copies of the Bid Documents after 2:00PM on Friday November 5, 2021 by downloading from the Empire State Purchasing Group website at <http://www.empirestatebidsystem.com/>

Bidders must register on this website to obtain the bid documents. There is no registration fee, and there is no cost to download the bid documents.

Please note the Empire State Purchasing Group website <http://www.empirestatebidsystem.com/> is the designated location and means for distributing and obtaining all bid package information. All bidders are urged to register to ensure receipt of all necessary information, including bid addenda

6. EXAMINATION

Bidders shall carefully examine the Bid Documents and the existing site to obtain first-hand knowledge of existing conditions and to verify conditions under which work will be performed. Failure to do so will not relieve a successful bidder of the obligation to furnish all material and labor necessary to carry out the provisions of the Contract Documents and to complete the contemplated work for the construction set forth in his bid. Submission of a Bid will be considered conclusive evidence that a bidder has visited the site and is conversant with local facilities and difficulties, the requirements of the Contract Documents, applicable laws and codes, the state of labor and material markets, and has made due allowance in his bid for all contingencies that may arise, whether or not stated.

7. QUESTIONS

Should a bidder find discrepancies in, or omissions from the drawings or any Contract Documents, or should he be in doubt, as to their meaning, or should he find provisions of any law or applicable code conflicting with provisions of the Contract Documents, he shall at once notify the Construction Manager in writing, who will endeavor to issue the necessary clarifications or revisions to prospective bidders by means of an Addendum. Addenda will be posted the Empire State Purchasing Group website <http://www.empirestatebidsystem.com/> Such Addendum, as part of the Contract Documents, shall be binding on all bidders. It shall be the duty of each bidder to make certain that he has received or provided himself with copies of all Addenda. Bids will be conclusively presumed to be based upon all Addenda issued up to the time of the opening of Bids, regardless of whether or not a copy of each Addendum is actually in the possession of the bidder.

Prospective bidders may request clarifications of the Bid Documents by simultaneously contacting both of the Project contacts, at the following e-mail addresses:

- the Construction Manager, Kevin Austin at Savin Engineers, PC, by e-mail at kaustin@savinengineers.com
- the City of Yonkers Purchasing Director, Tom Collich, by e-mail at thomas.collich@YonkersNY.gov

All questions must be submitted in writing via e-mail, no phone calls will be accepted. All correspondence must be addressed to subject line "Community School 35".

Inquiries received over the phone will not be answered. All information will be relayed to bidders by written addenda. Neither the Owner nor the Architect will be responsible for any

oral instruction or clarification to any persons whatsoever. Questions received less than seven (7) calendar days prior to the bid opening date cannot be answered.

If a bidder, prior to submitting a Bid, fails to give notification to the Architect of the existence of any such discrepancies, omissions, ambiguities, errors, or conflicts, he shall comply with the interpretations or directions given by the Architect in resolving same, without claiming extra costs

Addenda will be published on the Empire State Purchasing Group website <http://www.empirestatebidsystem.com/> and will automatically be sent to all registered bidders.

8. INTERPRETATION OF BID DOCUMENTS

If, in the interpretation of Bid Documents, requirements within the Drawings and Specifications conflict, or it appears that the Drawings and Specifications are not in agreement, the Contractor shall base his bid on (1) the greater quantity, where there is a discrepancy in quantity; and (2) the superior quality, where there is a discrepancy in quality.

9. PRE-BID MEETING

A pre-bid meeting will be held on Tuesday November 16, 2021 at 11:00 AM at the former site of St. Denis School located at 121 McLean Avenue, Yonkers, NY 10705. Attendance at the prebid meeting is not mandatory for submitting a bid but is strongly encouraged. Due to active demolition work at the site, access to the site will not be permitted.

10. PREPARATION OF BIDS

Each Bid must be completed in duplicate on the applicable Bid Form(s) provided herein. All blank spaces must be filled in with ink in both words and figures. Erasures or other changes in a proposal must be explained or noted over the signature of the bidder. The Bid shall be signed by person or persons legally authorized to bind Bidder to Contract.

The following shall be considered part of the bid and are required to be submitted with each Bid Form:

- Bid Breakdown Schedule of Values - pertinent to each contract
- Certificate of Compliance with the Iran Divestment Act
- Certificate of Compliance with the MacBride Principles
- Yonkers Joint Schools Construction Board Bid Package Diversification Documents
- City of Yonkers Vendor Background Questionnaire
- Statement of Contractor's Apprenticeship Program Compliance
- Bid Security
- Statement of Bidder's Qualifications (AIA A305) including Exhibits A, B, C, D and E

All blank spaces on all attachments to the Bid Form must be filled in with ink in both words and figures.

Any Bid submitted contrary to requirements above or specified, or containing omissions, conditions, or irregularities of any kind may be rejected by the Owner.

11. CERTIFICATE OF COMPLIANCE WITH THE IRAN DIVESTMENT ACT

In accordance with the requirements of General Municipal Law §103-g, the bidder is required to include with its bid either (1) the "Certification of Compliance with the Iran Divestment Act" or, in the case where the bidder is unable to make such certification, (2) the form titled "Declaration of Bidder's Inability to Provide Certification of Compliance with the Iran Divestment Act". This form is included in the Bid Documents.

12. CERTIFICATE OF COMPLIANCE WITH THE MACBRIDE PRINCIPLES

The bidder is required to include with its bid the "Certification of Compliance with the MacBride Principles. This form is included in the Bid Documents.

13. CITY OF YONKERS VENDOR BACKGROUND QUESTIONNAIRE

The bidder is required to include with its bid the "City of Yonkers Vendor Background Questionnaire" fully executed and notarized. This form is included in the Bid Documents.

14. STATEMENT OF CONTRACTOR'S APPRENTICESHIP PROGRAM COMPLIANCE

The bidder is required to include with its bid the "Statement of Contractor's Apprenticeship Program Compliance" fully executed and notarized. This form is included in the Bid Documents.

15. BID SECURITY

Each bid must be accompanied by a Bid Security made payable to Yonkers Joint Schools Construction Board in the amount of five percent (5%) of the Bid Sum (the sum of the Base Bid plus all Add Alternates). The Bid Security shall be either a certified bank check or a Bid Bond issued by a surety company licensed to conduct business in the State of New York on the form included herein (AIA Document A310). The Bid Bond must be issued by a surety which meets the requirements set forth in Article 11 of the General Conditions. The successful bidder's security will be retained until he has signed the Agreement and furnished required Performance and Payment Bonds. The Owner reserves the right to retain the security of the three lowest bidders for each contract until the successful bidder enters into the contract, or until 45 days after the bid opening, whichever is longer. All other bid security will be returned within 5 days after the bid opening. Attorneys-in-fact who sign bid bonds or contract bonds must file with each bond a certified and effectively dated copy of their power of attorney.

16. CONTRACTOR'S QUALIFICATION STATEMENT

Submit a properly executed Contractor's Qualification Statement on the form included herein (AIA Document A305 with Exhibits A, B, C, D and E) with the Contractor's bid. The Contractor's Qualification Statement must be signed and notarized. All items must be

answered and the data given must be clear and comprehensive. Failure to answer these questions in a complete and satisfactory manner may result in the rejection of the bid. Failure to submit a properly executed Contractor's Qualification Statement with the Bid may result in the rejection of the bid. Additional information may be submitted by bidder, if desired.

If, after evaluating the Contractor's Qualification Statement, the Owner has any doubt that a Bidder has the proper qualifications, it may require from that Bidder within 3 working days and prior to a Contract award, further written evidence of financial data, previous experience, personnel resumes, or other information. If after evaluating supplied data and investigating the evidence, the Owner has any reasonable doubt that a Bidder has the experience, available personnel, reliability, or availability of financial resources to complete the project in a timely manner and in full compliance with the requirements of the Contract, the Owner may reject the Bid and award to the next lowest qualified Bidder

17. PERFORMANCE AND LABOR AND MATERIAL BOND

The successful bidder shall provide a Performance Bond and Payment Bond made payable to Yonkers Joint Schools Construction Board, each in an amount at least equal to one hundred percent (100%) of the Contract Price as security for the faithful performance of his Contract and for payment of all persons performing labor and furnishing materials in connection with the project. The value of each bond shall be adjusted during the Project construction period to reflect changes in the Contract Sum. All Bonds must meet or exceed the requirements set forth in Article 11 of the General Conditions of the Contract for Construction. Provide such bonds simultaneously with the execution of the Contract. Bonding company and bond must be approved by the Owner. Only sureties licensed to do business in the State of New York may be used.

18. SUBMITTAL

Submit each Bid in an opaque, sealed envelope. Identify the envelope with: (1) project name, (2) name of bidder, (3) Contract name (e.g. Contract No. 1 - General Construction Work) and (4) proposal opening date. Submit Bids in accordance with the YJSCB Information for Bidders Cover Sheet and Advertisement for Bids and with these Instructions to Bidders. If forwarded by mail, the Bid must be enclosed in another envelope and forwarded to the Owner by certified mail or tracked delivery at the address indicated in the YJSCB Information for Bidders Cover Sheet and Advertisement for Bids. The bidder assumes the risk of any delay in the mail or in handling of the bid by the Owner. The bidder assumes full responsibility for having his bid deposited on time and to the location and person indicated in the YJSCB Information for Bidders Cover Sheet and Advertisement for Bids, regardless of the method of delivery.

19. MODIFICATION AND WITHDRAWAL

No oral, facsimile, or telephonic proposals or modifications of Bids will be considered. Bids may be modified at any time prior to bid opening by submitting to the Owner a written modification, enclosed in a sealed opaque envelope, signed by the bidder, or an officer thereof if the bidder is a corporation, clearly setting forth in what respects the Bid is to be

modified. Bids may be withdrawn on written or telegraphic request received from bidders prior to the time fixed for bid opening. Except as otherwise provided by law, negligence on the part of the bidder in preparing his Bid confers no right for the withdrawal of the Bid after it has been opened. No bidder may withdraw his Bid for forty-five (45) days after the opening thereof, except as otherwise provided by law.

20. REJECTION OF BIDS

The Owner reserves the right to reject any and all Bids. The Owner reserves the right to reject any Bid for reasons including, but not limited to, the following:

- a. The bidder fails to furnish any portion of the information required pursuant to the Instructions to Bidders.
- b. The bidder mis-states or conceals any material fact.
- c. The Bid does not strictly conform to law or to requirements of the Contract Documents.
- d. The Bid is conditional.
- e. The Bid is incomplete (by reason of, for example, failure to fill in an alternate price or failure to submit required documentation described herein).
- f. The Bidder is deemed unqualified to undertake the work.

The Owner reserves the right, however, to waive any informalities in the Bids received when such waiver is deemed to be in its interest.

21. OPENING AND AWARD

Bids will be opened as stated in the YJSCB Information for Bidders Cover Sheet and Advertisement for Bids. The Owner will award the Contracts, if at all, on or about four weeks after receipt of bids.

The Owner reserves the right to accept Alternates in any order or combination and to determine the low bidder on the basis of the sum of the Base Bid and Alternates accepted.

22. EXECUTION OF CONTRACT

After the Owner has ascertained the successful bidder, it shall send a Notice of Award of Contract to bidder to whom a Contract has been awarded.

The Contract used for this project shall be the Standard Form of Agreement Between Owner and Contractor, Construction Manager as Advisor Edition - AIA Document A132, 2019 Edition published by the American Institute of Architects as modified herein.

In case of failure or refusal of an accepted Bidder to enter into a Contract within ten (10) days after the issue date of the Notice of Award, or to provide the Performance and Payment Bonds simultaneously with the execution of such Contract, the bidder will be considered as having abandoned the Contract. In such event, the bidder shall be liable for and agrees to pay to the Owner, on demand, damages for such failure or refusal. Such damages shall be the difference between the price bid by him and the price for which such

contract shall subsequently be relet, plus the cost of such reletting, plus any other consequential expenses and damages.

The amount of such bidder's Bid Security shall be retained by the Owner and shall be applied toward payment of such damages. If any amount remains in excess of such damages, such remaining amount shall be returned to the bidder.

23. SUBCONTRACTORS

All Subcontractors must be acceptable to the Architect and/or Owner. When requested by the Architect and/or Owner, the Bidder shall submit the names of the Subcontractors proposed for use on the Project and all other information concerning his Subcontractors as requested by the Architect and/or Owner within the time frame stipulated. If the Architect and/or Owner disapproves any proposed Subcontractor the contractor shall submit the name of an alternate Subcontractor to whom the Architect and/or Owner has no objection in the same manner as the original submittal.

The Owner reserves the right to reject any bid if the names of the proposed Subcontractors are not submitted as required.

24. SALES AND COMPENSATING USE TAXES

The Owner is exempt from paying sales and compensating use taxes of the State of New York and of cities, counties, and other subdivisions of the State on all materials sold to it pursuant to the provisions of this Contract. These taxes are not to be included in bids. This exemption shall apply to supplies and materials which are incorporated in such project. This exemption does not, however, apply to equipment rentals, small tools, and supplies for equipment such as supplies of gasoline used in operating trucks. The term "materials" as used in this article shall include supplies incorporated in this project. A Tax Exemption Certificate will be furnished to the Contractor by the Owner upon request.

25. LAWS AND REGULATIONS

All applicable State Laws, municipal ordinances, and the rules, regulations and ordinances of all authorities having jurisdiction over construction of the project, including but not limited to Chapter 355 of the Laws of the State of New York 2016 (known as the Yonkers City School District Joint Schools Construction and Modernization Act) shall apply to the Contract throughout, and they will be deemed to be included in the Contract the same as though herein written out in full.

26. AFFIRMATIVE ACTION PROVISION

During the performance of this Contract, each Contractor agrees that he will not discriminate against any employee or applicant for employment because of race, color, religion, sex, national origin, age or disability. Such action shall include, but not be limited to the following: employment, upgrading, demotion or transfer; recruitment or recruitment advertising; layoffs or termination; rates of pay or other forms of compensation; and selection for training, including apprenticeship. Each Contractor agrees to include, or

require the inclusion of the above provision in any subcontract made pursuant to its contract with the Owner.

27. MINORITY AND WOMAN OWNED BUSINESS ENTERPRISES (MWBE) PARTICIPATION

The Contractor, in addition to any other nondiscrimination provision of the Contract and at no additional cost to the Owner, shall fully comply and cooperate with the Owner in the implementation of the Owner's Minority and Woman Owned Business Enterprises (MWBE) Participation Plan (YJSCB's Diversity Plan). These requirements include contracting opportunities for certified minority and women-owned business enterprises ("MWBEs"). Contractor's demonstration of "good faith efforts" shall be a part of these requirements. These provisions shall be deemed supplementary to, and not in lieu of the nondiscrimination provisions required by the Owner or other applicable federal, state or local laws.

The Owner has established an overall goal of 30% for Minority and Women-Owned Business Enterprises ("MWBE") participation, 20% for Minority Owned Business Enterprises ("MBE") participation and 10% for Women-Owned Business Enterprises ("WBE") participation (based on the current availability of qualified MBEs and WBEs).

For purposes of providing meaningful participation by MWBEs on the Contract and achieving the Contract Goals, Contractor should reference the directory of New York State Certified MBWEs found at the following internet address: <http://www.esd.ny.gov/mwbe.html>

Additionally, Contractor is encouraged to contact the Division of Minority and Woman Business Development (518) 292-5250; (212) 803-2414; or (716) 846-8200) to discuss additional methods of maximizing participation by MWBEs on the Contract.

Bidders are required to submit MWBE documentation with the bids as required by the YJSCB Bid Package Diversification Documents contained in Section 004130 of Division 00.

Contractors are required to submit MWBE documentation post-bid as required by the YJSCB Minority and Woman-Owned Business Enterprise and Workforce Utilization Forms contained in Section 007300 of Division 00.

28. EQUIVALENCY CLAUSE

Whenever a material, article, device, piece of equipment or type of construction is identified on the Drawings or in the Specifications by reference to manufacturers' or vendors' names, trade names, catalog numbers, or similar specific information, it is so identified for the purpose of establishing a standard of quality, and such identification shall not be construed as limiting competition. Any material, article, device, piece of equipment or type of construction of other manufacturers or vendors that will perform adequately the duties imposed by the general design will be considered equally acceptable provided the material, article, device, piece of equipment or type of construction so proposed is completely described in submittals to the Architect and is, in the opinion of the Architect, of equal substance, appearance, and function. If the contractor desires to use any kind, type, brand, or manufacturer or material other than those named in the specifications, they shall indicate

in writing, when requested, and prior to award of contract, what kind, type, brand, or manufacturer is included in the base bid for the specified item, following procedures specified in Section 016000. Refer to Division 01 General Requirements (Section 016000) and General Conditions of the Contract for Construction.

29. PAYMENT/ACCOUNTING AND EMPLOYMENT REQUIREMENTS

Contractor shall comply with the latest NYSDOL requirements, including all posting requirements, minimum wage requirements and all other requirements.

Prevailing Wage Rates: The New York State Department of Labor PRC number assigned to this project is PRC#2021011009 - New Community School 35. Current Wage Rate Schedules can be found here:

To access the PDF file of your schedule, click on the following link or copy and paste into your browser.

<https://apps.labor.ny.gov/wpp/publicViewProject.do?method=showIt&id=1521952>

NYSDOL Requirements for OSHA 10 Compliance: The Contractor shall certify that every worker employed for this project has completed an OSHA 10 safety training course prior to performing any work on the project. Valid proof of completion of the OSHA 10 training course includes copies of bona fide course completion card and training roster, attendance record, or other documentation from the certified trainer. Simply attesting that all employees have completed the course is not sufficient proof of completion.

30. POST BID PROCEDURES

- A. The responsibility of bidders and of their proposed subcontractors will be considered in making the award. The Owner through the Architect may make such investigation as the Owner deems necessary to determine the responsibility of any bidder or to determine the ability of any bidder to perform the Work.
- B. When requested by the Architect, bidders shall furnish all information and data required by the Owner, including financial data, within the time and in the form and manner required by the Owner. Upon notification from the Architect, the three apparent low bidders for each contract shall furnish within three (3) working days after the bid opening four (4) copies of the following information in writing:
 - 1. A signed and notarized bidder qualification statement;
 - 2. The names, addresses and phone numbers of the subcontractors and suppliers that the bidder proposes to use on the project;
 - 3. The bidder's proposed site safety plan;
 - 4. A bar chart schedule showing the bidders' proposed plan and schedule to complete the bidder's work in accordance with the milestones outlined in Section 011020;
 - 5. The insurance certificates required by the Bid Documents;
 - 6. A proposed schedule of values for the bidder's work;
 - 7. A proposed list of submittals and a proposed schedule for making them, all keyed to the bar chart.

8. A list of proposed substitutions.
 - C. After receipt of the above information, the Architect will designate a time and place for a meeting between the Owner, the Architect and the apparent low bidder. The apparent low bidder's principal, project manager and site superintendent will attend that meeting, at which time the parties will discuss the bidder's responsiveness, responsibility and qualifications.
 - D. The Owner reserves the right to disapprove the use of any proposed Subcontractor and in such event the bidder shall submit the name of another Subcontractor in a similar manner within the time specified by the Architect.
 - E. To the fullest extent allowed by law, the Owner reserves the right to reject any bid if the evidence required by the Owner is not submitted or fails to satisfy the Owner that the bidder is responsible, able and qualified to carry out the obligations of the Contract or to complete the Work as contemplated. The Owner will consider the information received under paragraphs A through D above in determining whether or not to accept a proposal.
 - F. Acceptance of a proposal will be a notice in writing signed by a duly authorized representative of the Owner.
 - G. Any bidder whose proposal is accepted will be required to sign the Contract within ten (10) days after receiving notice of acceptance.
 - H. In the event that the Owner should reject the proposal of a bidder as provided above or otherwise, at the Owner's option, the Owner may elect to meet with the next lowest bidder and to consider the information as provided in paragraphs A through D above. In the event that the proposal of the next lowest bidder is rejected as provided above or otherwise, at the Owner's option, the Owner may elect to meet with the third lowest bidder and repeat the above process. At all times the Owner retains the right to reject all bids.

END OF INSTRUCTIONS TO BIDDERS

INFORMATION AVAILABLE TO BIDDERS

1.1 GENERAL

- A. Site Information: Data in subsurface investigation reports included herein are provided to the Contractor for information only. Conditions are not intended as representations or warranties of accuracy or continuity between soil borings. The Owner will not be responsible for interpretations or conclusions drawn from this data by Contractor.
 - 1. Additional test borings and other exploratory operations may be performed by Contractor, at the Contractor's option and at the Contractor's sole expense; however, no change in the Contract Sum will be authorized for such additional exploration.

Geotechnical Report

Yonkers Public Schools St. Denis Community School

121 McLean Avenue
Yonkers, New York

February 5, 2021

Prepared for:

Kaeyer, Garment + Davidson Architects
285 Main Street
Mount Kisco, NY 10549

Prepared by:

SKYLANDS ENGINEERING, LLC
124 Milton Road
Sparta, NJ 07871

Geotechnical Report

Yonkers Public Schools St. Denis Community School

121 McLean Avenue
Yonkers, New York

February 5, 2021

Prepared for:

Kaeyer, Garment + Davidson Architects
285 Main Street
Mount Kisco, NY 10549

Prepared by:

SKYLANDS ENGINEERING, LLC
124 Milton Road
Sparta, NJ 07871
Certificate of Authorization No. 0013524

Eugene J. Schwarzrock, Professional Engineer
New York License No. 077007

Date

2-5-2021

Note: it is a violation of N.Y. Education Law, Section 7209 for any person to alter any item in this report in any way, unless they are acting under the direction of a Professional Engineer registered in New York. The altering engineer shall affix to this page their seal, the notation "altered by" followed by their signature and date of alteration, and a specific description of the alteration(s) made.



TABLE OF CONTENTS

INTRODUCTION 1

GEOLOGY 1

SUBSURFACE INVESTIGATION 2

SUBSURFACE CONDITIONS 2

DESIGN RECOMMENDATIONS 4

ACADEMIC BUILDING 4

COMMUNITY BUILDING 6

BREEZEWAY 7

RETAINING WALL 7

CONSTRUCTION RECOMMENDATIONS 8

APPENDIX

- Subsurface Investigation Plan
- Boring Logs
- Test Pit Logs
- Field Permeability Test Results

INTRODUCTION

This project consists of the design and construction of a new Yonkers Public Schools academic facility on the site of the previous St. Denis School, rectory and convent, within portions of the city block bounded by Radford Street, McLean Avenue, Lawrence Street, and Van Cortlandt Park Avenue (Block 6), and the northeast portion of the block bounded by Radford Street, Van Cortlandt Park Avenue, Lawrence Street and Western Ave. (Block 15), in the City of Yonkers, Westchester County, New York. A new Academic Building will be built in the southcentral/southeast portion of Block 6. This 4-sty, L-shaped building will replace the existing 2.5-sty to 4-sty St. Denis School building, will extend ± 200 ft. east-west along Lawrence Street and 120 ft. along McLean Avenue (north-south), and will cover $\pm 17,000$ SF. A basement is planned beneath the southeast quadrant of the building. A standalone ± 150 LF x ± 3 ft. tall retaining wall will replace existing retaining walls along the north side of the Academic Building site which provide grade separation for the higher school property.

A new gymnasium/auditorium Community Building will be built in the northwest quadrant of Block 6. This 2-sty, rectangular building will replace the existing 2.5-sty St. Denis rectory building, and cover an area ± 90 ft. x ± 100 ft., or $\pm 9,000$ SF. A basement is planned beneath the western half of the building.

A new Breezeway will connect the above two (2) buildings at the ground floor level.

At Block 15, a playground is proposed in the 40 ft. x 80 ft. northeast corner, and an underground stormwater management facility with parking lot will be constructed in the ± 50 ft. x ± 115 ft. adjoining area to the south. An existing Convent/chapel will be demolished prior to construction.

The site of the proposed school currently contains the old church buildings, grass and asphalt parking lots. Existing grades are generally uniform, with grades varying from El. ± 82 in the southeast of Block 6 to El. 81 across the majority of the proposed Academic Building footprint, to El. 78.5 in the northwest corner of Block 6 at the proposed Community Building. The grades at Block 15 are also generally uniform, with the southern end of the site at El. ± 80 and grades dropping to El. ± 77.5 at the northeast corner. The new Academic Building will be constructed with the ground floor at El. 81.2, and the new Community Building will be constructed at El 78.8. The Breezeway will be ramped between these two (2) elevations.

This report presents the findings of a subsurface investigation prepared and conducted by others specifically for this project, as well as recommendations for foundation design and construction of the proposed new structures.

GEOLOGY

Based on our review of topographic maps and published geologic data for this area of Yonkers, including the *Surficial Geologic Map of New York - Lower Hudson Sheet*, 1989, by Caldwell, Connally, et. al., this site is expected to be underlain by glacial till consisting of a mixture of grain sizes ranging from clay and silt, to sand, cobbles and boulders. Underlying bedrock is expected to be relatively shallow and consist of Fordham gneiss, based on the *(Bedrock) Geologic Map of New York - Lower Hudson Sheet*, 1970, by Rickard, Isachsen, and Fisher.

SUBSURFACE INVESTIGATION

Soiltesting, Inc. of Oxford, CT performed 32 borings, four (4) test pits, and three (3) field permeability tests between December 4, 2020 and January 8, 2021 to identify the subsurface conditions present beneath the project sites. Borings B-1 through B-29 (minus B-1, B-7 and B-11) were performed for consideration of the new buildings, while borings C-1 through C-3 and D-1 through D-3 were performed in support of subsurface drainage design. Test Pits were numbered A-1 through A-4 and were performed alongside the existing school building, rectory, convent, and St. Denis Catholic Church, respectively.

In the structural borings, soil samples were attempted generally continuously from the ground surface to a depth of 12 ft., then at 5 ft. intervals to the completion of each boring, which generally was 27 ft. Borings B-8 and B-26 were continued to depths of 62 ft. and 67 ft. respectively. All borings except B-26, were drilled using a nominal 4-¼ in. hollow stem auger to advance and maintain the hole. Boring B-26 was drilled using 3 in. diameter casing with a roller-bit and water/drilling mud. Sampling was performed using a 2 in. O.D. split spoon sampler driven by a 140 lb. safety hammer with a 30 in. drop and the number of blows for each 6 in. increment was recorded, in accordance with procedures outlined in ASTM D1586, Standard Test Method for Standard Penetration Test (SPT) and Split-Barrel Sampling of Soils. Soil samples were classified by an experienced geologist from Soiltesting, Inc., in general agreement with D.M. Burmister's "Suggested Test Methods for Identification of Soils" (ASTM, 1958).

In the stormwater design borings, the "C" borings were drilled using a 4 in. diameter casing with a roller-bit and water to clean out each hole and no soil sampling was not performed. Auger cuttings were used to classify the soils. The "D" borings were drilled using a 2-½ in. hollow stem auger and sampling was performed at 5 ft. intervals beginning at or just below the ground surface.

Groundwater was recorded at each boring when it was first encountered since most of the borings were performed without the introduction of water.

Three (3) in situ permeability tests were performed at borings C-1 through C-3 inside a 4 in. I.D. steel casing installed ±8 ft. deep. C-1 was located in the open space immediately north of the proposed Academic Building, while C-2 and C-3 were located on Block 15. After installing the casing to the test depth, it was cleaned out of soil, and water added to the top of casing to allow the ground to soak for 13 days at C-1 and 1 day at C-2 and C-3. On January 5, 2021 a measurement was made of the drop in water level over the presoak period, then down-the-hole permeability tests were run by successively adding water to the casing and measuring the water drop vs. time, in general accordance with ASTM D6391 - Standard Test Method for Field Measurement of Hydraulic Conductivity Using Borehole Infiltration. This was continued until uniform readings were obtained.

A Boring Location Plan, boring logs, test pit logs are presented in the Appendix. The boring logs were amended by Skylands Engineering to include the approximate elevations and groundwater elevations at each boring.

SUBSURFACE CONDITIONS

The subsurface conditions encountered beneath the site are generally consistent with the published geologic literature. In the area of the proposed Academic Building, granular fill consisting of fine,

medium to fine, and coarse to fine sand, with varying minor amounts of coarse to fine and fine gravel, asphalt, brick, and concrete was encountered in most borings to depths ranging from ± 4 ft. to ± 8 ft. Beneath this fill, native, medium dense brown, mostly fine sand with minor amounts of fine gravel are present to a depth of ± 12 ft. Standard penetration test (SPT) N-values ranged from 6 blows per foot (bpf) to 36 bpf, with $N_{ave}=\pm 18$. Beneath a depth of ± 12 ft. and continuing to an estimated depth of ± 23 ft., a very loose to loose, mostly fine sand layer, approx. 5 ft. to 10 ft. thick, is present. N-values in this layer ranged from 3 bpf to 9 bpf, with $N_{ave}=\pm 5$ bpf. Below ± 23 ft. most borings encountered loose to barely-medium dense fine sand, with just three (3) of fifteen (15) borings encountering medium dense to dense sands. Most N-values in this layer ranged from 3 bpf to 12 bpf, with $N_{ave}=\pm 8$ bpf. The one (1) deeper boring here, B-26, encountered dense and very dense, medium to fine sand below a depth of 45 ft. and to the completion of the boring at 62 ft., with N-values ≥ 44 bpf and $N_{ave}=52$ bpf.

Soils beneath the proposed Community Building were very similar in composition and relative densities (SPT N-values). The surficial, granular fill was somewhat thinner, being encountered only to a depth of 4 ft. in half of the borings. Beneath this fill, a similar pattern of approx. 8 ft. to 10 ft. of medium dense sand, underlain by 5 ft. to 10+ ft. of loose sand, underlain by barely-medium dense sand was encountered to the bottom of the borings. Average N-values here were slightly higher than those recorded beneath the Academic Building. SPT N-values ranged from 3 bpf to 9 bpf with $N_{ave}=\pm 6$ bpf in the upper fill, ranged from 10 bpf to 31 bpf with $N_{ave}=\pm 17$ bpf in the medium dense sand layer between the depths of ± 4 ft. and ± 13 ft., ranged from 4 bpf to 10 bpf with $N_{ave}=\pm 7$ bpf in the lower loose sand layer from ± 13 ft. to ± 22 ft. to ± 27 ft., and ranged from 10 bpf to 29 bpf with $N_{ave}=\pm 15$ bpf in the lower medium dense sand layer.

At the Block 15 site, borings D-2 and D-3 encountered similar conditions as described above. Loose, granular fill was encountered in boring D-3 to a depth of 4 ft., then a ± 5 ft. thick layer of medium dense sand was present to a depth of ± 9 ft., and finally loose sands were present to the bottom of both borings at 27 ft. SPT N-values averaged 5 bpf in the upper 4 ft., $N_{ave}=\pm 20$ bpf at the 5 ft. samples, and $N_{ave}=\pm 7$ below 10 ft. and continuing to a depth of 27 ft.

Bedrock was not encountered in any boring and no estimation of its depth can be inferred from the boring logs.

Groundwater was encountered across all three (3) construction sites at depths of 10 ft. to 12 ft. (El. ± 71.7 to El. ± 67.3). Within Block 6, the groundwater surface appears to be tilted slightly downward to the northwest, while in Block 15 the groundwater surface also appears to dip to the north.

The permeability tests performed in proposed courtyard of the Academic Building site and at the Block 15 site were each located at a depth of 8 ft. Initial readings following the overnight (and longer) soak period indicated no water was present in the casing at the start of the permeability tests. During testing, the water level inside the casing dropped 52 in. to 300 in. per hour, for calculated permeability rates of 4 in./hr. to 21 in./hr. (see Field Permeability Test Results in the Appendix).

Complete records of the findings of the subsurface investigation are shown on the borings, test pit, and permeability test logs in the Appendix.

DESIGN RECOMMENDATIONS

Based on our review of the findings of this subsurface investigation program, it is recommended that conventional spread footings are suitable for support of the proposed Academic Building, Community Building, and retaining wall immediately north of the Academic Building. The recommended footing/frost depth for Yonkers is 40 in. below final exterior grade therefore perimeter footings should be constructed at or below this depth to prevent frost heave damage. The following sections present our recommendations for each of the separate areas of work on this project.

ACADEMIC BUILDING

The proposed finish floor of the Academic Building is El. 81.2. Assuming an 8 ft. ceiling height and 2 ft. beam and slab depths in the partial basement, we estimate the partial basement finish floor will be at El. ± 71.2 , or ± 6 in. below the highest recorded groundwater elevation. The soils present beneath the partial basement are expected to consist of loose fine sands. In order to provide suitable support and limit post construction settlements to acceptable tolerances, it is recommended that 24 in. of soil be over excavated from the bottom of footings, the subgrade be thoroughly compacted, then recycled concrete aggregate (RCA), crushed stone, or structural fill be placed and compacted in the excavations back up to the bottom of footing elevation. The excavations should also be widened 12 in. in all directions. Following this remediation, an allowable bearing capacity of 2 tons per square foot (tsf) is recommended for design. A coefficient of base sliding of 0.45 is recommended based on the in situ soils and anticipated structural fill properties. Minimum footing widths of 30 in. for wall footings and 36 in. for column footings are recommended to limit settlements.

Beyond the limits of the partial basement, it is assumed footings will be founded at minimum depth for frost protection, or at approximately El. 76.5. At this elevation, the footings will be underlain mostly by native, medium dense sands, which are suitable for support, but also loose fills. The fill soils are expected to be encountered west of the basement, and at the north-center corner of the new building. The native soils present at the bottom of footing excavations should be compacted thoroughly and until no further settlement is visible. Where fill is present at the bottom of footing excavation, this material should be removed completely, the bottom of the excavation thoroughly compacted, then compacted structural fill placed back up to the bottom of footing elevation. It is expected that between 2 ft. and 4 ft. of fill will need to be removed from below these footings. Similar to above, such over excavations should also be widened 12 in. in all directions. Following this remediation, an allowable bearing capacity of 2 tsf and a coefficient of base sliding of 0.45 are recommended for design. Minimum footing widths of 30 in. for wall footings and 36 in. for column footings are recommended to limit settlements.

The following in situ soil properties are recommended for design of retaining wall portions of this building:

Moist unit weight of retained soil,	$\gamma_t = 120$ pcf
Angle of internal friction,	$\phi = 32^\circ$
Lateral earth pressure coefficients:	
Active,	$K_a = 0.31$
Passive,	$K_p = 3.25$
At-rest,	$K_o = 0.47$ (basement walls)
Coeff. of friction (sliding),	$\tan \delta = 0.45$ (CIP concrete on compacted subgrade)



Following the above recommendations, it is estimated that maximum post construction foundation settlement will be less than 1 in., with no more than ½ in. differential settlement between adjacent columns. These values are within generally accepted tolerance limits for this type of structure/use. Settlement will be elastic (instantaneous), with no long-term consolidation settlement occurring.

The new floor slabs may be constructed as slabs-on-grade following removal of the surficial asphalt and topsoil, removal of any deleterious material that may be present in the fill, proof rolling and compaction of the subgrade, placement of any required fill, then placement of capillary break material. The subgrade should be compacted using a 10 T vibratory roller away from building walls and a double-drum, walk-behind vibratory roller (ex. Rammax trench compactor) adjacent to the walls in order to provide uniform support beneath the slab. A minimum of two (2) passes should be made with the compactor on all areas of subgrade, and until no further settlement is visible. A modulus of subgrade reaction equal to 150 pci is recommended for design of these slabs.

The need for waterproofing is not anticipated in areas outside the partial basement since groundwater is expected to be ±10 ft. below the first floor elevation. Beneath the partial basement however, since the basement slab will be partially below the groundwater elevation, it is recommended to either waterproof the underside of the slab and walls, and/or install underslab drainage pipe in a bed of crushed stone or recycled concrete aggregate (RCA) and connect this piping to sump pumps in order to prevent water seepage into the basement. The elevator pit should be designed as a bathtub, assuming a pit depth of ±5 ft. We recommend using a groundwater elevation of El. 72.5 for waterproofing and buoyancy design.

In accordance with the provisions of Section 1613.3.2 of the New York 2015 Building Code, and ASCE 7-10/16 Chapter 20, a seismic site class of D, stiff soil, is recommended for design of the Academic Building, based on the average conditions encountered to a depth of 62 ft., then assumed similar conditions continuing to a depth of 100 ft. Note this is a somewhat conservative assumption since bedrock may be shallower than 100 ft. Based on the project location, in conjunction with the above site class, the following seismic parameters follow from the Code and ASCE 7-16:

$S_s = 0.296$	$S_1 = 0.061$
$F_a = 1.563$	$F_v = 2.4$
$S_{MS} = 0.463$	$S_{M1} = 0.147$
$S_{DS} = 0.309$	$S_{D1} = 0.098$

Seismic Design Category Based on Short Period Response Accelerations = B*

Seismic Design Category Based on 1-sec Period Response Accelerations = B*

* based on assumed Risk Category III

There is no evidence of past slope instability and none is expected under static or seismic loading.

Based on a screening of N-values vs. depth, we believe the fine sands present at a depth of ±13 ft. to 28 ft. may have potential to liquefy, although their effect may be limited due to their discontinuity and limited depth. A rigorous analysis is recommended to determine the actual factors of safety against liquefaction of these soils.



COMMUNITY BUILDING

The proposed finish floor of the Community Building is El. 78.8. Assuming an 8 ft. ceiling height and 3.5 ft. beam and slab depths in the partial basement, we estimate the partial basement finish floor will be at El. ± 67.3 , or 1 ft. to 2 ft. below the groundwater elevations recorded here. Similar to the findings and recommendations for the Academic Building, the soils present beneath this partial basement are also expected to consist of loose fine sands. Therefore, in order to provide suitable support and limit post construction settlements to acceptable tolerances, it is recommended that 24 in. of soil be over excavated from the bottom of footings, the subgrade be thoroughly compacted, then RCA, crushed stone, or structural fill be placed and compacted in the excavations back up to the bottom of footing elevation. The excavations should also be widened 12 in. in all directions. Similar to above, following this remediation, an allowable bearing capacity of 2 tsf and a coefficient of base sliding of 0.45 is recommended for design. Minimum footing widths of 30 in. for wall footings and 36 in. for column footings are also recommended here to limit settlements.

Beyond the limits of the partial basement, it is assumed footings will be founded at minimum depth for frost protection, or at approximately El. 75.5. At this elevation, the footings are expected to be underlain mostly by medium dense, native sands, which are suitable for support. Limited quantities of loose granular fill are also expected in the northeast corner of the building, near where boring B-8 was performed. The native soils present at the bottom of footing excavations should be compacted thoroughly and until no further settlement is visible. Where fill is present at the bottom of footing excavation, this material should be removed completely, the bottom of the excavation thoroughly compacted, then compacted structural fill placed back up to the bottom of footing elevation. It is expected that between 6 in. and 12 in. of fill will need to be removed from below some footings. Based on the limited depth of over excavation required, over excavations here should be widened 6 in. in all directions. Following this remediation, an allowable bearing capacity of 2 tsf and a coefficient of base sliding of 0.45 are recommended for design. Minimum footing widths of 30 in. for wall footings and 36 in. for column footings are recommended to limit settlements.

The in situ soil properties recommended above for the Academic Building are also recommended for design purposes of the Community Building. They are repeated here for clarity:

Moist unit weight of retained soil,	$\gamma_t = 120$ pcf
Angle of internal friction,	$\phi = 32^\circ$
Lateral earth pressure coefficients:	
Active,	$K_a = 0.31$
Passive,	$K_p = 3.25$
At-rest,	$K_o = 0.47$ (basement walls)
Coeff. of friction (sliding),	$\tan \delta = 0.45$ (CIP concrete on compacted subgrade)

Following the above recommendations, maximum post construction foundation settlements are expected to be less than $\frac{3}{4}$ in., with no more than $\frac{1}{2}$ in. differential settlement between adjacent columns. These values are within generally accepted tolerance limits for this type of structure/use. Settlement will be elastic (instantaneous), with no long-term consolidation settlement occurring.

The new floor slabs may be constructed as slabs-on-grade following removal of the topsoil and excess soil, removal of any deleterious material that may be present in the fill, proof rolling and compaction of the subgrade, then placement of capillary break material. The subgrade should be compacted using a

10 T vibratory roller away from building walls and a double-drum, walk-behind vibratory roller (ex. Rammax trench compactor) adjacent to the walls in order to provide uniform support beneath the slab. A minimum of two (2) passes should be made with the compactor on all areas of subgrade, and until no further settlement is visible. A modulus of subgrade reaction equal to 150 pci is recommended for design of these slabs.

The need for waterproofing is not anticipated in areas outside the partial basement since groundwater is expected to be ± 10 ft. below the first floor elevation. Beneath the partial basement however, since the basement slab will be below the groundwater elevation by 1 ft. to 2 ft., it is recommended to either raise the building to be above groundwater, or waterproof the underside of the slab and walls and construct the basement as a bathtub. The elevator pit should be designed as a bathtub, assuming a pit depth of ± 5 ft. We recommend a design groundwater elevation of El. 72 for waterproofing and buoyancy design.

Similar to above, based on the average conditions encountered to a depth of 67 ft., then assumed similar conditions continuing to a depth of 100 ft., a seismic site class of D, stiff soil, is recommended for design of the Community Building. The seismic parameters and derived seismic design categories shown above also apply to this building, based on an assumed Risk Category III.

Similar to above, there is no evidence of past slope instability and none is expected under static or seismic loading.

A screening of N-values vs. depth indicates the fine sands present at depths of ± 13 ft. to ± 23 ft. may have potential to liquefy, although their effect may be limited due to their discontinuity and limited depth. A rigorous analysis is recommended to determine the actual factors of safety against liquefaction of these soils.

BREEZEWAY

The Breezeway will connect the Academic Building to the Community Building and will be fully enclosed. Spread footings founded at frost depth are the recommended foundation choice since the underlying soils are expected to consist mostly of medium dense, native sands, which are suitable for support. Limited quantities of loose granular fill may be encountered in the southern portion, near where boring B-14 was performed. The native soils present at the bottom of footing excavations should be compacted thoroughly and until no further settlement is visible. Where fill is present at the bottom of footing excavation, this material should be removed completely, the bottom of the excavation thoroughly compacted, then compacted structural fill placed back up to the bottom of footing elevation. It is expected that between 12 in. and 24 in. of fill may need to be removed from below some footings. Based on the light loads, over excavations here should be widened 6 in. in all directions. Following this remediation, an allowable bearing capacity of 2 tsf and a coefficient of base sliding of 0.45 are recommended for design. Minimum footing widths of 20 in. for wall footings and 30 in. for column footings are recommended to limit settlements.

RETAINING WALL

In order to support the school property from the lower ground to the north, a ± 150 LF x 3 ft. tall (exposed height) retaining wall is proposed for replacement of existing walls of similar length and height. Given the low height of this wall, it is recommended to construct this wall as a cast-in-place

concrete wall with the footing founded at frost depth. Based on existing grades, the footing is expected to be set at El. ± 74 . Beneath this elevation the underlying soils are expected to consist mostly of loose to medium dense granular fills, especially in the center and east portions of the wall, and medium dense native sands in the western portion. Any fill material encountered should be removed to a maximum depth of 12 in., then the bottom of the excavation compacted thoroughly, and compacted structural fill placed back up to the bottom of footing elevation. Following this an allowable bearing capacity of 2 tsf is recommended for design. The following in situ soil properties are also recommended for design of this retaining wall:

Moist unit weight of retained soil,	$\gamma_t = 115$ pcf
Angle of internal friction,	$\phi = 32^\circ$
Lateral earth pressure coefficients:	
Active,	$K_a = 0.31$
Passive,	$K_p = 3.25$
At-rest,	$K_o = 0.47$
Coeff. of friction (sliding),	$\tan \delta = 0.45$ (CIP concrete on compacted granular soils)
	$\tan \delta = 0.30$ (Precast masonry on compacted granular soils)

CONSTRUCTION RECOMMENDATIONS

Footings should not be constructed on frozen or wet subgrade materials. All frozen or saturated subgrade soil should be removed and replaced with compacted structural fill, or clean crushed stone, as required.

All loosened soil present at the bottoms of footing excavations should be compacted using a jumping jack, or vibratory trench compactor such as a double-drum, pad foot roller (ex. Rammax). Such compaction should continue until all visible settlement is complete.

Care shall be taken during compaction and construction of new footings adjacent to existing structures. A pre-construction condition assessment of all adjacent structures is highly recommended so that new movements may be detected, and corrective actions may be taken, as early as possible. If any cracks exist prior to the start of construction, crack gages should be installed and monitored through the time of foundation construction.

Organic soils were not encountered in the borings other than the surficial topsoil; however, if organic soils are encountered they should be removed completely from beneath the limits of work and replaced with compacted structural fill. Organic soils should not be used as site or structural backfill, but should be removed offsite.

Cobbles and boulders were not encountered in the borings and are therefore not expected to be encountered within the depths of excavation. Any cobbles or boulders encountered during construction should be removed so that no part protrudes into the bottom or sides of foundation or utility excavations.

Dewatering will be required during basement construction since groundwater was measured at or slightly higher than the planned basement elevations. Given the size and expected duration of each excavation, a construction dewatering consultant or specialty contractor should be engaged by the design team to assess the possible volumes of water that will need to be removed. Since cohesive soils



were not encountered in any of the borings to a depth of 60+ ft., some minor lowering of the groundwater table may be tolerable by the surrounding buildings. However, large-scale groundwater lowering will be difficult to achieve given the relatively flat groundwater surface and the anticipated moderately-high permeability rates of the in situ sands. It may be more economical to work smaller sections of basement or footings at a time, and to use RCA or crushed stone, in lieu of structural fill, so that footing excavations remain open for the shortest amount of time.

Structural fill material should consist of predominately well-graded, coarse to fine sand and/or gravel with a maximum 10% non-plastic fines (material passing a No. 200 sieve) and be free of organics and other deleterious materials. Soil with up to 20% fines may be used above 3 ft. higher than the groundwater level. Aggregate size should be limited to no bigger than 3 in. in the largest dimension. Based on the findings of this subsurface investigation, it is estimated that >½ of the in situ materials may be suitable for reuse as structural fill. Representative samples of any structural fill materials, whether on-site or imported, should be tested for gradation and moisture-density relationship prior to use to confirm its suitability.

Structural fill should be placed in maximum 12 in. loose lifts and compacted to 95% of its maximum dry density at optimum moisture content as determined by the Modified Proctor Density Test (ASTM D 1557). These operations should be performed under full-time geotechnical inspection and testing by either the Sand Cone Method (ASTM D 1556), Nuclear Density Gauge (ASTM D 2922 and D 3012), or other moisture/density test methods. These density tests should be performed by an experienced geotechnical inspector at sufficient frequency and spacing to ensure proper compaction, with the following criteria suggested as guidelines:

Location	Frequency of Testing
Structural fill beneath foundations, adjacent to structures & beneath slabs-on-grade	1 test every 2,500 SF min. 1 test per lift
Utility trenches	1 test every 50-100 LF per lift min. 3 tests per day
General site fill (beyond building limits)	1 test every 5,000 SF per lift min. 1 test per lift

For excavations that extend deeper than 5 ft., sheeting, shoring, sloping, or benching of the excavation sidewalls is required per OSHA standards. Considering the relatively open space and lack of shallow bedrock at this site, all the above-mentioned means may be suitable for use at this project. Based upon the material characteristics and estimated strength of the soils encountered during the subsurface exploration, the soil present on site may be assumed to be Type C and should be sloped at a 1.5H:1V (34°) per OSHA requirements. For the design of temporary sheeting or shoring, the soil properties listed above for retaining wall design are recommended. All sheeting, shoring and bracing shall be designed by a professional engineer licensed in the State of New York.

It is recommended that all foundation construction and subgrade preparation procedures be inspected by a qualified geotechnical engineer experienced with these types of construction. Full time inspection

is recommended during placement of structural fill to ensure adequate testing is performed, and moisture contents are maintained at suitable levels.

APPENDIX

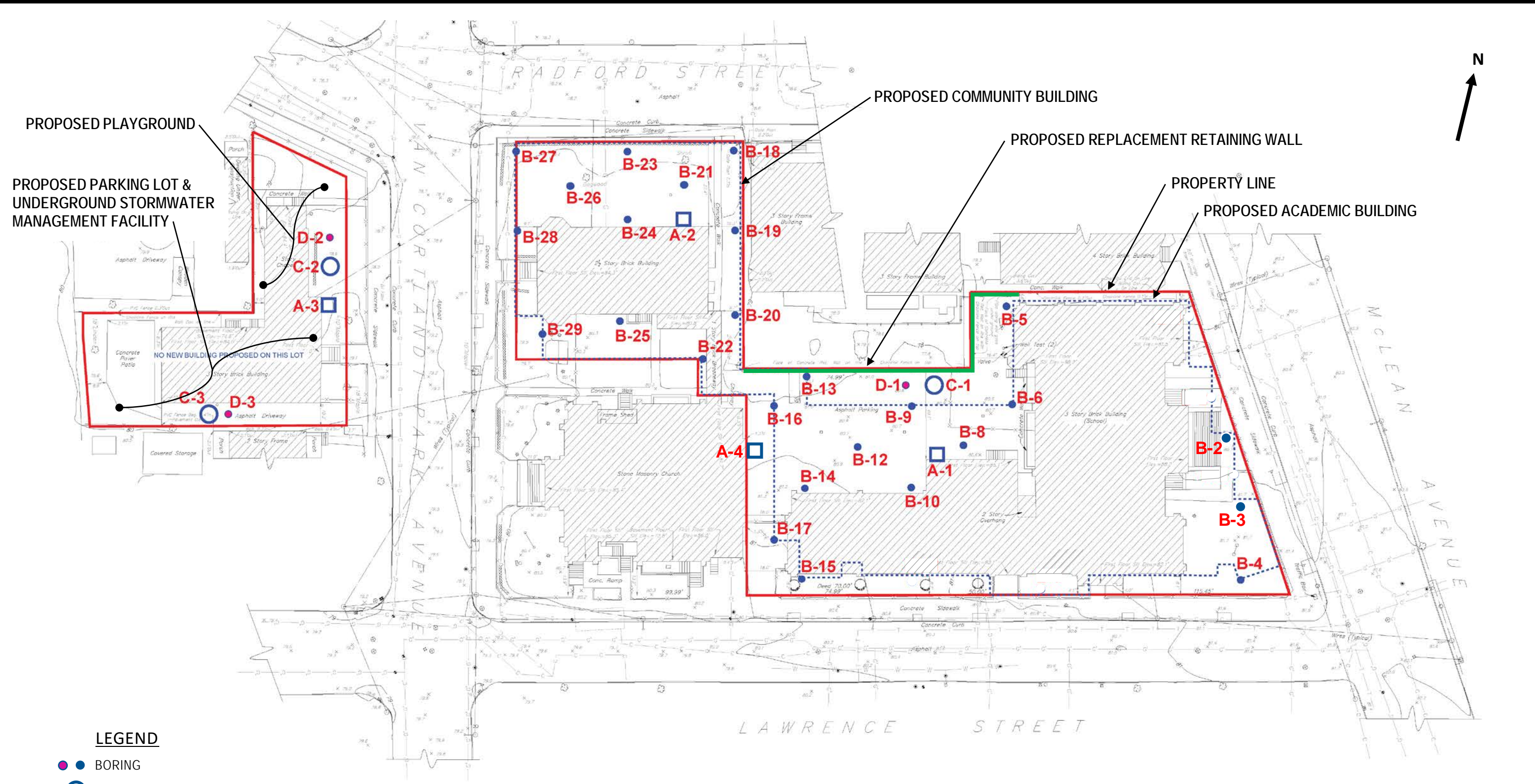

PROPOSED PLAYGROUND

PROPOSED PARKING LOT & UNDERGROUND STORMWATER MANAGEMENT FACILITY

PROPOSED COMMUNITY BUILDING

PROPOSED REPLACEMENT RETAINING WALL

PROPERTY LINE

PROPOSED ACADEMIC BUILDING

NO NEW BUILDING PROPOSED ON THIS LOT

LEGEND

- BORING
- FIELD PERMEABILITY TEST
- TEST PIT

SCALE
N.T.S.

NOTES:

1. BASE PLAN EXCERPTED FROM "LAYOUT FOR BORINGS FOR NEW SCHOOL" PLAN, PROVIDED BY KG&D.
2. UPDATED BORING LOCATIONS PROVIDED BY SOILTESTING, INC.

EUGENE J. SCHWARZROCK
PROFESSIONAL ENGINEER
NEW YORK LICENSE NO. 077007-1

DATE

SUBSURFACE INVESTIGATION PLAN

ST. DENIS COMMUNITY SCHOOL
121 McLEAN AVENUE
YONKERS, NEW YORK

SKYLANDS ENGINEERING, LLC

124 MILTON ROAD
SPARTA, NJ 07871
CERTIFICATE OF AUTHORIZATION 0013524

DATE: 2-5-2021

Boring Logs

SOILTESTING, INC. 90 DONOVAN RD. OXFORD, CT 06478 CT (203) 262-9328 NY (914) 946-4850	CLIENT: KG&D Architects & Engineers	SHEET <u>1</u> OF <u>1</u>
	PROJECT NO. G211-1671-20	HOLE NO. B-2
	PROJECT NAME Former St Denis Parochial School	BORING LOCATIONS per Plan
FOREMAN - DRILLER MK/ao	LOCATION Van Cortlandt Park Ave & Lawrence St Yonkers, NY	
INSPECTOR	CASING TYPE HSA	SAMPLER SS*
GROUND WATER OBSERVATIONS AT <u>10</u> FT AFTER <u>0</u> HOURS	SIZE I.D. 4 1/4"	1 3/8"
AT <u> </u> FT AFTER <u> </u> HOURS	HAMMER WT. 140#	BIT
	HAMMER FALL 30"	GROUND WATER ELEV. EI. ±70.7

DEPTH	CASING BLOWS PER FOOT	SAMPLE					BLOWS PER 6 IN ON SAMPLER (FORCE ON TUBE)				CORE TIME PER FT (MIN)	DENSITY OR CONSIST	STRATA CHANGE DEPTH	FIELD IDENTIFICATION OF SOIL REMARKS INCL. COLOR, LOSS OF WASH WATER, SEAMS IN ROCK, ETC.
		NO	Type	PEN	REC	DEPTH @ BOT	0-6	6-12	12-18	MOIST				
5	1	ss	24"	14"	2'0"	3	2			moist	2'0"	6" concrete, 6" brick/asphalt		
	2	ss	24"	12"	4'0"	1	2			v loose		Brn F SAND, sm silt (possible fill)		
						5	7			moist		Brn F SAND		
	3	ss	24"	18"	6'0"	7	12			compact		Brn F SAND		
						12	13			moist				
	4	ss	24"	18"	8'0"	24	15			compact		SAME		
						12	12			moist				
	5	ss	24"	17"	10'0"	6	7			compact		SAME		
						9	9			compact				
	6	ss	24"	20"	12'0"	10	4			wet		SAME		
					5	4			loose					
15	7	ss	24"	20"	17'0"	5	2			wet	27'0"	SAME		
					1	2			v loose					
20	8	ss	24"	20"	22'0"	8	7			wet	27'0"	SAME		
					7	8			compact					
25	9	ss	24"	24"	27'0"	5	5			wet	27'0"	SAME		
					7	7			compact					
30											27'0"	E.O.B 27'0"		
35											27'0"			
40											27'0"			

NOTE: Subsoil conditions revealed by this investigation represent conditions at specific locations and may not represent conditions at other locations or times.

GROUND SURFACE TO _____ FT. USED _____ CASING THEN _____ CASING TO _____ FT.	HOLE NO. B-2
A = AUGER UP = UNDISTURBED PISTON T = THINWALL V = VANE TEST	
WOR = WEIGHT OF RODS WOH = WEIGHT OF HAMMER & RODS	C = COARSE
SS = SPLIT TUBE SAMPLER H.S.A. = HOLLOW STEM AUGER	M = MEDIUM
PROPORTIONS USED: TRACE = 0 - 10% LITTLE = 10 - 20% SOME = 20 - 35% AND = 35 - 50%	F = FINE

SOILTESTING, INC. 90 DONOVAN RD. OXFORD, CT 06478 CT (203) 262-9328 NY (914) 946-4850	CLIENT: KG&D Architects & Engineers	SHEET <u>1</u> OF <u>1</u> HOLE NO. B-3
	PROJECT NO. G211-1671-20	
	PROJECT NAME Former St Denis Parochial School	BORING LOCATIONS per Plan
FOREMAN - DRILLER MK/ao	LOCATION Van Cortlandt Park Ave & Lawrence St Yonkers, NY	
INSPECTOR	CASING TYPE HSA SAMPLER SS* CORE BAR	OFFSET
GROUND WATER OBSERVATIONS AT <u>10</u> FT AFTER <u>0</u> HOURS	SIZE I.D. 4 1/4" 1 3/8"	DATE START 1/8/21
AT <u> </u> FT AFTER <u> </u> HOURS	HAMMER WT. 140# BIT	DATE FINISH 1/8/21
	HAMMER FALL 30"	SURFACE ELEV. EI. ±81.7
		GROUND WATER ELEV. EI. ±71.7

DEPTH	CASING BLOWS PER FOOT	SAMPLE					BLOWS PER 6 IN ON SAMPLER (FORCE ON TUBE)			CORE TIME PER FT (MIN)	DENSITY OR CONSIST	STRATA CHANGE DEPTH	FIELD IDENTIFICATION OF SOIL REMARKS INCL. COLOR, LOSS OF WASH WATER, SEAMS IN ROCK, ETC.
		NO	Type	PEN	REC	DEPTH @ BOT	0 - 6	6 - 12	12 - 18				
5	1	ss	24"	12"	2'0"	1	9			moist	4'0"	6" Topsoil	
	2	ss	24"	12"	4'0"	1	2			compact		Brn F SAND, tr gravel, brick (fill)	
						3	4			loose		Brn F SAND, sm silt (fill)	
	3	ss	24"	18"	6'0"	8	4			moist		Brn F SAND	
	4	ss	24"	20"	8'0"	10	11			compact		SAME	
10					15	12				moist		SAME	
	5	ss	24"	18"	10'0"	6	7			compact		SAME	
					7	8				compact		SAME	
	6	ss	24"	18"	12'0"	8	8			wet		SAME	
15					8	7				compact			
	7	ss	24"	20"	17'0"	4	3			wet		SAME	
20						2	2			loose			
	8	ss	24"	18"	22'0"	7	7			wet		SAME	
25						6	9			compact			
30	9	ss	24"	20"	27'0"	6	5			wet	27'0"	SAME	
						6	7			compact			
40												E.O.B 27'0"	

NOTE: Subsoil conditions revealed by this investigation represent conditions at specific locations and may not represent conditions at other locations or times.

GROUND SURFACE TO _____ FT. USED _____ CASING THEN _____ CASING TO _____ FT.	HOLE NO. B-3
A = AUGER UP = UNDISTURBED PISTON T = THINWALL V = VANE TEST	
WOR = WEIGHT OF RODS WOH = WEIGHT OF HAMMER & RODS	C = COARSE
SS = SPLIT TUBE SAMPLER H.S.A. = HOLLOW STEM AUGER	M = MEDIUM
PROPORTIONS USED: TRACE = 0 - 10% LITTLE = 10 - 20% SOME = 20 - 35% AND = 35 - 50%	F = FINE

SOILTESTING, INC. 90 DONOVAN RD. OXFORD, CT 06478 CT (203) 262-9328 NY (914) 946-4850	CLIENT: KG&D Architects & Engineers	SHEET <u>1</u> OF <u>1</u> HOLE NO. B-4
	PROJECT NO. G211-1671-20	
	PROJECT NAME Former St Denis Parochial School	BORING LOCATIONS per Plan
FOREMAN - DRILLER MK/ao	LOCATION Van Cortlandt Park Ave & Lawrence St Yonkers, NY	
INSPECTOR	CASING TYPE HSA SAMPLER SS* CORE BAR	OFFSET
GROUND WATER OBSERVATIONS AT <u>10</u> FT AFTER <u>0</u> HOURS	SIZE I.D. 4 1/4" 1 3/8"	DATE START 1/8/21
AT <u> </u> FT AFTER <u> </u> HOURS	HAMMER WT. 140# BIT	DATE FINISH 1/8/21
	HAMMER FALL 30"	SURFACE ELEV. EI. ±81.5
		GROUND WATER ELEV. EI. ±71.5

DEPTH	CASING BLOWS PER FOOT	SAMPLE					BLOWS PER 6 IN ON SAMPLER (FORCE ON TUBE)				CORE TIME PER FT (MIN)	DENSITY OR CONSIST	STRATA CHANGE DEPTH	FIELD IDENTIFICATION OF SOIL REMARKS INCL. COLOR, LOSS OF WASH WATER, SEAMS IN ROCK, ETC.
		NO	Type	PEN	REC	DEPTH @ BOT	0-6	6-12	12-18	MOIST				
5	1	ss	24"	10"	2'0"	1	2			moist	5'0"	6" Topsoil concrete, brick Brn F SAND, sm silt (possible fill)		
	2	ss	24"	16"	4'0"	1	1			v loose				
						2	2			moist				
	3	ss	24"	18"	6'0"	2	3			v loose				
						1	2			moist				
10	4	ss	24"	18"	8'0"	13	13			compact		Brn F SAND LtBrn F SAND		
						16	16			moist				
						14	12			compact				
	5	ss	24"	20"	10'0"	6	8			moist				
						6	6			compact				
15	6	ss	24"	24"	12'0"	7	9			wet		SAME		
										compact				
	7	ss	24"	24"	17'0"	4	3			wet				
						4	5			loose				
20	8	ss	24"	24"	22'0"	3	6			wet		SAME		
						5	5			compact				
25	9	ss	24"	24"	27'0"	6	6			wet	27'0"	SAME		
						5	7			compact				
30												E.O.B 27'0"		
35														
40													* SAFETY HAMMER CATHEAD & ROPE	

NOTE: Subsoil conditions revealed by this investigation represent conditions at specific locations and may not represent conditions at other locations or times.

GROUND SURFACE TO _____ FT. USED _____ CASING THEN _____ CASING TO _____ FT.	HOLE NO. B-4
A = AUGER UP = UNDISTURBED PISTON T = THINWALL V = VANE TEST	
WOR = WEIGHT OF RODS WOH = WEIGHT OF HAMMER & RODS	C = COARSE
SS = SPLIT TUBE SAMPLER H.S.A. = HOLLOW STEM AUGER	M = MEDIUM
PROPORTIONS USED: TRACE = 0 - 10% LITTLE = 10 - 20% SOME = 20 - 35% AND = 35 - 50%	F = FINE

SOILTESTING, INC. 90 DONOVAN RD. OXFORD, CT 06478 CT (203) 262-9328 NY (914) 946-4850	CLIENT: KG&D Architects & Engineers	SHEET <u>1</u> OF <u>1</u>
	PROJECT NO. G211-1671-20	HOLE NO. B-5
	PROJECT NAME Former St Denis Parochial School	BORING LOCATIONS per Plan
FOREMAN - DRILLER MK/jk	LOCATION Van Cortlandt Park Ave & Lawrence St Yonkers, NY	
INSPECTOR	CASING TYPE HSA	SAMPLER SS*
GROUND WATER OBSERVATIONS AT <u>11</u> ' FT AFTER <u>0</u> HOURS	SIZE I.D. 4 1/4"	CORE BAR 1 3/8"
AT <u> </u> ' FT AFTER <u> </u> HOURS	HAMMER WT. 140#	BIT BIT
	HAMMER FALL 30"	GROUND WATER ELEV. EI. ±69.9

DEPTH	CASING BLOWS PER FOOT	SAMPLE				DEPTH @ BOT	BLOWS PER 6 IN ON SAMPLER (FORCE ON TUBE)				CORE TIME PER FT (MIN)	DENSITY OR CONSIST	STRATA CHANGE DEPTH	FIELD IDENTIFICATION OF SOIL REMARKS INCL. COLOR, LOSS OF WASH WATER, SEAMS IN ROCK, ETC.
		NO	Type	PEN	REC.		0	6	6	12				
5	1	ss	24"	10"	2'0"	6	7					moist compact	8'0"	2" Asphalt; Brn FMC SAND, sm FC gravel
	2	ss	24"	5"	4'0"	3	4					dry loose		brick, concrete
	3	ss	24"	6"	6'0"	3	2					dry loose		Brn FMC SAND, lit FC gravel, brick, concrete frags
	4	ss	24"	6"	8'0"	3	2					dry v loose		SAME (fill)
	5	ss	24"	14"	10'0"	3	3					moist loose		
10	6	ss	24"	18"	12'0"	4	5					wet loose		Brn F SAND
						5	7					loose		Brn F SAND
15	7	ss	24"	20"	17'0"	3	2					wet v loose		Brn F SAND
						2	2							
20	8	ss	24"	22"	22'0"	3	2					wet loose		Brn F SAND
						5	3							
25	9	ss	24"	20"	27'0"	3	4					wet loose		GreyBrn F SAND
						4	5						27'0"	
30														E.O.B 27'0"
35														
40														* SAFETY HAMMER CATHEAD & ROPE

NOTE: Subsoil conditions revealed by this investigation represent conditions at specific locations and may not represent conditions at other locations or times.

GROUND SURFACE TO _____ FT. USED _____ CASING THEN _____ CASING TO _____ FT.	HOLE NO. B-5
A = AUGER UP = UNDISTURBED PISTON T = THINWALL V = VANE TEST	
WOR = WEIGHT OF RODS WOH = WEIGHT OF HAMMER & RODS	C = COARSE
SS = SPLIT TUBE SAMPLER H.S.A. = HOLLOW STEM AUGER	M = MEDIUM
PROPORTIONS USED: TRACE = 0 - 10% LITTLE = 10 - 20% SOME = 20 - 35% AND = 35 - 50%	F = FINE

SOILTESTING, INC. 90 DONOVAN RD. OXFORD, CT 06478 CT (203) 262-9328 NY (914) 946-4850	CLIENT: KG&D Architects & Engineers	SHEET <u>1</u> OF <u>1</u>
	PROJECT NO. G211-1671-20	HOLE NO. B-6
	PROJECT NAME Former St Denis Parochial School	BORING LOCATIONS per Plan
FOREMAN - DRILLER MK/jk	LOCATION Van Cortlandt Park Ave & Lawrence St Yonkers, NY	
INSPECTOR	CASING TYPE HSA	SAMPLER SS*
GROUND WATER OBSERVATIONS AT <u>10</u> FT AFTER <u>0</u> HOURS	SIZE I.D. 4 1/4"	1 3/8"
AT <u> </u> FT AFTER <u> </u> HOURS	HAMMER WT. 140#	BIT
	HAMMER FALL 30"	
		OFFSET
		DATE START 12/4/20
		DATE FINISH 12/4/20
		SURFACE ELEV. EI. ±80.7
		GROUND WATER ELEV. EI. ±70.7

DEPTH	CASING BLOWS PER FOOT	SAMPLE					BLOWS PER 6 IN ON SAMPLER (FORCE ON TUBE)		CORE TIME PER FT (MIN)	DENSITY OR CONSIST	STRATA CHANGE DEPTH	FIELD IDENTIFICATION OF SOIL REMARKS INCL. COLOR, LOSS OF WASH WATER, SEAMS IN ROCK, ETC.	
		NO	Type	PEN	REC	DEPTH @ BOT	0 - 6	6 - 12					12 - 18
5		1	ss	24"	10"	2'0"	7	3		dry	3'6"	2" Asphalt; OrgnBrn F SAND, tr FC gravel, tr silt	
						2	2		loose			Brn F SAND & SILT, tr FC gravel (possible fill)	
		2	ss	24"	16"	4'0"	2	3		moist			
							4	8		loose			
		3	ss	24"	12"	6'0"	7	9		moist			Brn FMC SAND
10						11	14		compact	27'0"	Brn FMC SAND, sm FC gravel		
		4	ss	24"	18"	8'0"	11	14			dry		OrgnBrn F SAND, tr F gravel
							18	19			dense		
		5	ss	24"	20"	10'0"	6	8			dry		
							8	6			compact		Brn F SAND
15						5	4		wet	27'0"	SAME		
									loose				
		7	ss	24"	18"	17'0"	2	2			wet		
							2	2			v loose		
20										27'0"	SAME		
		8	ss	24"	20"	22'0"	3	4			wet		
							3	5			loose		
25										27'0"	SAME		
		9	ss	24"	14"	27'0"	3	4			wet		
							4	5			loose		
30										27'0"	SAME		
35										27'0"	SAME		
40										27'0"	SAME		

NOTE: Subsoil conditions revealed by this investigation represent conditions at specific locations and may not represent conditions at other locations or times.

GROUND SURFACE TO _____ FT. USED _____ CASING THEN _____ CASING TO _____ FT.	HOLE NO. B-6
A = AUGER UP = UNDISTURBED PISTON T = THINWALL V = VANE TEST	
WOR = WEIGHT OF RODS WOH = WEIGHT OF HAMMER & RODS	C = COARSE
SS = SPLIT TUBE SAMPLER H.S.A. = HOLLOW STEM AUGER	M = MEDIUM
PROPORTIONS USED: TRACE = 0 - 10% LITTLE = 10 - 20% SOME = 20 - 35% AND = 35 - 50%	F = FINE

SOILTESTING, INC. 90 DONOVAN RD. OXFORD, CT 06478 CT (203) 262-9328 NY (914) 946-4850	CLIENT: <u>KG&D Architects & Engineers</u>		SHEET <u>1</u> OF <u>1</u> HOLE NO. <u>B-7</u>	
	PROJECT NO. <u>G211-1671-20</u>			
	PROJECT NAME <u>Former St Denis Parochial School</u>		BORING LOCATIONS per Plan	
FOREMAN - DRILLER	LOCATION <u>Van Cortlandt Park Ave & Lawrence St Yonkers, NY</u>			
INSPECTOR	TYPE	CASING <u>HSA</u>	SAMPLER <u>SS*</u>	CORE BAR
GROUND WATER OBSERVATIONS AT <u> </u> FT AFTER <u>0</u> HOURS AT <u> </u> FT AFTER <u> </u> HOURS		SIZE I.D. <u>4 1/4"</u>	<u>1 3/8"</u>	BIT
		HAMMER WT. <u>140#</u>	BIT	
		HAMMER FALL <u>30"</u>		
		OFFSET		DATE START
				DATE FINISH
				SURFACE ELEV.
				GROUND WATER ELEV.

DEPTH	CASING BLOWS PER FOOT	SAMPLE				DEPTH @ BOT	BLOWS PER 6 IN ON SAMPLER (FORCE ON TUBE)				CORE TIME PER FT (MIN)	DENSITY OR CONSIST	STRATA CHANGE DEPTH	FIELD IDENTIFICATION OF SOIL REMARKS INCL. COLOR, LOSS OF WASH WATER, SEAMS IN ROCK, ETC.
		NO	Type	PEN	REC		0	6	12	18				
5														THIS LOCATION OMITTED FROM SCOPE OF WORK
40														

NOTE: Subsoil conditions revealed by this investigation represent conditions at specific locations and may not represent conditions at other locations or times.

GROUND SURFACE TO _____ FT. USED _____ CASING THEN _____ CASING TO _____ FT. HOLE NO. B-7

A = AUGER UP = UNDISTURBED PISTON T = THINWALL V = VANE TEST
 WOR = WEIGHT OF RODS WOH = WEIGHT OF HAMMER & RODS C = COARSE
 SS = SPLIT TUBE SAMPLER H.S.A. = HOLLOW STEM AUGER M = MEDIUM
 PROPORTIONS USED: TRACE = 0 - 10% LITTLE = 10 - 20% SOME = 20 - 35% AND = 35 - 50% F = FINE

SOILTESTING, INC. 90 DONOVAN RD. OXFORD, CT 06478 CT (203) 262-9328 NY (914) 946-4850	CLIENT: <u>KG&D Architects & Engineers</u>	SHEET <u>1</u> OF <u>2</u>
	PROJECT NO. <u>G211-1671-20</u>	HOLE NO. <u>B-8</u>
FOREMAN - DRILLER JK/eq	PROJECT NAME Former St Denis Parochial School	BORING LOCATIONS per Plan
INSPECTOR	LOCATION Van Cortlandt Park Ave & Lawrence St Yonkers, NY	
GROUND WATER OBSERVATIONS AT <u>10'</u> FT AFTER <u>0</u> HOURS AT <u> </u> FT AFTER <u> </u> HOURS	CASING TYPE HSA SAMPLER SS* CORE BAR SIZE I.D. 4 1/4" 1 3/8" HAMMER WT. 140# BIT HAMMER FALL 30"	OFFSET DATE START 12/21/20 DATE FINISH 12/23/20 SURFACE ELEV. EI. +80.7 GROUND WATER ELEV. EI. +70.7

DEPTH	CASING BLOWS PER FOOT	SAMPLE					BLOWS PER 6 IN ON SAMPLER (FORCE ON TUBE)			CORE TIME PER FT (MIN)	DENSITY OR CONSIST	STRATA CHANGE DEPTH	FIELD IDENTIFICATION OF SOIL REMARKS INCL. COLOR, LOSS OF WASH WATER, SEAMS IN ROCK, ETC.
		NO	Type	PEN	REC	DEPTH @ BOT	0-6	6-12	12-18				
5	1	ss	24"	14"	2'0"	6	3			moist loose	4'0"	BrnOrng FM SAND, sm silt, tr asphalt (fill)	
	2	ss	24"	4"	4'0"	4	4			moist loose		LtBrn FM SAND, sm silt, tr asphalt (fill)	
	3	ss	24"	16"	6'0"	7	12			moist compact		LtBrnGrey F SAND, lit M sand	
	4	ss	24"	12"	8'0"	15	15			moist dense		LtBrn F SAND, lit M sand	
	5	ss	24"	22"	10'0"	18	16			moist compact		LtBrnGrey FM SAND, lit C sand	
10	6	ss	24"	14"	12'0"	5	4			wet loose		LtBrnGrey FM SAND, lit C sand	
						3	3						
	7	ss	24"	20"	17'0"	2	3			wet loose		GreyLtBrn F SAND, lit MC sand	
20						2	2						
	8	ss	24"	24"	22'0"	1	2			wet v loose		LtBrn F SAND, sm M sand	
						2	2						
25													
	9	ss	24"	23"	27'0"	6	11			wet compact		LtBrnGrey FM SAND, sm M sand	
						13	18						
30													
	10	ss	24"	24"	32'0"	6	13			wet compact		LtBrn F SAND, lit MC sand	
						15	17						
35													
	11	ss	24"	20"	37'0"	10	14			wet dense		LtBrn F SAND, sm M sand, tr C sand	
						17	22						
40												* SAFETY HAMMER CATHEAD & ROPE	

NOTE: Subsoil conditions revealed by this investigation represent conditions at specific locations and may not represent conditions at other locations or times.

GROUND SURFACE TO _____ FT. USED _____ CASING THEN _____ CASING TO _____ FT. **HOLE NO. B-8**

A = AUGER UP = UNDISTURBED PISTON T = THINWALL V = VANE TEST
 WOR = WEIGHT OF RODS WOH = WEIGHT OF HAMMER & RODS C = COARSE
 SS = SPLIT TUBE SAMPLER H.S.A. = HOLLOW STEM AUGER M = MEDIUM
 PROPORTIONS USED: TRACE = 0 - 10% LITTLE = 10 - 20% SOME = 20 - 35% AND = 35 - 50% F = FINE

SOILTESTING, INC. 90 DONOVAN RD. OXFORD, CT 06478 CT (203) 262-9328 NY (914) 946-4850	CLIENT: KG&D Architects & Engineers	SHEET <u>2</u> OF <u>2</u>
	PROJECT NO. G211-1671-20	HOLE NO. B-8
FOREMAN - DRILLER JK/eq	PROJECT NAME Former St Denis Parochial School	BORING LOCATIONS per Plan
INSPECTOR	LOCATION Van Cortlandt Park Ave & Lawrence St Yonkers, NY	
GROUND WATER OBSERVATIONS AT <u>10'</u> FT AFTER <u>0</u> HOURS AT <u> </u> FT AFTER <u> </u> HOURS	CASING TYPE HSA SAMPLER SIZE I.D. SS* 4 1/4" CORE BAR WEIGHT 140# BIT CORE BAR FALL 30"	OFFSET DATE START 12/21/20 DATE FINISH 12/23/20 SURFACE ELEV. EI. ±80.7 GROUND WATER ELEV. EI. ±70.7

DEPTH	CASING BLOWS PER FOOT	SAMPLE					BLOWS PER 6 IN ON SAMPLER (FORCE ON TUBE)			CORE TIME PER FT (MIN)	DENSITY OR CONSIST	STRATA CHANGE DEPTH	FIELD IDENTIFICATION OF SOIL REMARKS INCL. COLOR, LOSS OF WASH WATER, SEAMS IN ROCK, ETC.
		NO	Type	PEN	REC.	DEPTH @ BOT	0-6	6-12	12-18				
45		13	ss	24"	20"	42'0"	11	12			wet compact		LtBrn F SAND, sm M sand
							15	22					
50		14	ss	24"	23"	47'0"	16	20			wet dense		LtBrn F SAND, lit M sand
							24	28					
55		15	ss	24"	24"	52'0"	20	24			wet dense		LtBrn F SAND, sm M sand
							25	30					
60		16	ss	24"	24"	57'0"	22	26			wet v dense		LtBrn F SAND, lit M sand
							30	32					
65		17	ss	24"	23"	62'0"	26	27			wet v dense	62'0"	LtBrn F SAND, lit M sand
							31	35					
70													
75													
80													

NOTE: Subsoil conditions revealed by this investigation represent conditions at specific locations and may not represent conditions at other locations or times.

GROUND SURFACE TO _____ FT. USED _____ CASING THEN _____ CASING TO _____ FT.	HOLE NO. B-8
A = AUGER UP = UNDISTURBED PISTON T = THINWALL V = VANE TEST WOR = WEIGHT OF RODS WOH = WEIGHT OF HAMMER & RODS C = COARSE SS = SPLIT TUBE SAMPLER H.S.A. = HOLLOW STEM AUGER M = MEDIUM PROPORTIONS USED: TRACE = 0 - 10% LITTLE = 10 - 20% SOME = 20 - 35% AND = 35 - 50% F = FINE	

SOILTESTING, INC. 90 DONOVAN RD. OXFORD, CT 06478 CT (203) 262-9328 NY (914) 946-4850	CLIENT: KG&D Architects & Engineers	SHEET <u>1</u> OF <u>1</u>
	PROJECT NO. G211-1671-20	HOLE NO. B-9
	PROJECT NAME Former St Denis Parochial School	BORING LOCATIONS per Plan
FOREMAN - DRILLER JK/eq	LOCATION Van Cortlandt Park Ave & Lawrence St Yonkers, NY	
INSPECTOR	CASING SAMPLER CORE BAR	OFFSET
GROUND WATER OBSERVATIONS AT <u>10</u> FT AFTER <u>0</u> HOURS	TYPE HSA SS*	DATE START 12/21/20
AT <u> </u> FT AFTER <u> </u> HOURS	SIZE I.D. 4 1/4" 1 3/8"	DATE FINISH 12/21/20
	HAMMER WT. 140# BIT	SURFACE ELEV. EI. ±80.8
	HAMMER FALL 30"	GROUND WATER ELEV. EI. ±70.8

DEPTH	CASING BLOWS PER FOOT	SAMPLE					BLOWS PER 6 IN ON SAMPLER (FORCE ON TUBE)			CORE TIME PER FT (MIN)	DENSITY OR CONSIST	STRATA CHANGE DEPTH ELEV	FIELD IDENTIFICATION OF SOIL REMARKS INCL. COLOR, LOSS OF WASH WATER, SEAMS IN ROCK, ETC.
		NO	Type	PEN	REC	DEPTH @ BOT	0 - 6	6 - 12	12 - 18				
5	1	ss	24"	20"	20"	12	6			moist loose	6'0"	DkBrn FM SAND & SILT	
	2	ss	24"	6"	4'0"	4	3			dry/moist		LtBrn FM SAND, lit asphalt, lit silt	
						1	2			v loose			
	3	ss	24"	5"	6'0"	6	7			dry		LtBrn FM SAND, sm asphalt (fill)	
						9	14			compact			
10	4	ss	24"	14"	8'0"	16	18			moist	27'0"	LtBrn F SAND, lit M sand	
					18	22			dense				
	5	ss	24"	17"	10'0"	6	8			moist		GreyLtBrn F SAND, sm M sand, tr silt	
						9	11			compact			
	6	ss	24"	16"	12'0"	5	3			wet		SAME	
15						2	2			loose			
	7	ss	24"	12"	17'0"	1	2			wet	Grey F SAND		
						2	3			v loose			
20													
	8	ss	24"	16"	22'0"	4	6			wet	GreyBrn FM SAND		
						7	9			compact			
25													
	9	ss	24"	10"	27'0"	1	1			wet	Grey F SAND		
						2	2			v loose			
30													
35													
40													

NOTE: Subsoil conditions revealed by this investigation represent conditions at specific locations and may not represent conditions at other locations or times.

GROUND SURFACE TO _____ FT. USED _____ CASING THEN _____ CASING TO _____ FT. HOLE NO. **B-9**

A = AUGER UP = UNDISTURBED PISTON T = THINWALL V = VANE TEST
 WOR = WEIGHT OF RODS WOH = WEIGHT OF HAMMER & RODS C = COARSE
 SS = SPLIT TUBE SAMPLER H.S.A. = HOLLOW STEM AUGER M = MEDIUM
 PROPORTIONS USED: TRACE = 0 - 10% LITTLE = 10 - 20% SOME = 20 - 35% AND = 35 - 50% F = FINE

* SAFETY HAMMER CATHEAD & ROPE

SOILTESTING, INC. 90 DONOVAN RD. OXFORD, CT 06478 CT (203) 262-9328 NY (914) 946-4850	CLIENT: KG&D Architects & Engineers	SHEET <u>1</u> OF <u>1</u>
	PROJECT NO. G211-1671-20	HOLE NO. B-10
	PROJECT NAME Former St Denis Parochial School	BORING LOCATIONS per Plan
FOREMAN - DRILLER MK/jk	LOCATION Van Cortlandt Park Ave & Lawrence St Yonkers, NY	
INSPECTOR	CASING TYPE HSA	SAMPLER SS*
GROUND WATER OBSERVATIONS AT <u>10</u> FT AFTER <u>0</u> HOURS	SIZE I.D. 4 1/4"	1 3/8"
AT <u> </u> FT AFTER <u> </u> HOURS	HAMMER WT. 140#	BIT
	HAMMER FALL 30"	GROUND WATER ELEV. EI. ±70.9

DEPTH	CASING BLOWS PER FOOT	SAMPLE					BLOWS PER 6 IN ON SAMPLER (FORCE ON TUBE)				CORE TIME PER FT (MIN)	DENSITY OR CONSIST	STRATA CHANGE DEPTH	FIELD IDENTIFICATION OF SOIL REMARKS INCL. COLOR, LOSS OF WASH WATER, SEAMS IN ROCK, ETC.
		NO	Type	PEN	REC	DEPTH @ BOT	0-6	6-12	12-18	MOIST				
5	1	ss	24"	10"	2'0"	8	7				dry	8'0"	2" Asphalt; Brn FMC SAND, sm FC gravel, brick (fill)	
	2	ss	24"	8"	4'0"	6	3				compact dry		Brn F SAND, kit FC gravel, tr silt	
	3	ss	24"	14"	6'0"	5	4				loose dry		Brn FMC SAND, lit FC gravel, tr silt, asphalt (fill)	
	4	ss	24"	4"	8'0"	6	6				compact dry		SAME	
10	5	ss	24"	18"	10'0"	2	3				loose dry	8'0"	Brn F SAND, lit FC gravel	
	6	ss	24"	20"	12'0"	9	8				compact wet		Brn F SAND	
						6	4				compact			
15	7	ss	24"	20"	17'0"	3	4				wet loose	27'0"	GreyBrn F SAND	
						4	5							
20	8	ss	24"	22"	22'0"	5	4				wet loose	27'0"	Grey F SAND	
						4	6							
25	9	ss	24"	20"	27'0"	4	4				wet loose	27'0"	SAME	
						5	6							
30													E.O.B 27'0"	
35														
40														

NOTE: Subsoil conditions revealed by this investigation represent conditions at specific locations and may not represent conditions at other locations or times.

GROUND SURFACE TO _____ FT.	USED _____ CASING	THEN _____ CASING TO _____ FT.	HOLE NO. B-10
A = AUGER	UP = UNDISTURBED PISTON	T = THINWALL	V = VANE TEST
WOR = WEIGHT OF RODS	WOH = WEIGHT OF HAMMER & RODS	C = COARSE	M = MEDIUM
SS = SPLIT TUBE SAMPLER	H.S.A. = HOLLOW STEM AUGER	F = FINE	
PROPORTIONS USED: TRACE = 0 - 10% LITTLE = 10 - 20% SOME = 20 - 35% AND = 35 - 50%			

SOILTESTING, INC. 90 DONOVAN RD. OXFORD, CT 06478 CT (203) 262-9328 NY (914) 946-4850	CLIENT: KG&D Architects & Engineers	SHEET <u>1</u> OF <u>1</u>
	PROJECT NO. G211-1671-20	HOLE NO. B-12
	PROJECT NAME Former St Denis Parochial School	BORING LOCATIONS per Plan
FOREMAN - DRILLER JK/eq	LOCATION Van Cortlandt Park Ave & Lawrence St Yonkers, NY	
INSPECTOR	CASING TYPE HSA	SAMPLER SS*
GROUND WATER OBSERVATIONS AT <u>12</u> FT AFTER <u>0</u> HOURS	SIZE I.D. 4 1/4"	CORE BAR BIT
AT <u> </u> FT AFTER <u> </u> HOURS	HAMMER WT. 140#	OFFSET
	HAMMER FALL 30"	DATE START 12/21/20
		DATE FINISH 12/21/20
		SURFACE ELEV. EI. ±80.7
		GROUND WATER ELEV. EI. ±68.7

DEPTH	CASING BLOWS PER FOOT	SAMPLE				DEPTH @ BOT	BLOWS PER 6 IN ON SAMPLER (FORCE ON TUBE)			CORE TIME PER FT (MIN)	DENSITY OR CONSIST	STRATA CHANGE DEPTH	FIELD IDENTIFICATION OF SOIL REMARKS INCL. COLOR, LOSS OF WASH WATER, SEAMS IN ROCK, ETC.
		NO	Type	PEN	REC.		0	6	12				
5	1	ss	24"	6"	2'0"	12	10			dry		Brn FM SAND, lit asphalt, tr silt, tr F gravel	
	2	ss	24"	7"	4'0"	8	6			compact dry		Brn FMC SAND, lit asphalt, tr F gravel	
	3	ss	24"	8"	6'0"	5	3			compact dry		SAME	
	4	ss	24"	7"	8'0"	14	5			compact dry	8'0"	Brn FM SAND, lit F gravel, tr silt, tr brick (fill)	
	5					12	18			compact dry			
10	5	ss	24"	5"	10'0"	12	15			compact dry		Brn F SAND, sm F gravel	
	6	ss	24"	13"	12'0"	10	9			compact moist		LtBrn FM SAND, sm F gravel	
						7	5			compact			
15	7	ss	24"	16"	17'0"	10	3			wet loose		GreyBrn F SAND	
						2	2						
20	8	ss	24"	14"	22'0"	3	5			wet compact		GreyBrnBlk F SAND	
						6	3						
25	9	ss	24"	15"	27'0"	2	3			wet loose	27'0"	Grey FM SAND, lit F gravel	
						2	2						
30												E.O.B 27'0"	
35													
40													

NOTE: Subsoil conditions revealed by this investigation represent conditions at specific locations and may not represent conditions at other locations or times.

GROUND SURFACE TO _____ FT. USED _____ CASING THEN _____ CASING TO _____ FT. **HOLE NO. B-12**

A = AUGER UP = UNDISTURBED PISTON T = THINWALL V = VANE TEST
 WOR = WEIGHT OF RODS WOH = WEIGHT OF HAMMER & RODS C = COARSE
 SS = SPLIT TUBE SAMPLER H.S.A. = HOLLOW STEM AUGER M = MEDIUM
 PROPORTIONS USED: TRACE = 0 - 10% LITTLE = 10 - 20% SOME = 20 - 35% AND = 35 - 50% F = FINE

SOILTESTING, INC. 90 DONOVAN RD. OXFORD, CT 06478 CT (203) 262-9328 NY (914) 946-4850	CLIENT: KG&D Architects & Engineers	SHEET <u>1</u> OF <u>1</u>
	PROJECT NO. G211-1671-20	HOLE NO. B-13
	PROJECT NAME Former St Denis Parochial School	BORING LOCATIONS per Plan
FOREMAN - DRILLER JK/eq	LOCATION Van Cortlandt Park Ave & Lawrence St Yonkers, NY	
INSPECTOR	CASING TYPE HSA SAMPLER SS* CORE BAR	OFFSET
GROUND WATER OBSERVATIONS AT <u>11'0"</u> FT AFTER <u>0</u> HOURS	SIZE I.D. 4 1/4" 1 3/8"	DATE START 12/18/20
AT <u> </u> FT AFTER <u> </u> HOURS	HAMMER WT. 140# BIT	DATE FINISH 12/18/20
	HAMMER FALL 30"	SURFACE ELEV. EI. ±81.1
		GROUND WATER ELEV. EI. ±70.1

DEPTH	CASING BLOWS PER FOOT	SAMPLE					BLOWS PER 6 IN ON SAMPLER (FORCE ON TUBE)			CORE TIME PER FT (MIN)	DENSITY OR CONSIST	STRATA CHANGE DEPTH	FIELD IDENTIFICATION OF SOIL REMARKS INCL. COLOR, LOSS OF WASH WATER, SEAMS IN ROCK, ETC.
		NO	Type	PEN	REC	DEPTH @ BOT	0 - 6	6 - 12	12 - 18				
5		1	ss	24"	6"	20"	5	4			moist loose	6'0"	BrnRed FM SAND, lit silt, tr asphalt
		2	ss	24"	5"	4'0"	3	2			moist loose		SAME
		3	ss	24"	4"	6'0"	7	5			dry loose		Brn FM SAND, lit silt, tr brick, tr F gravel (fill)
		4	ss	24"	5"	8'0"	3	2			dry compact		
10		5	ss	24"	4"	10'0"	11	10			dry dense		Brn FM SAND, sm F gravel, tr silt
		6	ss	1"	0"	10'1"	10	15			v dense		Brn FM SAND & F GRAVEL
15							20	22					No recovery C GRAVEL @ 10'
		7	ss	24"	11"	17'0"	50/1				wet loose		Brn FM SAND, tr silt
20							4	5					
		8	ss	24"	12"	22'0"					wet compact		Grey VFF SAND
25							11	13					
		9	ss	24"	20"	27'0"					wet dense	27'0"	Grey F SAND
30							14	17					
							17	14					
35													
40													

NOTE: Subsoil conditions revealed by this investigation represent conditions at specific locations and may not represent conditions at other locations or times.

GROUND SURFACE TO _____ FT. USED _____ CASING THEN _____ CASING TO _____ FT.	HOLE NO. B-13
A = AUGER UP = UNDISTURBED PISTON T = THINWALL V = VANE TEST	
WOR = WEIGHT OF RODS WOH = WEIGHT OF HAMMER & RODS	C = COARSE
SS = SPLIT TUBE SAMPLER H.S.A. = HOLLOW STEM AUGER	M = MEDIUM
PROPORTIONS USED: TRACE = 0 - 10% LITTLE = 10 - 20% SOME = 20 - 35% AND = 35 - 50%	F = FINE

SOILTESTING, INC. 90 DONOVAN RD. OXFORD, CT 06478 CT (203) 262-9328 NY (914) 946-4850	CLIENT: KG&D Architects & Engineers	SHEET <u>1</u> OF <u>1</u> HOLE NO. B-14
	PROJECT NO. G211-1671-20	
	PROJECT NAME Former St Denis Parochial School	BORING LOCATIONS per Plan
FOREMAN - DRILLER MK/jk	LOCATION Van Cortlandt Park Ave & Lawrence St Yonkers, NY	
INSPECTOR	CASING TYPE HSA SAMPLER SS* CORE BAR	OFFSET
GROUND WATER OBSERVATIONS AT <u>11</u> ' FT AFTER <u>0</u> HOURS	SIZE I.D. 4 1/4" 1 3/8"	DATE START 12/4/20
AT <u> </u> ' FT AFTER <u> </u> HOURS	HAMMER WT. 140# BIT	DATE FINISH 12/4/20
	HAMMER FALL 30"	SURFACE ELEV. EI. ±81.2
		GROUND WATER ELEV. EI. ±70.2

DEPTH	CASING BLOWS PER FOOT	SAMPLE					BLOWS PER 6 IN ON SAMPLER (FORCE ON TUBE)			CORE TIME PER FT (MIN)	DENSITY OR CONSIST	STRATA CHANGE DEPTH	FIELD IDENTIFICATION OF SOIL REMARKS INCL. COLOR, LOSS OF WASH WATER, SEAMS IN ROCK, ETC.
		NO	Type	PEN	REC	DEPTH @ BOT	0-6	6-12	12-18				
5		1	ss	24"	0"	12"	4	41		moist v dense		2" Asphalt, no recovery	
						50/2"							
		2	ss	24"	10"	5'0"	5	2		moist loose		Brn F SAND, lit FC gravel, tr silt (possible fill)	
		3	ss	24"	10"	7'0"	3	3		moist loose	6'6"	Brn F SAND, tr FC gravel (possible fill)	
10		4	ss	24"	18"	9'0"	14	12		moist compact		Brn VF SAND	
							14	17					
		5	ss	24"	20"	12'0"	8	7		wet compact		Brn VF SAND	
							8	6					
15		6	ss	24"	18"	17'0"	3	3		wet loose		Brn F SAND	
							4	5					
20		7	ss	24"	16"	22'0"	3	4		wet loose		Grey F SAND	
							4	6					
25		8	ss	24"	16"	27'0"	3	4		wet loose		Grey F SAND	
							5	5			27'0"		
30												E.O.B 27'0"	
35													
40													

NOTE: Subsoil conditions revealed by this investigation represent conditions at specific locations and may not represent conditions at other locations or times.

GROUND SURFACE TO _____ FT. USED _____ CASING THEN _____ CASING TO _____ FT.	HOLE NO. B-14
A = AUGER UP = UNDISTURBED PISTON T = THINWALL V = VANE TEST	
WOR = WEIGHT OF RODS WOH = WEIGHT OF HAMMER & RODS	C = COARSE
SS = SPLIT TUBE SAMPLER H.S.A. = HOLLOW STEM AUGER	M = MEDIUM
PROPORTIONS USED: TRACE = 0 - 10% LITTLE = 10 - 20% SOME = 20 - 35% AND = 35 - 50%	F = FINE

SOILTESTING, INC. 90 DONOVAN RD. OXFORD, CT 06478 CT (203) 262-9328 NY (914) 946-4850	CLIENT: KG&D Architects & Engineers	SHEET <u>1</u> OF <u>1</u>
	PROJECT NO. G211-1671-20	HOLE NO. B-15
	PROJECT NAME Former St Denis Parochial School	BORING LOCATIONS per Plan
FOREMAN - DRILLER JK/eq	LOCATION Van Cortlandt Park Ave & Lawrence St Yonkers, NY	
INSPECTOR	CASING SAMPLER CORE BAR	OFFSET
GROUND WATER OBSERVATIONS AT <u>11</u> FT AFTER <u>0</u> HOURS	TYPE HSA SS*	DATE START 12/18/20
AT <u> </u> FT AFTER <u> </u> HOURS	SIZE I.D. 4 1/4" 1 3/8"	DATE FINISH 12/18/20
	HAMMER WT. 140# BIT	SURFACE ELEV. EI. ±80.8
	HAMMER FALL 30"	GROUND WATER ELEV. EI. ±69.8

DEPTH	CASING BLOWS PER FOOT	SAMPLE					BLOWS PER 6 IN ON SAMPLER (FORCE ON TUBE)			CORE TIME PER FT (MIN)	DENSITY OR CONSIST	STRATA CHANGE DEPTH	FIELD IDENTIFICATION OF SOIL REMARKS INCL. COLOR, LOSS OF WASH WATER, SEAMS IN ROCK, ETC.
		NO	Type	PEN	REC.	DEPTH @ BOT	0 - 6	6 - 12	12 - 18				
5	1	ss	24"	10"	2'0"	5	4			moist	2'0"	LtBrn SILT & F SAND (possible fill)	
						4	2			stiff			
	2	ss	24"	15"	4'0"	2	4			moist		Brn FM SAND, sm silt, lit C sand (possible fill)	
						2	5			loose			
	3	ss	24"	14"	6'0"	6	9			moist		Brn F SAND, sm MC sand, lit VF sand	
						11	11			compact			
	4	ss	24"	16"	8'0"	11	12			dry		Brn F SAND, lit VF sand	
						12	10			compact			
	5	ss	24"	18"	10'0"	10	11			dry		LtBrn VFF SAND	
10	6	ss	24"	18"	12'0"	8	9			compact		Brn F SAND, sm VF sand, lit M sand	
					7	5			wet				
									compact				
15	7	ss	24"	22"	17'0"	1	2			wet		LtBrnGrey F SAND, sm VF sand	
						2	3			v loose			
20	8	ss	24"	18"	22'0"	5	5			wet		Grey F SAND, sm VF sand, lit M sand	
						9	11			compact			
25	9	ss	24"	0"	27'0"	3	4			wet		No recovery	
						6	4			loose	27'0"		
30												E.O.B 27'0"	
35													
40													

NOTE: Subsoil conditions revealed by this investigation represent conditions at specific locations and may not represent conditions at other locations or times.

GROUND SURFACE TO _____ FT. USED _____ CASING THEN _____ CASING TO _____ FT. **HOLE NO. B-15**

A = AUGER UP = UNDISTURBED PISTON T = THINWALL V = VANE TEST
 WOR = WEIGHT OF RODS WOH = WEIGHT OF HAMMER & RODS C = COARSE
 SS = SPLIT TUBE SAMPLER H.S.A. = HOLLOW STEM AUGER M = MEDIUM
 PROPORTIONS USED: TRACE = 0 - 10% LITTLE = 10 - 20% SOME = 20 - 35% AND = 35 - 50% F = FINE

* SAFETY HAMMER CATHEAD & ROPE

SOILTESTING, INC. 90 DONOVAN RD. OXFORD, CT 06478 CT (203) 262-9328 NY (914) 946-4850	CLIENT: KG&D Architects & Engineers	SHEET <u>1</u> OF <u>1</u>
	PROJECT NO. G211-1671-20	HOLE NO. B-16
	PROJECT NAME Former St Denis Parochial School	BORING LOCATIONS per Plan
FOREMAN - DRILLER JK/eq	LOCATION Van Cortlandt Park Ave & Lawrence St Yonkers, NY	
INSPECTOR	CASING HSA SAMPLER SS* CORE BAR	OFFSET
GROUND WATER OBSERVATIONS AT <u>12</u> FT AFTER <u>0</u> HOURS	TYPE	DATE START 12/18/20
AT <u> </u> FT AFTER <u> </u> HOURS	SIZE I.D. <u>4 1/4"</u> <u>1 3/8"</u>	DATE FINISH 12/18/20
	HAMMER WT. <u>140#</u> BIT	SURFACE ELEV. EI. +81.0
	HAMMER FALL <u>30"</u>	GROUND WATER ELEV. EI. +69.0

DEPTH	CASING BLOWS PER FOOT	SAMPLE					BLOWS PER 6 IN ON SAMPLER (FORCE ON TUBE)			CORE TIME PER FT (MIN)	DENSITY OR CONSIST	STRATA CHANGE DEPTH	FIELD IDENTIFICATION OF SOIL REMARKS INCL. COLOR, LOSS OF WASH WATER, SEAMS IN ROCK, ETC.
		NO	Type	PEN	REC.	DEPTH @ BOT	0 - 6	6 - 12	12 - 18				
5	1	ss	24"	8"	2'0"	2	4			moist loose		LtBrn FM SAND, lit silt, lit F gravel	
	2	ss	24"	6"	4'0"	3	4			noist compact		LtBrn FM SAND, sm F gravel, lit silt	
						3	4			compact moist		LtBrn FM SAND, lit silt, tr F gravel	
	4	ss	24"	12"	6'0"	7	8			compact moist		LtBrn FM SAND, lit silt, tr F gravel	
						11	12			compact dry		LtBrnOrng FM SAND, tr silt, tr F gravel	
13						13			compact dry		LtBrn VFF SAND		
10	5	ss	24"	20"	10'0"	11	13			compact dry		LtBrn VFF SAND	
						14	16			compact moist		LtBrnGrey F SAND, sm VF sand	
						7	8			compact			
15	7	ss	24"	16"	17'0"	3	3			wet loose		BrnLtBrn FM SAND, tr silt, tr F gravel	
						3	6						
20	8	ss	24"	14"	22'0"	6	10			wet compact		Grey F SAND, lit M sand	
						11	14						
25	9	ss	24"	24"	27'0"	16	15			wet dense		Grey FM SAND, sm C sand	
						17	19					27'0"	
30												E.O.B 27'0"	
35													
40													* SAFETY HAMMER CATHEAD & ROPE

NOTE: Subsoil conditions revealed by this investigation represent conditions at specific locations and may not represent conditions at other locations or times.

GROUND SURFACE TO _____ FT. USED _____ CASING THEN _____ CASING TO _____ FT.	HOLE NO. B-16
A = AUGER UP = UNDISTURBED PISTON T = THINWALL V = VANE TEST	
WOR = WEIGHT OF RODS WOH = WEIGHT OF HAMMER & RODS	C = COARSE
SS = SPLIT TUBE SAMPLER H.S.A. = HOLLOW STEM AUGER	M = MEDIUM
PROPORTIONS USED: TRACE = 0 - 10% LITTLE = 10 - 20% SOME = 20 - 35% AND = 35 - 50%	F = FINE

SOILTESTING, INC. 90 DONOVAN RD. OXFORD, CT 06478 CT (203) 262-9328 NY (914) 946-4850	CLIENT: KG&D Architects & Engineers	SHEET <u>1</u> OF <u>1</u>
	PROJECT NO. G211-1671-20	HOLE NO. B-17
	PROJECT NAME Former St Denis Parochial School	BORING LOCATIONS per Plan
FOREMAN - DRILLER JK/eq	LOCATION Van Cortlandt Park Ave & Lawrence St Yonkers, NY	
INSPECTOR	CASING TYPE HSA SAMPLER SS* CORE BAR	OFFSET
GROUND WATER OBSERVATIONS AT <u>12</u> FT AFTER <u>0</u> HOURS	SIZE I.D. 4 1/4" 1 3/8"	DATE START 12/18/20
AT <u> </u> FT AFTER <u> </u> HOURS	HAMMER WT. 140# BIT	DATE FINISH 12/18/20
	HAMMER FALL 30"	SURFACE ELEV. EI. ±81.0
		GROUND WATER ELEV. EI. ±69.0

DEPTH	CASING BLOWS PER FOOT	SAMPLE					BLOWS PER 6 IN ON SAMPLER (FORCE ON TUBE)			CORE TIME PER FT (MIN)	DENSITY OR CONSIST	STRATA CHANGE DEPTH	FIELD IDENTIFICATION OF SOIL REMARKS INCL. COLOR, LOSS OF WASH WATER, SEAMS IN ROCK, ETC.
		NO	Type	PEN	REC	DEPTH @ BOT	0-6	6-12	12-18				
5	1	ss	24"	10"	2'0"	16	11			dry		BlkBrn FMC SAND, lit silt	
	2	ss	24"	8	4'0"	9	7			compact		Brn FM SAND, lit silt	
						5	4			compact			
	3	ss	24"	14"	6'0"	3	4			dry		LtBrn F SAND, lit M sand, tr VF sand	
						5	16			loose			
11						8			dry		LtBrn VFF SAND		
10	5	ss	24"	20"	10'0"	9	11			compact		LtBrn VFF SAND, lit F gravel	
						9	12			compact			
	6	ss	24"	21"	12'0"	11	9			moist		Brn F SAND, sm VF sand	
						10	11			compact			
15	7	ss	24"	11"	17'0"	1	2			wet		Brn F SAND, lit M sand, tr VF sand	
						3	4			loose			
20	8	ss	24"	23"	22'0"	4	6			wet		Grey F SAND, sm M sand, lit VF sand	
						9	10			compact			
25	9	ss	24"	12"	27'0"	3	4			wet		Grey FM SAND	
						7	9			compact	27'0"		
30												E.O.B 27'0"	
35												* SAFETY HAMMER CATHEAD & ROPE	
40												* SAFETY HAMMER CATHEAD & ROPE	

NOTE: Subsoil conditions revealed by this investigation represent conditions at specific locations and may not represent conditions at other locations or times.

GROUND SURFACE TO _____ FT. USED _____ CASING THEN _____ CASING TO _____ FT. **HOLE NO. B-17**

A = AUGER UP = UNDISTURBED PISTON T = THINWALL V = VANE TEST
 WOR = WEIGHT OF RODS WOH = WEIGHT OF HAMMER & RODS C = COARSE
 SS = SPLIT TUBE SAMPLER H.S.A. = HOLLOW STEM AUGER M = MEDIUM
 PROPORTIONS USED: TRACE = 0 - 10% LITTLE = 10 - 20% SOME = 20 - 35% AND = 35 - 50% F = FINE

SOILTESTING, INC. 90 DONOVAN RD. OXFORD, CT 06478 CT (203) 262-9328 NY (914) 946-4850	CLIENT: KG&D Architects & Engineers	SHEET <u>1</u> OF <u>1</u>
	PROJECT NO. G211-1671-20	HOLE NO. B-18
	PROJECT NAME Former St Denis Parochial School	BORING LOCATIONS per Plan
FOREMAN - DRILLER MKJao	LOCATION Van Cortlandt Park Ave & Lawrence St Yonkers, NY	
INSPECTOR	CASING TYPE HSA	SAMPLER SS*
GROUND WATER OBSERVATIONS AT <u>10</u> FT AFTER <u>0</u> HOURS	SIZE I.D. 4 1/4"	CORE BAR BIT
AT <u> </u> FT AFTER <u> </u> HOURS	HAMMER WT. 140#	OFFSET
	HAMMER FALL 30"	DATE START 1/4/21
		DATE FINISH 1/4/21
		SURFACE ELEV. EI. ±78.8
		GROUND WATER ELEV. EI. ±68.8

DEPTH	CASING BLOWS PER FOOT	SAMPLE					BLOWS PER 6 IN ON SAMPLER (FORCE ON TUBE)			CORE TIME PER FT (MIN)	DENSITY OR CONSIST	STRATA CHANGE DEPTH	FIELD IDENTIFICATION OF SOIL REMARKS INCL. COLOR, LOSS OF WASH WATER, SEAMS IN ROCK, ETC.
		NO	Type	PEN	REC	DEPTH @ BOT	0-6	6-12	12-18				
5	1	ss	24"	14"	2'0"	2	3			moist	4'0"	6" Topsoil	
	2	ss	24"	18"	4'0"	3	5			loose		Brn F SAND, sm silt, tr F gravel, tr brick	
						5	4			loose		Brn F SAND, str F gravel, tr brick (fill)	
	3	ss	24"	16"	6'0"	8	10			moist		Brn F SAND	
10	4	ss	24"	16"	8'0"	12	12			compact		SAME	
						14	16			moist		SAME	
	5	ss	24"	20"	10'0"	6	6			moist		SAME	
	6	ss	24"	18"	12'0"	5	7			compact		SAME	
6						5			wet				
15	7	ss	24"	24"	17'0"	6	5			wet	27'0"	OrgBrn F SAND	
						5	7			loose			
	8	ss	24"	24"	22'0"	3	4			wet		Brn F SAND	
						4	11			loose			
9	ss	24"	24"	27'0"	7	7			wet	SAME			
					12	10			compact				
30												E.O.B 27'0"	
35													
40													

NOTE: Subsoil conditions revealed by this investigation represent conditions at specific locations and may not represent conditions at other locations or times.

GROUND SURFACE TO _____ FT.	USED _____ CASING	THEN _____ CASING TO _____ FT.	HOLE NO. B-18
A = AUGER	UP = UNDISTURBED PISTON	T = THINWALL	V = VANE TEST
WOR = WEIGHT OF RODS	WOH = WEIGHT OF HAMMER & RODS	C = COARSE	M = MEDIUM
SS = SPLIT TUBE SAMPLER	H.S.A. = HOLLOW STEM AUGER	F = FINE	
PROPORTIONS USED: TRACE = 0 - 10% LITTLE = 10 - 20% SOME = 20 - 35% AND = 35 - 50%			

SOILTESTING, INC. 90 DONOVAN RD. OXFORD, CT 06478 CT (203) 262-9328 NY (914) 946-4850	CLIENT: KG&D Architects & Engineers	SHEET <u>1</u> OF <u>1</u>
	PROJECT NO. G211-1671-20	HOLE NO. B-19
	PROJECT NAME Former St Denis Parochial School	BORING LOCATIONS per Plan
FOREMAN - DRILLER MK/ao	LOCATION Van Cortlandt Park Ave & Lawrence St Yonkers, NY	
INSPECTOR	CASING TYPE HSA	SAMPLER SS*
GROUND WATER OBSERVATIONS AT <u>10</u> FT AFTER <u>0</u> HOURS	SIZE I.D. 4 1/4"	1 3/8"
AT <u> </u> FT AFTER <u> </u> HOURS	HAMMER WT. 140#	BIT
	HAMMER FALL 30"	GROUND WATER ELEV. EI. ±69.1

DEPTH	CASING BLOWS PER FOOT	SAMPLE					BLOWS PER 6 IN ON SAMPLER (FORCE ON TUBE)			CORE TIME PER FT (MIN)	DENSITY OR CONSIST	STRATA CHANGE DEPTH ELEV	FIELD IDENTIFICATION OF SOIL REMARKS INCL. COLOR, LOSS OF WASH WATER, SEAMS IN ROCK, ETC.
		NO	Type	PEN	REC	DEPTH @ BOT	0 - 6	6 - 12	12 - 18				
5		1	ss	24"	14"	2'0"	1	2		moist		6" Topsoil	
							3	6		loose		Brn F SAND, tr F gravel	
5		2	ss	24"	12"	4'0"	8	5		moist		Brn F SAND, lit F gravel, tr silt	
							4	4		loose			
5		3	ss	24"	20"	6'0"	5	6		moist		GreyBrn F SAND	
							12	12		compact			
10		4	ss	24"	16"	8'0"	18	13		moist		Brn F SAND	
							12	13		compact			
10		5	ss	24"	18"	10'0"	8	7		moist		SAME	
							7	6		compact			
15		6	ss	24"	16"	12'0"	8	5		wet		SAME	
							5	6		loose			
20		7	ss	24"	22"	17'0"	2	3		wet		SAME	
							5	5		loose			
25		8	ss	24"	20"	22'0"	4	10		wet		SAME	
							14	14		compact			
30		9	ss	24"	22"	27'0"	3	5		wet		SAME	
							5	11		loose	27'0"		
30												E.O.B 27'0"	
35													
40													

NOTE: Subsoil conditions revealed by this investigation represent conditions at specific locations and may not represent conditions at other locations or times.

GROUND SURFACE TO _____ FT. USED _____ CASING THEN _____ CASING TO _____ FT.	HOLE NO. B-19
A = AUGER UP = UNDISTURBED PISTON T = THINWALL V = VANE TEST	
WOR = WEIGHT OF RODS WOH = WEIGHT OF HAMMER & RODS	C = COARSE
SS = SPLIT TUBE SAMPLER H.S.A. = HOLLOW STEM AUGER	M = MEDIUM
PROPORTIONS USED: TRACE = 0 - 10% LITTLE = 10 - 20% SOME = 20 - 35% AND = 35 - 50%	F = FINE

SOILTESTING, INC. 90 DONOVAN RD. OXFORD, CT 06478 CT (203) 262-9328 NY (914) 946-4850	CLIENT: KG&D Architects & Engineers	SHEET <u>1</u> OF <u>1</u>
	PROJECT NO. G211-1671-20	HOLE NO. B-20
	PROJECT NAME Former St Denis Parochial School	BORING LOCATIONS per Plan
FOREMAN - DRILLER MK/ao	LOCATION Van Cortlandt Park Ave & Lawrence St Yonkers, NY	
INSPECTOR	CASING TYPE HSA	SAMPLER SS*
GROUND WATER OBSERVATIONS AT <u>11</u> FT AFTER <u>0</u> HOURS	SIZE I.D. 4 1/4"	1 3/8"
AT <u> </u> FT AFTER <u> </u> HOURS	HAMMER WT. 140#	BIT
	HAMMER FALL 30"	CORE BAR
		OFFSET
		DATE START 1/4/21
		DATE FINISH 1/4/21
		SURFACE ELEV. EI. ±79.8
		GROUND WATER ELEV. EI. ±68.8

DEPTH	CASING BLOWS PER FOOT	SAMPLE					BLOWS PER 6 IN ON SAMPLER (FORCE ON TUBE)			CORE TIME PER FT (MIN)	DENSITY OR CONSIST	STRATA CHANGE DEPTH	FIELD IDENTIFICATION OF SOIL REMARKS INCL. COLOR, LOSS OF WASH WATER, SEAMS IN ROCK, ETC.
		NO	Type	PEN	REC	DEPTH @ BOT	0 - 6	6 - 12	12 - 18				
5	1	ss	24"	16"	20"	1	3			moist		8" Topsoil; Brn F SAND, tr F gravel (possible fill)	
						3	3			loose			
	2	ss	24"	14"	40"	2	3			moist/wet		Brn F SAND, lit F gravel, tr silt (possible fill)	
						3	2			loose			
	3	ss	24"	20"	6'0"	11	5			moist		GreyBrn F SAND, tr F gravel	
						5	6			loose			
	4	ss	24"	18"	8'0"	8	9			moist		Brn F SAND	
						12	12			compact			
	5	ss	24"	16"	10'0"	10	14			moist		Brn F SAND	
10					11	10			compact				
	6	ss	24"	17"	12'0"	9	8			moist/wet		SAME	
					7	8			compact				
15													
	7	ss	24"	22"	17'0"	3	4			wet		SAME	
						3	5			loose			
20													
	8	ss	24"	22"	22'0"	3	15			wet		SAME	
						14	12			compact			
25													
	9	ss	24"	24"	27'0"	4	3			wet		SAME	
						4	10			loose	27'0"		
30												E.O.B 27'0"	
35													
40													

NOTE: Subsoil conditions revealed by this investigation represent conditions at specific locations and may not represent conditions at other locations or times.

GROUND SURFACE TO _____ FT. USED _____ CASING THEN _____ CASING TO _____ FT.	HOLE NO. B-20
A = AUGER UP = UNDISTURBED PISTON T = THINWALL V = VANE TEST	
WOR = WEIGHT OF RODS WOH = WEIGHT OF HAMMER & RODS	C = COARSE
SS = SPLIT TUBE SAMPLER H.S.A. = HOLLOW STEM AUGER	M = MEDIUM
PROPORTIONS USED: TRACE = 0 - 10% LITTLE = 10 - 20% SOME = 20 - 35% AND = 35 - 50%	F = FINE

SOILTESTING, INC. 90 DONOVAN RD. OXFORD, CT 06478 CT (203) 262-9328 NY (914) 946-4850	CLIENT: KG&D Architects & Engineers	SHEET <u>1</u> OF <u>1</u>
	PROJECT NO. G211-1671-20	HOLE NO. B-21
	PROJECT NAME Former St Denis Parochial School	BORING LOCATIONS per Plan
FOREMAN - DRILLER MK/ao	LOCATION Van Cortlandt Park Ave & Lawrence St Yonkers, NY	
INSPECTOR	CASING TYPE HSA	SAMPLER SS*
GROUND WATER OBSERVATIONS AT <u>10</u> FT AFTER <u>0</u> HOURS	SIZE I.D. 4 1/4"	1 3/8"
AT <u> </u> FT AFTER <u> </u> HOURS	HAMMER WT. 140#	BIT
	HAMMER FALL 30"	GROUND WATER ELEV. EI. ±69.2

DEPTH	CASING BLOWS PER FOOT	SAMPLE					BLOWS PER 6 IN ON SAMPLER (FORCE ON TUBE)			CORE TIME PER FT (MIN)	DENSITY OR CONSIST	STRATA CHANGE DEPTH	FIELD IDENTIFICATION OF SOIL REMARKS INCL. COLOR, LOSS OF WASH WATER, SEAMS IN ROCK, ETC.
		NO	Type	PEN	REC	DEPTH @ BOT	0 - 6	6 - 12	12 - 18				
5		1	ss	24"	12"	2'0"	1	3		moist		6" Topsoil; Brn F SAND, sm F gravel	
							3	2		loose			
5		2	ss	24"	14"	4'0"	4	6		moist		OrgBrn F SAND, sm F gravel, tr silt	
							7	4		compact			
5		3	ss	24"	20"	6'0"	13	11		moist		OrgBrn F SAND	
							10	11		compact			
10		4	ss	24"	18"	8'0"	15	12		moist		SAME	
							12	15		compact			
10		5	ss	24"	18"	10'0"	10	6		moist		Brn F SAND	
							6	7		compact			
15		6	ss	24"	18"	12'0"	7	6		wet		SAME	
							6	4		compact			
20		7	ss	24"	16"	17'0"	2	4		wet		SAME	
							4	6		loose			
25		8	ss	24"	20"	22'0"	3	9		wet		SAME	
							12	16		compact			
30		9	ss	24"	20"	27'0"	4	4		wet		SAME	
							6	9		loose	27'0"		
30												E.O.B 27'0"	
35													
40													

NOTE: Subsoil conditions revealed by this investigation represent conditions at specific locations and may not represent conditions at other locations or times.

GROUND SURFACE TO _____ FT. USED _____ CASING THEN _____ CASING TO _____ FT. **HOLE NO. B-21**

A = AUGER UP = UNDISTURBED PISTON T = THINWALL V = VANE TEST
 WOR = WEIGHT OF RODS WOH = WEIGHT OF HAMMER & RODS C = COARSE
 SS = SPLIT TUBE SAMPLER H.S.A. = HOLLOW STEM AUGER M = MEDIUM
 PROPORTIONS USED: TRACE = 0 - 10% LITTLE = 10 - 20% SOME = 20 - 35% AND = 35 - 50% F = FINE

SOILTESTING, INC. 90 DONOVAN RD. OXFORD, CT 06478 CT (203) 262-9328 NY (914) 946-4850	CLIENT: KG&D Architects & Engineers	SHEET <u>1</u> OF <u>1</u>
	PROJECT NO. G211-1671-20	HOLE NO. B-22
	PROJECT NAME Former St Denis Parochial School	BORING LOCATIONS per Plan
FOREMAN - DRILLER MK/ao	LOCATION Van Cortlandt Park Ave & Lawrence St Yonkers, NY	
INSPECTOR	CASING TYPE HSA	SAMPLER SS*
GROUND WATER OBSERVATIONS AT <u>10</u> FT AFTER <u>0</u> HOURS	SIZE I.D. 4 1/4"	1 3/8"
AT <u> </u> FT AFTER <u> </u> HOURS	HAMMER WT. 140#	BIT
	HAMMER FALL 30"	GROUND WATER ELEV. EI. ±70.4

DEPTH	CASING BLOWS PER FOOT	SAMPLE					BLOWS PER 6 IN ON SAMPLER (FORCE ON TUBE)			CORE TIME PER FT (MIN)	DENSITY OR CONSIST	STRATA CHANGE DEPTH	FIELD IDENTIFICATION OF SOIL REMARKS INCL. COLOR, LOSS OF WASH WATER, SEAMS IN ROCK, ETC.
		NO	Type	PEN	REC	DEPTH @ BOT	0 - 6	6 - 12	12 - 18				
5		1	ss	24"	14"	2'0"	1	3			moist	6" Topsoil; Brn F SAND	
							3	4			loose		
		2	ss	24"	16"	4'0"	4	6			moist		SAME
							6	4			compact		
		3	ss	24"	18"	6'0"	5	6			moist		Brn FMC SAND, sm F gravel
10							10	10			compact	Brn F SAND	
		4	ss	24"	16"	8'0"	12	15			moist		
							15	13			compact		
		5	ss	24"	20"	10'0"	5	8			moist		SAME
							8	10			compact		
15							10	6			wet	SAME	
							5	5			compact		
		7	ss	24"	22"	17'0"	2	2			wet		
							3	5			loose		
20												SAME	
		8	ss	24"	24"	22'0"	4	5			wet		
							4	7			loose		
25												SAME	
		9	ss	24"	24"	27'0"	6	7			wet		
							6	5			compact		
30												E.O.B 27'0"	
35													
40													

NOTE: Subsoil conditions revealed by this investigation represent conditions at specific locations and may not represent conditions at other locations or times.

GROUND SURFACE TO _____ FT. USED _____ CASING THEN _____ CASING TO _____ FT.	HOLE NO. B-22
A = AUGER UP = UNDISTURBED PISTON T = THINWALL V = VANE TEST	
WOR = WEIGHT OF RODS WOH = WEIGHT OF HAMMER & RODS	C = COARSE
SS = SPLIT TUBE SAMPLER H.S.A. = HOLLOW STEM AUGER	M = MEDIUM
PROPORTIONS USED: TRACE = 0 - 10% LITTLE = 10 - 20% SOME = 20 - 35% AND = 35 - 50%	F = FINE

SOILTESTING, INC. 90 DONOVAN RD. OXFORD, CT 06478 CT (203) 262-9328 NY (914) 946-4850	CLIENT: KG&D Architects & Engineers	SHEET <u>1</u> OF <u>1</u>
	PROJECT NO. G211-1671-20	HOLE NO. B-23
	PROJECT NAME Former St Denis Parochial School	BORING LOCATIONS per Plan
FOREMAN - DRILLER MK/ao	LOCATION Van Cortlandt Park Ave & Lawrence St Yonkers, NY	
INSPECTOR	CASING TYPE HSA	SAMPLER SS*
GROUND WATER OBSERVATIONS AT <u>10</u> FT AFTER <u>0</u> HOURS	SIZE I.D. 4 1/4"	1 3/8"
AT <u> </u> FT AFTER <u> </u> HOURS	HAMMER WT. 140#	BIT
	HAMMER FALL 30"	GROUND WATER ELEV. EI. ±68.8

DEPTH	CASING BLOWS PER FOOT	SAMPLE					BLOWS PER 6 IN ON SAMPLER (FORCE ON TUBE)			CORE TIME PER FT (MIN)	DENSITY OR CONSIST	STRATA CHANGE DEPTH	FIELD IDENTIFICATION OF SOIL REMARKS INCL. COLOR, LOSS OF WASH WATER, SEAMS IN ROCK, ETC.
		NO	Type	PEN	REC	DEPTH @ BOT	0 - 6	6 - 12	12 - 18				
5		1	ss	24"	4"	2'0"	1	2		moist	4'0"	4" Topsoil	
		2	ss	24"	3"	4'0"	5	4		loose		Brn F SAND, sm silt (possible fill)	
							1	3		moist		SAME	
		3	ss	24"	18"	6'0"	3	3		loose			
							5	5		moist		GreyBrn F SAND	
10							5	7		loose	27'0"	Brn F SAND	
		4	ss	24"	18"	8'0"	12	10		moist		SAME	
							10	11		compact			
		5	ss	24"	16"	10'0"	5	6		moist		SAME	
							6	5		compact		SAME	
15							5	5		wet	27'0"	SAME	
							6	5		loose			
		7	ss	24"	18"	17'0"	3	3		wet		SAME	
							4	6		loose			
20											27'0"	SAME	
		8	ss	24"	24"	22'0"	4	5		wet		SAME	
							10	13		compact			
25											27'0"	SAME	
		9	ss	24"	24"	27'0"	4	5		wet		SAME	
							7	7		compact			
30											E.O.B 27'0"		
35													
40													

NOTE: Subsoil conditions revealed by this investigation represent conditions at specific locations and may not represent conditions at other locations or times.

GROUND SURFACE TO _____ FT. USED _____ CASING THEN _____ CASING TO _____ FT.	HOLE NO. B-23
A = AUGER UP = UNDISTURBED PISTON T = THINWALL V = VANE TEST	
WOR = WEIGHT OF RODS WOH = WEIGHT OF HAMMER & RODS	C = COARSE
SS = SPLIT TUBE SAMPLER H.S.A. = HOLLOW STEM AUGER	M = MEDIUM
PROPORTIONS USED: TRACE = 0 - 10% LITTLE = 10 - 20% SOME = 20 - 35% AND = 35 - 50%	F = FINE

SOILTESTING, INC. 90 DONOVAN RD. OXFORD, CT 06478 CT (203) 262-9328 NY (914) 946-4850	CLIENT: KG&D Architects & Engineers	SHEET <u>1</u> OF <u>1</u>
	PROJECT NO. G211-1671-20	HOLE NO. B-24
	PROJECT NAME Former St Denis Parochial School	BORING LOCATIONS per Plan
FOREMAN - DRILLER MK/ao	LOCATION Van Cortlandt Park Ave & Lawrence St Yonkers, NY	
INSPECTOR	CASING TYPE HSA	SAMPLER SS*
GROUND WATER OBSERVATIONS AT <u>10</u> FT AFTER <u>0</u> HOURS	SIZE I.D. 4 1/4"	1 3/8"
AT <u> </u> FT AFTER <u> </u> HOURS	HAMMER WT. 140#	BIT
	HAMMER FALL 30"	GROUND WATER ELEV. EI. ±69.5

DEPTH	CASING BLOWS PER FOOT	SAMPLE					BLOWS PER 6 IN ON SAMPLER (FORCE ON TUBE)			CORE TIME PER FT (MIN)	DENSITY OR CONSIST	STRATA CHANGE DEPTH	FIELD IDENTIFICATION OF SOIL REMARKS INCL. COLOR, LOSS OF WASH WATER, SEAMS IN ROCK, ETC.
		NO	Type	PEN	REC.	DEPTH @ BOT	0 - 6	6 - 12	12 - 18				
5		1	ss	24"	14"	2'0"	1	3		moist	5'0"	6" Topsoil; Brn FM SAND, tr F gravel, concrete	
		2	ss	24"	0"	4'0"	4	2		loose		No recovery (fill)	
		3	ss	24"	4"	6'0"	3	3		v loose			
10		4	ss	24"	16"	8'0"	17	12		loose	27'0"	Grey F SAND, lit FC gravel	
		5	ss	24"	16"	10'0"	13	11		moist		Brn F SAND	
		6	ss	24"	20"	12'0"	9	6		compact		SAME	
15							6	5		wet			
		7	ss	24"	24"	17'0"	3	2		loose	SAME		
							3	5					
20													
		8	ss	24"	24"	22'0"	3	4		wet	SAME		
							4	6		loose			
25													
		9	ss	24"	22"	27'0"	5	7		wet	SAME		
							7	9		compact			
30													
												E.O.B 27'0"	
35													
40													

NOTE: Subsoil conditions revealed by this investigation represent conditions at specific locations and may not represent conditions at other locations or times.

GROUND SURFACE TO _____ FT. USED _____ CASING THEN _____ CASING TO _____ FT.	HOLE NO. B-24
A = AUGER UP = UNDISTURBED PISTON T = THINWALL V = VANE TEST	
WOR = WEIGHT OF RODS WOH = WEIGHT OF HAMMER & RODS C = COARSE	
SS = SPLIT TUBE SAMPLER H.S.A. = HOLLOW STEM AUGER M = MEDIUM	
PROPORTIONS USED: TRACE = 0 - 10% LITTLE = 10 - 20% SOME = 20 - 35% AND = 35 - 50%	F = FINE

SOILTESTING, INC. 90 DONOVAN RD. OXFORD, CT 06478 CT (203) 262-9328 NY (914) 946-4850	CLIENT: KG&D Architects & Engineers	SHEET <u>1</u> OF <u>2</u>
	PROJECT NO. G211-1671-20	HOLE NO. B-26
FOREMAN - DRILLER MK/ao/ak	PROJECT NAME Former St Denis Parochial School	BORING LOCATIONS per Plan
INSPECTOR	LOCATION Van Cortlandt Park Ave & Lawrence St Yonkers, NY	
GROUND WATER OBSERVATIONS AT <u>10</u> FT AFTER <u>0</u> HOURS AT <u> </u> FT AFTER <u> </u> HOURS	CASING SAMPLER CORE BAR TYPE NW SS* SIZE I.D. 3" 1 3/8" HAMMER WT. 300" 140# BIT HAMMER FALL 24" 30"	OFFSET DATE START 1/6/21 DATE FINISH 1/7/21 SURFACE ELEV. EI. ±79.2 GROUND WATER ELEV. EI. ±69.2

DEPTH	CASING BLOWS PER FOOT	SAMPLE					BLOWS PER 6 IN ON SAMPLER (FORCE ON TUBE)				CORE TIME PER FT (MIN)	DENSITY OR CONSIST	STRATA CHANGE DEPTH	FIELD IDENTIFICATION OF SOIL REMARKS INCL. COLOR, LOSS OF WASH WATER, SEAMS IN ROCK, ETC.
		NO	Type	PEN	REC	DEPTH @ BOT	0-6	6-12	12-18	MOIST				
5	1	ss	24"	14"	20"	1	2				moist loose		10" Topsoil	
	2	ss	24"	12"	40"	2	3				moist loose		Brn F SAND, lit F gravel (possible fill)	
	3	ss	24"	16"	60"	3	3				moist compact		Brn F SAND, sm silt (possible fill)	
	4	ss	24"	14"	80"	9	9				moist compact		DkBrn F SAND	
	5	ss	24"	14"	100"	11	13				moist compact		Brn F SAND	
10	6	ss	24"	18"	120"	13	15				moist compact		SAME	
	7	ss	24"	24"	170"	7	7				wet compact		SAME	
	8	ss	24"	22"	220"	6	7				wet compact		SAME	
20	9	ss	24"	24"	270"	2	2				wet v loose		SAME	
	10	ss	24"	0"	320"	2	3				wet loose		SAME	
	11	ss	24"	12"	370"	3	3				wet compact		SAME	
30	12	ss	24"	0"	320"	4	4				wet compact		SAME	
	13	ss	24"	0"	320"	8	8				wet compact		SAME	
	14	ss	24"	0"	320"	6	7				wet compact		No recovery	
35	15	ss	24"	12"	370"	8	6				wet compact		Brn F SAND	
	16	ss	24"	12"	370"	7	9				wet compact		Brn F SAND	
	17	ss	24"	12"	370"	8	5				wet compact		Brn F SAND	

NOTE: Subsoil conditions revealed by this investigation represent conditions at specific locations and may not represent conditions at other locations or times.

GROUND SURFACE TO _____ FT. USED _____ CASING THEN _____ CASING TO _____ FT. **HOLE NO. B-26**

A = AUGER UP = UNDISTURBED PISTON T = THINWALL V = VANE TEST
 WOR = WEIGHT OF RODS WOH = WEIGHT OF HAMMER & RODS C = COARSE
 SS = SPLIT TUBE SAMPLER H.S.A. = HOLLOW STEM AUGER M = MEDIUM
 PROPORTIONS USED: TRACE = 0 - 10% LITTLE = 10 - 20% SOME = 20 - 35% AND = 35 - 50% F = FINE

SOILTESTING, INC. 90 DONOVAN RD. OXFORD, CT 06478 CT (203) 262-9328 NY (914) 946-4850	CLIENT: KG&D Architects & Engineers	SHEET <u>2</u> OF <u>2</u>
	PROJECT NO. G211-1671-20	HOLE NO. B-26
	PROJECT NAME Former St Denis Parochial School	BORING LOCATIONS per Plan
FOREMAN - DRILLER MK/ao/ak	LOCATION Van Cortlandt Park Ave & Lawrence St Yonkers, NY	
INSPECTOR	CASING TYPE NW	SAMPLER SS*
GROUND WATER OBSERVATIONS AT <u>10</u> FT AFTER <u>0</u> HOURS	SIZE I.D. 3"	1 3/8"
AT <u> </u> FT AFTER <u> </u> HOURS	HAMMER WT. 300"	140# BIT
	HAMMER FALL 24"	30"
		OFFSET
		DATE START 1/6/21
		DATE FINISH 1/7/21
		SURFACE ELEV. EI. ±79.2
		GROUND WATER ELEV. EI. ±69.2

DEPTH	CASING BLOWS PER FOOT	SAMPLE				DEPTH @ BOT	BLOWS PER 6 IN ON SAMPLER (FORCE ON TUBE)			CORE TIME PER FT (MIN)	DENSITY OR CONSIST	STRATA CHANGE DEPTH	FIELD IDENTIFICATION OF SOIL REMARKS INCL. COLOR, LOSS OF WASH WATER, SEAMS IN ROCK, ETC.
		NO	Type	PEN	REC		0-6	6-12	12-18				
45	12	ss	24"	14"	42'0"	7	7			wet compact		Brn F SAND	
						6	11						
50	13	ss	24"	16"	47'0"	7	8			wet compact		Brn F SAND	
						10	10						
55	14	ss	24"	14"	52'0"	7	7					SAME	
						9	10						
60	15	ss	24"	16"	57'0"	8	7			wet compact		SAME	
						9	11						
65	16	ss	24"	14"	62'0"	7	7			wet compact		Brn F SAND	
						8	10						
70	17	ss	24"	24"	67'0"	9	15			wet compact	67'0"	SAME	
						15	21						
75													
80													

NOTE: Subsoil conditions revealed by this investigation represent conditions at specific locations and may not represent conditions at other locations or times.

GROUND SURFACE TO _____ FT. USED _____ CASING THEN _____ CASING TO _____ FT.	HOLE NO. B-26
A = AUGER UP = UNDISTURBED PISTON T = THINWALL V = VANE TEST	
WOR = WEIGHT OF RODS WOH = WEIGHT OF HAMMER & RODS	C = COARSE
SS = SPLIT TUBE SAMPLER H.S.A. = HOLLOW STEM AUGER	M = MEDIUM
PROPORTIONS USED: TRACE = 0 - 10% LITTLE = 10 - 20% SOME = 20 - 35% AND = 35 - 50%	F = FINE

SOILTESTING, INC. 90 DONOVAN RD. OXFORD, CT 06478 CT (203) 262-9328 NY (914) 946-4850	CLIENT: KG&D Architects & Engineers	SHEET <u>1</u> OF <u>1</u> HOLE NO. B-27
	PROJECT NO. G211-1671-20	
	PROJECT NAME Former St Denis Parochial School	BORING LOCATIONS per Plan
FOREMAN - DRILLER MK/ao	LOCATION Van Cortlandt Park Ave & Lawrence St Yonkers, NY	
INSPECTOR	CASING TYPE HSA SAMPLER SS* CORE BAR	OFFSET
GROUND WATER OBSERVATIONS AT <u>10</u> FT AFTER <u>0</u> HOURS	SIZE I.D. 4 1/4" 1 3/8"	DATE START 1/5/21
AT <u> </u> FT AFTER <u> </u> HOURS	HAMMER WT. 140# BIT	DATE FINISH 1/5/21
	HAMMER FALL 30"	SURFACE ELEV. EI. ±78.9
		GROUND WATER ELEV. EI. ±68.9

DEPTH	CASING BLOWS PER FOOT	SAMPLE					BLOWS PER 6 IN ON SAMPLER (FORCE ON TUBE)				CORE TIME PER FT (MIN)	DENSITY OR CONSIST	STRATA CHANGE DEPTH	FIELD IDENTIFICATION OF SOIL REMARKS INCL. COLOR, LOSS OF WASH WATER, SEAMS IN ROCK, ETC.
		NO	Type	PEN	REC	DEPTH @ BOT	0-6	6-12	12-18	MOIST				
5	1	ss	24"	12"	2'0"	1	2			moist		6" Topsoil; Brn F SAND, sm F gravel		
	2	ss	24"	14"	4'0"	3	3			loose		LtBrn F SAND, lit silt, lit gravel		
						4	5			loose				
	3	ss	24"	16"	6'0"	6	6			moist		Brn F SAND		
						7	8			compact				
11						12			moist					
4	ss	24"	18"	8'0"	11	12			compact		LtBrn F SAND			
					11	11			compact					
					6	8			moist					
5	ss	24"	20"	10'0"	7	6			compact		Brn F SAND			
					7	6			compact					
					5	7			wet					
6	ss	24"	18"	12'0"	5	7			compact		SAME			
					7	5			compact					
7	ss	24"	22"	17'0"	3	3					SAME			
					4	4								
8	ss	24"	24"	22'0"	4	6			wet		SAME			
					6	7			compact					
9	ss	24"	22"	27'0"	6	4			wet		SAME			
					4	4			loose					
									27'0"					
30											E.O.B 27'0"			
35														
40												* SAFETY HAMMER CATHEAD & ROPE		

NOTE: Subsoil conditions revealed by this investigation represent conditions at specific locations and may not represent conditions at other locations or times.

GROUND SURFACE TO _____ FT. USED _____ CASING THEN _____ CASING TO _____ FT. HOLE NO. **B-27**

A = AUGER UP = UNDISTURBED PISTON T = THINWALL V = VANE TEST
 WOR = WEIGHT OF RODS WOH = WEIGHT OF HAMMER & RODS C = COARSE
 SS = SPLIT TUBE SAMPLER H.S.A. = HOLLOW STEM AUGER M = MEDIUM
 PROPORTIONS USED: TRACE = 0 - 10% LITTLE = 10 - 20% SOME = 20 - 35% AND = 35 - 50% F = FINE

SOILTESTING, INC. 90 DONOVAN RD. OXFORD, CT 06478 CT (203) 262-9328 NY (914) 946-4850	CLIENT: KG&D Architects & Engineers	SHEET <u>1</u> OF <u>1</u>
	PROJECT NO. G211-1671-20	HOLE NO. B-28
	PROJECT NAME Former St Denis Parochial School	BORING LOCATIONS per Plan
FOREMAN - DRILLER MK/ao	LOCATION Van Cortlandt Park Ave & Lawrence St Yonkers, NY	
INSPECTOR	CASING TYPE HSA SAMPLER SS* CORE BAR	OFFSET
GROUND WATER OBSERVATIONS AT <u>10</u> FT AFTER <u>0</u> HOURS	SIZE I.D. 4 1/4" 1 3/8"	DATE START 1/5/21
AT <u> </u> FT AFTER <u> </u> HOURS	HAMMER WT. 140# BIT	DATE FINISH 1/5/21
	HAMMER FALL 30"	SURFACE ELEV. EI. ±79.1
		GROUND WATER ELEV. EI. ±69.1

DEPTH	CASING BLOWS PER FOOT	SAMPLE					BLOWS PER 6 IN ON SAMPLER (FORCE ON TUBE)			CORE TIME PER FT (MIN)	DENSITY OR CONSIST	STRATA CHANGE DEPTH	FIELD IDENTIFICATION OF SOIL REMARKS INCL. COLOR, LOSS OF WASH WATER, SEAMS IN ROCK, ETC.
		NO	Type	PEN	REC	DEPTH @ BOT	0 - 6	6 - 12	12 - 18				
5	1	ss	24"	14"	20"	1	1			moist	4'6"	6" Topsoil; Brn F SAND, tr F gravel	
	2	ss	24"	10"	4'0"	3	5			v loose		Brn F SAND, tr gravel, tr brick (fill)	
	3	ss	24"	16"	6'0"	2	2			moist		SAME	
	4	ss	24"	16"	8'0"	7	10			compact		OrgBrn F SAND	
	5	ss	24"	16"	10'0"	12	14			moist		Brn F SAND	
10	6	ss	24"	18"	12'0"	14	15			compact	27'0"	SAME	
	7	ss	24"	22"	17'0"	7	10			compact		SAME	
	8	ss	24"	24"	22'0"	10	7			wet		SAME	
15	9	ss	24"	24"	27'0"	7	8			compact	27'0"	SAME	
	10	ss	24"	22"	17'0"	5	4			wet		SAME	
20	11	ss	24"	24"	22'0"	3	5			loose	27'0"	SAME	
	12	ss	24"	24"	22'0"	4	6			wet		SAME	
25	13	ss	24"	24"	22'0"	6	5			compact	27'0"	SAME	
	14	ss	24"	24"	27'0"	4	6			wet		SAME	
30	15	ss	24"	24"	27'0"	6	7			compact	27'0"	SAME	
	16	ss	24"	24"	27'0"	4	6			wet		SAME	
35	17	ss	24"	24"	27'0"	6	7			compact	27'0"	SAME	
	18	ss	24"	24"	27'0"	4	6			wet		SAME	
40	19	ss	24"	24"	27'0"	6	7			compact	27'0"	SAME	
	20	ss	24"	24"	27'0"	4	6			wet		SAME	

NOTE: Subsoil conditions revealed by this investigation represent conditions at specific locations and may not represent conditions at other locations or times.

GROUND SURFACE TO _____ FT. USED _____ CASING THEN _____ CASING TO _____ FT. **HOLE NO. B-28**

A = AUGER UP = UNDISTURBED PISTON T = THINWALL V = VANE TEST
 WOR = WEIGHT OF RODS WOH = WEIGHT OF HAMMER & RODS C = COARSE
 SS = SPLIT TUBE SAMPLER H.S.A. = HOLLOW STEM AUGER M = MEDIUM
 PROPORTIONS USED: TRACE = 0 - 10% LITTLE = 10 - 20% SOME = 20 - 35% AND = 35 - 50% F = FINE

SOILTESTING, INC. 90 DONOVAN RD. OXFORD, CT 06478 CT (203) 262-9328 NY (914) 946-4850	CLIENT: KG&D Architects & Engineers	SHEET <u>1</u> OF <u>1</u>
	PROJECT NO. G211-1671-20	HOLE NO. B-29
	PROJECT NAME Former St Denis Parochial School	BORING LOCATIONS per Plan
FOREMAN - DRILLER MK/ao	LOCATION Van Cortlandt Park Ave & Lawrence St Yonkers, NY	
INSPECTOR	CASING TYPE HSA	SAMPLER SS*
GROUND WATER OBSERVATIONS AT <u>10</u> FT AFTER <u>0</u> HOURS	SIZE I.D. 4 1/4"	1 3/8"
AT <u> </u> FT AFTER <u> </u> HOURS	HAMMER WT. 140#	BIT
	HAMMER FALL 30"	GROUND WATER ELEV. EI. ±69.9

DEPTH	CASING BLOWS PER FOOT	SAMPLE				DEPTH @ BOT	BLOWS PER 6 IN ON SAMPLER (FORCE ON TUBE)				CORE TIME PER FT (MIN)	DENSITY OR CONSIST	STRATA CHANGE DEPTH	FIELD IDENTIFICATION OF SOIL REMARKS INCL. COLOR, LOSS OF WASH WATER, SEAMS IN ROCK, ETC.
		NO	Type	PEN	REC.		0	6	12	18				
5	1	ss	24"	14"	2'0"	2	3				moist loose		6" Topsoil; Brn F SAND, tr F gravel, tr silt	
	2	ss	24"	8"	4'0"	2	2				moist v loose		SAME	
	3	ss	24"	20"	6'0"	3	5				moist compact		OrngBrn F SAND	
	4	ss	24"	16"	8'0"	9	10				moist compact		Brn F SAND	
	5	ss	24"	20"	10'0"	10	11				moist compact		Brn F SAND	
10	6	ss	24"	18"	12'0"	11	8				wet compact		SAME	
						9	8							
15	7	ss	24"	24"	17'0"	3	3				wet loose		SAME	
						7	6							
20	8	ss	24"	24"	22'0"	3	4				wet loose		SAME	
						4	3							
25	9	ss	24"	24"	27'0"	5	3				wet loose		SAME	
						4	3					27'0"		
30													E.O.B 27'0"	
35														
40														

NOTE: Subsoil conditions revealed by this investigation represent conditions at specific locations and may not represent conditions at other locations or times.

GROUND SURFACE TO _____ FT. USED _____ CASING THEN _____ CASING TO _____ FT.	HOLE NO. B-29
A = AUGER UP = UNDISTURBED PISTON T = THINWALL V = VANE TEST	
WOR = WEIGHT OF RODS WOH = WEIGHT OF HAMMER & RODS	C = COARSE
SS = SPLIT TUBE SAMPLER H.S.A. = HOLLOW STEM AUGER	M = MEDIUM
PROPORTIONS USED: TRACE = 0 - 10% LITTLE = 10 - 20% SOME = 20 - 35% AND = 35 - 50%	F = FINE

SOILTESTING, INC. 90 DONOVAN RD. OXFORD, CT 06478 CT (203) 262-9328 NY (914) 946-4850	CLIENT: KG&D Architects & Engineers	SHEET <u>1</u> OF <u>1</u>
	PROJECT NO. G211-1671-20	HOLE NO. D-1
	PROJECT NAME Former St Denis Parochial School	BORING LOCATIONS per Plan
FOREMAN - DRILLER JK/eq	LOCATION Van Cortlandt Park Ave & Lawrence St Yonkers, NY	
INSPECTOR	CASING TYPE HSA	SAMPLER SS
GROUND WATER OBSERVATIONS AT <u>12</u> FT AFTER <u>0</u> HOURS	SIZE I.D. 2 1/2"	1 3/8"
AT <u> </u> FT AFTER <u> </u> HOURS	HAMMER WT. 140#	BIT
	HAMMER FALL 30"	CORE BAR
		OFFSET
		DATE START 12/21/20
		DATE FINISH 12/21/20
		SURFACE ELEV. EI. ±80.8
		GROUND WATER ELEV. EI. ±68.8

DEPTH	CASING BLOWS PER FOOT	SAMPLE					BLOWS PER 6 IN ON SAMPLER (FORCE ON TUBE)				CORE TIME PER FT (MIN)	DENSITY OR CONSIST	STRATA CHANGE DEPTH	FIELD IDENTIFICATION OF SOIL REMARKS INCL. COLOR, LOSS OF WASH WATER, SEAMS IN ROCK, ETC.
		NO	Type	PEN	REC.	DEPTH @ BOT	0 - 6	6 - 12	12 - 18	MOIST				
5	1	ss	24"	16"	20"	1	2			moist v loose	8'0"	Bm FM SAND, sm silt, tr F gravel		
						2	2							
10	2	ss	24"	22"	7'0"	6	9			dry compact		LtBrn F SAND, sm MC sand, tr F gravel, tr brick (fill)		
						12	18							
15	3	ss	24"	21"	12'0"	8	6			moist loose		LtBrnOrg F SAND, sm VF sand, lit M sand		
						4	4							
20	4	ss	24"	20"	17'0"	2	2			wet loose		Grey FM SAND, lit C sand		
						3	4							
25	5	ss	24"	21"	22'0"	3	5			wet compact		GreyLtBrn FM SAND		
						6	7							
30	6	ss	24"	0"	27'0"	2	2			wet v loose	27'0"	No recovery		
						2	1							
35												E.O.B 27'0"		
40														

NOTE: Subsoil conditions revealed by this investigation represent conditions at specific locations and may not represent conditions at other locations or times.

GROUND SURFACE TO _____ FT. USED _____ CASING THEN _____ CASING TO _____ FT. **HOLE NO. D-1**

A = AUGER UP = UNDISTURBED PISTON T = THINWALL V = VANE TEST
 WOR = WEIGHT OF RODS WOH = WEIGHT OF HAMMER & RODS C = COARSE
 SS = SPLIT TUBE SAMPLER H.S.A. = HOLLOW STEM AUGER M = MEDIUM
 PROPORTIONS USED: TRACE = 0 - 10% LITTLE = 10 - 20% SOME = 20 - 35% AND = 35 - 50% F = FINE

SOILTESTING, INC. 90 DONOVAN RD. OXFORD, CT 06478 CT (203) 262-9328 NY (914) 946-4850	CLIENT: KG&D Architects & Engineers	SHEET <u>1</u> OF <u>1</u>
	PROJECT NO. G211-1671-20	HOLE NO. D-2
	PROJECT NAME Former St Denis Parochial School	BORING LOCATIONS per Plan
FOREMAN - DRILLER PD/ak/rc	LOCATION Van Cortlandt Park Ave & Lawrence St Yonkers, NY	
INSPECTOR	CASING TYPE HSA SAMPLER SS* CORE BAR	OFFSET
GROUND WATER OBSERVATIONS AT <u>11</u> ' FT AFTER <u>0</u> HOURS	SIZE I.D. 2 1/2" 1 3/8"	DATE START 1/4/21
AT <u> </u> ' FT AFTER <u> </u> HOURS	HAMMER WT. 140# BIT	DATE FINISH 1/4/21
	HAMMER FALL 30"	SURFACE ELEV. EI. ±78.3
		GROUND WATER ELEV. EI. ±67.3

DEPTH	CASING BLOWS PER FOOT	SAMPLE				BLOWS PER 6 IN ON SAMPLER (FORCE ON TUBE) 0-6 6-12 12-18	CORE TIME PER FT (MIN)	DENSITY OR CONSIST M	STRATA CHANGE DEPTH ELEV	FIELD IDENTIFICATION OF SOIL REMARKS INCL. COLOR, LOSS OF WASH WATER, SEAMS IN ROCK, ETC.
		NO	Type	PEN	REC					
5		1	ss	24"	12"	2'0"	1 2	moist loose	3'0"	12" Topsoil DkBrnGrey VFFM SAND, lit FC gravel
						3 3				
10		2	ss	24"	20"	7'0"	6 13	moist v stiff	5'6"	OrngBrn SILT & FM SAND
						12 14				
15		3	ss	24"	18"	12'0"	4 4	moist/vmoist loose		LtBrn FM SAND
						4 5				
20		4	ss	24"	18"	17'0"	3 4	wet loose		GreyBrn FM SAND
						4 4				
25		5	ss	24"	18"	22'0"	3 3	wet loose		SAME
						4 4				
30		6	ss	24"	17"	27'0"	2 3	wet loose	27'0"	LtBrn Grey FM SAND
						3 4				
35										
40										

NOTE: Subsoil conditions revealed by this investigation represent conditions at specific locations and may not represent conditions at other locations or times.

GROUND SURFACE TO _____ FT. USED _____ CASING THEN _____ CASING TO _____ FT.	HOLE NO. D-2
A = AUGER UP = UNDISTURBED PISTON T = THINWALL V = VANE TEST	
WOR = WEIGHT OF RODS WOH = WEIGHT OF HAMMER & RODS	C = COARSE
SS = SPLIT TUBE SAMPLER H.S.A. = HOLLOW STEM AUGER	M = MEDIUM
PROPORTIONS USED: TRACE = 0 - 10% LITTLE = 10 - 20% SOME = 20 - 35% AND = 35 - 50%	F = FINE

* SAFETY HAMMER CATHEAD & ROPE

SOILTESTING, INC. 90 DONOVAN RD. OXFORD, CT 06478 CT (203) 262-9328 NY (914) 946-4850	CLIENT: KG&D Architects & Engineers	SHEET <u>1</u> OF <u>1</u>
	PROJECT NO. G211-1671-20	HOLE NO. D-3
	PROJECT NAME Former St Denis Parochial School	BORING LOCATIONS per Plan
FOREMAN - DRILLER PD/ak/rc	LOCATION Van Cortlandt Park Ave & Lawrence St Yonkers, NY	
INSPECTOR	CASING SAMPLER CORE BAR	OFFSET
GROUND WATER OBSERVATIONS AT <u>10</u> FT AFTER <u>0</u> HOURS	TYPE HSA SS*	DATE START 1/4/21
AT <u> </u> FT AFTER <u> </u> HOURS	SIZE I.D. 2 1/2" 1 3/8"	DATE FINISH 1/4/21
	HAMMER WT. 140# BIT	SURFACE ELEV. EI. ±79.8
	HAMMER FALL 30"	GROUND WATER ELEV. EI. ±69.8

DEPTH	CASING BLOWS PER FOOT	SAMPLE					BLOWS PER 6 IN ON SAMPLER (FORCE ON TUBE)		CORE TIME PER FT (MIN)	DENSITY OR CONSIST M OIST	STRATA CHANGE DEPTH ELEV	FIELD IDENTIFICATION OF SOIL REMARKS INCL. COLOR, LOSS OF WASH WATER, SEAMS IN ROCK, ETC.
		NO	Type	PEN	REC.	DEPTH @ BOT	0 - 6	6 - 12				
5	1	ss	24"	20"	2'6"	2	2		moist/vmoist loose	0'6"	2" Asphalt, Process stone	
						3	3					
10	2	ss	24"	18"	7'0"	7	9		moist/vmoist compact	5'0"	LtBrnLtGrey VFF SAND	
						7	10					
15	3	ss	24"	18"	12'0"	2	3		moist/vmoist loose		LtBrnLtGrey VFFM SAND	
						2	3					
20	4	ss	24"	20"	17'0"	3	3		wet loose		LtBrnLtGrey VFFMC SAND	
						4	4					
25	5	ss	24"	15"	22'0"	3	3		wet loose		SAME	
						4	4					
30	6	ss	24"	18"	27'0"	3	4		wet loose	27'0"	SAME	
						4	4					
35											E.O.B 27'0"	
40											* SAFETY HAMMER CATHEAD & ROPE	

NOTE: Subsoil conditions revealed by this investigation represent conditions at specific locations and may not represent conditions at other locations or times.

GROUND SURFACE TO _____ FT. USED _____ CASING THEN _____ CASING TO _____ FT.	HOLE NO. D-3
A = AUGER UP = UNDISTURBED PISTON T = THINWALL V = VANE TEST	
WOR = WEIGHT OF RODS WOH = WEIGHT OF HAMMER & RODS	C = COARSE
SS = SPLIT TUBE SAMPLER H.S.A. = HOLLOW STEM AUGER	M = MEDIUM
PROPORTIONS USED: TRACE = 0 - 10% LITTLE = 10 - 20% SOME = 20 - 35% AND = 35 - 50%	F = FINE

Test Pit Logs

SOILTESTING, INC. 90 DONOVAN RD. OXFORD, CT 06478 CT (203) 262-9328 NY (914) 946-4850	CLIENT: KG&D Architects & Engineers	SHEET <u>1</u> OF <u>1</u> HOLE NO. TP A-1
	PROJECT NO. G211-1671-20	BORING LOCATIONS plan
PROJECT NAME Former St. Denis Parochial School		
FOREMAN - DRILLER PD/ak/rc	LOCATION Van Cortlandt Park Ave & Lawrence St Yonkers, NY	OFFSET
INSPECTOR James DeAngelis	TEST PITS EXCAVATOR	DATE START 1/6/21
GROUND WATER OBSERVATIONS AT <u>none</u> FT AFTER 12 HOURS AT <u> </u> FT AFTER <u> </u> HOURS		DATE FINISH 1/6/21
		SURFACE ELEV. GROUND WATER ELEV.

TEST pit - A-1

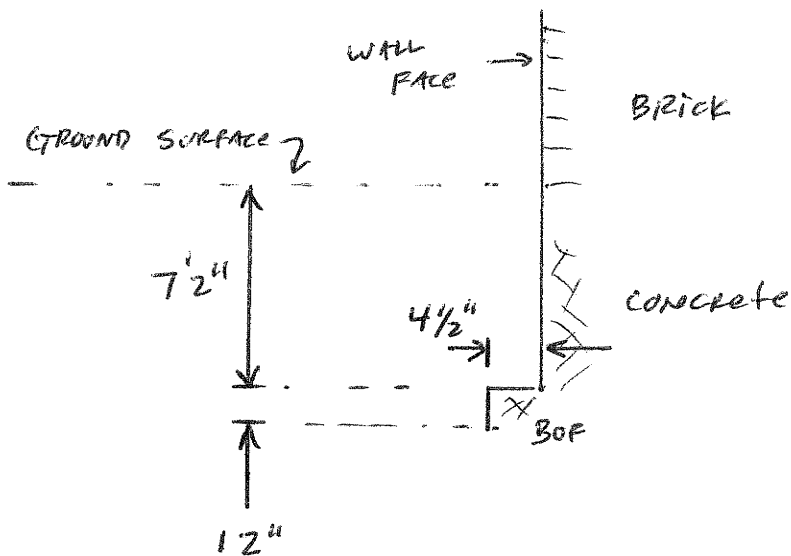

SOILTESTING, INC. 90 DONOVAN RD. OXFORD, CT 06478 CT (203) 262-9328 NY (914) 946-4850	CLIENT: KG&D Architects & Engineers	SHEET <u>1</u> OF <u>1</u> HOLE NO. TP A-2
	PROJECT NO. G211-1671-20	BORING LOCATIONS , plan
PROJECT NAME Former St. Denis Parochial School		
FOREMAN - DRILLER PD/ak/rc	LOCATION Van Cortlandt Park Ave & Lawrence St Yonkers, NY	OFFSET
INSPECTOR James DeAngelis	TEST PITS EXCAVATOR	DATE START 1/6/21
GROUND WATER OBSERVATIONS AT <u>none</u> FT AFTER <u>12</u> HOURS AT <u> </u> FT AFTER <u> </u> HOURS		DATE FINISH 1/6/21
		SURFACE ELEV. GROUND WATER ELEV.

TEST PIT - A-2

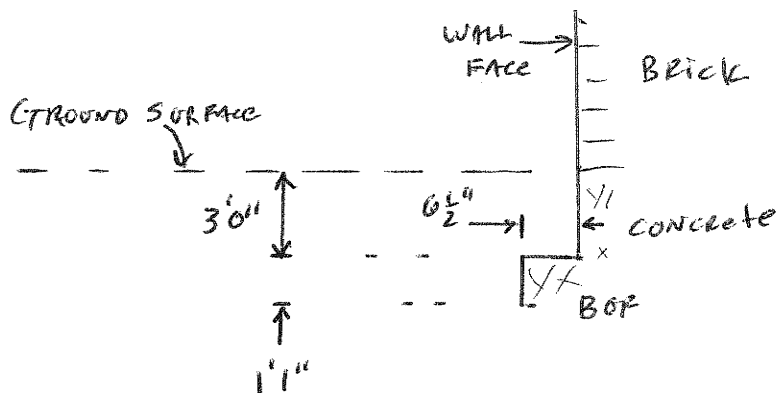

SOILTESTING, INC. 90 DONOVAN RD. OXFORD, CT 06478 CT (203) 262-9328 NY (914) 946-4850	CLIENT: KG&D Architects & Engineers	SHEET <u>1</u> OF <u>1</u> HOLE NO. TP-A3
	PROJECT NO. G211-1671-20	BORING LOCATIONS plan
PROJECT NAME Former St. Denis Parochial School		
FOREMAN - DRILLER PD/ak/rc	LOCATION Van Cortlandt Park Ave & Lawrence St Yonkers, NY	OFFSET
INSPECTOR James DeAngelis	TEST PITS EXCAVATOR	DATE START 1/6/21
GROUND WATER OBSERVATIONS AT <u>none</u> FT AFTER <u>12</u> HOURS AT <u> </u> FT AFTER <u> </u> HOURS		DATE FINISH 1/6/21
		SURFACE ELEV. GROUND WATER ELEV.

TEST pit - A-3

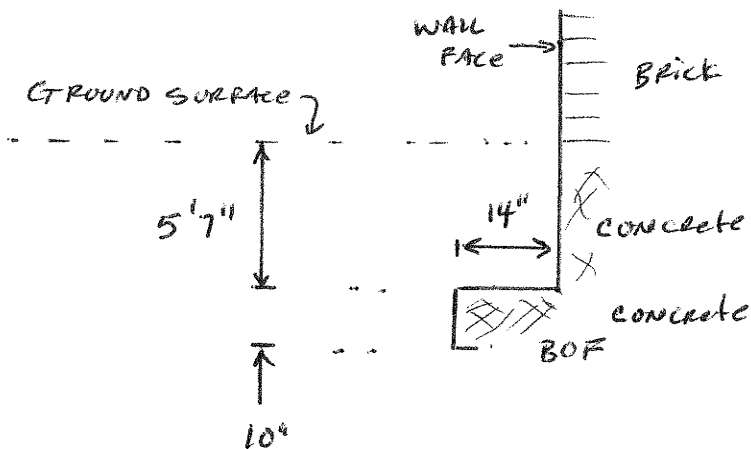

SOILTESTING, INC. 90 DONOVAN RD. OXFORD, CT 06478 CT (203) 262-9328 NY (914) 946-4850	CLIENT: KG&D Architects & Engineers	SHEET <u>1</u> OF <u>1</u> HOLE NO. TP-A4
	PROJECT NO. G211-1671-20	BORING LOCATIONS plan
	PROJECT NAME Former St. Denis Parochial School	
FOREMAN - DRILLER PD/ak/rc	LOCATION Van Cortlandt Park Ave & Lawrence St Yonkers, NY	
INSPECTOR James DeAngelis	TEST PITS EXCAVATOR	OFFSET
GROUND WATER OBSERVATIONS AT <u>10'</u> FT AFTER <u>12</u> HOURS AT <u> </u> FT AFTER <u> </u> HOURS		DATE START 1/6/21
		DATE FINISH 1/6/21
	SURFACE ELEV. GROUND WATER ELEV.	

TEST PIT - A-4

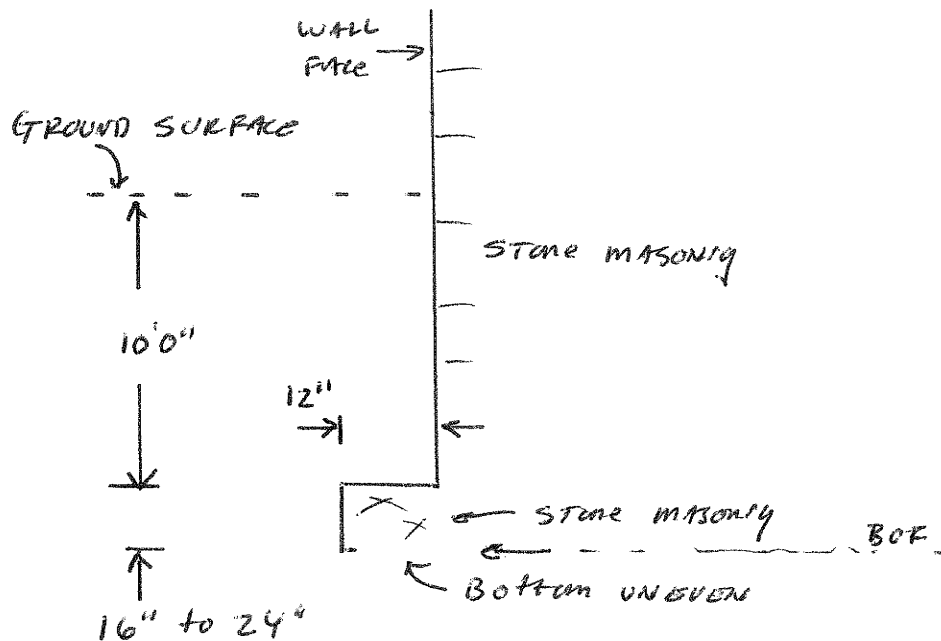

NOTE: EXCAVATE UNSTABLE, F-SAND

∴ WATER WEEPING AT 10' DEPTH

Field Permeability Test Results

**ST. DENIS COMMUNITY SCHOOL
YONKERS, NY**

PERMEABILITY TEST RESULTS

Boring	Ground Elev., ft.	Test	Hole Diam., in.	Test Depth, ¹		Stickup, in.	Test Elev., ft.	Soil Immediately Below Test Depth	N-value	Water Depth	Water Depth	Δ Time, min.	Permeability (in./hr)	
				in Casing at t ₀ , in.	in Casing at t ₁₀₀ , in.					in./hr	cm/s			
C-1	El. 80.9	1	4.0	96.00	8.00	30	72.9	Brown silty f SAND	NR	99	114	14	3.970	2.80E-03
		2	4.0	96.00	8.00	30		Brown silty f SAND	NR	98	116.5	20	3.704	2.61E-03
		3	4.0	96.00	8.00	30		Brown silty f SAND	NR	99	121	25	4.624	3.26E-03
C-2	El. 78.6	1	4.0	96.00	8.00	30	70.6	Brown f SAND	NR	91	119.5	5	23.079	1.63E-02
		2	4.0	96.00	8.00	30		Brown f SAND	NR	97	117	4	20.050	1.41E-02
		3	4.0	96.00	8.00	30		Brown f SAND	NR	98	118	4	21.467	1.51E-02
C-3	El. 79.8	1	4.0	96.00	8.00	30	71.8	Brown f SAND	NR	96	119	10	9.975	7.04E-03
		2	4.0	96.00	8.00	30		Brown f SAND	NR	96	110	5	8.617	6.08E-03
		3	4.0	96.00	8.00	30		Brown f SAND	NR	97	116	7	10.426	7.36E-03
		4	4.0	96.00	8.00	30		Brown f SAND	NR	98	117	7	11.114	7.84E-03

Notes: 1) Test Depth is measured from the ground surface to the bottom of hole

SOILTESTING, INC. 90 DONOVAN RD. OXFORD, CT 06478 CT (203) 262-9328 NY (914) 946-4850	CLIENT: KG&D Architects & Engineers	SHEET <u>1</u> OF <u>1</u>
	PROJECT NO. G211-1671-20	HOLE NO. C-1
	PROJECT NAME Former St Denis Parochial School	BORING LOCATIONS per Plan
FOREMAN - DRILLER JK/eq	LOCATION Van Cortlandt Park Ave & Lawrence St Yonkers, NY	
INSPECTOR	CASING SAMPLER CORE BAR	OFFSET
	TYPE <u>HW</u> <u>SS*</u>	DATE START 12/23/20
GROUND WATER OBSERVATIONS	SIZE I.D. <u>4"</u> <u>1 3/8"</u>	DATE FINISH 12/23/20
AT <u>none</u> FT AFTER <u>0</u> HOURS	HAMMER WT. <u>140#</u> <u>BIT</u>	SURFACE ELEV. EI. ±80.8
AT <u> </u> FT AFTER <u> </u> HOURS	HAMMER FALL <u>30"</u>	GROUND WATER ELEV.

DEPTH	CASING BLOWS PER FOOT	SAMPLE					BLOWS PER 6 IN ON SAMPLER (FORCE ON TUBE) 0 - 6 6 - 12 12- 18	CORE TIME PER FT (MIN)	DENSITY OR CONSIST	STRATA CHANGE DEPTH	FIELD IDENTIFICATION OF SOIL REMARKS INCL. COLOR, LOSS OF WASH WATER, SEAMS IN ROCK, ETC.		
		NO	Type	PEN	REC	DEPTH @ BOT						MOIST	ELEV
5									8'0"	2" Asphalt 4" Gravel Base Brn VFFM SAND, lit silt			
10										E.O.B 8'0"			
15													
20													
25													
30													
35													
40													

NOTE: Subsoil conditions revealed by this investigation represent conditions at specific locations and may not represent conditions at other locations or times.

GROUND SURFACE TO _____ FT. USED _____ CASING THEN _____ CASING TO _____ FT.	HOLE NO. C-1
A = AUGER UP = UNDISTURBED PISTON T = THINWALL V = VANE TEST	
WOR = WEIGHT OF RODS WOH = WEIGHT OF HAMMER & RODS	C = COARSE
SS = SPLIT TUBE SAMPLER H.S.A. = HOLLOW STEM AUGER	M = MEDIUM
PROPORTIONS USED: TRACE = 0 - 10% LITTLE = 10 - 20% SOME = 20 - 35% AND = 35 - 50%	F = FINE

SOILTESTING, INC.

90 DONOVAN RD.
 OXFORD, CT 06478
 CT (203) 262-9328
 NY (914) 946-4850

CLIENT:

KGTD ARCHITECTS & ENGRS

PROJECT NO.

G 211-1671-20

PROJECT NAME

FORMER ST. DENIS PAROCHIAL SCHOOL

LOCATION

VAN CORTLANDT PARK AVE & LAWRENCE ST, YONKERS, NY.

PERCOLATION TEST

BORING / PERCOLATION TEST LOCATION:

C-1

CASING DIAMETER:

4"

TECHNICIAN:

JAMES DEANGELO

OVERALL CASING LENGTH:

10'6"

TEST DATE:

1-5-2021

CASING STICK-UP (A.G. SURFACE):

2'6"

ADJACENT OBSERVATION WELL GROUNDWATER LEVEL READING:

N/A

Depth to Groundwater Level

(Date:

and Time:)

PRESOAK DATE:

12-23-20

TIME	WATER LEVEL from TOP of CASING	NOTES
9:25 AM	None	AFTER PRE-SOAK
9:27	8'3"	INITIAL FILL
9:34	8'11"	
9:41	9'6"	15" / 14 min
11:40	8'2"	2 ND FILL
11:45	8'7"	
11:50	8'11 1/2"	
11:55	9'4"	
12:00	9'8 1/2"	18 1/2" / 20
12:04	8'3"	3 RD FILL
12:14	9'0"	
12:19	9'4 1/2"	
12:24	9'9"	
12:29	10'1"	22" / 25 min
		PERC RATE:
		22" / 25 min
		52" / HOUR

COMMENTS:

ALL WATER LEVEL READINGS FROM TOP OF CASING

SOILTESTING, INC. 90 DONOVAN RD. OXFORD, CT 06478 CT (203) 262-9328 NY (914) 946-4850	CLIENT: KG&D Architects & Engineers	SHEET <u>1</u> OF <u>1</u>
	PROJECT NO. G211-1671-20	HOLE NO. C-2
	PROJECT NAME Former St Denis Parochial School	BORING LOCATIONS per Plan
FOREMAN - DRILLER PD/ak/rc	LOCATION Van Cortlandt Park Ave & Lawrence St Yonkers, NY	
INSPECTOR	CASING SAMPLER CORE BAR	OFFSET
GROUND WATER OBSERVATIONS AT <u>none</u> FT AFTER <u>0</u> HOURS AT <u> </u> FT AFTER <u> </u> HOURS	TYPE HW SS*	DATE START 1/4/21
	SIZE I.D. 4" 1 3/8"	DATE FINISH 1/4/21
	HAMMER WT. 140# BIT	SURFACE ELEV. El. ±78.6
	HAMMER FALL 30"	GROUND WATER ELEV.

DEPTH	CASING BLOWS PER FOOT	SAMPLE					BLOWS PER 6 IN ON SAMPLER (FORCE ON TUBE) 0 - 6 6 - 12 12 - 18	CORE TIME PER FT (MIN)	DENSITY OR CONSIST	STRATA CHANGE DEPTH	FIELD IDENTIFICATION OF SOIL REMARKS INCL. COLOR, LOSS OF WASH WATER, SEAMS IN ROCK, ETC.
		NO	Type	PEN	REC	DEPTH @ BOT					
5										Bm VFFM SAND	
10									8'0"	E.O.B 8'0"	
15											
20											
25											
30											
35											
40										* SAFETY HAMMER CATHEAD & ROPE	

NOTE: Subsoil conditions revealed by this investigation represent conditions at specific locations and may not represent conditions at other locations or times.

GROUND SURFACE TO _____ FT. USED _____ CASING THEN _____ CASING TO _____ FT.	HOLE NO. C-2
A = AUGER UP = UNDISTURBED PISTON T = THINWALL V = VANE TEST	
WOR = WEIGHT OF RODS WOH = WEIGHT OF HAMMER & RODS	C = COARSE
SS = SPLIT TUBE SAMPLER H.S.A. = HOLLOW STEM AUGER	M = MEDIUM
PROPORTIONS USED: TRACE = 0 - 10% LITTLE = 10 - 20% SOME = 20 - 35% AND = 35 - 50%	F = FINE

SOILTESTING, INC.

90 DONOVAN RD.
 OXFORD, CT 06478
 CT (203) 262-9328
 NY (914) 946-4850

CLIENT:

KGTD ARCHITECTS & ENGRS

PROJECT NO.

G 211-1671-20

PROJECT NAME

Former ST. DENIS PAROCHIAL SCHOOL

LOCATION

VAN CORTLANDT PARK AVE & LAWRENCE ST, YONKERS, NY.

PERCOLATION TEST

BORING / PERCOLATION TEST LOCATION:

C-2

CASING DIAMETER:

4"

TECHNICIAN:

JAMES DEANGELO

OVERALL CASING LENGTH:

10'6"

TEST DATE:

1-5-2021

CASING STICK-UP (A.G. SURFACE):

2'6"

ADJACENT OBSERVATION WELL GROUNDWATER LEVEL READING:

N/A

Depth to Groundwater Level

(Date:

and Time:

)

PRESOAK DATE:

1-4-2021

TIME	WATER LEVEL from TOP of CASING	NOTES	
9:47am	NONE	AFTER PRE-SOAK	
9:50	8'	INITIAL FILL	
10:10	NONE		
10:16	7'7"] F	
10:17	8'3"		2 ND FILL
10:18	8'10"		
10:19	9'4"		
10:21	9'11 1/2"		
11:01	8'1"	3 RD FILL	
11:03	8'11"		
11:05	9'9"	20" / 4 min	
11:11	8'2"	4 TH FILL	
11:15	9'10"	20" / 4 min	
		PERC RATE:	
		20" / 4 min	
		300" / HOUR	

COMMENTS:

ALL WATER LEVEL READINGS FROM TOP OF CASING

SOILTESTING, INC. 90 DONOVAN RD. OXFORD, CT 06478 CT (203) 262-9328 NY (914) 946-4850	CLIENT: KG&D Architects & Engineers	SHEET <u>1</u> OF <u>1</u>
	PROJECT NO. G211-1671-20	HOLE NO. C-3
	PROJECT NAME Former St Denis Parochial School	BORING LOCATIONS per Plan
FOREMAN - DRILLER PD/ak/rc	LOCATION Van Cortlandt Park Ave & Lawrence St Yonkers, NY	
INSPECTOR	CASING SAMPLER CORE BAR	OFFSET
	TYPE HW SS*	DATE START 1/4/21
GROUND WATER OBSERVATIONS	SIZE I.D. 4" 1 3/8"	DATE FINISH 1/4/21
AT <u>none</u> FT AFTER <u>0</u> HOURS	HAMMER WT. 140# BIT	SURFACE ELEV. El. ±79.8
AT <u> </u> FT AFTER <u> </u> HOURS	HAMMER FALL 30"	GROUND WATER ELEV.

DEPTH	CASING BLOWS PER FOOT	SAMPLE					BLOWS PER 6 IN ON SAMPLER (FORCE ON TUBE) 0 - 6 6 - 12 12 - 18	CORE TIME PER FT (MIN)	DENSITY OR CONSIST	STRATA CHANGE DEPTH	FIELD IDENTIFICATION OF SOIL REMARKS INCL. COLOR, LOSS OF WASH WATER, SEAMS IN ROCK, ETC.
		NO	Type	PEN	REC	DEPTH @ BOT					
5										Brn VFFM SAND	
10									8'0"	E.O.B 8'0"	
15											
20											
25											
30											
35											
40											

NOTE: Subsoil conditions revealed by this investigation represent conditions at specific locations and may not represent conditions at other locations or times.

GROUND SURFACE TO _____ FT. USED _____ CASING THEN _____ CASING TO _____ FT.	HOLE NO. C-3
A = AUGER UP = UNDISTURBED PISTON T = THINWALL V = VANE TEST	
WOR = WEIGHT OF RODS WOH = WEIGHT OF HAMMER & RODS	C = COARSE
SS = SPLIT TUBE SAMPLER H.S.A. = HOLLOW STEM AUGER	M = MEDIUM
PROPORTIONS USED: TRACE = 0 - 10% LITTLE = 10 - 20% SOME = 20 - 35% AND = 35 - 50%	F = FINE

SOILTESTING, INC.

90 DONOVAN RD.
 OXFORD, CT 06478
 CT (203) 262-9328
 NY (914) 946-4850

CLIENT:

KGTD ARCHITECTS & ENGRS

PROJECT NO.

G 211-1671-20

PROJECT NAME

Former ST. DENIS PAROCHIAL SCHOOL

LOCATION

VAN CORTLANDT PARK AVE & LAWRENCE ST, YONKERS, NY.

PERCOLATION TEST

BORING / PERCOLATION TEST LOCATION: **C-3**

CASING DIAMETER: **4"**

TECHNICIAN:

JAMES DEANGELO

OVERALL CASING LENGTH: **10'6"**

TEST DATE:

1-5-2021

CASING STICK-UP (A.G. SURFACE): **2'6"**

ADJACENT OBSERVATION WELL GROUNDWATER LEVEL READING: **N/A**

Depth to Groundwater Level

(Date: _____ and Time: _____)

PRESOAK DATE: **1-4-2021**

TIME	WATER LEVEL from TOP of CASING	NOTES
10:31 am	None	AFTER PRE-SOAK
10:34	8'0"	INITIAL Fill
10:36	8'7"	
10:39	9'1"	
10:42	9'6 1/2"	
10:44	9'11"	23" / 10 min
10:45	6'0"	2 nd Fill
10:51	8'0"	
10:56	9'2"	14" / 5 min
11:17	8'1"	3 rd Fill
11:22	9'3"	
11:24	9'8"	19" / 7 min
11:27	8'2"	4 th Fill
11:34	9'9"	19" / 7 min
		PERC RATE:
		19" / 7 min
		163" / Hour

COMMENTS:

All WATER LEVEL READINGS FROM TOP OF CASING

The following additions, substitutions, or clarifications are extracted from the (5) Bid Addenda issued with this project during bidding. This insert is intended to summarize addendum information relevant to this specification section. See Bid Addenda issued by the City of Yonkers for complete contract document changes.

Bid Addendum No. 1:

Contract No. 1 – General Construction Work: On page 4 add the following to become 12.i” - “i. City of Yonkers Bidder’s Affidavit”

Bid Addendum No. 2:

Contract No. 1 – General Construction Work: Replace the section issued with the bid documents with the one attached to this addendum.

BID FORM - REVISED ADDENDUM NO. 2
FOR
COMMUNITY SCHOOL 35
CONTRACT NO. 1 - GENERAL CONSTRUCTION WORK

Yonkers Joint Schools Construction Board
City Hall
40 South Broadway
Yonkers, NY 10701
Attention: Marlyn Anderson, Secretary

(Deliver Bids To: Yonkers Bureau of Purchasing, One Larkin Center, 3rd Floor, Yonkers, N.Y. 10701)

1. The Undersigned hereby declares that it has carefully examined all Bidding and Contract Documents and has inspected the actual location of Work, together with the local sources of supply, and has satisfied itself as to all quantities and conditions, and understands that in signing this Proposal, it waives all rights to plead any misunderstanding regarding the same.
2. The Undersigned further understands and agrees that it is to do, perform and complete all the Work in accordance with the Contract Documents and Contract and to accept in full compensation therefor, the amount of the Total Base Bid, modified by such additive or deductive alternatives, if any, as are accepted by the Owner.
3. In submitting this Bid, the Undersigned agrees:
 - a. To hold the Bid open for forty-five (45) days after Bid Opening.
 - b. To accept the provisions of the Instructions to Bidders.
 - c. To enter into and execute a Contract within ten (10) days of the Notice of Award issue date, and to simultaneously furnish Performance and Labor and Material Bonds.
 - d. To commence the Work immediately upon receipt of Notice of Award.
4. The Undersigned agrees that the Work proposed herein will be Substantially Complete the dates indicated in specification Section 011020 - "Milestone Schedule".
5. By submission of this Bid, each Bidder and each person signing on behalf of any Bidder certifies, and in the case of a joint Bid, each party thereto certifies as to its own organization, under penalty of perjury, that to the best of the party's knowledge and belief:
 - a. the prices in this Bid have been arrived at independently without collusion, consultation, communication or agreement, for the purpose of restricting competition, as to any matter relating to such prices, with any other Bidder or with any competitor,
 - b. unless otherwise required by law, the prices that have been quoted in this Bid have not been knowingly disclosed by the Bidder, and will not knowingly be disclosed by

(Name of Bidder)

- the Bidder prior to opening, directly or indirectly, to any other Bidder or to any competitor; and
- c. no attempt has been made or will be made by the Bidder to induce any other person, partnership or corporation to submit or not to submit a Bid for the purpose of restricting competition.

A Bid shall not be considered for award, nor shall any award be made where a., b., and c. above have not been complied with, provided however, that if in any case the Bidder cannot make the foregoing certification, the Bidder shall so state and shall furnish, with the Bid, a signed statement which sets forth in detail the reasons therefor. Where a., b., and c. above have not been complied with, the Bid shall not be considered for award, nor shall any award be made unless the head of the purchasing unit of the political subdivision, public department, agency or official thereof to which the Bid is made, or his designee, determines that such disclosure was not made for the purpose of restricting competition.

The fact that a Bidder (a) has published price lists, rates or tariffs covering items being procured, (b) has informed prospective customers of proposed or pending publication of new or revised price lists for such items, or (c) has sold the same items to other customers at the same prices being Bid, does not constitute, without more, a disclosure within the meaning of this Section.

6. The Undersigned understands that the Owner reserves the right to accept or reject any or all Bids and to waive any informalities in the bidding.
7. The Undersigned acknowledges the receipt of the following addenda, but agrees that it is bound by all addenda whether or not listed herein:

<u>Addendum Number</u>	<u>Date of Addendum</u>
_____	_____
_____	_____
_____	_____

8. **TOTAL BASE BID**

All labor, material, services and equipment necessary for completion of the Work shown on the Drawings and the Technical Specifications for General Construction Work:

\$ _____ (In numbers)

_____ Dollars
(in words)

9. **ALTERNATES**

The Undersigned agrees to provide all work in accordance with the requirements of the Specifications and the Drawings and includes all costs of related coordination, modification, or adjustment for the following:

(Name of Bidder)

ALTERNATE NO. 1: GYMNASIUM BASEMENT FIT-OUT

ADD _____ Dollars (\$ _____)

ALTERNATE NO. 2: EXTERIOR SUNSHADES

ADD _____ Dollars (\$ _____)

ALTERNATE NO. 3: SOLAR PANELS

ADD _____ Dollars (\$ _____)

ALTERNATE NO. 4: VEGETATED ROOFS

ADD _____ Dollars (\$ _____)

ALTERNATE NO. 5: Not applicable.

ALTERNATE NO. 6: CASEWORK/MILLWORK/GYM EQUIPMENT

ADD _____ Dollars (\$ _____)

ALTERNATE NO. 7: EXTERIOR SIDEWALK AROUND CHURCH

ADD _____ Dollars (\$ _____)

10. **UNIT PRICES** - none

11. **ALLOWANCES**

The Undersigned has included the specified allowances in the Total Base Bid quoted.

12. The Undersigned has attached the following documents to this Bid:

- a. Bid Breakdown Schedule of Values - Contract No. 1 - General Construction Work
- b. Certificate of Compliance with the Iran Divestment Act
- c. Certificate of Compliance with the MacBride Principles
- d. Yonkers Joint Schools Construction Board Bid Package Diversification Documents
- e. City of Yonkers Vendor Background Questionnaire
- f. Statement of Contractor's Apprenticeship Program Compliance
- g. Bid Security

(Name of Bidder)

- h. Statement of Bidder's Qualifications AIA Document A305, including Exhibits A, B, C, D and E.
- i. City of Yonkers Bidder's Affidavit

Legal name of person, partnership, joint venture, limited liability company, or corporation (please type)

(If corporation, affix corporate seal)

Address (please type)

Federal ID No. or Social Security No. (please type)

Phone No. (please type)

FAX No. (please type)

Name and title of signer (please type)

Signature

Date

If a Corporation
Name

Address

_____, PRESIDENT _____

_____, SECRETARY _____

_____, TREASURER _____

If a Partnership
Name of Partners

Address

If a Joint Venture
Name of Members

Address

If an Individual
Name of Individual

Address

(Name of Bidder)

If a Limited Liability Company (LLC)
Name of Members

Address

The following additions, substitutions, or clarifications are extracted from the (5) Bid Addenda issued with this project during bidding. This insert is intended to summarize addendum information relevant to this specification section. See Bid Addenda issued by the City of Yonkers for complete contract document changes.

Bid Addendum No. 2:

Contract No. 1 – General Construction Work: Replace the section issued with the bid documents with the one attached to this addendum.

BID BREAKDOWN SCHEDULE OF VALUES (SOV)
FOR CONTRACT 1 – GENERAL CONSTRUCTION WORK
YJSCB NEW COMMUNITY SCHOOL 35 AT THE ST. DENIS SCHOOL SITE
REISSUED IN ADDENDUM NO 2

SUBMITTED FOR: Contract 1 - General Construction Work

SUBMITTED BY: Company: _____
Address: _____

Phone: _____
Fax No.: _____
Contact Name: _____
Email Address: _____

TO: Yonkers Joint School Construction Board
City Hall, 40 South Broadway
Yonkers, NY 10701

Pursuant to and in accordance with the invitation for proposals for the New Community School 35 at the St. Denis School Site, and having familiarized myself with the conditions of the site, the drawings and specifications (including Instructions to Bidders, Form of Bid Bond, Form of Contract, the General Conditions and the Technical Specifications) as prepared by KG+D Architects, P.C. and their associated consultants, dated November 1, 2021 and addenda, if any, hereby propose to furnish all labor, material, equipment, and services required to construct and complete the work as follows:

1. SUMMARY for Contract No. 1 – General Construction Base Bid and Total Base Bid

All labor and materials necessary for the General Construction Work for the YJSCB New Community School 35 at the ST. DENIS SCHOOL SITE, as shown on the Bid Documents, including drawings and the specifications, as follows:

Base Bid Amount: _____ Dollars (\$ _____)

PLUS

Allowance Amount: One Hundred Thousand Dollars and No Cents (\$100,000.00)

EQUALS

Total Base Bid Amount: _____ Dollars (\$ _____)

2. BID BREAKDOWN for Contract No. 1 – General Construction Base Bid and Total Base Bid

Schedule of Values Base Bid

- 1. Bonds and Insurance _____
- 2. General Conditions _____
- 3. Temporary Provisions _____
- 4. Site Protection & Erosion Controls _____
- 5. Earthwork, Excavation & Backfill _____
- 6. Utility Trenching and Backfill _____
- 7. Asphalt & Asphalt Base _____
- 8. Site Concrete _____
- 9. Concrete Retaining Wall & Ramps _____
- 10. Storm/Sanitary/Sewer _____
- 11. Fire Service Water Line _____
- 12. Site Furnishings & Equipment _____
- 13. Steel Fence & Railings _____
- 14. Chain Link Fence _____
- 15. Landscaping/Topsoil/Seeding/Plants _____
- 16. Pavement Striping _____
- 17. Building Concrete _____
- 18. Building Masonry _____
- 19. Structural Steel & Deck _____
- 20. Metal Stairs _____
- 21. Interior Doors & Hardware _____
- 22. Exterior Doors & Hardware _____
- 23. Railings and Handrails _____
- 24. Rough and Finish Carpentry _____
- 25. Architectural Woodwork _____
- 26. Waterproofing and Damp Proofing _____
- 27. Building Insulation _____
- 28. Roofing and Accessories _____
- 29. Firestopping and Sealants _____
- 30. Plaster Work _____
- 31. Doors, Frames & Hardware _____
- 32. Aluminum Windows, Doors & Frames _____
- 33. Glass, Glazing and Mirrors _____
- 34. Fixed Louvers _____
- 35. Gypsum Board _____
- 36. Porcelain Tile _____
- 37. Acoustical Ceilings _____
- 38. Flooring/Tile/Carpet _____
- 39. Gymnasium Flooring _____
- 40. Applied Fireproofing _____
- 41. Expansion Control _____
- 42. Terrazzo _____
- 43. Painting _____
- 44. Display Surfaces _____
- 45. Toilet Partitions & Accessories _____

46. Metal Lockers	_____
47. Fire Extinguishers & Cabinets	_____
48. Miscellaneous Specialties	_____
49. Kitchen Equipment	_____
50. Gymnasium Equipment	_____
51. Clean Up	_____
52. Close Out/As-Builts/Punchlist	_____
53. Others (specify)	_____
_____	_____
_____	_____
_____	_____

Total (must equal Base Bid price) _____

PLUS

Allowance amount _____ \$100,000.00 _____

EQUALS

Total Base Bid (must equal Base Bid plus Allowance) _____

Respectfully submitted,

Dated _____

By

Name of Firm

Signature

Printed/Typed Name

Title

13 January 2022
Conformed Specifications
SED #66-23-00-01-0-346-001

Yonkers Joint Schools Construction Board
Community School 35

The following additions, substitutions, or clarifications are extracted from the (5) Bid Addenda issued with this project during bidding. This insert is intended to summarize addendum information relevant to this specification section. See Bid Addenda issued by the City of Yonkers for complete contract document changes.

Bid Addendum No. 1:

Contract No. 2 – Plumbing and Fire Protection Work: On page 3 add the following to become 12.i” - “i. City of Yonkers Bidder’s Affidavit”

BID FORM
FOR
COMMUNITY SCHOOL 35
CONTRACT NO. 2 - PLUMBING AND FIRE PROTECTION WORK

Yonkers Joint Schools Construction Board
City Hall
40 South Broadway
Yonkers, NY 10701
Attention: Marlyn Anderson, Secretary

(Deliver Bids To: Yonkers Bureau of Purchasing, One Larkin Center, 3rd Floor, Yonkers, N.Y. 10701)

1. The Undersigned hereby declares that it has carefully examined all Bidding and Contract Documents and has inspected the actual location of Work, together with the local sources of supply, and has satisfied itself as to all quantities and conditions, and understands that in signing this Proposal, it waives all rights to plead any misunderstanding regarding the same.
2. The Undersigned further understands and agrees that it is to do, perform and complete all the Work in accordance with the Contract Documents and Contract and to accept in full compensation therefor, the amount of the Base Bid, modified by such additive or deductive alternatives, if any, as are accepted by the Owner.
3. In submitting this Bid, the Undersigned agrees:
 - a. To hold the Bid open for forty-five (45) days after Bid Opening.
 - b. To accept the provisions of the Instructions to Bidders.
 - c. To enter into and execute a Contract within ten (10) days of the Notice of Award issue date, and to simultaneously furnish Performance and Labor and Material Bonds.
 - d. To commence the Work immediately upon receipt of Notice of Award.
4. The Undersigned agrees that the Work proposed herein will be Substantially Complete the dates indicated in specification Section 011020 - "Milestone Schedule".
5. By submission of this Bid, each Bidder and each person signing on behalf of any Bidder certifies, and in the case of a joint Bid, each party thereto certifies as to its own organization, under penalty of perjury, that to the best of the party's knowledge and belief:
 - a. the prices in this Bid have been arrived at independently without collusion, consultation, communication or agreement, for the purpose of restricting competition, as to any matter relating to such prices, with any other Bidder or with any competitor,
 - b. unless otherwise required by law, the prices that have been quoted in this Bid have not been knowingly disclosed by the Bidder, and will not knowingly be disclosed by

(Name of Bidder)

- the Bidder prior to opening, directly or indirectly, to any other Bidder or to any competitor; and
- c. no attempt has been made or will be made by the Bidder to induce any other person, partnership or corporation to submit or not to submit a Bid for the purpose of restricting competition.

A Bid shall not be considered for award, nor shall any award be made where a., b., and c. above have not been complied with, provided however, that if in any case the Bidder cannot make the foregoing certification, the Bidder shall so state and shall furnish, with the Bid, a signed statement which sets forth in detail the reasons therefor. Where a., b., and c. above have not been complied with, the Bid shall not be considered for award, nor shall any award be made unless the head of the purchasing unit of the political subdivision, public department, agency or official thereof to which the Bid is made, or his designee, determines that such disclosure was not made for the purpose of restricting competition.

The fact that a Bidder (a) has published price lists, rates or tariffs covering items being procured, (b) has informed prospective customers of proposed or pending publication of new or revised price lists for such items, or (c) has sold the same items to other customers at the same prices being Bid, does not constitute, without more, a disclosure within the meaning of this Section.

6. The Undersigned understands that the Owner reserves the right to accept or reject any or all Bids and to waive any informalities in the bidding.
7. The Undersigned acknowledges the receipt of the following addenda, but agrees that it is bound by all addenda whether or not listed herein:

<u>Addendum Number</u>	<u>Date of Addendum</u>
_____	_____
_____	_____
_____	_____

8. **BASE BID**

All labor, material, services and equipment necessary for completion of the Work shown on the Drawings and the Technical Specifications for Plumbing and Fire Protection Work:

\$ _____ (In numbers)

_____ Dollars
(in words)

9. **ALTERNATES**

The Undersigned agrees to provide all work in accordance with the requirements of the Specifications and the Drawings and includes all costs of related coordination, modification, or adjustment for the following:

(Name of Bidder)

ALTERNATE NO. 1: GYMNASIUM BASEMENT FIT-OUT

ADD _____ Dollars (\$ _____)

ALTERNATE NO. 2: Not applicable.
ALTERNATE NO. 3: Not applicable.
ALTERNATE NO. 4: Not applicable.
ALTERNATE NO. 5: Not applicable.
ALTERNATE NO. 6: Not applicable.
ALTERNATE NO. 7: Not applicable

10. **UNIT PRICES** - none

11. **ALLOWANCES** - none

12. The Undersigned has attached the following documents to this Bid:

- a. Bid Breakdown Schedule of Values - Contract No. 2 - Plumbing and Fire Protection Work
- b. Certificate of Compliance with the Iran Divestment Act
- c. Certificate of Compliance with the MacBride Principles
- d. Yonkers Joint Schools Construction Board Bid Package Diversification Documents
- e. City of Yonkers Vendor Background Questionnaire
- f. Statement of Contractor's Apprenticeship Program Compliance
- g. Bid Security.
- h. Statement of Bidder's Qualifications AIA Document A305, including Exhibits A, B, C, D and E.

Legal name of person, partnership, joint venture, limited liability company or corporation (please type)

(If corporation, affix
corporate seal)

Address (please type)

Federal ID No. or Social Security No. (please type)

Phone No. (please type)

FAX No. (please type)

Name and title of signer (please type)

Signature

Date

(Name of Bidder)

If a Corporation
Name

Address

_____, PRESIDENT _____
_____, SECRETARY _____
_____, TREASURER _____

If a Partnership
Name of Partners

Address

If a Joint Venture
Name of Members

Address

If an Individual
Name of Individual

Address

If a Limited Liability Company (LLC)
Name of Members

Address

BID BREAKDOWN SCHEDULE OF VALUES (SOV)
FOR CONTRACT 2 – PLUMBING AND FIRE PROTECTION WORK
YJSCB NEW COMMUNITY SCHOOL 35 AT THE ST. DENIS SCHOOL SITE

SUBMITTED FOR: Contract 2 – Plumbing and Fire Protection Work

SUBMITTED BY: Company: _____

Address: _____

Phone: _____

Fax No.: _____

Contact Name: _____

Email Address: _____

TO: Yonkers Joint School Construction Board
City Hall, 40 South Broadway
Yonkers, NY 10701

Pursuant to and in accordance with the invitation for proposals for the New Community School 35 at the St. Denis School Site, and having familiarized myself with the conditions of the site, the drawings and specifications (including Instructions to Bidders, Form of Bid Bond, Form of Contract, the General Conditions and the Technical Specifications) as prepared by KG+D Architects, P.C. and their associated consultants, dated November 1, 2021 and addenda, if any, hereby propose to furnish all labor, material, equipment, and services required to construct and complete the work as follows:

1a. Contract No. 2 – Plumbing and Fire Protection Work Base Bid

Submit the price for all labor and materials necessary for the Base Bid Plumbing and Fire Protection Work YJSCB New Community School 35 at the ST. DENIS SCHOOL SITE as shown on the Bid Documents, including drawings and the specifications.

The sum of _____

Dollars (\$_____).

Schedule of Values Base Bid

- | | |
|-------------------------------------|-------|
| 1. Bonds and Insurance | _____ |
| 2. General Conditions | _____ |
| 3. Selective Demolition | _____ |
| 4. Trenching & Backfill at Sanitary | _____ |
| 5. Access Doors | _____ |
| 6. Fire Stopping/Joint Sealers | _____ |
| 7. Domestic Water Supply System | _____ |

8. Gas Connections & Associated Work	_____
9. Plumbing Fixtures and Equipment	_____
10. Water Piping	_____
11. Sanitary Piping	_____
12. Storm Piping including Roof Drains	_____
13. Grease Interceptors	_____
14. Engineering & DOH Filing - Backflow Preventers	_____
15. Supports, Sleeves, And Plates	_____
16. Kitchen Equipment Hookup	_____
17. Insulation and Coverings	_____
18. Fire Sprinkler System	_____
19. Fire Pump for Sprinkler System	_____
20. Test and Adjustments	_____
21. Tags, Charts, and Identification	_____
22. Start Up and Commissioning	_____
23. Closeout/As Builts/Punchlist	_____
24. Clean Up	_____
25. Others (specify)	_____
_____	_____
_____	_____
_____	_____
_____	_____
Total (must equal base bid price)	_____

Respectfully submitted,

Dated _____

By

Name of Firm

Signature

Printed/Typed Name

Title

The following additions, substitutions, or clarifications are extracted from the (5) Bid Addenda issued with this project during bidding. This insert is intended to summarize addendum information relevant to this specification section. See Bid Addenda issued by the City of Yonkers for complete contract document changes.

Bid Addendum No. 1:

Contract No. 3 – HVAC Work: On page 3 add the following to become 12.i” - “i. City of Yonkers Bidder’s Affidavit”

BID FORM
FOR
COMMUNITY SCHOOL 35
CONTRACT NO. 3 - HVAC WORK

Yonkers Joint Schools Construction Board
City Hall
40 South Broadway
Yonkers, NY 10701
Attention: Marlyn Anderson, Secretary

(Deliver Bids To: Yonkers Bureau of Purchasing, One Larkin Center, 3rd Floor, Yonkers, N.Y. 10701)

1. The Undersigned hereby declares that it has carefully examined all Bidding and Contract Documents and has inspected the actual location of Work, together with the local sources of supply, and has satisfied itself as to all quantities and conditions, and understands that in signing this Proposal, it waives all rights to plead any misunderstanding regarding the same.
2. The Undersigned further understands and agrees that it is to do, perform and complete all the Work in accordance with the Contract Documents and Contract and to accept in full compensation therefor, the amount of the Base Bid, modified by such additive or deductive alternatives, if any, as are accepted by the Owner.
3. In submitting this Bid, the Undersigned agrees:
 - a. To hold the Bid open for forty-five (45) days after Bid Opening.
 - b. To accept the provisions of the Instructions to Bidders.
 - c. To enter into and execute a Contract within ten (10) days of the Notice of Award issue date, and to simultaneously furnish Performance and Labor and Material Bonds.
 - d. To commence the Work immediately upon receipt of Notice of Award.
4. The Undersigned agrees that the Work proposed herein will be Substantially Complete the dates indicated in specification Section 011020 - "Milestone Schedule".
5. By submission of this Bid, each Bidder and each person signing on behalf of any Bidder certifies, and in the case of a joint Bid, each party thereto certifies as to its own organization, under penalty of perjury, that to the best of the party's knowledge and belief:
 - a. the prices in this Bid have been arrived at independently without collusion, consultation, communication or agreement, for the purpose of restricting competition, as to any matter relating to such prices, with any other Bidder or with any competitor,
 - b. unless otherwise required by law, the prices that have been quoted in this Bid have not been knowingly disclosed by the Bidder, and will not knowingly be disclosed by

(Name of Bidder)

- the Bidder prior to opening, directly or indirectly, to any other Bidder or to any competitor; and
- c. no attempt has been made or will be made by the Bidder to induce any other person, partnership or corporation to submit or not to submit a Bid for the purpose of restricting competition.

A Bid shall not be considered for award, nor shall any award be made where a., b., and c. above have not been complied with, provided however, that if in any case the Bidder cannot make the foregoing certification, the Bidder shall so state and shall furnish, with the Bid, a signed statement which sets forth in detail the reasons therefor. Where a., b., and c. above have not been complied with, the Bid shall not be considered for award, nor shall any award be made unless the head of the purchasing unit of the political subdivision, public department, agency or official thereof to which the Bid is made, or his designee, determines that such disclosure was not made for the purpose of restricting competition.

The fact that a Bidder (a) has published price lists, rates or tariffs covering items being procured, (b) has informed prospective customers of proposed or pending publication of new or revised price lists for such items, or (c) has sold the same items to other customers at the same prices being Bid, does not constitute, without more, a disclosure within the meaning of this Section.

6. The Undersigned understands that the Owner reserves the right to accept or reject any or all Bids and to waive any informalities in the bidding.
7. The Undersigned acknowledges the receipt of the following addenda, but agrees that it is bound by all addenda whether or not listed herein:

<u>Addendum Number</u>	<u>Date of Addendum</u>
_____	_____
_____	_____
_____	_____

8. **BASE BID**

All labor, material, services and equipment necessary for completion of the Work shown on the Drawings and the Technical Specifications for HVAC Work:

\$ _____ (In numbers)

_____ Dollars
(in words)

9. **ALTERNATES**

The Undersigned agrees to provide all work in accordance with the requirements of the Specifications and the Drawings and includes all costs of related coordination, modification, or adjustment for the following:

(Name of Bidder)

ALTERNATE NO. 1: GYMNASIUM BASEMENT FIT-OUT

ADD _____ Dollars (\$ _____)

ALTERNATE NO. 2: Not applicable.
ALTERNATE NO. 3: Not applicable.
ALTERNATE NO. 4: Not applicable.
ALTERNATE NO. 5: Not applicable.
ALTERNATE NO. 6: Not applicable.
ALTERNATE NO. 7: Not applicable

10. **UNIT PRICES** - none

11. **ALLOWANCES** - none

12. The Undersigned has attached the following documents to this Bid:

- a. Bid Breakdown Schedule of Values - Contract No. 3 - HVAC Work
- b. Certificate of Compliance with the Iran Divestment Act
- c. Certificate of Compliance with the MacBride Principles
- d. Yonkers Joint Schools Construction Board Bid Package Diversification Documents
- e. City of Yonkers Vendor Background Questionnaire
- f. Statement of Contractor's Apprenticeship Program Compliance
- g. Bid Security.
- h. Statement of Bidder's Qualifications AIA Document A305, including Exhibits A, B, C, D and E.

Legal name of person, partnership, joint venture, limited liability
company or corporation (please type)

(If corporation, affix
corporate seal)

Address (please type)

Federal ID No. or Social Security No. (please type)

Phone No. (please type)

FAX No. (please type)

Name and title of signer (please type)

Signature

Date

(Name of Bidder)

If a Corporation
Name

Address

_____, PRESIDENT _____
_____, SECRETARY _____
_____, TREASURER _____

If a Partnership
Name of Partners

Address

If a Joint Venture

Name of Members

Address

If an Individual
Name of Individual

Address

If a Limited Liability Company (LLC)
Name of Members

Address

BID BREAKDOWN SCHEDULE OF VALUES (SOV)
FOR CONTRACT 3 – HVAC WORK
YJSCB NEW COMMUNITY SCHOOL 35 AT THE ST. DENIS SCHOOL SITE

SUBMITTED FOR: Contract 3 –HVAC Work

SUBMITTED BY: Company: _____

Address: _____

Phone: _____

Fax No.: _____

Contact Name: _____

Email Address: _____

TO: Yonkers Joint School Construction Board
City Hall, 40 South Broadway
Yonkers, NY 10701

Pursuant to and in accordance with the invitation for proposals for the New Community School 35 at the St. Denis School Site, and having familiarized myself with the conditions of the site, the drawings and specifications (including Instructions to Bidders, Form of Bid Bond, Form of Contract, the General Conditions and the Technical Specifications) as prepared by KG+D Architects, P.C. and their associated consultants, dated November 1, 2021 and addenda, if any, hereby propose to furnish all labor, material, equipment, and services required to construct and complete the work as follows:

1a. Contract No. 3 – HVAC Work Base Bid

Submit the price for all labor and materials necessary for the Base Bid HVAC Work YJSCB New Community School 35 at the ST. DENIS SCHOOL SITE as shown on the Bid Documents, including drawings and the specifications.

The sum of _____

Dollars (\$_____).

Schedule of Values Base Bid

- | | |
|--------------------------------|-------|
| 1. Bonds & Insurance | _____ |
| 2. General Conditions | _____ |
| 3. Access Doors | _____ |
| 4. Diesel Engine Exhaust | _____ |
| 5. Fire Stopping/Joint Sealers | _____ |
| 6. Diesel Fuel System | _____ |
| 7. Piping, Fittings and Valves | _____ |

8. Heat Recovery VRF Systems	_____
9. Ductless Split System	_____
10. Energy Recovery Units	_____
11. Fans	_____
12. Kitchen Exhaust	_____
13. Hydronic Specialties	_____
14. Pumps	_____
15. Hot Water Units	_____
16. Fin Tube Radiation	_____
17. Sheet Metal Work and Accessories	_____
18. Energy Recovery Units	_____
19. Insulation and Coverings	_____
20. Dampers, Louvers and Miscellaneous	_____
21. Temperature Controls	_____
22. Labeling & Charts	_____
23. Start Up and Commissioning	_____
24. Close Out/As Builts/Punchlist	_____
25. Clean Up	_____
26. Others (specify)	_____
_____	_____
_____	_____
_____	_____
Total (must equal base bid price)	_____

Respectfully submitted,

Dated _____

By

Name of Firm

Signature

Printed/Typed Name

Title

The following additions, substitutions, or clarifications are extracted from the (5) Bid Addenda issued with this project during bidding. This insert is intended to summarize addendum information relevant to this specification section. See Bid Addenda issued by the City of Yonkers for complete contract document changes.

Bid Addendum No. 1:

Contract No. 4 – Electrical Work: On page 3 add the following to become 12.i” - “i. City of Yonkers Bidder’s Affidavit”

BID FORM
FOR
COMMUNITY SCHOOL 35
CONTRACT NO. 4 - ELECTRICAL WORK

Yonkers Joint Schools Construction Board
City Hall
40 South Broadway
Yonkers, NY 10701
Attention: Marlyn Anderson, Secretary

(Deliver Bids To: Yonkers Bureau of Purchasing, One Larkin Center, 3rd Floor, Yonkers, N.Y. 10701)

1. The Undersigned hereby declares that it has carefully examined all Bidding and Contract Documents and has inspected the actual location of Work, together with the local sources of supply, and has satisfied itself as to all quantities and conditions, and understands that in signing this Proposal, it waives all rights to plead any misunderstanding regarding the same.
2. The Undersigned further understands and agrees that it is to do, perform and complete all the Work in accordance with the Contract Documents and Contract and to accept in full compensation therefor, the amount of the Base Bid, modified by such additive or deductive alternatives, if any, as are accepted by the Owner.
3. In submitting this Bid, the Undersigned agrees:
 - a. To hold the Bid open for forty-five (45) days after Bid Opening.
 - b. To accept the provisions of the Instructions to Bidders.
 - c. To enter into and execute a Contract within ten (10) days of the Notice of Award issue date, and to simultaneously furnish Performance and Labor and Material Bonds.
 - d. To commence the Work immediately upon receipt of Notice of Award.
4. The Undersigned agrees that the Work proposed herein will be Substantially Complete the dates indicated in specification Section 011020 - "Milestone Schedule".
5. By submission of this Bid, each Bidder and each person signing on behalf of any Bidder certifies, and in the case of a joint Bid, each party thereto certifies as to its own organization, under penalty of perjury, that to the best of the party's knowledge and belief:
 - a. the prices in this Bid have been arrived at independently without collusion, consultation, communication or agreement, for the purpose of restricting competition, as to any matter relating to such prices, with any other Bidder or with any competitor,
 - b. unless otherwise required by law, the prices that have been quoted in this Bid have not been knowingly disclosed by the Bidder, and will not knowingly be disclosed by

(Name of Bidder)

- the Bidder prior to opening, directly or indirectly, to any other Bidder or to any competitor; and
- c. no attempt has been made or will be made by the Bidder to induce any other person, partnership or corporation to submit or not to submit a Bid for the purpose of restricting competition.

A Bid shall not be considered for award, nor shall any award be made where a., b., and c. above have not been complied with, provided however, that if in any case the Bidder cannot make the foregoing certification, the Bidder shall so state and shall furnish, with the Bid, a signed statement which sets forth in detail the reasons therefor. Where a., b., and c. above have not been complied with, the Bid shall not be considered for award, nor shall any award be made unless the head of the purchasing unit of the political subdivision, public department, agency or official thereof to which the Bid is made, or his designee, determines that such disclosure was not made for the purpose of restricting competition.

The fact that a Bidder (a) has published price lists, rates or tariffs covering items being procured, (b) has informed prospective customers of proposed or pending publication of new or revised price lists for such items, or (c) has sold the same items to other customers at the same prices being Bid, does not constitute, without more, a disclosure within the meaning of this Section.

6. The Undersigned understands that the Owner reserves the right to accept or reject any or all Bids and to waive any informalities in the bidding.
7. The Undersigned acknowledges the receipt of the following addenda, but agrees that it is bound by all addenda whether or not listed herein:

<u>Addendum Number</u>	<u>Date of Addendum</u>
_____	_____
_____	_____
_____	_____

8. **BASE BID**

All labor, material, services and equipment necessary for completion of the Work shown on the Drawings and the Technical Specifications for Electrical Work:

\$ _____ (In numbers)

_____ Dollars
(in words)

9. **ALTERNATES**

The Undersigned agrees to provide all work in accordance with the requirements of the Specifications and the Drawings and includes all costs of related coordination, modification, or adjustment for the following:

(Name of Bidder)

ALTERNATE NO. 1: GYMNASIUM BASEMENT FIT-OUT

ADD _____ Dollars (\$ _____)

ALTERNATE NO. 2: Not applicable

ALTERNATE NO. 3: SOLAR PANELS

ADD _____ Dollars (\$ _____)

ALTERNATE NO. 4: Not applicable

ALTERNATE NO. 5: STAGE ELECTRICAL EQUIPMENT

ADD _____ Dollars (\$ _____)

ALTERNATE NO. 6: Not applicable

ALTERNATE NO. 7: Not applicable

10. **UNIT PRICES** - none

11. **ALLOWANCES** - none

12. The Undersigned has attached the following documents to this Bid:

- a. Bid Breakdown Schedule of Values - Contract No. 4 - Electrical Work
- b. Certificate of Compliance with the Iran Divestment Act
- c. Certificate of Compliance with the MacBride Principles
- d. Yonkers Joint Schools Construction Board Bid Package Diversification Documents
- e. City of Yonkers Vendor Background Questionnaire
- f. Statement of Contractor's Apprenticeship Program Compliance
- g. Bid Security
- h. Statement of Bidder's Qualifications AIA Document A305, including Exhibits A, B, C, D and E.

Legal name of person, partnership, joint venture, limited liability
company or corporation (please type)

(If corporation, affix
corporate seal)

Address (please type)

Federal ID No. or Social Security No. (please type)

Phone No. (please type)

(Name of Bidder)

FAX No. (please type) _____

Name and title of signer (please type) _____

Signature _____ Date _____

If a Corporation
Name

Address

_____, PRESIDENT _____

_____, SECRETARY _____

_____, TREASURER _____

If a Partnership
Name of Partners

Address

If a Joint Venture
Name of Members

Address

If an Individual
Name of Individual

Address

If a Limited Liability Company (LLC)
Name of Members

Address

BID BREAKDOWN SCHEDULE OF VALUES (SOV)
FOR CONTRACT 4 – ELECTRICAL WORK
YJSCB NEW COMMUNITY SCHOOL 35 AT THE ST. DENIS SCHOOL SITE

SUBMITTED FOR: Contract 4 –Electrical Work

SUBMITTED BY: Company: _____

Address: _____

Phone: _____

Fax No.: _____

Contact Name: _____

Email Address: _____

TO: Yonkers Joint School Construction Board
City Hall, 40 South Broadway
Yonkers, NY 10701

Pursuant to and in accordance with the invitation for proposals for the New Community School 35 at the St. Denis School Site, and having familiarized myself with the conditions of the site, the drawings and specifications (including Instructions to Bidders, Form of Bid Bond, Form of Contract, the General Conditions and the Technical Specifications) as prepared by KG+D Architects, P.C. and their associated consultants, dated November 1, 2021 and addenda, if any, hereby propose to furnish all labor, material, equipment, and services required to construct and complete the work as follows:

1a. Contract No. 4 – Electrical Work Base Bid

Submit the price for all labor and materials necessary for the Base Bid Electrical Work YJSCB New Community School 35 at the ST. DENIS SCHOOL SITE as shown on the Bid Documents, including drawings and the specifications.

The sum of _____

Dollars (\$_____).

Schedule of Values Base Bid

- | | |
|-----------------------------------|-------|
| 1. Bonds and Insurance | _____ |
| 2. General Conditions | _____ |
| 3. Temporary Provisions | _____ |
| 4. Access Doors | _____ |
| 5. Conduit | _____ |
| 6. Wire and Cable | _____ |
| 7. Overcurrent Protective Devices | _____ |

8. Boxes/Wiring Devices	_____
9. Lighting Controls	_____
10. Cabinets, Enclosures and Supporting Devices	_____
11. Distribution Switchboard and Panel Boards	_____
12. Electric Service	_____
13. General Labeling and Identification	_____
14. Interior Luminaires	_____
15. Disconnect Switches and Grounding	_____
16. Emergency Generator	_____
17. Fire Alarm System	_____
18. Gymnasium Sound System	_____
19. Start Up and Testing	_____
20. Closeout/As Builts/Punchlist	_____
21. Clean Up	_____
22. Others (specify)	_____
_____	_____
_____	_____
_____	_____
_____	_____
Total (must equal base bid price)	_____

Respectfully submitted,

Dated _____

By

Name of Firm

Signature

Printed/Typed Name

Title

CERTIFICATION OF COMPLIANCE WITH THE IRAN DIVESTMENT ACT

As a result of the Iran Divestment Act of 2012 (the "Act"), Chapter 1 of the 2012 Laws of New York, a new provision has been added to State Finance Law (SFL) § 165-a and New York General Municipal Law § 103-g, both effective April 12, 2012. Under the Act, the Commissioner of the Office of General Services (OGS) will be developing a list of "persons" who are engaged in "investment activities in Iran" (both are defined terms in the law) (the "Prohibited Entities List"). Pursuant to SFL § 165-a(3)(b), the initial list is expected to be issued no later than 120 days after the Act's effective date at which time it will be posted on the OGS website.

By submitting a bid in response to this solicitation or by assuming the responsibility of a Contract awarded hereunder, each Bidder/Contractor, any person signing on behalf of any Bidder/Contractor and any assignee or subcontractor and, in the case of a joint bid, each party thereto, certifies, under penalty of perjury, that once the Prohibited Entities List is posted on the OGS website, that to the best of its knowledge and belief, that each Bidder/Contractor and any subcontractor or assignee is not identified on the Prohibited Entities List created pursuant to SFL § 165-a(3)(b).

Additionally, Bidder/Contractor is advised that once the Prohibited Entities List is posted on the OGS Website, any Bidder/Contractor seeking to renew or extend a Contract or assume the responsibility of a Contract awarded in response to this solicitation must certify at the time the Contract is renewed, extended or assigned that it is not included on the Prohibited Entities List.

During the term of the Contract, should the School District receive information that a Bidder/Contractor is in violation of the above-referenced certification, the School District will offer the person or entity an opportunity to respond. If the person or entity fails to demonstrate that he/she/it has ceased engagement in the investment which is in violation of the Act within 90 days after the determination of such violation, then the School District shall take such action as may be appropriate including, but not limited to, imposing sanctions, seeking compliance, recovering damages or declaring the Bidder/Contractor in default. The School District reserves the right to reject any bid or request for assignment for a Bidder/Contractor that appears on the Prohibited Entities List prior to the award of a contract and to pursue a responsibility review with respect to any Bidder/Contractor that is awarded a contract and subsequently appears on the Prohibited Entities List.

I, _____, being duly sworn, deposes and says that he/she is the _____ of the _____ Corporation and that neither the Bidder/ Contractor nor any proposed subcontractor is identified on the Prohibited Entities List.

SIGNED: _____

SWORN to before me this _____ day of _____ 202_____

Notary Public: _____

OR

DECLARATION OF BIDDER'S INABILITY TO PROVIDE CERTIFICATION OF COMPLIANCE
WITH THE IRAN DIVESTMENT ACT

Bidders shall complete this form if they cannot certify that the bidder /contractor or any proposed subcontractor is not identified on the Prohibited Entities List. The District reserves the right to undertake any investigation into the information provided herein or to request additional information from the bidder.

Name of the Bidder: _____

Address of Bidder _____

Has bidder been involved in investment activities in Iran? _____

Describe the type of activities including but not limited to the amounts and the nature of the investments (e.g. banking, energy, real estate): _____

If so, when did the first investment activity occur? _____

Have the investment activities ended? _____

If so, what was the date of the last investment activity? _____

If not, have the investment activities increased or expanded since April 12, 2012? _____

Has the bidder adopted, publicized, or implemented a formal plan to cease the investment activities in Iran and to refrain from engaging in any new investments in Iran? _____

If so, provide the date of the adoption of the plan by the bidder and proof of the adopted resolution, if any and a copy of the formal plan. _____

In detail, state the reasons why the bidder cannot provide the Certification of Compliance with the Iran Divestment Act below (additional pages may be attached): _____

I, _____ being duly sworn, deposes and says that he/she is the

_____ of the _____ Corporation and
the foregoing is true and accurate.

SIGNED

SWORN to before me this _____ day of _____ 202_____

Notary Public: _____

**CERTIFICATE OF COMPLIANCE WITH THE MACBRIDE PRINCIPLES
(CERTIFICATION REGARDING BUSINESS DEALINGS WITH NORTHERN IRELAND)**

- A. The Contractor and any individual or legal entity in which the Contractor holds a ten percent (10%) or greater ownership interest and any individual or legal entity that holds a ten percent (10%) or greater ownership interest in the Contractor (a) has no business operations in Northern Ireland, or (b) shall take lawful steps in good faith to conduct any business operations in Northern Ireland in accordance with the MacBride Principles.
- B. For purposes of this Certification, “MacBride Principles” shall mean those principles relating to nondiscrimination in employment and freedom of workplace opportunity which require employers doing business in Northern Ireland to:
- (1) increase the representation of individuals from underrepresented religious groups in the work force, including managerial, supervisory, administrative, clerical and technical jobs;
 - (2) take steps to promote adequate security for the protection of employees from underrepresented religious groups both at the workplace and while traveling to and from work;
 - (3) ban provocative religious or political emblems from the workplace;
 - (4) publicly advertise all job openings and make special recruitment efforts to attract applicants from underrepresented religious groups;
 - (5) establish layoff, recall and termination procedures which do not in practice favor a particular religious group;
 - (6) abolish all job reservations, apprenticeship restrictions and differential employment criteria which discriminate on the basis of religion;
 - (7) develop training programs that will prepare substantial numbers of current employees from underrepresented religious groups for skilled jobs, including the expansion of existing programs and the creation of new programs to train, upgrade and improve the skills of workers from underrepresented religious groups;
 - (8) establish procedures to assess, identify and actively recruit employees from underrepresented religious groups with potential for further advancement; and
 - (9) appoint a senior management staff member to oversee affirmative action efforts and develop a timetable to ensure their full implementation.
- C. For purposes of this Certification, “Northern Ireland” shall be understood to be the six counties partitioned from the Irish Province of Ulster, and administered from London and/or from Stormont.
- D. The Contractor agrees that the warranties and representation in paragraph “A” are material conditions of this Contract. If the City receives information that the Contractor is in violation of paragraph “A”, the City shall review such information and give the Contractor opportunity to respond. If the City finds that such a violation has occurred, the City may declare the Contractor in default, and/or terminate this Contract. In the event of any such termination, the City may procure the supplies, services or work from another source in accordance with applicable law. The Contractor shall pay to the City the difference between the contract price for the uncompleted portion of this Contract and the cost to the City of completing performance of this Contract either by itself or by engaging another contractor. If this is a contract other than a construction contract, the Contractor shall be liable for the difference in price if the cost of procurement from another source is greater than what the City would have paid the Contractor plus any reasonable costs the City incurs in any new procurement and if this is a construction contract, the City shall also have the right to hold the Contractor in partial or total default in accordance with the default provisions of this Contract. In addition, the Contractor may be declared not to be a responsible bidder or proposer for up to three (3) years, following written notice to the Contractor, giving the Contractor the opportunity for a hearing at which the Contractor may be represented by counsel. The rights and remedies of the City hereunder shall be in addition to, and not in lieu of, any rights and remedies the City has pursuant to this Contract or by operation of law or in equity.

Agreed:

(Legal Name of Person, Firm or Corporation)

By:

(Signature of Authorized Representative)

(Title)

Dated:

SWORN to before me this _____ day
of _____, 20__

Notary Public

YONKERS JOINT SCHOOLS CONSTRUCTION BOARD BID PACKAGE DIVERSIFICATION DOCUMENTS

See the following page(s) for the instructions and the forms required to be submitted with the Bids

Please note that the instructions for the forms indicate that Bidders are to utilize the Excel forms, but this is not correct, fill in the pdf forms and submit with the Bid.

The Good Faith Efforts Checklist following the forms is required to be completed and submitted with the Bid Package Diversification Documents.

Yonkers Joint School Construction Board

Minority and Woman-Owned Business Enterprise Diversification Forms to be submitted with bid documents

Table of Contents

Page (s)

Instructions for YJSCB Front End Diversification Documents	1 – 2
YJSCB Front End Diversification Documents	3 - 6

Instructions for YJSCB Minority and Woman-Owned Business

Enterprise Diversification Forms to be submitted with bid package

Page 1

PRIME INFORMATION: Please select company service category. Enter full name of company, address, contact person, email address and contact phone number.

PROJECT INFORMATION: Please enter the Contract/Bid dollar amount.

Enter the MBE goal dollar value.

Enter the WBE goal dollar value.

Enter the name of the school and/or the building if separate from the school.

Enter the address, city, county and zip code

Enter a brief description of the work to be completed

PROPOSED MWBE UTILIZATION: Complete and submit original Excel MWBE Utilization spreadsheet included as part of the diversity document package. See instructions for Page 2.

Type the name of Principal or Officer completing this form.

Type the title of Principal or Officer completing this form

Principal or Officer must sign and date this form.

Page 2

Please utilize the Excel version of page 2 and submit the original with your plan.

List ALL subcontractors and suppliers that you plan to utilize during the performance of this contract.

Enter the complete firm name, a brief work description, the value of the proposed subcontractor contract, the name of the contact person, the telephone number of the contact person, the email address of the contact person, complete address of the firm. Please include the estimated start date for the work this firm will perform, and whether they are an MBE firm, a WBE firm or other firm. If additional space is needed, please contact Landon & Rian Enterprise.

Type the name of Principal or Officer completing this form.

Type the title of Principal or Officer completing this form

Principal or Officer must sign and date this form.

Page 3 – Standard Equal Opportunity Policy Statement

Indicate whether you are a Prime Contractor or Prime Consultant.

Enter the full name of the firm, the complete address, city, state and zip code.

Enter the name of the person to be contacted regarding the Utilization Form and their telephone number. This person should be prepared to answer questions regarding this plan.

Enter the name of the school and/or the building if separate from the school

Enter the address, city, county and zip code

Enter a brief description of the work to be completed

Enter the full name of the firm completing this Plan in each of the spaces provided.

Page 4 – MWBE and EEO Contract Goals

Please enter initials of the person completing this form for MWBE and EEO Contract Goals

Type the name of Principal or Officer completing this form.

Type the title of Principal or Officer completing this form

Principal or Officer must sign and date this form.

YJSCB Bid Package Diversification Documents

A. PRIME INFORMATION: CONTRACTOR

CONSULTANT

Name:

Address:

Contact Person:

City:

Email:

State:

Zip:

Phone #:

PROJECT INFORMATION:

Contract/Bid Amount: \$

MBE Goal = 20% \$

WBE Goal = 10% \$

School/Building(s) Name:

Address:

City:

Work Description:

County:

Zip:

B. PROPOSED MWBE UTILIZATION:

Complete and submit original Excel MWBE Utilization spreadsheet included as part of the diversity document package. See example on page 2.

Type Name of Principal or Officer

Type Title of Principal or Officer

Date

B. List **ALL** subcontractors and suppliers you plan to utilize during the performance of this contract:

***NOTE: A completed Scope Verification Form YJSCB (10/06/2021) must accompany this Utilization Plan for each MWBE subcontractor and/or supplier listed. A blank form is included in the Contract Documents. Incomplete or nonsubmittal of the form(s) will delay approval of the Utilization Plan.

School Name here

Contract Amount:

Subcontractor Listing - Utilization Plan

Contractor Name:	Work Description	Contract Value	Contact Person	Telephone	Email Address	Address	City	State	Zip	Estimated Start Date	Type of Firm			Scope Verification submitted	Workforce Plan Submitted
											MBE	WBE	Other		
SUBCONTRACTORS															

MWBE Goal Calculation	
20%	10%
MBE	WBE

SUPPLIERS (Please Note that 50% of supplier contract values are counted toward the goal)

Name of Principal or Officer

Title of Principal or Officer

Signature of Principal or Officer

Date

Credit	\$	0	\$	0
Goal	\$	-	\$	-
Over/(Shortfall)	\$	0	\$	0
Waiver		#DIV/0!		#DIV/0!

D. STANDARD EQUAL OPPORTUNITY POLICY STATEMENT

PRIME INFORMATION: CONTRACTOR CONSULTANT

Name:

Address:

City:

State:

Zip:

Contact Person:

Telephone:

PROJECT INFORMATION:

School/Building(s) Name:

Address:

City:

County:

Zip:

Work Description:

The following is a statement of _____'s commitment to provide participation by minority persons and women in the workforce at the above referenced project:

Will ensure and maintain a working environment free of harassment, intimidation and coercion and shall specifically ensure that all foremen, superintendents and other supervisory personnel are aware of and carry out our commitment to maintain such a working environment.

Will establish and maintain a current list of minority and women recruitment sources and notify such sources and minority and community organizations when employment opportunities are available and maintain a record of the sources and organizations' responses.

Will maintain a file of the names and address of each minority person and woman referred to it by any individual, recruitment source or community organization and of what action was taken with respect to each such referred individual. If the individual was not employed, the file will contain the reasons.

Will disseminate this equal employment opportunity policy statement within the organization and will provide all subcontractors with a copy, discussing it with them prior to commencing work at the job site. A copy of our equal employment policy shall be posted at the job site at all times.

Please initial below in acknowledgment of the individual participation goals per the YJSCB Diversification Plan.

MWBE Contract Goals

30% Minority and Women's Business Enterprise Participation

20% Minority Business Enterprise Participation

10% Women's Business Enterprise Participation

EEO Contract Goals

20% Minority Labor Force Participation

10% Female Labor Force Participation

Type Name of Principal or Officer

Type Title of Principal or Officer

Signature of Principal or Officer

Date

**YONKERS JOINT SCHOOLS CONSTRUCTION BOARD BID PACKAGE
DIVERSIFICATION DOCUMENTS - GOOD FAITH EFFORTS CHECKLIST (submit with Bid)**

The Yonkers Joint School's Board (YJSCB) welcomes your participation in the Yonkers School's Modernization Program (YSMP). Your participation and support in complying with the goals for diversity set forth in the Diversity Plan is critical to the success of the Program. Pursuant to the requirements set forth in this Section and in consideration of the privilege to submit Proposals on contracts funded, in whole or in part, by YJSCB, WE, _____ by Owner/Principal

Attest that we have exercised the following Good Faith Efforts in addition to my /our regular and customary solicitation process:

I/We have delivered written notice to three available certified MWBE's for each potential subcontracting or supply category in the Contract AND all potential subcontractors or vendors which requested information on the Contract.

I/We have provided all potential subcontractors or vendors with adequate information as to plans, specifications, relevant terms and conditions of the Contract, bonding requirements, and the last date and time for receipt of price quotations.

I/We have attended a special meeting called to inform business and individuals of subcontracting or supply opportunities.

I/We have, in accordance with normal industry practices, divided the contract into economically feasible segments that can be performed by a MWBE.

I/We have provided a written explanation for rejection of any potential subcontractor or vendor to the MWBE, including the name of the firm proposed to be awarded the subcontract or supply agreement, where price competitiveness is not the reason for rejection.

I/We have actively solicited, through sending letters or initiating personal contact, MWBE's in all feasible and appropriate categories providing subcontracting opportunities for the contract under consideration.

I/We have utilized the services of available community organizations and associations, contractors' groups, and trade associations known to publicize contracting and procurement opportunities, for the purpose of obtaining assistance in the contacting and recruitment of MWBE's for the YJSCB's contract under consideration.

I/We have advertised in publications of general circulation in the Yonkers MSA trade publications and other media owned by, or otherwise focused or marketed to MWBE's, and the advertisement identifies and describes the specific subcontracting or other opportunity in reasonable detail.

I/We have conducted discussions with interested MWBE's in good faith, and provided the same willingness to assist MWBE's as has been extended to any other similarly situated subcontractor.

(GOOD FAITH EFFORTS CHECKLIST continued on following page):

(GOOD FAITH EFFORTS CHECKLIST, page 2):

I/We have taken steps to ensure that all labor supervisors, superintendents, and other on-site supervisory personnel are aware of and carry out the obligation to maintain a non-discriminatory work environment, free of harassment, intimidation and coercion at all construction sites, offices and other facilities to which employees are assigned to work.

Please identify below all subcontractors, suppliers, or a joint venture partner you invited to participate that declined.

1. Name of subcontractor/Vendor: _____
Phone #: _____
Address: _____
Date of Offer to Participate: _____
Date Offer was declined: _____
Reasons Given for Declining:

Please note all categories of ownership that apply:

- ___ African American Business Enterprise
- ___ Asian American Business Enterprise
- ___ Hispanic American Business Enterprise
- ___ Majority Enterprise
- ___ Native American Business Enterprise
- ___ Small Business Enterprise
- ___ Women-Owned Business Enterprise

2. Name of subcontractor/Vendor: _____
Phone #: _____
Address: _____
Date of Offer to Participate: _____
Date Offer was Declined: _____
Reasons Given for Declining:

Please note all categories of ownership that apply:

- ___ African American Business Enterprise
- ___ Asian American Business Enterprise
- ___ Hispanic American Business Enterprise
- ___ Majority Enterprise
- ___ Native American Business Enterprise
- ___ Small Business Enterprise
- ___ Women-Owned Business Enterprise

(GOOD FAITH EFFORTS CHECKLIST continued on following page):

(GOOD FAITH EFFORTS CHECKLIST, page 3):

3. Name of subcontractor/Vendor: _____
Phone #: _____
Address _____
Date of Offer to Participate: _____
Date Offer was Declined : _____

Reasons Given for Declining:

Please note all categories of ownership that apply:
 African American Business Enterprise
 Asian American Business Enterprise
 Hispanic American Business Enterprise
 Majority Enterprise
 Native American Business Enterprise
 Small Business Enterprise
 Women-Owned Business Enterprise Name of subcontractor/Vendor

4. Name of subcontractor/Vendor: _____
Phone #: _____
Address _____
Date of Offer to Participate: _____
Date Offer was Declined: _____

Reasons Given for Declining:

Please note all categories of ownership that apply:
 African American Business Enterprise
 Asian American Business Enterprise
 Hispanic American Business Enterprise
 Majority Enterprise
 Native American Business Enterprise
 Small Business Enterprise
 Women-Owned Business Enterprise Name of subcontractor/Vendor

END OF GOOD FAITH EFFORTS CHECKLIST



ONE LARKIN CENTER, 3RD FLOOR
 Yonkers, New York 10701
 (914) 377-6035
 Fax: (914) 377-6032
 thomas.collich@yonkersny.gov

CITY OF YONKERS
Purchasing

Mike Spano, Mayor
Tom Collich, Director

VENDOR BACKGROUND QUESTIONNAIRE

BID NUMBER: IFB-6711

OPENING DATE 12/10/21

This questionnaire has been developed to collect information from vendors/contractors wishing to do business with the City of Yonkers.

Please complete the questionnaire carefully, answering all questions completely accurately. Answers **must be typewritten or printed in black or blue ink**. If you need more space to answer a question, **type or print the answer on company letterhead** and attach it to the questionnaire. **ANSWER ALL QUESTIONS - DO NOT LEAVE BLANKS**. Failure to submit a complete and accurate questionnaire may result in your bid or proposal being rejected as non-responsive and, therefore, ineligible for award.

GENERAL INFORMATION Initial Application: YES NO Revision: YES NO

1. Submitting Business Name _____
 EIN/SSN _____
 Dun & Bradstreet # _____
 "Doing Business As" Name(s), if any _____
 Business Address and date business _____
 located at this address _____
 Other business addresses, if any (satellite _____
 offices, plants, warehouses, branch offices _____
 headquarters, etc.) _____
 Mailing address, if different from above _____

 Telephone Number _____
 Fax Number _____
 E-Mail _____
 Contact Person and Title _____

2. Does this business now, or has it in the past 10 years, used an EIN, SSN, Name, Trade Name or abbreviation other than those given in the above question? YES NO If YES, please provide details and explain: _____

3. Has this business changed address(es) in the past five years? YES NO . If YES, please provide all complete former addresses:
- _____
- _____
4. a. Date business was formed _____
 b. Date business was incorporated _____
5. Type of Organization (Please circle one)
 a. Business Corporation
 State/County in which incorporated _____
 Name of individuals/entities incorporating business _____
 b. Sole Proprietorship
 c. General Partnership/ Limited Partnership
 State or County where partnership certificate/agreement is filed _____
 d. Joint Venture
 e. Non Profit
 f. Not for Profit
 g. Other (Explain) _____
6. Type of Business (Please circle one)
 a. Manufacturing
 b. Distribution
 c. Retail
 d. Commercial Service
 e. Professional Service, Non Construction, Non-Law
 f. Bank
 g. Construction Manager
 h. Architect
 i. Engineer
 j. General Contractor
 k. Consultant (Specify) _____
 l. Laboratory Testing and Analysis
 m. Law Firm
 n. Other (Explain) _____
7. Has this business been certified by a government entity (SBA, NYC, etc.) as a Minority Business, Women-Owned Business, Disadvantaged Business or Small Business Enterprise? YES , NO . If YES, please explain. _____
- _____
- _____
- a. Do you perform outreach to any of these Enterprises to perform subcontracting work?
 YES , NO
- b. Will you use one of these Enterprises as a subcontractor on work performed for the City of Yonkers? YES , NO If YES, explain. _____

BUSINESS HISTORY

8. Was this business purchased as an existing business by its present owners? YES , NO
If YES, please provide date of purchase and name(s) of previous owner(s).

9. Does this business own , rent , or lease its office facilities? **(Please check one)**
If leased or rented, please provide name, address, and telephone number of building owner/
landlord.

10. Does this business share office space, staff, equipment, or expenses with any other
business or not-for-profit organization? YES , NO If YES, please provide the
name and address of the other entity and nature of relationship to this business.

11. Will this business use or occupy any real property, other than the addresses listed in
response to Question 1., to carry out the terms of any contract you may receive from the
City of Yonkers?
YES , NO . If YES, please provide details and explain.

BUSINESS PRINCIPALS

12. For all proprietors, partners, directors, officers, shareholders of 5% or more of the businesses’
issued stock, any manager or individual who takes part in overall policy making or financial
decisions for the business, and any person in a position to control or direct the businesses’
overall operations, please provide name, home address, date of birth, social security number,
title, percentage of ownership, and business telephone number.

13. Number of Employees _____
14. Is this business now or has it been in the last five years a subsidiary of another business?
YES , NO . In this period, has another business been a partner in this business, or has
another business been affiliated with this business through common ownership,
management or agreement, or has another business owned 5% or more of this business?
YES , NO . If YES, please provide details and explain.

15. Has this business or any other business listed in response to question 14 pledged or hypothecated 5% or more of its stock to another business or to an individual to guarantee payment for a debt or obligation? YES , NO . If YES, please provide details and explain.

16. Is this business or any business listed in response to question 14 now or has it been in the last five years:

- a. The owner of 5% or more or in control of another business, an affiliate or a subsidiary? YES , NO
- b. A vendor of or contractor to the City of Yonkers? YES , NO
- c. A subcontractor on any contract with the City of Yonkers? YES , NO .

If YES to any above, please provide details and explain. _____

17. Are any of the persons listed in answer to question 12 now or have been in the past, elected or appointed officials or officers or employees of the City of Yonkers? YES , NO

If YES, please provide details and explain. _____

18. Has this business or any business listed in response to question 14 at present or has it ever been:

- a. Debarred by any agency* from entering contracts? YES , NO .
- b. Found not responsible by any government agency? YES , NO .
- c. Declared in default and/or terminated for cause on any contract, and/or had any contract cancelled for cause? YES , NO .
- d. Suspended by any government agency from entering any contract with it? YES , NO .
- e. Party to any action pending that could formally debar or otherwise effect this business' ability to bid or propose on contracts? YES , NO .
- f. A respondent before the Grand Jury or any Federal, State or City Board? YES , NO
- g. Unable to execute a contract with a government agency because it could not provide the required security or obtain a surety bond? YES , NO .
- h. Required to pay liquidated damages on a contract? YES , NO .
- i. In default on any obligation to, or subject to any unsatisfied judgment or lien obtained by a government agency, including judgments based on taxes owed? YES , NO .
- j. Filed a bankruptcy petition or been subject to any involuntary bankruptcy proceedings? YES , NO
- k. Subject of termination for cause or revocation of permits, licenses, concessions, franchises, or leases? YES , NO .
- l. Subject of a criminal investigation** or civil anti-trust investigation by any Federal, State or Local prosecutorial or investigative agency? YES , NO .
- m. Subject of an investigation by any government agency, including regulatory agencies (Security Exchange Commissions, Federal Communications Commission, Department of Consumer Affairs, etc.) YES , NO .

If you answered YES TO ANY OF THE QUESTIONS IN ITEM 18, please provide details on company letterhead including dates, agency/entity names, and disposition.

* Government agency includes City, State and Federal Public Agencies, quasi-public agencies, authorities and corporations, public development corporations and local development corporations.

** An investigation includes an appearance before a grand jury by a person or representatives of a business entity, any oral or written inquiry or review of documents by a public agency, temporary commission or other investigative body, or questioning concerning the general operation or a specific project or activities of business entity or the activities of a person.

19. In the last five years, have any of the persons listed in response to question 12:

- a). Been the subject of an investigation involving any alleged violation of criminal law? YES , NO .
- b). Been arrested, indicted or named as an unindicted co-conspirator in any indictment or other legal instrument? YES , NO .
- c). Been convicted, after trial or by plea, of any felony under State or Federal Law? YES , NO .
- d). Been convicted of any misdemeanor involving business-related crimes? YES , NO .
- e). Entered a plea of nolo contendere in a legal proceeding? YES , NO .
- f). Entered a consent decree? YES , NO .
- g). Been granted immunity from prosecution for any business-related conduct constituting a crime under State or Federal Law? YES , NO .

If you answered YES TO ANY OF THE QUESTIONS IN ITEM 19, please provide details on company letterhead including dates, agency/entity names, and disposition.

20. Has any person listed in response to question 12 been employed by or affiliated with any person or business that has:

- a. Been the subject of an investigation involving any alleged violation of criminal law? YES , NO .
- b. Been arrested, indicted or named as an unindicted co-conspirator in any indictment or other legal instrument YES , NO .
- c. Been convicted, after trial or by plea, of any felony under State or Federal Law? YES , NO .
- d. Been convicted of any misdemeanor involving business-related crimes? YES , NO .
- e. Entered a plea of nolo contendere in a legal proceeding? YES , NO .
- f. Entered a consent decree? YES , NO .
- g. Been granted immunity from prosecution for any business – related conduct constituting a crime under State or Federal Law? YES , NO .

If you answered YES TO ANY OF THE QUESTIONS IN ITEM 20, please provide details on company letterhead including dates, agency/entity names, and disposition.

21. Has this or any business listed in response to question 14 or any person listed in response to question 12 failed to pay any applicable Federal, State or Local government taxes for the past five years?

YES , NO . If YES, explain _____

22. In the past five years, has this or any business listed in response to question 14 or any person listed in response to question 12 committed any act of collusion, bid rigging or price fixing in submitting a competitive bid? YES , NO .

If YES, explain _____

23. Licensing: List jurisdiction and trade categories in which your organization is legally qualified to do business (if applicable), and attach legible copies of registrations and/or licenses.

<u>Jurisdiction</u>	<u>Trade Category</u>
_____	_____
_____	_____
_____	_____

24. Pursuant to Executive Order No 6-2013, “delinquent Contractors shall not be deemed responsible bidders for purposes of awarding contract. It is the policy of the City of Yonkers to disqualify persons or business entities which are delinquent in financial obligations to the City or its affiliated agencies, boards or commissions from participating in City contracts and business opportunities.” Is the Contractor currently delinquent in its financial obligations to the City or its affiliated agencies, boards or commissioners?

YES , NO .

If YES, explain _____

25. Does the Contractor or Controlling Person(s) own any property within the City of Yonkers? YES NO

If “Yes,” please list the address of each property.

CERTIFICATION

A materially false statement willfully or fraudulently made in connection with this questionnaire is sufficient cause for rendering the business entity not responsible with respect to the present bid or proposal and future bids or proposals, and in addition, may subject the person and/or entity making the false statement to criminal charges, including but not limited to New York State Penal Law sections 175.35 (Offering a false statement for filing) and 210.40 (Sworn false statement) and/or Title 18 U.S.C. sections 1001 (False or fraudulent statement) and 1341 (Mail fraud).

I, _____, being duly sworn, state that I am the
Print or Type Name of Bidder/Proposer Authorized Representative

_____ of _____, and Print or
Type Title of Bidder/Proposer Authorized Representative Print or Type Name of Entity Submitting
Bid/Proposal

I have read and understand the questions contained in the attached questionnaire and its appendices. I certify that to the best of my knowledge the information given in response to each question and appendices is full, complete, and truthful.

I will notify the City of Yonkers in writing of any change in circumstances occurring after the submission of this questionnaire and before the execution of any contract with the City.

I acknowledge that the City of Yonkers may, by means it deems appropriate, determine the accuracy and truth of the statements made in this questionnaire.

I recognize that all information submitted is for the express purpose of inducing the City to enter a contract with the submitting business entity.

I authorize the City to contact any entity or person named in this questionnaire, for purposes of verifying the information submitted.

Signature of Bidder/Proposer Authorized Representative

STATE OF _____)
) ss:
COUNTY OF _____)

On the _____ day of _____, in the year _____, before me personally came
_____, to me known and known to me to be the person
Print or Type Name of Bidder/Proposer Authorized Representative

described in and who executed the foregoing instrument, and he/she duly acknowledged that he/she executed the same.

Notary Public

Place Notary Public Stamp Here:

CITY OF YONKERS BIDDER'S AFFIDAVIT

Bid No.: **IFB-6711**

Project: **COMMUNITY SCHOOL 35**

By submission of this Bid and the execution of the Bidder's Affidavit, each bidder and each person signing on behalf of any bidder certifies, and in the case of a joint bid each party thereto certifies on behalf of its own organization, under penalty of perjury, that to the best of his/her knowledge and belief:

- A. Fair and Ethical Business Practices will be strictly adhered to during the life of this Contract. During the term of this Contract, neither the Bidder nor any director, partner, principal, officer or employee shall:
 - 1) File with a government office or employee, a written instrument which intentionally contains a false statement or false information;
 - 2) Intentionally falsify business records;
 - 3) Give, or offer to give, money or any other benefit to a labor official with intent to influence that labor official with respect to any of his or her acts, duties or decisions as a labor official;
 - 4) Give, or offer to give, money or any other benefit to a public servant with intent to influence that public servant with respect to any of his or her acts, duties or decisions as a public servant; and
 - 5) Knowingly participate in the criminal activities of any organized crime group, syndicate or family, nor shall any person employed by or associated with any such organized crime family, syndicate or group participate through criminal means in any of the business affairs of the Bidder.

- B. In addition, if it becomes known that any director, partner, officer, employee of the Bidder, or any shareholder owning 5% or more of the Bidder's stock:
 - 1) is the subject of investigation involving any violation of criminal law or other federal, state or local law or regulation by any governmental agency; or
 - 2) is arrested, indicted or named as an unindicted co-conspirator in any indictment or other accusatory instrument; or
 - 3) is convicted of any felony under state or federal law and/or any misdemeanor involving a business-related crime.

The Bidder shall immediately notify the City of Yonkers of any such event.

AFFIDAVIT WHERE THE BIDDER IS A CORPORATION

STATE OF _____, COUNTY OF _____

as:

_____ being duly sworn,

says:

I am a member of _____,
the above named corporation whose name is subscribed to and which executed the foregoing bid and Bidders Affidavit. I reside at _____
_____.

I have full knowledge of the matters pertaining thereto.

(Signature of the person who signed the Bid)

ACKNOWLEDGEMENT WHERE THE CONTRACTOR IS A CORPORATION

STATE OF _____)
) ss:
COUNTY OF _____)

On the _____ day of _____, in the year 20__, before me personally came _____, to me known, who, being by me duly sworn, did depose and say that he/she resides at _____, that she is the _____ of _____, the corporation described in and which executed the above instrument; and that he/she signed his/her name thereto by order of the Board of Directors of said corporation.

Notary Public

If a Corporation, Bidder must complete both Affidavit and Acknowledgement sections and submit with its bid

AFFIDAVIT WHERE BIDDER IS A PARTNERSHIP

STATE OF _____, COUNTY OF _____
as:

_____ being duly sworn,
says:

I am a member of _____ the above named partnership whose name is subscribed to and which executed the foregoing bid and Bidders Affidavit. I reside at _____ . I have full knowledge of the matters pertaining thereto.

(Signature of the person who signed the Bid)

ACKNOWLEDGEMENT OF CONTRACTOR, IF A PARTNERSHIP

STATE OF _____)
) ss:
COUNTY OF _____)

On the _____ day of _____, in the year 20__, before me personally came _____, to me known and known to me to be a member of the firm _____; described in and who executed the foregoing

instrument; and he/she duly acknowledged to me that he/she executed the same for and in behalf of said firm for the uses and purpose mentioned therein.

 Notary Public

If a Partnership, Bidder must complete both Affidavit and acknowledgement sections and submit with its bid.

AFFIDAVIT WHERE BIDDER IS AN INDIVIDUAL

STATE OF _____, COUNTY OF _____
 as:

_____ being duly sworn,
 says:

I am the person who submitted the foregoing bid and Bidders Affidavit. I have full knowledge of the matters pertaining thereto.

 (Signature of the person who signed the Bid)

ACKNOWLEDGEMENT OF CONTRACTOR, IF AN INDIVIDUAL

STATE OF _____)
) ss:
 COUNTY OF _____)

On the _____ day of _____, in the year 20____, before me personally same _____, to me known and known to me to be the person described in and who executed the foregoing instrument, and he/she duly acknowledged that the/she executed the same.

 Notary Public

If an Individual, Bidder must complete both Affidavit and Acknowledgement sections and submit with its bid.

AFFIDAVIT WHERE BIDDER IS A LIMITED LIABILITY COMPANY (LLC)

STATE OF _____, COUNTY OF _____
 as:

_____ being duly sworn,
 says:

I am a member of _____ the above named Limited Liability Company (LLC) whose name is subscribed to and which executed the foregoing bid and Bidders Affidavit. I reside at _____. I have full knowledge of the matters pertaining thereto.

 (Signature of the person who signed the Bid)

ACKNOWLEDGEMENT OF CONTRACTOR, IF A LIMITED LIABILITY COMPANY (LLC)

STATE OF _____)
) ss:
 COUNTY OF _____)

On the _____ day of _____, in the year 20____, before me personally came _____, to me known and known to me to be a member of the firm _____; described in and who executed the foregoing instrument; and he/she duly acknowledged to me that he/she executed the same for and in behalf of said firm for the uses and purpose mentioned therein.

 Notary Public

If a Limited Liability Company (LLC), Bidder must complete both Affidavit and acknowledgement sections and submit with its bid.

The following additions, substitutions, or clarifications are extracted from the (5) Bid Addenda issued with this project during bidding. This insert is intended to summarize addendum information relevant to this specification section. See Bid Addenda issued by the City of Yonkers for complete contract document changes.

Bid Addendum No. 3:

Amend to remove references to Project Labor Agreement. See attachment.

STATEMENT OF CONTRACTOR'S APPRENTICESHIP PROGRAM COMPLIANCE

This statement must be submitted by the Contractor with his proposal. All questions must be answered.

1. Name of Bidder _____

2. Phone Number _____

3. Permanent main office address _____

4. The undersigned hereby affirms that he/she understands and will comply with the requirements set forth under Chapter 355 of the Laws of the State of New York 2016, which was enacted on September 29, 2016 and is known as the Yonkers City School District Joint Schools Construction and Modernization Act (the "Act") wherein the Yonkers Joint Schools Construction Board ("YJSCB") requires that contractors and subcontractors on construction contracts exceeding three million dollars (\$3,000,000.00) participate in apprenticeship training programs registered by the New York State Department of Labor. Participation in such an apprenticeship program pursuant to the Act means the contractor or subcontractor: (1) is signatory to a collective bargaining agreement with a labor organization which sponsors an apprenticeship program registered with the department of labor; or (2) individually sponsors an apprenticeship program registered by the department of labor. In all cases, such apprenticeship program must be specific to the type and scope of work which is being performed.

Dated at _____ this _____ day of _____, 20____.

Name of CONTRACTOR

BY / TITLE

The following additions, substitutions, or clarifications are extracted from the (5) Bid Addenda issued with this project during bidding. This insert is intended to summarize addendum information relevant to this specification section. See Bid Addenda issued by the City of Yonkers for complete contract document changes.

Bid Addendum No. 3:

Remove "DRAFT" watermark from AIA Document A310. See attachment.

AIA Documents that are not included in this Addendum, and are marked with the "DRAFT" watermark, are to be considered as final documents, not draft documents. These forms include, but not limited to, AIA A132 Standard Form of Agreement Between Owner and Contractor, A232 General Conditions of the Contract for Construction, A312 Performance Bond and A312 Payment Bond.

 **AIA**® Document A310™ – 2010**Bid Bond****CONTRACTOR:**

(Name, legal status and address)

SURETY:

(Name, legal status and principal place of business)

OWNER:

(Name, legal status and address)

Yonkers Joint Schools Construction Board
City Hall
40 South Broadway
Yonkers, NY 10701

BOND AMOUNT: \$**PROJECT:**

(Name, location or address, and Project number, if any)

Community School 35
121 McLean Avenue,
Yonkers, NY 10705

The Contractor and Surety are bound to the Owner in the amount set forth above, for the payment of which the Contractor and Surety bind themselves, their heirs, executors, administrators, successors and assigns, jointly and severally, as provided herein. The conditions of this Bond are such that if the Owner accepts the bid of the Contractor within the time specified in the bid documents, or within such time period as may be agreed to by the Owner and Contractor, and the Contractor either (1) enters into a contract with the Owner in accordance with the terms of such bid, and gives such bond or bonds as may be specified in the bidding or Contract Documents, with a surety admitted in the jurisdiction of the Project and otherwise acceptable to the Owner, for the faithful performance of such Contract and for the prompt payment of labor and material furnished in the prosecution thereof; or (2) pays to the Owner the difference, not to exceed the amount of this Bond, between the amount specified in said bid and such larger amount for which the Owner may in good faith contract with another party to perform the work covered by said bid, then this obligation shall be null and void, otherwise to remain in full force and effect. The Surety hereby waives any notice of an agreement between the Owner and Contractor to extend the time in which the Owner may accept the bid. Waiver of notice by the Surety shall not apply to any extension exceeding sixty (60) days in the aggregate beyond the time for acceptance of bids specified in the bid documents, and the Owner and Contractor shall obtain the Surety's consent for an extension beyond sixty (60) days.

If this Bond is issued in connection with a subcontractor's bid to a Contractor, the term Contractor in this Bond shall be deemed to be Subcontractor and the term Owner shall be deemed to be Contractor.

When this Bond has been furnished to comply with a statutory or other legal requirement in the location of the Project, any provision in this Bond conflicting with said statutory or legal requirement shall be deemed deleted herefrom and provisions conforming to such statutory or other legal requirement shall be deemed incorporated herein. When so

ADDITIONS AND DELETIONS:

The author of this document has added information needed for its completion. The author may also have revised the text of the original AIA standard form. An *Additions and Deletions Report* that notes added information as well as revisions to the standard form text is available from the author and should be reviewed. A vertical line in the left margin of this document indicates where the author has added necessary information and where the author has added to or deleted from the original AIA text.

This document has important legal consequences. Consultation with an attorney is encouraged with respect to its completion or modification.

Any singular reference to Contractor, Surety, Owner or other party shall be considered plural where applicable.

Init.

AIA Document A310™ – 2010. Copyright © 1963, 1970 and 2010 by The American Institute of Architects. All rights reserved. **The "American Institute of Architects," "AIA," the AIA Logo, and "AIA Contract Documents" are registered trademarks and may not be used without permission.** This document was produced by AIA software at 09:40:31 ET on 11/23/2021 under Order No.1232252859 which expires on 01/31/2022, is not for resale, is licensed for one-time use only, and may only be used in accordance with the AIA Contract Documents® Terms of Service. To report copyright violations, e-mail copyright@aia.org.

User Notes:

(1298679879)

furnished, the intent is that this Bond shall be construed as a statutory bond and not as a common law bond.

Signed and sealed this day of ,

(Witness)

(Witness)

(Contractor as Principal)

(Seal)

(Title)

(Surety)

(Seal)

(Title)

Init.

/

Section 00 43 31 (“MWBE Utilization and Workforce Diversity”)

YONKERS JOINT SCHOOLS CONSTRUCTION BOARD

**Diversity Plan for Construction Pursuant to Phase I of the
Comprehensive Joint Schools
Construction and Modernization Plan**

TABLE OF CONTENTS

I. INTRODUCTION 1

II. GOALS & PURPOSES1

III. INDEPENDENT COMPLIANCE OFFICER & MWBE UTILIZATION MASTER PLAN 2

IV. MBE & WBE MEANINGFUL PARTICIPATION3

 A. WORKFORCE DEVELOPMENT AND DIVERSITY PRINCIPLES AND RULES3

 1. WORKFORCE DEVELOPMENT AND DIVERSITY PRINCIPLES 3

 2. WORKFORCE DEVELOPMENT AND DIVERSITY RULES 4

 a. Applicability of the Rules & Good Faith Efforts to Comply 4

 b. Workforce Development and Diversity Goals4

 c. Bid Submission & Compliance Reporting Requirements 5

 d. Failure to Maintain Workforce Diversity Goals or to Comply with
 Reporting Requirements 5

 B. BUSINESS DEVELOPMENT AND DIVERSITY PRINCIPLES AND RULES 6

 1. BUSINESS DEVELOPMENT PRINCIPLES 6

 2. BUSINESS DEVELOPMENT AND DIVERSITY RULES 7

APPENDIX (SUPPLEMENTAL INFORMATION, TERMS AND CONDITIONS) 9

I. INTRODUCTION

The Yonkers Joint Schools Construction Board (the "JSCB" or the "Board") recognizes the need to take action to ensure that minority and women-owned business enterprises ("MBE", "WBE", "MWBE"), as well as minority and women workers are given the opportunity to participate in the performance of the contracts issued by the Board as part of the Phase 1 construction program (the "Program") for school facilities within the City of Yonkers undertaken pursuant to the JSCB's enabling legislation, the Yonkers City School District Joint Schools Construction and Modernization Act (the "Act"). The Board recognizes that this opportunity for the participation in our free enterprise system by persons traditionally, socially and economically disadvantaged is essential to obtain social and economic equality. In addition, the JSCB has been authorized by the Yonkers City School District Joint Schools Construction and Modernization Act to develop and adopt this Diversity Plan.

Accordingly, the Board desires to foster and promote the participation of such individuals and business firms in contracts with the Board and sets forth this initiative (the "Diversity Plan"). The Board envisions the participation goals increasing as capacity increases and plans to:

- a. develop strategies that will create and coordinate efforts to ensure a more diverse workforce for the projects to be undertaken pursuant to the Program as well as to ensure the participation of minority and women-owned business enterprises; and
- b. address accountability for attainment of the diversity goals -- providing a description of the forms of monitoring that will be used, and how such information will be communicated to the public and most importantly to potential participants.

The implementation of this Diversity Plan prior to any start of construction on the Program will result in an effective process for increasing the purchase of goods and services from minority and women-owned businesses.

II. GOALS & PURPOSES

The goals and purposes set forth in this Diversity Plan are consistent with the overall goals and purposes of the JSCB and the Act. The JSCB was created pursuant to the Act for the purpose of facilitating, *inter alia*, the construction of new public school facilities within the City of Yonkers to be utilized by the Yonkers City School District. The JSCB will effectuate the Program consistent with the JSCB's comprehensive joint schools construction and modernization plan (the "Plan"), pursuant to which new public school facilities will be constructed in the City of Yonkers. A program manager (the "Program Manager") will assist the JSCB with the implementation of Phase 1 of the Plan.

In accordance with the Act, the purposes of this Diversity Plan include the following:

- (i) to develop strategies that will create and coordinate efforts to ensure a more diverse workforce for JSCB projects as well as to ensure the participation of minority-owned and women-owned business enterprises;

(ii) to address accountability for attainment of the diversity goals by, among other things, providing a description of the forms of monitoring that will be used, and how such information will be communicated to the public and most importantly to potential participants;

(iii) to promote equal and increased opportunities for under-represented business and labor segments;

(iv) to encourage, assist and sustain business development with respect to under-represented populations (including Minorities and Women);

(v) to facilitate appropriate community input and public discussion and develop strategies that would create and coordinate any efforts to ensure a more diverse workforce for the projects;

(vi) to develop diversity goals for the Program in furtherance of the JSCB's commitment to diversity; and

(viii) to comply with New York State law and all mandated diversity requirements, including, but not limited to, the provisions set forth in the Act, the provisions of Article 15-A of the Executive Law of the State of New York and the provisions set forth in Parts 142 and 143 of Chapter XIV of Title 5 of the New York State Codes, Rules and Regulations ("NYCRR").

III. INDEPENDENT COMPLIANCE OFFICER & MWBE UTILIZATION MASTER PLAN

In compliance with the Act, the JSCB intends to retain an independent compliance officer ("ICO") to perform the duties described in the Act, which include:

- (a) monitoring all of the projects to be undertaken pursuant to the Phase I of the Plan to ensure compliance with this Diversity Plan and all applicable federal, State and local laws, rules and regulations;
- (b) developing an MWBE Utilization Master Plan, for the governance of all project contracts, to the satisfaction of the JSCB to meet disparity as established by existing state studies, to address accountability for attainment of the diversity goals set forth in this Diversity Plan, to provide the forms of monitoring to be used and to provide how such information would be publicly communicated (the ICO shall implement such MWBE Utilization Master Plan in accordance with its terms, all applicable requirements and the provisions of this Diversity Plan);
- (c) developing, implementing, advertising, promoting and monitoring policies and procedures to utilize and provide sufficient MWBE and skilled minority employment

resources participation opportunities to be followed by prime contractors and subcontractors for such projects;

- (d) providing technical assistance to potential MWBE contractors and subcontractors interested in bidding on any projects undertaken pursuant to Phase 1 of the Plan;
- (e) obtaining and maintaining records and documentation as are necessary to confirm compliance with any established MWBE goals for any projects undertaken pursuant to Phase 1 of the Plan;
- (f) identifying contractors in non-compliance with the established MWBE or skilled minority employment resources utilization goals or in willful violation of any federal, state and local laws, rules and regulations;
- (g) monitoring and reporting the upward/downward price adjustment and payment amounts to MWBE's listed on any utilization plan submitted by any contractor for any projects undertaken pursuant to Phase 1 of the Plan;
- (h) developing and working with JSCB to enforce agreed financial or monetary sanctions for any contractor's non-compliance with MWBE Utilization Master Plan;
- (i) having access to all proposed bid specifications, documents, records, drawings, blueprints and any other documentation associated with such bid specifications; and
- (j) reporting to the YJSC board on a monthly basis.

IV. MBE & WBE Meaningful Participation

The actual services provided by the MBE or WBE must be essential in the performance of the scope of work for the applicable contract. Utilization of a certified MBE or WBE as a conduit or pass through for participation credit is strictly prohibited. It is within the discretion of the JSCB (or its designee) to determine whether services are essential in the performance of the scope of work and offer a determination of the appropriateness of work allowed for lower tier subcontracting in accordance with practices generally accepted in the construction industry. Firms submitted or who participate in the Program outside of these conditions and without specific prior approval by the JSCB will not be credited toward the MWBE Utilization Plan and goals for the contract.

A. Workforce Development and Diversity Principles and Rules

1. Workforce Development and Diversity Principles

One of the principal goals of this Diversity Plan is to support workforce development and diversification opportunities that can be created by the Program. This Diversity Plan acknowledges the diverse community of the City of Yonkers and acknowledges the historical disparity experienced by minority and women-owned businesses in gaining access to participate in projects of the kind that will be undertaken

by the JSCB. Additionally, this Diversity Plan strives to create an environment that engages and encourages the participation of these communities.

This Diversity Plan aspires to facilitate the use of a workforce reflective of the City's population and diversity. In order to achieve the development of a diverse workforce for the Program, the Program Manager and/or Prime Contractor(s) shall assist the Independent Compliance Officer (ICO) in overseeing, facilitating, developing, and/or implementing the following:

(i) A community-wide public relations campaign to provide specific information about the Program's employment opportunities, referral and training plans.

(ii) A methodology which assists contractors, suppliers, professional service firms, or any other businesses providing goods and services to the Program to effectuate the workforce diversity goals of this Diversity Plan and the minimum standards to be attained when providing such goods and services to the Program. All contracts shall include remedies and sanctions for noncompliance and identify a means by which inquiries and disputes about Plan requirements may be addressed.

(iii) An independent compliance plan which monitors performance of contractors, suppliers, and professional service firms.

(iv) Regular monthly reporting to the Board setting forth the results of all employment and compliance activity and dispute resolution activities.

2. Workforce Development and Diversity Rules

a. Applicability of the Rules & Good Faith Efforts to Comply

All contractors, suppliers, professional service firms or other businesses providing goods or services with a JSCB contract of \$25,000 or more shall comply with the Workforce Diversity Goals set out below, as well as the other provisions of this Diversity Plan. In the event a business believes that it cannot meet the Workforce Diversity Goals, that business shall submit to the ICO for approval documented evidence of its Good Faith Effort to meet those goals within 5 workdays of being notified by JSCB that they will be awarded a Contract. Within 7 workdays of submittal of the documented evidence of its Good Faith Effort, the ICO will review all demonstrated efforts to meet the established goals and determine whether the business has sincerely attempted to meet the established goals in the Diversity Plan. If the ICO determines that a Good Faith Effort has not been made, the business can request a JSCB hearing within 3 days of receiving notification from the ICO.

b. Workforce Development and Diversity Goals

In order to achieve the goals of this Diversity Plan, each contractor, supplier, professional service firm or other business providing goods or services shall strive to and use best efforts to ensure that the workforce it engages to perform work for the Program shall demonstrate, in terms of the percentage of actual hours worked under the contract and/or contract as amended, participation rates as follows (collectively, Workforce Diversity Goals):

(i) **Minority Workforce:** 20% of project personnel hours including skilled trade's people, journeymen, apprentices, and supervisory staff.

(ii) **Female Workforce:** 10% of project personnel hours including skilled trade's people, journeymen, apprentices, and supervisory staff.

c. Bid Submission & Compliance Reporting Requirements

In order to achieve such development and diversity in its workforce, each contractor, supplier, professional service firm or other business providing goods or services shall:

i. With bid submission, present a proposed written recruiting Plan directed at attracting candidates to fill positions of employment in order to meet Workforce Diversity Goals.

ii. With bid submission, provide a statement committing to training or participation in training programs provided by third parties to train new employees in meaningful ways to succeed in their employment opportunities and to promote long-term employment within the industry or profession.

iii. Provide the ICO with a monthly EEO-Workforce Utilization Report and such other workforce census/employment data and/or certified payroll records necessary to verify achievement of the Workforce Diversity Goals and demonstrate compliance with the minimum standards. Employee zip code information must be listed on this monthly EEO –Workforce Utilization Report.

iv. Provide on-demand access and cooperation to the ICO to review records on-site and/or at work-site premises to validate workforce participation. This may include unannounced visits and on-the-spot interviews that the ICO and its inspectors may hold with workers at the job site or at off-site work premises to verify their work status and claimed job classifications.

d. Failure to Maintain Workforce Diversity Goals or to Comply with Reporting Requirements

In the event any contractor, supplier, professional service firm or other business providing goods or services fails to maintain the Workforce Diversity Goals and/or provide the information required above through the duration of the project on their contract or purchase order, the ICO can delay payment of outstanding monies pending compliance. In addition, the ICO may summon the contractor, supplier, professional service firm or other businesses providing goods or services to appear before a JSCB selected hearing panel. The hearing shall be held within ten (10) business days of the notice of non-compliance by the ICO. After the contractor has had such a hearing the Board may elect to:

i. Withhold payment of any amounts due on the disputed item pending resolution of the non-compliance issue.

ii. Assess liquidated damages in an amount equal to the dollar value that would have been realized if the minority/women workforce goals would have been met.

iii. Withhold, suspend, cancel or terminate the contract or purchase order.

- iv. Identify such contractor as a non-responsive bidder for future contracts within the Program, provided that such remedy is authorized by a vote of the JSCB.

All of the foregoing penalties would be upon a prime contractor, supplier, and professional service firm or other business providing goods or services to the JSCB who failed to comply with the approved utilization plan submitted with its bid for a contract.

B. Business Development and Diversity Principles and Rules

The other major goal of this Plan is to provide for business development opportunities and participation in the Program by minority-owned and women-owned businesses. The following are the principles associated with the implementation of the business development rules of this Diversity Plan:

1. Business Development Principles

The capital investment represented by Phase I of the Yonkers Joint Schools Construction Program creates a unique opportunity for participation of minority-owned and women-owned business enterprises. To ensure that contracts for goods and services are placed with qualified minority and women-owned business enterprises, the Program Manager will oversee, facilitate, develop and/or assist the ICO in implementing the following:

- i. Identify City of Yonkers certified MBE and WBE firms available to provide goods and services to the Program and to create a reference list for all Program participants.
- ii. Identify City of Yonkers firms that could/can be certified as MBE or WBE.
- iii. Ensure that contractors and suppliers divide the goods or services to be provided into scopes, where economically and technically feasible, to create opportunities for participation.
- iv. Coordinate activities and services with organizations such as chambers of commerce, trade groups, and community-based groups/organizations that promote MBE and WBE interests.
- v. Create opportunities for mentoring less experienced and/or start-up M/WBE's.
- vi. Encourage the formation of joint ventures, partnerships, or other similar arrangements where feasible to provide for greater opportunity for MWBE owned firms to participate in the Program.
- vii. Develop a methodology that assists contractors, suppliers, professional service firms, or any other business providing goods or services to the Program to effectuate the business development and diversity goals and the minimum standards to be attained when providing such goods and services. All contracts shall include remedies and sanctions for non-compliance and identify a means by which inquiries and disputes about the project requirements may be addressed.

2. Business Development and Diversity Rules

All contractors, suppliers, professional service firms or other businesses providing goods or services with a JSCB contract of \$25,000 or more shall comply the Business Development/MWBE goals set forth below, as well as the other provisions of this Diversity Plan. In the event a business believes that it cannot meet the Business Development/MWBE Goals, it shall submit to the ICO for approval documented evidence of its Good Faith Effort within 5 workdays of being notified by JSCB that they will be awarded a Contract. Within 7 business days of submittal to meet these goals of the Good Faith Effort, the ICO will review all demonstrated efforts to meet the established goals and determine whether the business has sincerely attempted to meet the established goals in this Diversity Plan. If the ICO determines that a Good Faith Effort has not been made, the business can request a JSCB hearing within 3 days of receiving notification from the ICO.

a. In order to achieve the Business Development/MWBE goals of the Diversity Plan, each contractor, supplier, professional service firm or other business providing goods or services with a Board contract of \$25,000 or more shall strive to and use Good Faith Efforts to engage disadvantaged, or woman-owned business to provide for the following:

- i. MBE: 20% of each contract or purchase order; and
- ii. WBE: 10% of each contract or purchase order.

b. The value of the work procured from certified MBEs and WBEs to accomplish these goals shall be determined as follows:

- i. The dollar value of the work contracted to MBEs and WBEs through a purchase order, less any portion of that value paid by the MBE or WBE to any non-MBE or non-WBE manufacturer or producer to provide such goods and services as a subcontractor or sub-supplier to the MBE/WBE.
- ii. The full dollar value of a sub-contract with all M/WBE firms will be counted toward the diversity goals of the project.
- iii. In the instance of a joint venture, the percentage of the joint venture's profits (or losses) that are to accrue to the MBE or WBE joint venture partner.

c. In the case of a certified minority or women owned supplier that is in the business of supplying goods and materials by maintaining accounts with product manufacturers, paying for goods and materials directly, warehouses goods and materials, provide shipping and handling, and conducts its business as an industry supplier and not a broker, the full value of such contract or purchase order shall meet the project goals. Broker participation will not be counted on this project and will not count toward the Prime Contractors diversity goals.

d. Each contractor, supplier, professional service firm or other business providing goods or services shall solicit bids for subcontractors and suppliers from certified MBE and WBEs including circulation of solicitations to minority contractors, suppliers, trade associations and/or employment and business advocacy groups/organizations. When evaluating bids and/or

proposals received, each contractor, supplier, or professional service firm shall act in "good faith" and shall exercise good faith efforts to assist M/WBE firms to secure such work.

e. To be deemed an MBE or WBE a certificate issued by NYS Empire State Development's (ESD) Division of Minority and Women's Business Development must be presented prior to contract award. Failure to produce an authentic certificate will result in the firm not receiving an MBE or WBE designation for the project, thereby jeopardizing compliance with diversity goals.

f. MBE and WBE designations are honored only for the area/component for which the designation has been provided.

g. Each prime contractor, supplier, professional service firm, or other business providing goods or services under a contract with the JSCB shall provide the ICO with a monthly report demonstrating compliance with the Business Development and Diversity Rules. Initially, in order to obtain certification of any claims for participation, the information submitted must include a signed contract or purchase order that the contractor, supplier, or professional service firm or business has finalized with the certified MBE or WBE firm specifying the level of participation along with the up-to-date certification information on the listed firm. During the term of the contract or purchase order, the contractor, supplier, or professional services firm will need to submit periodic reports to verify the continued participation and final percentage participation of the certified firms. This verification should include monthly payment records, any change orders with the certified contractor and any other supporting data required by the City's Compliance Officer & ICO to verify the claimed level of participation by the certified firms.

h. In the event any contractor, supplier, and professional service firm or other business providing goods or service fails to maintain the Business Diversity Goals and/or submit the information listed in subparagraph 9 above to verify participation or achieve the stated goals through the duration of the contract or purchase order the ICO can delay payment of outstanding monies pending compliance. In addition, the ICO may summon the contractor, supplier or professional service firm or other business providing goods or services to appear before a JSCB selected hearing panel designated by the Board. The hearing shall be held within ten (10) business days of the notice of non-compliance by the ICO. After the contractor has had such a hearing the Board may elect to:

(i) Withhold payment of amounts due pending resolution.

(ii) Assess liquidated damages in an amount equal to the contract dollar value that has not been successfully contracted to meet the MBE or WBE goals.

(iii) Withhold, suspend, cancel or terminate the contract or purchase order.

(iv) Identify such firm as a non-responsive bidder for future contract bids on the Program.

(v) All of the above mentioned penalties would be upon a prime contractor, supplier, and professional service firm or other business providing goods or services to the JSCB who failed to comply with approved utilization plan submitted with its bid for contracts.

APPENDIX

SUPPLEMENTAL INFORMATION, TERMS AND CONDITIONS

A. COMPLIANCE MONITORING

I. Procedure

1. Contract awardees will be notified in the award letter that MWBE (Form A), EEO-Workforce Utilization Report (Form E), Scope Verification form and an EEO Policy Statement are due within 10 business days of the date of the award letter.
2. MWBE and EEO-Workforce Utilization Reports, Scope Verification Forms and the EEO Policy Statement will be submitted to the Program Manager for initial review.
3. The Program Manager will forward MWBE and EEO-Workforce Utilization reports, and Scope Verification forms to the ICO for approval.
4. Approved MWBE and EEO-Workforce Utilization Reports will be forwarded to the ICO prior to contract execution.
5. Once a contract is executed, the Prime Contractor will submit Form C, along with copies of all written subcontracts, invoices and purchase orders and corresponding proofs of payments to the Program Manager for review by the 15th of each month for the duration of its contract.
6. The Program Manager and Prime Contractor will forward Form C, copies of invoices and purchase orders and corresponding proofs of payment to the ICO for approval.
7. The ICO will produce & submit monthly reports to the Board regarding the JSCB Diversity Plan of all open contracts.
8. Once all work has been completed on a contract and prior to close out, the Prime Contractor will submit Form B's to the Program Manager stating the total amount actually paid to the MWBE along with corresponding proof of payment. A separate Form B is needed for each MWBE participating in the contract. Each Form B must be signed by both the prime contractor and the MWBE firm.
9. The Program Manager shall review all Form Bs for completeness and accuracy, and shall forward all such forms to the ICO for approval.
10. The JSCB will be notified of all approved Form B's prior to release of retainage. Actual compliance statistics will be included in the Monthly Compliance Report to the Board.

B. DEFINITIONS

For the purpose of the Program and this Diversity Plan, the following words, terms, phrases and abbreviations shall have the following meanings:

1. "Bidder" shall mean any contractor, vendor or other person, partnership, corporation or other business entity that submits a bid to the Program Manager relative to the Plan.
2. "Broker" shall mean a concern that adds no material value to an item being supplied to a procuring activity or which does not take ownership or possession of or handle the item being procured with its own equipment or facilities.
3. "Certification" shall mean the qualifying process that ensures buyers and local, state and federal agencies that a particular business is an eligible MWBE which performs a commercially useful function.
4. "Commercially Useful Function" shall mean the execution by an MWBE that contracts with the JSCB, or subcontracts with another business enterprise that contracts with the JSCB, of a distinct element of the work of the contract by actually performing, managing, and supervising the work involved. A business enterprise that serves as a conduit for another business shall not be deemed to perform a commercially useful function. In determining whether an MWBE prime or subcontractor is performing a commercially useful function, factors, including but not limited to the following, will be considered:
 - a. The nature and amount of work subcontracted;
 - b. Whether the MWBE has the skill and expertise to perform work for which it has been certified, as heretofore defined;
 - c. Whether the MWBE actually performs, manages and supervises the work;
 - d. Whether the MWBE intends to purchase commodities and/or services from a non-MWBE and simply resell same to the general or prime bidder for the purpose of allowing those commodities and/or services to be counted toward assessment of a benchmark or fulfillment of a goal; and
 - e. Standard industry practices relating to the use of the second tier subcontractors. Consistent with standard industry practices, an MWBE subcontractor may enter into second tier subcontracts. If an MWBE subcontractor subcontracts a significantly greater portion of the work of its subcontract to a non-MWBE inconsistent with standard industry practices, the MWBE subcontractor shall be presumed not to be performing a commercially useful function.
5. "Compliance" shall mean the condition existing when a bidder has met the requirements of this Diversity Plan.
6. "Conduit" shall mean a business that purchases goods or services that are not normally purchased or sold as a part of its daily business from another business for the sole purpose of resale to the JSCB or a contractor doing business with the board.
7. "Contract" shall mean any binding legal obligation of the JSCB created to acquire some good and/or service from one or more bidders, which is paid for or which is to be paid for, in whole or in part, with monetary appropriations of the JSCB. In this context, the terms contracting, purchasing, and procurement are synonymous and refer to the process or processes under which the Board undertakes such acquisitions.

8. "Diversity Goals" mean the goals, including business development goals and workforce participation goals set out in this Diversity Plan.

9. "Good Faith Efforts" shall mean a documented and sincere intention to meet all of the established JSCB Diversity Goals. Good Faith Efforts shall be mandatory for all bidders.

10. "Independent" shall mean that with respect to the ownership, control and activity of an MWBE, the business shall operate separate and apart from the ownership, control or undue influence of another business owned and controlled by one or more non-MWBEs.

11. "Joint Venture" shall mean an association of two or more independent persons, partnerships, corporations (or any combination of them) formed, consistent with the laws of the State of New York, to perform one or more specific contracts limited in scope and duration; and for which purpose, the entities combined their property, capital, effort, skills, knowledge and other assets.

12. "Minority" shall mean African American(s) (a person(s) having origins in any of the indigenous sub-Saharan racial groups of Africa), Native Americans, Hispanic Americans, and Asian Americans and any other racial group(s) for which there is a legally sufficient statistical disparity indicated, and an underutilization attributable to the effects of past or present discrimination in the local industry.

13. "Minority Business Enterprise" (MBE) shall mean, for the purpose of this Diversity Plan, an independent concern which is at least 51% owned, operated and controlled by a minority who is a citizen of the United States, or a permanent resident of the United States and provides a commercially useful function, as defined herein.

14. "MWBE" shall mean, severally or collectively, a Minority Business Enterprise (MBE) and/or a Women Business Enterprise (WBE).

15. "Non-Compliance" shall mean the condition existing when a bidder has failed to meet the requirements of this Diversity Plan.

16. "Independent Compliance Officer" (ICO) shall mean the ICO who is responsible for administration of this Diversity Plan.

17. "Owned" shall mean that the minority, female, disadvantaged owner(s) possess an ownership interest of at least fifty-one percent (51%) of the business, for purposes of determining whether a business is a Minority Business Enterprise, Disadvantaged or Women Business Enterprise.

18. "Promise of Non-Discrimination" shall mean, collectively, one or more voluntary contractual affirmative promises and other promises of forbearance made by a bidder relating to the bidder's conduct occurring prior to submission of a bid as well as after award of a contract: (1) to adopt the policies of the Board relating to the participation of MWBEs in the procurement process; (2) to undertake certain affirmative good faith effort measures to ensure the maximum practicable participation by MWBEs; and (3) not to otherwise engage in discriminatory conduct against MWBEs inconsistent with said policies.

19. "Review" shall mean a hearing upon complaint filed by the ICO to determine whether a bidder has satisfactorily implemented good faith efforts to include MWBEs in the procurement process and if so, the bidder shall be deemed to be responsive.

20. "Women Business Enterprise" (WBE) shall mean, for the purpose of this Diversity Plan, an independent concern that is at least 51% owned, operated and controlled by female member(s) who are citizens of the United States or permanent residents of the United States and provides a commercially useful function, as defined herein.

C. PLAN SCOPE AND APPLICABILITY

The following categories are initially established to identify the nature and types of goods and services the JSCB is contracting for.

Category A - Construction: Includes all contracting relating to buildings, facilities and other erected structures on school projects in the Program.

Category B - Services: Encompasses the procurement of advertising, printing, non-construction repairs, janitorial services, training seminars and workshops, computer and information systems, security, shipping and mailing, microfiche and microfilm, courier, storage, travel, and consulting.

Category C - Commodities: Includes the purchase of all goods, equipment, food, office and other supplies, art, furniture and other tangible personal property not associated with under the provision of a service identified in Categories A and B.

Category D - Employment Compliance: This Diversity Plan segment ensures workforce Diversity Goals (minority and female employment goals) are met and maintained through the life of each Program.

Category E - Professional Services: This Diversity Plan segment covers: (1) professional design contracts requiring the services of licensed architects, engineers, planners and surveyors; (2) regulated professional contracts requiring the services of individuals and firms whose practices are regulated by the State of New York; (3) general consultant contracts such as program and construction management services, affirmative action services and general business services; and (4) general service contracts such as janitorial, snow removal and printing.

Independent Compliance Officer: The JSCB will hire and will retain an Independent Compliance Officer, herein referred to as ICO to administer and enforce the Diversity Plan. The ICO will be responsible for the performance of the following duties and obligations for purposes of implementing and achieving the policies and objectives of this Diversity Plan:

- a. To administer and enforce JSCB policy;
- b. To promulgate rules, regulations and procedures consistent with this Diversity Plan and publish and make public said rules, regulations and procedures for MWBE, minority and women participation.
- c. To verify MWBEs are appropriately certified;

- d. To initiate and maintain outreach plans for all MWBEs, minorities and women;
- e. To develop, maintain and make available a database of certified MWBEs;
- f. To make a recommendation regarding reasonable and market based MWBE Goals and Workforce Diversity Goals and to annually assess such goals;
- g. To pursue applicable MWBE and Workforce Diversity Goals as provided for in this Plan;
- h. To attend pre-bid, pre-award, post-bid and bid-award meetings;
- i. To receive and investigate written complaints as provided in the written complaint and post bid review sections of this Diversity Plan;
- j. To notify all parties of the right to review any decision of the ICO;
- k. To provide recommendations to the Board, Program Manager and other pertinent personnel to effectuate the policies and objectives of this Diversity Plan;
- l. To prepare and submit monthly, quarterly and annual reports;
- m. To perform other tasks necessary to fulfill the above duties and to carry out the intent of the JSCB.

D. RIGHT TO INVESTIGATE

Investigate Non-Compliance Practices: The Independent Compliance Officer shall be authorized to determine compliance by contractors with the Diversity Goals established in JSCB contracts. Such a determination of compliance or non-compliance may be based on whether the contractor is complying with goals set forth in an approved utilization plan; or the determination is consistent with the procedures or action described in the Diversity plan; or the information made available to the JSCB through monitoring, onsite inspections, progress meeting, review of payrolls or other JSCB action to provide evidence of compliance. (NYCRR 143.5)

E. MONITORING, EVALUATION AND REPORTING

ICO Authorization to Monitor: The ICO shall be authorized to collect from all contractors doing business with the JSCB information as to business ownership, supplier information, subcontractor information, and other data that reflects the race, gender, and ethnic origin of bidders, vendors, contractors and subcontractors, as well as information regarding workforce composition.

Duty to Monitor Contracting: The ICO shall continuously monitor the participation of MWBEs, minorities and women in the procurement and provision of goods and services for the JSCB. Such monitoring shall include, but is not necessarily limited to, a statistical analysis of each commodity, construction trade and professional services, financial services, employment compliance monitoring and a determination as to whether, in any such classification, there is utilization of minorities and women in a manner that is proportioned to their availability range. While this monitoring function may be performed on an ongoing, as needed basis after the completion of construction, the ICO will provide

monthly, quarterly and annual written reports to the JSCB during preconstruction and construction phase and post-construction phase.

Reporting: The ICO will gather statistical data and report to the JSCB a summary of the purchases and contracts placed with MWBEs for the period and the relative percentage to the total of purchases and contracts for that period. All reports submitted shall specify the percentage of MWBEs that are minority and/or women-owned businesses as defined herein, with each minority category reported separately. Payments made to non-certified minority and women-owned businesses and other MWBEs shall be included as a separate set of figures for purposes of tabulating the total contract dollars going to minority and women-owned businesses.

The reports will emphasize quantity and quality of MWBE involvement by dollar volume. Reporting will serve the dual purpose of giving credit where due and highlighting areas needing additional effort. Monthly reports to the JSCB shall also include information relevant to efforts to employ minorities and women and information relevant to purchasing efforts based on ethnicity and gender.

F. MWBE ELIGIBILITY

General Eligibility: Generally, any business enterprise certified by a New York State recognized certifying agency as an MWBE as earlier defined under this Diversity Plan, and as determined to be eligible and qualified as an MWBE by the JSCB, is eligible to participate in the Program. All MWBEs so recognized as qualified and eligible shall be eligible to participate as an MWBE in the Program.

Certification: Firms seeking to participate as an MWBE in the Program must be certified as an MWBE by a New York State recognized certifying agency. This screening mechanism for certification assures that the interested MWBEs have the property ownership, size, control and management to meet the eligibility requirements of the JSCB. However, upon good cause, the JSCB may determine that despite certification from a New York State recognized certifying agency that the firm does not meet the requirements of an MWBE that is entitled to participate as an MWBE in the Program.

G. PROVISIONS RELATING TO MWBE

Establishment of Annual Participation Goals: Based on the historical underutilization of MBE/WBEs, there is a compelling interest within the City of Yonkers & Westchester County to establish goals. In fulfillment of the policy to promote equal business opportunity with the JSCB, the JSCB will establish MWBE goals for all sub-categories. See NYCRR Section 141.2 and Section 143.2. The goals shall be subject to an annual review.

Contractors and Subcontractors Must Meet Participation Goals: It is agreed that all prime contractors and subcontractors, who have been awarded contracts for work covered by this Agreement shall be bound to meet all established Diversity Goals. They shall evidence their acceptance of this provision in the Letter of Intent to Perform. This Agreement shall be made a part of the contract and incorporated by reference into contract documents.

Project Goals: In addition to the annual overall Diversity Plan goals and category goals, the goals for each project will be established and reported.

Notice of Bid Opportunities: The ICO and all bidders shall give notice of bid opportunities for each contract to all known available MWBEs with capabilities consistent with the requirements of the specific contract.

Consideration of Goals in Bid Evaluation: Where the JSCB establishes goals, the inclusion of underutilized MWBEs shall become an additional factor considered in the evaluation of bids submitted by contractors, in addition to, but not limited to all other generally accepted considerations.

Annual Review: The Diversity Goals set forth in this Diversity Plan shall be subject to an annual review.

Assessment of Goals: All total contract dollars awarded to minorities/women-owned businesses, whether payments are made to non-certified MBEs and WBEs, or certified MWBEs, shall count toward the calculation of whether minority/women participation reflects the goal in a designated category. For the purposes of state reporting only those dollars paid to certified MWBEs will be counted.

H. COUNTING OF MWBE PARTICIPATION

Types of participation that may be counted towards the goal:

- (1) The total dollar value of the contract may be counted toward the specified goal. This includes reasonable fees charged for professional services, legal counsel and financial consultants.
- (2) The actual portion of the MWBE participation in a joint venture is counted toward the specified goal.

In the event that goals are established, all bidders, including MWBE bidders, shall make good faith efforts to attain goals through all tiers of participation (all subcontractor work).

1. **Prime Contractors:** A prime contractor may subcontract portions of its contract that are consistent with industry standards. However, should a prime contractor subcontract a greater portion of the project than is consistent with industry standards, then the MWBE will not have performed a commercially useful function as defined herein. Therefore, such participation by MWBEs will not be counted towards any goal. Prime contractors are strongly encouraged to consider subcontracting in a wide range of industry sub-trade categories. The participation by brokers shall not be considered under this Program.
2. **Subcontractor Participation:** Where a prime contractor utilizes one or more subcontractors or sub-subcontractors to attain any goal(s) for an underutilized subcategory, the prime contractor may count said subcontractor or sub-subcontractor work toward goals. In no way shall subcontractors' or sub-subcontractors' work or dollar amount be construed to count toward said goal more than once. Only expenditures to MWBE subcontractors that perform a commercially useful function in the work of the project or contract may be counted. An MWBE prime, subcontractor, or sub-subcontractor is considered to perform a commercially useful function when it is responsible for execution of a distinct element of the work of a contract and carries out its responsibilities by actually performing, managing and supervising the work involved.

- 3. Supplier Participation:** Where a prime contractor utilizes suppliers to satisfy the goal(s) in whole or in part, the MWBE suppliers must perform a commercially useful function. Participation may be approved upon review of the following factors:
- a. the nature and amount of supplies to be furnished;
 - b. whether the MWBE is a manufacturer, wholesaler or distributor of the supplies and has the capabilities to deliver the goods in accordance with its certification;
 - c. whether the MWBE actually performs, manages and supervises the work to furnish the supplies;
 - d. whether the MWBE intends to purchase supplies from a non-MWBE and simply resell same to the general or prime bidder for the purpose of allowing those supplies to be counted towards fulfillment of the goal(s); and
 - e. Fifty percent (50%) of the contract amount for suppliers and vendors shall count towards the goal on construction contracts.
- 4. Joint Venture Participation:** Where bidders engage in a joint venture to meet a goal, the bidder shall demonstrate that the MWBE joint venturer's participation meets the standards for a commercially useful function, as herein defined. The ICO shall review and approve all contractual agreements and other supporting documentation to determine the percentage of MWBE participation resulting from the joint venture that may be credited toward any applicable goals of the project; and shall determine same based on the following factors:
- a. the initial capital investment of each venture partner;
 - b. the proportional allocation of profits and losses to each venture partner;
 - c. the sharing of the right to control the ownership and management of the joint venture;
 - d. actual participation of the venture partners in the performance of work under the project or contract;
 - e. the method of and responsibility for accounting;
 - f. the method by which disputes are resolved; and
 - g. other pertinent factors of the joint venture.

The degree to which any goals have been attained by joint ventures between MWBE and non-MWBE firms, shall be calculated as follows:

1. A joint venture consisting of an MWBE and non-MWBE firm functioning as a prime contractor will be credited with minority and/or gender participation on the basis of the percentage of the dollar amount of the work to be performed by the minority and/or women-owned MWBE.

2. In joint venture bids in which all joint venture participants are MWBEs, the joint venture will be credited with minority and/or female participation for that portion of the dollar amount of the contract which minority and/or women-owned MWBEs perform and that portion subcontracted to minority and/or women-owned firms.

3. In joint venture bids, bidders will receive credit toward the goal for the dollar amount purchased from minority and/or women-owned MWBE suppliers. However, where the supplier is the manufacturer of the product supplied, bidders will receive credit for 50% of the dollar amount of the supply contract.

I. REQUIREMENTS OF CONTRACTORS

Contractor's Utilization Plan: At the time of bid tender each bidder shall be required to submit to the ICO a completed Contractor Utilization Plan. This state form will satisfy the requirement that utilization plans are submitted. Pursuant to NYCRR Section 143.4, the ICO shall review such utilization plan and issue a written notice of acceptance or deficiency. Any deficiency must be cured within seven days.

Promise of Non-Discrimination: At the time of bid tender each bidder shall be required to submit to the ICO a duly-executed and attested Promise of Non-Discrimination, enforceable by law, which shall contain the following provisions. The bidder voluntarily agrees:

1. To adopt the policies of the JSCB relating to equal opportunity in contracting on projects and contracts funded, whole or in part, with monetary appropriations of the JSCB;
2. To undertake certain good faith efforts as set forth herein to attain the maximum practicable participation of MWBEs on said projects and contracts;
3. Not to otherwise engage in discriminatory conduct against MWBEs.
4. That the Promise of Non-Discrimination shall be continuing in nature and shall remain in full force and effect without interruption;
5. That the Promise of Non-Discrimination is made a part of the contract and incorporated by reference into. The failure of the bidder to uphold the promises of non-discrimination shall constitute a material breach of contract. The JSCB may declare the contract in default and may exercise any and all applicable rights and remedies, including but not limited to, cancellation of the contract, termination of the contract, rejection of bids for future JSCB contracts, and withholding and/or forfeiture of compensation due and owing on a contract.

MWBE Assurance Statement: At the time of bid tender, each bidder shall be required to submit to the ICO an Assurance Statement. This statement shall include all MWBE subcontractor's names, the work the MWBE will perform, the dollar value of the project, percentage of total bid amount attributable to MWBE work, and a statement of any goal.

Letter of Intent to Perform as an MWBE Subcontractor/Joint Venture: All apparent successful bidders who plan to utilize an MWBE subcontractor or engage in a joint venture with an MWBE shall be required to submit to the ICO a letter of intent signed by both the MWBE and bidder. This form is to be completed and submitted by the end of the second business day following notice of award of contract.

The MWBE shall state on this form whether it is a sole proprietorship, individual, a corporation, a partnership, or a joint venture.

Failure on the part of a bidder to submit the Promise of Non-Discrimination, MWBE Assurance Statement, and the Letter of Intent to Perform as required shall render the bid non-responsive. The Promise of Non-Discrimination, MWBE Assurance Statement and Letter of Intent to Perform are attached hereto.

J. GOOD FAITH EFFORTS

Mandatory Good Faith Efforts: Every bidder shall submit with the bid evidence of Good Faith Efforts to meet the Diversity Goals of this Diversity Plan in the form of a checklist. A showing of Good Faith Efforts shall be mandatory for all bidders in construction, commodities and professional services.

With respect to the Business Development/MWBE goals set forth in this Diversity Plan, Good Faith Efforts shall include, at a minimum, the following:

1. Delivery of written notice to the following:

- a. at least seven (7) available certified MWBEs whose names, addresses, and telephone numbers are provided by the ICO to all bidders for each potential subcontracting or supply category in the Contract; and
- b. all MWBEs which requested information on the Contract.

2. The written notice must contain:

- a. Adequate information about the plans, specifications, and relevant terms and conditions of the Contract and about the work to be subcontracted to or the goods to be obtained from subcontractors and suppliers;
- b. A contact person knowledgeable of the project documents within the bidder's office to answer questions;
- c. Information as to the bidder's bonding requirements, the procedure for obtaining any needed bond, and the name and telephone number of one or more acceptable surety companies to contact;
- d. The last date and time for receipt by bidder of MWBE bids or price quotations.

3. Attendance at any special pre-bid meeting called to inform MWBEs of subcontracting or supply opportunities.

4. Division of the contract, in accordance with normal industry practice, into small, economically feasible segments that could be performed by an MWBE. Under no circumstances, however, shall a bidder be required to segment work solely for the purpose of utilizing MWBE participants as subcontractors where

such segmentation is not in accordance with common and accepted industry practices relating to the utilization of other firms as subcontractors.

5. Providing a written explanation to the ICO for why any MWBE considered for any portion of the work was not given the work, unless another MWBE is accepted for the same work, including the name of the non-MWBE firm proposed to be given the subcontract or supply agreement. Records of all MWBEs' price quotations and the successful non-MWBEs' price quotations should be provided to the ICO where appropriate. When price competitiveness is not the reason for the rejection, a written rejection notice including the reason for the rejection shall be sent to the rejected MWBE.

6. Providing a non-discriminatory work site. Bidder shall ensure and maintain a work environment free of harassment, intimidation and coercion at all construction sites, offices and other facilities at which the bidder's employees are assigned to work. The contractor shall specifically ensure that all labor supervisors, superintendents, and other on-site supervisory personnel are aware of and carry out the bidder's obligation to maintain a non-discriminatory work environment.

7. Reporting improper conduct and all known violations of this Diversity Plan.

Additional Good Faith Efforts: In addition to, but not in lieu of the above mandatory minimum good faith efforts required under this Diversity Plan, a bidder at its option may also make a showing of good faith by providing evidence that it performed the following tasks to encourage and obtain the maximum practicable participation of MWBEs:

1. Soliciting specific individual MWBEs whose availability as potential sources of goods or services can be reasonably ascertained. This measure includes the sending of letters or making other personal contacts with specific certified MWBEs including those with whom the bidder has contracted with in the past as well as other MWBEs with whom the bidder may be unfamiliar, but whose identities can be ascertained from a Directory of Certified MWBEs maintained by the ICO.

2. Sending letters or making other personal contacts with other minority and women business enterprise programs as well as private minority trade associations and programs known to publicize contracting and procurement opportunities for the benefit of their respective participants and/or members. Such contacts shall be relevant to the JSCB bid under consideration and the type of minority and/or women-owned business needed; and shall provide the same information required by a contractor or vendor to effectuate direct contacts with MWBEs.

3. Advertising in publications of general circulation in the Yonkers area, trade publications that are otherwise focused or marketed to a minority and/or woman business enterprise. The business must be owned and operated by them not less than twenty (20) days prior to the date bids are due. The publication or media shall be one which reasonably covers the metropolitan area. The advertisement shall identify and describe the specific subcontracting or other opportunity in reasonable detail, and shall state the MWBE goal(s) applying thereto.

4. Conducting follow-up of initial solicitations of interest by contacting MWBEs to determine, with certainty, whether these firms are interested.

5. Providing reasonable assistance to an otherwise qualified MWBE in need of equipment, supplies, bonding, letters of credit and/or insurance.

6. Providing equal opportunity to MWBEs when replacing non-performing MWBEs. If an MWBE subcontractor or supplier fails to perform successfully, the bidder must provide other MWBEs an equal opportunity to replace the non-performing subcontractor or supplier; and shall exercise the same good faith affirmative action efforts to secure the replacement.

With respect to Workforce Diversity Goals:

1. The contractor shall supply written documentation of its efforts to recruit/hire minorities and women, including:

- a. communications with the appropriate building trades;
- b. communications with training programs; and
- c. communications with other employment agencies.

Evaluation of Good Faith Efforts: In order to assure that bidders comply with the JSCB's Diversity Plan, successful bidders must demonstrate good faith efforts. In evaluating good faith efforts, the ICO will determine whether the apparent low bidder has made reasonable efforts to obtain MWBE/minority/women participation. The ICO may evaluate not only the different kinds of efforts made by a bidder, but also the quantity and intensity of those efforts. The bidder may submit additional documentation to the ICO for consideration in the evaluation of the bidder's good faith efforts. See NYCRR Section 143.8.

Required Documentation: To demonstrate compliance with the good faith requirements of this Plan, bidders shall keep detailed records of all correspondence and responses thereto, logs of all telephone calls made and received regarding the project or contract, copies of advertisements in publications and other media, and other relevant papers as required by this Diversity Plan for a minimum period of three (3) years.

Award of Contract: The JSCB in accordance with the applicable law retains the right to determine the action to be taken on the contract. The JSCB reserves the right to reject bids and perform project re-bids for the purpose of attaining its Diversity Goals, in accordance with applicable law.

Contractors' Post-Award Reporting and Maintenance of Records: Successful bidders awarded contracts incorporating MWBE participation must submit reports by the designated date set forth by the Program Manager and the ICO. These reports shall summarize the number and dollar amounts of payments made during the terms of the contract to MWBEs. Such reporting shall count payments to MWBEs separately.

K. WRITTEN COMPLAINT AND POST-BID REVIEW

Any bidder allegedly aggrieved by the provisions of this Diversity Plan may seek review of any written complaint to the ICO and Program Manager.

Consideration of Bids: The ICO shall evaluate the apparent low bidder's good faith efforts for compliance. Upon a determination of compliance by the apparent low bidder, the ICO shall forward the

apparent low bidder's bid to the Program Manager as the recommended low bid. If there is an issue of non-compliance within the meaning of this Diversity Plan, or for any other written complaint alleging any violations or non-compliance with this Diversity Plan, the ICO shall notify the affected party in writing and by registered mail (hereinafter "Notice of Non-Compliance Review") setting forth with particularity the reasons for the review and scheduling a Post-Bid Review Conference.

1. **Post-Bid Review Conference:** A Post-Bid Review Conference shall be held with the ICO, the apparent low bidder, and if applicable, the Program Manager.

2. **Declaration of Non-Responsiveness:** Following the Post-Bid Review conference the ICO may make a recommendation to the JSCB that an apparent low bidder's bid be rejected as non-responsive for failing to demonstrate Good Faith Efforts or any other provisions of this Plan, as determined by the ICO.

L. SANCTIONS AND PENALTIES FOR NON-COMPLIANCE

In evaluating bids and proposals solicited during the procurement process, the lowest price is one of several factors that will be used in the contract award evaluation process. The Program Manager will be concerned with responsive and responsible bidders who can provide quality goods and services. Additionally, it is expected that all firms will exercise Good Faith Efforts in seeking to maximize the use of available MWBEs in commercially viable ways, and the failure of a bidder to demonstrate the mandatory Good Faith Efforts to include MWBEs in the procurement process will be considered in the award of the contract.

JSCB to Impose Sanctions/Penalties: The JSCB, in consultation with the ICO, shall have the authority and power to enforce the provisions of this Diversity Plan. Failure by a bidder to comply with the requirements shall subject the non-complying party to administrative sanctions, after the opportunity to attend a hearing before a panel selected by the JSCB Board for that purpose. In addition, a violation of this Diversity Plan shall constitute a material breach of contract enforceable by law or in equity as will all other contract provisions, including the imposition of penalties. The following sanctions and penalties are established for the enforcement of this Plan:

1. **Declaration of Non-Responsiveness:** In addition to standard factors in bid evaluation, the JSCB may declare a bid non-responsive where it is determined that a bidder: Has not filed with the JSCB a duly executed "Contractor's Utilization Plan" or "Promise of Non-Discrimination"; or has failed to implement Good Faith Efforts.

2. **Cancellation of Contract:** The JSCB may declare a contract as null and void where, after such contract has been awarded, if an investigation determines that the bidder's Workforce or MWBE utilization documents contain false, fictitious, or fraudulent information.

3. **Rejection of Future Bids:** The JSCB may reject any or all future bids of a bidder until such time as the bidder shall have demonstrated that it is or shall come into compliance.

4. **Withholding Payment, Limited Suspension and Debarment:** For falsifications, misrepresentations, or engaging in subterfuge to obtain a contract, the JSCB may remove a bidder from its list of pre-qualified or otherwise eligible firms entitled to do business with the JSCB for a period not to exceed one (1) year or withhold payment after notice and opportunity for due process in the form of a hearing before a panel selected by the JSCB for that purpose.

5. Permanent Debarment: For repeated violations, the JSCB may remove a bidder from its list of pre-qualified or otherwise eligible firms entitled to do business with the JSCB, in accordance with applicable law.

M. SANCTIONS GUIDELINES

Guidelines for Imposition of Sanctions: The sole authority for imposition of sanctions shall lie with the JSCB, in accordance with applicable law.

1. **General:** No suspension shall be imposed by the JSCB except upon evidence of specific conduct on the part of an MWBE or other contractor that is inconsistent with or in direct contravention of the applicable provisions of this Diversity Plan. Furthermore, the imposition and enforcement of sanctions shall be consistent with applicable state and federal law.

2. **Severity of Sanctions:** In determining the length of any suspension, the JSCB shall consider the following factors:

- a. Whether the failure to comply with applicable requirements involved intentional conduct or, alternatively, may be reasonably concluded to have resulted from a misunderstanding on the part of the contractor or MWBE of the duties imposed on them by this Program;
- b. The number of specific incidences of failure by the contractor or MWBE to comply;
- c. Whether the contractor or MWBE has been previously suspended;
- d. Whether the contractor or MWBE has failed or refused to provide the JSCB or the ICO with any information required by this Diversity Plan.
- e. Whether the contractor or MWBE has materially misrepresented any applicable facts in any filing or communication to the JSCB or the ICO; and
- f. Whether any subsequent restructuring of the subject business or other action has been undertaken to cure the deficiencies in meeting applicable requirements.

3. **Length of Suspension:** Suspensions may be for any length of time not to exceed two (2) years. Suspensions in excess of one year shall be reserved for cases involving intentional or fraudulent misrepresentation or concealment of material facts, multiple acts in contravention of applicable requirements, cases where the contractor or MWBE has been previously suspended, or other similarly egregious conduct.

N. UNDERUTILIZATION REMEDIES

Bond Requirements: Bid bonds are usually required on large projects. The ability to qualify for bonds is often a problem for MWBEs. Therefore, these firms often miss out on substantial business opportunities. As an initiative to enhance minority and women business participation, and small business participation, the JSCB may, in its sole discretion, waive payment and performance bond requirements on certain service contracts where health and safety are not an issue.

Prompt Resolution of Invoice Disputes: MWBEs can be financially impacted if they do not receive timely notification of errors or questions regarding an invoice. Often the corrected invoice does not get included in the original submittal period but instead is submitted in a later submittal period. If a prime disagrees with an invoice submitted by an MWBE, the prime has three (3) business days to notify the MWBE of any questions. The MWBE shall then have three to five (5) business days to resubmit a corrected invoice. This invoice shall be paid within the original scheduled draw period.

Prompt Payment Program: MWBEs are placed in substantial financial risk when they do not receive draws in a timely manner. The irregularities of payment affect their ability to perform on the specific contract and other ongoing contracts. In many cases the prime has been paid for the work completed by the MWBE. To remedy this problem, the ICO will be notified when the prime receives a draw. The prime must pay the subcontractor in a timely fashion. If the firm does not receive payment in a timely fashion, the ICO, the prime, subcontractor and Program Manager shall meet. If the payment was withheld without reason, the prime shall be required to pay a penalty in the amount of three times the prime interest rate. Additional penalties may be imposed in the event the prime exhibits any negative action toward the MWBE as reported to the ICO by the MWBE.

Outreach Program The MWBE Outreach Program will be set up by the ICO to notify the entire community of contracts and professional services opportunities available to them. The procedures within this program will reinforce the JSCB commitment to do business with MWBEs. In order for this program to be accomplished, a constant saturation effort should be made to pursue all capable, competent, certified, qualified and prepared MWBEs. Notification of the Outreach Program will be forwarded, on a quarterly basis and when updating is necessary, to all media in the Westchester County area focused or marketed to MWBEs. Publications with a known MWBE audience will be targeted. The ICO will actively communicate with local advocacy groups to keep them abreast of the Outreach Program.

O. HIRING AND APPRENTICESHIP PROGRAM

Apprenticeship Programs: The JSCB will require apprentice training programs mandated by the Act. Such programs shall be registered by the Department of Labor. All requirements set forth in the Act for such programs shall be met. The JSCB will promote interest in such apprenticeship programs throughout the community.

P. SEVERABILITY

If any of the provisions set forth in this Program or any section, subsection, paragraph, sentence, clause, phrase, or word thereof shall be found to be invalid, illegal or unenforceable for any reason, the application of the remainder of this Program shall not be affected by such invalidity.

Q. AMENDMENTS

This Diversity Plan is subject to periodic review by the JSCB and may be amended, at any time, in the discretion of the JSCB. To the extent that anything contained in this Diversity Plan conflicts with the Act, or any other applicable law, the provisions of the Act or such applicable law shall control.

**Diversity Plan for Construction Pursuant to Phase I of the
Comprehensive Joint Schools
Construction and Modernization Plan**

RIDER #1

Page 6 Section 1. (i): New York State certified MBE and WBE firms to replace City of Yonkers certified firms.

Page 7 Section 2. (c.): Replace paragraph with:

C. **Supplier Participation:** Where a prime contractor utilizes suppliers to satisfy the goal(s) in whole or in part, the M/WBE suppliers must perform a commercially useful function. Participation may be approved upon review of the following factors:

1. the nature and amount of supplies to be furnished;
2. whether the M/WBE is a manufacturer, wholesaler or distributor of the supplies and has the capabilities to deliver the goods in accordance with its certification;
3. whether the M/WBE actually performs, manages and supervises the work to furnish the supplies;
4. whether the M/WBE intends to purchase supplies from a non-M/WBE and simply resell same to the general or prime bidder for the purpose of allowing those supplies to be counted towards fulfillment of the goal(s);
- e. Fifty percent (50%) of the contract amount for suppliers and vendors shall count towards the goal on construction contracts.

Page 9, #8 & #9: Replace with:

8. Once all work has been completed on a contract and prior to close out, the Prime Contractor will submit Form B's to the CCO & ICO stating the total amount actually paid to the MWBE along with corresponding proof of payment. A separate Form B is needed for each MWBE participating in the contract. Each Form B must be signed by both the prime contractor and the MWBE firm.

9. The Independent Compliance Officer shall review all Form B's for completeness and accuracy.

Page 18 Section (J) 1- a.: Insert "all of the available" to replace "at least (7) available".

The following additions, substitutions, or clarifications are extracted from the (5) Bid Addenda issued with this project during bidding. This insert is intended to summarize addendum information relevant to this specification section. See Bid Addenda issued by the City of Yonkers for complete contract document changes.

Bid Addendum No. 3:

Remove “DRAFT” watermark from AIA Document A305. See attachment.

Remove “DRAFT” watermark from Exhibit A to AIA Document A305. See attachment.

Remove “DRAFT” watermark from Exhibit B to AIA Document A305. See attachment.

Remove “DRAFT” watermark from Exhibit C to AIA Document A305. See attachment.

Remove “DRAFT” watermark from Exhibit D to AIA Document A305. See attachment.

Remove “DRAFT” watermark from Exhibit E to AIA Document A305. See attachment.

AIA Documents that are not included in this Addendum, and are marked with the “DRAFT” watermark, are to be considered as final documents, not draft documents. These forms include, but not limited to, AIA A132 Standard Form of Agreement Between Owner and Contractor, A232 General Conditions of the Contract for Construction, A312 Performance Bond and A312 Payment Bond.

 **AIA[®] Document A305™ – 2020****Contractor's Qualification Statement**

THE PARTIES SHOULD EXECUTE A SEPARATE CONFIDENTIALITY AGREEMENT IF THEY INTEND FOR ANY OF THE INFORMATION IN THIS A305-2020 TO BE HELD CONFIDENTIAL.

SUBMITTED BY: _____ **SUBMITTED TO:** _____
(*Organization name and address.*) (Organization name and address.)

TYPE OF WORK TYPICALLY PERFORMED

(*Indicate the type of work your organization typically performs, such as general contracting, construction manager as constructor services, HVAC contracting, electrical contracting, plumbing contracting, or other.*)

THIS CONTRACTOR'S QUALIFICATION STATEMENT INCLUDES THE FOLLOWING:

(*Check all that apply.*)

- Exhibit A – General Information
- Exhibit B – Financial and Performance Information
- Exhibit C – Project-Specific Information
- Exhibit D – Past Project Experience
- Exhibit E – Past Project Experience (Continued)

CONTRACTOR CERTIFICATION

The undersigned certifies under oath that the information provided in this Contractor's Qualification Statement is true and sufficiently complete so as not to be misleading.

Organization's Authorized Representative
Signature

Date

Printed Name and Title

NOTARY

State of:

County of:

Signed and sworn to before me this ____ day of _____

Notary Signature

My commission expires: _____

ADDITIONS AND DELETIONS:

The author of this document has added information needed for its completion. The author may also have revised the text of the original AIA standard form. An *Additions and Deletions Report* that notes added information as well as revisions to the standard form text is available from the author and should be reviewed. A vertical line in the left margin of this document indicates where the author has added necessary information and where the author has added to or deleted from the original AIA text.

This document has important legal consequences. Consultation with an attorney is encouraged with respect to its completion or modification.



AIA[®] Document A305™ – 2020 Exhibit A

General Information

This Exhibit is part of the Contractor’s Qualification Statement, submitted by _____ and dated the _____ day of _____ in the year _____.
(In words, indicate day, month and year.)

§ A.1 ORGANIZATION

§ A.1.1 Name and Location

§ A.1.1.1 Identify the full legal name of your organization.

§ A.1.1.2 List all other names under which your organization currently does business and, for each name, identify jurisdictions in which it is registered to do business under that trade name.

§ A.1.1.3 List all prior names under which your organization has operated and, for each name, indicate the date range and jurisdiction in which it was used.

§ A.1.1.4 Identify the address of your organization’s principal place of business and list all office locations out of which your organization conducts business. If your organization has multiple offices, you may attach an exhibit or refer to a website.

§ A.1.2 Legal Status

§ A.1.2.1 Identify the legal status under which your organization does business, such as sole proprietorship, partnership, corporation, limited liability corporation, joint venture, or other.

- .1 If your organization is a corporation, identify the state in which it is incorporated, the date of incorporation, and its four highest-ranking corporate officers and their titles, as applicable.
- .2 If your organization is a partnership, identify its partners and its date of organization.
- .3 If your organization is individually owned, identify its owner and date of organization.

ADDITIONS AND DELETIONS:

The author of this document has added information needed for its completion. The author may also have revised the text of the original AIA standard form. An *Additions and Deletions Report* that notes added information as well as revisions to the standard form text is available from the author and should be reviewed. A vertical line in the left margin of this document indicates where the author has added necessary information and where the author has added to or deleted from the original AIA text.

This document has important legal consequences. Consultation with an attorney is encouraged with respect to its completion or modification.

- .4 If the form of your organization is other than those listed above, describe it and identify its individual leaders:

§ A.1.2.2 Does your organization own, in whole or in part, any other construction-related businesses? If so, identify and describe those businesses and specify percentage of ownership.

§ A.1.3 Other Information

§ A.1.3.1 How many years has your organization been in business?

§ A.1.3.2 How many full-time employees work for your organization?

§ A.1.3.3 List your North American Industry Classification System (NAICS) codes and titles. Specify which is your primary NAICS code.

§ A.1.3.4 Indicate whether your organization is certified as a governmentally recognized special business class, such as a minority business enterprise, woman business enterprise, service disabled veteran owned small business, woman owned small business, small business in a HUBZone, or a small disadvantaged business in the 8(a) Business Development Program. For each, identify the certifying authority and indicate jurisdictions to which such certification applies.

§ A.2 EXPERIENCE

§ A.2.1 Complete Exhibit D to describe up to four projects, either completed or in progress, that are representative of your organization's experience and capabilities.

§ A.2.2 State your organization's total dollar value of work currently under contract.

§ A.2.3 Of the amount stated in Section A.2.2, state the dollar value of work that remains to be completed:

§ A.2.4 State your organization's average annual dollar value of construction work performed during the last five years.

§ A.3 CAPABILITIES

§ A.3.1 List the categories of work that your organization typically self-performs.

§ A.3.2 Identify qualities, accreditations, services, skills, or personnel that you believe differentiate your organization from others.

§ A.3.3 Does your organization provide design collaboration or pre-construction services? If so, describe those services.

§ A.3.4 Does your organization use building information modeling (BIM)? If so, describe how your organization uses BIM and identify BIM software that your organization regularly uses.

§ A.3.5 Does your organization use a project management information system? If so, identify that system.

§ A.4 REFERENCES

§ A.4.1 Identify three client references:

(Insert name, organization, and contact information)

§ A.4.2 Identify three architect references:

(Insert name, organization, and contact information)

§ A.4.3 Identify one bank reference:

(Insert name, organization, and contact information)

§ A.4.4 Identify three subcontractor or other trade references:

(Insert name, organization, and contact information)



AIA[®] Document A305[™] – 2020 Exhibit B

Financial and Performance Information

This Exhibit is part of the Contractor’s Qualification Statement, submitted by _____ and dated the _____ day of _____ in the year _____.
(In words, indicate day, month and year.)

§ B.1 FINANCIAL

§ B.1.1 Federal tax identification number:

§ B.1.2 Attach financial statements for the last three years prepared in accordance with Generally Accepted Accounting Principles, including your organization’s latest balance sheet and income statement. Also, indicate the name and contact information of the firm that prepared each financial statement.

§ B.1.3 Has your organization, its parent, or a subsidiary, affiliate, or other entity having common ownership or management, been the subject of any bankruptcy proceeding within the last ten years?

§ B.1.4 Identify your organization’s preferred credit rating agency and identification information.

(Identify rating agency, such as Dun and Bradstreet or Equifax, and insert your organization’s identification number or other method of searching your organization’s credit rating with such agency.)

§ B.2 DISPUTES AND DISCIPLINARY ACTIONS

§ B.2.1 Are there any pending or outstanding judgments, arbitration proceedings, bond claims, or lawsuits against your organization, its parent, or a subsidiary, affiliate, or other entity having common ownership or management, or any of the individuals listed in Exhibit A, Section 1.2, in which the amount in dispute is more than \$75,000?

(If the answer is yes, provide an explanation.)

§ B.2.2 In the last five years has your organization, its parent, or a subsidiary, affiliate, or other entity having common ownership or management:

(If the answer to any of the questions below is yes, provide an explanation.)

.1 _____ failed to complete work awarded to it?

.2 _____ been terminated for any reason except for an owners’ convenience?

ADDITIONS AND DELETIONS:

The author of this document has added information needed for its completion. The author may also have revised the text of the original AIA standard form. An *Additions and Deletions Report* that notes added information as well as revisions to the standard form text is available from the author and should be reviewed. A vertical line in the left margin of this document indicates where the author has added necessary information and where the author has added to or deleted from the original AIA text.

This document has important legal consequences. Consultation with an attorney is encouraged with respect to its completion or modification.

.3 had any judgments, settlements, or awards pertaining to a construction project in which your organization was responsible for more than \$75,000?

.4 filed any lawsuits or requested arbitration regarding a construction project?

§ B.2.3 In the last five years, has your organization, its parent, or a subsidiary, affiliate, or other entity having common ownership or management; or any of the individuals listed in Exhibit A Section 1.2:
(If the answer to any of the questions below is yes, provide an explanation.)

.1 been convicted of, or indicted for, a business-related crime?

.2 had any business or professional license subjected to disciplinary action?

.3 been penalized or fined by a state or federal environmental agency?



AIA[®] Document A305™ – 2020 Exhibit C

Project Specific Information

This Exhibit is part of the Contractor’s Qualification Statement, submitted by _____ and dated the _____ day of _____ in the year _____.
(In words, indicate day, month and year.)

PROJECT:

(Name and location or address.)

Community School 35
121 McLean Avenue,
Yonkers, NY 10705

CONTRACTOR’S PROJECT OFFICE:

(Identify the office out of which the contractor proposes to perform the work for the Project.)

TYPE OF WORK SOUGHT

(Indicate the type of work you are seeking for this Project, such as general contracting, construction manager as constructor, design-build, HVAC subcontracting, electrical subcontracting, plumbing subcontracting, etc.)

CONFLICT OF INTEREST

Describe any conflict of interest your organization, its parent, or a subsidiary, affiliate, or other entity having common ownership or management, or any of the individuals listed in Exhibit A Section 1.2, may have regarding this Project.

§ C.1 PERFORMANCE OF THE WORK

§ C.1.1 When was the Contractor’s Project Office established?

§ C.1.2 How many full-time field and office staff are respectively employed at the Contractor’s Project Office?

§ C.1.3 List the business license and contractor license or registration numbers for the Contractor’s Project Office that pertain to the Project.

§ C.1.4 Identify key personnel from your organization who will be meaningfully involved with work on this Project and indicate (1) their position on the Project team, (2) their office location, (3) their expertise and experience, and (4) projects similar to the Project on which they have worked.

ADDITIONS AND DELETIONS:

The author of this document has added information needed for its completion. The author may also have revised the text of the original AIA standard form. An *Additions and Deletions Report* that notes added information as well as revisions to the standard form text is available from the author and should be reviewed. A vertical line in the left margin of this document indicates where the author has added necessary information and where the author has added to or deleted from the original AIA text.

This document has important legal consequences. Consultation with an attorney is encouraged with respect to its completion or modification.

§ C.1.5 Identify portions of work that you intend to self-perform on this Project.

§ C.1.6 To the extent known, list the subcontractors you intend to use for major portions of work on the Project.

§ C.2 EXPERIENCE RELATED TO THE PROJECT

§ C.2.1 Complete Exhibit D to describe up to four projects performed by the Contractor's Project Office, either completed or in progress, that are relevant to this Project, such as projects in a similar geographic area or of similar project type. If you have already completed Exhibit D, but want to provide further examples of projects that are relevant to this Project, you may complete Exhibit E.

§ C.2.2 State the total dollar value of work currently under contract at the Contractor's Project Office:

§ C.2.3 Of the amount stated in Section C.2.2, state the dollar value of work that remains to be completed:

§ C.2.4 State the average annual dollar value of construction work performed by the Contractor's Project Office during the last five years.

§ C.2.5 List the total number of projects the Contractor's Project Office has completed in the last five years and state the dollar value of the largest contract the Contractor's Project Office has completed during that time.

§ C.3 SAFETY PROGRAM AND RECORD

§ C.3.1 Does the Contractor's Project Office have a written safety program?

§ C.3.2 List all safety-related citations and penalties the Contractor's Project Office has received in the last three years.

§ C.3.3 Attach the Contractor's Project Office's OSHA 300a Summary of Work-Related Injuries and Illnesses form for the last three years.

§ C.3.4 Attach a copy of your insurance agent's verification letter for your organization's current workers' compensation experience modification rate and rates for the last three years.

§ C.4 INSURANCE

§ C.4.1 Attach current certificates of insurance for your commercial general liability policy, umbrella insurance policy, and professional liability insurance policy, if any. Identify deductibles or self-insured retentions for your commercial general liability policy.

§ C.4.2 If requested, will your organization be able to provide property insurance for the Project written on a builder's risk "all-risks" completed value or equivalent policy form and sufficient to cover the total value of the entire Project on a replacement cost basis?

§ C.4.3 Does your commercial general liability policy contain any exclusions or restrictions of coverage that are prohibited in the Owner's Insurance Requirements? If so, identify.

§ C.5 SURETY

§ C.5.1 If requested, will your organization be able to provide a performance and payment bond for this Project?

§ C.5.2 Surety company name:

§ C.5.3 Surety agent name and contact information:

§ C.5.4 Total bonding capacity:

§ C.5.5 Available bonding capacity as of the date of this qualification statement:



AIA[®]

Document A305™ – 2020 Exhibit D

Contractor's Past Project Experience

	1	2	3	4
PROJECT NAME				
PROJECT LOCATION				
PROJECT TYPE				
OWNER				
ARCHITECT				
CONTRACTOR'S PROJECT EXECUTIVE				
KEY PERSONNEL (include titles)				
PROJECT DETAILS	Contract Amount Completion Date % Self-Performed Work	Contract Amount Completion Date % Self-Performed Work	Contract Amount Completion Date % Self-Performed Work	Contract Amount Completion Date % Self-Performed Work
PROJECT DELIVERY METHOD	<input type="checkbox"/> Design-bid-build <input type="checkbox"/> Design-build <input type="checkbox"/> CM constructor <input type="checkbox"/> CM advisor <input type="checkbox"/> Other:	<input type="checkbox"/> Design-bid-build <input type="checkbox"/> Design-build <input type="checkbox"/> CM constructor <input type="checkbox"/> CM advisor <input type="checkbox"/> Other:	<input type="checkbox"/> Design-bid-build <input type="checkbox"/> Design-build <input type="checkbox"/> CM constructor <input type="checkbox"/> CM advisor <input type="checkbox"/> Other:	<input type="checkbox"/> Design-bid-build <input type="checkbox"/> Design-build <input type="checkbox"/> CM constructor <input type="checkbox"/> CM advisor <input type="checkbox"/> Other:
SUSTAINABILITY CERTIFICATIONS				



AIA[®]

Document A305™ – 2020 Exhibit E

Contractor's Past Project Experience, Continued

	1	2	3	4
PROJECT NAME				
PROJECT LOCATION				
PROJECT TYPE				
OWNER				
ARCHITECT				
CONTRACTOR'S PROJECT EXECUTIVE				
KEY PERSONNEL (include titles)				
PROJECT DETAILS	Contract Amount Completion Date % Self-Performed Work	Contract Amount Completion Date % Self-Performed Work	Contract Amount Completion Date % Self-Performed Work	Contract Amount Completion Date % Self-Performed Work
PROJECT DELIVERY METHOD	<input type="checkbox"/> Design-bid-build <input type="checkbox"/> Design-build <input type="checkbox"/> CM constructor <input type="checkbox"/> CM advisor <input type="checkbox"/> Other:	<input type="checkbox"/> Design-bid-build <input type="checkbox"/> Design-build <input type="checkbox"/> CM constructor <input type="checkbox"/> CM advisor <input type="checkbox"/> Other:	<input type="checkbox"/> Design-bid-build <input type="checkbox"/> Design-build <input type="checkbox"/> CM constructor <input type="checkbox"/> CM advisor <input type="checkbox"/> Other:	<input type="checkbox"/> Design-bid-build <input type="checkbox"/> Design-build <input type="checkbox"/> CM constructor <input type="checkbox"/> CM advisor <input type="checkbox"/> Other:
SUSTAINABILITY CERTIFICATIONS				

DRAFT AIA® Document A132™ - 2019

Standard Form of Agreement Between Owner and Contractor, Construction Manager as Adviser Edition

AGREEMENT made as of the « » day of « » in the year « »
(In words, indicate day, month, and year.)

BETWEEN the Owner:
(Name, legal status, address, and other information)

«Yonkers Joint Schools Construction Board»«»
«City Hall
40 South Broadway
Yonkers, NY 10701»
«»
«»

and the Contractor:
(Name, legal status, address, and other information)

« »« »
« »
« »
« »

for the following Project:
(Name, location, and detailed description)

«Community School 35»
«121 McLean Avenue,
Yonkers, NY 10705»
« »

The Construction Manager:
(Name, legal status, address, and other information)

«Savin Engineers, PC»«»
«3 Campus Drive
Pleasantville, NY 10570»
«»
«»

The Architect:
(Name, legal status, address, and other information)

«KG+D Architects, PC»«»
«285 Main Street
Mount Kisco, NY 10549»
«»
«»

The Owner and Contractor agree as follows.

ADDITIONS AND DELETIONS:
The author of this document has added information needed for its completion. The author may also have revised the text of the original AIA standard form. An *Additions and Deletions Report* that notes added information as well as revisions to the standard form text is available from the author and should be reviewed.

This document has important legal consequences. Consultation with an attorney is encouraged with respect to its completion or modification.

This document is intended to be used in conjunction with AIA Documents A232™-2019, General Conditions of the Contract for Construction, Construction Manager as Adviser Edition; B132™-2019, Standard Form of Agreement Between Owner and Architect, Construction Manager as Adviser Edition; and C132™-2019, Standard Form of Agreement Between Owner and Construction Manager as Adviser. AIA Document A232™-2019 is adopted in this document by reference. Do not use with other general conditions unless this document is modified.

ELECTRONIC COPYING of any portion of this AIA® Document to another electronic file is prohibited and constitutes a violation of copyright laws as set forth in the footer of this document.

TABLE OF ARTICLES

- 1 THE CONTRACT DOCUMENTS
- 2 THE WORK OF THIS CONTRACT
- 3 DATE OF COMMENCEMENT AND DATES OF SUBSTANTIAL COMPLETION
- 4 CONTRACT SUM
- 5 PAYMENTS
- 6 DISPUTE RESOLUTION
- 7 TERMINATION OR SUSPENSION
- 8 MISCELLANEOUS PROVISIONS
- 9 ENUMERATION OF CONTRACT DOCUMENTS

EXHIBIT A INSURANCE AND BONDS

EXHIBIT B DETERMINATION OF THE COST OF THE WORK

ARTICLE 1 THE CONTRACT DOCUMENTS

The Contract Documents consist of this Agreement, Conditions of the Contract (General, Supplementary, and other Conditions), Drawings, Specifications, Addenda issued prior to execution of this Agreement, other documents listed in this Agreement, and Modifications issued after execution of this Agreement, all of which form the Contract, and are as fully a part of the Contract as if attached to this Agreement or repeated herein. The Contract represents the entire and integrated agreement between the parties hereto and supersedes prior negotiations, representations, or agreements, either written or oral. An enumeration of the Contract Documents, other than Modifications, appears in Article 9.

ARTICLE 2 THE WORK OF THIS CONTRACT

The Contractor shall fully execute the Work described in the Contract Documents, except as specifically indicated in the Contract Documents to be the responsibility of others.

ARTICLE 3 DATE OF COMMENCEMENT AND DATES OF SUBSTANTIAL COMPLETION

§ 3.1 The date of commencement of the Work shall be:
(Check one of the following boxes.)

The date of this Agreement.

A date set forth in a notice to proceed issued by the Owner.

Established as follows:
(Insert a date or a means to determine the date of commencement of the Work.)

If a date of commencement of the Work is not selected, then the date of commencement shall be the date of this Agreement.

§ 3.2 The Contract Time shall be measured from the date of commencement of the Work.

§ 3.3 Substantial Completion of the Project or Portions Thereof

§ 3.3.1 Subject to adjustments of the Contract Time as provided in the Contract Documents, the date of Substantial Completion of the Work of all of the Contractors for the Project will be:
(Insert the date of Substantial Completion of the Work of all Contractors for the Project.)

§ 3.3.2 Subject to adjustments of the Contract Time as provided in the Contract Documents, if portions of the Work of all of the Contractors for the Project are to be completed prior to Substantial Completion of the entire Work of all of the Contractors for the Project, the Contractors shall achieve Substantial Completion of such portions by the following dates:

Portion of Work	Substantial Completion Date

§ 3.4 When the Work of this Contract, or any Portion Thereof, is Substantially Complete

§ 3.4.1 Subject to adjustments of the Contract Time as provided in the Contract Documents, the Contractor shall substantially complete the entire Work of this Contract:

(Check one of the following boxes and complete the necessary information.)

[] Not later than () calendar days from the date of commencement of the Work.

[] By the following date: August 15, 2023

§ 3.4.2 Subject to adjustments of the Contract Time as provided in the Contract Documents, if portions of the Work of this Contract are to be substantially complete prior to when the entire Work of this Contract shall be substantially complete, the Contractor shall substantially complete such portions by the following dates:

Portion of Work	Date to be substantially complete

§ 3.4.3 If the Contractor fails to substantially complete the Work of this Contract, or portions thereof, as provided in this Section 3.4, liquidated damages, if any, shall be assessed as set forth in Section 4.5.

ARTICLE 4 CONTRACT SUM

§ 4.1 The Owner shall pay the Contractor the Contract Sum in current funds for the Contractor’s performance of the Contract. The Contract Sum shall be one of the following:

(Check the appropriate box.)

[] Stipulated Sum, in accordance with Section 4.2 below

[] Cost of the Work plus the Contractor’s Fee, in accordance with Section 4.3 below

[] Cost of the Work plus the Contractor’s Fee with a Guaranteed Maximum Price, in accordance with Section 4.4 below

(Based on the selection above, complete Section 4.2, 4.3 or 4.4 below.)

§ 4.2 Stipulated Sum

§ 4.2.1 The Contract Sum shall be (\$), subject to additions and deductions as provided in the Contract Documents.

§ 4.2.2 Alternates

§ 4.2.2.1 Alternates, if any, included in the Contract Sum:

Item	Price

§ 4.2.2.2 Subject to the conditions noted below, the following alternates may be accepted by the Owner following execution of this Agreement. Upon acceptance, the Owner shall issue a Modification to this Agreement.

(Insert below each alternate and the conditions that must be met for the Owner to accept the alternate.)

Item	Price	Conditions for Acceptance

§ 4.2.3 Allowances, if any, included in the Contract Sum:
(Identify each allowance.)

Item	Price

§ 4.2.4 Unit prices, if any:
(Identify the item and state the unit price, and quantity limitations, if any, to which the unit price will be applicable.)

Item	Units and Limitations	Price per Unit (\$0.00)



~~§ 4.3 Cost of the Work Plus Contractor's Fee without a Guaranteed Maximum Price~~

~~§ 4.3.1 The Cost of the Work is as defined in Exhibit B, Determination of the Cost of the Work.~~

~~§ 4.3.2 The Contractor's Fee:~~

~~(State a lump sum, percentage of Cost of the Work or other provision for determining the Contractor's Fee.)~~

~~«→»~~

~~§ 4.3.3 The method of adjustment of the Contractor's Fee for changes in the Work:~~

~~«→»~~

~~§ 4.3.4 Limitations, if any, on a Subcontractor's overhead and profit for increases in the cost of its portion of the Work:~~

~~«→»~~

~~§ 4.3.5 Rental rates for Contractor-owned equipment shall not exceed «→» percent («→» %) of the standard rental rate paid at the place of the Project.~~

~~§ 4.3.6 Unit prices, if any:~~

~~(Identify the item and state the unit price and quantity limitations, if any, to which the unit price will be applicable.)~~

Item	Units and Limitations	Price per Unit (\$0.00)
-----------------	----------------------------------	------------------------------------

~~§ 4.3.7 The Contractor shall prepare and submit to the Construction Manager, within 14 days of executing this Agreement, a written Control Estimate for the Owner's review and approval. The Control Estimate shall include the items in Section B.1 of Exhibit B, Determination of the Cost of the Work.~~

~~§ 4.4 Cost of the Work Plus Contractor's Fee with a Guaranteed Maximum Price~~

~~§ 4.4.1 The Cost of the Work is as defined in Exhibit B, Determination of the Cost of the Work.~~

~~§ 4.4.2 The Contractor's Fee:~~

~~(State a lump sum, percentage of Cost of the Work or other provision for determining the Contractor's Fee.)~~

~~«→»~~

~~§ 4.4.3 The method of adjustment of the Contractor's Fee for changes in the Work:~~

~~«→»~~

~~§ 4.4.4 Limitations, if any, on a Subcontractor's overhead and profit for increases in the cost of its portion of the Work:~~

~~«→»~~

~~§ 4.4.5 Rental rates for Contractor-owned equipment shall not exceed «→» percent («→» %) of the standard rental rate paid at the place of the Project.~~

~~§ 4.4.6 Unit Prices, if any:~~

~~(Identify the item and state the unit price and quantity limitations, if any, to which the unit price will be applicable.)~~

Item	Units and Limitations	Price per Unit (\$0.00)
-----------------	----------------------------------	------------------------------------

~~§ 4.4.7 Guaranteed Maximum Price~~

~~§ 4.4.7.1 The Contract Sum is guaranteed by the Contractor not to exceed \llcorner (\$ \llcorner), subject to additions and deductions by Change Order as provided in the Contract Documents. This maximum sum is referred to in the Contract Documents as the Guaranteed Maximum Price. Costs which would cause the Guaranteed Maximum Price to be exceeded shall be paid by the Contractor without reimbursement by the Owner.~~

~~§ 4.4.7.2 Alternates~~

~~§ 4.4.7.2.1 Alternates, if any, included in the Guaranteed Maximum Price:~~

Item	Price
------	-------

~~§ 4.4.7.2.2 Subject to the conditions noted below, the following alternates may be accepted by the Owner following execution of this Agreement. Upon acceptance, the Owner shall issue a Modification to this Agreement. (Insert below each alternate and the conditions that must be met for the Owner to accept the alternate.)~~

Item	Price	Conditions for Acceptance
------	-------	---------------------------

~~§ 4.4.7.3 Allowances, if any, included in the Guaranteed Maximum Price: (Identify each allowance.)~~

Item	Price
------	-------

~~§ 4.4.7.4 Assumptions, if any, upon which the Guaranteed Maximum Price is based: (Identify each assumption.)~~

~~\llcorner~~

~~§ 4.4.8 To the extent that the Contract Documents are anticipated to require further development, the Guaranteed Maximum Price includes the costs attributable to such further development consistent with the Contract Documents and reasonably inferable therefrom. Such further development does not include changes in scope, systems, kinds and quality of materials, finishes, or equipment, all of which, if required, shall be incorporated by Change Order.~~

~~§ 4.4.9 The Owner shall authorize preparation of revisions to the Contract Documents that incorporate the agreed-upon assumptions contained in Section 4.4.7.4. The Owner shall promptly furnish such revised Contract Documents to the Contractor. The Contractor shall notify the Owner and Architect of any inconsistencies between the agreed-upon assumptions contained in Section 4.4.7.4 and the revised Contract Documents.~~

§ 4.5 Liquidated damages, if any:

(Insert terms and conditions for liquidated damages, if any, to be assessed in accordance with Section 3.4.)

~~\llcorner If the Contractor fails to achieve Substantial Completion within the Contract Time, the Contractor shall be liable for the sum of Five Hundred dollars (\$500.00) as liquidated damages, and not as a penalty-, for each calendar day beginning on the first day after the Contractor fails to achieve Substantial Completion within the Contract Time until the date that Substantial Completion is achieved \llcorner~~

§ 4.6 Other:

(Insert provisions for bonus, cost savings or other incentives, if any, that might result in a change to the Contract Sum.)

~~\llcorner~~

ARTICLE 5 PAYMENTS

§ 5.1 Progress Payments

§ 5.1.1 Based upon Applications for Payment submitted to the Construction Manager by the Contractor, and Certificates for Payment issued by the Construction Manager and Architect, the Owner shall make progress payments on account of the Contract Sum, to the Contractor, as provided below and elsewhere in the Contract Documents.

§ 5.1.2 The period covered by each Application for Payment shall be one calendar month ending on the last day of the month, or as follows:

<< >>

§ 5.1.3 ~~Provided that an Application for Payment is received by the Construction Manager not later than the <> day of a month, the Owner shall make payment of the amount certified to the Contractor not later than the <> day of the <> month. If an Application for Payment is received by the Construction Manager after the application date fixed above, payment of the amount certified shall be made by the Owner not later than <> (<>) days after the Construction Manager receives the Application for Payment. When making Progress Payments the Contractor shall provide as part of the application for payment the following:~~

- a. Certified Payroll
- c. Partial Waiver of Liens for that portion of the work, materials, Sub-contractors and or Suppliers.
- d. Updated Construction Schedule

The contractor shall submit a "pencil-copy" requisition to the Construction Manager no later than the 25th of the month estimated for work completed to the end of the month for review with field personnel.

After any adjustments are made, the Contractor shall finalize and submit to the Construction Manager four (4) original copies, partial waiver of liens, certified payroll, and 10 hour OSHA cards signed, notarized, for forwarding to the Architect for final approval and signature.

The Owner has 30 days to make payment of the amount certified to the Contractor upon receipt of the four (4) original copies signed by the Architect and Construction Manager, including partial waiver of liens, certified payroll, and 10 hour OSHA cards.

All of the above documents shall be paper clipped, not stapled. Incomplete applications for payment will not be considered.

(Federal, state or local laws may require payment within a certain period of time.)

§ 5.1.4 Progress Payments Where the Contract Sum is Based on a Stipulated Sum

§ 5.1.4.1 Each Application for Payment shall be based on the most recent schedule of values submitted by the Contractor in accordance with the Contract Documents. The schedule of values shall allocate the entire Contract Sum among the various portions of the Work. The schedule of values shall be prepared in such form, and supported by such data to substantiate its accuracy, as the Construction Manager and Architect may require. This schedule of values shall be used as a basis for reviewing the Contractor's Applications for Payment.

§ 5.1.4.2 Applications for Payment shall show the percentage of completion of each portion of the Work as of the end of the period covered by the Application for Payment.

§ 5.1.4.3 In accordance with AIA Document A232™–2019, General Conditions of the Contract for Construction, Construction Manager as Adviser Edition, and subject to other provisions of the Contract Documents, the amount of each progress payment shall be computed as follows:

§ 5.1.4.3.1 The amount of each progress payment shall first include:

- .1 That portion of the Contract Sum properly allocable to completed Work;
- .2 That portion of the Contract Sum properly allocable to materials and equipment delivered and suitably stored at the site for subsequent incorporation in the completed construction, or, if approved in advance by the Owner, suitably stored off the site at a location agreed upon in writing; and
- .3 That portion of Construction Change Directives that the Architect determines, in the Architect's professional judgment, to be reasonably justified.

§ 5.1.4.3.2 The amount of each progress payment shall then be reduced by:

- .1 The aggregate of any amounts previously paid by the Owner;
- .2 The amount, if any, for Work that remains uncorrected and for which the Architect has previously withheld a Certificate for Payment as provided in Article 9 of AIA Document A232–2019;

- .3 Any amount for which the Contractor does not intend to pay a Subcontractor or material supplier, unless the Work has been performed by others the Contractor intends to pay;
- .4 For Work performed or defects discovered since the last payment application, any amount for which the Architect may withhold payment, or nullify a Certificate of Payment in whole or in part, as provided in Article 9 of AIA Document A232–2019; and
- .5 Retainage withheld pursuant to Section 5.1.7.



~~§ 5.1.5 Progress Payments Where the Contract Sum is Based on the Cost of the Work without a Guaranteed Maximum Price~~

~~§ 5.1.5.1 With each Application for Payment, the Contractor shall submit the cost control information required in Exhibit B, Determination of the Cost of the Work, along with payrolls, petty cash accounts, receipted invoices, or invoices with check vouchers attached, and any other evidence required by the Owner, Construction Manager or Architect to demonstrate that payments already made by the Contractor on account of the Cost of the Work equal or exceed progress payments already received by the Contractor, plus payrolls for the period covered by the present Application for Payment, less that portion of the payments attributable to the Contractor's Fee.~~

~~§ 5.1.5.2 Applications for Payment shall show the Cost of the Work actually incurred by the Contractor through the end of the period covered by the Application for Payment and for which the Contractor has made or intends to make actual payment prior to the next Application for Payment.~~

~~§ 5.1.5.3 In accordance with AIA Document A232-2019 and subject to other provisions of the Contract Documents, the amount of each progress payment shall be computed as follows:~~

~~§ 5.1.5.3.1 The amount of each progress payment shall first include:~~

- ~~.1 The Cost of the Work as described in Exhibit B, Determination of the Cost of the Work;~~
- ~~.2 That portion of Construction Change Directives that the Architect determines, in the Architect's professional judgment, to be reasonably justified; and~~
- ~~.3 The Contractor's Fee computed upon the Cost of the Work described in the preceding Section 5.1.5.3.1.1 at the rate stated in Section 4.3.2; or if the Contractor's Fee is stated as a fixed sum in Section 4.3.2 an amount which bears the same ratio to that fixed sum Fee as the Cost of the Work included in Section 5.1.5.3.1.1 bears to a reasonable estimate of the probable Cost of the Work upon its completion.~~

~~§ 5.1.5.3.2 The amount of each progress payment shall then be reduced by:~~

- ~~.1 The aggregate of any amounts previously paid by the Owner;~~
- ~~.2 The amount, if any, for Work that remains uncorrected and for which the Architect has previously withheld a Certificate for Payment as provided in Article 9 of AIA Document A232-2019;~~
- ~~.3 Any amount for which the Contractor does not intend to pay a Subcontractor or material supplier, unless the Work has been performed by others the Contractor intends to pay;~~
- ~~.4 For Work performed or defects discovered since the last payment application, any amount for which the Architect may withhold payment, or nullify a Certificate of Payment in whole or in part, as provided in Article 9 of AIA Document A232-2019;~~
- ~~.5 The shortfall, if any, indicated by the Contractor in the documentation required by Section 5.1.5.1 to substantiate prior Applications for Payment, or resulting from errors subsequently discovered by the Owner's auditors in such documentation; and~~
- ~~.6 Retainage withheld pursuant to Section 5.1.7.~~

~~§ 5.1.5.4 The Owner, Construction Manager and Contractor shall agree upon a mutually acceptable procedure for review and approval of payments to Subcontractors and the percentage of retainage held on Subcontracts, and the Contractor shall execute subcontracts in accordance with those agreements.~~

~~§ 5.1.5.5 In taking action on the Contractor's Applications for Payment, the Construction Manager and Architect shall be entitled to rely on the accuracy and completeness of the information furnished by the Contractor, and such action shall not be deemed to be a representation that (1) the Construction Manager and Architect have made a detailed examination, audit or arithmetic verification of the documentation submitted in accordance with Article 5 or other supporting data; (2) that the Construction Manager and Architect have made exhaustive or continuous on-site inspections; or (3) that the Construction Manager and Architect have made examinations to ascertain how or for what purposes the Contractor has used amounts previously paid on account of the Contract. Such examinations, audits and verifications, if required by the Owner, will be performed by the Owner's auditors acting in the sole interest of the Owner.~~

~~§ 5.1.5.6 Except with the Owner's prior approval, the Contractor shall not make advance payments to suppliers for materials or equipment which have not been delivered and stored at the site.~~

~~§ 5.1.5.7 If final completion of the Work is materially delayed through no fault of the Contractor, then the Owner shall pay the Contractor any additional amounts in accordance with Article 9 of AIA Document A232-2019.~~

§ 5.1.6 Progress Payments Where the Contract Sum is Based on the Cost of the Work with a Guaranteed Maximum Price

§ 5.1.6.1 With each Application for Payment, the Contractor shall submit payrolls, petty cash accounts, receipted invoices or invoices with check vouchers attached, and any other evidence required by the Owner, Construction Manager or Architect to demonstrate that payments already made by the Contractor on account of the Cost of the Work equal or exceed progress payments already received by the Contractor plus payrolls for the period covered by the present Application for Payment, less that portion of the progress payments attributable to the Contractor's Fee.

§ 5.1.6.2 Each Application for Payment shall be based on the most recent schedule of values submitted by the Contractor in accordance with the Contract Documents. The schedule of values shall allocate the entire Guaranteed Maximum Price among: (1) the various portions of the Work; (2) any contingency for costs that are included in the Guaranteed Maximum Price but not otherwise allocated to another line item or included in a Change Order; and (3) the Contractor's Fee.

§ 5.1.6.2.1 The schedule of values shall be prepared in such form, and supported by such data to substantiate its accuracy, as the Construction Manager and Architect may require. This schedule of values shall be used as a basis for reviewing the Contractor's Applications for Payment.

§ 5.1.6.2.2 The allocation of the Guaranteed Maximum Price under this Section 5.1.6.2 shall not constitute a separate guaranteed maximum price for the Cost of the Work of each individual line item in the schedule of values.

§ 5.1.6.2.3 When the Contractor allocates costs from a contingency to another line item in the schedule of values, the Contractor shall submit supporting documentation to the Architect and Construction Manager.

§ 5.1.6.3 Applications for Payment shall show the percentage of completion of each portion of the Work as of the end of the period covered by the Application for Payment. The percentage of completion shall be the lesser of (1) the percentage of that portion of the Work which has actually been completed; or (2) the percentage obtained by dividing (a) the expense that has actually been incurred by the Contractor on account of that portion of the Work and for which the Contractor has made payment or intends to make payment prior to the next Application for Payment by (b) the share of the Guaranteed Maximum Price allocated to that portion of the Work in the schedule of values.

§ 5.1.6.4 In accordance with AIA Document A232-2019, and subject to other provisions of the Contract Documents, the amount of each progress payment shall be computed as follows:

§ 5.1.6.4.1 The amount of each progress payment shall first include:

- .1 That portion of the Guaranteed Maximum Price properly allocable to completed Work as determined by multiplying the percentage of completion of each portion of the Work by the share of the Guaranteed Maximum Price allocated to that portion of the Work in the most recent schedule of values;
- .2 That portion of the Guaranteed Maximum Price properly allocable to materials and equipment delivered and suitably stored at the site for subsequent incorporation in the completed construction or, if approved in writing in advance by the Owner, suitably stored off the site at a location agreed upon in writing;
- .3 That portion of Construction Change Directives that the Architect determines, in the Architect's professional judgment, to be reasonably justified; and
- .4 The Contractor's Fee, computed upon the Cost of the Work described in the preceding Sections 5.1.6.4.1.1 and 5.1.6.4.1.2 at the rate stated in Section 4.4.2 or, if the Contractor's Fee is stated as a fixed sum in that Section, an amount that bears the same ratio to that fixed sum fee as the Cost of the Work included in Sections 5.1.6.4.1.1 and 5.1.6.4.1.2 bears to a reasonable estimate of the probable Cost of the Work upon its completion.

§ 5.1.6.4.2 The amount of each progress payment shall then be reduced by:

- .1 The aggregate of any amounts previously paid by the Owner;
- .2 The amount, if any, for Work that remains uncorrected and for which the Architect has previously withheld a Certificate for Payment as provided in Article 9 of AIA Document A232-2019;
- .3 Any amount for which the Contractor does not intend to pay a Subcontractor or material supplier, unless the Work has been performed by others the Contractor intends to pay;
- .4 For Work performed or defects discovered since the last payment application, any amount for which the Architect may withhold payment, or nullify a Certificate of Payment in whole or in part, as provided in Article 9 of AIA Document A232-2019;

~~5 The shortfall, if any, indicated by the Contractor in the documentation required by Section 5.1.6.1 to substantiate prior Applications for Payment, or resulting from errors subsequently discovered by the Owner's auditors in such documentation; and~~

~~6 Retainage withheld pursuant to Section 5.1.7.~~

~~§ 5.1.6.5 The Owner and the Contractor shall agree upon a mutually acceptable procedure for review and approval of payments to Subcontractors and the percentage of retainage held on Subcontracts, and the Contractor shall execute subcontracts in accordance with those agreements.~~

~~§ 5.1.6.6 In taking action on the Contractor's Applications for Payment, the Construction Manager and Architect shall be entitled to rely on the accuracy and completeness of the information furnished by the Contractor and such action shall not be deemed to be a representation that (1) the Construction Manager or Architect have made a detailed examination, audit, or arithmetic verification of the documentation submitted in accordance with Section 5.1.6.1 or other supporting data; (2) that the Construction Manager or Architect have made exhaustive or continuous on-site inspections; or (3) that the Construction Manager or Architect have made examinations to ascertain how or for what purposes the Contractor has used amounts previously paid on account of the Contract. Such examinations, audits, and verifications, if required by the Owner, will be performed by the Owner's auditors acting in the sole interest of the Owner.~~

~~§ 5.1.6.7 Except with the Owner's prior approval, the Contractor shall not make advance payments to suppliers for materials or equipment which have not been delivered and stored at the site.~~

~~§ 5.1.6.8 If final completion of the Work is materially delayed through no fault of the Contractor, then the Owner shall pay the Contractor any additional amounts in accordance with Article 9 of AIA Document A232-2019.~~

§ 5.1.7 Retainage

§ 5.1.7.1 For each progress payment made prior to when the Work of this Contract is substantially complete, the Owner may withhold the following amount, as retainage, from the payment otherwise due:

(Insert a percentage or amount to be withheld as retainage from each Application for Payment. The amount of retainage may be limited by governing law.)

«Until Substantial Completion, the Owner will pay 95 percent of the amount due the Contractor on account of progress payments and shall hold the remaining five percent (5%) as retainage.»

§ 5.1.7.1.1 The following items are not subject to retainage:

(Insert any items not subject to the withholding of retainage, such as general conditions, insurance, etc.)

« »

§ 5.1.7.2 Reduction or limitation of retainage, if any, shall be as follows:

(If the retainage established in Section 5.1.7.1 is to be modified prior to when the entire Work of this Contract is substantially complete, including modifications for completion of portions of the Work as provided in Section 3.4.2, insert provisions for such modifications.)

« »

§ 5.1.7.3 Except as set forth in this Section 5.1.7.3, when the Work of this Contract is substantially complete, the Contractor may submit an Application for Payment that includes the retainage withheld from prior Applications for Payment pursuant to this Section 5.1.7. The Application for Payment submitted when the Work of this Contract is substantially complete shall not include retainage as follows:

(Insert any other conditions for release of retainage when the Work of this Contract is substantially complete, or upon Substantial Completion of the Work of all Contractors on the Project or portions thereof.)

« When the work or major portions thereof as contemplated by the terms of the Contract are substantially completed, the Contractor shall submit to the Architect a requisition for payment of the remaining amount of the Contract balance. Upon receipt of such requisition the Owner shall approve and promptly pay the remaining amount of the Contract balance less two times the value of any remaining items to be completed and an amount necessary to satisfy any claims, liens or judgements against the Contractor which have not been suitably discharged. Any claims, liens and judgements

referred to in this clause shall pertain to the Project and shall be filed in accordance with the terms of the Contract, and applicable laws—>

§ 5.2 Final Payment

§ 5.2.1 Final Payment Where the Contract Sum is Based on a Stipulated Sum

§ 5.2.1.1 Final payment, constituting the entire unpaid balance of the Contract Sum, shall be made by the Owner to the Contractor when

- .1 the Contractor has fully performed the Contract except for the Contractor's responsibility to correct Work as provided in Article 12 of AIA Document A232–2019, and to satisfy other requirements, if any, which extend beyond final payment; and
- .2 a final Certificate for Payment or Project Certificate for Payment has been issued by the Architect.

§ 5.2.1.2 The Owner's final payment to the Contractor shall be made no later than 30 days after the issuance of the final Certificate for Payment or Project Certificate for Payment, or as follows:

<< >>

~~§ 5.2.2 Final Payment Where the Contract Sum is Based on the Cost of the Work with or without a Guaranteed Maximum Price~~

~~§ 5.2.2.1 Final payment, constituting the entire unpaid balance of the Contract Sum, shall be made by the Owner to the Contractor when~~

- ~~.1 the Contractor has fully performed the Contract except for the Contractor's responsibility to correct Work as provided in Article 12 of AIA Document A232–2019, and to satisfy other requirements, if any, which extend beyond final payment;~~
- ~~.2 the Contractor has submitted a final accounting for the Cost of the Work, pursuant to Exhibit B, Determination of the Cost of the Work and a final Application for Payment; and~~
- ~~.3 a final Certificate for Payment or Project Certificate for Payment has been issued by the Architect in accordance with Exhibit B, Determination of the Cost of the Work.~~

~~§ 5.2.2.2 The Owner's final payment to the Contractor shall be made no later than 30 days after the issuance of the final Certificate for Payment or Project Certificate for Payment, or as follows:~~

←→

§ 5.3 Payments due and unpaid under the Contract shall bear interest from the date payment is due at the rate stated below, or in the absence thereof, at the legal rate prevailing from time to time at the place where the Project is located. *(Insert rate of interest agreed upon, if any.)*

<< >> % << >>

ARTICLE 6 DISPUTE RESOLUTION

§ 6.1 Initial Decision Maker

The Architect will serve as Initial Decision Maker pursuant to Article 15 of AIA Document A232–2019, unless the parties appoint below another individual, not a party to this Agreement, to serve as Initial Decision Maker.

(If the parties mutually agree, insert the name, address and other contact information of the Initial Decision Maker, if other than the Architect.)

<< >>

<< >>

<< >>

<< >>

§ 6.2 Binding Dispute Resolution

For any Claim subject to, but not resolved by, mediation pursuant to Article 15 of AIA Document A232–2019, the method of binding dispute resolution shall be as follows:

(Check the appropriate box.)

[] Arbitration pursuant to Article 15 of AIA Document A232–2019.

[] Litigation in a court of competent jurisdiction.

[] Other: *(Specify)*

If the Owner and Contractor do not select a method of binding dispute resolution, or do not subsequently agree in writing to a binding dispute resolution method other than litigation, Claims will be resolved by litigation in a court of competent jurisdiction.

ARTICLE 7 TERMINATION OR SUSPENSION

§ 7.1 Where the Contract Sum is a Stipulated Sum

§ 7.1.1 The Contract may be terminated by the Owner or the Contractor as provided in Article 14 of AIA Document A232–2019.

§ 7.1.1.1 If the Contract is terminated for the Owner’s convenience in accordance with Article 14 of AIA Document A232–2019, then the Owner shall pay the Contractor a termination fee as follows:

(Insert the amount of, or method for determining, the fee, if any, payable to the Contractor following a termination for the Owner’s convenience.)

«NONE »

§ 7.1.2 The Work may be suspended by the Owner as provided in Article 14 of AIA Document A232–2019.

~~§ 7.2 Where the Contract Sum is Based on the Cost of the Work with or without a Guaranteed Maximum Price~~

~~§ 7.2.1 Termination~~

~~§ 7.2.1.1 The Contract may be terminated by the Owner or the Contractor as provided in Article 14 of AIA Document A232-2019.~~

~~§ 7.2.1.2 Termination by the Owner for Cause~~

~~§ 7.2.1.2.1 If the Owner terminates the Contract for cause as provided in Article 14 of AIA Document A232-2019, the Owner shall then only pay the Contractor an amount as follows:~~

- ~~.1 Take the Cost of the Work incurred by the Contractor to the date of termination;~~
- ~~.2 Add the Contractor's Fee, computed upon the Cost of the Work to the date of termination at the rate stated in Section 4.3.2 or 4.4.2, as applicable, or, if the Contractor's Fee is stated as a fixed sum in that Section, an amount that bears the same ratio to that fixed-sum Fee as the Cost of the Work at the time of termination bears to a reasonable estimate of the probable Cost of the Work upon its completion;~~
- ~~.3 Subtract the aggregate of previous payments made by the Owner; and~~
- ~~.4 Subtract the costs and damages incurred, or to be incurred, by the Owner under Article 14 of AIA Document A232-2019.~~

~~§ 7.2.1.2.2 When the Contract Sum is based on the Cost of the Work with a Guaranteed Maximum Price, if the Owner terminates the Contract for cause as provided in Article 14 of AIA Document A232-2019, the amount, if any, to be paid to the Contractor under Article 14 of AIA Document A232-2019 shall not cause the Guaranteed Maximum Price to be exceeded, nor shall it exceed the amount calculated in Section 7.2.1.2.1.~~

~~§ 7.2.1.2.3 The Owner shall also pay the Contractor fair compensation, either by purchase or rental at the election of the Owner, for any equipment owned by the Contractor that the Owner elects to retain and that is not otherwise included in the Cost of the Work under Section 7.2.1.2.1.1. To the extent that the Owner elects to take legal assignment of subcontracts and purchase orders (including rental agreements), the Contractor shall, as a condition of receiving the payments referred to in this Article 7, execute and deliver all such papers and take all such steps, including the legal assignment of such subcontracts and other contractual rights of the Contractor, as the Owner may require for the purpose of fully vesting in the Owner the rights and benefits of the Contractor under such subcontracts or purchase orders. All Subcontracts, purchase orders and rental agreements entered into by the Contractor will contain provisions allowing for assignment to the Owner as described above.~~

~~§ 7.2.1.3 Termination by the Owner for Convenience~~

~~If the Owner terminates the Contract for convenience in accordance with Article 14 of AIA Document A232-2019, then the Owner shall pay the Contractor a termination fee as follows:~~

~~(Insert the amount of or method for determining the fee, if any, payable to the Contractor following a termination for the Owner's convenience.)~~

~~←→~~

§ 7.3 Suspension

The Work may be suspended by the Owner as provided in Article 14 of AIA Document A232-2019; in such case, the Contract Sum and Contract Time shall be increased as provided in Article 14 of AIA Document A232-2019, except that the term "profit" shall be understood to mean the Contractor's Fee as described in Section 4.3.2 or 4.4.2, as applicable, of this Agreement.

ARTICLE 8 MISCELLANEOUS PROVISIONS

§ 8.1 Where reference is made in this Agreement to a provision of AIA Document A232-2019 or another Contract Document, the reference refers to that provision as amended or supplemented by other provisions of the Contract Documents.

§ 8.2 The Owner's representative:

(Name, address, email address, and other information)

«Mayor Mike Spano Marlyn Anderson, Secretary»

«Yonkers Joint Schools Construction Board»

«City Hall,

40 South Broadway

Yonkers, NY 10701»

« marlyn.anderson@yonkersny.gov »

<<>>

<<>>

<<>>

§ 8.3 The Contractor's representative:
(Name, address, email address, and other information)

<< >>

<< >>

<< >>

<< >>

<< >>

<< >>

§ 8.4 Neither the Owner's nor the Contractor's representative shall be changed without ten days' prior notice to the other party.

§ 8.5 Insurance and Bonds

§ 8.5.1 The Owner and the Contractor shall purchase and maintain insurance as set forth in AIA Document A132™–2019, Standard Form of Agreement Between Owner and Contractor, Construction Manager as Adviser Edition, Exhibit A, Insurance and Bonds, and elsewhere in the Contract Documents.

§ 8.5.2 The Contractor shall provide bonds as set forth in ~~AIA Document A132™–2019, Exhibit A, and elsewhere in the Contract Documents.~~

§ 8.6 Notice in electronic format, pursuant to Article 1 of AIA Document A232–2019, may be given in accordance with ~~AIA Document E203™–2013, Building Information Modeling and Digital Data Exhibit~~, if completed, or as otherwise as set forth below:

(If other than in accordance with AIA Document E203–2013, insert requirements for delivering notice in electronic format such as name, title, and email address of the recipient and whether and how the system will be required to generate a read receipt for the transmission.)

~~«Notice shall be given to the Owner's Representative and the Contractor's Representative at the e-mail addresses noted in this Agreement, with the electronic system generating a read receipt for the transmission. ->>~~

§ 8.7 Relationship of the Parties

~~Where the Contract is based on the Cost of the Work plus the Contractor's Fee, with or without a Guaranteed Maximum Price, the Contractor accepts the relationship of trust and confidence established by this Agreement and covenants with the Owner to cooperate with the Architect and exercise the Contractor's skill and judgment in furthering the interests of the Owner; to furnish efficient business administration and supervision; to furnish at all times an adequate supply of workers and materials; and to perform the Work in an expeditious and economical manner consistent with the Owner's interests. The Owner agrees to furnish and approve, in a timely manner, information required by the Contractor and to make payments to the Contractor in accordance with the requirements of the Contract Documents.~~

§ 8.8 Other provisions:

<< >>

ARTICLE 9 ENUMERATION OF CONTRACT DOCUMENTS

§ 9.1 This Agreement is comprised of the following documents:

- .1 AIA Document A132™–2019, Standard Form of Agreement Between Owner and Contractor, Construction Manager as Adviser Edition
- .2 ~~AIA Document A132™–2019, Exhibit A, Insurance and Bonds~~ Exhibit Owner's Insurance Requirements
- .3 AIA Document A232™–2019, General Conditions of the Contract for Construction, Construction Manager as Adviser Edition
- .4 ~~AIA Document E203™–2013, Building Information Modeling and Digital Data Exhibit~~, dated as indicated below:

(Insert the date of the E203-2013 incorporated into this Agreement.)

<< >>

.5 Drawings

Number	Title	Date

.6 Specifications

Section	Title	Date	Pages

.7 Addenda, if any:

Number	Date	Pages

Portions of Addenda relating to bidding or proposal requirements are not part of the Contract Documents unless the bidding or proposal requirements are also enumerated in this Article 9.

.8 Other Exhibits:

(Check all boxes that apply and include appropriate information identifying the exhibit where required.)

[] AIA Document A132™–2019, Exhibit B, Determination of the Cost of the Work

[] AIA Document E235™–2019, Sustainable Projects Exhibit, Construction Manager as Adviser Edition, dated as indicated below:

(Insert the date of the E235-2019 incorporated into this Agreement.)

<< >>

[] The Sustainability Plan:

Title	Date	Pages

[] Supplementary and other Conditions of the Contract:

Document	Title	Date	Pages

.9 Other documents, if any, listed below:

(List here any additional documents that are intended to form part of the Contract Documents. AIA Document A232–2019 provides that the advertisement or invitation to bid, Instructions to Bidders, sample forms, the Contractor’s bid or proposal, portions of Addenda relating to bidding or proposal requirements, and other information furnished by the Owner in anticipation of receiving bids or proposals, are not part of the Contract Documents unless enumerated in this Agreement. Any such documents should be listed here only if intended to be part of the Contract Documents.)

<< >>

This Agreement is entered into as of the day and year first written above.

OWNER (Signature)

« Mayor Mike Spano » « Chairman Marlyn Anderson, Secretary »

(Printed name and title)

CONTRACTOR (Signature)

« » « »

(Printed name and title)

TELEBARO

DRAFT AIA® Document A232™ - 2019

General Conditions of the Contract for Construction, Construction Manager as Adviser Edition

for the following PROJECT:

(Name, and location or address)

«Community School 35»
«121 McLean Avenue,
Yonkers, NY 10705»

THE CONSTRUCTION MANAGER:

(Name, legal status, and address)

«Savin Engineers, PC»«»
«3 Campus Drive
Pleasantville, NY 10570»

THE OWNER:

(Name, legal status, and address)

«Yonkers Joint Schools Construction Board»«»
«City Hall
40 South Broadway
Yonkers, NY 10701»

THE ARCHITECT:

(Name, legal status, and address)

«KG+D Architects, PC»«»
«285 Main Street
Mount Kisco, NY 10549»

ADDITIONS AND DELETIONS: The author of this document has added information needed for its completion. The author may also have revised the text of the original AIA standard form. An *Additions and Deletions Report* that notes added information as well as revisions to the standard form text is available from the author and should be reviewed.

This document has important legal consequences. Consultation with an attorney is encouraged with respect to its completion or modification.

This document is intended to be used in conjunction with AIA Documents A132™-2019, Standard Form of Agreement Between Owner and Contractor, Construction Manager as Adviser Edition; B132™-2019, Standard Form of Agreement Between Owner and Architect, Construction Manager as Adviser Edition; and C132™-2019, Standard Form of Agreement Between Owner and Construction Manager as Adviser.

ELECTRONIC COPYING of any portion of this AIA® Document to another electronic file is prohibited and constitutes a violation of copyright laws as set forth in the footer of this document.

TABLE OF ARTICLES

- 1 GENERAL PROVISIONS**
- 2 OWNER**
- 3 CONTRACTOR**
- 4 ARCHITECT AND CONSTRUCTION MANAGER**
- 5 SUBCONTRACTORS**
- 6 CONSTRUCTION BY OWNER OR BY SEPARATE CONTRACTORS**
- 7 CHANGES IN THE WORK**
- 8 TIME**
- 9 PAYMENTS AND COMPLETION**
- 10 PROTECTION OF PERSONS AND PROPERTY**
- 11 INSURANCE AND BONDS**
- 12 UNCOVERING AND CORRECTION OF WORK**
- 13 MISCELLANEOUS PROVISIONS**
- 14 TERMINATION OR SUSPENSION OF THE CONTRACT**
- 15 CLAIMS AND DISPUTES**



ARTICLE 1 GENERAL PROVISIONS

§ 1.1 Basic Definitions

§ 1.1.1 The Contract Documents. The Contract Documents are enumerated in the Agreement between the Owner and Contractor (hereinafter the Agreement) and consist of the Agreement, Conditions of the Contract (General, Supplementary and other Conditions), Drawings, Specifications, Addenda issued prior to execution of the Contract, other documents listed in the Agreement, and Modifications issued after execution of the Contract. A Modification is (1) a written amendment to the Contract signed by both parties, (2) a Change Order, (3) a Construction Change Directive, or (4) a written order for a minor change in the Work issued by the Architect. Unless specifically enumerated in the Agreement, the Contract Documents do not include the advertisement or invitation to bid, Instructions to Bidders, sample forms, other information furnished by the Owner in anticipation of receiving bids or proposals, the Contractor's bid or proposal, or portions of addenda relating to bidding or proposal requirements.

§ 1.1.2 The Contract. The Contract Documents form the Contract for Construction. The Contract represents the entire and integrated agreement between the parties hereto and supersedes prior negotiations, representations, or agreements, either written or oral. The Contract may be amended or modified only by a Modification. The Contract Documents shall not be construed to create a contractual relationship of any kind (1) between the Contractor and the Architect or the Architect's consultants, (2) between the Owner and the Construction Manager or the Construction Manager's consultants, (3) between the Owner and the Architect or the Architect's consultants, (4) between the Contractor and the Construction Manager or the Construction Manager's consultants, (5) between the Owner and a Subcontractor or Sub-subcontractor (6) between the Construction Manager and the Architect, or (7) between any persons or entities other than the Owner and Contractor. The Construction Manager and Architect shall, however, be entitled to performance and enforcement of obligations under the Contract intended to facilitate performance of their duties.

§ 1.1.3 The Work. The term "Work" means the construction and services required by the Contract Documents, whether completed or partially completed, and includes all other labor, materials, equipment, and services provided or to be provided by the Contractor to fulfill the Contractor's obligations. The Work may constitute the whole or a part of the Project.

§ 1.1.4 The Project. The Project is the total construction of which the Work performed under the Contract Documents may be the whole or a part and which may include construction by other Contractors, and by the Owner's own forces and Separate Contractors.

§ 1.1.5 Contractors. Contractors are persons or entities, other than the Contractor or Separate Contractors, who perform Work under contracts with the Owner that are administered by the Architect and Construction Manager.

§ 1.1.6 Separate Contractors. Separate Contractors are persons or entities who perform construction under separate contracts with the Owner not administered by the Architect and Construction Manager.

§ 1.1.7 The Drawings. The Drawings are the graphic and pictorial portions of the Contract Documents showing the design, location and dimensions of the Work, generally including plans, elevations, sections, details, schedules, and diagrams.

§ 1.1.8 The Specifications. The Specifications are that portion of the Contract Documents consisting of the written requirements for materials, equipment, systems, standards and workmanship for the Work, and performance of related services.

§ 1.1.9 Instruments of Service. Instruments of Service are representations, in any medium of expression now known or later developed, of the tangible and intangible creative work performed by the Architect and the Architect's consultants under their respective professional services agreements. Instruments of Service may include, without limitation, studies, surveys, models, sketches, drawings, specifications, and other similar materials.

§ 1.1.10 Initial Decision Maker. The Initial Decision Maker is the person identified in the Agreement to render initial decisions on Claims in accordance with Section 15.2. The Initial Decision Maker shall not show partiality to the Owner or Contractor and shall not be liable for results of interpretations or decisions rendered in good faith.

§ 1.2 Correlation and Intent of the Contract Documents

§ 1.2.1 The intent of the Contract Documents is to include all items necessary for the proper execution and completion of the Work by the Contractor. The Contract Documents are complementary, and what is required by one shall be as

binding as if required by all; performance by the Contractor shall be required only to the extent consistent with the Contract Documents and reasonably inferable from them as being necessary to produce the indicated results.

§ 1.2.1.1 The invalidity of any provision of the Contract Documents shall not invalidate the Contract or its remaining provisions. If it is determined that any provision of the Contract Documents violates any law, or is otherwise invalid or unenforceable, then that provision shall be revised to the extent necessary to make that provision legal and enforceable. In such case the Contract Documents shall be construed, to the fullest extent permitted by law, to give effect to the parties' intentions and purposes in executing the Contract.

§ 1.2.1.2 If, in the interpretation of Contract Documents, requirements within the Drawings and Specifications conflict, or it appears that the Drawings and Specifications are not in agreement, the requirement to be followed shall be decided by the Architect. Where there is a discrepancy in quantity, the Contractor shall provide the greater quantity; where there is a discrepancy in quality, the Contractor shall provide the superior quality. Addenda supersede the provisions that they amend.

§ 1.2.1.3 All dimensions and existing conditions shown on the Drawings are for bidding purposes only. It is the responsibility of the Contractor to verify all dimensions and existing conditions in the field to insure proper and accurate fit of materials and items to be installed.

§ 1.2.2 Organization of the Specifications into divisions, sections and articles, and arrangement of Drawings shall not control the Contractor in dividing the Work among Subcontractors or in establishing the extent of Work to be performed by any trade.

§ 1.2.3 Unless otherwise stated in the Contract Documents, words that have well-known technical or construction industry meanings are used in the Contract Documents in accordance with such recognized meanings.

§ 1.2.4 Sections of Division 01 - General Requirements govern the execution of all Sections of the Specifications.

§ 1.2.5 Miscellaneous Definitions. As used in the Contract Documents the term(s):

§ 1.2.5.1 'accepted,' 'directed,' 'permitted,' 'requested,' 'required,' and 'selected' mean, unless otherwise explained, 'accepted by the Architect,' 'directed by the Architect,' 'permitted by the Architect,' 'requested by the Architect,' 'required by the Architect,' and 'selected by the Architect.' However, no such implied meaning will be interpreted to extend the Architect's responsibility into the Contractor's area of construction supervision.

§ 1.2.5.2 'as accepted,' 'or acceptable substitute,' and 'for review' mean the Architect is the sole judge of the quality and suitability of the proposed substitutions. Where used in conjunction with the Architect's response to submittals, requests, applications, inquiries, reports, and claims by the Contractor, the meaning will be held to the limitations of the Architect's responsibilities and duties as stated in the General and Supplementary Conditions. In no case will 'accepted' by the Architect be interpreted as an assurance to the Contractor that the requirements of the Contract Documents have been fulfilled.

§ 1.2.5.3 'furnish' means supply and deliver to the Project site or other designated location, ready for unloading, unpacking, storing, assembly, installation, application, erection, or other form of incorporation into the Project, and maintained ready for use. Supply and deliver products requiring additional or supplemental fitting, assembly, fabrication, or incorporation into other elements of the Project directly to the fabricator, installer or manufacturer as required.

§ 1.2.5.4 'install' means unload, unpack, use, fit, attach, assemble, apply, place, anchor, erect, finish, cure, protect, clean, and similar operations required to properly incorporate work into the Project.

§ 1.2.5.5 'provide' means furnish and install.

§ 1.2.5.6 'replace' means remove designated, damaged, rejected, defective, unacceptable, or non-conforming work from the Project and provide new work meeting the requirements of the Contract Documents in place thereof.

§ 1.2.5.7 The word 'include,' in any form other than 'inclusive,' is non-limiting and is not intended to mean 'all-inclusive.'

§ 1.3 Capitalization

Terms capitalized in these General Conditions include those that are (1) specifically defined, (2) the titles of numbered articles, or (3) the titles of other documents published by the American Institute of Architects.

§ 1.4 Interpretation

In the interest of brevity the Contract Documents frequently omit modifying words such as “all” and “any” and articles such as “the” and “an,” but the fact that a modifier or an article is absent from one statement and appears in another is not intended to affect the interpretation of either statement.

§ 1.5 Ownership and Use of Drawings, Specifications, and Other Instruments of Service

§ 1.5.1 The Architect and the Architect’s consultants shall be deemed the authors and owners of their respective Instruments of Service, including the Drawings and Specifications, and retain all common law, statutory, and other reserved rights in their Instruments of Service, including copyrights. The Contractor, Subcontractors, sub-subcontractors, and suppliers shall not own or claim a copyright in the Instruments of Service. Submittal or distribution to meet official regulatory requirements or for other purposes in connection with the Project is not to be construed as publication in derogation of the Architect’s or Architect’s consultants’ reserved rights.

§ 1.5.2 The Contractor, Subcontractors, Sub-subcontractors, and suppliers are authorized to use and reproduce the Instruments of Service provided to them, subject to any protocols established pursuant to Sections 1.7 and 1.8, solely and exclusively for execution of the Work. All copies made under this authorization shall bear the copyright notice, if any, shown on the Instruments of Service. The Contractor, Subcontractors, Sub-subcontractors, and suppliers may not use the Instruments of Service on other projects or for additions to the Project outside the scope of the Work without the specific written consent of the Owner, Architect, and the Architect’s consultants.

§ 1.6 Notice

§ 1.6.1 Except as otherwise provided in Section 1.6.2, where the Contract Documents require one party to notify or give notice to the other party, such notice shall be provided in writing to the designated representative of the party to whom the notice is addressed and shall be deemed to have been duly served if delivered in person, by mail, by courier, or by electronic transmission if a method for electronic transmission is set forth in the Agreement.

§ 1.6.2 Notice of Claims as provided in Section 15.1.3 shall be provided in writing and shall be deemed to have been duly served only if delivered to the designated representative of the party to whom the notice is addressed by certified or registered mail, or by courier providing proof of delivery.

§ 1.7 Digital Data Use and Transmission

The parties shall agree upon protocols governing the transmission and use of Instruments of Service or any other information or documentation in digital form. ~~The parties will use AIA Document E203™–2013, Building Information Modeling and Digital Data Exhibit, to establish the protocols for the development, use, transmission, and exchange of digital data.~~

§ 1.8 Building Information Models Use and Reliance

Any use of, or reliance on, all or a portion of a building information model without agreement to protocols governing the use of, and reliance on, the information contained in the model and without having those protocols set forth in AIA Document E203™–2013, Building Information Modeling and Digital Data Exhibit, and the requisite AIA Document G202™–2013, Project Building Information Modeling Protocol Form, shall be at the using or relying party’s sole risk and without liability to the other party and its contractors or consultants, the authors of, or contributors to, the building information model, and each of their agents and employees.

ARTICLE 2 OWNER

§ 2.1 General

§ 2.1.1 The Owner is the person or entity identified as such in the Agreement and is referred to throughout the Contract Documents as if singular in number. The Owner shall designate in writing a representative who shall have express authority to bind the Owner with respect to all matters requiring the Owner’s approval or authorization. Except as otherwise provided in Section 4.2.1, the Construction Manager and the Architect do not have such authority. The term “Owner” means the Owner or the Owner’s authorized representative.

§ 2.1.2 The Owner shall furnish to the Contractor, within fifteen days after receipt of a written request, information necessary and relevant for the Contractor to evaluate, give notice of, or enforce mechanic’s lien rights. Such information shall include a correct statement of the record legal title to the property on which the Project is located, usually referred to as the site, and the Owner’s interest therein.

§ 2.2 Evidence of the Owner's Financial Arrangements

§ 2.2.1 Prior to commencement of the Work, and upon written request by the Contractor, the Owner shall furnish to the Contractor reasonable evidence that the Owner has made financial arrangements to fulfill the Owner's obligations under the Contract. The Contractor shall have no obligation to commence the Work until the Owner provides such evidence. If commencement of the Work is delayed under this Section 2.2.1, the Contract Time shall be extended appropriately.

§ 2.2.2 Following commencement of the Work and upon written request by the Contractor, the Owner shall furnish to the Contractor reasonable evidence that the Owner has made financial arrangements to fulfill the Owner's obligations under the Contract only if (1) the Owner fails to make payments to the Contractor as the Contract Documents require; (2) the Contractor identifies in writing a reasonable concern regarding the Owner's ability to make payment when due; or (3) a change in the Work materially changes the Contract Sum. If the Owner fails to provide such evidence, as required, within fourteen days of the Contractor's request, the Contractor may immediately stop the Work and, in that event, shall notify the Owner that the Work has stopped. However, if the request is made because a change in the Work materially changes the Contract Sum under (3) above, the Contractor may immediately stop only that portion of the Work affected by the change until reasonable evidence is provided. If the Work is stopped under this Section 2.2.2, the Contract Time shall be extended appropriately and the Contract Sum shall be increased by the amount of the Contractor's reasonable costs of shutdown, delay and start-up, plus interest as provided in the Contract Documents.

§ 2.2.3 After the Owner furnishes evidence of financial arrangements under this Section 2.2, the Owner shall not materially vary such financial arrangements without prior notice to the Contractor.

§ 2.2.4 Where the Owner has designated information furnished under this Section 2.2 as "confidential," the Contractor shall keep the information confidential and shall not disclose it to any other person. However, the Contractor may disclose "confidential" information, after seven (7) days' notice to the Owner, where disclosure is required by law, including a subpoena or other form of compulsory legal process issued by a court or governmental entity, or by court or arbitrator(s) order. The Contractor may also disclose "confidential" information to its employees, consultants, sureties, Subcontractors and their employees, Sub-subcontractors, and others who need to know the content of such information solely and exclusively for the Project and who agree to maintain the confidentiality of such information.

§ 2.3 Information and Services Required of the Owner

§ 2.3.1 Except for permits and fees that are the responsibility of the Contractor under the Contract Documents, including those required under Section 3.7.1, the Owner shall secure and pay for necessary approvals, easements, assessments and charges required for construction, use or occupancy of permanent structures or for permanent changes in existing facilities. Unless otherwise provided under the Contract Documents, the Owner, assisted by the Construction Manager, shall secure and pay for the building permit.

§ 2.3.2 The Owner shall retain an architect lawfully licensed to practice architecture, or an entity lawfully practicing architecture, in the jurisdiction where the Project is located. That person or entity is identified as the Architect in the Agreement and is referred to throughout the Contract Documents as if singular in number.

§ 2.3.3 The Owner shall retain a construction manager adviser lawfully practicing construction management in the jurisdiction where the Project is located. That person or entity is identified as the Construction Manager in the Agreement and is referred to throughout the Contract Documents as if singular in number.

§ 2.3.4 If the employment of the Construction Manager or Architect terminates, the Owner shall employ a successor construction manager or architect to whom the Contractor has no reasonable objection and whose status under the Contract Documents shall be that of the Construction Manager or Architect, respectively.

§ 2.3.5 The Owner shall furnish the as-built documentation from the previous demolition project at the site surveys describing physical characteristics, legal limitations and utility locations for the site of the Project, and a legal description of the site. The Contractor shall be entitled to rely on the accuracy of information furnished by the Owner but shall exercise proper precautions relating to the safe performance of the Work.

§ 2.3.6 The Owner shall furnish information or services required of the Owner by the Contract Documents with reasonable promptness. The Owner shall also furnish any other information or services under the Owner's control and relevant to the Contractor's performance of the Work with reasonable promptness after receiving the Contractor's written request for such information or services.

§ 2.3.7 Unless otherwise provided in the Contract Documents, the Owner shall furnish to the Contractor ~~one copy of~~ the Contract Documents in electronic pdf format for purposes of making paper documents, at the Contractor's cost, reproductions pursuant to Section 1.5.2 and provisions contained in Division 01 Sections.

§ 2.3.8 The Owner shall forward all communications to the Contractor through the Construction Manager. Other communication shall be made as set forth in Section 4.2.6.

§ 2.4 Owner's Right to Stop the Work

If the Contractor fails to correct Work that is not in accordance with the requirements of the Contract Documents as required by Section 12.2 or repeatedly fails to carry out Work in accordance with the Contract Documents, the Owner may issue a written order to the Contractor to stop the Work, or any portion thereof, until the cause for such order has been eliminated; however, the right of the Owner to stop the Work shall not give rise to a duty on the part of the Owner to exercise this right for the benefit of the Contractor or any other person or entity, except to the extent required by Section 6.1.3.

§ 2.5 Owner's Right to Carry Out the Work

If the Contractor defaults or neglects to carry out the Work in accordance with the Contract Documents and fails within a ten-day period after receipt of notice from the Owner to commence and continue correction of such default or neglect with diligence and promptness, the Owner may, without prejudice to other remedies the Owner may have, correct such default or neglect. Such action by the Owner and amounts charged to the Contractor are both subject to review by the Construction Manager and prior approval of the Architect, and the Construction Manager or Architect may, pursuant to Section 9.5.1, withhold or nullify a Certificate for Payment in whole or in part, to the extent reasonably necessary to reimburse the Owner for the reasonable cost of correcting such deficiencies, including Owner's expenses and compensation for the Construction Manager's and Architect's and their respective consultants' additional services made necessary by such default, neglect, or failure. If current and future payments are not sufficient to cover such amounts, the Contractor shall pay the difference to the Owner. If the Contractor disagrees with the actions of the Owner or the Architect, or the amounts claimed as costs to the Owner, the Contractor may file a Claim pursuant to Article 15.

ARTICLE 3 CONTRACTOR

§ 3.1 General

§ 3.1.1 The Contractor is the person or entity identified as such in the Agreement and is referred to throughout the Contract Documents as if singular in number. The Contractor shall be lawfully licensed, if required in the jurisdiction where the Project is located. The Contractor shall designate in writing a representative who shall have express authority to bind the Contractor with respect to all matters under this Contract. The term "Contractor" means the Contractor or the Contractor's authorized representative.

§ 3.1.2 The Contractor shall perform the Work in accordance with the Contract Documents.

§ 3.1.3 The Contractor shall not be relieved of its obligations to perform the Work in accordance with the Contract Documents either by activities or duties of the Construction Manager or Architect in their administration of the Contract, or by tests, inspections or approvals required or performed by persons or entities other than the Contractor.

§ 3.2 Review of Contract Documents and Field Conditions by Contractor

§ 3.2.1 Execution of the Contract by the Contractor is a representation that the Contractor has visited the site, become generally familiar with local conditions under which the Work is to be performed, and correlated personal observations with requirements of the Contract Documents.

§ 3.2.2 Because the Contract Documents are complementary, the Contractor shall, before starting each portion of the Work, carefully study and compare the various Contract Documents relative to that portion of the Work, as well as the information furnished by the Owner pursuant to Section 2.3.5, shall take field measurements of any existing conditions related to that portion of the Work, and shall observe any conditions at the site affecting it. These obligations are for the purpose of facilitating coordination and construction by the Contractor and are not for the purpose of discovering errors, omissions, or inconsistencies in the Contract Documents; however, the Contractor shall promptly report to the Construction Manager and Architect any errors, inconsistencies or omissions discovered by or made known to the Contractor as a request for information submitted to the Construction Manager in such form as the Construction Manager and Architect may require. It is recognized that the Contractor's review is made in the

Contractor's capacity as a contractor and not as a licensed design professional, unless otherwise specifically provided in the Contract Documents.

§ 3.2.3 The Contractor is not required to ascertain that the Contract Documents are in accordance with applicable laws, statutes, ordinances, codes, rules and regulations, or lawful orders of public authorities, but the Contractor shall promptly report to the Construction Manager and Architect any nonconformity discovered by or made known to the Contractor as a request for information submitted to Construction Manager in such form as the Construction Manager and Architect may require.

§ 3.2.4 If the Contractor believes that additional cost or time is involved because of clarifications or instructions the Architect issues in response to the Contractor's notices or requests for information pursuant to Sections 3.2.2 or 3.2.3, the Contractor shall submit Claims as provided in Article 15. If the Contractor fails to perform the obligations of Sections 3.2.2 or 3.2.3, the Contractor shall pay such costs and damages to the Owner, subject to section 15.1.7, as would have been avoided if the Contractor had performed such obligations. If the Contractor performs those obligations, the Contractor shall not be liable to the Owner or Architect for damages resulting from errors, inconsistencies or omissions in the Contract Documents, for differences between field measurements or conditions and the Contract Documents, or for nonconformities of the Contract Documents to applicable laws, statutes, ordinances, codes, rules and regulations, and lawful orders of public authorities.

§ 3.3 Supervision and Construction Procedures

§ 3.3.1 The Contractor shall supervise and direct the Work, using the Contractor's best skill and attention. The Contractor shall be solely responsible for, and have control over, construction means, methods, techniques, sequences, and procedures, and for coordinating all portions of the Work under the Contract. If the Contract Documents give specific instructions concerning construction means, methods, techniques, sequences, or procedures, the Contractor shall evaluate the jobsite safety thereof and shall be solely responsible for the jobsite safety of such means, methods, techniques, sequences, or procedures. If the Contractor determines that such means, methods, techniques, sequences or procedures may not be safe, the Contractor shall give timely notice to the Owner, the Construction Manager, and the Architect, and shall propose alternative means, methods, techniques, sequences, or procedures. The Architect shall evaluate the proposed alternative solely for conformance with the design intent for the completed construction. The Construction Manager shall review the proposed alternative for sequencing, constructability, and coordination impacts on the other Contractors. Unless the Architect or the Construction Manager objects to the Contractor's proposed alternative, the Contractor shall perform the Work using its alternative means, methods, techniques, sequences, or procedures.

§ 3.3.2 The Contractor shall be responsible to the Owner for acts and omissions of the Contractor's employees, Subcontractors and their agents and employees, and other persons or entities performing portions of the Work for, or on behalf of, the Contractor or any of its Subcontractors.

§ 3.3.3 The Contractor shall be responsible for inspection of portions of the Project already performed to determine that such portions are in proper condition to receive subsequent Work.

§ 3.4 Labor and Materials

§ 3.4.1 Unless otherwise provided in the Contract Documents, the Contractor shall provide and pay for labor, materials, equipment, tools, construction equipment and machinery, water, heat, utilities, transportation, and other facilities and services necessary for proper execution and completion of the Work, whether temporary or permanent and whether or not incorporated or to be incorporated in the Work.

§ 3.4.2 Except in the case of minor changes in the Work approved by the Architect in accordance with Section 3.12.8 or ordered by the Architect in accordance with Section 7.4, the Contractor may make substitutions only with the consent of the Owner, after evaluation by the Architect, in consultation with the Construction Manager, and in accordance with a Change Order or Construction Change Directive.

§ 3.4.2.1 Whenever a material, article, device, piece of equipment or type of construction is identified on the Drawings or in the Specifications by reference to manufacturers' or vendors' names, trade names, catalog numbers, or similar specific information, it is so identified for the purpose of establishing a standard of quality. Proposed substitutions will be considered equally acceptable provided the material, article, device, piece of equipment or type of construction so proposed is completely described in submittals to the Architect and is, in the opinion of the Architect, of equal substance, appearance, and function. No substitute material shall be purchased or installed by the Contractor without

the Architect's written approval. Material that, in the Architect's opinion, is inferior to that specified or is unsuited for the intended use will be rejected. The Architect's decision regarding acceptance of equals shall be final.

§ 3.4.3 The Contractor shall enforce strict discipline and good order among the Contractor's employees and other persons carrying out the Work. The Contractor shall not permit employment of unfit persons or persons not properly skilled in tasks assigned to them.

§3.4.4 After the Contract has been executed, the Owner and Architect will consider a formal request for the substitution of specified products only under the conditions set forth in the Specifications, Division 01 General Requirements and herein. By making requests for substitutions the Contractor:

- .1 represents that the Contractor has personally investigated the proposed substitute product and determined that it is equal or superior in all respects to that specified;
- .2 represents that the Contractor will provide the same warranty for the substitution that the Contractor would provide for the specified product;
- .3 certifies that the cost data presented is complete and includes all related costs under this Contract except the Architect's redesign costs, and waives all claims for additional costs related to the substitution which subsequently become apparent; and
- .4 will coordinate the installation of the accepted substitution, making such changes as may be required for the Work to be complete in all respects.

§3.4.5 All work shall be executed in a thorough, substantial, workmanlike manner, in complete accordance with the manufacturer's most recent recommendations unless otherwise specified or permitted by the Architect. A sufficient force of competent workmen, foremen, and superintendents shall be employed at all times to permit the work to be pursued with diligence until completion.

§3.4.6 The Contractor shall provide the labor necessary to install his work within the terms of this Contract. The Owner assumes no responsibility for any expense due to so-called "overtime."

§ 3.5 Warranty

§ 3.5.1 The Contractor warrants to the Owner, Construction Manager, and Architect that materials and equipment furnished under the Contract will be of good quality and new unless the Contract Documents require or permit otherwise. The Contractor further warrants that the Work will conform to the requirements of the Contract Documents and will be free from defects, except for those inherent in the quality of the Work the Contract Documents require or permit. Work, materials, or equipment not conforming to these requirements may be considered defective. The Contractor's warranty excludes remedy for damage or defect caused by abuse, alterations to the Work not executed by the Contractor, improper or insufficient maintenance, improper operation, or normal wear and tear and normal usage. If required by the Construction Manager or Architect, the Contractor shall furnish satisfactory evidence as to the kind and quality of materials and equipment.

§ 3.5.2 All material, equipment, or other special warranties required by the Contract Documents shall be issued in the name of the Owner, or shall be transferable to the Owner, and shall commence in accordance with Section 9.8.4.

§ 3.6 Taxes

The Contractor shall pay sales, consumer, use and similar taxes for the Work or portions thereof provided by the Contractor that are legally enacted when bids are received or negotiations concluded, whether or not yet effective or merely scheduled to go into effect. The Owner is a tax exempt organization and will take title to materials used in the Project in order to permit tax exemption. The Owner will furnish a certificate with the Owner's Tax Exemption Number to the Contractor for use in purchasing tangible personal property required for the Project. This exemption shall not apply to machinery, equipment, tools, and other items purchased, leased, rented, or otherwise acquired for the Contractor's use even though the machinery, equipment, tools or other items are used either in part or entirely on the Work. This exemption shall apply only to materials fully incorporated into the Work of the Contract as accepted and approved by the Architect

§ 3.7 Permits, Fees, Notices, and Compliance with Laws

§ 3.7.1 Unless otherwise provided in the Contract Documents, the Owner, assisted by the Construction Manager, shall secure and pay for the building permit. The Contractor shall secure and pay for other permits, fees, licenses, and

inspections by government agencies necessary for proper execution and completion of the Work that are customarily secured after execution of the Contract and legally required at the time bids are received or negotiations concluded.

§ 3.7.2 The Contractor shall comply with and give notices required by applicable laws, statutes, ordinances, codes, rules and regulations, and lawful orders of public authorities applicable to performance of the Work.

§ 3.7.3 If the Contractor performs Work knowing it to be contrary to applicable laws, statutes, ordinances, codes, rules and regulations, or lawful orders of public authorities, the Contractor shall assume appropriate responsibility for such Work and shall bear the costs attributable to correction.

§ 3.7.4 **Concealed or Unknown Conditions.** If the Contractor encounters conditions at the site that are (1) subsurface or otherwise concealed physical conditions that differ materially from those indicated in the Contract Documents or (2) unknown physical conditions of an unusual nature that differ materially from those ordinarily found to exist and generally recognized as inherent in construction activities of the character provided for in the Contract Documents, the Contractor shall promptly provide notice to the Owner, Construction Manager, and the Architect before conditions are disturbed and in no event later than 14 days after first observance of the conditions. The Architect and Construction Manager will promptly investigate such conditions and, if the Architect, in consultation with the Construction Manager, determines that they differ materially and cause an increase or decrease in the Contractor's cost of, or time required for, performance of any part of the Work, will recommend that an equitable adjustment be made in the Contract Sum or Contract Time, or both. If the Architect, in consultation with the Construction Manager, determines that the conditions at the site are not materially different from those indicated in the Contract Documents and that no change in the terms of the Contract is justified, the Architect shall promptly notify the Owner, Construction Manager, and Contractor, stating the reasons. If the Owner or Contractor disputes the Architect's determination or recommendation, either party may submit a Claim as provided in Article 15.

§ 3.7.5 If, in the course of the Work, the Contractor encounters human remains or recognizes the existence of burial markers, archaeological sites or wetlands not indicated in the Contract Documents, the Contractor shall immediately suspend any operations that would affect them and shall notify the Owner, Construction Manager, and Architect. Upon receipt of such notice, the Owner shall promptly take any action necessary to obtain governmental authorization required to resume the operations. The Contractor shall continue to suspend such operations until otherwise instructed by the Owner but shall continue with all other operations that do not affect those remains or features. Requests for adjustments in the Contract Sum and Contract Time arising from the existence of such remains or features may be made as provided in Article 15.

§ 3.8 Allowances

§ 3.8.1 The Contractor shall include in the Contract Sum all allowances stated in the Contract Documents. Items covered by allowances shall be supplied for such amounts and by such persons or entities as the Owner may direct, but the Contractor shall not be required to employ persons or entities to whom the Contractor has reasonable objection.

§ 3.8.2 Unless otherwise provided in the Contract Documents:

- .1 allowances shall cover the cost to the Contractor of materials and equipment delivered at the site and all required taxes, less applicable trade discounts;
- .2 Contractor's costs for unloading and handling at the site, labor, installation costs, overhead, profit, and other expenses contemplated for stated allowance amounts shall be included in the Contract Sum but not in the allowances; and
- .3 whenever costs are more than or less than allowances, the Contract Sum shall be adjusted accordingly by Change Order. The amount of the Change Order shall reflect (1) the difference between actual costs and the allowances under Section 3.8.2.1 and (2) changes in Contractor's costs under Section 3.8.2.2.

§ 3.8.3 Materials and equipment under an allowance shall be selected by the Owner with reasonable promptness.

§ 3.9 Superintendent

§ 3.9.1 The Contractor shall employ a competent superintendent and necessary assistants who shall be in attendance at the Project site during performance of the Work. The superintendent shall represent the Contractor, and communications given to the superintendent shall be as binding as if given to the Contractor.

§ 3.9.2 The Contractor, as soon as practicable after award of the Contract, shall notify the Owner and Architect, through the Construction Manager, of the name and qualifications of a proposed superintendent. Within 14 days of

receipt of the information, the Construction Manager may notify the Contractor, stating whether the Owner, the Construction Manager, or the Architect (1) has reasonable objection to the proposed superintendent or (2) require additional time for review. Failure of the Construction Manager to provide notice within the 14-day period shall constitute notice of no reasonable objection.

§ 3.9.3 The Contractor shall not employ a proposed superintendent to whom the Owner, Construction Manager, or Architect has made reasonable and timely objection. The Contractor shall not change the superintendent without the Owner's consent, which shall not unreasonably be withheld or delayed.

§ 3.10 Contractor's Construction and Submittal Schedules

§ 3.10.1 The Contractor, promptly after being awarded the Contract, shall submit for the Owner's and Architect's information, and the Construction Manager's use in developing the Project schedule, a Contractor's construction schedule for the Work. The schedule shall contain detail appropriate for the Project, including (1) the date of commencement of the Work, interim schedule milestone dates, and the date of Substantial Completion; (2) an apportionment of the Work by construction activity; and (3) the time required for completion of each portion of the Work. The schedule shall provide for the orderly progression of the Work to completion and shall not exceed time limits current under the Contract Documents. The schedule shall be revised at appropriate intervals as required by the conditions of the Work and Project. The Contractor shall cooperate with the Construction Manager in scheduling and performing the Contractor's Work to avoid conflict with, and as to cause no delay in, the work or activities of other Contractors, or the construction or operations of the Owner's own forces or Separate Contractors.

§ 3.10.2 The Contractor, promptly after being awarded the Contract and thereafter as necessary to maintain a current submittal schedule, shall submit a submittal schedule for the Construction Manager's and Architect's approval. The Architect and Construction Manager's approval shall not be unreasonably delayed or withheld. The submittal schedule shall (1) be coordinated with the Contractor's construction schedule, and (2) allow the Construction Manager and Architect reasonable time to review submittals. If the Contractor fails to submit a submittal schedule, or fails to provide submittals in accordance with the approved submittal schedule, the Contractor shall not be entitled to any increase in Contract Sum or extension of Contract Time based on the time required for review of submittals.

§ 3.10.3 The Contractor shall participate with other Contractors, the Construction Manager, and the Owner in reviewing and coordinating all schedules for incorporation into the Project schedule that is prepared by the Construction Manager. The Contractor shall make revisions to the construction schedule and submittal schedule as deemed necessary by the Construction Manager to conform to the Project schedule.

§ 3.10.4 The Contractor shall perform the Work in general accordance with the most recent schedules submitted to the Owner, Construction Manager, and Architect, and incorporated into the approved Project schedule.

§ 3.11 Documents and Samples at the Site

The Contractor shall make available, at the Project site, the Contract Documents, including Change Orders, Construction Change Directives, and other Modifications, in good order and marked currently to indicate field changes and selections made during construction, and the approved Shop Drawings, Product Data, Samples, and similar required submittals. These shall be in electronic form or paper copy, available to the Construction Manager, Architect, and Owner, and delivered to the Construction Manager for submittal to the Owner upon completion of the Work as a record of the Work as constructed.

§ 3.12 Shop Drawings, Product Data, and Samples

§ 3.12.1 Shop Drawings are drawings, diagrams, schedules, and other data specially prepared for the Work by the Contractor or a Subcontractor, Sub-subcontractor, manufacturer, supplier, or distributor to illustrate some portion of the Work.

§ 3.12.2 Product Data are illustrations, standard schedules, performance charts, instructions, brochures, diagrams, and other information furnished by the Contractor to illustrate materials or equipment for some portion of the Work.

§ 3.12.3 Samples are physical examples that illustrate materials, equipment, or workmanship, and establish standards by which the Work will be judged.

§ 3.12.4 Shop Drawings, Product Data, Samples, and similar submittals are not Contract Documents. Their purpose is to demonstrate how the Contractor proposes to conform to the information given and the design concept expressed in

the Contract Documents for those portions of the Work for which the Contract Documents require submittals. Review by the Architect and Construction Manager is subject to the limitations of Sections 4.2.10 through 4.2.12. Informational submittals upon which the Construction Manager and Architect are not expected to take responsive action may be so identified in the Contract Documents. Submittals that are not required by the Contract Documents may be returned by the Construction Manager or Architect without action.

§ 3.12.5 The Contractor shall review for compliance with the Contract Documents, approve, and submit to the Construction Manager, Shop Drawings, Product Data, Samples, and similar submittals required by the Contract Documents, in accordance with the Project submittal schedule approved by the Construction Manager and Architect or, in the absence of an approved Project submittal schedule, with reasonable promptness and in such sequence as to cause no delay in the Work or in the activities of other Contractors, Separate Contractors, or the Owner's own forces. The Contractor shall cooperate with the Construction Manager in the coordination of the Contractor's Shop Drawings, Product Data, Samples, and similar submittals with related documents submitted by other Contractors.

§ 3.12.6 By submitting Shop Drawings, Product Data, Samples, and similar submittals, the Contractor represents to the Owner, Construction Manager, and Architect, that the Contractor has (1) reviewed and approved them, (2) determined and verified materials, field measurements and field construction criteria related thereto, or will do so, and (3) checked and coordinated the information contained within such submittals with the requirements of the Work and of the Contract Documents.

§ 3.12.7 The Contractor shall perform no portion of the Work for which the Contract Documents require submittal and review of Shop Drawings, Product Data, Samples, or similar submittals, until the respective submittal has been reviewed and approved by the Architect.

§ 3.12.8 The Work shall be in accordance with approved submittals except that the Contractor shall not be relieved of responsibility for deviations from the requirements of the Contract Documents by the Architect's approval of Shop Drawings, Product Data, Samples, or similar submittals, unless the Contractor has specifically notified the Construction Manager and Architect of such deviation at the time of submittal and (1) the Architect has given written approval to the specific deviation as a minor change in the Work, or (2) a Change Order or Construction Change Directive has been issued authorizing the deviation. The Contractor shall not be relieved of responsibility for errors or omissions in Shop Drawings, Product Data, Samples, or similar submittals, by the Architect's approval thereof.

§ 3.12.9 The Contractor shall direct specific attention, in writing or on resubmitted Shop Drawings, Product Data, Samples, or similar submittals, to revisions other than those requested by the Construction Manager and Architect on previous submittals. In the absence of such notice, the Architect's approval of a resubmission shall not apply to such revisions.

§ 3.12.10 The Contractor shall not be required to provide professional services that constitute the practice of architecture or engineering unless such services are specifically required by the Contract Documents for a portion of the Work or unless the Contractor needs to provide such services in order to carry out the Contractor's responsibilities for construction means, methods, techniques, sequences, and procedures. The Contractor shall not be required to provide professional services in violation of applicable law.

§ 3.12.10.1 If professional design services or certifications by a design professional related to systems, materials, or equipment are specifically required of the Contractor by the Contract Documents, the Owner and the Architect will specify all performance and design criteria that such services must satisfy. The Contractor shall be entitled to rely upon the adequacy and accuracy of the performance and design criteria provided in the Contract Documents. The Contractor shall cause such services or certifications to be provided by an appropriately licensed design professional, whose signature and seal shall appear on all drawings, calculations, specifications, certifications, Shop Drawings, and other submittals prepared by such professional. Shop Drawings, and other submittals related to the Work, designed or certified by such professional, if prepared by others, shall bear such professional's written approval when submitted to the Architect. The Owner, the Architect, and the Construction Manager shall be entitled to rely upon the adequacy and accuracy of the services, certifications, and approvals performed or provided by such design professionals, provided the Owner and Architect have specified to the Contractor the performance and design criteria that such services must satisfy. Pursuant to this Section 3.12.10, the Architect will review and approve or take other appropriate action on submittals only for the limited purpose of checking for conformance with information given and the design concept expressed in the Contract Documents. The Construction Manager shall review submittals for sequencing, constructability, and coordination impacts on other Contractors.

§ 3.12.10.2 If the Contract Documents require the Contractor's design professional to certify that the Work has been performed in accordance with the design criteria, the Contractor shall furnish such certifications to the Construction Manager and Architect at the time and in the form specified by the Architect.

§ 3.13 Use of Site

§ 3.13.1 The Contractor shall confine operations at the site to areas permitted by applicable laws, statutes, ordinances, codes, rules and regulations, lawful orders of public authorities, and the Contract Documents and shall not unreasonably encumber the site with materials or equipment.

§ 3.13.2 The Contractor shall coordinate the Contractor's operations with, and secure the approval of, the Construction Manager before using any portion of the site.

§ 3.14 Cutting and Patching

§ 3.14.1 The Contractor shall be responsible for cutting, fitting, or patching required to complete the Work or to make its parts fit together properly. All areas requiring cutting, fitting, or patching shall be restored to the condition existing prior to the cutting, fitting, or patching, unless otherwise required by the Contract Documents.

§ 3.14.2 The Contractor shall not damage or endanger a portion of the Work or fully or partially completed construction of the Owner, Separate Contractors, or of other Contractors by cutting, patching, or otherwise altering such construction, or by excavation. The Contractor shall not cut or otherwise alter construction by the Owner, Separate Contractors, or by other Contractors except with written consent of the Construction Manager, Owner, and such other Contractors or Separate Contractors. Consent shall not be unreasonably withheld. The Contractor shall not unreasonably withhold, from the Separate Contractors, other Contractors, or the Owner, its consent to cutting or otherwise altering the Work.

§ 3.15 Cleaning Up

§ 3.15.1 The Contractor shall keep the premises and surrounding area free from accumulation of waste materials and rubbish caused by operations under the Contract. At completion of the Work, the Contractor shall remove waste materials, rubbish, the Contractor's tools, construction equipment, machinery, and surplus materials from and about the Project.

§ 3.15.2 If the Contractor fails to clean up as provided in the Contract Documents, the Owner, or Construction Manager with the Owner's approval, may do so and the Owner shall be entitled to reimbursement from the Contractor.

§ 3.16 Access to Work

~~The Contractor shall provide the Owner, Construction Manager, and Architect with access to the Work in preparation and progress wherever located.~~ The Contractor shall provide the Owner and Architect and their authorized representatives access to the Work at all times for inspection whenever and wherever it is in preparation or progress. The Contractor shall provide facilities for such access.

§ 3.17 Royalties, Patents and Copyrights

The Contractor shall pay all royalties and license fees. The Contractor shall defend suits or claims for infringement of copyrights and patent rights and shall hold the Owner, Construction Manager, and Architect harmless from loss on account thereof, but shall not be responsible for defense or loss when a particular design, process, or product of a particular manufacturer or manufacturers is required by the Contract Documents, or where the copyright violations are contained in Drawings, Specifications, or other documents prepared by the Owner, Architect, or Construction Manager. However, if an infringement of a copyright or patent is discovered by, or made known to, the Contractor, the Contractor shall be responsible for the loss unless the information is promptly furnished to the Architect through the Construction Manager.

§ 3.18 Indemnification

§ 3.18.1 To the fullest extent permitted by law, the Contractor shall indemnify and hold harmless the Owner, Construction Manager, Architect, Construction Manager's and Architect's consultants, and agents and employees of any of them from and against claims, damages, losses, and expenses, including but not limited to attorneys' fees, arising out of or resulting from performance of the Work, provided that such claim, damage, loss, or expense is attributable to bodily injury, sickness, disease or death, or to injury to or destruction of tangible property (other than the Work itself), but only to the extent caused by the negligent acts or omissions of the Contractor, a Subcontractor,

anyone directly or indirectly employed by them, or anyone for whose acts they may be liable, regardless of whether or not such claim, damage, loss, or expense is caused in part by a party indemnified hereunder. Such obligation shall not be construed to negate, abridge, or reduce other rights or obligations of indemnity that would otherwise exist as to a party or person described in this Section 3.18.

§ 3.18.2 In claims against any person or entity indemnified under this Section 3.18 by an employee of the Contractor, a Subcontractor, anyone directly or indirectly employed by them, or anyone for whose acts they may be liable, the indemnification obligation under Section 3.18.1 shall not be limited by a limitation on amount or type of damages, compensation, or benefits payable by or for the Contractor or a Subcontractor under workers' compensation acts, disability benefit acts, or other employee benefit acts.

ARTICLE 4 ARCHITECT AND CONSTRUCTION MANAGER

§ 4.1 General

§ 4.1.1 The Architect is the person or entity retained by the Owner pursuant to Section 2.3.2 and identified as such in the Agreement.

§ 4.1.2 The Construction Manager is the person or entity retained by the Owner pursuant to Section 2.3.3 and identified as such in the Agreement.

§ 4.1.3 Duties, responsibilities, and limitations of authority of the Construction Manager and Architect as set forth in the Contract Documents shall not be restricted, modified, or extended without written consent of the Owner, Construction Manager, Architect, and Contractor. Consent shall not be unreasonably withheld.

§ 4.2 Administration of the Contract

§ 4.2.1 The Construction Manager and Architect will provide administration of the Contract as described in the Contract Documents and will be the Owner's representatives during construction until the date the Architect issues the final Certificate for Payment. The Construction Manager and Architect will have authority to act on behalf of the Owner only to the extent provided in the Contract Documents.

§ 4.2.2 The Architect will visit the site at intervals appropriate to the stage of construction, or as otherwise agreed with the Owner, to become generally familiar with the progress and quality of the portion of the Work completed, and to determine in general if the Work observed is being performed in a manner indicating that the Work, when fully completed, will be in accordance with the Contract Documents. However, the Architect will not be required to make exhaustive or continuous on-site inspections to check the quality or quantity of the Work. On the basis of the site visits, the Architect will keep the Owner and the Construction Manager reasonably informed about the progress and quality of the portion of the Work completed, and promptly report to the Owner and Construction Manager known deviations from the Contract Documents and defects and deficiencies observed in the Work.

§ 4.2.3 The Construction Manager shall provide one or more representatives who shall be in attendance at the Project site whenever the Work is being performed. The Construction Manager will determine in general if the Work observed is being performed in accordance with the Contract Documents, will keep the Owner and Architect reasonably informed of the progress of the Work, and will promptly report to the Owner and Architect known deviations from the Contract Documents and the most recent Project schedule, and defects and deficiencies observed in the Work.

§ 4.2.4 The Construction Manager will schedule and coordinate the activities of the Contractor and other Contractors in accordance with the latest approved Project schedule.

§ 4.2.5 The Construction Manager, except to the extent required by Section 4.2.4, and Architect will not have control over, charge of, or responsibility for, the construction means, methods, techniques, sequences or procedures, or for the safety precautions and programs in connection with the Work, since these are solely the Contractor's rights and responsibilities under the Contract Documents, and neither will be responsible for the Contractor's failure to perform the Work in accordance with the requirements of the Contract Documents. Neither the Construction Manager nor the Architect will have control over or charge of, or be responsible for acts or omissions of, the Contractor, Subcontractors, or their agents or employees, or of any other persons or entities performing portions of the Work.

§ 4.2.6 Communications. The Owner shall communicate with the Contractor and the Construction Manager's consultants through the Construction Manager about matters arising out of or relating to the Contract Documents. The Owner and Construction Manager shall include the Architect in all communications that relate to or affect the

Architect's services or professional responsibilities. The Owner shall promptly notify the Architect of the substance of any direct communications between the Owner and the Construction Manager otherwise relating to the Project. Communications by and with the Architect's consultants shall be through the Architect. Communications by and with Subcontractors and suppliers shall be through the Contractor. Communications by and with other Contractors shall be through the Construction Manager. Communications by and with the Owner's own forces and Separate Contractors shall be through the Owner. The Contract Documents may specify other communication protocols.

§ 4.2.7 The Construction Manager and Architect will review and certify all Applications for Payment by the Contractor, in accordance with the provisions of Article 9.

§ 4.2.8 The Architect and Construction Manager have authority to reject Work that does not conform to the Contract Documents, and will notify each other about the rejection. Whenever the Construction Manager considers it necessary or advisable, the Construction Manager will have authority to require inspection or testing of the Work in accordance with Sections 13.4.2 and 13.4.3, upon written authorization of the Owner, whether or not the Work is fabricated, installed or completed. The foregoing authority of the Construction Manager will be subject to the provisions of Sections 4.2.18 through 4.2.20 inclusive, with respect to interpretations and decisions of the Architect. However, neither the Architect's nor the Construction Manager's authority to act under this Section 4.2.8 nor a decision made by either of them in good faith either to exercise or not to exercise such authority shall give rise to a duty or responsibility of the Architect or the Construction Manager to the Contractor, Subcontractors, suppliers, their agents or employees, or other persons performing any of the Work.

§ 4.2.9 Utilizing the submittal schedule provided by the Contractor, the Construction Manager shall prepare, and revise as necessary, a Project submittal schedule incorporating information from other Contractors, the Owner, Owner's consultants, Owner's Separate Contractors and vendors, governmental agencies, and participants in the Project under the management of the Construction Manager. The Project submittal schedule and any revisions shall be submitted to the Architect for approval.

§ 4.2.10 The Construction Manager will receive and promptly review for conformance with the submittal requirements of the Contract Documents, all submittals from the Contractor such as Shop Drawings, Product Data, and Samples. Where there are other Contractors, the Construction Manager will also check and coordinate the information contained within each submittal received from the Contractor and other Contractors, and transmit to the Architect those recommended for approval. By submitting Shop Drawings, Product Data, Samples, and similar submittals, the Construction Manager represents to the Owner and Architect that the Construction Manager has reviewed and recommended them for approval. The Construction Manager's actions will be taken in accordance with the Project submittal schedule approved by the Architect or, in the absence of an approved Project submittal schedule, with reasonable promptness while allowing sufficient time to permit adequate review by the Architect.

§ 4.2.11 The Architect will review and approve, or take other appropriate action upon, the Contractor's submittals such as Shop Drawings, Product Data, and Samples, but only for the limited purpose of checking for conformance with information given and the design concept expressed in the Contract Documents. The Architect's action will be taken in accordance with the submittal schedule approved by the Architect or, in the absence of an approved submittal schedule, with reasonable promptness while allowing sufficient time in the Architect's professional judgment to permit adequate review. Upon the Architect's completed review, the Architect shall transmit its submittal review to the Construction Manager.

§ 4.2.12 Review of the Contractor's submittals by the Construction Manager and Architect is not conducted for the purpose of determining the accuracy and completeness of other details such as dimensions and quantities, or for substantiating instructions for installation or performance of equipment or systems, all of which remain the responsibility of the Contractor as required by the Contract Documents. The Construction Manager and Architect's review of the Contractor's submittals shall not relieve the Contractor of the obligations under Sections 3.3, 3.5, and 3.12. The Construction Manager and Architect's review shall not constitute approval of safety precautions or of any construction means, methods, techniques, sequences, or procedures. The Architect's approval of a specific item shall not indicate approval of an assembly of which the item is a component.

§ 4.2.13 The Construction Manager will prepare Change Orders and Construction Change Directives.

§ 4.2.14 The Construction Manager and the Architect will take appropriate action on Change Orders or Construction Change Directives in accordance with Article 7, and the Architect will have authority to order minor changes in the

Work as provided in Section 7.4. The Architect, in consultation with the Construction Manager, will investigate and make determinations and recommendations regarding concealed and unknown conditions as provided in Section 3.7.4.

§ 4.2.15 Utilizing the documents provided by the Contractor, the Construction Manager will maintain at the site for the Owner one copy of all Contract Documents, approved Shop Drawings, Product Data, Samples, and similar required submittals, in good order and marked currently to record all changes and selections made during construction. These will be available to the Architect and the Contractor, and will be delivered to the Owner upon completion of the Project.

§ 4.2.16 The Construction Manager will assist the Architect in conducting inspections to determine the date or dates of Substantial Completion and the date of final completion; issue Certificates of Substantial Completion in conjunction with the Architect pursuant to Section 9.8; and receive and forward to the Owner written warranties and related documents required by the Contract and assembled by the Contractor pursuant to Section 9.10. The Construction Manager will forward to the Architect a final Application and Certificate for Payment or final Project Application and Project Certificate for Payment upon the Contractor's compliance with the requirements of the Contract Documents.

§ 4.2.17 If the Owner and Architect agree, the Architect will provide one or more Project representatives to assist in carrying out the Architect's responsibilities at the site. The Owner shall notify the Construction Manager of any change in the duties, responsibilities and limitations of authority of the Project representatives.

§ 4.2.18 The Architect will interpret and decide matters concerning performance under, and requirements of, the Contract Documents on written request of the Construction Manager, Owner, or Contractor through the Construction Manager. The Architect's response to such requests will be made in writing within any time limits agreed upon or otherwise with reasonable promptness.

§ 4.2.19 Interpretations and decisions of the Architect will be consistent with the intent of, and reasonably inferable from, the Contract Documents and will be in writing or in the form of drawings. When making such interpretations and decisions, the Architect will endeavor to secure faithful performance by both Owner and Contractor, will not show partiality to either, and will not be liable for results of interpretations or decisions so rendered in good faith.

§ 4.2.20 The Architect's decisions on matters relating to aesthetic effect will be final if consistent with the intent expressed in the Contract Documents.

§ 4.2.21 The Construction Manager will receive and review requests for information from the Contractor, and forward each request for information to the Architect, with the Construction Manager's recommendation. The Architect will review and respond in writing, through the Construction Manager, to requests for information about the Contract Documents. The Construction Manager's recommendation and the Architect's response to each request will be made in writing within any time limits agreed upon or otherwise with reasonable promptness. If appropriate, the Architect will prepare and issue supplemental Drawings and Specifications in response to the requests for information.

ARTICLE 5 SUBCONTRACTORS

§ 5.1 Definitions

§ 5.1.1 A Subcontractor is a person or entity who has a direct contract with the Contractor to perform a portion of the Work at the site. The term "Subcontractor" is referred to throughout the Contract Documents as if singular in number and means a Subcontractor or an authorized representative of the Subcontractor. The term "Subcontractor" does not include other Contractors or Separate Contractors or the subcontractors of other Contractors or Separate Contractors.

§ 5.1.2 A Sub-subcontractor is a person or entity who has a direct or indirect contract with a Subcontractor to perform a portion of the Work at the site. The term "Sub-subcontractor" is referred to throughout the Contract Documents as if singular in number and means a Sub-subcontractor or an authorized representative of the Sub-subcontractor.

§ 5.2 Award of Subcontracts and Other Contracts for Portions of the Work

§ 5.2.1 Unless otherwise stated in the Contract Documents, the Contractor, as soon as practicable after award of the Contract, shall notify the Construction Manager, for review by the Owner, Construction Manager and Architect, of the persons or entities proposed for each principal portion of the Work, including those who are to furnish materials or equipment fabricated to a special design. Within 14 days of receipt of the information, the Construction Manager may notify the Contractor whether the Owner, the Construction Manager or the Architect (1) has reasonable objection to

any such proposed person or entity or, (2) requires additional time for review. Failure of the Construction Manager to provide notice within the 14-day period shall constitute notice of no reasonable objection.

§ 5.2.2 The Contractor shall not contract with a proposed person or entity to whom the Owner, Construction Manager or Architect has made reasonable and timely objection. The Contractor shall not be required to contract with anyone to whom the Contractor has made reasonable objection.

§ 5.2.3 If the Owner, Construction Manager or Architect has reasonable objection to a person or entity proposed by the Contractor, the Contractor shall propose another to whom the Owner, Construction Manager or Architect has no reasonable objection. If the proposed but rejected Subcontractor was reasonably capable of performing the Work, the Contract Sum and Contract Time shall be increased or decreased by the difference, if any, occasioned by such change, and an appropriate Change Order shall be issued before commencement of the substitute Subcontractor's Work. However, no increase in the Contract Sum or Contract Time shall be allowed for such change unless the Contractor has acted promptly and responsively in submitting names as required.

§ 5.2.4 The Contractor shall not substitute a Subcontractor, person, or entity for one previously selected if the Owner, Construction Manager or Architect makes reasonable objection to such substitution.

§ 5.3 Subcontractual Relations

By appropriate written agreement, the Contractor shall require each Subcontractor, to the extent of the Work to be performed by the Subcontractor, to be bound to the Contractor by terms of the Contract Documents, and to assume toward the Contractor all the obligations and responsibilities, including the responsibility for safety of the Subcontractor's Work, that the Contractor, by these Contract Documents, assumes toward the Owner, Construction Manager and Architect. Each subcontract agreement shall preserve and protect the rights of the Owner, Construction Manager and Architect under the Contract Documents with respect to the Work to be performed by the Subcontractor so that subcontracting thereof will not prejudice such rights, and shall allow to the Subcontractor, unless specifically provided otherwise in the subcontract agreement, the benefit of all rights, remedies, and redress against the Contractor that the Contractor, by the Contract Documents, has against the Owner. Where appropriate, the Contractor shall require each Subcontractor to enter into similar agreements with Sub-subcontractors. The Contractor shall make available to each proposed Subcontractor, prior to the execution of the subcontract agreement, copies of the Contract Documents to which the Subcontractor will be bound, and, upon written request of the Subcontractor, identify to the Subcontractor terms and conditions of the proposed subcontract agreement that may be at variance with the Contract Documents. Subcontractors will similarly make copies of applicable portions of such documents available to their respective proposed Sub-subcontractors.

§ 5.4 Contingent Assignment of Subcontracts

§ 5.4.1 Each subcontract agreement for a portion of the Work is assigned by the Contractor to the Owner, provided that

- .1 assignment is effective only after termination of the Contract by the Owner for cause pursuant to Section 14.2 and only for those subcontract agreements that the Owner accepts by notifying the Subcontractor and Contractor; and
- .2 assignment is subject to the prior rights of the surety, if any, obligated under bond relating to the Contract.

When the Owner accepts the assignment of a subcontract agreement, the Owner assumes the Contractor's rights and obligations under the subcontract.

§ 5.4.2 Upon such assignment, if the Work has been suspended for more than 30 days, the Subcontractor's compensation shall be equitably adjusted for increases in cost resulting from the suspension.

§ 5.4.3 Upon assignment to the Owner under this Section 5.4, the Owner may further assign the subcontract to a successor Contractor or other entity. If the Owner assigns the subcontract to a successor Contractor or other entity, the Owner shall nevertheless remain legally responsible for all of the successor Contractor's obligations under the subcontract.

ARTICLE 6 CONSTRUCTION BY OWNER OR BY SEPARATE CONTRACTORS

§ 6.1 Owner's Right to Perform Construction with Own Forces and to Award Other Contracts

§ 6.1.1 The Owner reserves the right to perform construction or operations related to the Project with the Owner's own forces, and with Separate Contractors retained under Conditions of the Contract substantially similar to those of this Contract, including those provisions of the Conditions of the Contract related to insurance and waiver of subrogation.

§ 6.1.2 When the Owner performs construction or operations with the Owner's own forces or Separate Contractors, the Owner shall provide for coordination of such forces and Separate Contractors with the Work of the Contractor, who shall cooperate with them.

§ 6.1.3 Unless otherwise provided in the Contract Documents, when the Owner performs construction or operations related to the Project with the Owner's own forces or with Separate Contractors, the Owner or its Separate Contractors shall have the same obligations and rights that the Contractor has under the Conditions of the Contract, including, without excluding others, those stated in Article 3, this Article 6, and Articles 10, 11, and 12.

§ 6.2 Mutual Responsibility

§ 6.2.1 The Contractor shall afford the Owner's own forces, Separate Contractors, Construction Manager and other Contractors reasonable opportunity for introduction and storage of their materials and equipment and performance of their activities, and shall connect and coordinate the Contractor's construction and operations with theirs as required by the Contract Documents.

§ 6.2.2 If part of the Contractor's Work depends for proper execution or results upon construction or operations by the Owner's own forces, Separate Contractors or other Contractors, the Contractor shall, prior to proceeding with that portion of the Work, promptly notify the Construction Manager and Architect of apparent discrepancies or defects in the construction or operations by the Owner or Separate Contractor or other Contractors that would render it unsuitable for proper execution and results of the Contractor's Work. Failure of the Contractor to notify the Construction Manager and the Architect of apparent discrepancies or defects prior to proceeding with the Work shall constitute an acknowledgment that the Owner's or Separate Contractor's or other Contractors' completed or partially completed construction is fit and proper to receive the Contractor's Work. The Contractor shall not be responsible for discrepancies or defects in the construction or operations by the Owner or Separate Contractors or other Contractors that are not apparent.

§ 6.2.3 The Contractor shall reimburse the Owner for costs the Owner incurs, including costs that are payable to a Separate Contractors or to other Contractors, because of the Contractor's delays, improperly timed activities or defective construction. The Owner shall be responsible to the Contractor for costs the Contractor incurs because of ~~delays, improperly timed activities,~~ damage to the Work by the Owner's own forces, Separate Contractors, or other Contractors, or defective construction by the Owner's own forces, Separate Contractors, or other Contractors.

§ 6.2.4 The Contractor shall promptly remedy damage that the Contractor wrongfully causes to completed or partially completed construction, or to property of the Owner, Separate Contractors, or other Contractors as provided in Section 10.2.5.

§ 6.2.5 The Owner, Separate Contractors, and other Contractors shall have the same responsibilities for cutting and patching as are described for the Contractor in Section 3.14.

§ 6.3 Owner's Right to Clean Up

If a dispute arises among the Contractor, Separate Contractors, other Contractors, and the Owner as to the responsibility under their respective contracts for maintaining the premises and surrounding area free from waste materials and rubbish, the Owner may clean up and the Construction Manager, with notice to the Architect, will allocate the cost among those responsible.

ARTICLE 7 CHANGES IN THE WORK

§ 7.1 General

§ 7.1.1 Changes in the Work may be accomplished after execution of the Contract, and without invalidating the Contract, by Change Order, Construction Change Directive or order for a minor change in the Work, subject to the limitations stated in this Article 7 and elsewhere in the Contract Documents.

§ 7.1.2 A Change Order shall be based upon agreement among the Owner, Construction Manager, Architect and Contractor. A Construction Change Directive requires agreement by the Owner, Construction Manager and Architect and may or may not be agreed to by the Contractor. An order for a minor change in the Work may be issued by the Architect alone.

§ 7.1.3 Changes in the Work shall be performed under applicable provisions of the Contract Documents. The Contractor shall proceed promptly with changes in the Work, unless otherwise provided in the Change Order, Construction Change Directive, or order for a minor change in the Work.

§ 7.2 Change Orders

A Change Order is a written instrument prepared by the Construction Manager and signed by the Owner, Construction Manager, Architect, and Contractor, stating their agreement upon all of the following:

- .1 The change in the Work;
- .2 The amount of the adjustment, if any, in the Contract Sum; and
- .3 The extent of the adjustment, if any, in the Contract Time.

§ 7.3 Construction Change Directives

§ 7.3.1 A Construction Change Directive is a written order prepared by the Construction Manager and signed by the Owner, Construction Manager and Architect, directing a change in the Work prior to agreement on adjustment, if any, in the Contract Sum or Contract Time, or both. The Owner may by Construction Change Directive, without invalidating the Contract, order changes in the Work within the general scope of the Contract consisting of additions, deletions, or other revisions, the Contract Sum and Contract Time being adjusted accordingly.

§ 7.3.2 A Construction Change Directive shall be used in the absence of total agreement on the terms of a Change Order.

§ 7.3.3 If the Construction Change Directive provides for an adjustment to the Contract Sum, the adjustment shall be based on one of the following methods:

- .1 Mutual acceptance of a lump sum properly itemized and supported by sufficient substantiating data to permit evaluation;
- .2 Unit prices stated in the Contract Documents or subsequently agreed upon;
- .3 Cost to be determined in a manner agreed upon by the parties and a mutually acceptable fixed or percentage fee; or
- .4 As provided in Section 7.3.4.

§ 7.3.4 If the Contractor does not respond promptly or disagrees with the method for adjustment in the Contract Sum, the Construction Manager shall determine the adjustment on the basis of reasonable expenditures and savings of those performing the Work attributable to the change, including, in case of an increase in the Contract Sum, an amount for overhead and profit as set forth ~~below in the Agreement, or if no such amount is set forth in the Agreement, a reasonable amount.~~ In such case, and also under Section 7.3.3.3, the Contractor shall keep and present, in such form as the Construction Manager may prescribe, an itemized accounting together with appropriate supporting data. Unless otherwise provided in the Contract Documents, costs for the purposes of this Section 7.3.4 shall be limited to the following:

- .1 Costs of labor, including applicable payroll taxes, fringe benefits required by agreement or custom, workers' compensation insurance, and other employee costs approved by the Construction Manager and Architect;
- .2 Costs of materials, supplies, and equipment, including cost of transportation, whether incorporated or consumed;
- .3 Rental costs of machinery and equipment, exclusive of hand tools, whether rented from the Contractor or others;
- .4 Costs of premiums for all bonds and insurance, permit fees, and sales, use, or similar taxes, directly related to the change; and
- .5 Costs of supervision and field office personnel directly attributable to the change.
- .6 The allowance for overhead and profit included in the total cost to the Owner shall be based on the following schedule:

.1 For the Contractor, for Work performed by the Contractor's own forces, mark-up shall not exceed 10 percent of the value of overhead and profit.

.2 For the Contractor, for Work performed by the Contractor's Subcontractor, 5 percent of the amount due the Subcontractor.

.3 For each Subcontractor, or Sub-subcontractor involved, for Work performed by that Subcontractor's own forces, mark-up shall not exceed 10 percent of the value of overhead and profit.

.4 For each Subcontractor, for Work performed by the Subcontractor's Sub-subcontractors, 5 percent of the amount due the Sub-subcontractor.

.5 Cost to which overhead and profit are to be applied shall be determined in accordance with Subparagraph 7.3.4.

.6 In order to facilitate checking of quotations for extras or credits, all proposals, except those so minor that their propriety can be seen by inspection, shall be accompanied by a complete itemization of costs including labor, materials and subcontracts. Labor and materials shall be itemized in the manner prescribed above. Where major cost items are Subcontracts, they shall be itemized also. Back-up data will be required to be submitted as well, in the form of proposals from subcontractors and/or written quotes for materials and equipment.

§ 7.3.5 If the Contractor disagrees with the adjustment in the Contract Time, the Contractor may make a Claim in accordance with applicable provisions of Article 15.

§ 7.3.6 Upon receipt of a Construction Change Directive, the Contractor shall promptly proceed with the change in the Work involved and advise the Construction Manager of the Contractor's agreement or disagreement with the method, if any, provided in the Construction Change Directive for determining the proposed adjustment in the Contract Sum or Contract Time.

§ 7.3.7 A Construction Change Directive signed by the Contractor indicates the Contractor's agreement therewith, including adjustment in Contract Sum and Contract Time or the method for determining them. Such agreement shall be effective immediately and shall be recorded as a Change Order.

§ 7.3.8 The amount of credit to be allowed by the Contractor to the Owner for a deletion or change that results in a net decrease in the Contract Sum shall be actual net cost as confirmed by the Construction Manager and Architect. When both additions and credits covering related Work or substitutions are involved in a change, the allowance for overhead and profit shall be figured on the basis of net increase, if any, with respect to that change.

§ 7.3.9 Pending final determination of the total cost of a Construction Change Directive to the Owner, the Contractor may request payment for Work completed under the Construction Change Directive in Applications for Payment. The Construction Manager and Architect will make an interim determination for purposes of monthly certification for payment for those costs and certify for payment the amount that the Construction Manager and Architect determine to be reasonably justified. The interim determination of cost shall adjust the Contract Sum on the same basis as a Change Order, subject to the right of either party to disagree and assert a Claim in accordance with Article 15.

§ 7.3.10 When the Owner and Contractor agree with a determination made by the Construction Manager and Architect concerning the adjustments in the Contract Sum and Contract Time, or otherwise reach agreement upon the adjustments, such agreement shall be effective immediately and the Construction Manager shall prepare a Change Order. Change Orders may be issued for all or any part of a Construction Change Directive.

§ 7.4 Minor Changes in the Work

The Architect may order minor changes in the Work that are consistent with the intent of the Contract Documents and do not involve an adjustment in the Contract Sum or an extension of the Contract Time. The Architect's order for minor changes shall be in writing. If the Contractor believes that the proposed minor change in the Work will affect the Contract Sum or Contract Time, the Contractor shall notify the Construction Manager and shall not proceed to implement the change in the Work. If the Contractor performs the Work set forth in the Architect's order for a minor change without prior notice to the Construction Manager that such change will affect the Contract Sum or Contract Time, the Contractor waives any adjustment to the Contract Sum or extension of the Contract Time.

ARTICLE 8 TIME

§ 8.1 Definitions

§ 8.1.1 Unless otherwise provided, Contract Time is the period of time, including authorized adjustments, allotted in the Contract Documents for Substantial Completion of the Work.

§ 8.1.2 The date of commencement of the Work is the date established in the Agreement.

§ 8.1.3 The date of Substantial Completion is the date certified by the Architect in accordance with Section 9.8.

§ 8.1.4 The term “day” as used in the Contract Documents shall mean calendar day unless otherwise specifically defined.

§ 8.2 Progress and Completion

§ 8.2.1 Time limits stated in the Contract Documents are of the essence of the Contract. By executing the Agreement, the Contractor confirms that the Contract Time is a reasonable period for performing the Work.

§ 8.2.2 The Contractor shall not knowingly, except by agreement or instruction of the Owner in writing, commence the Work prior to the effective date of insurance required to be furnished by the Contractor and Owner.

§ 8.2.3 The Contractor shall proceed expeditiously with adequate forces and shall achieve Substantial Completion within the Contract Time.

§ 8.3 Delays and Extensions of Time

§ 8.3.1 If the Contractor is delayed at any time in the commencement or progress of the Work by (1) an act or neglect of the Owner, Architect, Construction Manager, or an employee of any of them, or of the Owner’s own forces, Separate Contractors, or other Contractors; (2) by changes ordered in the Work; (3) by labor disputes, fire, unusual delay in deliveries, unavoidable casualties, adverse weather conditions documented in accordance with Section 15.1.6.2, or other causes beyond the Contractor’s control; (4) by delay authorized by the Owner pending mediation and binding dispute resolution; or (5) by other causes that the Contractor asserts and the Architect, based on the recommendation of the Construction Manager, determines justify delay, then the Contract Time shall be extended for such reasonable time as the Architect may determine.

§ 8.3.2 Claims relating to time shall be made in accordance with applicable provisions of Article 15.

~~§ 8.3.3 This Section 8.3 does not preclude recovery of damages for delay by either party under other provisions of the Contract Documents.~~ Contractor agrees to make no claims for damage for the delay in the performance of this Contract occasioned by any act, or failure to act, of Owner, Construction Manager or Architect, Architect's and Construction Manager's Consultants and Subconsultants, or any of their representatives, Contractor agrees that any such claim shall be compensated for solely by an extension of time. The Contractor hereby expressly assumes the risk of all delays to the Work and waives all claims for monetary damages or additional payment for delays to the Work, provided that the Contract Schedule be extended for excusable and acceptable delays as defined in 8.3.1 above.

§ 8.3.4 Should the Contractor sustain any damage or delay through any act or omission of any other contractor having a contract with the Owner or should the Contractor sustain any damage or delay through any act or omission of a subcontractor, the Contractor shall have no claim against the Owner, Architect or Construction Manager (if involved in the particular project) for such damage or delay, but shall solely have a right to recover or to claim such damage from the other contractor or subcontractor.

ARTICLE 9 PAYMENTS AND COMPLETION

§ 9.1 Contract Sum

§ 9.1.1 The Contract Sum is stated in the Agreement and, including authorized adjustments, is the total amount payable by the Owner to the Contractor for performance of the Work under the Contract Documents.

§ 9.1.2 If unit prices are stated in the Contract Documents or subsequently agreed upon, and if quantities originally contemplated are materially changed so that application of such unit prices to the actual quantities causes substantial inequity to the Owner or Contractor, the applicable unit prices shall be equitably adjusted.

§ 9.2 Schedule of Values

Where the Contract is based on a stipulated sum or Guaranteed Maximum Price, the Contractor shall submit a schedule of values to the Construction Manager, before the first Application for Payment, allocating the entire Contract Sum to the various portions of the Work. The schedule of values shall be prepared in the form, and supported by the data to substantiate its accuracy, required by the Construction Manager and the Architect. This schedule, unless objected to by the Construction Manager or Architect, shall be used as a basis for reviewing the Contractor’s

Applications for Payment. The Construction Manager shall forward to the Architect the Contractor's schedule of values. Any changes to the schedule of values shall be submitted to the Construction Manager and supported by such data to substantiate its accuracy as the Construction Manager and the Architect may require, and unless objected to by the Construction Manager or the Architect, shall be used as a basis for reviewing the Contractor's subsequent Applications for Payment.

§ 9.3 Applications for Payment

§ 9.3.1 At least fifteen days before the date established for each progress payment, the Contractor shall submit to the Construction Manager an itemized Application for Payment prepared in accordance with the schedule of values, if required under Section 9.2, for completed portions of the Work. The application shall be notarized, if required, and supported by all data substantiating the Contractor's right to payment that the Owner, Construction Manager or Architect require, such as copies of requisitions, and releases of waivers of lien from Subcontractors and suppliers, and shall reflect retainage if provided for in the Contract Documents.

§ 9.3.1.1 As provided in Section 7.3.9, such applications may include requests for payment on account of changes in the Work that have been properly authorized by Construction Change Directives, or by interim determinations of the Construction Manager and Architect, but not yet included in Change Orders.

§ 9.3.1.2 Applications for Payment shall not include requests for payment for portions of the Work for which the Contractor does not intend to pay a Subcontractor or supplier, unless such Work has been performed by others whom the Contractor intends to pay.

§ 9.3.1.3 Until Substantial Completion, the Owner will pay 95 percent of the amount due the Contractor on account of progress payments and shall hold the remaining 5 percent (5%) as retainage.

§ 9.3.1.4 When the work or major portions thereof as contemplated by the terms of the Contract are substantially completed, the Contractor shall submit to the Construction Manager a requisition for payment of the remaining amount of the Contract balance. Upon receipt of such requisition the Owner shall approve and promptly pay the remaining amount of the Contract balance less two times the value of any remaining items to be completed and an amount necessary to satisfy any claims, liens or judgements against the Contractor which have not been suitably discharged. Any claims, liens and judgements referred to in this clause shall pertain to the Project and shall be filed in accordance with the terms of the Contract, and applicable laws

§ 9.3.2 Unless otherwise provided in the Contract Documents, payments shall be made on account of materials and equipment delivered and suitably stored at the site for subsequent incorporation in the Work. If approved in advance by the Owner, payment may similarly be made for materials and equipment suitably stored off the site at a location agreed upon in writing. Payment for materials and equipment stored on or off the site shall be conditioned upon compliance by the Contractor with procedures satisfactory to the Owner to establish the Owner's title to such materials and equipment or otherwise protect the Owner's interest, and shall include the costs of applicable insurance, storage, and transportation to the site, for such materials and equipment stored off the site.

§ 9.3.3 The Contractor warrants that title to all Work covered by an Application for Payment will pass to the Owner no later than the time of payment. The Contractor further warrants that upon submittal of an Application for Payment all Work for which Certificates for Payment have been previously issued and payments received from the Owner shall, to the best of the Contractor's knowledge, information, and belief, be free and clear of liens, claims, security interests, or encumbrances, in favor of the Contractor, Subcontractors, suppliers, or other persons or entities that provided labor, materials and equipment relating to the Work.

§ 9.4 Certificates for Payment

§ 9.4.1 Where there is only one Contractor, the Construction Manager will, within seven days after the Construction Manager's receipt of the Contractor's Application for Payment, review the Application, certify the amount the Construction Manager determines is due the Contractor, and forward the Contractor's Application and Certificate for Payment to the Architect. Within seven days after the Architect receives the Contractor's Application for Payment from the Construction Manager, the Architect will either (1) issue to the Owner a Certificate for Payment, in the full amount of the Application for Payment, with a copy to the Construction Manager; or (2) issue to the Owner a Certificate for Payment for such amount as the Architect determines is properly due, and notify the Construction Manager and Owner of the Architect's reasons for withholding certification in part as provided in Section 9.5.1; or (3) withhold certification of the entire Application for Payment, and notify the Construction Manager and Owner of the

Architect's reason for withholding certification in whole as provided in Section 9.5.1. The Construction Manager will promptly forward to the Contractor the Architect's notice of withholding certification.

§ 9.4.2 Where there is more than one Contractor performing portions of the Project, the Construction Manager will, within seven days after the Construction Manager receives all of the Contractors' Applications for Payment: (1) review the Applications and certify the amount the Construction Manager determines is due each of the Contractors; (2) prepare a Summary of Contractors' Applications for Payment by combining information from each Contractor's application with information from similar applications for progress payments from the other Contractors; (3) prepare a Project Application and Certificate for Payment; (4) certify the amount the Construction Manager determines is due all Contractors; and (5) forward the Summary of Contractors' Applications for Payment and Project Application and Certificate for Payment to the Architect.

§ 9.4.2.1 Within seven days after the Architect receives the Project Application and Project Certificate for Payment and the Summary of Contractors' Applications for Payment from the Construction Manager, the Architect will either (1) issue to the Owner a Project Certificate for Payment, with a copy to the Construction Manager; or (2) issue to the Owner a Project Certificate for Payment for such amount as the Architect determines is properly due, and notify the Construction Manager and Owner of the Architect's reasons for withholding certification in part as provided in Section 9.5.1; or (3) withhold certification of the entire Project Application for Payment, and notify the Construction Manager and Owner of the Architect's reason for withholding certification in whole as provided in Section 9.5.1. The Construction Manager will promptly forward the Architect's notice of withholding certification to the Contractors.

§ 9.4.3 The Construction Manager's certification of an Application for Payment or, in the case of more than one Contractor, a Project Application and Certificate for Payment, shall be based upon the Construction Manager's evaluation of the Work and the data in the Application or Applications for Payment. The Construction Manager's certification will constitute a representation that, to the best of the Construction Manager's knowledge, information, and belief, the Work has progressed to the point indicated, the quality of the Work is in accordance with the Contract Documents, and that the Contractor is, or Contractors are, entitled to payment in the amount certified.

§ 9.4.4 The Architect's issuance of a Certificate for Payment or, in the case of more than one Contractor, Project Application and Certificate for Payment, shall be based upon the Architect's evaluation of the Work, the recommendation of the Construction Manager, and data in the Application for Payment or Project Application for Payment. The Architect's certification will constitute a representation that, to the best of the Architect's knowledge, information, and belief, the Work has progressed to the point indicated, the quality of the Work is in accordance with the Contract Documents, and that the Contractor is, or Contractors are, entitled to payment in the amount certified.

§ 9.4.5 The representations made pursuant to Sections 9.4.3 and 9.4.4 are subject to an evaluation of the Work for conformance with the Contract Documents upon Substantial Completion, to results of subsequent tests and inspections, to correction of minor deviations from the Contract Documents prior to completion, and to specific qualifications expressed by the Construction Manager or Architect.

§ 9.4.6 The issuance of a Certificate for Payment or a Project Certificate for Payment will not be a representation that the Construction Manager or Architect has (1) made exhaustive or continuous on-site inspections to check the quality or quantity of the Work; (2) reviewed construction means, methods, techniques, sequences, or procedures; (3) reviewed copies of requisitions received from Subcontractors and suppliers and other data requested by the Owner to substantiate the Contractor's right to payment; or (4) made examination to ascertain how or for what purpose the Contractor has used money previously paid on account of the Contract Sum.

§ 9.5 Decisions to Withhold Certification

§ 9.5.1 The Construction Manager or Architect may withhold a Certificate for Payment or Project Certificate for Payment in whole or in part, to the extent reasonably necessary to protect the Owner, if in the Construction Manager's or Architect's opinion the representations to the Owner required by Section 9.4.3 and 9.4.4 cannot be made. If the Construction Manager or Architect is unable to certify payment in the amount of the Application, the Construction Manager will notify the Contractor and Owner as provided in Section 9.4.1 and 9.4.2. If the Contractor, Construction Manager and Architect cannot agree on a revised amount, the Architect will promptly issue a Certificate for Payment or a Project Certificate for Payment for the amount for which the Architect is able to make such representations to the Owner. The Construction Manager or Architect may also withhold a Certificate for Payment or, because of subsequently discovered evidence, may nullify the whole or a part of a Certificate for Payment or Project Certificate for Payment previously issued, to such extent as may be necessary in the Construction Manager's or Architect's

opinion to protect the Owner from loss for which the Contractor is responsible, including loss resulting from the acts and omissions described in Section 3.3.2 because of

- .1 defective Work not remedied;
- .2 third party claims filed or reasonable evidence indicating probable filing of such claims, unless security acceptable to the Owner is provided by the Contractor;
- .3 failure of the Contractor to make payments properly to Subcontractors or suppliers for labor, materials or equipment;
- .4 reasonable evidence that the Work cannot be completed for the unpaid balance of the Contract Sum;
- .5 damage to the Owner or a Separate Contractor or other Contractor;
- .6 reasonable evidence that the Work will not be completed within the Contract Time, and that the unpaid balance would not be adequate to cover actual or liquidated damages for the anticipated delay; or
- .7 repeated failure to carry out the Work in accordance with the Contract Documents.

§ 9.5.2 When either party disputes the Architect's decision regarding a Certificate for Payment under Section 9.5.1, in whole or in part, that party may submit a Claim in accordance with Article 15.

§ 9.5.3 When the reasons for withholding certification are removed, certification will be made for amounts previously withheld.

§ 9.5.4 If the Architect or Construction Manager withholds certification for payment under Section 9.5.1, the Owner may, at its sole option, issue joint checks to the Contractor and to any Subcontractor or supplier to whom the Contractor failed to make payment for Work properly performed or material or equipment suitably delivered. If the Owner makes payments by joint check, the Owner shall notify the Architect and the Construction Manager, and both will reflect such payment on the next Certificate for Payment.

§ 9.6 Progress Payments

§ 9.6.1 After the Architect has issued a Certificate for Payment or Project Certificate for Payment, the Owner shall make payment in the manner and within the time provided in the Contract Documents, and shall so notify the Construction Manager and Architect.

§ 9.6.2 The Contractor shall pay each Subcontractor, no later than seven days after receipt of payment from the Owner, the amount to which the Subcontractor is entitled, reflecting percentages actually retained from payments to the Contractor on account of the Subcontractor's portion of the Work. The Contractor shall, by appropriate agreement with each Subcontractor, require each Subcontractor to make payments to Sub-subcontractors in a similar manner.

§ 9.6.3 The Construction Manager will, on request, furnish to a Subcontractor, if practicable, information regarding percentages of completion or amounts applied for by the Contractor and action taken thereon by the Owner, Construction Manager and Architect on account of portions of the Work done by such Subcontractor.

§ 9.6.4 The Owner has the right to request written evidence from the Contractor that the Contractor has properly paid Subcontractors and suppliers amounts paid by the Owner to the Contractor for subcontracted Work. If the Contractor fails to furnish such evidence within seven days, the Owner shall have the right to contact Subcontractors and suppliers to ascertain whether they have been properly paid. Neither the Owner, Construction Manager nor Architect shall have an obligation to pay, or to see to the payment of money to, a Subcontractor or supplier, except as may otherwise be required by law.

§ 9.6.5 The Contractor's payments to suppliers shall be treated in a manner similar to that provided in Sections 9.6.2, 9.6.3 and 9.6.4.

§ 9.6.6 A Certificate for Payment, a progress payment, or partial or entire use or occupancy of the Project by the Owner shall not constitute acceptance of Work not in accordance with the Contract Documents.

§ 9.6.7 Unless the Contractor provides the Owner with a payment bond in the full penal sum of the Contract Sum, payments received by the Contractor for Work properly performed by Subcontractors or provided by suppliers shall be held by the Contractor for those Subcontractors or suppliers who performed Work or furnished materials, or both, under contract with the Contractor for which payment was made by the Owner. Nothing contained herein shall require money to be placed in a separate account and not commingled with money of the Contractor, create any fiduciary

liability or tort liability on the part of the Contractor for breach of trust, or entitle any person or entity to an award of punitive damages against the Contractor for breach of the requirements of this provision.

§ 9.6.8 Provided the Owner has fulfilled its payment obligations under the Contract Documents, the Contractor shall defend and indemnify the Owner from all loss, liability, damage or expense, including reasonable attorney's fees and litigation expenses, arising out of any lien claim or other claim for payment by any Subcontractor or supplier of any tier. Upon receipt of notice of a lien claim or other claim for payment, the Owner shall notify the Contractor. If approved by the applicable court, when required, the Contractor may substitute a surety bond for the property against which the lien or other claim for payment has been asserted.

§ 9.7 Failure of Payment

If the Construction Manager and Architect do not issue a Certificate for Payment or a Project Certificate for Payment, through no fault of the Contractor, within fourteen days after the Construction Manager's receipt of the Contractor's Application for Payment, or if the Owner does not pay the Contractor within seven days after the date established in the Contract Documents, the amount certified by the Construction Manager and Architect or awarded by binding dispute resolution, then the Contractor may, upon seven additional days' notice to the Owner, Construction Manager and Architect, stop the Work until payment of the amount owing has been received. The Contract Time shall be extended appropriately and the Contract Sum shall be increased by the amount of the Contractor's reasonable costs of shutdown, delay and start-up, plus interest as provided for in the Contract Documents.

§ 9.8 Substantial Completion

§ 9.8.1 Substantial Completion is the stage in the progress of the Work when the Work or designated portion thereof is sufficiently complete in accordance with the Contract Documents so the Owner can occupy or utilize the Work for its intended use.

§ 9.8.2 When the Contractor considers that the Work, or a portion thereof which the Owner agrees to accept separately, is substantially complete, the Contractor shall notify the Construction Manager, and the Contractor and Construction Manager shall jointly prepare and submit to the Architect a comprehensive list of items to be completed or corrected prior to final payment. Failure to include an item on such list does not alter the responsibility of the Contractor to complete all Work in accordance with the Contract Documents.

§ 9.8.3 Upon receipt of the list, the Architect, assisted by the Construction Manager, will make an inspection to determine whether the Work or designated portion thereof is substantially complete. If the Architect's inspection discloses any item, whether or not included on the list, which is not sufficiently complete in accordance with the Contract Documents so that the Owner can occupy or utilize the Work or designated portion thereof for its intended use, the Contractor shall, before issuance of the Certificate of Substantial Completion, complete or correct such item upon notification by the Architect. In such case, the Contractor shall then submit a request for another inspection by the Architect, assisted by the Construction Manager, to determine Substantial Completion.

§ 9.8.4 When the Architect, assisted by the Construction Manager, determines that the Work of all of the Contractors, or designated portion thereof, is substantially complete, the Construction Manager will prepare, and the Construction Manager and Architect shall execute, a Certificate of Substantial Completion that shall establish the date of Substantial Completion; establish responsibilities of the Owner and Contractor for security, maintenance, heat, utilities, damage to the Work and insurance; and fix the time within which the Contractor shall finish all items on the list accompanying the Certificate. Warranties required by the Contract Documents shall commence on the date of Substantial Completion of the Work or designated portion thereof unless otherwise provided in the Certificate of Substantial Completion.

§ 9.8.5 The Certificate of Substantial Completion shall be submitted to the Owner and Contractor for their written acceptance of responsibilities assigned to them in the Certificate. Upon such acceptance, and consent of surety if any, the Owner shall make payment of retainage applying to the Work or designated portion thereof. Such payment shall be adjusted for Work that is incomplete or not in accordance with the requirements of the Contract Documents.

§ 9.9 Partial Occupancy or Use

§ 9.9.1 The Owner may occupy or use any completed or partially completed portion of the Work at any stage when such portion is designated by separate agreement with the Contractor, provided such occupancy or use is consented to by the insurer and authorized by public authorities having jurisdiction over the Project. Such partial occupancy or use may commence whether or not the portion is substantially complete, provided the Owner and Contractor have

accepted in writing the responsibilities assigned to each of them for payments, retainage if any, security, maintenance, heat, utilities, damage to the Work and insurance, and have agreed in writing concerning the period for correction of the Work and commencement of warranties required by the Contract Documents. When the Contractor considers a portion substantially complete, the Contractor and Construction Manager shall jointly prepare and submit a list to the Architect as provided under Section 9.8.2. Consent of the Contractor to partial occupancy or use shall not be unreasonably withheld. The stage of the progress of the Work shall be determined by written agreement between the Owner and Contractor or, if no agreement is reached, by decision of the Architect after consultation with the Construction Manager.

§ 9.9.2 Immediately prior to such partial occupancy or use, the Owner, Construction Manager, Contractor, and Architect shall jointly inspect the area to be occupied or portion of the Work to be used in order to determine and record the condition of the Work.

§ 9.9.3 Unless otherwise agreed upon, partial occupancy or use of a portion or portions of the Work shall not constitute acceptance of Work not complying with the requirements of the Contract Documents.

§ 9.10 Final Completion and Final Payment

§ 9.10.1 Upon completion of the Work, the Contractor shall forward to the Construction Manager a notice that the Work is ready for final inspection and acceptance, and shall also forward to the Construction Manager a final Contractor's Application for Payment. Upon receipt, the Construction Manager shall perform an inspection to confirm the completion of Work of the Contractor. The Construction Manager shall make recommendations to the Architect when the Work of all of the Contractors is ready for final inspection, and shall then forward the Contractors' notices and Application for Payment or Project Application for Payment, to the Architect, who will promptly make such inspection. When the Architect finds the Work acceptable under the Contract Documents and the Contract fully performed, the Construction Manager and Architect will promptly issue a final Certificate for Payment or Project Certificate for Payment stating that to the best of their knowledge, information and belief, and on the basis of their on-site visits and inspections, the Work has been completed in accordance with the Contract Documents and that the entire balance found to be due the Contractor and noted in the final Certificate is due and payable. The Construction Manager's and Architect's final Certificate for Payment or Project Certificate for Payment will constitute a further representation that conditions listed in Section 9.10.2 as precedent to the Contractor's being entitled to final payment have been fulfilled.

§ 9.10.2 Neither final payment nor any remaining retained percentage shall become due until the Contractor submits to the Architect through the Construction Manager (1) an affidavit that payrolls, bills for materials and equipment, and other indebtedness connected with the Work for which the Owner or the Owner's property might be responsible or encumbered (less amounts withheld by Owner) have been paid or otherwise satisfied, (2) a certificate evidencing that insurance required by the Contract Documents to remain in force after final payment is currently in effect, (3) a written statement that the Contractor knows of no reason that the insurance will not be renewable to cover the period required by the Contract Documents, (4) consent of surety, if any, to final payment (5) documentation of any special warranties, such as manufacturers' warranties or specific Subcontractor warranties, and (6) ~~if required by the Owner,~~ other data establishing payment or satisfaction of obligations, such as receipts and releases and waivers of liens, claims, security interests, or encumbrances arising out of the Contract, to the extent and in such form as may be designated by the Owner. If a Subcontractor refuses to furnish a release or waiver required by the Owner, the Contractor may furnish a bond satisfactory to the Owner to indemnify the Owner against such lien, claim, security interest, or encumbrance. If a lien, claim, security interest, or encumbrance remains unsatisfied after payments are made, the Contractor shall refund to the Owner all money that the Owner may be compelled to pay in discharging the lien, claim, security interest, or encumbrance, including all costs and reasonable attorneys' fees.

§ 9.10.3 If, after Substantial Completion of the Work, final completion thereof is materially delayed through no fault of the Contractor or by issuance of Change Orders affecting final completion, and the Construction Manager and Architect so confirm, the Owner shall, upon application by the Contractor and certification by the Construction Manager and Architect, and without terminating the Contract, make payment of the balance due for that portion of the Work fully completed, corrected, and accepted. If the remaining balance for Work not fully completed or corrected is less than retainage stipulated in the Contract Documents, and if bonds have been furnished, the written consent of the surety to payment of the balance due for that portion of the Work fully completed and accepted shall be submitted by the Contractor to the Architect through the Construction Manager prior to certification of such payment. Such payment shall be made under terms and conditions governing final payment, except that it shall not constitute a waiver of Claims.

- § 9.10.4 The making of final payment shall constitute a waiver of Claims by the Owner except those arising from
- .1 liens, Claims, security interests, or encumbrances arising out of the Contract and unsettled;
 - .2 failure of the Work to comply with the requirements of the Contract Documents;
 - .3 terms of special warranties required by the Contract Documents; or
 - .4 audits performed by the Owner, if permitted by the Contract Documents, after final payment.

§ 9.10.5 Acceptance of final payment by the Contractor, a Subcontractor, or a supplier, shall constitute a waiver of claims by that payee except those previously made in writing and identified by that payee as unsettled at the time of final Application for Payment.

ARTICLE 10 PROTECTION OF PERSONS AND PROPERTY

§ 10.1 Safety Precautions and Programs

The Contractor shall be responsible for initiating, maintaining, and supervising all safety precautions and programs in connection with the performance of the Contract. The Contractor shall submit the Contractor's safety program to the Construction Manager for review and coordination with the safety programs of other Contractors. The Construction Manager's responsibilities for review and coordination of safety programs shall not extend to direct control over or charge of the acts or omissions of the Contractors, Subcontractors, agents or employees of the Contractors or Subcontractors, or any other persons performing portions of the Work and not directly employed by the Construction Manager.

§ 10.2 Safety of Persons and Property

§ 10.2.1 The Contractor shall take reasonable precautions for safety of, and shall provide reasonable protection to prevent damage, injury, or loss to

- .1 employees on the Work and other persons who may be affected thereby;
- .2 the Work and materials and equipment to be incorporated therein, whether in storage on or off the site, under care, custody, or control of the Contractor, a Subcontractor, or a Sub-subcontractor;
- .3 other property at the site or adjacent thereto, such as trees, shrubs, lawns, walks, pavements, roadways, structures, and utilities not designated for removal, relocation, or replacement in the course of construction; and
- .4 construction or operations by the Owner, Separate Contractors, or other Contractors.

§ 10.2.2 The Contractor shall comply with, and give notices required by applicable laws, statutes, ordinances, codes, rules and regulations, and lawful orders of public authorities, bearing on safety of persons or property or their protection from damage, injury, or loss.

§ 10.2.3 The Contractor shall implement, erect, and maintain, as required by existing conditions and performance of the Contract, reasonable safeguards for safety and protection, including posting danger signs and other warnings against hazards; promulgating safety regulations; and notifying the owners and users of adjacent sites and utilities of the safeguards.

§ 10.2.4 When use or storage of explosives or other hazardous materials or equipment or unusual methods are necessary for execution of the Work, the Contractor shall exercise utmost care and carry on such activities under supervision of properly qualified personnel.

§ 10.2.5 The Contractor shall promptly remedy damage and loss (other than damage or loss insured under property insurance required by the Contract Documents) to property referred to in Sections 10.2.1.2, 10.2.1.3 and 10.2.1.4 caused in whole or in part by the Contractor, a Subcontractor, a Sub-subcontractor, or anyone directly or indirectly employed by any of them, or by anyone for whose acts they may be liable and for which the Contractor is responsible under Sections 10.2.1.2, 10.2.1.3 and 10.2.1.4. The Contractor may make a Claim for the cost to remedy the damage or loss to the extent such damage or loss is attributable to acts or omissions of the Owner, Construction Manager or Architect or anyone directly or indirectly employed by any of them, or by anyone for whose acts any of them may be liable, and not attributable to the fault or negligence of the Contractor. The foregoing obligations of the Contractor are in addition to the Contractor's obligations under Section 3.18.

§ 10.2.6 The Contractor shall designate a responsible member of the Contractor's organization at the site whose duty shall be the prevention of accidents. This person shall be the Contractor's superintendent unless otherwise designated by the Contractor in writing to the Owner, Construction Manager and Architect.

§ 10.2.7 The Contractor shall not permit any part of the construction or site to be loaded so as to cause damage or create an unsafe condition.

§ 10.2.8 Injury or Damage to Person or Property

If either party suffers injury or damage to person or property because of an act or omission of the other party, or of others for whose acts such party is legally responsible, notice of the injury or damage, whether or not insured, shall be given to the other party within a reasonable time not exceeding 21 days after discovery. The notice shall provide sufficient detail to enable the other party to investigate the matter.

§ 10.3 Hazardous Materials

§ 10.3.1 The Contractor is responsible for compliance with any requirements included in the Contract Documents regarding hazardous materials or substances. If the Contractor encounters a hazardous material or substance not addressed in the Contract Documents and if reasonable precautions will be inadequate to prevent foreseeable bodily injury or death to persons resulting from a material or substance, including but not limited to asbestos or polychlorinated biphenyl (PCB), encountered on the site by the Contractor, the Contractor shall, upon recognizing the condition, immediately stop Work in the affected area and notify the Owner, Construction Manager and Architect of the condition.

§ 10.3.2 Upon receipt of the Contractor's notice, the Owner shall obtain the services of a licensed laboratory to verify the presence or absence of the material or substance reported by the Contractor and, in the event such material or substance is found to be present, to cause it to be rendered harmless. Unless otherwise required by the Contract Documents, the Owner shall furnish in writing to the Contractor, Construction Manager and Architect the names and qualifications of persons or entities who are to perform tests verifying the presence or absence of the material or substance or who are to perform the task of removal or safe containment of the material or substance. The Contractor, the Construction Manager and the Architect will promptly reply to the Owner in writing stating whether or not any of them has reasonable objection to the persons or entities proposed by the Owner. If the Contractor, Construction Manager or Architect has an objection to a person or entity proposed by the Owner, the Owner shall propose another to whom the Contractor, the Construction Manager and the Architect have no reasonable objection. When the material or substance has been rendered harmless, Work in the affected area shall resume upon written agreement of the Owner and Contractor. By Change Order, the Contract Time shall be extended appropriately and the Contract Sum shall be increased by the amount of the Contractor's reasonable additional costs of shutdown, delay, and start-up.

§ 10.3.3 To the fullest extent permitted by law, the Owner shall indemnify and hold harmless the Contractor, Subcontractors, Construction Manager, Architect, their consultants, and agents and employees of any of them from and against claims, damages, losses, and expenses, including but not limited to attorneys' fees, arising out of or resulting from performance of the Work in the affected area if in fact the material or substance presents the risk of bodily injury or death as described in Section 10.3.1 and has not been rendered harmless, provided that such claim, damage, loss, or expense is attributable to bodily injury, sickness, disease or death, or to injury to or destruction of tangible property (other than the Work itself), except to the extent that such damage, loss, or expense is due to the fault or negligence of the party seeking indemnity.

§ 10.3.4 The Owner shall not be responsible under this Section 10.3 for hazardous materials or substances the Contractor brings to the site unless such materials or substances are required by the Contract Documents. The Owner shall be responsible for hazardous materials or substances required by the Contract Documents, except to the extent of the Contractor's fault or negligence in the use and handling of such materials or substances.

§ 10.3.5 The Contractor shall reimburse the Owner for the cost and expense the Owner incurs (1) for remediation of hazardous materials or substances the Contractor brings to the site and negligently handles, or (2) where the Contractor fails to perform its obligations under Section 10.3.1, except to the extent that the cost and expense are due to the Owner's fault or negligence.

§ 10.3.6 If, without negligence on the part of the Contractor, the Contractor is held liable by a government agency for the cost of remediation of a hazardous material or substance solely by reason of performing Work as required by the Contract Documents, the Owner shall reimburse the Contractor for all cost and expense thereby incurred.

§ 10.4 Emergencies

In an emergency affecting safety of persons or property, the Contractor shall act, at the Contractor's discretion, to prevent threatened damage, injury, or loss. Additional compensation or extension of time claimed by the Contractor on account of an emergency shall be determined as provided in Article 15 and Article 7.

ARTICLE 11 INSURANCE AND BONDS

§ 11.1 Contractor's Insurance and Bonds

~~§ 11.1.1 The Contractor shall purchase and maintain insurance of the types and limits of liability, containing the endorsements, and subject to the terms and conditions, as described and indicated in the "Owner's Insurance Requirements" included in the Project Manual in the Agreement or elsewhere in the Contract Documents. The Contractor shall purchase and maintain the required insurance from an insurance company or insurance companies lawfully authorized to issue insurance in the jurisdiction where the Project is located. The Owner, Construction Manager and Construction Manager's consultants, and the Architect and Architect's consultants, shall be named as additional insureds under the Contractor's commercial general liability policy or as otherwise described in the Contract Documents.~~

~~§ 11.1.2 The Contractor shall provide surety bonds of the types, for such penal sums, and subject to such terms and conditions as required by the Contract Documents. The Contractor shall purchase and maintain the required bonds from a company or companies lawfully authorized to issue surety bonds in the jurisdiction where the Project is located. The Contractor shall furnish a Performance Bond in an amount equal to one hundred percent (100%) of the Contract Sum as security for the faithful performance of this Contract and also a Payment Bond in an amount not less than one hundred percent (100%) of the Contract Sum as security for the payment of all persons performing labor on the Project under this Contract. Bonds shall be issued by a bonding company licensed in the State of New York, on the form included in the Contract Documents. The sufficiency of the bonds is subject to the approval of the Owner, and bonds which are deemed insufficient by the Owner may be rejected.~~

~~§ 11.1.2.1 The Contractor shall deliver the required bonds to the Owner within ten (10) days of issue date of Notice of Award of Contract. No work shall be performed by the Contractor until such bonds have been reviewed and acknowledged.~~

~~§ 11.1.2.2 The Contractor shall require the attorney-in-fact who executes the required bonds on behalf of the surety to affix thereto a certified and current copy of the power of attorney~~

§ 11.1.3 Upon the request of any person or entity appearing to be a potential beneficiary of bonds covering payment of obligations arising under the Contract, the Contractor shall promptly furnish a copy of the bonds or shall authorize a copy to be furnished.

§ 11.1.4 **Notice of Cancellation or Expiration of Contractor's Required Insurance.** Within three (3) business days of the date the Contractor becomes aware of an impending or actual cancellation or expiration of any insurance required by the Contract Documents, the Contractor shall provide notice directly to the Owner, and separately to the Construction Manager, of such impending or actual cancellation or expiration. Upon receipt of notice from the Contractor, the Owner shall, unless the lapse in coverage arises from an act or omission of the Owner, have the right to stop the Work until the lapse in coverage has been cured by the procurement of replacement coverage by the Contractor. The furnishing of notice by the Contractor shall not relieve the Contractor of any contractual obligation to provide any required coverage.

§ 11.2 Owner's Insurance

§ 11.2.1 The Owner shall purchase and maintain insurance of the types and limits of liability, containing the endorsements, and subject to the terms and conditions, as described and indicated in the "Owner's Insurance Requirements" included in the Project Manual ~~in the Agreement or elsewhere in the Contract Documents~~. The Owner shall purchase and maintain the required insurance from an insurance company or insurance companies lawfully authorized to issue insurance in the jurisdiction where the Project is located.

§ 11.2.2 **Failure to Purchase Required Property Insurance.** If the Owner fails to purchase and maintain the required property insurance, with all of the coverages and in the amounts described and indicated in the "Owner's Insurance Requirements" included in the Project Manual ~~in the Agreement or elsewhere in the Contract Documents~~, the Owner shall inform both the Contractor and the Construction Manager, separately and in writing, prior to commencement of the Work. Upon receipt of notice from the Owner, the Contractor may delay commencement of the Work and may obtain insurance that will protect the interests of the Contractor, Subcontractors, and Sub-Subcontractors in the Work.

When the failure to provide coverage has been cured or resolved, the Contract Sum and Contract Time shall be equitably adjusted. In the event the Owner fails to procure coverage, the Owner waives all rights against the Contractor, Subcontractors, and Sub-subcontractors to the extent the loss to the Owner would have been covered by the insurance to have been procured by the Owner. The cost of the insurance shall be charged to the Owner by a Change Order. If the Owner does not provide written notice, and the Contractor is damaged by the failure or neglect of the Owner to purchase or maintain the required insurance, the Owner shall reimburse the Contractor for all reasonable costs and damages attributable thereto.

§ 11.2.3 Notice of Cancellation or Expiration of Owner's Required Property Insurance. Within three (3) business days of the date the Owner becomes aware of an impending or actual cancellation or expiration of any property insurance required by the Contract Documents, the Owner shall provide notice directly to the Contractor, and separately to the Construction Manager, of such impending or actual cancellation or expiration. Unless the lapse in coverage arises from an act or omission of the Contractor: (1) the Contractor, upon receipt of notice from the Owner, shall have the right to stop the Work until the lapse in coverage has been cured by the procurement of replacement coverage by either the Owner or the Contractor; (2) the Contract Time and Contract Sum shall be equitably adjusted; and (3) the Owner waives all rights against the Contractor, Subcontractors, and Sub-subcontractors to the extent any loss to the Owner would have been covered by the insurance had it not expired or been cancelled. If the Contractor purchases replacement coverage, the cost of the insurance shall be charged to the Owner by an appropriate Change Order. The furnishing of notice by the Owner shall not relieve the Owner of any contractual obligation to provide required insurance.

§ 11.3 Waivers of Subrogation

§ 11.3.1 The Owner and Contractor waive all rights against (1) each other and any of their subcontractors, sub-subcontractors, agents, and employees, each of the other; (2) the Construction Manager and Construction Manager's consultants; (3) the Architect and Architect's consultants; (4) other Contractors and any of their subcontractors, sub-subcontractors, agents, and employees; and (5) Separate Contractors, if any, and any of their subcontractors, sub-subcontractors, agents, and employees, for damages caused by fire, or other causes of loss, to the extent those losses are covered by property insurance required by the Agreement or other property insurance applicable to the Project, except such rights as they have to proceeds of such insurance. The Owner or Contractor, as appropriate, shall require similar written waivers in favor of the individuals and entities identified above from the Construction Manager, Construction Manager's consultants, Architect, Architect's consultants, other Contractors, Separate Contractors, subcontractors, and sub-subcontractors. The policies of insurance purchased and maintained by each person or entity agreeing to waive claims pursuant to this Section 11.3.1 shall not prohibit this waiver of subrogation. This waiver of subrogation shall be effective as to a person or entity (1) even though that person or entity would otherwise have a duty of indemnification, contractual or otherwise, (2) even though that person or entity did not pay the insurance premium directly or indirectly, or (3) whether or not the person or entity had an insurable interest in the damaged property.

§ 11.3.2 If during the Project construction period the Owner insures properties, real or personal or both, at or adjacent to the site by property insurance under policies separate from those insuring the Project, or if after final payment property insurance is to be provided on the completed Project through a policy or policies other than those insuring the Project during the construction period, to the extent permissible by such policies, the Owner waives all rights in accordance with the terms of Section 11.3.1 for damages caused by fire or other causes of loss covered by this separate property insurance.

§ 11.4 Loss of Use, Business Interruption, and Delay in Completion Insurance

The Owner, at the Owner's option, may purchase and maintain insurance that will protect the Owner against loss of use of the Owner's property, or the inability to conduct normal operations, due to fire or other causes of loss. The Owner waives all rights of action against the Contractor, Architect, and Construction Manager for loss of use of the Owner's property, due to fire or other hazards however caused.

§ 11.5 Adjustment and Settlement of Insured Loss

§ 11.5.1 A loss insured under the property insurance required by the Agreement shall be adjusted by the Owner as fiduciary and made payable to the Owner as fiduciary for the insureds, as their interests may appear, subject to requirements of any applicable mortgagee clause and of Section 11.5.2. The Owner shall pay the Construction Manager, Architect and Contractor their just shares of insurance proceeds received by the Owner, and by appropriate agreements the Construction Manager, Architect and Contractor shall make payments to their consultants and Subcontractors in similar manner.

§ 11.5.2 Prior to settlement of an insured loss, the Owner shall notify the Contractor of the terms of the proposed settlement as well as the proposed allocation of the insurance proceeds. The Contractor shall have 14 days from receipt of notice to object to the proposed settlement or allocation of the proceeds. If the Contractor does not object, the Owner shall settle the loss and the Contractor shall be bound by the settlement and allocation. Upon receipt, the Owner shall deposit the insurance proceeds in a separate account and make the appropriate distributions. Thereafter, if no other agreement is made or the Owner does not terminate the Contract for convenience, the Owner and Contractor shall execute a Change Order for reconstruction of the damaged or destroyed Work in the amount allocated for that purpose. If the Contractor timely objects to either the terms of the proposed settlement or the allocation of the proceeds, the Owner may proceed to settle the insured loss, and any dispute between the Owner and Contractor arising out of the settlement or allocation of the proceeds shall be resolved pursuant to Article 15. Pending resolution of any dispute, the Owner may issue a Construction Change Directive for the reconstruction of the damaged or destroyed Work.

ARTICLE 12 UNCOVERING AND CORRECTION OF WORK

§ 12.1 Uncovering of Work

§ 12.1.1 If a portion of the Work is covered contrary to the Construction Manager's or Architect's request or to requirements specifically expressed in the Contract Documents, it must, if requested in writing by either, be uncovered for their examination and be replaced at the Contractor's expense without change in the Contract Time.

§ 12.1.2 If a portion of the Work has been covered that the Construction Manager or Architect has not specifically requested to examine prior to its being covered, the Construction Manager or Architect may request to see such Work and it shall be uncovered by the Contractor. If such Work is in accordance with the Contract Documents, the Contractor shall be entitled to an equitable adjustment to the Contract Sum and Contract Time as may be appropriate. If such Work is not in accordance with the Contract Documents, the costs of uncovering the Work, and the cost of correction, shall be at the Contractor's expense.

§ 12.2 Correction of Work

§ 12.2.1 Before Substantial Completion

The Contractor shall promptly correct Work rejected by the Construction Manager or Architect or failing to conform to the requirements of the Contract Documents, discovered before Substantial Completion, and whether or not fabricated, installed or completed. Costs of correcting such rejected Work, including additional testing and inspections, the cost of uncovering and replacement, and compensation for the Construction Manager's and Architect's services and expenses made necessary thereby, shall be at the Contractor's expense.

§ 12.2.2 After Substantial Completion

§ 12.2.2.1 In addition to the Contractor's obligations under Section 3.5, if, within one year after the date of Substantial Completion of the Work or designated portion thereof, or after the date for commencement of warranties established under Section 9.9.1, or by terms of any applicable special warranty required by the Contract Documents, any of the Work is found to be not in accordance with the requirements of the Contract Documents, the Contractor shall correct it promptly after receipt of notice from the Owner to do so, unless the Owner has previously given the Contractor a written acceptance of such condition. The Owner shall give such notice promptly after discovery of the condition. During the one-year period for correction of Work, if the Owner fails to notify the Contractor and give the Contractor an opportunity to make the correction, the Owner waives the rights to require correction by the Contractor and to make a claim for breach of warranty. If the Contractor fails to correct nonconforming Work within a reasonable time during that period after receipt of notice from the Owner, Construction Manager or Architect, the Owner may correct it in accordance with Section 2.5.

§ 12.2.2.2 The one-year period for correction of Work shall be extended with respect to portions of Work first performed after Substantial Completion by the period of time between Substantial Completion and the actual completion of that portion of the Work.

§ 12.2.2.3 The one-year period for correction of Work shall not be extended by corrective Work performed by the Contractor pursuant to this Section 12.2.

§ 12.2.3 The Contractor shall remove from the site portions of the Work that are not in accordance with the requirements of the Contract Documents and are neither corrected by the Contractor nor accepted by the Owner.

§ 12.2.4 The Contractor shall bear the cost of correcting destroyed or damaged construction of the Owner, Separate Contractors, or other Contractors, whether completed or partially completed, caused by the Contractor's correction or removal of Work that is not in accordance with the requirements of the Contract Documents.

§ 12.2.5 Nothing contained in this Section 12.2 shall be construed to establish a period of limitation with respect to other obligations the Contractor has under the Contract Documents. Establishment of the one-year period for correction of Work as described in Section 12.2.2 relates only to the specific obligation of the Contractor to correct the Work, and has no relationship to the time within which the obligation to comply with the Contract Documents may be sought to be enforced, nor to the time within which proceedings may be commenced to establish the Contractor's liability with respect to the Contractor's obligations other than specifically to correct the Work.

§ 12.3 Acceptance of Nonconforming Work

If the Owner prefers to accept Work that is not in accordance with the requirements of the Contract Documents, the Owner may do so instead of requiring its removal and correction, in which case the Contract Sum will be reduced as appropriate and equitable. Such adjustment shall be effected whether or not final payment has been made.

ARTICLE 13 MISCELLANEOUS PROVISIONS

§ 13.1 Governing Law

The Contract shall be governed by the law of the place where the Project is located excluding that jurisdiction's choice of law rules. If the parties have selected arbitration as the method of binding dispute resolution, the Federal Arbitration Act shall govern Section 15.4.

§ 13.2 Successors and Assigns

§ 13.2.1 The Owner and Contractor respectively bind themselves, their partners, successors, assigns, and legal representatives to covenants, agreements, and obligations contained in the Contract Documents. Except as provided in Section 13.2.2, neither party to the Contract shall assign the Contract as a whole without written consent of the other. If either party attempts to make an assignment without such consent, that party shall nevertheless remain legally responsible for all obligations under the Contract.

§ 13.2.2 The Owner may, without consent of the Contractor, assign the Contract to a lender providing construction financing for the Project, if the lender assumes the Owner's rights and obligations under the Contract Documents. The Contractor shall execute all consents reasonably required to facilitate the assignment.

§ 13.3 Rights and Remedies

§ 13.3.1 Duties and obligations imposed by the Contract Documents and rights and remedies available thereunder shall be in addition to and not a limitation of duties, obligations, rights, and remedies otherwise imposed or available by law.

§ 13.3.2 No action or failure to act by the Owner, Construction Manager, Architect, or Contractor shall constitute a waiver of a right or duty afforded them under the Contract, nor shall such action or failure to act constitute approval of or acquiescence in a breach thereunder, except as may be specifically agreed upon in writing.

§ 13.4 Tests and Inspections

§ 13.4.1 Tests, inspections, and approvals of portions of the Work shall be made as required by the Contract Documents and by applicable laws, statutes, ordinances, codes, rules, and regulations or lawful orders of public authorities. Unless otherwise provided, the Contractor shall make arrangements for such tests, inspections, and approvals with an independent testing laboratory or entity acceptable to the Owner, or with the appropriate public authority, and shall bear all related costs of tests, inspections, and approvals. The Contractor shall give the Construction Manager and Architect timely notice of when and where tests and inspections are to be made so that the Construction Manager and Architect may be present for such procedures. The Owner shall bear costs of tests, inspections, or approvals that do not become requirements until after bids are received or negotiations concluded. The Owner shall directly arrange and pay for tests, inspections, or approvals where building codes or applicable laws or regulations so require.

§ 13.4.2 If the Construction Manager, Architect, Owner, or public authorities having jurisdiction determine that portions of the Work require additional testing, inspection, or approval not included under Section 13.4.1, the Construction Manager and Architect will, upon written authorization from the Owner, instruct the Contractor to make arrangements for such additional testing, inspection, or approval, by an entity acceptable to the Owner, and the Contractor shall give timely notice to the Construction Manager and Architect of when and where tests and inspections

are to be made so that the Construction Manager and Architect may be present for such procedures. Such costs, except as provided in Section 13.4.3, shall be at the Owner's expense.

§ 13.4.3 If procedures for testing, inspection, or approval under Sections 13.4.1 and 13.4.2 reveal failure of the portions of the Work to comply with requirements established by the Contract Documents, all costs made necessary by such failure, including those of repeated procedures and compensation for the Construction Manager's and Architect's services and expenses, shall be at the Contractor's expense.

§ 13.4.4 Required certificates of testing, inspection, or approval shall, unless otherwise required by the Contract Documents, be secured by the Contractor and promptly delivered to the Construction Manager for transmittal to the Architect.

§ 13.4.5 If the Construction Manager or Architect is to observe tests, inspections, or approvals required by the Contract Documents, the Construction Manager or Architect will do so promptly and, where practicable, at the normal place of testing.

§ 13.4.6 Tests or inspections conducted pursuant to the Contract Documents shall be made promptly to avoid unreasonable delay in the Work.

§ 13.5 Interest

Payments due and unpaid under the Contract Documents shall bear interest from the date payment is due at the rate the parties agree upon in writing or, in the absence thereof, at the legal rate prevailing from time to time at the place where the Project is located.

§13.6 Equal Opportunity and Non Discrimination

§13.6.1 The Contractor agrees that it, or any person acting on its behalf:

- .1 will not discriminate against any employee or applicant for employment because of race, creed, color, national origin, sex, age, disability, marital status or sexual orientation or gender identity with respect to all employment decisions including, but not limited to recruitment, hiring, compensation, training and apprenticeship, promotion, upgrading, demotion, downgrading, transfer, layoff, termination, and all other terms and conditions of employment;
- .2 will not discriminate in the selection of Subcontractors on the basis of the owner's, partners' or shareholders' race, color, creed, national origin, sex, age, disability, marital status, or sexual orientation; and
- .3 will permit the Owner to have access to all relevant books, records and accounts for the purposes of investigation to ascertain compliance with such requirements.

§13.6.2 The Contractor understands that in the event of its noncompliance with the nondiscrimination clauses of this Contract or with any such requirements, such noncompliance shall constitute a material breach of this Contract. The Contractor further understands that, as provided in Section 220-e of the Labor Law, as amended, there may be deducted from the amount payable to it by the Owner a penalty of fifty dollars (\$50.00) for each person for each calendar day during which said person was discriminated against or intimidated by reason of race, creed, color, disability, sex, or national origin in violation of the provisions of this contract. The Owner may impose any or all of the following sanctions:

- .1 disapproval of the Contractor;
- .2 suspension or termination of this Contract;
- .3 declaring the Contractor in default; or
- .4 adoption and adherence to an employment program.

§13.6.3 The Contractor understands that, as provided in Section 220-e of the Labor Law, as amended, this Contract may be cancelled or terminated by the Owner, and all moneys due or to become due hereunder may be forfeited, for a second or any subsequent violation of the terms and conditions of this Contract with regard to discrimination on the basis of race, creed, color, disability, sex or national origin. The Owner may declare any contractor who has repeatedly failed to comply with Section 220-e of the Labor Law non-responsible.

§13.7 Apprenticeship Training Programs

All contractors and subcontractors on construction contracts exceeding three million dollars (\$3,000,000.00) shall participate in apprenticeship training programs registered by the New York State Department of Labor. Participation in such an apprenticeship program means the contractor or subcontractor: (1) is signatory to a collective bargaining

agreement with a labor organization which sponsors an apprenticeship program registered with the department of labor; (2) individually sponsors an apprenticeship program registered by the department of labor; or (3) is signatory to or otherwise bound by a project labor agreement covering the project which provides for the referral of apprentices. In all cases, such apprenticeship program must be specific to the type and scope of work which is being performed.

§13.8 Minority and Woman Owned Business Enterprises (MWBE) Participation

The Contractor, in addition to any other nondiscrimination provision of the Contract and at no additional cost to the Owner, shall fully comply and cooperate with the Owner in the implementation of the Owner's Minority and Woman Owned Business Enterprises (MWBE) Participation Plan (YJSCB's Diversity Plan) included in the Contract Documents. These requirements include contracting opportunities for certified minority and women-owned business enterprises ("MWBEs"). Contractor's demonstration of "good faith efforts" shall be a part of these requirements. These provisions shall be deemed supplementary to, and not in lieu of the nondiscrimination provisions required by the Owner or other applicable federal, state or local laws.

ARTICLE 14 TERMINATION OR SUSPENSION OF THE CONTRACT

§ 14.1 Termination by the Contractor

§ 14.1.1 The Contractor may terminate the Contract if the Work is stopped for a period of 30 consecutive days through no act or fault of the Contractor, a Subcontractor, a Sub-subcontractor, their agents or employees, or any other persons or entities performing portions of the Work, for any of the following reasons:

- .1 Issuance of an order of a court or other public authority having jurisdiction that requires all Work to be stopped;
- .2 An act of government, such as a declaration of national emergency, that requires all Work to be stopped;
- ~~.3 Because the Construction Manager has not certified or the Architect has not issued a Certificate for Payment and has not notified the Contractor of the reason for withholding certification as provided in Section 9.4, or because the Owner has not made payment on a Certificate for Payment within the time stated in the Contract Documents; or~~
- ~~.4 The Owner has failed to furnish to the Contractor reasonable evidence as required by Section 2.2.~~

~~**§ 14.1.2** The Contractor may terminate the Contract if, through no act or fault of the Contractor, a Subcontractor, a Sub-subcontractor, their agents or employees, or any other persons or entities performing portions of the Work, repeated suspensions, delays, or interruptions of the entire Work by the Owner as described in Section 14.3, constitute in the aggregate more than 100 percent of the total number of days scheduled for completion, or 120 days in any 365-day period, whichever is less.~~

§ 14.1.3 If one of the reasons described in Section 14.1.1 ~~or 14.1.2~~ exists, the Contractor may, upon seven days' notice to the Owner, Construction Manager and Architect, terminate the Contract and recover from the Owner payment for Work executed, as well as reasonable overhead and profit on Work not executed, and costs incurred by reason of such termination.

~~**§ 14.1.4** If the Work is stopped for a period of 60 consecutive days through no act or fault of the Contractor, a Subcontractor, a Sub-subcontractor, or their agents or employees, or any other persons performing portions of the Work because the Owner has repeatedly failed to fulfill the Owner's obligations under the Contract Documents with respect to matters important to the progress of the Work, the Contractor may, upon seven additional days' notice to the Owner, Construction Manager and Architect, terminate the Contract and recover from the Owner as provided in Section 14.1.3.~~

§ 14.2 Termination by the Owner for Cause

§ 14.2.1 The Owner may terminate the Contract if the Contractor

- .1 repeatedly refuses or fails to supply enough properly skilled workers or proper materials;
- .2 fails to make payment to Subcontractors or suppliers in accordance with the respective agreements between the Contractor and the Subcontractors or suppliers;
- .3 repeatedly disregards applicable laws, statutes, ordinances, codes, rules and regulations, or lawful orders of a public authority; or
- .4 otherwise is guilty of substantial breach of a provision of the Contract Documents.

§ 14.2.2 When any of the reasons described in Section 14.2.1 exist, after consultation with the Construction Manager, and upon certification by the Architect that sufficient cause exists to justify such action, the Owner may, without

prejudice to any other rights or remedies of the Owner and after giving the Contractor and the Contractor's surety, if any, seven days' notice, terminate employment of the Contractor and may, subject to any prior rights of the surety:

- .1 Exclude the Contractor from the site and take possession of all materials, equipment, tools, and construction equipment and machinery thereon owned by the Contractor;
- .2 Accept assignment of subcontracts pursuant to Section 5.4; and
- .3 Finish the Work by whatever reasonable method the Owner may deem expedient. Upon written request of the Contractor, the Owner shall furnish to the Contractor a detailed accounting of the costs incurred by the Owner in finishing the Work.

§ 14.2.3 When the Owner terminates the Contract for one of the reasons stated in Section 14.2.1, the Contractor shall not be entitled to receive further payment until the Work is finished.

§ 14.2.4 If the unpaid balance of the Contract Sum exceeds costs of finishing the Work, including compensation for the Construction Manager's and Architect's services and expenses made necessary thereby, and other damages incurred by the Owner and not expressly waived, such excess shall be paid to the Contractor. If such costs and damages exceed the unpaid balance, the Contractor shall pay the difference to the Owner. The amount to be paid to the Contractor or Owner, as the case may be, shall, upon application, be certified by the Initial Decision Maker after consultation with the Construction Manager, and this obligation for payment shall survive termination of the Contract.

§ 14.3 Suspension by the Owner for Convenience

§ 14.3.1 The Owner may, without cause, order the Contractor in writing to suspend, delay or interrupt the Work, in whole or in part for such period of time as the Owner may determine.

§ 14.3.2 The Contract Sum and the Contract Time shall be adjusted for increases in the cost and time caused by suspension, delay, or interruption under Section 14.3.1. Adjustment of the Contract Sum shall include profit. No adjustment shall be made to the extent:

- .1 that performance is, was, or would have been, so suspended, delayed, or interrupted, by another cause for which the Contractor is responsible; or
- .2 that an equitable adjustment is made or denied under another provision of this Contract.

§ 14.4 Termination by the Owner for Convenience

§ 14.4.1 The Owner may, at any time, terminate the Contract for the Owner's convenience and without cause.

§ 14.4.2 Upon receipt of notice from the Owner of such termination for the Owner's convenience, the Contractor shall

- .1 cease operations as directed by the Owner in the notice;
- .2 take actions necessary, or that the Owner may direct, for the protection and preservation of the Work; and
- .3 except for Work directed to be performed prior to the effective date of termination stated in the notice, terminate all existing subcontracts and purchase orders and enter into no further subcontracts and purchase orders.

§ 14.4.3 In case of such termination for the Owner's convenience, the Owner shall pay the Contractor for Work properly executed; costs incurred by reason of the termination, including costs attributable to termination of Subcontracts; and the termination fee, if any, set forth in the Agreement.

ARTICLE 15 CLAIMS AND DISPUTES

§ 15.1 Claims

§ 15.1.1 **Definition.** A Claim is a demand or assertion by one of the parties seeking, as a matter of right, payment of money, a change in the Contract Time, or other relief with respect to the terms of the Contract. The term "Claim" also includes other disputes and matters in question between the Owner and Contractor arising out of or relating to the Contract. The responsibility to substantiate Claims shall rest with the party making the Claim. This Section 15.1.1 does not require the Owner to file a Claim in order to impose liquidated damages in accordance with the Contract Documents.

§ 15.1.2 Time Limits on Claims

The Owner and Contractor shall commence all Claims and causes of action against the other and arising out of or related to the Contract, whether in contract, tort, breach of warranty or otherwise, in accordance with the requirements of the binding dispute resolution method selected in the Agreement and within the period specified by applicable law,

but in any case not more than 10 years after the date of Substantial Completion of the Work. The Owner and Contractor waive all Claims and causes of action not commenced in accordance with this Section 15.1.2.

§ 15.1.3 Notice of Claims

§ 15.1.3.1 Claims by either the Owner or Contractor, where the condition giving rise to the Claim is first discovered prior to expiration of the period for correction of the Work set forth in Section 12.2.2, shall be initiated by notice to the other party and to the Initial Decision Maker with a copy sent to the Construction Manager and Architect, if the Architect is not serving as the Initial Decision Maker. Claims by either party under this Section 15.1.3.1 shall be initiated within 21 days after occurrence of the event giving rise to such Claim or within 21 days after the claimant first recognizes the condition giving rise to the Claim, whichever is later.

§ 15.1.3.2 Claims by either the Owner or Contractor, where the condition giving rise to the Claim is first discovered after expiration of the period for correction of the Work set forth in Section 12.2.2, shall be initiated by notice to the other party. In such event, no decision by the Initial Decision Maker is required.

§ 15.1.4 Continuing Contract Performance

§ 15.1.4.1 Pending final resolution of a Claim, except as otherwise agreed in writing or as provided in Section 9.7 and Article 14, the Contractor shall proceed diligently with performance of the Contract and the Owner shall continue to make payments in accordance with the Contract Documents.

§ 15.1.4.2 The Contract Sum and Contract Time shall be adjusted in accordance with the Initial Decision Maker's decision, subject to the right of either party to proceed in accordance with this Article 15. The Architect will issue Certificates for Payment in accordance with the decision of the Initial Decision Maker.

§ 15.1.5 Claims for Additional Cost. If the Contractor wishes to make a Claim for an increase in the Contract Sum, notice as provided in Section 15.1.3 shall be given before proceeding to execute the portion of the Work that is the subject of the Claim. Prior notice is not required for Claims relating to an emergency endangering life or property arising under Section 10.4.

§ 15.1.6 Claims for Additional Time

§ 15.1.6.1 If the Contractor wishes to make a Claim for an increase in the Contract Time, notice as provided in Section 15.1.3 shall be given. The Contractor's Claim shall include an estimate of cost and of probable effect of delay on progress of the Work. In the case of a continuing delay only one Claim is necessary.

§ 15.1.6.2 If adverse weather conditions are the basis for a Claim for additional time, such Claim shall be documented by data substantiating that weather conditions were abnormal for the period of time, could not have been reasonably anticipated and had an adverse effect on the scheduled construction.

§ 15.1.7 Waiver of Claims for Consequential Damages. The Contractor and Owner waive Claims against each other for consequential damages arising out of or relating to this Contract. This mutual waiver includes

- .1 damages incurred by the Owner for rental expenses, for losses of use, income, profit, financing, business and reputation, and for loss of management or employee productivity or of the services of such persons; and
- .2 damages incurred by the Contractor for principal office expenses including the compensation of personnel stationed there, for losses of financing, business and reputation, and for loss of profit except anticipated profit arising directly from the Work.

This mutual waiver is applicable, without limitation, to all consequential damages due to either party's termination in accordance with Article 14. Nothing contained in this Section 15.1.7 shall be deemed to preclude assessment of liquidated damages, when applicable, in accordance with the requirements of the Contract Documents.

§ 15.2 Initial Decision

§ 15.2.1 Claims, excluding those where the condition giving rise to the Claim is first discovered after expiration of the period for correction of the Work set forth in Section 12.2.2 or arising under Sections 10.3, 10.4, and 11.5, shall be referred to the Initial Decision Maker for initial decision. The Architect will serve as the Initial Decision Maker, unless otherwise indicated in the Agreement. Except for those Claims excluded by this Section 15.2.1, an initial decision shall be required as a condition precedent to mediation of any Claim. If an initial decision has not been rendered within 30 days after the Claim has been referred to the Initial Decision Maker, the party asserting the Claim may demand

mediation and binding dispute resolution without a decision having been rendered. Unless the Initial Decision Maker and all affected parties agree, the Initial Decision Maker will not decide disputes between the Contractor and persons or entities other than the Owner.

§ 15.2.2 The Initial Decision Maker will review Claims and within ten days of the receipt of a Claim take one or more of the following actions: (1) request additional supporting data from the claimant or a response with supporting data from the other party, (2) reject the Claim in whole or in part, (3) approve the Claim, (4) suggest a compromise, or (5) advise the parties that the Initial Decision Maker is unable to resolve the Claim if the Initial Decision Maker lacks sufficient information to evaluate the merits of the Claim or if the Initial Decision Maker concludes that, in the Initial Decision Maker's sole discretion, it would be inappropriate for the Initial Decision Maker to resolve the Claim.

§ 15.2.3 In evaluating Claims, the Initial Decision Maker may, but shall not be obligated to, consult with or seek information from either party or from persons with special knowledge or expertise who may assist the Initial Decision Maker in rendering a decision. The Initial Decision Maker may request the Owner to authorize retention of such persons at the Owner's expense.

§ 15.2.4 If the Initial Decision Maker requests a party to provide a response to a Claim or to furnish additional supporting data, such party shall respond, within ten days after receipt of the request, and shall either (1) provide a response on the requested supporting data, (2) advise the Initial Decision Maker when the response or supporting data will be furnished, or (3) advise the Initial Decision Maker that no supporting data will be furnished. Upon receipt of the response or supporting data, if any, the Initial Decision Maker will either reject or approve the Claim in whole or in part.

§ 15.2.5 The Initial Decision Maker will render an initial decision approving or rejecting the Claim, or indicating that the Initial Decision Maker is unable to resolve the Claim. This initial decision shall (1) be in writing; (2) state the reasons therefor; and (3) notify the parties, the Construction Manager, and the Architect, if the Architect is not serving as the Initial Decision Maker, of any change in the Contract Sum or Contract Time or both. The initial decision shall be final and binding on the parties but subject to mediation and, if the parties fail to resolve their dispute through mediation, to binding dispute resolution.

§ 15.2.6 Either party may file for mediation of an initial decision at any time, subject to the terms of Section 15.2.6.1.

§ 15.2.6.1 Either party may, within 30 days from the date of receipt of an initial decision, demand in writing that the other party file for mediation. If such a demand is made and the party receiving the demand fails to file for mediation within 30 days of receipt thereof, then both parties waive their rights to mediate or pursue binding dispute resolution proceedings with respect to the initial decision.

§ 15.2.7 In the event of a Claim against the Contractor, the Owner may, but is not obligated to, notify the surety, if any, of the nature and amount of the Claim. If the Claim relates to a possibility of a Contractor's default, the Owner may, but is not obligated to, notify the surety and request the surety's assistance in resolving the controversy.

§ 15.2.8 If a Claim relates to or is the subject of a mechanic's lien, the party asserting such Claim may proceed in accordance with applicable law to comply with the lien notice or filing deadlines.

§ 15.3 Mediation

§ 15.3.1 Claims, disputes, or other matters in controversy arising out of or related to the Contract, except those waived as provided for in Sections 9.10.4, 9.10.5, and 15.1.7, shall be subject to mediation as a condition precedent to binding dispute resolution.

§ 15.3.2 The parties shall endeavor to resolve their Claims by mediation which, unless the parties mutually agree otherwise, shall be administered by the American Arbitration Association in accordance with its Construction Industry Mediation Procedures in effect on the date of the Agreement. A request for mediation shall be made in writing, delivered to the other party to the Contract, and filed with the person or entity administering the mediation. The request may be made concurrently with the filing of binding dispute resolution proceedings but, in such event, mediation shall proceed in advance of binding dispute resolution proceedings, which shall be stayed pending mediation for a period of 60 days from the date of filing, unless stayed for a longer period by agreement of the parties or court order. If an arbitration is stayed pursuant to this Section 15.3.2, the parties may nonetheless proceed to the selection of the arbitrator(s) and agree upon a schedule for later proceedings.

§ 15.3.3 Either party may, within 30 days from the date that mediation has been concluded without resolution of the dispute or 60 days after mediation has been demanded without resolution of the dispute, demand in writing that the other party file for binding dispute resolution. If such a demand is made and the party receiving the demand fails to file for binding dispute resolution within 60 days after receipt thereof, then both parties waive their rights to binding dispute resolution proceedings with respect to the initial decision.

§ 15.3.4 The parties shall share the mediator's fee and any filing fees equally. The mediation shall be held in the place where the Project is located, unless another location is mutually agreed upon. Agreements reached in mediation shall be enforceable as settlement agreements in any court having jurisdiction thereof.

§ 15.4 Arbitration

§ 15.4.1 If the parties have selected arbitration as the method for binding dispute resolution in the Agreement, any Claim subject to, but not resolved by, mediation shall be subject to arbitration which, unless the parties mutually agree otherwise, shall be administered by the American Arbitration Association in accordance with its Construction Industry Arbitration Rules in effect on the date of the Agreement. The Arbitration shall be conducted in the place where the Project is located, unless another location is mutually agreed upon. A demand for arbitration shall be made in writing, delivered to the other party to the Contract, and filed with the person or entity administering the arbitration. The party filing a notice of demand for arbitration must assert in the demand all Claims then known to that party on which arbitration is permitted to be demanded.

§ 15.4.1.1 A demand for arbitration shall be made no earlier than concurrently with the filing of a request for mediation, but in no event shall it be made after the date when the institution of legal or equitable proceedings based on the Claim would be barred by the applicable statute of limitations. For statute of limitations purposes, receipt of a written demand for arbitration by the person or entity administering the arbitration shall constitute the institution of legal or equitable proceedings based on the Claim.

§ 15.4.2 The award rendered by the arbitrator or arbitrators shall be final, and judgment may be entered upon it in accordance with applicable law in any court having jurisdiction thereof.

§ 15.4.3 The foregoing agreement to arbitrate and other agreements to arbitrate with an additional person or entity duly consented to by parties to the Agreement, shall be specifically enforceable under applicable law in any court having jurisdiction thereof.

§ 15.4.4 Consolidation or Joinder

§ 15.4.4.1 Subject to the rules of the American Arbitration Association or other applicable arbitration rules, either party may consolidate an arbitration conducted under this Agreement with any other arbitration to which it is a party provided that (1) the arbitration agreement governing the other arbitration permits consolidation, (2) the arbitrations to be consolidated substantially involve common questions of law or fact, and (3) the arbitrations employ materially similar procedural rules and methods for selecting arbitrator(s).

§ 15.4.4.2 Subject to the rules of the American Arbitration Association or other applicable arbitration rules, either party may include by joinder persons or entities substantially involved in a common question of law or fact whose presence is required if complete relief is to be accorded in arbitration, provided that the party sought to be joined consents in writing to such joinder. Consent to arbitration involving an additional person or entity shall not constitute consent to arbitration of any claim, dispute or other matter in question not described in the written consent.

§ 15.4.4.3 The Owner and Contractor grant to any person or entity made a party to an arbitration conducted under this Section 15.4, whether by joinder or consolidation, the same rights of joinder and consolidation as those of the Owner and Contractor under this Agreement.

The following additions, substitutions, or clarifications are extracted from the (5) Bid Addenda issued with this project during bidding. This insert is intended to summarize addendum information relevant to this specification section. See Bid Addenda issued by the City of Yonkers for complete contract document changes.

Bid Addendum No. 2:

Page 1, item (xi) "Pollution Liability" – Add the note "from the General Construction Contractor ONLY" next to "REQUIRED". Only the GC will be required to carry this insurance.

Page 5, Item G.1, revise the first sentence to read: "The General Contractor at his own cost and expense shall provide and maintain Contractors Pollution Liability coverage of \$5,000,000 per Occurrence and \$5,000,000 aggregate, such aggregate must be applicable on a Per Project Basis."

OWNER'S INSURANCE REQUIREMENTS

Where indicated by an (x), Insurance in the amounts specified below are required under this Contract.

(x) Worker's Compensation Statutory
(x) Employer's Liability \$1,000,000 each Accident

(x) Commercial General Liability – Combined Single Limit-Bodily Injury and Property Damage:
\$1,000,000 per occurrence
\$1,000,000 Products/Completed Operations Aggregate
\$2,000,000 General Aggregate
\$25,000 Maximum Deductible

(x) Automobile Liability – Combined Single Limit – Bodily Injury and Property Damage:
\$1,000,000 per person each occurrence for Bodily Injury
\$100,000 per occurrence Property Damage
The following coverage must be provided:
(x) Comprehensive (x) Owned (x) Hired (x) Non-Owned

(xi) Pollution Liability: Required Not Required
\$5,000,000 per person each occurrence
\$5,000,000 aggregate

In addition, if indicated by an (x), the following hazards must be covered:

Excess Insurance _____
 Other _____

(x) Additional Named Insured: **SEE ATTACHED**

CONTRACTORS INSURANCE REQUIREMENTS – YJSCB

GENERAL PROVISIONS

Prior to the commencement of the work to be performed by the Contractor hereunder, the Contractor shall file with Secretary YJSCB, Certificates of Insurance evidencing compliance with all requirements contained in this Contract. Such Certificates shall be of form and substance acceptable to the YJSCB.

Acceptance and/or approval by the YJSCB, its agents or employees, does not and shall not be construed to relieve Contractor of any obligations, responsibilities or liabilities under the Contract.

All insurance required by the Contract shall be obtained at the sole cost and expense of the Contractor, shall be maintained by the insurance carriers licensed and admitted to do business in New York State, and acceptable to the YJSCB; shall be primary and non-contributing to any insurance or self insurance maintained by the YJSCB; shall be endorsed to provide written notice be given to the YJSCB, at least thirty (30) days prior to the cancellation, non-renewal, or material alteration of such policies, which notice, evidence by return of receipt of United States Certified Mail and shall name the Contractor and identify the contract number, shall be sent to the Secretary YJSCB and shall name the YJSCB, its officers, agents and employees as additional insureds thereunder (General Liability Additional Insured Endorsement shall be on form number CG 20 10 11 85.)

The Contractor shall be solely responsible for the payment of all deductibles and self-insured retentions to which such policies are subject. Deductibles and self-insured retentions must be approved by the YJSCB. Such approval shall not be unreasonably withheld. The YJSCB reserves the right to withhold portion of payment until the deductible is satisfied.

Each insurance carrier must be rated at least "A" in the most recently published Best's Insurance Report. If, during the term of the policy, a carrier's rating falls below "A" the insurance must be replaced no later than the renewal date of the policy with an insurer acceptable to the YJSCB and rated at least "A" in the most recently published Best's Insurance Report.

The Contractor shall cause all insurance to be in full force and effect as of the commencement date of this Contract and to remain in full force and effect throughout the term of this Contract and as further required by this Contract. The Contractor shall not take any action, or omit to take any action that would suspend or invalidate any of the required coverages during the period of time such coverages are required to be in effect.

Not less than thirty (30) days prior to the expiration date or renewal date, the Contractor shall supply the YJSCB updated replacement Certificates of Insurance and amendatory endorsements.

If at any time, a non-admitted carrier that has to be used becomes financially unsatisfactory to the YJSCB, immediate replacement will be required. Failure to do so may void the contract.

If at any time any of the policies required herein shall be or become unsatisfactory to the YJSCB, as to form or substance, or if a company issuing any such policy shall be or become unsatisfactory to the YJSCB, the Contractor shall upon notice to that effect from the YJSCB, promptly obtain a new policy, submit the same to the Office of Corporation Counsel of the City of Yonkers for approval and submit a certificate thereof. Upon failure of the Contractor to furnish, deliver and maintain such insurance, the Contract, at the election of the YJSCB, may be declared suspended, discontinued or terminated. Failure of the Contractor to take out, maintain, or the taking out or maintenance of any required insurance, shall not relieve the Contractor from any liability under the Contract, nor shall the insurance requirements be construed to conflict with or otherwise limit the contractual obligations of the Contractor concerning indemnification. All property losses shall be made payable to and adjusted with the YJSCB.

In the event that claims, for which the YJSCB may be liable, in excess of the insured amounts provided herein are filed by reason of any operations under the Contract, the amount of excess of such claims or any portion thereof, may be withheld from payment due or to become due the Contractor until such time as the Contractor shall furnish such additional security covering such claims in form satisfactory to the YJSCB.

A. WORKER'S COMPENSATION INSURANCE

Workers' Compensation. Certificate form C-105.2 (9/07) or State Fund Insurance Company form U-26.3 is required for proof of compliance with the New York State Workers' Compensation Law. State Workers' Compensation Board form DB-120.1 is required for proof of compliance with the New York State Disability Benefits Law. Location of operation shall be "All locations in Yonkers, New York."

Where an applicant claims to not be required to carry either a Workers' Compensation Policy or Disability Benefits Policy, or both, the employer must complete NYS form CE-200, available to download at: www.wcb.state.ny.us (click on Employers/Businesses, then Business Permits/Licenses/Contracts to see instruction manual).

If the employer is self-insured for Worker's Compensation, he/she should present a certificate from the New York State Worker's Compensation Board evidencing that fact (Either SI-12, Certificate of Workers' Compensation Self-Insurance, or GSI-105.2, Certificate of Participation in Workers' Compensation Group Self-Insurance).

B. EMPLOYER'S LIABILITY INSURANCE

Before performing any work on the Contract, the Contractor shall procure Employer's Liability Insurance affording compensation for all employees providing labor or services for whom worker's compensation coverage is not a statutory requirement. Two (2) certificates of such insurance shall be furnished to the Schools Facilities Executive Director.

C. COMMERCIAL GENERAL LIABILITY

Before commencing work at the site, the Contractor shall procure a commercial general liability insurance policy (issued by a New York admitted carrier) with a limit of not less than \$1,000,000 each occurrence. This insurance policy must be maintained during the life of the contract and shall protect the YJSCB, the Contractor and its subcontractors performing work at the site from claims for property damage and/or bodily injury which may arise from operations under this contract, whether such operations are performed by it or anyone directly or indirectly employed by it.

Two (2) certificates of insurance shall be furnished to the Engineer in a manner acceptable to the YJSCB, together with copies of all endorsements as required by this Contract. Such liability shall be written on the Insurance Service Office's (ISO) occurrence form CG 0001 or a substitute form providing equivalent coverages and shall cover liability arising from:

- (1) Premises – Operations
- (2) Independent Contractors and Subcontractors
- (3) Products and Completed Operations
- (4) Broad Form Property Damages
- (5) Personal and Advertising Injury

Additional coverages and limits may be required based upon the particular services contracted.

- (i) All contracts involving explosives, demolition and underground work shall provide the above coverage with elimination of the XCU exclusion.
- (ii) Products and Completed Operations coverage shall include a provision that coverage will extend for a period of at least twelve (12) months from the date of final completion and acceptance by the owner of all Contractors work.

- (iii) Products and Completed Operations coverage shall include a provision that coverage will extend for a period of at least twelve (12) months from the date of final completion and acceptance by the owner for all Contractor's work.

D. Automobile Liability Insurance

Contractor shall procure and maintain automobile liability insurance policy (issued by a New York admitted carrier) with a limit a minimum limit of liability per occurrence of \$1,000,000 for bodily injury and a minimum limit of \$100,000 per occurrence for property damage or a combined single limit of \$1,000,000 unless otherwise indicated in the contract specifications. This insurance shall include for bodily injury and property damage the following coverages:

- (i) Owned automobiles.
- (ii) Hired automobiles.
- (iii) Non-owned automobiles.

E. GENERAL LIABILITY AND AUTOMOBILE ENDORSEMENTS AND EXCLUSIONS

1. The following endorsements are required to be made on all policies:
 - (a) Notice shall be addressed to the Schools Facilities Management Executive Director, Yonkers Public Schools, One Larkin Plaza, Yonkers, New York, 10701.
 - (b) Notice of Cancellation of Policy. The policy shall not be cancelled, terminated, modified, or changed by the Company unless thirty (30) days prior written notice is sent to the Schools Facilities Management Executive Director.
 - (c) Insurers shall have no right of recovery or subrogation against the YJSCB (including its agents and agencies as aforesaid), it being the intention of the parties that the insurance policies so effected shall protect both parties and may be primary coverage for any and all losses covered by the above described insurance.
2. The policy shall contain no exclusions or endorsements, which are not acceptable to the YJSCB and shall be of a form and by an insurance company acceptable to the YJSCB.

F. CONSTRUCTION INSURANCE

1. For the construction, renovation or repair of bridges, viaducts or similar structures, the Contractor at his own cost and expense shall provide and maintain a "Bridge Builder's Risk Form, All Risk Insurance Contract," with flat premium endorsement, until the construction contract is accepted by the YJSCB. The coverage shall be written for 100% of the completed value, covering the YJSCB as the insured, with a deductible of not more than \$100, as recommended by the New York State Department of Insurance. The Contractor shall provide the original and duplicate policy to the YJSCB (unless the YJSCB shall accept, in lieu thereof, all contained endorsements including all applicable provisions and coverages).
2. Commercial Property Insurance covering at a minimum, the perils insured under the ISO Special Causes of Loss Form (CP 10 30), or a substitute form providing equivalent coverages, for loss or damage to any owned, borrowed, leased or rented capital equipment, tools, including tools of their agents or employees, staging towers and forms, and property of the YJSCB held in their care, custody and/or control.
3. During the performance of the Construction Work, Restoration or Alteration, builder's risk completed value form covering the perils insured under the ISO special cases of loss form, including collapse, water damage, and transit and theft of building materials, with the deductible reasonable approved by the Senate, in non reporting form, covering the total value of work performed and equipment, supplies and materials at any off-site storage location used with respect to the Project.

4. If the work involves abatement, removal, repair, replacement, enclosure, encapsulation and/or disposal of any hazardous material or substance, the Contractor shall maintain in full force and effect throughout the term hereof, pollution legal liability insurance with the limits of not less than \$1,000,000, providing coverage for bodily injury and property damage, including loss of use of damage property or of property that has not been physically injured. Such policy shall provide coverage for actual, alleged or threatened emission, discharge, dispersal, seepage, release or escape of pollutants, including any loss, cost or expense incurred as a result of any cleanup of pollutants or in the investigation, settlement or defense of any claim, suit, or proceedings against the YJSCB arising from Contractors work.
 - a. If the coverage is written on a claims-made policy, the Contractor warrants that any applicable retroactive date precedes the effective date of this Contract; and that continuous coverage be maintained, or an extended discovery period exercised, for a period of not less than 2 years from the time of work under this contract is completed.
 - b. If the Contract includes disposal of materials from the job site, the Contractor must furnish to the YJSCB, evidence of pollution legal liability insurance in the amount of \$1,000,000 maintained by the disposal site operator for losses arising from the disposal site accepting waste under this Contract.
5. The Contractor shall maintain, or if subcontracting professional services, shall certify that Subcontractor maintain, errors and omissions liability insurance with a limit of not less than \$1,000,000 per loss.
 - a. Such insurance shall apply to professional errors, acts, or omissions arising out of the scope of services covered by this Contract and may not exclude bodily injury, property damage, pollution or asbestos related claims, testing, monitoring, measuring or laboratory analyses.
 - b. If coverage is written on a claims-made policy, the Contractor warrants that any applicable retroactive date precedes the effective date of this Contract, and that continuous coverage will be maintained, or an extended discovery period exercised, for a period of not less than two years from the time work under this Contract is completed.
6. If autos are to be used for transporting hazardous materials, the Contractor shall provide pollution liability broadened coverage for covered autos (endorsement CA 99 48) as well as proof of MCS 90.

The Contractor shall require that any subcontractor hired, carry insurance with the same limits and provisions provided herein.

G. POLLUTION INSURANCE

1. The Contractor at his own cost and expense shall provide and maintain Contractors Pollution Liability coverage of \$10,000,000 per Occurrence and \$10,000,000 aggregate, such aggregate must be applicable on a Per Project Basis. A Contractors Pollution or Environmental Liability Umbrella/Excess policy may be utilized to satisfy these limits.
2. Contractors Pollution Liability coverage should be written on an Occurrence Basis. Occurrence Coverage must be maintained for the duration of the project and for a period of three years after the completion of the contract. If written on a Claims Made Basis the policy must have a Retroactive date which is prior to the date of the Contract and it must have a claims reporting period of no less than three years.
3. Project Owner and all other parties required by the Contract shall be included as Additional Insureds on the policy on a primary and non-contributory basis for on-going and completed operations.
4. Coverage shall provide pollution liability coverage of no less than \$1,000,000 for: Transportation Pollution Liability Coverage Non-Owned Disposal Sites Contractors Pollution coverage

H. OTHER PROVISIONS

1. The Contractor is required to obtain and to maintain bonds and insurance outlined herein.
2. The bonds and insurance required for this contract must be on forms acceptable to the YJSCB and offered by insurers and sureties acceptable to the YJSCB. The insurance and bonds for all New York contractors must be issued by New York authorized carriers and must comply with all requirements of New York Law and Regulation, and in the case of bonds, be in the exact form as provided in the bid and contract documents.
3. The YJSCB, may at its discretion, and if approved by the City of Yonkers Law Department, accept letters of credit or custodial accounts in lieu of bonds and insurance requirements.
4. If at any time any of the foregoing bonds and policies shall be or become unsatisfactory to the YJSCB, as to form or substance, or if a company issuing any such policy shall be or become unsatisfactory to the YJSCB, the Contractor shall upon notice to that effect from the YJSCB, promptly obtain a new policy, and submit the same to the School Facilities Management Executive Director. Upon failure of the Contractor to furnish, deliver and maintain such insurance as above provided, this contract, at the election of the YJSCB may be forthwith declared suspended, discontinued or terminated. Failure of the Contractor to take out and/or maintain or the taking out and/or maintenance of any required insurance, shall not relieve the Contractor from any liability be construed to conflict with or otherwise limit the obligations of the Contractor concerning indemnification.
5. The Contractor shall be solely responsible for payment of all premiums for bonds and insurance contributing to satisfaction of the requirements herein, and shall be solely responsible for the payment of all deductibles to which such policies are subject, whether or not YJSCB is named as additional insured.
6. The YJSCB reserves the right to increase or decrease the required insurance during the Contract.

CERTIFICATE HOLDER

Yonkers Joint Schools Construction Board
40 South Broadway
Yonkers, NY 10701

LIST OF PARTIES TO BE NAMED AS ADDITIONAL INSURED

The City of Yonkers, its officers, elected officials, agents and employees
40 South Broadway
Yonkers, NY 10701

Yonkers City School District, acting by and through the Trustees of the Yonkers Board of Education
1 Larkin Center
Yonkers, NY 10701

The Yonkers Industrial Development Agency (including all of respective officers, employees, elected officials and agents, of the foregoing)
470 Nepperhan Avenue, No. 200
Yonkers, NY 10701

ARCHITECT

KG+D Architects (and the KG+D's consultants and sub-consultants)
285 Main Street
Mount Kisco, NY 10549

PROGRAM MANAGER / CONSTRUCTION MANAGER

Savin Engineers, P.C. (and Savin Engineers, P.C. consultants and sub-consultants)
3 Campus Drive
Pleasantville, NY 10570

Asbestos Designer & Air Monitor

Eisenbach & Ruhnke Engineering, P.C.
291 Genesee Street
Utica, NY 13501

MEP ENGINEER

Barile Gallagher & Associates Consulting Engineers, P.C.
39 Marble Avenue
Pleasantville, NY 10570

SITE/CIVIL ENGINEER & LANDSCAPE

Insite Engineering, Surveying & Landscape Architecture, P.C.
3 Garrett Place
Carmel, NY 10512

STRUCTURAL ENGINEERS

The DiSalvo Engineering Group
83 Wooster Heights Rd, Suite 200
Danbury, CT 06810

INDEPENDENT COMPLIANCE OFFICER (ICO)

Landon & Rian Enterprises Inc.
1411 Chili Ave.
Rochester, NY 14624

BANK

Manufacturers and Traders Trust Company, as Bond Trustee
1 M&T Plaza, 3rd Floor Buffalo, NY
14203

ADJACENT PROPERTY OWNERS

Odeh Abbassi Fared
Abbassi Mathher Abbassi

12 Radford Street
Yonkers, New York 10705

10 Radford Realty LLC
P.O. Box 294
Yonkers, New York 10710

115 McLean Avenue LLC
P.O. Box 116
Eastchester, New York 10709

Arnold Perez and Benita Perez
520 Van Cortlandt Park Avenue Yonkers,
New York 10705

Joel D. Quiambao and Rosemarie Quiambao
28 Radford Street Yonkers, New York
10705

Teddoccia Pingol
30 Radford Street Yonkers, New York
10705

Walter G Enamorado
477 Van Cortlandt Park Avenue Yonkers,
New York 10705

Archdiocese of New York

1011 1st Avenue New York, NY
10022

Must state:

The Archdiocese of New York, His Eminence Timothy Cardinal Dolan, The Parish of St Peter and St Denis, Catholic Mutual Group, All Parishes, Schools or Properties within the Archdiocese and All Organizations and their properties rented, owned or operated throughout the Archdiocese of New York are named as additional insured. Umbrella/Excess Liability Coverage is primary & non-contributory insurance to any other insurance available to the additional insured with respects to claims arising hereunder.

*****Note: The YJSCB reserves the right to require additional named insureds.**

DRAFT AIA® Document A312™ - 2010

Performance Bond

CONTRACTOR:

(Name, legal status and address)

« »
« »

SURETY:

(Name, legal status and principal place of business)

« »
« »

OWNER:

(Name, legal status and address)

«Yonkers Joint Schools Construction Board»
«City Hall
40 South Broadway
Yonkers, NY 10701»

CONSTRUCTION CONTRACT

Date: « »

Amount: \$ «0.00»

Description:

(Name and location)

«Community School 35»
«121 McLean Avenue,
Yonkers, NY 10705»

BOND

Date:

(Not earlier than Construction Contract Date)

« »

Amount: \$ « »

Modifications to this Bond: None See Section 16

CONTRACTOR AS PRINCIPAL

Company: (Corporate Seal)

Signature:

Name and « »

Title:

(Any additional signatures appear on the last page of this Performance Bond.)

SURETY

Company: (Corporate Seal)

Signature:

Name and « »

Title:

(FOR INFORMATION ONLY — Name, address and telephone)

AGENT or BROKER:

« »
« »
« »

OWNER'S REPRESENTATIVE:

(Architect, Engineer or other party:)

«Mayor Mike Spano »

« »
« »
« »
« »
« »

ADDITIONS AND DELETIONS: The author of this document has added information needed for its completion. The author may also have revised the text of the original AIA standard form. An *Additions and Deletions Report* that notes added information as well as revisions to the standard form text is available from the author and should be reviewed.

This document has important legal consequences. Consultation with an attorney is encouraged with respect to its completion or modification.

Any singular reference to Contractor, Surety, Owner or other party shall be considered plural where applicable.

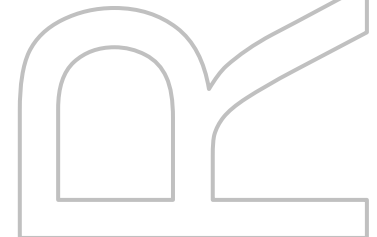

ELECTRONIC COPYING of any portion of this AIA® Document to another electronic file is prohibited and constitutes a violation of copyright laws as set forth in the footer of this document.

§ 1 The Contractor and Surety, jointly and severally, bind themselves, their heirs, executors, administrators, successors and assigns to the Owner for the performance of the Construction Contract, which is incorporated herein by reference.

§ 2 If the Contractor performs the Construction Contract, the Surety and the Contractor shall have no obligation under this Bond, except when applicable to participate in a conference as provided in Section 3.

§ 3 If there is no Owner Default under the Construction Contract, the Surety's obligation under this Bond shall arise after

- .1 the Owner first provides notice to the Contractor and the Surety that the Owner is considering declaring a Contractor Default. Such notice shall indicate whether the Owner is requesting a conference among the Owner, Contractor and Surety to discuss the Contractor's performance. If the Owner does not request a conference, the Surety may, within five (5) business days after receipt of the Owner's notice, request such a conference. If the Surety timely requests a conference, the Owner shall attend. Unless the Owner agrees otherwise, any conference requested under this Section 3.1 shall be held within ten (10) business days of the Surety's receipt of the Owner's notice. If the Owner, the Contractor and the Surety agree, the Contractor shall be allowed a reasonable time to perform the Construction Contract, but such an agreement shall not waive the Owner's right, if any, subsequently to declare a Contractor Default;
- .2 the Owner declares a Contractor Default, terminates the Construction Contract and notifies the Surety; and
- .3 the Owner has agreed to pay the Balance of the Contract Price in accordance with the terms of the Construction Contract to the Surety or to a contractor selected to perform the Construction Contract.

§ 4 Failure on the part of the Owner to comply with the notice requirement in Section 3.1 shall not constitute a failure to comply with a condition precedent to the Surety's obligations, or release the Surety from its obligations, except to the extent the Surety demonstrates actual prejudice.

§ 5 When the Owner has satisfied the conditions of Section 3, the Surety shall promptly and at the Surety's expense take one of the following actions:

§ 5.1 Arrange for the Contractor, with the consent of the Owner, to perform and complete the Construction Contract;

§ 5.2 Undertake to perform and complete the Construction Contract itself, through its agents or independent contractors;

§ 5.3 Obtain bids or negotiated proposals from qualified contractors acceptable to the Owner for a contract for performance and completion of the Construction Contract, arrange for a contract to be prepared for execution by the Owner and a contractor selected with the Owner's concurrence, to be secured with performance and payment bonds executed by a qualified surety equivalent to the bonds issued on the Construction Contract, and pay to the Owner the amount of damages as described in Section 7 in excess of the Balance of the Contract Price incurred by the Owner as a result of the Contractor Default; or

§ 5.4 Waive its right to perform and complete, arrange for completion, or obtain a new contractor and with reasonable promptness under the circumstances:

- .1 After investigation, determine the amount for which it may be liable to the Owner and, as soon as practicable after the amount is determined, make payment to the Owner; or
- .2 Deny liability in whole or in part and notify the Owner, citing the reasons for denial.

§ 6 If the Surety does not proceed as provided in Section 5 with reasonable promptness, the Surety shall be deemed to be in default on this Bond seven days after receipt of an additional written notice from the Owner to the Surety demanding that the Surety perform its obligations under this Bond, and the Owner shall be entitled to enforce any remedy available to the Owner. If the Surety proceeds as provided in Section 5.4, and the Owner refuses the payment or the Surety has denied liability, in whole or in part, without further notice the Owner shall be entitled to enforce any remedy available to the Owner.

§ 7 If the Surety elects to act under Section 5.1, 5.2 or 5.3, then the responsibilities of the Surety to the Owner shall not be greater than those of the Contractor under the Construction Contract, and the responsibilities of the Owner to the

Surety shall not be greater than those of the Owner under the Construction Contract. Subject to the commitment by the Owner to pay the Balance of the Contract Price, the Surety is obligated, without duplication, for

- .1 the responsibilities of the Contractor for correction of defective work and completion of the Construction Contract;
- .2 additional legal, design professional and delay costs resulting from the Contractor's Default, and resulting from the actions or failure to act of the Surety under Section 5; and
- .3 liquidated damages, or if no liquidated damages are specified in the Construction Contract, actual damages caused by delayed performance or non-performance of the Contractor.

§ 8 If the Surety elects to act under Section 5.1, 5.3 or 5.4, the Surety's liability is limited to the amount of this Bond.

§ 9 The Surety shall not be liable to the Owner or others for obligations of the Contractor that are unrelated to the Construction Contract, and the Balance of the Contract Price shall not be reduced or set off on account of any such unrelated obligations. No right of action shall accrue on this Bond to any person or entity other than the Owner or its heirs, executors, administrators, successors and assigns.

§ 10 The Surety hereby waives notice of any change, including changes of time, to the Construction Contract or to related subcontracts, purchase orders and other obligations.

§ 11 Any proceeding, legal or equitable, under this Bond may be instituted in any court of competent jurisdiction in the location in which the work or part of the work is located and shall be instituted within two years after a declaration of Contractor Default or within two years after the Contractor ceased working or within two years after the Surety refuses or fails to perform its obligations under this Bond, whichever occurs first. If the provisions of this Paragraph are void or prohibited by law, the minimum period of limitation available to sureties as a defense in the jurisdiction of the suit shall be applicable.

§ 12 Notice to the Surety, the Owner or the Contractor shall be mailed or delivered to the address shown on the page on which their signature appears.

§ 13 When this Bond has been furnished to comply with a statutory or other legal requirement in the location where the construction was to be performed, any provision in this Bond conflicting with said statutory or legal requirement shall be deemed deleted herefrom and provisions conforming to such statutory or other legal requirement shall be deemed incorporated herein. When so furnished, the intent is that this Bond shall be construed as a statutory bond and not as a common law bond.

§ 14 Definitions

§ 14.1 **Balance of the Contract Price.** The total amount payable by the Owner to the Contractor under the Construction Contract after all proper adjustments have been made, including allowance to the Contractor of any amounts received or to be received by the Owner in settlement of insurance or other claims for damages to which the Contractor is entitled, reduced by all valid and proper payments made to or on behalf of the Contractor under the Construction Contract.

§ 14.2 **Construction Contract.** The agreement between the Owner and Contractor identified on the cover page, including all Contract Documents and changes made to the agreement and the Contract Documents.

§ 14.3 **Contractor Default.** Failure of the Contractor, which has not been remedied or waived, to perform or otherwise to comply with a material term of the Construction Contract.

§ 14.4 **Owner Default.** Failure of the Owner, which has not been remedied or waived, to pay the Contractor as required under the Construction Contract or to perform and complete or comply with the other material terms of the Construction Contract.

§ 14.5 **Contract Documents.** All the documents that comprise the agreement between the Owner and Contractor.

§ 15 If this Bond is issued for an agreement between a Contractor and subcontractor, the term Contractor in this Bond shall be deemed to be Subcontractor and the term Owner shall be deemed to be Contractor.

§ 16 Modifications to this bond are as follows:

<< >>

(Space is provided below for additional signatures of added parties, other than those appearing on the cover page.)

CONTRACTOR AS PRINCIPAL

Company: _____ (Corporate Seal)

Signature: _____

Name and Title: << >><< >> _____

Address: << >> _____

SURETY

Company: _____ (Corporate Seal)

Signature: _____

Name and Title: << >><< >> _____

Address: << >> _____



DRAFT AIA® Document A312™ - 2010

Payment Bond

CONTRACTOR:

(Name, legal status and address)

« »« »
« »

SURETY:

(Name, legal status and principal place of business)

« »« »
« »

OWNER:

(Name, legal status and address)

«Yonkers Joint Schools Construction Board»«»
«City Hall
40 South Broadway
Yonkers, NY 10701»

CONSTRUCTION CONTRACT

Date: « »

Amount: \$ «0.00»

Description:

(Name and location)

«Community School 35»
«121 McLean Avenue,
Yonkers, NY 10705»

BOND

Date:

(Not earlier than Construction Contract Date)

« »

Amount: \$ « »

Modifications to this Bond: None See Section 18

CONTRACTOR AS PRINCIPAL

Company: (Corporate Seal)

SURETY

Company: (Corporate Seal)

Signature:

Name and « »« »

Title:

(Any additional signatures appear on the last page of this Payment Bond.)

Signature:

Name and « »« »

Title:

(FOR INFORMATION ONLY — Name, address and telephone)

AGENT or BROKER:

« »
« »
« »

OWNER'S REPRESENTATIVE:

(Architect, Engineer or other party:)

«Mayor Mike Spano »

«»
«»
«»
«»

ADDITIONS AND DELETIONS: The author of this document has added information needed for its completion. The author may also have revised the text of the original AIA standard form. An *Additions and Deletions Report* that notes added information as well as revisions to the standard form text is available from the author and should be reviewed.

This document has important legal consequences. Consultation with an attorney is encouraged with respect to its completion or modification.

Any singular reference to Contractor, Surety, Owner or other party shall be considered plural where applicable.

§ 1 The Contractor and Surety, jointly and severally, bind themselves, their heirs, executors, administrators, successors and assigns to the Owner to pay for labor, materials and equipment furnished for use in the performance of the Construction Contract, which is incorporated herein by reference, subject to the following terms.

§ 2 If the Contractor promptly makes payment of all sums due to Claimants, and defends, indemnifies and holds harmless the Owner from claims, demands, liens or suits by any person or entity seeking payment for labor, materials or equipment furnished for use in the performance of the Construction Contract, then the Surety and the Contractor shall have no obligation under this Bond.

§ 3 If there is no Owner Default under the Construction Contract, the Surety's obligation to the Owner under this Bond shall arise after the Owner has promptly notified the Contractor and the Surety (at the address described in Section 13) of claims, demands, liens or suits against the Owner or the Owner's property by any person or entity seeking payment for labor, materials or equipment furnished for use in the performance of the Construction Contract and tendered defense of such claims, demands, liens or suits to the Contractor and the Surety.

§ 4 When the Owner has satisfied the conditions in Section 3, the Surety shall promptly and at the Surety's expense defend, indemnify and hold harmless the Owner against a duly tendered claim, demand, lien or suit.

§ 5 The Surety's obligations to a Claimant under this Bond shall arise after the following:

§ 5.1 Claimants, who do not have a direct contract with the Contractor,

- .1 have furnished a written notice of non-payment to the Contractor, stating with substantial accuracy the amount claimed and the name of the party to whom the materials were, or equipment was, furnished or supplied or for whom the labor was done or performed, within ninety (90) days after having last performed labor or last furnished materials or equipment included in the Claim; and
- .2 have sent a Claim to the Surety (at the address described in Section 13).

§ 5.2 Claimants, who are employed by or have a direct contract with the Contractor, have sent a Claim to the Surety (at the address described in Section 13).

§ 6 If a notice of non-payment required by Section 5.1.1 is given by the Owner to the Contractor, that is sufficient to satisfy a Claimant's obligation to furnish a written notice of non-payment under Section 5.1.1.

§ 7 When a Claimant has satisfied the conditions of Sections 5.1 or 5.2, whichever is applicable, the Surety shall promptly and at the Surety's expense take the following actions:

§ 7.1 Send an answer to the Claimant, with a copy to the Owner, within sixty (60) days after receipt of the Claim, stating the amounts that are undisputed and the basis for challenging any amounts that are disputed; and

§ 7.2 Pay or arrange for payment of any undisputed amounts.

§ 7.3 The Surety's failure to discharge its obligations under Section 7.1 or Section 7.2 shall not be deemed to constitute a waiver of defenses the Surety or Contractor may have or acquire as to a Claim, except as to undisputed amounts for which the Surety and Claimant have reached agreement. If, however, the Surety fails to discharge its obligations under Section 7.1 or Section 7.2, the Surety shall indemnify the Claimant for the reasonable attorney's fees the Claimant incurs thereafter to recover any sums found to be due and owing to the Claimant.

§ 8 The Surety's total obligation shall not exceed the amount of this Bond, plus the amount of reasonable attorney's fees provided under Section 7.3, and the amount of this Bond shall be credited for any payments made in good faith by the Surety.

§ 9 Amounts owed by the Owner to the Contractor under the Construction Contract shall be used for the performance of the Construction Contract and to satisfy claims, if any, under any construction performance bond. By the Contractor furnishing and the Owner accepting this Bond, they agree that all funds earned by the Contractor in the performance of the Construction Contract are dedicated to satisfy obligations of the Contractor and Surety under this Bond, subject to the Owner's priority to use the funds for the completion of the work.

§ 10 The Surety shall not be liable to the Owner, Claimants or others for obligations of the Contractor that are unrelated to the Construction Contract. The Owner shall not be liable for the payment of any costs or expenses of any Claimant under this Bond, and shall have under this Bond no obligation to make payments to, or give notice on behalf of, Claimants or otherwise have any obligations to Claimants under this Bond.

§ 11 The Surety hereby waives notice of any change, including changes of time, to the Construction Contract or to related subcontracts, purchase orders and other obligations.

§ 12 No suit or action shall be commenced by a Claimant under this Bond other than in a court of competent jurisdiction in the state in which the project that is the subject of the Construction Contract is located or after the expiration of one year from the date (1) on which the Claimant sent a Claim to the Surety pursuant to Section 5.1.2 or 5.2, or (2) on which the last labor or service was performed by anyone or the last materials or equipment were furnished by anyone under the Construction Contract, whichever of (1) or (2) first occurs. If the provisions of this Paragraph are void or prohibited by law, the minimum period of limitation available to sureties as a defense in the jurisdiction of the suit shall be applicable.

§ 13 Notice and Claims to the Surety, the Owner or the Contractor shall be mailed or delivered to the address shown on the page on which their signature appears. Actual receipt of notice or Claims, however accomplished, shall be sufficient compliance as of the date received.

§ 14 When this Bond has been furnished to comply with a statutory or other legal requirement in the location where the construction was to be performed, any provision in this Bond conflicting with said statutory or legal requirement shall be deemed deleted herefrom and provisions conforming to such statutory or other legal requirement shall be deemed incorporated herein. When so furnished, the intent is that this Bond shall be construed as a statutory bond and not as a common law bond.

§ 15 Upon request by any person or entity appearing to be a potential beneficiary of this Bond, the Contractor and Owner shall promptly furnish a copy of this Bond or shall permit a copy to be made.

§ 16 Definitions

§ 16.1 Claim. A written statement by the Claimant including at a minimum:

- .1 the name of the Claimant;
- .2 the name of the person for whom the labor was done, or materials or equipment furnished;
- .3 a copy of the agreement or purchase order pursuant to which labor, materials or equipment was furnished for use in the performance of the Construction Contract;
- .4 a brief description of the labor, materials or equipment furnished;
- .5 the date on which the Claimant last performed labor or last furnished materials or equipment for use in the performance of the Construction Contract;
- .6 the total amount earned by the Claimant for labor, materials or equipment furnished as of the date of the Claim;
- .7 the total amount of previous payments received by the Claimant; and
- .8 the total amount due and unpaid to the Claimant for labor, materials or equipment furnished as of the date of the Claim.

§ 16.2 Claimant. An individual or entity having a direct contract with the Contractor or with a subcontractor of the Contractor to furnish labor, materials or equipment for use in the performance of the Construction Contract. The term Claimant also includes any individual or entity that has rightfully asserted a claim under an applicable mechanic's lien or similar statute against the real property upon which the Project is located. The intent of this Bond shall be to include without limitation in the terms "labor, materials or equipment" that part of water, gas, power, light, heat, oil, gasoline, telephone service or rental equipment used in the Construction Contract, architectural and engineering services required for performance of the work of the Contractor and the Contractor's subcontractors, and all other items for which a mechanic's lien may be asserted in the jurisdiction where the labor, materials or equipment were furnished.

§ 16.3 Construction Contract. The agreement between the Owner and Contractor identified on the cover page, including all Contract Documents and all changes made to the agreement and the Contract Documents.

§ 16.4 **Owner Default.** Failure of the Owner, which has not been remedied or waived, to pay the Contractor as required under the Construction Contract or to perform and complete or comply with the other material terms of the Construction Contract.

§ 16.5 **Contract Documents.** All the documents that comprise the agreement between the Owner and Contractor.

§ 17 If this Bond is issued for an agreement between a Contractor and subcontractor, the term Contractor in this Bond shall be deemed to be Subcontractor and the term Owner shall be deemed to be Contractor.

§ 18 Modifications to this bond are as follows:

<< >>

(Space is provided below for additional signatures of added parties, other than those appearing on the cover page.)

CONTRACTOR AS PRINCIPAL

Company: _____ (Corporate Seal)

Signature: _____

Name and Title: << >><> >>

Address: << >>

SURETY

Company: _____ (Corporate Seal)

Signature: _____

Name and Title: << >><> >>

Address: << >>

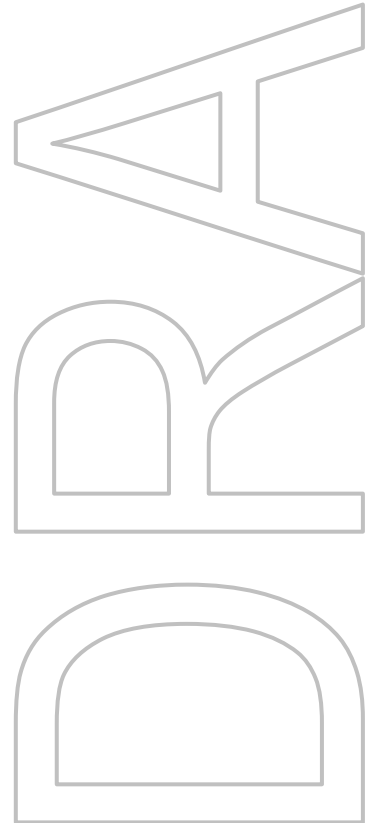

13 January 2022
Conformed Specifications
SED #66-23-00-01-0-346-001

Yonkers Joint Schools Construction Board
Community School 35

**YONKERS JOINT SCHOOLS CONSTRUCTION BOARD MINORITY AND WOMAN-OWNED
BUSINESS ENTERPRISE AND WORKFORCE UTILIZATION FORMS**

See the following pages for the instructions and the forms required to be submitted by the Contractor after the bid is awarded.

Yonkers Joint School Construction Board

Required Diversification Documents to be submitted AFTER bid is awarded

Minority and Woman-Owned Business Enterprise and Workforce Utilization Forms

Table of Contents

	Page(s)
Instructions for YJSCB Utilization Plan	1 – 2
YJSCB Utilization Plan (submit once bid is awarded)	3 – 8
Utilization Plan Excel Spreadsheet Original (submit when there is a change to MWBE contract value)	4
Instructions for YJSCB Scope Verification Form	9
MWBE Subcontractor Scope Verification Form	10
Instructions for YJSCB Form C	11 - 12
YJSCB Form C (Contractor’s MWBE Monthly Report)	13
Instructions for YJSCB Form E	14 – 15
YJSCB Form E (Monthly EEO-Workforce Utilization Report)	16
YJSCB Form B (FINAL MWBE Utilization Report)	17

Instructions for YJSCB Utilization Plan Form

The YJSCB Utilization Plan must be completed by the Prime Contractor

Page 1

PRIME INFORMATION: Please select company service category. Enter full name of company, address, contact person, email address and contact phone number.

PROJECT INFORMATION: Please enter the Contract/Bid dollar amount.

Enter the MBE goal dollar value.

Enter the WBE goal dollar value.

Enter the name of the school and/or the building if separate from the school.

Enter the address, city, county and zip code

Enter a brief description of the work to be completed

PROPOSED MWBE UTILIZATION: Complete and submit original Excel MWBE Utilization spreadsheet included as part of the diversity document package. See instructions for Page 2.

WORKFORCE GOAL PLAN FOR MINORITY AND FEMALE: You will need to submit a descriptive narrative for your firm and for **each subcontractor** that will contribute towards goal achievement. **Information provided must include: the name of the contractor/sub-contractor, the trade, the projected workforce utilization for minority and female workers.** **Workforce plan should be submitted on subcontractor letterhead.**

Type the name of Principal or Officer completing this form.

Type the title of Principal or Officer completing this form

Principal or Officer must sign and date this form.

Page 2

Please utilize the Excel version of page 2 and submit the original with your plan.

List ALL subcontractors and suppliers that you plan to utilize during the performance of this contract.

Enter the complete firm name, a brief work description, the value of the proposed subcontractor contract, the name of the contact person, the telephone number of the contact person, the email address of the contact person, complete address of the firm. Please include the estimated start date for the work this firm will perform, and whether they are an MBE firm, a WBE firm or other firm. If additional space is needed, please contact Landon & Rian Enterprise.

Type the name of Principal or Officer completing this form.

Type the title of Principal or Officer completing this form

Principal or Officer must sign and date this form.

Page 3 – Standard Equal Opportunity Policy Statement

Indicate whether you are a Prime Contractor or Prime Consultant.

Enter the full name of the firm, the complete address, city, state and zip code.

Enter the name of the person to be contacted regarding the Utilization Form and their telephone number. This person should be prepared to answer questions regarding this plan.

Enter the name of the school and/or the building if separate from the school

Enter the address, city, county and zip code

Enter a brief description of the work to be completed

Enter the full name of the firm completing this Plan in each of the spaces provided.

Page 4 – MWBE and EEO Contract Goals

Please enter initials of the person completing this form for MWBE and EEO Contract Goals

Type the name of Principal or Officer completing this form.

Type the title of Principal or Officer completing this form

Principal or Officer must sign and date this form.

Page 5 - Request for Waiver

Please indicate whether this is a request for a total waiver, a partial waiver or N/A because the goals are met.

Enter the % waiver requested from MBE goals

Enter the % waiver requested from WBE goals.

1. Enter your statement of justification to support the request for a waiver of the goal requirements established by the Contract Documents. If additional space is needed, please contact Landon & Rian Enterprises.
2. Follow the guidelines on page 6. Provide proof for each guideline in an item-by-item format following the numerical sequence. DO NOT LEAVE ANY UNDOCUMENTED ITEMS. Failure to adequately document and respond to each item will result in your request for waiver being rejected. "Good Faith Effort" documentation will be verified by the ICO.

Submit the complete Utilization Plan and all supporting documentation to:

Landon & Rian Enterprises, Inc.

Ldickerson@landonrian.com, pwilkerson@landonrian.com and sbeaumont@landonrian.com

UTILIZATION PLAN

ORIGINAL Submission

REVISED Submission

A. PRIME INFORMATION: CONTRACTOR

CONSULTANT

Name: _____
 Address: _____ City: _____ State: _____ Zip: _____
 Contact Person: _____ Email: _____ Phone #: _____

PROJECT INFORMATION:

Contract/Bid Amount: \$

MBE Goal = 20% \$

WBE Goal = 10% \$

School/Building(s) Name: _____
 Address: _____
 City: _____ County: _____ Zip: _____
 Work Description: _____

B. PROPOSED MWBE UTILIZATION:

Complete and submit original Excel MWBE Utilization spreadsheet included as part of the diversity document package. See example on page 2.

C. WORKFORCE GOAL PLAN FOR MINORITY AND FEMALE

Please describe plans to meet the 30% Minority and Female YJSCB Goal.

You will need to submit a descriptive narrative for your firm and for **each subcontractor** that will contribute towards goal achievement. Information provided must include: the name of the contractor/sub-contractor, the trade, the projected workforce utilization for minority and female workers.

Please see the example below. **Workforce plan should be submitted on subcontractor letterhead.**

Name of Firm: ABC Construction

Trade: drywall, painting, etc.

Workforce:

- 7 full time (40 hour per week) and 1 part time (25 hours per week) minority employees
- 3 full time (40 hour per week) non-minority female employees
- 2 full time (40 hour per week) minority female employees

Type Name of Principal or Officer

Type Title of Principal or Officer

Date

B. List **ALL** subcontractors and suppliers you plan to utilize during the performance of this contract:

***NOTE: A completed Scope Verification Form YJSCB (10/06/2021) must accompany this Utilization Plan for each MWBE subcontractor and/or supplier listed. A blank form is included in the Contract Documents. Incomplete or nonsubmittal of the form(s) will delay approval of the Utilization Plan.

School Name here

Contract Amount:

Subcontractor Listing - Utilization Plan

MWBE Goal Calculation	
20%	10%
MBE	WBE

Contractor Name	Work Description	Contract Value	Contact Person	Telephone	Email Address	Address	City	State	Zip	Estimated Start Date	Type of Firm			Scope Verification submitted	Workforce Plan Submitted
											MBE	WBE	Other		
SUBCONTRACTORS															

SUPPLIERS <small>(Please Note that 50% of supplier contract values are counted toward the goal)</small>															

Name of Principal or Officer

Title of Principal or Officer

Signature of Principal or Officer

Date

Credit	\$	0	\$	0
Goal	\$	-	\$	-
Over/(Shortfall)	\$	0	\$	0
Waiver	#DIV/0!		#DIV/0!	

D. STANDARD EQUAL OPPORTUNITY POLICY STATEMENT

AFTER bid is awarded

PRIME INFORMATION: CONTRACTOR CONSULTANT

Name:

Address:

City:

State:

Zip:

Contact Person:

Telephone:

PROJECT INFORMATION:

School/Building(s) Name:

Address:

City:

County:

Zip:

Work Description:

The following is a statement of _____'s commitment to provide participation by minority persons and women in the workforce at the above referenced project:

Will ensure and maintain a working environment free of harassment, intimidation and coercion and shall specifically ensure that all foremen, superintendents and other supervisory personnel are aware of and carry out our commitment to maintain such a working environment.

Will establish and maintain a current list of minority and women recruitment sources and notify such sources and minority and community organizations when employment opportunities are available and maintain a record of the sources and organizations' responses.

Will maintain a file of the names and address of each minority person and woman referred to it by any individual, recruitment source or community organization and of what action was taken with respect to each such referred individual. If the individual was not employed, the file will contain the reasons.

Will disseminate this equal employment opportunity policy statement within the organization and will provide all subcontractors with a copy, discussing it with them prior to commencing work at the job site. A copy of our equal employment policy shall be posted at the job site at all times.

Please initial below in acknowledgment of the individual participation goals per the YJSCB Diversification Plan.

MWBE Contract Goals

30% Minority and Women's Business Enterprise Participation

20% Minority Business Enterprise Participation

10% Women's Business Enterprise Participation

EEO Contract Goals

20% Minority Labor Force Participation

10% Female Labor Force Participation

Type Name of Principal or Officer

Type Title of Principal or Officer

Signature of Principal or Officer

Date

E. REQUEST FOR WAIVER

TOTAL WAIVER

PARTIAL WAIVER

N/A – GOALS ARE MET

MBE Waiver (%) Requested

WBE Waiver (%) Requested

NOTE: On Yonkers Joint Schools Construction Board (YSCB) Contracts, the overall goal percentages are applied to the entire contract dollar value. Therefore, if a waiver is requested for an individual work order, it is your responsibility to make up the shortfall on future work orders in order to maintain the overall MWBE goal percentage for the contract. In addition, your firm should maintain a record of the MWBE goal attainment for the overall contract which may be requested by the ICO at any given time. Failure to do so may jeopardize the award of future work orders.

1. Provide a statement of justification to support the request for a waiver of the goal requirements established by the Contract Documents.

2. “Good Faith Effort” Guidelines

The following guidelines must be used for the preparation of ALL “good faith effort” documentation. The responses to the information in the Guidelines should be given in an item-by-item format following the numerical sequence as presented and accompany the Utilization Plan. “Good Faith Effort” documentation will be verified by the ICO.

IF YOU FAIL TO ADEQUATELY DOCUMENT AND RESPOND TO EACH ITEM ON THE GOOD FAITH EFFORT GUIDELINES, THE REQUEST FOR WAIVER WILL BE DEEMED NON-RESPONSIVE, INCOMPLETE AND WILL BE REJECTED.

For Office Use Only

Independent Compliance Officer Name

Signature of ICO

Date

1. Attach a copy of the completed Utilization Plan in accordance with MWBE goals established in the Contract Documents.
2. Submit a written request for a list of trade and/or service specific MWBE's, certified by Empire State Development, from the Independent Compliance Officer for subcontracting and procurement opportunities.
3. Contact all Empire State Development certified MWBE's posted in the list of certified subcontractors and suppliers posted on the New York State website: <https://ny.newnycontracts.com/>
4. Provide a record of advertisements placed in general circulation, trade and minority and women oriented publications. Include the name of publications and dates of advertisements.
5. Submit documentation that clearly demonstrates that you contacted all the MWBE's identified through the outreach activities outlined above to determine their capacity to perform the applicable scope of work. Include in your documentation a listing of the outreach measures, the results of your outreach and the responses received.
6. Provide a record of ALL written solicitations made to Empire State Development certified minority and women-owned business enterprises obtained from the directory of certified businesses and/or the outreach efforts specified above. Include dates and copies of solicitations made.
7. Provide a record of ALL responses received from Empire State Development certified minority or women owned business enterprises to any such advertisements and solicitations made. Include dates and copies of any written responses.
8. Provide a list of any pre-bid, pre-award, or other meetings attended with Empire State Development certified minority or women owned businesses.
9. List the efforts undertaken to subdivide portions of the work into smaller components in order to increase Empire State Development certified minority and women-owned business enterprise participation.
10. Did your firm seek additional assistance from the Independent Compliance Officer ? If yes, please provide supportive documentation of your interaction.
11. Provide a description of all relevant contract documents, plans or specifications, or documents describing the scope of work which was made available to Empire State Development certified minority and women-owned business enterprises for the purpose of soliciting their bids. Include the dates and manner in which these documents were made available.
12. Were the same subcontract terms and conditions offered to Empire State Development certified minority and women-owned business enterprises as those offered in the ordinary course of business and to other subcontractors?
13. Did you negotiate with Empire State Development certified MWBE firms whose quotes originally submitted were deemed as too high? Provide written documentation, including the schedule of values, detailing this interaction.
14. Has your firm made payments for work performed by Empire State Development certified minority and women-owned business enterprises in a timely fashion for past work and/or past projects so as to facilitate continued performance by the certified businesses?
15. List any special considerations and/or concerns, which are preventing adequate Empire State Development certified minority and women-owned business enterprises to participate?
16. Have you successfully met or exceeded MWBE goals on another project? Provide detailed documentation. If not, please explain in detail including the project name, location, goals, actual MWBE participation and reasons goals were not achieved.

Instructions for YJSCB Scope Verification Form

PROJECT INFORMATION

School: Specify individual school building

SED#: Specify SED Number

PRIME CONTRACTOR

Enter the Prime Contractor's full company name, contact person, contact phone number, and email address in the spaces provided.

MWBE SUBCONTRACTOR

Specify MWBE status. Enter the full company name, contact person, contact phone number, and email address in the spaces provided.

SUBCONTRACTOR SCOPE OF SERVICES

Certified to Perform: Enter the scope of work they are certified to perform

Description of Work: provide a detailed scope of services to be performed by the proposed MWBE Firm listed.

Price: Enter the proposed contract value for the services of the proposed MWBE Firm listed.

MWBE SUBCONTRACTOR
SCOPE VERIFICATION FORM

This form must be submitted with the Utilization Plan for each MWBE subcontractor listed on the Utilization Plan. Failure to submit will delay acceptance of the Utilization Plan and award of the Contract. Please make copies as needed.

A. PROJECT INFORMATION	
School:	
SED #	

B. PRIME CONTRACTOR	C. MWBE SUBCONTRACTOR	MBE	WBE
COMPANY:	COMPANY:		
CONTACT:	CONTACT:		
TELEPHONE:	TELEPHONE:		
E-MAIL:	E-MAIL:		

D. MWBE SUBCONTRACTOR SCOPE OF SERVICES

In the box below, provide a detailed scope of services to be performed by the proposed MWBE Subcontractor listed above.

Certified to Perform	DESCRIPTION OF WORK	Contract Amount	Anticipated Start Date	Anticipated End Date

The official schedule of values for the above scope of services must be submitted along with the applicable subcontract agreement within 10 days of the Utilization Plan approval.

MWBE FIRM

PRIME CONTRACTOR

Print Name of Principal or Officer

Print Title of Principal or Officer

Signature of Principal or Officer

Signature of Principal or Officer

Date

Date

Instructions for YJSCB Form C

NOTE: Gray shaded areas contain self-calculating formulas. **DO NOT** enter information in these cells

Month: Pay Application reporting month

Contractor: Specify Contractor/Sub-contractor Name

School Name #: Specify School

Contract Amount: Enter Contract amount

Amount Paid to Prime Contractor this Month: The amount paid to the Prime Contractor/Consultant by the YJSCB for the Pay Application Reporting Month

MBE Goal: 20%

MBE Amount: This is automatically calculated. **DO NOT** enter information here

WBE Goal: 10%

WBE Amount: This is automatically calculated. **DO NOT** enter information here

“Subcontractor” column:

Please list all subcontractors and sub-consultants that are being utilized on this project. This includes MBE, WBE, and non-MWBE firms, currently active, currently inactive, and firms that have completed their scope of work. *Note: All firms must be on the latest approved Utilization Plan. If you have new firms, you MUST submit a revised Utilization Plan to the ICO within 5 business days.*

“Work Status this Report”:

Please indicate whether the subcontractor/sub-consultant is currently “Active”, “Inactive” or “Complete” (has completed their scope of work and all payments have been made to the subcontractor/sub-consultant).

“Total Subcontract Amount \$”:

Enter the total value of the subcontract that is listed on your latest approved Utilization Plan. *Note: If this amount has changed, you must submit a revised Utilization Plan to the ICO within 5 business days.*

“Payments This Month”:

Enter the total amount paid to the respective M/WBE subcontractor/sub-consultant. **The payments listed must have corresponding invoices and cancelled checks/eDeposit log/direct deposit log/wire transfer log included as verification of payment.**

“Previous Payments”:

Enter all previous payments made to the M/WBE subcontractor or sub-consultant that have been reported prior to this reporting month.

“Total Payment Made to Date”: **DO NOT** enter any information in these columns. These cells contain self-calculating formulas.

“% To Date”: **DO NOT** enter any information in these columns. These cells contain self-calculating formulas.

Please Sign and Date at the bottom of the form before submission so that processing is not delayed

CONTRACTOR'S MINORITY AND WOMEN'S BUSINESS (MWBE) MONTHLY REPORT

MONTH	<input type="text"/>	YEAR	<input type="text"/>	CONTRACTOR			<input type="text"/>									
SCHOOL NAME	<input type="text"/>	CONTRACT AMOUNT	<input type="text"/>	AMOUNT PAID TO PRIME CONTRACTOR THIS MONTH			<input type="text"/>									
MBE Goal	20.00%	MBE Amount:	\$0.00	WBE Goal:	10.00%	WBE Amount:	\$	-								
Subcontractor	Work Status This Report	Total Subcontract Amount \$			Payments This Month \$			Previous Payments \$			Total Payment Made to Date \$			% To Date		
		Non M/WBE	MBE	WBE	Non M/WBE	MBE	WBE	Non M/WBE	MBE	WBE	Non M/WBE	MBE	WBE	Non MWBE	MBE	WBE
	<input type="checkbox"/> Active <input type="checkbox"/> Inactive <input type="checkbox"/> Complete	\$ -	\$ -	\$ -	\$ -	\$ -	\$ -	\$ -	\$ -	\$ -	\$ -	\$ -	\$ -			
	<input type="checkbox"/> Active <input type="checkbox"/> Inactive <input type="checkbox"/> Complete	\$ -	\$ -	\$ -	\$ -	\$ -	\$ -	\$ -	\$ -	\$ -	\$ -	\$ -	\$ -			
	<input type="checkbox"/> Active <input type="checkbox"/> Inactive <input type="checkbox"/> Complete	\$ -	\$ -	\$ -	\$ -	\$ -	\$ -	\$ -	\$ -	\$ -	\$ -	\$ -	\$ -			
	<input type="checkbox"/> Active <input type="checkbox"/> Inactive <input type="checkbox"/> Complete	\$ -	\$ -	\$ -	\$ -	\$ -	\$ -	\$ -	\$ -	\$ -	\$ -	\$ -	\$ -			
	<input type="checkbox"/> Active <input type="checkbox"/> Inactive <input type="checkbox"/> Complete	\$ -	\$ -	\$ -	\$ -	\$ -	\$ -	\$ -	\$ -	\$ -	\$ -	\$ -	\$ -			
	<input type="checkbox"/> Active <input type="checkbox"/> Inactive <input type="checkbox"/> Complete	\$ -	\$ -	\$ -	\$ -	\$ -	\$ -	\$ -	\$ -	\$ -	\$ -	\$ -	\$ -			
	<input type="checkbox"/> Active <input type="checkbox"/> Inactive <input type="checkbox"/> Complete	\$ -	\$ -	\$ -	\$ -	\$ -	\$ -	\$ -	\$ -	\$ -	\$ -	\$ -	\$ -			
	<input type="checkbox"/> Active <input type="checkbox"/> Inactive <input type="checkbox"/> Complete	\$ -	\$ -	\$ -	\$ -	\$ -	\$ -	\$ -	\$ -	\$ -	\$ -	\$ -	\$ -			
	<input type="checkbox"/> Active <input type="checkbox"/> Inactive <input type="checkbox"/> Complete	\$ -	\$ -	\$ -	\$ -	\$ -	\$ -	\$ -	\$ -	\$ -	\$ -	\$ -	\$ -			
	<input type="checkbox"/> Active <input type="checkbox"/> Inactive <input type="checkbox"/> Complete	\$ -	\$ -	\$ -	\$ -	\$ -	\$ -	\$ -	\$ -	\$ -	\$ -	\$ -	\$ -			
	<input type="checkbox"/> Active <input type="checkbox"/> Inactive <input type="checkbox"/> Complete	\$ -	\$ -	\$ -	\$ -	\$ -	\$ -	\$ -	\$ -	\$ -	\$ -	\$ -	\$ -			
	<input type="checkbox"/> Active <input type="checkbox"/> Inactive <input type="checkbox"/> Complete	\$ -	\$ -	\$ -	\$ -	\$ -	\$ -	\$ -	\$ -	\$ -	\$ -	\$ -	\$ -			
	<input type="checkbox"/> Active <input type="checkbox"/> Inactive <input type="checkbox"/> Complete	\$ -	\$ -	\$ -	\$ -	\$ -	\$ -	\$ -	\$ -	\$ -	\$ -	\$ -	\$ -			
	<input type="checkbox"/> Active <input type="checkbox"/> Inactive <input type="checkbox"/> Complete	\$ -	\$ -	\$ -	\$ -	\$ -	\$ -	\$ -	\$ -	\$ -	\$ -	\$ -	\$ -			
TOTAL		\$ -	\$ -	\$ -	\$ -	\$ -	\$ -	\$ -	\$ -	\$ -	\$ -	\$ -	\$ -			

Signature

Date

Reports must include subcontractor invoice for payment and proof of payment from contractor

Instructions for YJSCB Form E

Contract # and School: Specify Contract # and School

Contractor: Specify Contractor/Sub-contractor Name

Contract Amount: Enter Contract amount

Reporting Period: Specify period of time reporting

Column “(A) Job or Trade Category”:

Enter title of Job or Trade category as needed in spaces provided.”

Column “(B) Total Employee Hours”:

Hours are automatically calculated. Do not need to enter anything.

Column “(C) Caucasian”:

Enter total number of hours worked, for each job category, for Caucasian Male employees and Caucasian Female employees, in their respective columns.

Column “(D) Black (Not of Hispanic Origin)”:

Enter total number of hours worked, for each job category, for Black Non-Hispanic Male employees and Black Non-Hispanic Female employees, in their respective columns.

Column “(E) Hispanic:

Enter total number of hours worked, for each job category, for Hispanic Male employees and Hispanic Female employees, in their respective columns.

Column “(F) Asian or Pacific Islander:

Enter total number of hours worked, for each job category, for Asian or Pacific Islander Male employees and Asian or Pacific Islander Female employees, in their respective columns.

Column “(G) Native American or Alaskan Native:

Enter total number of hours worked, for each job category, for Native American or Alaskan Native Male employees and Native American or Alaskan Native Female employees, in their respective columns.

Column “(H) Total # of Employees:

Enter total number of employees. ***Include all male, female, Caucasian and minority employees.***

Column “(I) Total # of Minority Employees:

Enter total number of ***minority*** employees. Include all male and female, minority employees.

Column “(J) Minority %”:

Automatically calculated. Do not need to enter anything.

Column “(K) Female %”:

Automatically calculated. Do not need to enter anything.

Monthly EEO-Work Force Utilization Report

Contract # and School: _____
Contractor: _____

Contract Amount: _____
Reporting Period: _____

(A) Job or Trade Category (add as needed)	Total Hours Worked During Reporting Period for Contract												(H) Total # of Employees		(I) Total # of Minority Employees		(J) Minority %	(K) Female %
	(B) Total Employee Hours		(C) Caucasian		(D) Black (Not of Hispanic Origin)		(E) Hispanic		(F) Asian or Pacific Islander		(G) Native American or Alaskan Native							
	Male	Female	Male	Female	Male	Female	Male	Female	Male	Female	Male	Female	Male	Fem.	Male	Fem.		
	0.00	0.00																
	0.00	0.00																
	0.00	0.00																
	0.00	0.00																
	0.00	0.00																
	0.00	0.00																
	0.00	0.00																
	0.00	0.00																
	0.00	0.00																
	0.00	0.00																
	0.00	0.00																
	0.00	0.00																
	0.00	0.00																
	0.00	0.00																
	0.00	0.00																
	0.00	0.00																
	0.00	0.00																
	0.00	0.00																
	0.00	0.00																
	0.00	0.00																
	0.00	0.00																
Grand Total:	0.00	0.00	0.00	0.00	0.00	0.00	0.00	0.00	0.00	0.00	0.00	0.00	0	0	0	0		

Prepared by (signature) _____
Name and Title of Preparer _____

Telephone No. _____
Fax No. _____
Mailing _____
Address _____

Date _____
Email _____

FORM B

Final MWBE Utilization Report

School Name: _____ Total Contract Amount: \$ _____

Amount of MBE Participation: \$ _____ Amount of WBE Participation: \$ _____

General/Prime Contractor Information

Name of General/Prime Contractor: _____ Phone: _____

Address: _____

I hereby certify that the above listed amount is correct and accurate to the best of my knowledge.

Name (print): _____ Title: _____

Signature: _____ (General/Prime Contractor) Date: _____

Minority/Women Business Enterprise Information

Name of MWBE: _____ MBE or WBE: _____

Address: _____ Phone: _____

Please state total amount received by the MWBE on the above-named project to date:

\$ _____ % _____

Please state the remaining balance on the above-named project to the MWBE:

\$ _____ % _____

Please state the remaining retention balance on the above-named project to the MWBE:

\$ _____

I hereby certify that the above listed amount is true and accurate to the best of my knowledge.

Name (print): _____ Title: _____

Signature _____ (Sub Contractor) Date: _____

Notary Stamp & Signature: _____

NEW YORK STATE WAGE RATE SCHEDULES

1.1 GENERAL

- A. The following minimum prevailing rate of wages, health and welfare and pension fund contributions are as determined by the Industrial Commissioner of the State of New York in accordance with the provisions of Section 220 of the Labor Law of New York State.
- B. It shall be the sole responsibility of each Contractor to pay wages at least equal to current and future Wage Rate Schedules which are applicable to this project throughout the entire duration of the Contract without claiming extra costs.
- C. Current Wage Rate Schedules are included herein. The Owner and the Architect do not warrant the accuracy or pertinency of the wage rates stated. The Contractor shall be solely responsible for verifying the accuracy of the current and future Prevailing Wage Schedule.
- D. Prevailing Rate Case Number (PRC# 2021011009 - New Community School 35) has been assigned to the project. To access the PDF file of your schedule, click on the following link or copy and paste into your browser.

<https://apps.labor.ny.gov/wpp/publicViewProject.do?method=showIt&id=1521952>

SECTION 011010 - MULTIPLE CONTRACT SUMMARY

PART 1 – GENERAL

1.1 RELATED DOCUMENTS

- A. Drawings and General provisions of the Contract, including General and Supplementary Conditions and other Division 01 Specification Sections, apply to this Section.

1.2 WORK COVERED BY CONTRACT DOCUMENTS

- A. Project Identification: Project generally consists of the Construction of a new School Building, Community Building, Appurtenant Facilities and Civil Work.
 - 1. Project Location: Former St. Denis School, Rectory and Convent Site, at 121 Mclean Ave., Yonkers, NY 10705.
 - 2. Owner: Yonkers Joint Schools Construction Board / YPS.
- B. Architect Identification: The Contract Documents, dated November 1st, 2021, were prepared for Project by: KG+D Architects, 285 Main Street Mt. Kisco, NY 10549.
- C. Construction Manager: Savin Engineers, P.C., 3 Campus Drive, Pleasantville, New York 10570, has been engaged as Construction Manager for this Project to serve as an advisor to Owner and to provide assistance in administering the Contract for Construction between Owner and each Contractor, according to a separate contract between Owner and Construction Manager.
- D. The Work consists of the construction of a new School Building and Community Building for the Yonkers Joint School Construction Board / YPS.
 - 1. The Work includes Site Work, Architectural, Civil, MEP, Structural, Masonry, Foundation and Structural Steel, partition work and associated interior wall, floor and ceiling finishes; windows and doors; casework, sidewalks, landscaping, as indicated in the Contract Documents.
 - 2. All materials, assemblies, forms and methods of construction and service equipment shall comply with the requirements of the latest edition of the New York State Building Code.

1.3 DRAWINGS INCLUDED IN CONTRACT DOCUMENTS

- A. Refer to List of Drawings located on Title Sheet of the Drawings.

1.4 CONTRACT

- A. The owner will award the following Construction Contracts for the Project in order to complete all work as indicated and specified:

Contract No. 1 Contract for General Construction

All building construction including excavation and backfill related to foundations, providing and installing all sub-drains and footing drains, all site work required to complete the exterior of the project including utilities and all finish grading and landscaping from the building perimeter to the limit of disturbance as shown on the contract documents. Contractor is to provide a complete and operational system; each prime contractor is responsible for all relevant work as shown and noted on ALL Drawings and Specifications that are part of the Contract Documents.

Contract No. 2 Plumbing & Fire Protection Contract

All Plumbing and fire protection work to complete fully operational and functional systems as shown on the contract documents and all work normally attributed to a Plumbing & Fire Protection Prime Contractor. Contractor is to provide a complete and operational system; each prime contractor is responsible for all relevant work as shown and noted on ALL Drawings and Specifications that are part of the Contract Documents.

Contract No. 3 HVAC WORK Contract

All Heating, Ventilating and Air Conditioning work to complete a fully operational and functional system as shown on the contract documents and all work normally attributed to a Mechanical Prime Contractor. Contractor is to provide a complete and operational system; each prime contractor is responsible for all relevant work as shown and noted on ALL Drawings and Specifications that are part of the Contract Documents.

Contract No. 4 Electrical Contract

All Electrical work to complete a fully operational power, lighting and other electrical systems including low voltage wiring as shown on the contract documents and normally attributed to an Electrical prime contractor. Contractor is to provide a complete and operational system; each prime contractor is responsible for all relevant work as shown and noted on ALL Drawings and Specifications that are part of the Contract Documents.

- B. In each case, the Contractor agrees to accept the site, as it exists and to remove any encumbrances, which interfere with proper fulfillment of the Work, without change in the Contract Sum.
- C. The Contractor shall cooperate with separate Contractors for any separate Contracts that the Owner may award.

1.5 MULTIPLE PRIME CONTRACTS

- A. The Project will be constructed under a multiple prime-contracting agreement. Prime Contracts are separate contracts between the Owner and separate contractors, representing significant construction activities. Each prime contract is performed concurrently with and closely coordinated with construction activities performed on the Project under other prime contracts. Prime Contracts for this Project include:

Contract No. 1	Contract for GENERAL CONSTRUCTION
Contract No. 2	PLUMBING & FIRE PROTECTION Contract
Contract No. 3	HVAC WORK Contract

Contract No. 4 ELECTRICAL Contract

- B. Contract Documents indicate the work of each prime Contract and related requirements and conditions that have an impact on the project. Related requirements and conditions that are indicated on the Contract Documents include, but are not limited to the following:
1. Phasing
 2. Existing site conditions
 3. Alternates
 4. Allowances
 5. Miscellaneous Steel associated with each Contract Work.
 6. Firestopping
 7. Contract No.1 GC is responsible for Coordinating and Facilitating Weekly and Daily Cleanup with other Primes (All Contractors are responsible for their final cleanup.)
- C. Prime Contract Work: Each Prime Contract can be summarized as follows:
1. The **CONTRACT for GENERAL CONSTRUCTION (Contract No. 1)** includes Architectural, Civil and Structural, plus other construction operations traditionally recognized as General Construction. General Construction Contractor is responsible to coordinate all primes tasks. It also includes administrative and coordination responsibilities. Work under this prime Contract includes, but is not limited to, the following:

**DIVISION 00 BIDDING AND CONTRACT REQUIREMENTS
& 01 GENERAL REQUIREMENTS**

ALL OF DIVISION 00 & 01

DIVISION 02 - EXISTING CONDITIONS
NOT USED

DIVISION 03 - CONCRETE

033000 CAST-IN-PLACE CONCRETE
(Inclusive of All interior and exterior Housekeeping Pads for all Prime Contractors)

DIVISION 04 – MASONRY

042000 UNIT MASONRY
044100 STONE MASONRY VENEER
047200 CAST STONE

DIVISION 05 - METALS

051200 STRUCTURAL STEEL FRAMING
053100 STEEL DECKING

054000 COLD-FORMED METAL FRAMING
055000 METAL FABRICATIONS

DIVISION 06 - WOOD, PLASTICS, AND COMPOSITES

060001 MILLWORK SCHEDULE
061053 MISCELLANEOUS ROUGH CARPENTRY
061643 GYPSUM SHEATHING
064020 INTERIOR ARCHITECTURAL WOODWORK
066116 SOLID SURFACE MATERIAL FABRICATIONS

DIVISION 07 - THERMAL AND MOISTURE PROTECTION

071326 SELF-ADHERING SHEET WATERPROOFING
072100 THERMAL INSULATION
072419 WATER-DRAINAGE EXTERIOR INSULATION AND FINISH SYSTEM
(EIFS)
072726 FLUID-APPLIED MEMBRANE AIR BARRIERS
074213.53 COMPOSITE METAL WALL AND SOFFIT PANELS
075323 ETHYLENE-PROPYLENE-DIENE-MONOMER (EPDM) ROOFING
076200 SHEET METAL FLASHING, FABRICATIONS AND TRIM
076223 SHEET METAL SIDING
077200 ROOF ACCESSORIES
077273 VEGETATED ROOF SYSTEMS
078100 APPLIED FIREPROOFING
078123 INTUMESCENT MASTIC FIREPROOFING
078413 PENETRATION FIRESTOPPING
078446 FIRE-RESISTIVE JOINT SYSTEMS
079200 JOINT SEALANTS
079500 EXPANSION CONTROL

DIVISION 08- OPENINGS

081113 HOLLOW METAL DOORS AND FRAMES
081416 FLUSH WOOD DOORS
082250 POLYESTER FACED DOORS AND ALUMINUM FRAMING
083113 ACCESS DOORS AND FRAMES
083326 OVERHEAD COILING DOORS
083329 OVERHEAD COILING GRILLES
083450 ELEVATOR DOOR SMOKE CONTAINMENT SYSTEM
084113 ALUMINUM ENTRANCES AND STOREFRONTS
084133 FOLDING GLASS STOREFRONTS
084413 GLAZED ALUMINUM CURTAIN WALLS
085656 TRANSACTION WINDOWS
086200 UNIT SKYLIGHTS
086300 METAL-FRAMED SKYLIGHTS
087100 DOOR HARDWARE
088000 GLAZING
089000 LOUVERS AND VENTS

DIVISION 09 - FINISHES

092116.23	GYPSUM BOARD SHAFT WALL ASSEMBLIES
092216	NON-STRUCTURAL METAL FRAMING
092800	GLASS-REINFORCED GYPSUM FABRICATIONS
092900	GYPSUM BOARD
093100	CERAMIC TILING
095113	ACOUSTICAL PANEL CEILINGS
095116	ACOUSTICAL BOARD CEILING PANELS
095429	WOOD PANEL ACOUSTICAL CEILING SYSTEMS
096466	WOOD ATHLETIC FLOORING
096500	RESILIENT FLOORING AND ACCESSORIES
096623	RESINOUS MATRIX TERRAZZO FLOORING
096813	TILE CARPETING
097750	FIBERGLASS REINFORCED PLASTIC PANELS
098413	ACOUSTICAL WALL PANELS
099100	PAINTING

DIVISION 10 – SPECIALTIES

101000	VISUAL DISPLAY SURFACES
101200	DISPLAY CASES
101400	SIGNAGE
102113	TOILET COMPARTMENTS
102226	OPERABLE PARTITIONS
102800	TOILET AND BATH ACCESSORIES
102900	MEDICAL ACCESSORIES
105113	METAL LOCKERS
105200	FIRE PROTECTION SPECIALTIES
105213	AUTOMATED EXTERNAL DEFIBRILLATOR (AED) SPECIALTIES
105316	CANOPIES

DIVISION 11 – EQUIPMENT

110633	STAGE CURTAINS AND RIGGING
111319	STATIONARY LOADING DOCK EQUIPMENT
113100	RESIDENTIAL APPLIANCES
114000	FOOD SERVICE EQUIPMENT
114900	GYMNASIUM EQUIPMENT
115213	PROJECTION SCREENS
116843	SCOREBOARDS AND ACCESSORIES

DIVISION 12 – FURNISHINGS

120001	CASEWORK SCHEDULE
122413	ROLLER WINDOW SHADES

123553.19	WOOD LABORATORY CASEWORK
123559	INSTITUTIONAL CASEWORK
123661	SIMULATED STONE COUNTERTOPS
124813	ENTRANCE FLOOR MATS AND FRAMES
126600	TELESCOPING STANDS

DIVISION 13 – SPECIAL CONSTRUCTION

NOT USED

DIVISION 14 – CONYEYING SYSTEMS

142100	ELECTRIC TRACTION ELEVATOR
144200	WHEELCHAIR LIFTS

DIVISION 15 – 21

NOT USED

DIVISION 31 – EARTHWORK

311000	SITE CLEARING
312000	EARTH MOVING
312316.26	ROCK REMOVAL
312319	DEWATERING
312333	TRENCHING AND BACKFILLING
312500	EROSION AND SEDIMENT CONTROL
315000	EXCAVATION SUPPORT AND PROTECTION

DIVISION 32 - EXTERIOR IMPROVEMENTS

321216	ASPHALT PAVING
321816	PLAYGROUND SURFACING
323113	CHAIN LINK FENCE
329200	TURFS AND GRASSES

DIVISION 33 – UTILITIES

331400	WATER UTILITY TRANSMISSION & DISTRIBUTION
333000	SANITARY SEWERAGE
334100	STORM UTILITY DRAIN PIPING

2. The **PLUMBING & FIRE PROTCTION CONTRACT (No. 2)** includes plumbing equipment, accessories and piping systems. Work under this prime Contract includes, but is not limited to, the following:

DIVISION 00 BIDDING AND CONTRACT REQUIREMENTS
& 01 GENERAL REQUIREMENTS

ALL OF DIVISION 00 & 01

DIVISION 02 - EXISTING CONDITIONS

NOT USED

DIVISION 07 - THERMAL AND MOISTURE PROTECTION

078413 PENETRATION FIRESTOPPING
079200 JOINT SEALANTS

DIVISION 08 – OPENINGS

083113 ACCESS DOORS AND FRAMES

DIVISION 11 – EQUIPMENT

114000 FOOD SERVICE EQUIPMENT
Kitchen and Food Service Equipment, Shop Drawings and Cut Sheets,
Coordination items as related to Plumbing work associated with food
service equipment installation.

DIVISION 15 – 21

NOT USED

DIVISION 22 – PLUMBING

220100 GENERAL CONDITIONS
220125 SCOPE OF WORK
220130 WATER SUPPLY SYSTEM
220150 SANITARY, STORM AND ACID WASTE DRAINAGE SYSTEMS
220180 NEW GAS SERVICE, STREET CONNECTIONS AND ASSOCIATED WORK
220200 MAGNETICALLY COUPLED PACKAGED GAS BOOSTER SYSTEM
220300 PLUMBING FIXTURES AND EQUIPMENT
220310 BACKFLOW PREVENTERS
220320 DOMESTIC HOT WATER GAS-FIRED HEATING EQUIPMENT
220370 SPRINKLER SYSTEM
220380 AUTOMATIC FIRE PUMP-COMBINATION SYSTEM STANDPIPE AND
SPRINKLERS
220420 SUPPORTS, SLEEVES AND PLATES
220430 INSULATION
220470 TESTS AND ADJUSTMENTS
220480 TAGS, CHARTS AND IDENTIFICATION
220490 GUARANTEE

3. The **HVAC WORK CONTRACT (No.3)** includes heating, ventilation, and air conditioning system **and** the temperature control system. Work under this prime Contract includes, but is not limited to, the following:

DIVISION 00 BIDDING AND CONTRACT REQUIREMENTS
& 01 GENERAL REQUIREMENTS

ALL OF DIVISION 00 & 01

DIVISION 02 - EXISTING CONDITIONS

NOT USED

DIVISION 07 - THERMAL AND MOISTURE PROTECTION

078413 PENETRATION FIRESTOPPING
079200 JOINT SEALANTS

DIVISION 08 – OPENINGS

083113 ACCESS DOORS AND FRAMES

DIVISION 11 – EQUIPMENT

114000 FOOD SERVICE EQUIPMENT
Kitchen and Food Service Equipment, Shop Drawings and Cut Sheets,
Coordination items as related to Mechanical work associated with food
service equipment installation.

DIVISION 23 – HEATING VENTILATING & AIR CONDITIONING

230100 GENERAL CONDITIONS
230110 SCOPE OF WORK
230140 DIESEL ENGINE EXHAUST
230190 PUMPS
230195 DIESEL FUEL SYSTEM
230200 HYDRONIC SPECIALTIES
230234 INDOOR ENTHALPY WHEEL ENERGY RECOVERY UNITS
230235 INDOOR FIXED PLATE ENERGY RECOVERY UNITS
230236 PACKAGED ROOFTOP ENERGY RECOVERY UNITS
230237 PACKAGED ROOFTOP FIXED PLATE ENERGY RECOVERY UNITS
230255 VARIABLE REFRIGERANT FLOW OUTDOOR UNITS
230260 DUCTLESS SPLIT SYSTEMS
230265 VARIABLE REFRIGERANT FLOW INDOOR UNITS
230270 VRF REFRIGERANT TO WATER HEAT EXCHANGERS
230280 VARIABLE FREQUENCY DRIVES
230290 DUCT MOUNTED COILS
230300 FANS
230310 HOT WATER CABINET HEATERS
230320 HOT WATER UNIT HEATERS
230325 CEILING RADIANT PANEL HEATERS

230330	CONVECTORS
230340	FIN TUBE RADIATION
230343	AIR CURTAINS
230400	SHEETMETAL WORK AND RELATED ACCESSORIES
230405	UNDERGROUND DUCTWORK
230410	PIPING, FITTINGS, VALVES AND NOTES (HOT WATER)
230420	SUPPORTS, SLEEVES AND PLATES
230430	INSULATION AND COVERINGS
230440	DAMPERS AND MISCELLANEOUS
230460	AUTOMATIC TEMPERATURE CONTROLS
230470	TESTING, START-UP AND ADJUSTMENTS
230480	GENERAL LABELING, VALVE CHARTS AND PIPING IDENTIFICATION
230485	HVAC SYSTEMS COMMISSIONING
230490	GUARANTEE

DIVISION 26 – ELECTRICAL

260875	PACKAGED ENGINE GENERATOR SYSTEM – DIESEL INDOOR Packaged Engine Generator System – Diesel Indoor, Shop Drawings and Cut Sheets, Coordination items as related to Mechanical work associated and as required with packaged engine generator system – diesel indoor.
--------	--

4. The **ELECTRICAL CONTRACT (No. 4)** Work under this prime Contract includes, but is not limited to, the following:

DIVISION 00 BIDDING AND CONTRACT REQUIREMENTS & 01 GENERAL REQUIREMENTS

ALL OF DIVISION 00 & 01

DIVISION 02 - EXISTING CONDITIONS

NOT USED

DIVISION 07 - THERMAL AND MOISTURE PROTECTION

078413	PENETRATION FIRESTOPPING
079200	JOINT SEALANTS

DIVISION 08 – OPENINGS

083113	ACCESS DOORS AND FRAMES
--------	-------------------------

DIVISION 11 – EQUIPMENT

114000	FOOD SERVICE EQUIPMENT Kitchen and Food Service Equipment, Shop Drawings and Cut Sheets,
--------	---

Coordination items as related to Electrical work associated with food service equipment installation.

DIVISION 23 – HEATING VENTILATING & AIR CONDITIONING

- 230140 DIESEL ENGINE EXHAUST
Diesel Engine Equipment, Shop Drawings and Cut Sheets, Coordination items as related to Electrical work associated with Diesel Engine Exhaust.
- 230195 DIESEL FUEL SYSTEM
Diesel Fuel System, Shop Drawings and Cut Sheets, Coordination items as related to Electrical work associated with Diesel Fuel System.

DIVISION 26 – ELECTRICAL

- 260100 GENERAL CONDITIONS
260125 SCOPE OF WORK
260150 APPROVED MANUFACTURERS
260200 CONDUIT
260250 DUCT BANK
260300 WIRE AND CABLE
260320 OVERCURRENT PROTECTIVE DEVICES
260350 BOXES
260400 WIRING DEVICES
260425 DIGITAL LIGHTING CONTROL SYSTEM
260450 CABINETS AND ENCLOSURES
260500 SUPPORTING DEVICES
260550 GENERAL LABELING AND IDENTIFICATION
260575 INTERIOR LUMINAIRES
260580 THEATRICAL LIGHTING AND CONTROL
260585 RIGGING
260595 QUICKTOUGH FIXED SPEEDCONTROL SYSTEM
260600 DISCONNECT SWITCHES
260650 GROUNDING
260700 PANELBOARDS
260725 SWITCHBOARD
260750 ELECTRIC SERVICE
260775 SURGE PROTECTIONS DEVICES
260785 AUTOMATIC TRANSFER SWITCH
260800 FIRE ALARM SYSTEM
260810 TELECOMMUNICATIONS AND AUDIO/VIDEO CABLING SYSTEM
260820 FIBER OPTIC CABLING SYSTEM
260825 PUBLIC ADDRESS SYSTEM
260830 XR WIRELESS CLOCKS SYSTEM
260850 AUDITORIUM SOUND SYSTEM
260860 RESCUE ASSISTANCE SIGNAL SYSTEM – AUDIO/VISUAL
260875 PACKAGED ENGINE GENERATOR SYSTEM – DIESEL INDOOR
260880 PHOTOVOLTAIC SYSTEM
260890 ELECTRICAL SYSTEMS COMMISSIONING

260900 GUARANTEE

5. Definition of extent of Prime Contract work: The Contract Documents indicate the extent of each prime contract. Except where the Contract Documents contain a more Specific description, general names and terminology on the Drawings and in the Specification Sections determine which prime contract includes a specific element of the Project.
6. Local custom and trade union jurisdictional settlements do not control the scope of Work included in each prime contract. When a potential jurisdictional dispute or similar interruption of work is first identified or threatened, the affected prime contracts shall promptly negotiate a reasonable settlement to avoid or minimize the pending interruption and delays.
7. If it becomes necessary to refer to the contract documents to determine which prime Contract includes a specific element of required work, begin by referring to the prime Contracts, themselves; then, if a determination cannot be made from the prime Contracts, refer, in the following order, to the General Conditions, this section of the Specifications, followed by the other Division-1 sections and finally with the Drawings and other Sections of the Specifications.
8. If, after referring to the contract documents, it cannot be clearly determined which prime Contractor will perform a specific item of required work, then that item of work will be included as a part of the prime Contract for General Construction Work.
9. Summary of Reference: Work of the prime Contracts can be summarized by reference to the prime contracts, General Conditions, Supplementary Conditions, and Instructions to Modifications to the Contract Document issued subsequent to the initial printing of the Project Manual and referenced by any of these. It is recognized that the work of the prime Contracts is unavoidably affected or influenced by governing regulations, natural phenomenon, including weather conditions, and other forces outside the contract documents.

1.6 MISCELLANEOUS

- A. The following additional requirements for the Contractor for **GENERAL CONSTRUCTION (Contract No. 1)** include, but not limited to the following:
 1. Temporary site protection, bridging and fencing.
 2. All blocking and in walls for use by other trades. Other trades shall identify the locations of required blocking.
 3. Blocking where necessary for installation of work under the contract for general construction.
 4. Install Access Panels provided by other Prime Contractors.

5. Provide all Interior and Exterior Concrete House Keeping Pads for All Prime contractors.
6. Snow plowing/shoveling all building areas exposed to weather, including access to the staging areas and owners Field Office.
7. Steel stud framing for all walls, interior and exterior.
8. Furnish all dumpsters for building construction, for use by all trades except Plumbing, Mechanical Demolition and Electrical Light Fixtures.
9. Daily and Weekly Cleanup of the Site and building area.
10. Install access panels/doors supplied by other trades.
11. Dewatering facilities and drains as required for other prime contractor installations within the building areas.
12. Fire Protection specialties including fire extinguishers and cases.
13. Install sleeves and other materials provided by other Contracts. Coordinate location of material installation with other Contractors.
14. Protection of work after installation.
15. Fire and smoke stop.
16. Interior floor, wall and ceiling expansion joints as per the contract documents.
17. Framing for soffits, interior and exterior.
18. All Interior Architectural Woodwork
19. Damp proofing and drainage board at foundations.
20. All louvers, casework and interior millwork.
21. Legal Removal and Disposal of fill.
22. Site Stairs, and all Interior & Exterior Concrete Pads for equipment as required by, Contract No's 2-Mechanical, 3-Plumbing and 4-Electrical and Excavation and Backfill for Emergency Generator and Ductbank for 4-Electrical, walks and Retaining walls, coordinate all work with other Prime contractors.
23. Excavation and Backfill for all site electrical excavation and backfilling, inclusive of but not exclusive of the installation of the new electrical Transformer Vault/Structure and Duct Bank, to the Building. Work to be coordinated with the EC and the utility company.
24. City Permit Information as required for Scaffolding, Bridging, Sidewalk work, Storm Drainage installations, Dumpsters, curb cuts, traffic control and site access. Also City / Utility Company(s), Water, Sewer & Gas including any associated permits, notifications and inspections, as required.
25. Temporary Heat: as required to execute Exterior Masonry work, Interior work and Interior finishes, as noted in Section 01 50 00 Temporary Facilities and Controls.
26. General Contractor to produce a draft CPM Schedule with 15 days and coordinated CPM Schedule within 60 days of award and updated monthly for the duration of the project, MEP to provide their schedules to the General Contractor.
27. Weekly and Daily Cleanup of the building as work progresses in the new construction.
28. All Exterior Concrete Equipment Pads as required by other Prime Contractors, coordinate sizes and locations with other Primes.
29. Establishing and Maintaining Project Monuments for benchmarks/

elevations.

- B. The following additional requirements for the Contractor for **PLUMBING & FIRE PROTECTION (Contract No. 2)** include, but not limited to the following:
1. The Plumbing contractor shall furnish, install and connect all plumbing supply, sanitary, and storm lines inside the building and to 5' (five feet) beyond the exterior building wall, except as noted in 2 below.
 2. Supply access panels/doors to be installed in walls, floors or ceilings to Contractor for General Construction-Contract No. 1 to install.
 3. Removal of all debris.
 4. Shall furnish, install and connect all plumbing supply, sanitary as required for the owner bathroom field trailers facility and the disassembly and removal of the same at the completion of the project.
 5. Provide all excavation and backfill for trenches inside building walls.
 6. Supply access panels/doors to be installed in walls, floors or ceilings to Contractor for General Construction to install.
 7. Provide starters to Electrical Contractor, installation to be by Electrical Contractor.
 8. Protection of work after installation.
 9. Daily and Weekly Cleanup of the Site and building area.
 10. Plumbing connection to equipment furnished by any other Contract.
 11. Temporary Water: Provide temporary water service as noted in Section 01 50 00 Temporary Facilities and Controls
 12. Install fixtures waste, vent, gas, water and other items for equipment provided by other Contracts.
 13. Trades shall identify the locations of required blocking.
 14. Provide the General Contractor, within 15 days of receiving a draft schedule, a schedule with line items and various tasks broken down with start dates and duration days and provide the same on a monthly basis for the duration of the project.
- C. The following additional requirements for the Contractor for **HVAC WORK (Contract No. 3)** include, but not limited to the following:
1. Supply access panels/doors to be installed in walls, floors or ceilings to Contractor for General Construction-Contract No. 1 to install.
 2. Provide all excavation and backfill for trenches inside building walls.
 3. Provide curbing for rooftop equipment for General Contractor-Contract-1 for installation.
 4. Provide starters to Electrical Contractor, installation to be by Electrical Contractor.
 5. Protection of work after installation.
 6. Mechanical connections to equipment furnished by any other Contract.
 7. Coordination Drawings, coordinate with Plumbing Contract and Electrical Contract.
 8. Low voltage wiring for HVAC systems.
 9. Daily and Weekly Cleanup of the Site and building area.
 10. Trades shall identify the locations of required blocking.

11. Provide the General Contractor, within 15 days of receiving draft schedule, a schedule with line items and various tasks broken down with start dates and duration days and provide the same on a monthly basis for the duration of the project.
- D. The following additional requirements for the Contractor for **ELECTRICAL (Contract No. 4)** include, but not limited to the following:
1. Removal of all debris.
 2. Supply access panels/doors to be installed in walls, floors or ceilings to Contractor for General Construction to install.
 3. Provide all excavation and backfill for trenches inside building walls.
 4. Install starters supplied by other trades.
 5. Protection of work after installation.
 6. Electrical connections to equipment supplied by other Contracts.
 7. Provide all excavation and backfill for trenches inside building walls.
 8. Site lighting and main electric power.
 9. Daily and Weekly Cleanup of the Site and building area.
 10. Temporary Electric: Provide Temporary Electrical service and lighting for the project as noted in Section 01 50 00 Temporary Facilities and Controls
 11. Trades shall identify the locations of required blocking.
 12. Coordinate with Con Edison all elements, inclusive of but not exclusive of the installation of the new electrical Transformer's, Vault/Structure and Duct Bank, to the Building. Excavation and backfill work to be coordinated with the GC. Installation to be coordinated as per Con Edison requirements and associated permits and inspections as required by the Con Edison.
 13. Provide Power to the Owner/Architects/CM's Field Office and Bathroom Field Trailer Facility and disassemble and removal of the same at the completion of the project.
 14. Provide the General Contractor, within 15 days of receiving a draft schedule, a schedule with line items and various tasks broken down with start dates and duration days and provide the same on a monthly basis for the duration of the project.
- E. Temporary service shall be provided as follows:
1. Temporary power and lighting for building and site, by the **Electrical Contractor-Contract No. 4.**, including Owners, Architect and CM Trailers/Field Offices. Electric consumption to be paid by the Owner, Temporary electrical service to be available 24 hours/day, 7days/week and paid for by the owner.
 2. Temporary Heat by the Contractor for General Construction-Contract No. 1 including temporary weather tight enclosures at all openings to maintain heat and provide heat for temperature sensitive work activities and material installations and storage, this includes but not limited to cold weather protection for masonry and concrete construction activities. Assume the building is not closed in, shrink wrap may be required. From 10/15/22 to

4/15/23 for the duration of the project. Refer to Temporary Facilities and Controls 01 50 00 for additional information.

The **Contractor for General Construction – Contract No. 1** shall provide and maintain temporary heat for the entire building every floor commencing on 10/15/2022 to 4/15/2023. The installation shall include but not limited to all equipment for a complete system, maintenance of the system for the duration required, fuel for operation of the temporary heating equipment, monitoring of the system. The Temporary Heat must maintain a minimum of 50+ degrees 24 hours a day, 7 days a week. The Contractor shall provide separate line items on the Schedule of Values showing the following items; set up of equipment and initial startup, operation and maintenance of the system for the duration noted, fuel, removal. Upon request from the Owner, Architect or Construction Manager, the bidder shall provide equipment cuts of the proposed system during the bid qualification and be prepared to explain how the system will be installed and maintained.”

3. Temporary sanitary facilities by **Contractor for General Construction-Contract No. 1**. Minimum one toilet unit per 10 workers and separate unit for women with lock as required.
4. Temporary water by **Plumbing & Fire Protection Contractor Contract No. 2**.
5. Snow plowing/shoveling all building areas exposed to weather, inclusive of the Staging Area, temporary parking areas and access to the Owners Trailer/Field Office by **Contractor for General Construction-Contract No. 1**.
6. Project identification and safety signs by **Contractor for General Construction-Contract No. 1**.
7. Each Contract is responsible for their temporary offices, storage trailers, electric hook-up and phone service.

1.7 WORK SCHEDULES

A. All work: done in accordance with a predetermined detailed Work Schedule agreed upon by Owner and Contractors. Each Prime Contractor shall submit a detailed Work Schedule to the Contractor for General Construction, within 15 days after receiving a draft schedule from Contractor for General Construction. Schedule shall include all milestone and other significant dates. Contractor for General Construction shall combine all into a CPM schedule within 30 days of award and update monthly for the duration of the project and updated monthly, all primes to sign off on final CPM Schedule.

1. Construction Schedule shall be computer generated, in CPM format and in an additional format as approved by the Architect and Owner. The Construction

Schedule must be provided in a schedule program, that can be used by CM and Architect and pdf. Work Schedule shall be revised monthly during the Course of the Work. The latest revised Work Schedule shall be submitted each month with the Application for Payment.

- B. General Contractor shall coordinate work with the Owner and other Contractors at the site, and all of their personnel and/or subcontractors.
- C. Locations of trailers, storage areas, parking areas, and staging areas shall be coordinated with the Owner, Construction Manager and Architect.
- D. It will be the responsibility of the Contractor to carefully interface all construction operations until they reach their final completion, and so the Owner's programs and services can be carried on without interruptions so that a smooth flow of all operations by all involved trades will be achieved within the allotted time.

1.8 ACCESS TO THE SITE

- A. Driveways and Entrances: Keep driveways and entrances serving the premises clear and available to the Owner, the Owner's employees, and emergency vehicles at all times. Do not use these areas for parking or storage of materials. Schedule deliveries to minimize space and time requirements for storage of materials and equipment on-site.

1.9 CODES APPLICABLE

- A. Construction will be governed by: New York State Uniform Fire Prevention and Building Code, current applicable edition, and its referenced codes and standards. State Education Department Manual for Planning Standards. Other applicable laws and regulations, including Municipal Regulations, Health Codes and local Noise Ordinances. City of Yonkers for off property construction, including but not limited to Crane Placement, Sidewalk Closing, Sidewalk Bridging, Street Crossings, and Waste Container locations.

1.10 PREPARATION OF SITE

- A. Site drawings indicate existing grade elevations, final grade elevations, and locations of work on the property.
- B. Contractor agrees to accept site as indicated and to remove Encumbrances, which interfere with proper fulfillment of his work without change in Contract Sum.
- C. All Work as noted inside or outside of Contract Limit Lines shall be performed by Contractor as part of Contract Work.

1.11 CONTRACTOR'S USE OF PREMISES

- A. Confirm Operations at the Site to Areas and Methods Permitted by:

1. Laws.
 2. Ordinances.
 3. Permits.
 4. Contract Documents.
 5. Owner's regulations.
- B. General: During the construction period the Contractor's shall have full use of the premises for construction operations. The Contractor's use of the premises is limited only by the Owner's right to perform construction operations with its own forces or to employ separate contractors on portions of the project.
- C. Confine operations to areas within Contract limits indicated. Portions of the site beyond areas in which construction operations are indicated are not to be disturbed.
- D. Do not unreasonable encumber site with materials or equipment.
- E. Do not load structure(s) with weight that will endanger structure.
- F. Each Subcontractor is responsible for protection and safekeeping of his materials, products and equipment stored on the premises of incorporated into the construction, until his contract is complete and accepted by the Owner.
- G. Site Access: Keep driveways and entrances serving the premises clear and available to the Owner, the Owner's employees, and emergency vehicles at all times. Do not use these areas for parking or storage of materials. Schedule deliveries to minimize space and time requirements for storage of materials and equipment on-site.
- H. Move at the Contractor's/Subcontractor's cost any stored materials, products or equipment which interfere with operations of Owner or others.
- I. Special Owner Requirements:
1. Partial Owner Occupancy: The Owner reserves the right to occupy and to place and install equipment in completed areas of the building, prior to Substantial Completion provided that such occupancy does not interfere with completion of Work. Such placing of equipment and partial occupancy shall not constitute acceptance of the total Work.
 2. All activities required on the site for completion of the work shall be accomplished within the Contract limit lines as indicated on the Drawings.

1.12 LINE AND LEVELS

- A. Drawings indicate location of the Work.

- B. Contractor shall layout all Work prior to construction and will be held responsible for its accuracy. Layout approval by Owner and Architect is required prior to construction.
- C. Owner shall provide Survey for the contractors use in determining and establishing: Datums, Property Lines & Benchmarks at convenient locations, which will remain throughout Work, for convenience and constant reference for use of all Contractors.
- D. Each Contractor is responsible for their own survey(s) and layout.

1.13 TIME FOR COMPLETION

- A. It shall be understood and mutually agreed that the time for Substantial Completion is an essential condition of this Contract.
- B. Contractor agrees that Work shall be prosecuted diligently and uninterruptedly at such rate as will insure Substantial Completion of all Work and Certificates of Occupancy on or before the date stated in the Contract.
- C. Its is expressly understood and agreed by Contractor and Owner that the time for Substantial Completion and Certificates of Occupancy are reasonable, taking into consideration average Climatic range, restrictions concerning use of the site, and Other conditions prevailing.
- D. Contractor shall schedule the Work accordingly.

1.14 EXAMINATION OF SURFACES TO BE COVERED

- A. Prior to application of materials included in the various Sections, the installer, the manufacturer's representative, and the Contractor shall together examine the building and surfaces upon which materials are to be supplied.
- B. The installer and the manufacturer's representative shall accept all surfaces and conditions affecting proper installation of their materials. The installer shall not proceed with the work until all conditions and surfaces not satisfactory to him.
- C. The Contractor shall do all work necessary to correct unsatisfactory conditions and surfaces not specifically included as work of the subcontractor.
- D. The subcontractor shall furnish to the Contractor for submission to the Architect 2 copies of his statement, countersigned by the manufacturer or his appointed representative that the entire installation has been made by correct techniques over properly prepared surfaces and under proper job conditions.

1.15 FIRE SAFETY REQUIREMENTS

- A. The Contractor shall conform to the following mandatory Requirements during the course of the work:

1. Construction related debris shall be cleaned out of the Building at the end of each working day.
2. No combustible materials shall be stored neither within the building, nor on the school grounds unless as directed.

PART 2 – PRODUCTS (Not Used)

PART 3 – EXECUTION (Not Used)

End of this Section 01 10 10 MULTIPLE CONTRACT SUMMARY

SECTION 011020 - MILESTONE SCHEDULE

PART 1 – GENERAL

1.1 MASTER SCHEDULE

The following milestone schedule serves as a basis for bidding. A Master Schedule will be developed at a general meeting of all successful bidders within 15 days of Award the Contracts. This Master Schedule will incorporate the milestones listed below.

1.2 SUBSTANTIAL COMPLETION & MILESTONE DATES

- | | |
|--|--|
| A. Award Contracts on or about | January 5, 2022 |
| B. Project Commencement | Date of Award of Contracts |
| C. Construction Schedule | |
| 1. General Construction Contractor Issues Draft Schedule | Within 15 days after Contract Award |
| 2. MEP and Other Primes to provide draft for their Work Activities and Durations days | 10 days after receipt of Draft Schedule from General Construction Contractor |
| 3. Final Draft Construction Schedule provided by General Construction Contractor | 15 days after receipt of schedule from MEP and other Prime Contractors |
| 4. Final Construction Schedule agreed to By All Prime Contracts | 15 days after receipt of schedule from General Construction Contractor |
| D. Submittals | |
| 1. Submittal Schedule-Contractor to Identify and Prioritize all Long Lead Items On the Submittal Schedule. | 21 Days after contract Award |
| 2. Submittals Complete | 90 Days after Contract |
| E. Substantial Completion Date | August 15, 2023 |

F. Anticipated Construction

Work	Start Construction	Substantial Completion
All Work	On or about January 30, 2022	August 15, 2023
	Punchlist-Completion date	September 30, 2023

G. Final Close-out of all Contract

a. Final Close-out of Contract

- i. Final close out of all contracts shall be within 45 days of the substantial completion dates established above. All work including, but not limited to punch lists, project closeout, testing, balancing, owner's operation, warranties, etc. shall be complete.
- ii. All work required by the Construction Manager to execute final closeout of contracts after dates noted established above, if determined to be caused by contractor, shall result in payment to the Construction Manager in the form of a change order deduct to the base contract.

H. Coordination of Move-In

It is the intent of the School District to begin move-in of furnishings, fixtures and equipment prior to the dates of substantial completion as outlined above. The Contractor shall work in harmony with the School District to facilitate such move-ins for beneficial use and occupancy.

I. Hours Site will be open

Weekdays: Monday – Friday, Weekends: Saturday and Sunday

The site is open Weekdays 7:00am to 3:30pm on major non-national holiday (Regular Working Hours). The site can be opened upon request any time other than Regular Working. (Non-Regular Working Hours) Contractor will be responsible to pay the hourly rate for a construction Manager to be onsite during any Non-Regular Working Hours. Contractor to request Site 48 hours prior to date to be open for request to be considered. Contractor must abide by all local noise ordinances and regulations and notify Construction Manager accordingly, prior to scheduling. The Contractor requesting 2nd shift/weekend work to include in their bid the cost of the on-site construction manager, Rates are as follows:

Construction Manager-2022-\$175.00/Hr. and for 2023-\$180.50/Hr.

END OF MILESTONE SCHEDULE

SECTION 011500 - SPECIAL PROJECT REQUIREMENTS

Excerpts from 8 NYCRR Section 155.5 as they address "General Safety and Security Standards for Construction Projects".

STATEMENT OF PURPOSE: "The occupied portion of any school building shall always comply with the minimum requirements necessary to maintain a certificate of occupancy"

1.1 GENERAL

- A. Requirements set forth herein are in addition to and shall be considered as complementary to the Conditions of the Contract and the balance of Division #1 and Technical Specifications.
- B. All Contractors, Subcontractors, Sub-subcontractors, Vendors and the like shall be required to familiarize themselves with said provisions.
- C. All contractors, subcontractors, Sub-subcontractors, vendors and the like shall monitor their workers and require that they adhere to the following safety provisions during all construction and maintenance activities for the duration of the project.

1.2 REQUIREMENTS INCLUDED IN THIS SECTION AS APPLICABLE TO THE PARTICULAR PROJECT SCOPE OF WORK

- A. Safe and Secure Storage of Construction Materials
- B. Fencing – Project; Material storage areas; Container/Refuse areas
- C. Gates – Manned during working hours; locked and secure off hours.
- D. Sidewalk bridges, security barriers, etc. reference "Exterior Renovations"
- E. Worker identification system
- F. Temporary partitions – separation of construction areas from occupied spaces; construction, materials, inspection and maintenance.
- G. Worker access both horizontal and vertical in occupied buildings
- H. Debris removal.
- I. Ventilation of work spaces
- J. Exiting
- K. Fire and hazard prevention
- L. No Smoking
- M. Fire extinguishers
- N. Temporary sprinklers (if any)
- O. Smoke detectors (temporary)
- P. Fire watch and maintenance of existing fire alarm systems
- Q. Storage of gas and welding equipment
- R. Noise abatement procedures
- S. Construction fume controls
- T. Off-Gassing/bake out procedures
- U. Material Safety Data Sheet log
- V. Asbestos Code Rule 56
- W. Asbestos TEM
- X. Lead Abatement/Lead paint
- Y. Indoor Air Quality

1.3 SAFE AND SECURE STORAGE OF CONSTRUCTION MATERIALS – Coordinate with Sections 015000 and 016100 each as included with these documents.

- A. Materials stored on the Site shall be neatly arranged and protected, and shall be stored in an orderly fashion in locations that shall not interfere with the progress of the Work.

NOTE: If approval is given to store materials in any part of the building area, they shall be so stored as to cause no overloading of the structure.

1.4 FENCING – PROJECT; MATERIAL STORAGE AREAS; CONTAINER/REFUSE AREAS – Coordinate with Section 015000

- A. Barrier fencing constructed as outlined in Section 015000 shall be provided surrounding all work areas, material storage locations and around dumpsters and/or chutes when involved with demolition/removal operations.
- B. Fencing shall be maintained in good sound condition throughout the entire course of construction by the Owner’s Representative and/or Contractor and removed only when directed by the Architect and/or Owner’s Representative.

1.5 GATES

- A. Gates in construction fencing shall be of construction outlined in Section 015000 and shall be under either the Owner’s Representative or Contractors’ supervision throughout the work day and shall be secured in a locked condition at the close of any single business day and on all non work days. Gates shall be manned at all times work is in progress.

1.6 SIDEWALK BRIDGES, SECURITY BARRIERS, ETC. REFERENCE “EXTERIOR RENOVATIONS”

- A. As applicable to the project involved, provide overhead protective devices for the work consisting of tubular framed scaffold bridges, joist trusses and solid decking. Provide guard rails, lights and warning signs. Scaffolding, Sidewalk bridges, security barriers, etc must be designed by a Professional Engineer registered to practice in New York State; signed and sealed drawings must be submitted for review.

1.7 WORKER IDENTIFICATION SYSTEM – Coordinate with Section 011000, Article 1.01.

- A. All Contractors' employees shall use a single means of access and egress, except in the case of emergency, to be designated by the General Contractor.
- B. The Contractor shall, for all work covered under the Contract, establish a security control system for personnel and material involved with the work herein.
- C. The control system shall include photo identification badges and the like so as to insure against unauthorized entry to the site and resultant entry to the building proper.

1.8 TEMPORARY PARTITIONS – SEPARATION OF CONSTRUCTION AREAS FROM OCCUPIED SPACES; CONSTRUCTION, MATERIALS, INSPECTION AND MAINTENANCE – Coordinate with Section 015000 as applicable to project type.

- A. Provide temporary partitions from floors to underside of structure above, in sash and any other openings created by new construction, additions and alterations.
- B. **Such partitions shall be constructed dust-tight using steel studs and acoustically and/or thermally insulated, Level 1 taped fire rated gypsum board as specified in Section 092900.**
- C. Locate enclosures as directed by the Architect and/or as shown on the drawings.

- D. In addition to partitions and closures, provide tight fitting filters over all return air grilles and/or open ducts in order to properly protect central air handling equipment.
 - E. Take all necessary precautions to avoid unnecessary dust spreading to adjoining rooms and spaces.
 - F. Keep all doors to spaces closed and provide positive seals around cracks, frames, doors and other openings within work areas.
 - G. WHERE EXTERIOR CLOSURES ARE REQUIRED, INSULATE SAME TO MAINTAIN A TEMPERATURE OF SIXTY-FIVE (65) DEGREES F. WITHIN THE PLANT WITHOUT THE USE OF SPECIAL HEATING EQUIPMENT.
 - H. All temporary enclosures/partitions/containment barriers shall be periodically inspected and maintained in good repair so as to prevent exposure to dust and contaminants outside the work and/or containment areas.
- 1.9 WORKER ACCESS BOTH HORIZONTAL AND VERTICAL IN OCCUPIED BUILDINGS
- A. A specific stairwell and/or elevator shall be assigned for construction worker use during work hours. Workers may not use corridors, stairs or elevators designated for students or school staff.
- 1.10 DEBRIS REMOVAL – Coordinate with Sections 015000, 017700 and 024119/20.
- A. Large amounts of debris must be removed by use of enclosed chutes or similar systems. There shall be no movement of debris through corridors of occupied spaces of the building. No materials shall be dropped or thrown outside the walls of the building.
 - B. All occupied parts of the building or buildings affected by renovation activity shall be cleaned at the close of each work day.
 - C. School buildings occupied during any construction period shall maintain required health, safety and educational capabilities at all times that classes are in session.
- 1.11 VENTILATION OF WORK SPACES
- A. The General Contractor shall provide indoor air quality management as follows:
 - 1. Provide an exhaust air system for the project indoor areas which could produce fumes, VOC's off-gasses, gasses, dusts, mists, or other emissions both during construction activities **and** during required curing periods, coordinate with manufacturer's requirements for all materials used.
 - 2. Exhaust air system for the project areas which could produce emissions listed in Paragraph 1 shall be utilized. Work area exhaust shall terminate at the building exterior.
 - 3. Provide temporary partitions and air seals to prevent the migration of airborne contaminants from unoccupied areas to occupied areas when applicable.
 - 4. Quality assurance:
 - a. Maintain a negative pressure between the work area and the space surrounding the work area.
 - b. Before start of work, submit a design for the exhaust air system. Do not begin work until approval of the Construction Manager is obtained. The design shall include, but not be limited to:
 - 1. The number of machines required.
 - 2. Location of the machines in the work space.
 - 3. Description of the methods used to test air flow and pressure differential.

5. System operation:
a. A sufficient quantity of exhaust fans in existing window openings or other approved locations shall be operated in accordance with the following standards:

Provide one work place air change every 15 minutes.

To calculate total air flow requirements:

$$\frac{\text{TOTAL FT}^3\text{/3MIN} - \text{VOLUME OF WORK AREA (IN FT}^3\text{)}}{15 \text{ MINUTES}}$$

To calculate the number of units needed for the work area.

$$\frac{\text{NUMBER OF UNITS NEEDED} - \text{TOTAL FT}^3\text{/MIN}}{(\text{CAPACITY OF UNIT IN FT}^3\text{/MIN})}$$

- b. **Exhaust air system shall operate for a minimum of 72 hours after work is completed, or until all materials have cured sufficiently as to stop out gassing of fumes or odors and area has been ventilated to remove all detectable traces of odors and fumes.**
c. Maintain 25 feet clearance from all temporary exhaust outlets to all active building outdoor air intakes.

6. **During reroofing operations, air intakes shall be "shut-down" or made safe in other approved manners.**

- B. The HVAC Specialty Contractor is to be completely responsible for maintaining all required ventilation in the occupied areas of the building during construction as follows:

1. Prior to construction, the HVAC Specialty contractor will examine the existing ductwork in the occupied areas of the building.
2. The layout of existing ductwork is shown, to the extent that it was originally documented, on the HVAC drawings.
3. The HVAC Specialty contractor will reroute, disconnect or cap any duct, which because of its proximity to the construction area, may carry contaminants from the construction area to the occupied area.
4. **This alteration of the existing ventilation system must prevent contaminants from entering the occupied areas, but must not prevent the maintenance of necessary ventilation in the occupied area.**

Additionally, as the HVAC Specialty contractor provides and connects new ductwork it will continue to evaluate the effect of such ducts and connections on contaminant migration. It will reroute, disconnect or cap this ductwork as needed to prevent contaminants from the construction area from entering the occupied section of the building.

At each point in the construction where such evaluation and rerouting, disconnecting or capping is required, the HVAC Specialty contractor will confer with the Architect and Construction Manager (as appropriate) in determining its course of action and will obtain the Architect's approval prior to executing this work."

1.12 EXITING

- A. At all times, the General Contractor is responsible for maintenance of safety and egress requirements from work areas.

NOTE: All legal forms of egress must be maintained at all times.

- B. Provide temporary exit passage system(s) with guard and hand rails and ramps and such other measures indicated on the drawings and as specified.

1.13 FIRE AND HAZARD PREVENTION – See Section 015000 for requirements for fire watches, storage and maintenance of welding gasses and temporary heating and the like.

1.14 NO SMOKING – No smoking is permitted on the grounds or within the construction area of any project.

1.15 FIRE EXTINGUISHERS – Fire extinguishers shall be provided within the work area and shall be monitored on a scheduled maintenance basis and so tagged to indicate same.

1.16 TEMPORARY SPRINKLERS (IF ANY) – See Section 015000 for applicable text and requirements.

1.17 SMOKE DETECTORS – The Electrical contractor shall provide a temporary battery powered smoke detection system for all areas under construction.

1.18 FIRE WATCH AND MAINTENANCE OF EXISTING FIRE ALARM SYSTEMS – See Sections 01 35 16 and 01 50 00

- A. All Contractors shall comply with the safety provisions of the National Fire Protection Association's "National Fire Codes" pertaining to the work and, particularly, in connection with any cutting or welding performed as part of the work.
- B. During welding or cutting operations, a contractor's man shall act as a fire watcher. The fire watcher shall have proper eye protection and suitable fire fighting equipment including fire extinguisher (bearing current inspection Certificate), protective gloves and any other equipment deemed necessary.
- C. The Electrical Specialty Contractor will provide for and maintain the proper operation of fire alarm and smoke detection systems in all areas throughout the course of the project. The Electrical Specialty Contractor will provide all labor and material required to accomplish this in occupied areas of the school buildings and in areas under construction.

1.19 STORAGE OF GAS AND WELDING EQUIPMENT – See Section 015000 for specific requirements and controls.

1.20 NOISE ABATEMENT PROCEDURES

- A. Develop and maintain a noise abatement program and enforce strict discipline over all personnel to keep noise to a minimum. Equipment and work shall not produce noise in excess of 60db in occupied areas or shall be scheduled for off hours or acoustical abatement procedures shall be taken. Noise level measurements (dba) shall be taken with a type 2 sound level meter in the occupied space in a location closest to the source of the noise.

- B. Execute construction work by methods and by use of equipment which will reduce excess noise.
 - C. Equip air compressors with silencers, and power equipment with mufflers.
 - D. As established in Section 011000, all contractors shall abide by the "no work" periods designated by the Owner.
- 1.21 CONSTRUCTION FUME CONTROLS – See Article 1.11 herein.
- 1.22 OFF-GASSING/BAKE OUT PROCEDURES – See Section 017700
- A. Heat all areas of new construction to 95 degrees for a minimum of 72 hours.
 - B. At the end of this period ventilate area with 100 percent outside air and exhaust air for a minimum of 24 hours to eliminate off gassing that occurs during bake out period.
 - C. Change all air filters upon completion.
 - D. Manufacturers shall be contacted to obtain information regarding appropriate temperatures and times needed to cure or ventilate the product during use and before safe occupancy of a space can be assured. Building materials or furnishings which "off-gas" chemical fumes, gases, or other contaminants shall be aired out in well-ventilated heated warehouse before they are brought to the project for installation or the manufacturer's recommended "off-gassing" periods must be scheduled between installation and use of the space. If the work will generate toxic gases that cannot be contained in an isolated area, the work must be done when school classes and programs are not in session. The building must be properly ventilated and the material must be given proper time to cure or "off-gas" before re-occupancy.
- 1.23 MATERIAL SAFETY DATA SHEET LOG – Coordinate with Section 013300
- A. Contractor shall maintain "MSDS" file on site, accessible to workers and otherwise in compliance with jurisdiction's "Right To Know" legislation.
 - B. The submittal of the required MSDS information shall be segregated from the required material/shop drawing/sample submittals in a separate binder and not commingled with the technical submittals, failure to so conform will be cause for rejection of any submittal.
- 1.24 ASBESTOS CODE RULE 56 AND ASBESTOS CONTAMINATED MATERIALS (ACM)
- A. Abatement projects as defined by Rule 56 shall not be performed while the building is occupied.
 - B. In the event asbestos-contaminated materials are encountered during the work Contractor shall immediately notify the Architect and/or Owner for instructions as to procedures to be taken.
 - C. All asbestos abatement projects shall comply with all applicable federal and State laws including but not limited to the New York State Department of Labor industrial code rule 56(12 NYCRR 56), and the federal Asbestos Hazard Emergency Response Act (AHERA), 40 CFR Part 763 (Code of Federal Regulations, 1998 Edition, Superintendent of Public Documents, U.S. Government Printing Office, Washington, DC 20402; 1998; available at the Office of Facilities Planning, Education Building Annex, Room 1060, State Education Department, Albany, New York 12234). Large and small asbestos projects as defined by 12 NYCRR 56 shall not be performed while the building is occupied. Minor asbestos projects defined

by 12 NYCRR 56 as an asbestos project involving the removal, disturbance, repair, encapsulation, enclosure or handling of 10 square feet or less of asbestos or asbestos material, or 25 linear feet or less of asbestos or asbestos material may be performed in unoccupied areas of an occupied building in accordance with the above referenced regulations.

1.25 LEAD ABATEMENT/LEAD PAINT

- A. In the event lead based paint is encountered during the work Contractor shall immediately notify the Architect and/or Owner for instructions as to procedures to be taken.
- B. Attention is directed to technical Section 099000 for "protocols" concerning lead paint removals and preparation.
- C. Any construction or maintenance operations which will disturb lead based paint shall be abated pursuant to protocols detailed in the "Guidelines for the Evaluation and Control of Lead-Based Paint Hazards in Housing" (June 1995; U.S. Department of Housing and Urban Development, Washington, DC 20410; available at the Office of Facilities Planning, Education Building Annex, Room 1060, State Education Department, Albany, NY 12234). All areas scheduled for construction as well as areas of flaking and peeling paint shall be tested for the presence of lead and abated or encapsulated in accordance with the above noted guidelines

End of Section

THIS PAGE INTENTIONALLY LEFT BLANK

GENERAL

1.1 RELATED DOCUMENTS

- A. Drawings and general provisions of the Contract, including General and Supplementary Conditions and other Division 01 Specification Sections, apply to this Section.

1.2 SUMMARY

- A. Certain items are specified in the Contract Documents by allowances. Allowances have been established in lieu of additional requirements and to defer selection of actual materials and equipment to a later date when additional information is available for evaluation. If necessary, additional requirements will be issued by Change Order.
- B. Types of allowances include the following:
 - 1. Allowance of \$100,000 for Remediation of Contaminated Soil.

1.3 SELECTION AND PURCHASE

- A. At the earliest practical date after award of the Contract, advise Architect of the date when implementation described by an allowance must be completed to avoid delaying the Work.
- B. At Architect's request, obtain proposals for each allowance for use in making final selections. Include recommendations that are relevant to performing the Work.

1.4 SUBMITTALS

- A. Submit proposals for purchase of products or systems included in allowances, in the form specified for Change Orders.
- B. Submit invoices or delivery slips to show actual quantities of materials delivered to or removed from the site for use in fulfillment of each allowance.
- C. Coordinate and process submittals for allowance items in same manner as for other portions of the Work.

1.5 COORDINATION

- A. Coordinate allowance items with other portions of the Work.

1.6 ALLOWANCES FOR SPECIFIC WORK ELEMENTS

- A. Use the allowance for specific work elements only as directed for the Owner's purposes and only by Field Orders/ Directives from the Architect that indicate amounts to be charged to the allowance. Overhead, profit, and Bond Premium are not an allowable cost for work completed under the allowance.

- B. Prime Contract related costs for products and equipment ordered by the Owner under the allowance for specific work elements are not part of the Contract Sum. These costs include delivery, installation, taxes (if applicable), insurance, equipment rental, and similar costs.
- C. Field Orders authorizing use of funds from the allowance for specific work elements shall include all Prime Contract related costs. One or more of the following methods, which will be specified in the written directive, shall determine the value of the Work directed under this allowance.
 - 1. By applying the applicable price or prices set forth in the Contract Documents or by applying a Unit Price agreed to by both parties.
 - 2. By estimating the fair and reasonable cost of:
 - a. Labor including all wages, required wage supplements and insurance required by law (workers' compensation, social security, disability, unemployment, etc.) paid to or on behalf of foremen, workers and other employees below the rank of Prime Contract designated representative directly employed at the site.
 - b. Materials.
 - c. Equipment, excluding hand tools.
 - 3. The Owner reserves the right to utilize these methods provided it notifies the Prime Contract of its intent to do so prior to the time the Prime Contract is properly authorized to commence performance of such work.
 - 4. Time and Materials.
- D. At Project closeout, credit unused amounts remaining in the contingency allowance to Owner by Change Order.

PART 2 - PRODUCTS (Not Used)

PART 3 - EXECUTION (Not Used)

END OF SECTION 01 21 00

SECTION 012300 - ALTERNATES

PART 1 - GENERAL

1.1 SUMMARY

- A. Section includes administrative and procedural requirements for alternates.

1.2 DEFINITIONS

- A. Alternate: An amount proposed by bidders and stated on the Bid Form for certain work defined in the bidding requirements that may be added to or deducted from the base bid amount if Owner decides to accept a corresponding change either in the amount of construction to be completed or in the products, materials, equipment, systems, or installation methods described in the Contract Documents.
 - 1. Alternates described in this Section are part of the Work only if enumerated in the Agreement.
 - 2. The cost or credit for each alternate is the net addition to or deduction from the Contract Sum to incorporate alternate into the Work. No other adjustments are made to the Contract Sum.

1.3 PROCEDURES

- A. Coordination: Revise or adjust affected adjacent work as necessary to completely integrate work of the alternate into the Project.
 - 1. Include as part of each alternate, miscellaneous devices, accessory objects, and similar items incidental to or required for a complete installation whether or not indicated as part of alternate.
- B. Notification: Immediately following award of the Contract, notify each party involved, in writing, of the status of each alternate. Indicate if alternates have been accepted, rejected, or deferred for later consideration. Include a complete description of negotiated revisions to alternates.
- C. Execute accepted alternates under the same conditions as other work of the Contract.
- D. Schedule: A schedule of alternates is included at the end of this Section. Specification Sections referenced in the schedule contain requirements necessary to achieve the work described under each alternate.

PART 3 - EXECUTION

3.1 SCHEDULE OF ALTERNATES

1. Add Alternate No 1: Gym Basement Fit-Out

1-GC, 2-PC, 3-MC, 4-EC:

- a. This work consists of the interior fit-out of the basement level beneath the Gymnasium including locker rooms, offices, storage spaces, mechanical spaces, and associated circulation/corridor spaces. Work includes interior walls, flooring, ceilings, finishes, doors, fixtures, accessories, equipment (lockers, benches, etc.) and MEP systems for complete construction of the spaces as indicated on the Drawings.
- b. Base Bid work includes the complete construction of areas at and adjacent to Stairs H & G, elevator and elevator machine room, and data closet, with associated finishes, fixtures, and MEP systems. All underground / below-slab accessories, waterproofing, insulation, and equipment (plumbing piping, drainage piping, HVAC systems, utilities, and conduit). Sprinkler systems, and portions of HVAC and electrical systems shall be provided as base bid as indicated on the Drawings. Base bid shall also include all structural, civil, and MEP systems and utilities that support other portions of the new construction as required to complete base bid work.

2. Add Alternate No 2: Exterior Sunshades

1-GC:

- a. This work consists of all work required to furnish and install exterior sun shading systems as indicated on the Drawings. Systems include aluminum horizontal sunshades on the South Façade of School Building, and Stainless Steel Vertical Mesh Systems on the East Façade of School Building. Add alternates shall include all work required for complete installation of assembly including required additional accessories/support, modifications to storefronts/windows, modifications to metal/zinc paneling, and required coordination/engineering/shop drawings.

3. Add Alternate No 3: Solar Panels

1-GC, 4-EC:

- a. This work consists of all work required to furnish and install exterior solar panels as shown on the roof of the School Building. All scope of work shown on Solar Drawings PG/PE Series including but not limited to Solar Modules, Rooftop Racking, inverters, Electrical distribution, and all interconnections. Coordinated all solar panel work with General Contractor for roof protections and waterproofing all roof penetrations.

4. Add Alternate No 4: Green Roof

1-GC:

- a. This work consists of all work required to furnish and install exterior green roof assembly on the "Connecting Corridor" roof between the School and the Gymnasium as indicated on the Drawings

5. Add Alternate No 5: Stage Electrical Equipment

4-EC:

- a. This work consists of all work required to furnish and install electrical systems for stage equipment including new theatrical lighting equipment and all associated conduit, wiring and panelboard for complete operational system; and standalone sound system for Gymnasium including equipment, wiring and conduit for a complete operational system.
- b. Base bid includes conduit with drag lines from main electrical room in School Basement to the gym stage area as indicated on the Drawings.

6. Add Alternate No 6: Casework / Millwork / Gym Equipment

1-GC:

- a. This work consists of all work required to furnish and install casework and millwork Classrooms, Special Ed. Classrooms, Faculty Room, Main Office, Nurse Suite, Art Room, Science Room, Library, Maker Space, Cafeteria
 - a. Base cabinets and uppers including counters and backsplash; tall cabinets in Classrooms; Cubbies; Wall Hooks; bookcases below windows in Classrooms; Main office transaction desk, mailboxes, cabinets, etc.; Library transaction desk and bookcases, Science cabinets, counters, work stations, etc.; Built-in solid surface bench at corridor nooks (Levels 2-4); Built-in booths and counter in Cafeteria

Gymnasium equipment includes furnish and installation of basketball hoops (backstops, goals, operating equipment, etc.), volleyball equipment (nets and uprights), scoreboards, shot clocks, gymnasium wall padding, two retractable bleacher assemblies, stage curtains (main curtains, valance, travelers, boarders, etc.), motorized projection screen

- b. Base bid includes blocking in walls for casework, millwork, and equipment; School Corridor lockers and Kitchen lockers; Janitor, Storage Closet, and Data Closet wall shelving, Interior and exterior window sills/stools and aprons; Display Case.

7. Add Alternate No 7: Exterior Sidewalk around Church

13 January 2022
Conformed Specifications
SED #66-23-00-01-0-346-001
1-GC:

Yonkers Joint Schools Construction Board
Community School 35

- a. This work consists of demolition of existing sidewalk and curb on West and South sides of the existing St Denis Church, and construction of new sidewalk in its place including concrete sidewalk, underlayments/sub-base, concrete curb, and all modifications to existing adjacent areas as required.

END OF SECTION 012300

The following additions, substitutions, or clarifications are extracted from the (5) Bid Addenda issued with this project during bidding. This insert is intended to summarize addendum information relevant to this specification section. See Bid Addenda issued by the City of Yonkers for complete contract document changes.

Bid Addendum No. 4:

All substitutions must be complete or will not be considered, meaning that the Contractor shall be responsible for all interrelated items that would be affected by a proposed substitution and must be submitted as a package for consideration, including potential impacts on other Prime Contractors. For substitutions that have impact on dimensions, the Contractor shall be responsible for all related items that would be affected including any additional materials, support, or accessories required for a complete installation of the substituted item and all adjacent/related components. Contractor shall note that the color palette for this project is integral to the design intent of the building. Substitutions that result in a change of color may also require changes to adjacent or other related materials in order to meet the design intent.

SECTION 012500 - PRODUCT OPTIONS AND SUBSTITUTIONS

1.1 GENERAL

- A. Requirements set forth herein are in addition to and shall be considered as complementary to the Conditions of the Contract and the balance of Division #1 and Technical Specifications.
- B. All Contractors, Subcontractors, Sub-subcontractors, Vendors, and the like shall be required to familiarize themselves with said provisions.

1.2 REQUIREMENTS INCLUDED IN THIS SECTION

- A. Approved Equal Clause
- B. Substitution Requests
- C. Options
- D. Contractor's Representation
- E. Reimbursements

1.3 APPROVED EQUAL CLAUSE

- A. Throughout the Specifications, types of material may be specified by manufacturer's name and catalog number in order to establish standards of quality and performance and not for the purpose of limiting competition.

Inclusion by name, of more than one manufacturer or fabricator, does NOT necessarily imply acceptability of standard products of those named. All manufacturers, named or proposed, shall conform, with modification as necessary to criteria established by Contract Documents for performance, efficiency, materials and special accessories.

- B. Contractor may assume the phrase "or approved equal" except that the burden is upon the Contractor to prove such equality and to satisfy Architect that proposed substitute is equal to, or superior to, the item specified.

1.4 SUBSTITUTION REQUESTS

- A. If the Contractor elects to prove such equality, he must request the Architect's and the Owner's approval in writing for substitution of such items for the specified items, stating the differences involved with and submitting supporting data and samples, if required, to permit a fair evaluation of the proposed substitution with respect to -

- 1. Performance;
- 2. Delivery times and effect on schedules, if any;
- 3. Safety;
- 4. Function;
- 5. Appearance;
- 6. Quality and durability;
- 7. Any required license fees or royalties;
- 8. Warranty terms and conditions;

The contractor shall submit a separate request for each product, supported with complete data, with drawings and samples as are appropriate to substantiate the above.

- B. The Architect, as set forth in the Post Bid Requirements in Section 002100, will review requests for substitutions with reasonable promptness, and notify the Contractor, in writing, of the decision to accept or reject the requested substitution.

1.5 OPTIONS

- A. Where Technical Specifications permit Contractor to select optional materials, items, systems, or equipment, the selection of such options is subject to the following conditions:
1. Once an option has been selected and approved, it shall be used for the entire contract.
 2. The Contractor shall coordinate his selection with the drawings and specifications and make all necessary adjustments without additional cost to the Owner.

1.6 CONTRACTOR'S REPRESENTATION

- A. A request for a substitution constitutes a representation that the Contractor:
1. Has investigated the proposed product and determined that it is equal to or superior in all respects to that specified;
 2. Will provide the same warranties or bonds for the substitution as for the product specified;
 3. Will coordinate the installation of an accepted substitution in the work, and make such other changes in the work as may be required for installation to make the work complete in all respects;
 4. Will waive all claims for additional costs, under its responsibility, which may subsequently become apparent.
 5. **Will have coordinated installation with all affected trade contractors, specialty contractors and the like and will be responsible for any and all costs which may arise as a result of this substitution.**

1.7 REIMBURSEMENTS

- A. Whenever resubmittals of materials, equipment and accessories to be incorporated in the project are necessary due to failure of Contractors to properly coordinate submittals, the submitting Contractor shall compensate the Design Professionals for required re-reviews of said submittals in accordance with the following fee schedule:

Principal's Time	\$ 225.00 per hour
Associate's Time	\$ 155.00 per hour
Employees Time	Direct Personnel Expenses X 3.0
Engineer's Time	\$ 175.00 per hour

The charges incurred will be deducted from the ensuing requisition at the direction of the Owner.

****End of Section****

SUBSTITUTION REQUEST FORM

To:

Project:

Section	Page	Paragraph	Specified Item

THE UNDERSIGNED REQUESTS CONSIDERATION OF THE FOLLOWING SUBSTITUTION:

Attached data shall include, in a tabular format to provide a line by line comparison - product description, specifications, drawings, photographs, performance and laboratory tests and the like with applicable portions of said data clearly identified.

FURTHER, The Proposed Substitution WILL (OR WILL NOT) Affect:

- Dimensions indicated on the drawings? _____
- Wiring, piping, ductwork, or other building services indicated on the drawings? _____
- Other trades and abutting or interconnection work? _____
- Manufacturer's guarantees and warranties? _____
- The construction schedule? _____
- Maintenance and service parts locally available? _____

(NOTE - If Substitution WILL affect any item above, explain in detail.)

In addition to the above, the undersigned agrees to pay for -

1. Any and all changes to the building design, including structural, civil or electro/mechanical systems engineering (if any), detailing; and
2. Any and all additional construction costs caused by the requested substitution.

The undersigned further states that the function, appearance and quality of the Proposed Substitution are equivalent or superior to the Specified Item.

SUBMITTED:	DESIGN PROFESSIONAL'S COMMENTS	
By:	Accepted	Accepted as Noted
Firm:	Not Accepted	Received Too Late
Address:		
		By:
Date:		Date:
Telephone/Fax:		Remarks:
Approved For Subcontractor Submittal:		
By:	Contractor:	Date:

THIS PAGE INTENTIONALLY LEFT BLANK

The following additions, substitutions, or clarifications are extracted from the (5) Bid Addenda issued with this project during bidding. This insert is intended to summarize addendum information relevant to this specification section. See Bid Addenda issued by the City of Yonkers for complete contract document changes.

Bid Addendum No. 4:

Contractor(s) shall be responsible for application and initial payment of fees for all required construction-related permits, and will then be reimbursed by the Owner for permit fees. As such, the cost for permitting shall be reimbursed by way of change order and shall not be included in Contractor's bid pricing. Permitting and/or oversight by the City of Yonkers may be required for, but is not limited to, the following items: Utility work in street (water, sewer, gas, etc.) , curb cuts, site access, dumpsters, storm drainage, sidewalk work, scaffolding / bridging, and traffic control. Since this is an NYSED project, no building permit from the City of Yonkers is required.

Note: City of Yonkers DPW/Engineering fees are being waived for this Project.

The Owner will not allow Contractors to bill "Down Payment" for materials. Payment for stored materials will be considered per the terms described in the Contract Documents with the required submittals, proof of purchase, and insurances provided to the Owner.

SECTION 012900 - APPLICATIONS FOR PAYMENT

1.1 GENERAL

- A. Requirements set forth herein are in addition to and shall be considered as complementary to the Conditions of the Contract and the balance of Division #1 and Technical Specifications.
- B. This Section specifies administrative and procedural requirements governing the Contractor's Applications for Payment, and supplements provisions of Article 9, Payments and Completion, of the General Conditions of the Contract.

1.2 REQUIREMENTS INCLUDED IN THIS SECTION

- A. Schedule of Values
- B. Applications for Payment

1.3 SCHEDULE OF VALUES – Article 9.2, General Conditions and Supplements thereto.

- A. Coordination: Each prime Contractor shall coordinate preparation of its Schedule of Values for its part of the Work with preparation of the Contractors' Construction Schedule.
 - 1. Correlate line items in the Schedule of Values with other required administrative schedules and forms, including:
 - a. Contractor's Construction Schedule.
 - b. Application for Payment forms, including Continuation Sheets.
 - c. List of subcontractors.
 - d. Schedule of alternates.
 - e. Schedule of allowances
 - f. List of products.
 - g. List of principal suppliers and fabricators.
 - h. Schedule of submittals.
 - 2. Submit the Schedule of Values to the Architect at the earliest possible date but no later than seven (7) days before the date scheduled for submittal of the initial Applications for Payment.
 - 3. Subschedules: Where Work is separated into phases requiring separately phased payments, provide subschedules showing values correlated with each phase of payment.
- B. Format and Content: Use the Project Manual Table of Contents as a guide to establish the format for the Schedule of Values. Provide at least one line item for each Specification Section. For major trades with total line items exceeding \$25,000, provide a separate, back-up breakdown of each such trade with line items for identifiable units of work within such trade each of which has a value not exceeding \$25,000. Provide a computed unit price for each line total.
 - 1. Identification: Include the following Project identification on the Schedule of Values:
 - a. Project name and location.
 - b. Name of the Architect
 - c. Project number.
 - d. Contractor's name and address.
 - e. Date of submittal.
 - 2. Arrange the Schedule of Values in tabular form with separate columns to indicate the following for each item listed:
 - a. Related Specification Section or Division.

- b. Description of Work.
- c. Name of subcontractor.
- d. Name of manufacturer or fabricator.
- e. Name of supplier.
- f. Change Orders (numbers) that affect value.
- g. Dollar value.
- h. Percentage of Contract Sum to nearest one-hundredth percent, adjusted to total 100 percent.
- i. Phase Area (as applicable).

NOTE: Margins of Cost: Show line items for indirect costs and margins on actual costs only when such items are listed individually in Applications for Payment. Each item in the Schedule of Values and Applications for Payment shall be complete. Include the total cost and proportionate share of general overhead and profit margin for each item.

3. Provide a breakdown of the Contract Sum by Phase Area in sufficient detail to facilitate continued evaluation of Applications for Payment and progress reports. Coordinate with the Project Manual table of contents. Break principal subcontract amounts down into several line items.
4. Round amounts to nearest whole dollar; the total shall equal the Contract Sum.
5. Provide a separate line item in the Schedule of Values for each part of the Work where Application for Payment may include materials or equipment, purchased or fabricated and stored, but not installed. Differentiate between items stored on-site and items stored off-site. Include requirements for insurance and bonded warehousing, if required.
6. Provide separate line items on the Schedule of Values for initial cost of the materials, for each subsequent stage of completion, and for total installed value of that part of the Work.
7. Unit Price Work: Show the line-item value of unit-cost allowances, as a product of the unit multiplied by the measured quantity. Estimate quantities from the best indication in the Contract Documents.
8. Temporary facilities, clean up and other major cost items and correction of existing conditions are not direct cost of actual work-in-place may be shown either as separate line items in the Schedule of Values or distributed as general overhead expense, at the Contractor's option.
9. Project Closeout Expenses including any and all expenses involving project documentation, warranty assembly, inspection costs and fees and the like.
10. Schedule Updating: Update and resubmit the Schedule of Values prior to the next Application for Payment when Change Orders result in a change in the Contract Sum.

1.4 APPLICATIONS FOR PAYMENT - See Article 9.3 of the General Conditions and Supplements thereto.

- A. Each Application for Payment shall be consistent with previous applications and payments as certified by the Architect and paid for by the Owner. The initial Application for Payment, the Application for Payment at time of Substantial Completion and the final Application for Payment involve additional requirements.

- B. Payment-Application Times: Each progress-payment date is indicated in the Agreement. The period of construction Work covered by each Application for Payment is the period indicated in the Agreement or in absence thereof the previous month.
- C. Payment-Application Forms: Use AIA Document G702 and Continuation Sheets G703 as the form of Applications for Payment.
- D. Application Preparation: Complete every entry on the form. Include notarization and execution of person authorized to sign legal documents on behalf of the Contractor. The Architect will reject, and return, incomplete applications without action.
 - 1. Entries shall match data on the approved Schedule of Values and the Contractor's Construction Schedule. Update schedules if revisions were made.
 - 2. Include amounts of Change Orders and Construction Change Directives issued prior to the last day of the construction period covered by the application.
 - 3. Provide copies of payrolls which are signed and notarized documenting compliance with prevailing wage laws as applicable to particular project.
- E. Transmittal: Submit three (3) signed and notarized original copies of each Application for Payment to the Architect by a method ensuring receipt within 24 hours. One copy shall be complete, including waivers of lien and similar attachments, when required. Transmit each copy with a transmittal form listing attachments and recording appropriate information related to the application, in a manner acceptable to the Architect.
- F. Waivers of Mechanics Lien: With each Application for Payment, submit waivers of mechanics liens from subcontractors, sub subcontractors and suppliers for the construction period covered by the previous application.
 - 1. Submit partial waivers on each item for the amount requested, prior to deduction for retainage, on each item.
 - 2. When an application shows completion of an item, submit final or full waivers.
 - 3. The Owner reserves the right to designate which entities involved in the Work must submit waivers.

Submit final Applications for Payment with or preceded by final waivers from every entity involved with performance of the Work covered by the application who is lawfully entitled to a lien.
- 4. Waiver Forms: Submit waivers of lien on forms, and executed in a manner, acceptable to the Owner and/or as included as attachment to Section 007000.
- G. Initial Application for Payment: Administrative actions and submittals, that must precede or coincide with submittal of the first Application for Payment, shall include the following prerequisites to processing:
 - 1. List of subcontractors, approved.
 - 2. List of principal suppliers and fabricators, approved.
 - 3. Schedule of Values, approved.
 - 4. Contractor's Construction Schedule, approved.
 - 5. Schedule of principal products.
 - 6. Schedule of unit prices, approved.

7. Submittal Schedule, approved.
 8. List of Contractor's staff assignments.
 9. List of Contractor's principal consultants.
 10. Copies of building permits as applicable to project requirements.
 11. Copies of authorizations and licenses from governing authorities for performance of the Work.
 12. Initial progress report.
 13. Report of pre-construction meeting.
 14. Certificates of insurance and insurance policies.
 15. Performance and payment bonds.
 16. Data needed to acquire the Owner's insurance.
 17. Initial settlement survey and damage report, if required by particular project.
 18. Safety plan
- H. Monthly Application for Payment Administrative actions and submittals, that must precede or coincide with submittal of the periodic Application for Payment, shall include the following:
1. As-built Record documents, required documents and submittal records on site.
 2. Contractor's construction schedule, updated, with corrective action plan as applicable.
 3. Material Status Report.
 4. Stored Materials forms.
 5. Submittal Schedule and submittal status reports.
 6. RFI submittal and status log.
 7. Monthly Progress report, and Notarized Progress Report Statement from each Contractor's manager/superintendent stating that the work is on schedule, and that Contractor will meet the Substantial Completion date for the Work, and the Substantial Completion dates for every portion established under Construction Phasing Schedule Section.
- I. Application for Payment at Substantial Completion: Following issuance of the Certificate of Substantial Completion, submit an Application for Payment.
1. This application shall reflect Certificates of Partial Substantial Completion issued previous to Owner occupancy of designated portions of the Work.
 2. Administrative actions and submittals that shall precede or coincide with this application include:
 - a. Occupancy permits and similar approvals.
 - b. Warranties (guarantees) and maintenance agreements.
 - c. Test/adjust/balance records.
 - d. Maintenance instructions.
 - e. Meter readings.
 - f. Startup performance reports.
 - g. Changeover information related to Owner's occupancy, use, operation, and maintenance
 - h. Final cleaning.
 - i. Application for reduction of retainage and consent of surety.
 - j. Advice on shifting insurance coverages.
 - k. Final progress photographs.
 - l. List of incomplete Work, recognized as exceptions to Architect's Certificate of Substantial Completion.

- J. Final Payment Application: Administrative actions and submittals that must precede or coincide with submittal of the final Application for Payment include the following:
1. Completion of Project closeout requirements.
 2. Completion of items specified for completion after Substantial Completion.
 3. Ensure that unsettled claims will be settled.
 4. Ensure that incomplete Work is not accepted and will be completed without undue delay.
 5. Transmittal of required Project construction records to the Owner.
 6. Certified property survey as and/if required by project documents.
 7. Proof that taxes, fees, and similar obligations were paid.
 8. Removal of temporary facilities and services.
 9. Removal of surplus materials, rubbish, and similar elements.
 10. Change of door locks to Owner's access.
 11. Consent of Surety to final payment.

PART 2 – PRODUCTS

NOT USED

PART 3 – EXECUTION

NOT USED

****End of Section****

THIS PAGE INTENTIONALLY LEFT BLANK

PAYROLL CERTIFICATION

_____ am an officer with the title of _____
in the firm of _____ and am authorized by that firm to sign and swear, under penalty of perjury, to the validity and accuracy of the statements below.

(1) I pay or supervise the payment of laborers, workers and mechanics employed by _____ on the _____ project. During the payroll period commencing on the _____ day of _____ 20__ and ending the _____ day of _____ 20__ all laborers, workers and mechanics employed on said project were paid the wages and supplements recorded as earned on the attached payroll records. No deductions have been made either directly or indirectly from the wages and supplements other than deductions shown on the payroll records.

(2) The payroll records submitted for the above project and attached hereto are correct and complete, and the wage rates for laborers, workers, and mechanics contained therein are not less than the applicable wage rates stated in the Contract and as designated by the State Labor Department. The number of hours shown for each employee reflects the actual hours worked by that employee. The classification shown for each employee is accurate and conforms with the work he or she performed.

(3) Supplements required in the Contract that are in addition to the basic hourly wages have been or will be paid to the appropriate plans, funds or programs.

(4) Such statement so to be filed shall be verified by the oath of the Contractor that he or she has read such statement subscribed by him or her and knows the content thereof, and that the same is true of his or her own knowledge except with respect to wages and supplements owing by subcontractors which may be certified upon information and belief.

(5) All employees of this firm have submitted completed Form I-9, Employment Eligibility Verification Form which has been reviewed and signed by authorized representatives of the firm and are kept in the employees' file. Also, any and all subcontractors have certified to us that all of their employees have submitted completed Form I-9 Employment Eligibility Verification Form, which have been reviewed and signed by authorized representatives of the firm and are kept in the employees' file.

By: _____

Firm
Name _____

Title: _____

Firm
Address _____

Date: _____

Prime

Subcontractor

NOTARY

NOTARY

REQUISITION FOR PARTIAL PAYMENT - WAIVER OF LIENS

PROJECT	OWNER
GENERAL CONTRACTOR	SUBCONTRACTOR/VENDOR
CONTRACT	WORK COMPLETE
PROJECT:	CONTRACT - \$
TRADE:	CHANGE ORDERS - \$
CONTRACT - \$	TOTAL COMPLETE - \$
CHANGE ORDERS - \$	RETAINAGE (___ %) - \$
TOTAL CONTRACT - \$	LESS PRE. REQ. - \$
	THIS REQUISITION - \$

Waiver of Lien

The undersigned, upon receipt of the above requisition payment hereby releases and discharges the Owner of and from any liability or obligation in any way related to or arising out of this project up to and including the date of this document.

The undersigned further covenants and agrees that it shall not in any way claim or file a mechanic's or other lien against the premises of the above designated project, or any part thereof, or against any fund applicable thereto for any of the work, labor, materials heretofore furnished by it in connection with the improvement of said premises.

The undersigned further warrants that, in order to induce the Owner to release this partial payment, they have paid all claims for labor, material, insurance, taxes, equipment, etc., employed in the prosecution of the work above, to date of this requisition.

The undersigned hereby releases and agrees to hold the Owner harmless from any and all claims in connection with the furnishing of such labor and materials, etc., for the construction of the aforementioned project.

The undersigned further guarantees that all portions of the work furnished and/or provided by them are in accordance with the contract and that the terms of the contract with respect to these guarantees will hold for the period specified in said contract.

IN WITNESS WHEREOF, we have executed under seal this release on the date below and to be legally bound hereby:

WITNESS: _____ FIRM: _____

BY: _____ DATE: _____

CORPORATE ACKNOWLEDGEMENT

State of _____)SS.
)
County of _____

On the _____ day of _____, before me came _____ to me known and who by me being duly sworn did depose and say that he resides at _____; that he is the officer of the said corporation executing the foregoing instrument, that he knows the seal of said corporation, that the seal affixed to said instrument is such corporate seal, that it was so affixed by order of the Board of Directors of said corporation and that he signed his name thereto by like order.

Notary Public

INDIVIDUAL ACKNOWLEDGEMENT

State of _____)SS.
)
County of _____

On the _____ day of _____, before me came _____ to me known and who by me being duly sworn did depose and say that he resides at _____ that he is the individual who executed the foregoing instrument.

Notary Public

PARTNERSHIP ACKNOWLEDGEMENT

State of _____)SS.
)
County of _____

On the _____ day of _____, before me came _____ to me known and who by me being duly sworn did depose and say that he resides at _____; that he is the partner in the firm of _____ doing business under the name of _____ and that he executed the foregoing instrument on behalf of said partnership.

Notary Public

The following additions, substitutions, or clarifications are extracted from the (5) Bid Addenda issued with this project during bidding. This insert is intended to summarize addendum information relevant to this specification section. See Bid Addenda issued by the City of Yonkers for complete contract document changes.

Bid Addendum No. 2:

Each separate contract is responsible to perform their own penetration fireproofing.

Bid Addendum No. 4:

General Contractor shall be responsible for all trenching, excavation, backfill, for services/utilities as described on the Coordination Chart 013113. General Contractor shall also be responsible for site restoration and finish surface repairs at these areas. Plumbing Contractor shall provide piping and connections for water/fire service lines (incl. line for hose bib) and gas lines as shown on Drawing P206, and provide piping to five feet outside the footprint for sanitary and storm.

Refer to Coordination Chart 013113. General Contractor is responsible for traffic control for all aspects of the Project including work for other Prime Contractors.

Excavation and backfill within the building footprint is by the GC as noted on the Coordination Chart Specification Section 013113.

SECTION 013113 - PROJECT COORDINATION

1.1 GENERAL

- A. Requirements set forth herein are in addition to and shall be considered as complementary to the Conditions of the Contract and the balance of Division #1 and Technical Specifications.
- B. All Contractors, Subcontractors, Sub-subcontractors, Vendors and the like shall be required to familiarize themselves with said provisions.
- C. Definitions as apply to "Contractors" involved with the work of this Project shall be as set forth in Section 011000, Article 1.01.
- D. Please also refer to the Coordination chart attached at the end of this Section for additional information.

1.2 REQUIREMENTS INCLUDED IN THIS SECTION

- A. Coordination of Work
- B. Trade Contractor Obligations

1.3 COORDINATION OF WORK

- A. As required by the General Conditions, and restated herein, each Trade and/or Specialty Contractor or Subcontractor shall compare the architectural, structural, civil/site, mechanical, plumbing, and electrical Drawings and Specifications with those for all other trades and shall report any discrepancies between them to the Architect, thru the Construction Manager, and obtain from him written instructions for changes necessary to the work. All work shall be installed in cooperation with other trades installing interrelated work. Before installation, each Trade Contractor shall make proper provisions to avoid interference in a manner approved by the Architect. All changes required in the work caused by neglect to so advise the Architect shall be made by the offending Contractor at his own expense.
- B. Each Trade Contractor shall be responsible for exact location of anchor bolts, sleeves, inserts, supports, chases, conduits, and openings that may be required for the work.

Attention is directed to Section 013114. Coordination Drawings and Scheduling. Each Trade Contractor shall prepare layout drawings for incorporation of items to be built-in the work, pass through the work and the like in sufficient time so as not to cause any undue delay in the execution of the work.

Built-in items shall be furnished under the same Section of the Specifications as the respective items to be supported, and they shall be installed, except as otherwise specified, by the trade furnishing and installing the material in which they are to be located. The trade responsible for the installation of anchor bolts shall also ensure that they are properly installed. Chases, conduits, and openings shall be laid out in advance to permit provision in work. Sleeves and inserts shall not be used in any portion of the building, where their use would impair strength or construction features of the building. Sleeves, conduits, and inserts shall be set in forms before concrete is poured. Extra work required where anchor bolts, supports, sleeves, chase openings, conduits or inserts have been omitted or improperly placed shall be performed at expense of trade which made error or omission.

- C. Slots, chases, openings and recesses through floors, walls, ceilings and roofs as specified will be provided for the various trades in their respective materials under

general construction work, but the trade requiring them shall see that they are properly located and shall do any cutting and patching caused by the neglect to do so.

- D. Locations of pipes, ducts, electrical raceways, switches, panels, equipment, fixtures, etc. shall be adjusted to accommodate the work to interferences anticipated and encountered. Each Trade Contractor shall determine, and submit for approval, the exact route and location of each pipe, duct and electrical raceway prior to fabrication.

Approval by the Architect is required prior to any such modifications.

- E. Lines which pitch shall have the right of way over those which do not pitch.

For example, plumbing and condensate piping drains shall normally have right of way.

Lines whose elevations cannot be changed shall have the right of way over lines whose elevations can be changed.

- F. Offsets, transitions, and changes in direction in pipes, ducts and electrical raceways shall be made as required to maintain proper headroom and pitch of sloping lines whether or not indicated on the Drawings. Each Trade Contractor shall provide air vents, sanitary vents, pull boxes, etc.; as required to affect these offsets, transitions, and changes in direction.
- G. Each Trade Contractor shall install all mechanical and electrical work to permit removal (without damage to other parts) of coils, heat exchanger bundles, fan shafts and wheel, draw-out circuit breakers, filters, belt guards, sheaves and drives and all other parts requiring periodic replacement or maintenance. Each Trade Contractor shall arrange pipes, ducts, raceways, traps, starters, motors, control components, and the like, to clear the openings of swinging and overhead doors and of access panels.
- H. In all locations where subjected to public access, or in any occupied spaces, any and all piping systems servicing mechanical delivery systems which run on the face of construction shall be encased in a permanent encasement such as steel studs and drywall; steel framing, lathing and plaster; or other suitable and approved materials.
- I. AS REQUIRED BY COORDINATED SCHEDULING, The General Contractor shall provide temporary weathertight and protected openings in structure to facilitate placement of equipment.

1.4 TRADE CONTRACTOR OBLIGATIONS

- A. The Trade Contractors are required to supply all necessary supervision and coordination information to any other trades who are supplying work to accommodate the electrical and mechanical installations.
- B. Where a trade is required to install items which it does not purchase, it shall include for such items:
 - 1. The coordination of their delivery.
 - 2. Their unloading from delivery trucks driven into any designated point on the property line at grade level.
 - 3. Their safe handling and field storage up to the time of permanent placement in the project.

4. The correction of any damage, defacement, or corrosion to which they may have been subjected.
 5. Their field assembly and internal connection as may be necessary for their proper operation.
 6. Their mounting in place including the purchases and installation of all dunnage supporting members and fastenings necessary to adapt them to architectural and structural conditions unless support members are shown on structural or architectural drawings.
 7. Their connection to building systems including the purchase and installation of all terminating fittings necessary to adapt and connect them to the building systems.
- C. Items which are to be installed but not purchased as part of the work of a particular trade shall be carefully examined by this trade upon delivery to the project.

Claims that any of these have been received in such condition that their installation will require procedures beyond the reasonable scope of the work of the installing trade will be considered only if presented in writing within one week of the date of delivery to the project of the items in question.

The work of the installing trade shall include all procedures, regardless of how extensive, necessary to put into satisfactory operation, all items for which no claims have been submitted as outlined above.

****End of Section****

New Community School 35
Multiple Prime Contractor Coordination Chart

	Contract #1	Contract #2	Contract # 3	Contract #4
	General Construction (including Site Development)	Plumbing & Fire Protection	HVAC	Electrical
General Requirements	All Contracts Responsible	All Contracts Responsible	All Contracts Responsible	All Contracts Responsible
Project Scheduling	GC to facilitate Master Schedule and provide all durations and updates for GC work and monthly updates to full project schedule.	Provide durations and updates for all Plumbing & Fire Protection work. Coordinate schedule with other primes.	Provide durations and updates for all HVACwork. Coordinate schedule with other primes.	Provide durations and updates for all Electrical work. Coordinate schedule with other primes.
Trenching & Backfill for Utilities	Provide all trenching, de-watering, bedding and backfill and concrete for the entire project except as listed below. Refer to the MEP drawings for concrete housekeeping pads & other concrete required within building footprint.			
New Electric Service	Provide all trenching, de-watering, bedding and backfill outside of the building footprint.			Provide conduit / wire for new electric service from building to utility connection.
New Gas Service	Provide all trenching, de-watering, bedding and backfill outside of the building footprint.	Provide piping for all new gas piping from building to utility connection		
All other utilities	Provide all trenching, de-watering, bedding and backfill outside of the building footprint.	Provide all piping to 5 feet outside of building footprint.		
Site Electric	Excavate and backfill for all site electric.			Provide conduit / wire for new site electric / security. Wire hot box & cistern pump box.
Light Pole Bases	Excavate and backfill for all site lighting.			Provide light pole bases.
New Transformer and base				Provide utility manhole as per Con Ed. requirements.
Site improvements in old building footprint	Remove any remaining sub-surface structures as required to establish new foundations.			Provide all site electric and site lighting within Existing Building Footprint.
Trenching & Backfill for sub slab work	Provide all trenching, de-watering, bedding and backfill and concrete within the building footprint. Refer to the MEP drawings for concrete housekeeping pads & other concrete required within building footprint.	Provide all piping / systems .	Provide all ductwork and piping.	Provide all conduit / wire.
Sleeves and holes for piping / conduit	Provide all holes and openings for systems installed by this Contract and set all sleeves, embedded items and create openings required by other trades.	Provide all sleeves and embedded items including detailed horizontal and vertical dimensions to GC for installation.	Provide all sleeves and embedded items including detailed horizontal and vertical dimensions to GC for installation.	Provide all sleeves and embedded items including detailed horizontal and vertical dimensions to GC for installation.
Patching & Firestopping	Provide all patching & firestopping for work of this Contract	Provide all patching & firestopping for work of this Contract	Provide all patching & firestopping for work of this Contract	Provide all patching & firestopping for work of this Contract.
Cutting and Patching of Finished Surfaces	Provide all finish patching of openings.			
Removal of Debris	Provide all waste removal containers for the new building project for all prime contractors and dispose of all waste related to the work of this Contract	Dispose of all waste related to the work of this Contract in G.C.'s containers.	Dispose of all waste related to the work of this Contract in G.C.'s containers.	Dispose of all waste related to the work of this Contract in G.C.'s containers.
Building and Partition Layout	Provide all building and partition layout to facilitate the work of other prime contractors.			
Layout of Systems	Provide all layout for the work of this contract.	Provide all layout for the work of this contract.	Provide all layout for the work of this contract.	Provide all layout for the work of this contract.
Coordination Drawings	All Contracts Responsible	All Contracts Responsible	All Contracts Responsible	All Contracts Responsible
Cleaning During Construction	All Contracts Responsible	All Contracts Responsible	All Contracts Responsible	All Contracts Responsible
Final Cleaning	Provide final cleaning of all areas	Provide final cleaning of all fixtures, equipment and systems installed by this Contractor.	Provide final cleaning of all fixtures, equipment and systems installed by this Contractor.	Provide final cleaning of all fixtures, equipment and systems installed by this Contractor.

SECTION 013114 - COORDINATION DRAWINGS AND PROCEDURES

1.1 GENERAL

- A. Requirements set forth herein are in addition to and shall be considered as complementary to the Conditions of the Contract and the balance of Division #1 and Technical Specifications.
- B. All Contractors, Subcontractors, Sub-subcontractors, Vendors and the like shall be required to familiarize themselves with said provisions.
- C. Definitions as apply to "Contractors" involved with the work of this Project shall be as set forth in Section 01 10 00, Article 1.01.
- D. Coordination of the work shall be performed as outlined below.

1.2 REQUIREMENTS INCLUDED IN THIS SECTION

- A. Scheduling (Coordinate with Section 01 32 00)
- B. Coordination Drawings and Procedures - General Construction Work
- C. Coordination Drawings and Procedures – MEP Work
- D. Meetings
- E. Penalties

1.3 SCHEDULING

- A. Development of coordination drawings shall begin immediately upon award and shall not be dependent upon structural shop drawings; development shall be based upon structural information included on the Contract Documents.
- B. During the "final" review of the coordination drawings, the approved structural shop/fabrication drawings shall be checked and any conflicts identified. General Contractor shall coordinate and ensure structural shop drawings are processed so as to meet this requirement. Failure to prosecute same in a timely manner will be cause for implementation of penalties as outlined in 1.07 herein.
- C. Sheet metal specialty contractor or subcontractor shall provide initial drawings as indicated in Article 1.05 herein within six (6) weeks of issuance of Letter or Intent or Contract, whichever is earliest. Time to complete all drawings may vary based upon size and complexity of project. Extension to the six (6) weeks for final coordination drawings shall be determined prior to award by the Design Professional Team in consultation with the Contractors.
- D. Each subsequent contractor, as listed in 1.05.E shall complete their work within three (3) weeks of receipt of the sheet metal drawings.
- E. Progress of coordination drawings must be reported at every project meeting until accepted.

1.4 COORDINATION DRAWINGS AND PROCEDURES - GENERAL CONSTRUCTION WORK

Attention is directed to this Section for coordination drawing requirements for this project. These drawings are critical to the proper execution of the Work and failure to honor these requirements may become the basis for denial of any and all claims for either or both "time" and "money".

- A. The Contractor shall provide fully integrated building, structural, Coordination Drawings and Procedures

mechanical/electrical coordination drawings and field installation layouts for such work as directed by the Architect and/or Owner's Representative (based upon construction method) and/or required by job requirements so as to resolve tight field conditions except as modified in Paragraph 1.05 below.

- B. These composite shop drawings and field installation layouts shall be coordinated in the field among the Contractors to verify the proper relationship to the work of other trades based on field conditions and shall be checked for accuracy and approved by the Contractors before submission to the Architect for his review and concurrence and shall become the basis for more specific shop drawing submittals as required by the technical specifications.
- C. Reflected Ceiling Systems as described in Technical Sections with the "Base" drawings for ceiling work for each area composed of reflected ceiling plans with overlay of contract drawings *for* structural framing. Elevations of bottom of structural members and ceiling heights to be clearly identified.
 - 1. Section 09 29 00, Gypsum Drywall - GENERAL CONTRACTOR RESPONSIBILITY.
 - 2. Section 09 51 13; 09 51 16; 09 54 29; , Acoustical/Ceiling Treatments - GENERAL CONTRACTOR RESPONSIBILITY.

CONTRACT DRAWINGS MAY NOT BE USED; Minimum Scale - 1/4 inch = 1 foot

The reflected ceiling drawings shall then be forwarded to the next succeeding Contractor in the following order:

- 1. Sheet Metal Subcontractor.
- 2. Fire Protection (Sprinkler & Fire-Proofing) Contractor (As applicable)
- 3. HVAC Piping and Associated Control Systems.
- 4. Plumbing System.
- 5. Electrical.
- 6. General Contractor for final structural review and submission to the Architect when all internal coordination requirements have been satisfied.

1.5 COORDINATION DRAWINGS AND PROCEDURES - MECHANICAL/ELECTRICAL WORK

- A. Mechanical, Plumbing and Electrical work shall be coordinated as indicated by the following procedure. Review of coordination drawings shall not diminish responsibility under this Contract for final coordination of installation with Architectural and Structural work.

NOTE: Electronic documents (CAD files) can be used for these operations based upon agreement between all parties and in accordance with terms and conditions set for obtaining of CAD files as per attachment to Section 01 33 00.

- B. The HVAC Contractor and/or the Sheet Metal Subcontractor shall prepare a complete draft set of drawings to act as background drawings, showing structure and other information as needed for coordination. He shall show sheet metal layout thereon. Upon acceptance of these drawings, the HVAC Contractor shall prepare digital drawing files (PDF, CAD, BIM, etc.) and these will be the Coordination Drawings.
- C. ALL FIREWALLS AND SMOKE PARTITIONS MUST BE HIGHLIGHTED ON THE

SHEET METAL DRAWINGS FOR APPROPRIATE COORDINATION.

- D. The main paths of egress from main mechanical and electrical rooms must be clearly shown on the coordination drawings.
- E. Each of the below specialty trades shall add its work to these background drawings with appropriate elevations and grid dimensions using a color-coding system to be developed between trades.

Specialty trade information is required for fan rooms and mechanical rooms, horizontal exits from duct shafts, crossovers, and for spaces in and above ceilings where congestion of work may occur such as corridors, and even entire floors.

Drawings shall indicate horizontal and vertical dimensions, to avoid interference with structural framing, ceilings, partitions, and other services.

- 1. Specialty Trades
 - a. Sheet Metal Subcontractor (via the HVAC Contractor).
 - b. Fire Protection (Sprinkler & Fire-Proofing) Contractor (As applicable);
 - c. HVAC Piping and Associated Control Systems.
 - d. Plumbing Systems.
 - e. Electrical Systems.
 - f. General Contractor.
- F. Each specialty trade shall sign and date each coordination drawing. Return drawings to the HVAC Contractor, who shall route them sequentially to all specialty trades.
- G. Where conflicts occur with placement of materials of various trades, the HVAC Subcontractor will be responsible to coordinate the available space to accommodate all trades. Any resulting adjustments shall be initialed and dated by the specialty trade. The Sheet Metal Subcontractor shall then final date and sign each drawing. If he cannot resolve conflicts, the decision of the General Contractor shall be final.
- H. A Contractor who fails to promptly review and incorporate his work on the drawings shall assume full responsibility of any installation conflicts affecting his work and of any schedule ramifications.
- I. HVAC Contractor shall make copies of all coordination drawings. Fabrication shall not start until completed coordination drawings are received by the Architect/Engineer and have been reviewed.
- J. Review of coordination drawings shall not diminish responsibility under this Contract for final coordination of installation and maintenance clearances of all systems and equipment with Architectural, Structural, Mechanical, Plumbing, Electrical and other work.
- K. After Architect/Engineer Review:
 - 1. After review of coordination drawings, the method used to resolve interferences not previously identified shall be as in 1.06 "MEETINGS" below.
 - 2. All changes to reviewed coordination drawings shall be approved in writing

- by the Architect/Engineer prior to start of work in affected area.
- L. Distribution of Coordination Drawings:
1. The HVAC Contractor shall provide the following distribution of documents:
 - a. One digital version of the Coordination Drawing to each specialty trade and affected Contractor for their use.
 - b. One digital version of the Coordination Drawing to Owner.
 - c. One digital version of the coordination drawing to General Trades Contractor.
 - d. One digital version of the coordination drawing to the Construction Manager/Owners Representative as applicable to construction contracts.
- M. Coordination Drawings include but are not necessarily limited to:
1. Structure
 2. Partition/room layout.
 3. Ceiling tile and grid.
 4. Light fixtures.
 5. Access panels.
 6. Sheet metal, coils, boxes, grilles, diffusers, etc.
 7. HVAC piping and valves.
 8. Smoke and fire dampers.
 9. Soil, waste and vent piping.
 10. Water piping
 11. Roof drain piping.
 12. Major electrical conduit runs, panel boards, feeder conduit and racks of branch conduit.
 13. Above ceiling miscellaneous metal.
 14. Fire Protection Systems.
 15. Heat tracing of piping.
 16. Equipment support, anchors, guides and seismic restraints.
- N. All coordination drawings shall be delivered to the Architect at the end of the project as part of the record drawing requirements set forth in Article 3.11 of the General Conditions.
- 1.6 MEETINGS – Coordinate with Section 01 31 19
- A. Coordination meetings to resolve interferences in the work will be held at the project site under the direction of the Architect and Construction Manager.
- Representatives of each Contractor shall be present at each meeting.
- Each Contractor shall provide the necessary manpower and/or overtime to ensure that the coordination process described herein does not delay the Project Schedule.
- 1.7 PENALTIES
- A. FAILURE OF ANY INDIVIDUAL PRIME CONTRACTOR TO PARTICIPATE IN THE PREPARATION OF SAID COORDINATION DRAWINGS AND TO OBTAIN ARCHITECT'S REVIEW AND CONCURRENCE THEREOF WILL RESULT IN

FORFEITURE OF THEIR RIGHT OF PAYMENT UNTIL SAID DRAWINGS ARE ACCEPTED.

- B. REPEATED VIOLATIONS OF THIS CONTRACTUAL REQUIREMENT MAY RESULT IN TECHNICAL DEFAULT OF THE AGREEMENT BETWEEN THE OWNER AND THE OFFENDING PRIME CONTRACTOR;

HOWEVER, THE FAILURE OF THE OWNER TO SO TERMINATE SHALL NOT RELIEVE THE CONTRACTOR FROM FUTURE COMPLIANCE WITH THE TERMS AND CONDITIONS OF THIS SECTION.

****End of Section****

SECTION 013115 - REQUESTS FOR INFORMATION (RFI)

PART 1 - GENERAL

- 1.1 This document is for issuance at the Post Bid/Pre-Construction Conference and specifies administrative and procedural requirements for handling requests for information (RFI's) made after award of Contract.
- 1.2 Attention is directed to Sections 013300 and 013200 of Division #1 as same concerns construction progress schedules, submittal schedules and submittals of shop drawings, samples and product data in general.
- 1.3 SUBMITTAL PROCEDURES: RFI's shall be submitted in the following manner:
 - A. One (1) completed copy of form following to Architect with copies to Owner (as directed) and appropriate Consultants with the following minimum information:
 1. Work identified by RFI listing affected Drawing(s) and specific detail(s) and Specification paragraph reference(s).
 2. Identify specific field conditions and "as-built" conditions on sketches attached to RFI submittal.
 3. If RFI addresses conflict(s) in, or between, Contract Documents, describe completely and provide such data necessary to permit thorough and proper response by affected discipline.
 4. Indicate proposed solution along with any impacts on cost and construction time.
 5. Listing of Trade/Specialty Contractors affected by RFI and indication that RFI proposal has been coordinated with said contractors.

INCOMPLETE RFI's WILL BE RETURNED TO CONTRACTOR WITHOUT ACTION TAKEN.

- 1.4 REVIEW PROCEDURES/ACTIONS
 - A. Architect/Engineer may request additional information or documentation as may be deemed necessary for fair evaluation of RFI.
 - B. Architect/Engineer will respond with reasonable promptness as outlined in Section 013300 in writing and may, if deemed appropriate, issue a "Bulletin" as a clarification to the Contract Documents.

End of Section

REQUEST FOR INFORMATION (RFI FORMAT)

Contractor:		Architect: KG&D Architects, PC	
Address:		Address: 285 Main Street, Mt. Kisco, NY 10549	
Telephone:		Telephone: 914-666-5900	
Fax:		Fax: 914-666-0051	
Email:		Email: Bmangan@kgdarchitects.com	
Project Name:		Project Location:	
RFI Number:	Date of Request:	Requested Date of Response (5 business days minimum):	
Description, complete with backup data as necessary attached hereto:			
Sketches of Conditions	Specification Paragraph Reference(s):	Drawing Reference(s):	
Proposed Solution:			
Cost Impact:		Time Impact:	
Trade/Specialty Contractors Affected:			
Trade/Specialty Contractors Coordinated With:			
Submitted By:			
Architect's Response:			
By:		Date of Response:	

SECTION 013119 - PROJECT MEETINGS

1.1 GENERAL

- A. Requirements set forth herein are in addition to and shall be considered as complementary to the Conditions of the Contract and the balance of Division #1 and Technical Specifications.
- B. All Contractors, Subcontractors, Sub-subcontractors, Vendors, and the like shall be required to familiarize themselves with said provisions.
- C. Definitions as apply to "Contractors" involved with the work of this Project shall be as set forth in Section 011000, Article 1.01.

1.2 REQUIREMENTS INCLUDED IN THIS SECTION

- A. Initial (Kick-Off or Orientation) Meeting
- B. Regular Project Meetings
- C. Job Progress Meetings
- D. Job Coordination Meetings
- E. Pre-Installation Conferences
- F. Recording

NOTE: As part of all individual meetings outlined above there shall be a Waste Management program discussion held with all responsible parties in attendance.

1.3 INITIAL (KICK-OFF OR ORIENTATION) MEETING

- A. The Owner's Representative will schedule the initial job meeting, prior to the start of any work, at the project site and will notify all parties concerned of the time and place of the meeting.
- B. Attendance:
 - 1. Prime Contractor (s) or Construction Manager if involved
 - 2. Owner's Representative or Owner.
 - 3. Architect and principal consultants.
 - 4. Major subcontractors and suppliers as deemed appropriate.
 - 5. Representative of Testing Laboratory if independent.
- C. Review and Discuss:
 - 1. Relation and coordination of various parties, and responsible personnel for each party.
 - 2. Use of premises, including office and storage areas, temporary controls, and security procedures.
 - 3. Waste management requirements as outlined in Section 017419.
 - 4. Construction schedule and critical work sequencing.
 - 5. Processing of:
 - a. Contract modifications.
 - b. Shop Drawings, Product Data, and Samples.
 - c. Applications for Payment.
 - d. Substitutions.
 - e. Requests for Information.
 - f. Other required submittals.
 - 6. Adequacy of distribution of Contract Documents.
 - 7. Procedures for maintaining contract closeout submittals.
 - 8. Installation and removal of temporary facilities.
- D. Notification procedures and extent of testing and inspection services

- E. The meeting will be conducted by the Architect and Owner's Representative and shall address the conduct of the job, lines of communications, and the like. Discussions on waste management requirements as outlined in Section 017419 shall be part of the agenda.
- F. All Contractors are required to attend.

1.4 REGULAR PROJECT MEETING AGENDA

- A. Coordinate the Work of the Project (Reference Section 013114).
- B. Establish a sound working relationship among the Contractors, the Architect, and the Owner.
- C. Review and update progress, submittal and delivery schedules.
- D. Review job progress.
- E. Review progress payment requests; change proposals and change orders.
- F. Expedite the work to completion within the project schedule.
- G. Provide a 2 week look ahead schedule.

1.5 JOB PROGRESS MEETINGS

- A. Unless otherwise directed, bi-weekly job meetings will be held by the Owner's Representative. Present at these meetings shall be EACH CONTRACTOR or a representative authorized to make commitments for action on behalf of the Contractor and the Owner.
- B. EACH CONTRACTOR shall arrange for the participation of its Subcontractors when their presence is required by the Owner's Representative and/or the Architect.
- C. The minimum agenda will cover:
 - 1. Review minutes of previous meetings.
 - 2. Note field observations, problems, and decisions.
 - 3. Identify present problems and resolve them.
 - 4. Plan work progress during next work period and its effect on the related work of others.
 - 5. Review shop drawings and submittal schedules.
 - 6. Review change order status.
 - 7. Review status of construction progress schedule.
 - 8. Coordinate occupancy arrangements and access requirements with Owner.
 - 9. Discussions on waste management requirements as outlined in Section 017419 shall be part of the agenda.

1.6 JOB COORDINATION MEETINGS (Reference Section 013114)

- A. On a bi-weekly basis, either on the day of the schedule job progress meeting, or such other time established, a "working" coordination meeting will be held at the project site. Present at these meetings shall be **each contractor's site supervisor** with men working, or **scheduled to work within the ensuing 2 weeks**, and the Owner's site Representative.

Further, prior to the start of any major trade work, a coordination meeting following the guidelines established herein shall be held subject to the same parties' presence as for general meetings.

- B. Meeting shall be used to coordinate work between contracts for the ensuing 2 weeks. At the close of the meeting, each supervisor shall, in an agreed format,

provide a summarized 2 week work plan to the other contractors and the Owner's Representative.

- C. The time and place for the meetings will be as established in the preconstruction meeting.
- D. Minutes will be taken by the Construction Manager and distributed to all parties involved and the Construction Manager will provide, at the next regular progress meeting, a verbal report of the date and time of the last coordination meeting and a listing of those present.

1.7 PRE-INSTALLATION CONFERENCES

- A. Where required in individual specification Section, convene a pre-installation conference at project site or other designated location.
- B. Require attendance of parties directly affecting or affected by work of the specific Section.
- C. Review conditions of installation, preparation and installation procedures, and coordination with related work.

1.8 RECORDING: The Construction Manager shall write minutes of all meetings and distribute them to all parties present and to those on the distribution list given out at the orientation meeting within 48 hours of the meeting.

PART 2 PRODUCTS

Not used

PART 3 EXECUTION

Not used

****End of Section****

THIS PAGE INTENTIONALLY LEFT BLANK

SECTION 013200 - SCHEDULING AND PROGRESS

1.1 GENERAL

- A. Requirements set forth herein are in addition to and shall be considered as complementary to the "Conditions of the Contract" and the balance of Division #1 and Technical Specifications.
- B. Contractor, Subcontractors, Sub-subcontractors, Vendors and the like shall be required to familiarize themselves with said provisions.
- C. Definitions as apply to "Contractor" involved with the work of this Project.
 - 1. "Contractor for General Construction (CGC)" meaning the party responsible for the preparation of, and monitoring of, the Coordinated Project Progress Schedule (CPPS);
 - 2. "Coordinated Project Progress Schedule (CPPS)" meaning that schedule prepared by the "Contractor for General Construction".and such other terms relating to Contractors to be taken in context with respect to referenced work.

1.2 REQUIREMENTS INCLUDED IN THIS SECTION

- A. Preliminary Requirements
- B. Commencement, Prosecution and Completion of the work
- C. Coordinated Submittal Schedules
- D. Proposed Product List and Status Report on Material Orders - See Article 1.11 of Section 013300; failure to comply with these requirements shall result in rejection of schedules and withholding of any requisitions.
- E. Coordinated Project Progress Schedule
- F. Breach of Contract
- G. Time of Completion

1.3 PRELIMINARY REQUIREMENTS (Coordinate with Post-Bid Requirements set forth in Section 002100)

- A. Within seven (7) days after bids are opened, and before the Contract is executed, the three (3) apparent low bidders must submit to the Architect, in writing, a list of duration's and a sequence, in the form of a bar chart, for all activities that are the responsibility of the bidder. Contractor's proposed work force and other resource loading for each activity of the bar chart, broken down by trades, must also be provided. Failure to comply with this requirement may be cause for rejection of the bid.
- B. The apparent low bidders, concurrent with the submission of bar chart for each school, shall also submit to the Architect, in writing, the following information:
 - 1. Shop drawing and material sample schedules keyed to the duration's submitted in the bar chart. (See Section 013300)
 - 2. Schedules for the award of subcontractor and equipment contracts keyed to the duration's submitted for the bar chart.
 - 3. The name of the person who, as Scheduling Coordinator for the apparent low bidder, is authorized to act on behalf of the apparent low bidder on all matters of scheduling included in this Section. Once named, the Scheduling Coordinator may only be replaced after written notice is given to the Owner's Representative and Architect. The Contractor agrees, upon the request of either of the two parties, to replace the Scheduling Coordinator.

- C. Failure to comply with this subsection 1.03 of this Section of the General Requirements may be cause for rejection of the bid and forfeiture of security. (See the "Post-Bid Procedures" in the Instructions to Bidders.)

1.4 COMMENCEMENT, PROSECUTION AND COMPLETION OF THE WORK

- A. Contractor shall commence work under this contract upon receipt by him of Letter of Intent to Award, Notice to Proceed, and/or Execution of the Contract, and shall prosecute said work diligently and complete the work within the stated calendar days for each portion of the work as set forth in Section 011000.
- B. The time stated for completion for contract work includes final cleanup of area. Upon completion of total Contract work, ALL AREAS SHALL BE CLEAN.
- C. The Contractor is to carry on responsibility for services and maintenance of such items as temporary roads, walks, ramps, field offices, parking areas, environmental controls and the like until work under this contract is complete, unless otherwise directed by the Owner. Coordinate work herein with Section 01 10 00, Description of Work.

1.5 COORDINATED SUBMITTAL SCHEDULES

- A. Within two (2) weeks after receipt of Letter of Intent to Award, Notice to Proceed, and/or Execution of the Contract, Contractor shall submit, a detailed listing of all items to be incorporated within the work.

This information will be incorporated in the "CPPS" as prepared by the "CGC" in accordance with Paragraph 1.05 of this Section.

Listing should generally include the following:

1. Overall project milestones;
2. Proposed products list and status report on material orders.
3. Dates of shop drawing/sample submittals;
4. Guaranteed delivery dates after shop drawing and/or sample approvals;
5. Date of installation start;
6. Date of installation completion.

1.6 COORDINATED PROJECT PROGRESS SCHEDULE

- A. Within two (2) weeks after receipt of Letter of Intent to Award, Notice to Proceed, and/or Execution of the Contract, but prior to the actual start of the field work, the Contractor for General Construction shall submit to the Architect for his approval the proposed Coordinated Project Progress Schedule giving the information listed below.

The minimum information contained within the required project progress schedule shall consist of -

1. The estimated dates the various classes of work included in the Schedule of Values will be started and completed.
2. The estimated percentages of completion to be obtained and the total dollar value of the various classes of said work projected to the end of each calendar month until substantial completion.

Calculations shall be based upon - work in place; materials on site and not installed; materials fabricated and stored under suitable conditions and

insured to full value in a manner satisfactory to Architect and Owner; and such other items as may be agreed to among the Contractor, Architect and Owner.

3. The estimated delivery and installation dates of the major pieces of equipment to be furnished and installed by the Contractor.
 4. The estimated projected progress of work that will be performed away from the job site.
 5. A delineation of the work that will be performed by the Contractor's own forces and by his Subcontractors.
 6. The estimated calendar dates on which all the work under the contract will be completed and ready for substantial completion and final inspections.
- B. The Coordinated Project Progress Schedule shall be based on an orderly progression of the Work, allowing adequate time for each operation, and leading to a reasonable certainty of Substantial Completion by the date established in Section 011000.

The "CPPS" will be reviewed by the Architect and Owner's Representative for compliance with the requirements of this article and will be accepted by them or returned to the "CGC" for revision and resubmittal.

In the event that said schedule is returned, contractor shall participate in the revision, as required, to prepare same for resubmittal.

Unless specifically required by law, no payment under this Contract shall be due until the Progress Schedule has been submitted to the Architect and Owner's Representative and approved by both parties.

- C. As the work progresses, an up-to-date copy of the "CPPS" with the actual percent completion of the various classes of the work indicated in red shall be submitted by the "CGC", to the Architect and/or Owner's Representative during the first week of each calendar month. (Distribution to be established as part of "preconstruction meeting".

Contractor shall sign the monthly schedules as a prerequisite to the requisitioning process.

The "CPPS" may be adjusted and revised to meet unforeseen job conditions, but such changes shall, at all times, be approved by the Architect and the Owner's Representative.

- D. A copy of the "CPPS" shall be available at all times at the job site for the inspection and guidance of Subcontractors and Vendors engaged on any construction phase of the project.

It shall be the responsibility of Contractor to ascertain that all his Subcontractors, Vendors and Material men periodically consult the Schedule so that their work schedule shall be maintained in conformance with his own.

- E. AN UP TO DATE COPY OF COORDINATED PROJECT PROGRESS SCHEDULE

MUST BE ATTACHED TO MONTHLY REQUISITION IN ORDER FOR PROCESSING TO BEGIN. The CPPS submitted with each monthly requisition must either be signed by the Prime Contractor or accompanied by a document indicating that the Contractor will comply with the CPPS as submitted.

INCOMPLETE REQUISITIONS WILL BE REJECTED.

1.7 BREACH OF CONTRACT

A. The Contractor's failure to comply with any requirement called for in subsections 1.04, 1.05 and 1.06 above shall constitute a material breach of the Contract, and the Owner shall have the right to and may terminate the Contract, provided, however, that the failure of the Owner to so terminate shall not relieve the Contractor from future compliance.

1.8 TIME OF COMPLETION – Coordinate with Article 8, Sections 007000 and 011000

A. Notwithstanding the implementation of the Construction Schedule, it is the sole responsibility of the Contractor to complete the Work within a Contract Time which will assure the substantial completion of the Project by the required date.

****End of Section****

SECTION 013300 - SUBMITTAL REQUIREMENTS

1.1 GENERAL

- A. Requirements set forth herein are in addition to and shall be considered as complementary to the Conditions of the Contract and the balance of Division #1 and Technical Specifications.
- B. All Contractors, Subcontractors, Sub-subcontractors, Vendors and the like shall be required to familiarize themselves with said provisions.
- C. Definitions as apply to "Contractors" involved with the work of this Project shall be as set forth in Section 007000, Article 1.1
- D. Where practical, submittals shall be made in groupings where installations are complimentary, i.e. steel, steel decking, steel stairs, stair railings; roof systems/flashings; etc. **Failure to comply with this requirement will be cause for rejection of any or all submittals.**

Coordinate each submittal with fabrication, purchasing, testing, delivery, other submittals, and related activities that require sequential activity.

Architect reserves the right to withhold action on a submittal requiring coordination with other submittals until related submittals are received.

- E. The Contractor is encouraged to submit for approval products made from recycled and/or environmentally responsible material. Every effort will be made by the Design Professional Team to approve these materials; the substitution request procedure shall still be enforced.

1.2 REQUIREMENTS INCLUDED IN THIS SECTION

- A. Related Work Specified Elsewhere.
- B. Approved Equal Clause/Substitutions/Options
- C. Certification.
- D. Manufacturer's Instructions
- E. Submittal Instructions
- F. Shop Drawings
- G. Samples
- H. Material Safety Data Sheet (MSDS) Submittals
- I. Proposed Products List and Status Report on Material Orders
- J. Scheduling of Submittals
- K. Job Progress Schedule - See Section 013200
- L. Coordination Drawings
- M. Progress Photographs
- N. Certificates
- O. Construction Waste Management Procedures and Certifications – See Section 017419.
- P. V.O.C. Compliance certification – See individual technical sections.

1.3 RELATED WORK SPECIFIED ELSEWHERE

- A. 012900 - Applications for Payment and the Schedule of Values .
- B. 013113/14 - Project Coordination and Coordination Drawings.
- C. 013200 - Scheduling and Progress.
- D. 014326 - Testing Laboratory test and inspection reports.
- E. 017700 - Project Closeout requirements.

- F. 017719 - Project Record Documents.
- G. 017823 - Operation and Maintenance.
- H. Divisions 2 through 33 Sections for specific requirements for submittals in those Sections.

1.4 APPROVED EQUAL CLAUSE/SUBSTITUTIONS/OPTIONS - Section 012500

1.5 CERTIFICATION

- A. Certification of compliance with specification performance standards and manufacturers' specifications and directions shall be furnished for any portion of this work for which specific performance requirements and/or manufacturers' specifications are listed. It shall be the responsibility of the Contractor to secure two (2) copies of each certification when required and transmit same to the Architect.
- B. Sample Certification Form (2 pages) Section 013306 as an exhibit at the close of this Section. Each item requiring certification shall be so noted and affidavits shall be filed singly to cover each specified material, installation, application and the like. CERTIFICATIONS SHALL BE SUBMITTED AS PART OF THE CLOSE OUT DOCUMENT REQUIREMENTS SET FORTH IN SECTION 017700.
- C. Decorations, Furnishings and Interior Finish - The Contractor's attention is directed to the New York State Fire Code as it relates to regulations controlling decoration, furnishings and interior finishes as they affect the work of this Contract.

It is deemed the sole responsibility of the vendors furnishing fabrics, floor coverings, ceiling finishes, wall coverings and finishes and the like as covered by the regulations to submit applications and obtain approvals for same without additional charges to the Owner. Failure to obtain, and submit, approvals in accordance with requirements of this section will result in rejection of any submittal for this phase of the work.

- D. Packaged Equipment: Where packaged (factory assembled) mechanical and electrical equipment is furnished, a certificate shall be included with the submission of shop drawings or catalog data stating that the equipment complies with OSHA, National Electric Code, and applicable Underwriter's Laboratories Standards in respect to motor protection, grounding and protection against hazards, and is approved by all Regulatory Agencies.

1.6 MANUFACTURER'S INSTRUCTIONS

- A. Where in these specifications an item is called for to be installed in accordance with the manufacturer's directions, specifications or recommendations, the Contractor shall furnish the Architect with two (2) printed copies of said directions, specifications or recommendations, before the item is installed.

1.7 SUBMITTAL INSTRUCTIONS

- A. Transmit each submittal, except sample installations and sample panels to the Architect. Transmit submittals with Submittal Cover Sheet attached as Section 013303. On the Cover Sheet identify Contractor, indicate date of submittal, and include information prescribed by form and required in paragraph entitled, "Submittal Requirements" of the individual technical Section and as follows. Process transmittal forms to record actions regarding sample installations and panels.

1. Name, address, and telephone number of the subcontractor, supplier, manufacturer, and any other subcontractor associated with the submittal.
2. Name of Owner.
3. Name of Project and location.
4. Construction contract number/designation.
5. Product Identification.
6. Manufacturer.
7. Subcontractor/Supplier.
8. Spec Section No.
9. Spec Paragraph/Article.
10. Drawing No(s).
11. Drawing Date(s).
12. Room or Detail No(s).
13. When a resubmission, add alphabetic suffix on submittal description, for example, submittal 18 would become 18A, to indicate resubmission.

1.8 SHOP DRAWINGS

A. The following serves as a further definition of the requirements for shop drawing submittals as covered in Article 3.12 of the General Conditions:

1. The Contractor shall submit to the Architect with such promptness as to cause no delay in the work, layout, detail, schedule, setting, product data and shop drawings for each part of the work as specified or required.
 - a. Submission of data for review by the Structural and Mechanical/Electrical Engineers shall be sent directly to those Engineers with duplicate transmittals sent to the Architect.
2. BEFORE SUBMITTING ANY DATA FOR APPROVAL, THE CONTRACTOR SHALL CHECK THE SUBMITTALS OF ALL SUBCONTRACTORS FOR ACCURACY AND CONTRACT COMPLIANCE. ALL SUBMITTALS SHALL BE UNDER THE COVER SHEET ATTACHED HERETO. SUBMITTALS NOT COMPLYING WITH THE ABOVE SHALL BE RETURNED TO THE SUBMITTING CONTRACTOR WITHOUT EXAMINATION BY THE ARCHITECT. Contractor shall see that all work contiguous with and having bearing on work indicated on drawings is accurately and distinctly illustrated and that work shown is in conformity with contract requirements.

EACH CONTRACTOR SHALL BE RESPONSIBLE FOR COORDINATING THEIR WORK AND SUBMITTAL WITH OTHER CONTRACTORS PERFORMING WORK ON THE PROJECT.

SHOULD ANY CONTRACTOR CAUSE THE NEED FOR RE-SUBMISSION OR RE-REVIEWS OF PREVIOUSLY APPROVED INFORMATION OF ANOTHER CONTRACTOR, ALL COSTS INVOLVED WITH SAID REVIEW WILL BE BACKCHARGED AT THE RATES SET FORTH IN SECTION 012500 TO THE CONTRACTOR CREATING THE NEED FOR ADDITIONAL REVIEWS.

3. Shop drawings shall be numbered consecutively and shall represent:
 - a. All working and erection dimensions.
 - b. Arrangement and sectional views.

- c. Necessary details, including information for making connections to other work.
- d. Kinds of materials and finishes. Colors, where applicable
4. Shop drawings shall be dated, and shall generally contain:
 - a. Name and Number of project.
 - b. Name, address and telephone number of submitting Contractor.
 - c. Description of required equipment, materials, and classification item numbers.
 - d. Locations at which materials or equipment are to be installed in the Work.
 - e. Identification of drawings, schedules, notes and/or details and specification sections and related paragraphs/articles to which they apply.
 - f. Equipment or fixture identification corresponding to that used in Contract Documents.
 - g. Accessories and special or non-standard features and materials which are being furnished.
 - h. Properly marked with external connection identification as related to the project where they consist of standard factory assembly or field installation drawings.

In addition to the general data required above, mechanical and electrical submissions shall contain:

- a. Manufacturer's specifications including materials of construction, metal gauge, thickness and finish.
- b. Certified dimensional drawings including clearances required for maintenance or access (coordinate with Section 013114)
- c. Performance data, ratings, operating characteristics, and operating limits.
- d. Electrical ratings and characteristics.
- e. Wiring and control diagrams, where applicable.
- f. Certifications requested, including UL label or listing.
- g. List of accessories which are required but are NOT being provided by the product manufacturer or are NOT being furnished under this Section. Identify the Section(s) under which the accessories are being furnished.
5. Submission of data for approval shall be accompanied by letter of transmittal, in duplicate, containing the name of the project, Contractor's name, number of drawings, titles and other pertinent data.
6. Procedure for Submitting Shop Drawings and Product Data:

The contractor shall submit five (5) copies of data, for standard manufactured items, in the form of manufacturer's catalog sheets, showing illustrated cuts of the items to be furnished, scale details, sizes, dimensions, performance characteristics, operating clearances, capacities, wiring diagrams and all other pertinent information.

Two copies of reviewed submissions will be returned to the contractor.

For all other shop drawings, Contractor shall submit one transparency for each drawing until final approval is obtained.

Each drawing transparency shall have a clear space approximately 4 inches by 10 inches on the right hand side for stamps showing "Date Received" and disposition of submittal.

In addition to the transparency, three (3) prints shall be required.

- a. After completion of checking, the Architect, and Engineer (as appropriate) will retain one print for his record and return the transparencies to the submitting Contractor.

The average "turn around time" of any one in-house submittal by the Architect shall not exceed 15 business days for review and at least 20 business days when another consultant is involved.

- b. For drawings returned "Resubmit", "Amend & Resubmit", "Disapproved" or "Rejected-Resubmit", the original drawings shall be corrected, a new transparency made, and resubmitted until final approval.

NOTE: The Owner reserves the right to backcharge the Contractor for the additional costs beyond the review of any resubmittal as outlined in Section 012500.

- c. For drawings returned "Approved", "No Exceptions Taken", "Approved as Noted", and "Make Corrections Noted", the Contractor shall obtain and provide sufficient prints as required for the field.

NOTE: It is the responsibility of the contractor to confirm all dimensions, quantities, and the coordination of materials and products supplied by him with other trades. Approval of shop drawings containing errors does not relieve the contractor from making corrections at his expense.

7. No work as called for by shop drawings shall be done until Architect's approval.
8. IF SUBMITTALS SHOW VARIATIONS FROM CONTRACT REQUIREMENTS BECAUSE OF STANDARD SHOP PRACTICES, OR OTHER REASONS, CONTRACTOR SHALL MAKE SPECIFIC MENTION OF SUCH VARIATION IN HIS LETTER OF TRANSMITTAL.
9. APPROVAL OF SHOP DRAWINGS IS GENERAL. IT SHALL NOT RELIEVE CONTRACTOR OF THE RESPONSIBILITY FOR ACCURACY OF SUCH DRAWINGS, NOR FOR THE FURNISHING OF MATERIALS OR PROVISION OF WORK REQUIRED BY THE CONTRACT AND NOT SHOWN ON THE SHOP DRAWINGS.

Unless it is an interpretation of design intent, approval of shop drawings shall not be construed as approval of departures from Contract.

10. If the Contractor should alter any information on previous submittals, besides the notations called for by the Architect, he must circle this new information to bring it to the Architect's attention.
11. ***Where practical, in submitting data for approval, all associated drawings, product data and the like, relating to a complete assembly shall be submitted at one and the same time so that each may be checked in relation to the entire proposed assembly.***

PARTIAL SUBMISSIONS WILL BE RETURNED WITHOUT ACTION TAKEN.

EXTRANEIOUS MATERIAL ON PRODUCT DATA SHEETS SHALL BE STRUCK PRIOR TO SUBMITTAL.

Resubmittals of any data shall be "complete", i.e. – Lighting Fixture resubmittal shall include all fixtures whether or not some have been approved so that when the entire submittal is approved, a full record copy is on file.

12. Contractor shall have copies of all approved shop drawings as listed in Paragraph 1.08.A.6 above on the job at all times and shall make them available to the Architect or the Owner's representatives.

1.9 SAMPLES

- A. The following serves as a further definition of the requirements for sample submittals as covered in Article 3.12 of the General Conditions:
 1. Names of proposed manufacturers, materialmen and dealers who are to furnish materials, fixtures, appliances or other fittings shall, where practical, be submitted to the Architect for early approval to afford proper investigation and check.
 2. No manufacturer will be approved for any materials to be furnished under this contract unless he shall be of good reputation and shall have plant of ample capacity and shall have successfully produced similar products.
 3. All transactions with manufacturers and subcontractors shall be through the Prime Contractor.
 4. Unless otherwise specified, samples shall be in duplicate (2) and of adequate size to show quality, type, color, range, finish, texture, etc.

INTERRELATED COLOR SELECTIONS WILL NOT BE MADE UNTIL ALL PERTINENT SAMPLES ARE MADE AVAILABLE TO ARCHITECT.

Deliver one (1) sample to field office and one (1) sample to Architect's office unless otherwise directed.

5. Each sample shall be labeled, bearing material and quality names, submitting Contractor's name, and project name, and other pertinent data.

In accordance with OSHA regulation Number 1910.1200, a Material Safety Data Sheet (MSDS) shall be submitted for each product to be incorporated in the work.

The sole purpose for requiring submittal of MSDS sheets as outlined herein and respective technical sections is to advise the General Contractor that health and safety is of primary importance to the execution of the work and for the future occupants of the project under construction. It is to be assumed, and will be enforced, that the submission of MSDS sheets be made as a separate package, covered by its own transmittal and marked "for evidence of legal compliance". This submission will be noted and returned with a stamp indicating "SUBMITTED INFORMATION ONLY, NOT REVIEWED". **Failure to observe these submittal requirements will be cause for rejection of the entire submittal.**

The safe handling of products by the applicator according to MSDS warnings is a safety issue, like any other, entirely within the purview of the Respective Prime Contractor.

6. Where Specifications require manufacturer's printed installation directions, such directions and diagrams shall accompany samples. Coordinate with Paragraph 1.05 herein
7. A duplicate letter of transmittal from the submitting Contractor requesting approval of the sample shall accompany the samples.
8. Transportation charges to designated locations must be prepaid on all samples.
9. Materials shall not be ordered until approval is received in writing from the Architect.
10. ***All materials shall be furnished equal in all respects to the samples which were approved.***

1.10 MATERIAL SAFETY DATA SHEET (MSDS) SUBMITTALS

- A. As specified in Paragraph 1.09 of this Section and within the technical sections forming this Specification, the Contractor is directed to the following requirements concerning "MSDS" submissions.
 1. Submit MSDS's only to the Construction Manager for filing on the project site for all products used during construction whether incorporated within the work or used in the performance of the work. The Architect does not review MSDS sheets and will not hold them for record purposes.
 2. Identify which products may be harmful to construction workers or other building occupants.
 3. Develop means and methods for protection of construction workers and other building occupants from potentially harmful products. **Submit said means and methods to the Construction Manager for record keeping only.**
- B. Further, all prime contractors shall maintain a "MSDS" file on site, accessible to workers and otherwise in compliance with jurisdiction's "Right To Know" legislation.
- C. **Attention is directed Section 017700, Article 1.04.A.12 for final closeout submittal of MSDS compilation to the Owner.**

1.11 PROPOSED PRODUCTS LIST AND STATUS REPORT ON MATERIAL ORDERS - Coordinate with Section 013200.

- A. Within two (2) weeks after date of Notice to Proceed or execution of the Contract (whichever is the earliest), submit a complete list of products proposed for use, with name of manufacturer/vendor/fabricator, trade name, and model number of each product.
- B. For products specified only by reference standards, give manufacturer, trade name, model or catalog designation, and reference standards.
- C. Report to include list, in chronological order by need date, materials orders necessary for completion of the contract. The following information will be required for each material order listed:
 - 1. Material name, supplier, and invoice number.
 - 2. Bar chart line item or CPM activity number affected by the order.
 - 3. Delivery date needed to allow directly and indirectly related work to be completed within the contract performance period.
 - 4. Current delivery date agreed on by supplier.
 - 5. When item 4 exceeds item 3, the effect that delayed delivery date will have on contract completion date.
 - 6. When item 4 exceeds item 3, a summary of efforts made by the Contractor to expedite the delayed delivery date to bring it in line with the needed delivery date, including efforts made to place the order (or subcontract) with other suppliers.

NOTE: This information shall be updated for each requisition, failure to complete and certify accuracy will be cause for non-payment of requisition.

1.12 SCHEDULING OF SUBMITTALS

- A. Within two (2) weeks after execution of the Contract, the Contractor shall submit a detailed listing of all items to be incorporated within the work, including all items of mechanical and electrical.
 - 1. Submittals for Review.
 - 2. Quality Control Submittals.
 - 3. Sustainable Design Submittals.
 - 4. Closeout Submittals.

Listing should state the following:

- 1. Specification section number.
- 2. Description of submittal.
- 3. Type of submittal.
- 4. Date of shop drawing/sample submittals.
- 5. Guaranteed delivery date after shop drawing and/or sample approvals.
- 6. Date of installation start.
- 7. Date of installation completion.

1.13 JOB PROGRESS SCHEDULE - See Section 013200

1.14 COORDINATION DRAWINGS

- A. Each Contractor's attention is directed to Section 013114 for required coordination drawings and the responsibility therefore.

1.15 PROGRESS PHOTOGRAPHS

- A. This Article includes requirements for periodic construction photography by the General Contractor, utilizing digital camera equipment, to demonstrate construction

progress and to serve as a communicative device when describing a given condition to others at a remote location, by means of the internet.

- B. Photography shall be taken using a digital camera and electronic program which will download the digital photos in a JPEG format to a computer with resolution adequate to demonstrate the item under discussion.
- C. One set of record prints will be required and filed with the monthly requisition. The JPEG files shall be transmitted to the appropriate parties who shall then have the option to view the picture(s) on screen or print them out using their own equipment.
- D. It is the intention of this Section to provide a tool to enhance communications and reduce the amount of time required to address questions arising at the Project site. In this end, the Contractor shall utilize good judgment in providing photographs that are informative, and not merely repeating what is shown in the other photographs.
- E. Provide factual representation of construction extent and conditions. Provide correct exposure and focus, high resolution and sharpness, maximum depth of field, and minimum distortion, utilizing a normal lens.
- F. Before starting work, the General Contractor shall take photographs of the Work Areas from different points of view sufficient in number to show all present conditions.
- G. The minimum requirements, per requisition period are three (3) photographs of the Work, from different points of view designated by the Architect

1.16 CERTIFICATES

- A. Submit a Summary of Solid Wastes Generated, manifests, weight tickets, and the like in accordance with requirements of Section 017419 - Construction Waste Management.
- B. Submit, as required by each technical section a certification for V.O.C. compliance.

PART 2 - PRODUCTS

Not used

PART 3 - EXECUTION

Not used

****End of Section****

THIS PAGE INTENTIONALLY LEFT BLANK

CONTRACTOR REQUEST FOR ELECTRONIC DRAWING FILES

The Architect, for the convenience of the Client/Owner, has electronic copies or representations of Drawings, Specifications and Project Manuals. Requests for electronic copies of such Drawings, Specifications and Project Manuals by the Contractor, for the Contractor's use or the use of Subcontractors, shall be made in writing to the Client/Owner as outlined herein below and shall outline the benefit derived from such a request. The Contractor shall be prepared to reimburse the Client/Owner for any costs involved in preparing such electronic documents for the Contractor's use.

Architect's Project Number:	
Project Name:	
Architect:	
Client/Owner:	
Contractor/Recipient's Name:	
Attention to:	
Contractor/Recipient's Address:	
Date of Request:	
Date of Release:	

As requested, attached is a list of electronic drawing files in DWG/DWF format (Drawings may be compressed). For the release of these electronic drawing files to the recipient, the following items shall be understood, acknowledged and signed by the authorized personnel of the recipient with the fee included as may be required.

- A. The electronic drawing files are the property of the Architect, and the Contractor is granted a license to use the electronic files only in connection with the subject project.
- B. The electronic drawing files do not necessarily represent the Contract Documents associated with the referenced project. These files are solely for the use of the recipient and are not a representation of the scope of work for the project. Any use by contractors, subcontractors or fabricators shall be on all the same terms and conditions being applicable to such users who shall acknowledge the same in writing. The Recipient may use the electronic drawing files only. Electronic drawing files or portions thereof, shall not be provided to anyone else without the written approval of the Client/Owner. The use of the electronic drawing files, documents and any reprographics shall not identify any member of the Architect or Architect's consultants or sub-consultants or the Client/Owner without the written approval from the parties.
- C. The entire risks as to the results and performance of the package including the electronic drawing files, are assumed by the Contractor/recipient. The Client/Owner, the Architect and the Architect's consultants and sub-consultants, including directors, employees, representatives, and licensors of the company, shall not have any liability to the Contractor/recipient or any other person or entity for any direct, indirect, incidental special or consequential damages whatsoever, including, but not limited to, the loss of revenue or profit, lost data, or any other personnel, commercial or economic loss, and claims by third parties. Even if the Client/Owner and Architect and the Architect's consultants and sub-consultants has been advised of the possibility of such damages; said Client/Owner

and Architect and the Architect's consultants and sub-consultants shall not be held liable as stated above.

- D. The Contractor/recipient hereby agrees to indemnify and hold the Client/Owner, the Architect and the Architect's consultants and sub-consultants harmless from and against any cost, damage, liability, loss or claim arising from violation of this license. The Contractor/recipient and all subcontractors of all tiers also agrees that, in addition to all other remedies hereunder, the Contractor/recipient and such parties grant the Client/Owner the right to seek injunctive or other equitable relief to prevent the violation or require the performance of any of the Contractor's/recipient's obligations under this license, and the Contractor/recipient hereby consents to the issuance of such relief by any court of competent jurisdiction without the need to post any bond or security.
- E. The electronic files requested are as follows:

Electronic file name	Corresponding Drawing (close approximation)
1.	
2.	
3.	
Etc.	
Total number of files:	

CONTRACTOR'S/RECIPIENT'S AGENT SIGNATURE: _____

NAME IN BLOCK LETTERS: _____

AUTHORIZED POSITION HELD: _____

DATE OF SIGNATURE: _____

****End of Attachment****

THIS PAGE INTENTIONALLY LEFT BLANK

Owner: Yonkers Joint Schools Construction Board
Project: Community School 35
Contractor:
Date:
Re: Agreement of Use of Design Team Building Information Model by Contractor

As per your request, Kaeyer Garment + Davidson Architects is prepared to provide the Contractor with copies of its Building Information Model (“BIM”) files for the above-mentioned project. However, it is expressly understood that the BIM files are being issued only as supplemental information for convenience to the Contractor. BIM files, like any electronic data, transferred in any manner or translated from the system and format used by all the design professionals on this Project (“Design Team”) to another system or format are subject to errors and modifications that may affect the accuracy and reliability of the data, and, in addition, that electronic data may be altered or corrupted whether inadvertently or otherwise. No representations or warranties, whether expressed or implied, as to the accuracy of the BIM files transferred are made herein. As the accuracy of the BIM files cannot be warranted or guaranteed, it is issued as supplemental information only and must be read in conjunction with the contract documents, and to the extent there are any discrepancies between the BIM files and the contract documents, the contract documents must be relied upon.

The BIM files provided by the Design Team under the terms of this Agreement are the proprietary information and the property of the Design Team, who shall maintain all copyright and intellectual property rights in the BIM files. All BIM files shall be treated as confidential and are not to be disclosed to or shared with others without the Design Team’s written consent. The use of the BIM files for any other purpose other than for supplemental information for convenience is prohibited. Coordination drawings, submittals and other like materials developed or created with use of the BIM model shall be provided to the Architect, for convenience and use and supplemental to any and all submittals, in the digital format as the original model.

By signing the release below you are acknowledging that 1) Owner and the entire Design Team shall be held harmless from any and all claims, liabilities, damages, losses, or expenses arising out the contractor’s use of the BIM files and cannot be held responsible for any errors or omissions within the BIM files, 2) the BIM files are to be read in conjunction with all construction documents, addenda and supplemental contract documents, and 3) the BIM files are not to be used for fabrication or construction of any kind.

Accepted By: **CONTRACTOR**

Representative	Title

Signature	Date

SUBMITTAL COVER SHEET

Contractor: _____

Address: _____ Telephone: () _____

Owner: Yonkers Joint Schools Construction Board
Name of Project: Community School 35

TYPE OF SUBMITTAL:

- | | | |
|---|--------------------------------------|--|
| <input type="checkbox"/> Shop Drawings | <input type="checkbox"/> Schedule | <input type="checkbox"/> Physical Sample |
| <input type="checkbox"/> Technical Data | <input type="checkbox"/> Certificate | <input type="checkbox"/> Color Sample |
| <input type="checkbox"/> Test Report | <input type="checkbox"/> Warranty | <input type="checkbox"/> _____ |

Submission #: 1st, 2nd, 3rd, 4th (circle one)

<p>Description:</p> <p>Product Identification: _____</p> <p>Manufacturer: _____</p> <p>Subcontractor/Supplier: _____</p> <p>DOCUMENT REFERENCES: (Must be fully filled out)</p> <p>Spec Section No.: _____ Drawing No(s): _____</p> <p>Paragraph: _____ Rm. Or Det. No(s): _____</p>
--

Contractor Remarks:

Contractor Submittal Review Stamp

THE ATTACHED MATERIAL HAS BEEN REVIEWED BY THE UNDERSIGNED AND IS BELIEVED TO COMPLY WITH ALL REQUIREMENTS OF THE CONTRACT DOCUMENTS. THE UNDERSIGNED UNDERSTANDS VERIFICATION OF FIELD DIMENSIONS, AND COORDINATION WITH OTHER TRADES, REMAINS THE RESPONSIBILITY OF THE CONTRACTOR.

DATE: _____ BY (SIGN): _____

Consultant use below this line:

Architect Submittal Review Stamp

- | | |
|--|---|
| <input type="checkbox"/> NO EXCEPTIONS | <input type="checkbox"/> MAKE CORRECTIONS NOTED |
| <input type="checkbox"/> REJECTED | <input type="checkbox"/> REVISE AND RESUBMIT |
| <input type="checkbox"/> EXAMINED | <input type="checkbox"/> SUBMIT SPECIFIED ITEM |

CHECKING IS ONLY FOR GENERAL CONFORMANCE WITH THE DESIGN CONCEPT OF THE PROJECT AND GENERAL COMPLIANCE WITH THE INFORMATION GIVEN IN THE CONTRACT DOCUMENTS. ANY ACTION SHOWN IS SUBJECT TO THE REQUIREMENTS OF THE PLANS & SPECIFICATIONS. CONTRACTOR IS RESPONSIBLE FOR DIMENSIONS WHICH SHALL BE CONFIRMED & CORRELATED AT THE JOB SITE; FABRICATION PROCESSES AND TECHNIQUES OF CONSTRUCTION; COORDINATION OF HIS WORK WITH THAT OF ALL OTHER TRADES & THE SATISFACTORY PERFORMANCE OF HIS WORK

KAEYER, GARMENT + DAVIDSON ARCHITECTS, P.C.

DATE _____ BY _____

SECTION 013306 - CERTIFICATION OF SPECIFICATION COMPLIANCE

I/WE, the MANUFACTURER/SUPPLIER and INSTALLER of

_____ as specified in Section Number _____ of

the Contract Documents prepared by KG+D, Architects P.C., 285 Main Street; Mt. Kisco, NY 10549,
for the New Community School at the St. Denis Site,

do herein certify that:

1. All materials furnished for said project do fully comply with all specification requirements as stated within the Contract Documents;
2. That no asbestos containing materials of any nature are used in the work;
3. That execution of the Work covered by this certification has been performed in accordance with the drawings prepared by the design professional team.

CONTRACTOR: _____

CERTIFICATION BY: _____ TITLE: _____

ADDRESS: _____

CERTIFICATION DATED: _____

Distribution:

Original and One Copy to:

KG+D Architects, PC
285 Main Street
Mt. Kisco, NY 10549

Att: _____

One Copy to:

CERTIFICATION OF SPECIFICATION COMPLIANCE

CORPORATE ACKNOWLEDGEMENT

State of _____)SS.
County of _____)

On the _____ day of _____, before me came _____ to me known and who by me being duly sworn did depose and say that he resides at _____ that he is the officer of the said corporation executing the foregoing instrument, that he knows the seal of said corporation, that the seal affixed to said instrument is such corporate seal, that it was so affixed by order of the Board of Directors of said corporation and that he signed his name thereto by like order.

Notary Public

INDIVIDUAL ACKNOWLEDGEMENT

State of _____)SS.
County of _____)

On the _____ day of _____, before me came _____ to me known and who by me being duly sworn did depose and say that he resides at _____ that he is the individual who executed the foregoing instrument.

Notary Public

PARTNERSHIP ACKNOWLEDGEMENT

State of _____)SS.
County of _____)

On the _____ day of _____, before me came _____ to me known and who by me being duly sworn did depose and say that he resides at _____ that he is the partner in the firm of _____ doing business under the name of _____ and that he executed the foregoing instrument on behalf of said partnership.

Notary Public

THIS PAGE INTENTIONALLY LEFT BLANK

SECTION 013529 - HEALTH AND SAFETY PLAN

1.1 GENERAL

- A. Requirements set forth herein are in addition to and shall be considered as complementary to the Conditions of the Contract and the balance of Division #1 and Technical Specifications.
- B. All Contractors, Subcontractors, Sub-subcontractors, Vendors and the like shall be required to familiarize themselves with said provisions.
- C. Definitions as apply to "Contractors" involved with the work of this Project shall be as set forth in Section 011000, Article 1.01.

1.2 REQUIREMENTS INCLUDED IN THIS SECTION

- A. Provide all labor, equipment and materials and perform all operations in connection with monitoring air quality, decontaminating equipment and providing worker health and safety protection for all Contractor and Subcontractor personnel.
- B. Develop a site specific Health and Safety Plan (HASP) specifically addressing the potential hazards that may be encountered. This plan shall meet all Occupational Safety and Health Administration (OSHA) requirements.
- C. Review the requirements and data presented and supplement the program with any additional measures deemed necessary to fully comply with regulatory requirements and adequately protect personnel on the site.

1.3 REFERENCES

- A. OSHA Regulation 29 CFR 1910.120
- B. OSHA Regulation 29 CFR 1926.62

1.4 DEFINITIONS

- A. Site Safety Official (SSO): The individual who is responsible to the Contractor and has the authority and knowledge necessary to implement the site safety and health plan and verify compliance with applicable safety and health requirements.
- B. SSO shall possess full and complete authority to order stoppage of any work which he deems unsafe.

1.5 SUBMITTALS

- A. Provide within seven (7) days after execution of the Agreement.
 - 1. Site-specific HASP including the Emergency Response Plan to the Owner, Owner's Representative and Architect for review, including provisions for decontamination and a contingency plan for unforeseen emergencies. The review is only to determine if the HASP meets basic regulatory requirements and the minimum requirements of this Section. The review will not determine the adequacy of the HASP to address all potential hazards, as that remains the sole responsibility of the Contractor.
 - 2. Current certification of employee's health and safety training and certification of employee's baseline medical exam status.
 - 3. Certification of additional required health and safety training for Supervisors.
 - 4. Qualifications and experience of the SSO for approval.
- B. Submit minutes of weekly safety meetings at periodic progress meetings.
- C. Refer to related submittal requirements in Section (s) 028200 - Asbestos Abatement for project.

1.6 CONTRACTOR'S RESPONSIBILITIES

- A. Contractor is solely responsible for the health and safety of workers employed by the Contractor, any Subcontractor and anyone directly or indirectly employed by any of them.
- B. Develop and follow a site specific Health & Safety Plan (HASP) in accordance with the requirements of paragraph 1.07.
- C. Provide a full-time SSO regardless of whether or not the Work is at a defined Uncontrolled Hazardous Waste Site.
- D. Pre-arrange emergency medical care services at a nearby hospital, including establishment of emergency routes of travel.
- E. Meetings:
 - 1. Conduct daily job briefings with all site personnel to discuss relevant health and safety issues including but not limited to hazards, monitoring, procedures and controls. Document attendance and topics covered.
 - 2. At a minimum, conduct weekly safety meetings with all site personnel, documenting attendance and topics covered.
- F. Train all workers assigned to areas where contaminated media are likely to be encountered in accordance with 29 CFR 1910.120.
- G. Include those workers involved with the abatement of Asbestos containing materials in a medical surveillance program and respiratory protection program that meet the requirements of 29 CFR 1910.120 and 29 CFR 1910.134, respectively.
- H. In areas where contaminated media are likely to be encountered, monitor air quality in and around work area using appropriate air monitoring equipment/analysis, as indicated in Part 2. Record all readings and maintain record on site. Stop work and/or upgrade respiratory protection or personal protective equipment levels if action levels established in the HASP are exceeded. Ensure that degree and type of respiratory protection provided is consistent with the monitored concentrations and individual chemical parameters. Lawfully dispose of all contaminated clothing and equipment that cannot be decontaminated.

1.7 HEALTH & SAFETY PLAN (HASP) REQUIREMENTS

- A. The following items shall be addressed in the HASP:
 - 1. safety and health hazard assessment;
 - 2. procedures for emergency medical treatment and first aid;
 - 3. map indicating route to hospital for emergency medical care;
 - 4. Lead Exposure Control Plan (29 CFR 1926.62);
 - 5. equipment decontamination procedures;
 - 6. air monitoring procedures and action levels;
 - 7. personal protective equipment and decontamination;
 - 8. physical hazard evaluation and abatement including:
 - a. equipment operation;
 - b. confined space entry;
 - c. slips and falls;
 - d. building collapse;
 - e. falling debris;
 - f. encountering unmarked utilities;
 - g. cold and heat stress;
 - h. hot work (cutting and welding);
 - i. excavation entry;
 - 9. training requirements;

10. recordkeeping requirements;
11. emergency response plan that includes:
 - a. names of three (3) Emergency Response Contractors, experienced in the removal and disposal of oils and hazardous chemicals, that the Contractor intends to use in the event of an emergency;
 - b. evacuation routes and procedures;
 - c. emergency alerting and response procedures.

1.8 CONTINGENCY MEASURES & NOTIFICATIONS

- A. The potential for encountering hazardous buried objects or materials that could pose a threat to human health or the environment exists at the Project Site. In the event that potentially hazardous materials are encountered during the work under this contract, the responsibilities of the Contractor and the Owner's Representative are described herein.
- B. The procedures and protocols to be used by the SSO in defining materials that are potentially hazardous include screening with a photoionization detector, odor, visual appearance of a material, and obvious oil or chemical contaminated materials.
- C. Upon encountering suspected hazardous buried objects or materials as described above, cover the excavation immediately if no imminent danger, as defined by the SSO, is present. If there is an imminent danger, as defined by the SSO, evacuate the area immediately. The SSO shall then notify the Owner's Representative of the situation.
- D. Establish, properly barricade, and mark the area as an exclusion zone under the direction of the SSO. The SSO shall establish the exclusion zone boundaries based upon air quality monitoring using a photoionization detector and other equipment as appropriate. The exclusion zone shall be established at a minimum 50-foot radius around the location where the potentially hazardous material is encountered. Work within the exclusion zone shall be discontinued until the hazardous condition has been remediated and testing indicates that a hazard does not exist. Other activities of the site, outside the limits of the exclusion zone shall continue. Ambient air quality monitoring shall be performed by the SSO to demonstrate that ambient air quality in other portions of the site is not adversely impacted by the exclusion zone condition.
- E. Notify Owner's Representative regarding the presence of potentially hazardous materials. Owner's Representative may direct the Contractor to notify regulators and to obtain necessary regulatory approvals for remediation.
- F. Mobilize the appropriate equipment and personnel to sample and test the hazardous material within the exclusion zone to determine the remedial action required, subject to the Owner's Representative's direction. Contractor may be directed to remove and legally dispose of the material. Compensation for the removal and disposal of hazardous material will be as a Change in Work and Change in Contract Price in accordance with the Subcontract Agreement, if not covered under a specific bid item.

PART 2 - PRODUCTS

2.1 AIR MONITORING EQUIPMENT

- A. Provide and maintain portable photoionization detector or organic vapor analyzer capable of detecting organic vapors or total hydrocarbons. Equipment shall be sensitive to the 0.5 PPM level.

- B. Provide and maintain an oxygen analyzer to measure oxygen concentration in any trench or confined space prior to entry, as determined by the SSO.
- C. Provide and maintain an explosimeter whenever the potential for accumulation of explosive gases exists, as determined by the SSO.
- D. Provide and maintain air monitoring equipment as required for the collection/monitoring of airborne asbestos fibers. All air samples related to abatement work shall be analyzed by a laboratory accredited by the American Industrial Hygiene Association.
- E. All air monitoring equipment shall remain the property of the Contractor.

PART 3 – EXECUTION

NOT USED

****End of Section****

SECTION 014100 - PERMITS AND COMPLIANCE

PART 1 - GENERAL

1.1 GENERAL

- A. Requirements set forth herein are in addition to and shall be considered as complementary to the Conditions of the Contract and the balance of Division #1 and Technical Specifications.
- B. All Contractors, Subcontractors, Sub-subcontractors, Vendors and the like shall be required to familiarize themselves with said provisions.
- C. Definitions as apply to "Contractors" involved with the work of this Project shall be as set forth in Section 011000, Article 1.01.

1.2 REQUIREMENTS INCLUDED IN THIS SECTION

- A. Preconstruction Meeting
- B. Permits and Licenses
- C. Compliance
- D. Additional Compliance

1.3 PRECONSTRUCTION MEETING

- A. After award of Contract and prior to the commencement of the Work, schedule and conduct meeting with Owner and Architect to discuss the applicable environmental regulations and requirements; coordinate with Sections 015713, 015719 and 017419.
- B. For Owner's records, submit copies of permits, licenses, certifications, inspection reports, releases, jurisdictional settlements, notices, receipts for fee payments, judgments, correspondence, records, and similar documents, established for compliance with environmental regulations bearing on performance of the Work.

1.4 PERMITS AND LICENSES

- A. The Contractor shall obtain, maintain and pay for all permits and licenses necessary for the execution of the work and for the use of such work when completed.

1.5 COMPLIANCE

- A. The Contractor shall give all notices, pay all fees and comply with all laws, rules and regulations applicable to the work.

1.6 ADDITIONAL COMPLIANCE

- A. The Contractor, Subcontractors, and the employees of the Contractor and Subcontractors, shall comply with all regulations governing conduct, access to the premises, operation of equipment and systems, and conduct while in or near the premises and shall perform the work in such a manner as not to unreasonably interrupt or interfere with the conduct of business of the Facility.
- B. **Further, attention is directed to requirements of Section 011501.**

13 January 2022
Conformed Specifications
SED #66-23-00-01-0-346-001

Yonkers Joint Schools Construction Board
Community School 35

PART 2 – PRODUCTS

NOT USED

PART 3 – EXECUTION

NOT USED

****End of Section****

SECTION 014219 - CODES AND STANDARDS

PART 1 - GENERAL

1.1 QUALITY ASSURANCE

- A. Applicability of Standards: Unless the Contract Documents include more stringent requirements, applicable construction industry standards have the same force and effect as if bound or copied directly into the Contract Documents to the extent referenced. Such standards are made a part of the Contract Documents by reference.
- B. Publication Dates: Comply with standards in effect as of date of the Contract Documents, unless otherwise indicated.
- C. Conflicting Requirements: Where compliance with two or more standards is specified, and the standards may establish different or conflicting requirements for minimum quantities or quality levels comply with the most stringent requirement. Refer uncertainties and requirements that are different, but apparently equal, to Architect for a decision before proceeding.

1.2 REFERENCE STANDARDS - The abbreviations, which may be used in the construction specifications, refer to the organizations and specifications of the organizations listed below.

AABC	Associated Air Balance Council
AAN	American Association of Nurserymen
AI	Asphalt Institute
AISC	American Institute of Steel Construction
AMCA	Air Movement and Control Association
ARMA	Asphalt Roofing Manufacturers Association
ASC	Adhesive and Sealant Council
ASLA	American Society of Landscape Architects
ASHRAE	American Society of Heating, Refrigerating and Air Conditioning Engineers, Inc.
ASTM	American Society for Testing and Materials International
CLFMI	Chain Link Fence Manufacturers Institute
CRI	Carpet and Rug Institute
GANA	Glass Association of North America
GS	Green Seal
IEEE	Institute of Electrical and Electronics Engineers
IESNA	Illuminating Engineering Society of North America
IGMA	Insulating Glass Manufacturers Alliance
LSGA	Laminators Safety Glass Association
NAIMA	North American Insulation Manufacturers Association
NFPA	National Fire Protection Association
NFRC	National Fenestration Rating Council
NHLA	National Hardwood Lumber Association
NPCA	National Paint and Coatings Association
NPA	National Particleboard Association
NSF	National Sanitation Foundation International
NTMA	The National Terrazzo and Mosaic Association
RFCI	Resilient Floor Covering Institute
SFPA	Southern Forest Products Association

SIGMA	Sealed Insulating Glass Manufacturers Association
SPC	Southern Pine Inspection Bureau (Grading Rules)
SSPC	Steel Structures Painting Council
WDMA	Window & Door Manufacturers Association
WRI	Wire Reinforcement Institute, Inc.
WWPA	Woven Wire Products Association

B. Federal Agencies:

CE	Army Corps of Engineers)
CPC	Consumer Product Safety Commission
EPA	Environmental Protection Agency
DOE	Department of Energy
NIST	National Institute of Standards and Technology
OSHA	Occupational Safety & Health Administration

Further attention is directed to industry guide compiled by Sweet's division of McGraw-Hill denoted as "PROJECT INFORMATION AND SERVICES" as well as in the web site www.4specs.com wherein a comprehensive list of international organizations representing building product manufacturers, associations, institutes, governmental agencies and testing bureaus is put forth.

1.3 APPLICABLE CODES: The following is a listing of applicable codes within the jurisdiction of the Work as embodied within the **2020** New York State Uniform Fire Prevention and Building Code.

- A. *2020 Building Code New York State*
- B. *2020 New York State Energy Conservation Code (includes amendments to ASHRAE 90.1-2016)*
- C. *2020 Plumbing Code of New York State*
- D. *2020 Mechanical Code of New York State*
- E. *2020 Fuel Gas Code of New York State*
- F. *2020 Fire Code of New York State*
- G. *2020 Property Maintenance Code of New York State*
- H. *2020 Residention Code New York State*
- I. Accessibility Code - ANSI A117.1 New York State Building Code
- J. Elevator Code - ASME A17.1-2006 New York State Building Code
- K. Boiler Code - ASME Boiler & Pressure Vessel Code; NBIC
- L. *2020 Existing Building Code New York State*

****End of Section****

SECTION 014326 - TESTING LABORATORY SERVICES

1.1 GENERAL

- A. Requirements set forth herein are in addition to and shall be considered as complementary to the Conditions of the Contract and the balance of Division #1 and Technical Specifications.
- B. All Contractors, Subcontractors, Sub-subcontractors, Vendors and the like shall be required to familiarize themselves with said provisions.
- C. Definitions as apply to "Contractors" involved with the work of this Project shall be as set forth in Section 011000, Article 1.01.
- D. Pursuant to the provisions of Section 013300, Submittal Requirements, it is further required that unless otherwise specified, tests called for in the Specifications applicable to the work and/or required to implement the work shall be paid for by the Owner.
- E. Where tests are required by the Architect to substantiate conformance to the specifications the Owner will pay all costs of such tests and engineering services unless said tests indicate that the workmanship or materials used by the Contractor are not in conformance with the Drawings, Specifications, Approved Shop Drawings or the approved materials.

In such event, the Contractor shall pay for the tests, remove all work and material so failing to conform, REPLACE with work and materials which are in full conformity.

- F. Requirements related to testing services and specified elsewhere in these documents include:
 - 1. Inspections and testing as required by laws, ordinances, rules, regulations or orders of public authorities having jurisdiction over the work.
 - 2. Certification of compliance as required by individual specification sections.
 - 3. Testing, adjusting and balancing of mechanical equipment and systems.
 - 4. Project record documents, including operation and maintenance manuals, record drawings and the like.
 - 5. Tests and standards governing work and/or materials as may be specified throughout these specifications and/or as shown on the drawings.
- G. The Owner will employ, and pay for, the services of an Independent Testing Laboratory to perform all specified services.
- H. Inspection, sampling and testing is required for the following as applicable to the particular project:
 - Concrete, formwork, reinforcing and the like.
 - Masonry and mortar.
 - Roofing and flashing systems
 - Structural steel systems, joists, decking, light metal framing and the like.
 - Weldinghowever this listing is to be considered as partial only with the burden placed on the Contractor to advise, and the Laboratory to provide, all such inspections, sampling and testing as may be specified and/or required by these Contract Documents and the applicable laws and ordinances of the jurisdiction.
- I. Employment of the Testing Laboratory shall not relieve the Contractor of his obligation to perform Work in accordance with the Contract.

1.2 REQUIREMENTS INCLUDED IN THIS SECTION

- A. Laboratory Qualifications
- B. Laboratory Duties
- C. Contractor's Responsibilities
- D. Tests Required

1.3 LABORATORY QUALIFICATIONS

- A. Laboratory shall meet -
 - 1. The "Recommended Requirements for Independent Laboratory Qualifications", latest edition as published by the American Council of Independent Laboratories.
 - 2. Basic requirements of ASTM E 329, latest edition, governing "Standards of Recommended Practice for Inspection and Testing Agencies for Concrete and Steel as Used in Construction".
- B. Laboratory shall submit copy of inspection of facilities as made by Materials Reference Laboratory of the National Bureau of Standards during most recent tour of inspection; with memorandum of remedies of any deficiencies reported by inspection.
- C. Testing equipment shall be calibrated at maximum 12 month intervals by devices of accuracy traceable to either - National Bureau of Standards or accepted values of natural physical constants; submit copy of certificate of calibration as executed by an accredited calibration agency.

1.4 LABORATORY DUTIES

- A. Cooperate with Architect and Contractor; provide qualified personnel promptly on notice.
- B. Perform specified inspections, sampling and testing of materials and methods of construction in conformance with specified standards, recognized authorities and the like so as to ascertain compliance with the requirements of the Contract Documents.
- C. Promptly notify Architect and Contractor of irregularities or deficiencies of Work which are observed during performance of services.
- D. Promptly submit sufficient copies (minimum 5) of reports and tests to Architect for distribution. Reports shall contain -
 - 1. Issue date
 - 2. Project title and number
 - 3. Testing laboratory name and address
 - 4. Name and signature of inspector
 - 5. Date of inspection or sampling
 - 6. Temperature and weather observations
 - 7. Test date
 - 8. Identification of product and specification section
 - 9. Location in project
 - 10. Type of inspection or test
 - 11. Observations regarding Contract Document compliance.
- E. Perform additional services as required by the Owner and/or Architect.
- F. The laboratory is not authorized to - release, revoke, alter or enlarge on, requirements of the Contract Documents; approve or accept any portion of Work; perform any duties of the Contractor.

1.5 CONTRACTOR'S RESPONSIBILITIES

- A. The Contractor shall to the best of his ability -
 - 1. Cooperate with laboratory personnel, provide access to the Work and to Manufacturer's operations as may be necessary.
 - 2. Provide to the laboratory preliminary representative samples of materials to be tested in required quantities.
 - 3. Furnish copies of mill test reports.
 - 4. Provide casual labor and facilities as required to provide access to Work to be tested; to obtain and handle samples at the Site; to facilitate inspections and tests; for laboratory's exclusive use for storage and curing of test samples.
 - 5. Notify laboratory sufficiently in advance of operations to allow for his assignment of personnel and scheduling of tests.
 - 6. Arrange with laboratory and PAY FOR, additional sampling and testing required for the Contractor's convenience.
 - 7. Employ, AND PAY FOR, services of a separate, equally qualified Independent Testing Laboratory to perform additional inspections, sampling and testing required when initial tests indicate Work does not comply with Contract Documents. Coordinate with Paragraph 1.05.A.4 above.

1.6 TESTS REQUIRED

- A. General Construction Tests: More detailed testing requirements are given in individual Specification Sections. The Owner shall retain the right to make any additional tests the Architect deem necessary or appropriate. The Contractor is responsible for providing his own tests to determine that materials meet specified requirements. The scope of tests required and paid for by the Owner (unless otherwise noted below) shall include as a minimum the following:
 - 1. Concrete Paving and General Concrete Work: Concrete mix design testing shall be paid for by Contractor. Owner reserves the right to retain and pay for his own testing for checking purposes.
 - 2. Concrete Paving and General Concrete Work: Concrete test cylinders as specified in Section 03 30 00, Cast-in-Place Concrete. All concrete cylinder testing will be performed by the Owner's testing laboratory at the cost of the Owner.
 - 5. Masonry Mortar: Three cubes tested for compressive strength at 10 days; ASTM C 91 tests.
 - 6. Metals: Strength dimension; coating thickness; bolt torque; welding X-ray or ultrasonic tests.
- B. Plumbing: At least the following tests will be performed. Conform to requirements specified in individual Division 22 Specification Sections. The test shall be performed and paid for by the subcontractor and witnessed by the Contractor and Owner's on-site representative:
 - 1. Water supply piping hydrostatic pressure test.
 - 2. Sanitary piping test before fixture installation: Cap pipes and fill to highest point in system.
 - 3. Plumbing fixture operation.
- C. Fire Protection System: At least the following tests will be performed. Conform to requirements specified in individual Division 21 Specification Sections. The test shall be performed and paid for by the subcontractor and witnessed by the Contractor and Owner's on-site representative:
 - 1. Fire protection system flushed and pressure tested.

- D. HVAC Testing: All HVAC work shall be tested by an independent testing and balancing agency. Conform to requirements specified in individual Division 23 Specification Sections. All costs of these tests will be paid by the subcontractor. Adjustments shall be made by the subcontractor as directed by the Owner. At least the following tests will be performed:
 - 1. Piping hydrostatic tests.
 - 2. Air and water balancing.
 - 3. Thermostat control monitoring and testing.
 - 4. Boiler efficiency testing.
- E. Electrical Power System Testing: At least the following tests will be performed. Conform to requirements specified in individual Division 26 Specification Sections. The test shall be performed and paid for by the subcontractor and witnessed by the Contractor and Owner's on-site representative:
 - 1. Polarity tests.
 - 2. Operation of all circuits.
 - 3. Testing of emergency system.
 - 4. Security systems.
 - 5. Generation system.
 - 6. Grounding systems.
- F. Electrical Lighting System Testing: Conform to requirements specified in individual Division 26 Specification Sections. At least the following tests shall be performed and paid for by the subcontractor.
 - 1. Operation of every component of entire system.
- G. Fire Alarm System Testing: At least the following tests will be performed. Conform to requirements specified in individual Division 28 Specification Sections. The test shall be performed and paid for by the subcontractor and witnessed by the Contractor and Owner's on-site representative:
 - 1. All smoke and heat detectors.
 - 2. Proper operation as required by authorities having jurisdiction.
- H. Contractor's Responsibilities: The Contractor shall notify the Owner, Architect, and Testing Laboratory personnel at least 48 hours prior to performance of work requiring testing. The Contractor shall fully cooperate with testing agencies and permit free access to all areas at all times. The Contractor shall permit taking samples at any time during construction, either before or after installation. Prior to notice to proceed with construction, the Contractor shall submit a Testing Log of planned tests and scheduled test dates. Tests shall be numbered based on type of work, type of test, and sequence. The Testing Log shall be maintained by the Contractor and updated weekly.
 - 1. Coordination: The Contractor shall coordinate all testing, including all testing and inspections to be paid for by the Owner. The Contractor will arrange testing and sampling performed by the Owner's testing agency and will have prepared test record forms. Upon receipt of test results, the Owner will distribute 2 copies to the Contractor and 2 copies to the Architect with test results.
- I. Follow-up and Corrective Action: The Contractor and the Owner will note the test record on the Testing Log to acknowledge test procedures and results. If the follow-up or corrective action is needed, the Contractor shall submit to the Owner 2 written copies of proposed follow-up or corrective plans and obtain the Owner's written approval before proceeding.
 - 1. Cost of Testing: If tests indicate that materials or work do not comply with

requirements, the contractor shall pay for all retesting, and shall remove and replace non-complying work at no additional cost to the Owner.

- J. Local Owner Inspections: The Contractor is also responsible for coordinating and cooperating with local requirements for inspections.

****End of Section****

THIS PAGE INTENTIONALLY LEFT BLANK

 NYS EDUCATION DEPARTMENT Office of Facilities Planning 89 Washington Avenue, Room 1060 EBA Albany, NY 12234		STATEMENT OF SPECIAL INSPECTIONS AND TESTS As required by the Building Code of NYS (BCNYS)	
BCNYS § 1704.1.1 requires the project Design Professional to complete the Statement of Special Inspections and Tests. Completion of the Statement of Special Inspections & Tests and submission to the Office of Facilities Planning with the Construction Permit Application is a condition for issuance of the Building Permit.			
School District Yonkers Public Schools		Building New Community School	
Project Title New Community School Construction			
SED Project # 66-23-00-01-0-346-001		Project Address 121 McLean Ave. Yonkers, NY 10705	
Architect/Engineer The DiSalvo Engineering Group /Insite Designs - Engineering/ KG+D Architect			
Name of Person Completing this Statement Trevor B. Hill		Phone 203-490-4140	Date 6/22/2021
Comments			

INSPECTION AND TESTING (Continuous & Periodic is as Defined by the BCNYS)	CONTINUOUS	PERIODIC	REFERENCE STANDARD	BCNYS REFERENCE	CHECK IF REQUIRED	IDENTIFY SPEC SECTION AND PROVIDE CLARIFYING NOTES IF NECESSARY
A. Steel Construction						
1. Material verification of high-strength bolts, nuts and washers.		X	Applicable ASTM material specifications. AISC 360, Section A3.3	1705.2	<input checked="" type="checkbox"/>	51200
2. Inspection of high-strength bolting.	X	X	AISC 360, Section M5.6-3	1705.2	<input checked="" type="checkbox"/>	51200
3. Material verification of structural steel.			AISC360 Ch. N	1705.2	<input checked="" type="checkbox"/>	51200
4. Material verification of weld filler materials.			AISC 360, Ch. N	1705.2	<input checked="" type="checkbox"/>	51200
5. Inspection of welding:				1705.2	<input type="checkbox"/>	
a. Structural steel	X	X	AISC360 Table N5.4-1	1705.2	<input checked="" type="checkbox"/>	51200
b. Reinforcing steel	X	X	AISC360 Table N5.4-1	1705.2	<input type="checkbox"/>	
6. Inspection of steel frame joint details.		X	AISC360 Table N6.1	1704.3, 1704.3.2	<input checked="" type="checkbox"/>	51200
B. Concrete Construction						
1. Inspection of reinforcing steel, including prestressing tendons, and placement.		X	ACI 318: 20,25.2, 25.3, 26.6.1-26.6.3	175.3 1908.4	<input checked="" type="checkbox"/>	51200
2. Inspection of reinforcing steel welding.			AWS D1.4; ACI 318: 26.6.4	1704.4	<input type="checkbox"/>	

INSPECTION AND TESTING (Continuous & Periodic is as Defined by the BCNYS)	CONTINUOUS	PERIODIC	REFERENCE STANDARD	BCNYS REFERENCE	CHECK IF REQUIRED	IDENTIFY SPEC SECTION AND PROVIDE CLARIFYING NOTES IF NECESSARY	
3. Inspection of bolts to be installed in concrete prior to and during placement.	X		Ch. N: Section N5.6 and Tables N5.6-1, N5.6-2 and N5.6-3	1705.3	<input checked="" type="checkbox"/>	33000	
4. Verify use of required design mix.		X	ACI 318: Ch. 19,26.4.3,26.4.4	1904.1 1904.2 1908.2 1908.3	<input checked="" type="checkbox"/>	33000	
5. Sampling fresh concrete: slump, air content, temperature, strength test specimens.	X		ASTM C 172, C 31; ACI 318: 5.6, 5.8	1908.9	<input checked="" type="checkbox"/>	33000	
6. Inspection of placement for proper application techniques.	X		ACI, 318: 26.5	1904.1 1904.2 1908.2 1908.3	<input checked="" type="checkbox"/>	33000	
7. Inspection for maintenance of specified curing temperature and techniques.		X	ACI, 318: 26.5.3-26.5.5	1908.9	<input checked="" type="checkbox"/>	33000	
8. Inspection of prestressed concrete.	X		ACI 318: 18.18.4, 18.20	1705.2	<input type="checkbox"/>		
9. Erection of precast concrete members.		X	ACI 318: Ch. 26.8	1705.3	<input type="checkbox"/>		
10. Verification of in-situ concrete strength prior to stressing of tendons and prior to removal of shores and forms from beams and slabs.		X	ACI 318:26.11.2	1705.3	<input type="checkbox"/>		
11. Inspection of formwork		X	ACI 318: 26.11.2	1705.3	<input checked="" type="checkbox"/>	33000	
C. Masonry Construction							
L1 = Level 1 Inspection required for nonessential facilities.			ACI 530/ ASCE 5/TMS 402, Ch. 35	ACI 530.1/ ASCE 6/TMS 602, Ch.	1705.4	<input checked="" type="checkbox"/>	42000
L2 = Level 2 Inspection required for essential facilities. In general, schools are not considered essential facilities unless they are a designated emergency shelter			ACI 530/ ASCE 5/TMS 402, Ch. 35	ACI 530.1/ ASCE 6/TMS 602, Ch. 35	1705.4	<input type="checkbox"/>	

INSPECTION AND TESTING (Continuous & Periodic is as Defined by the BCNYS)	CONTINUOUS	PERIODIC	REFERENCE STANDARD		BCNYS REFERENCE	CHECK IF REQUIRED	IDENTIFY SPEC SECTION AND PROVIDE CLARIFYING NOTES IF NECESSARY
1. Verify to ensure compliance:							
a. Proportions of site prepared mortar and grout.		L1 & L2	Table 3.1.2.2.a. Table 3.1.2.3.d.	2.1, 2.6A, 2.6B	1705.4	<input checked="" type="checkbox"/>	42000
b. Placement of masonry units and construction of mortar joints.		L1 & L2	Table 3.1.2.4.a	3.3F	1705.4	<input checked="" type="checkbox"/>	42000
c. Location and placement of reinforcement, connectors, tendons, anchorages.		L1 L2	Section 1.13 Table 3.1.2.2.d.; Table 3.1.2.3.c. Sec. 1.13	3.2E, 3.4 3.4, 3.6A	7105.4 7105.4	<input checked="" type="checkbox"/> <input type="checkbox"/>	42000
d. Prestressing technique. Grout space prior to grouting.	L2	L1			7105.4 1705.4	<input type="checkbox"/> <input type="checkbox"/>	
e. Grade and size of prestressing tendons and anchorages. Placement of grout.	L2	L1			7105.4 7105.4	<input type="checkbox"/> <input type="checkbox"/>	
f. Grout specs prior to grouting.	L2				7105.4	<input checked="" type="checkbox"/>	42000
2. Inspection program shall verify:							
a. Size and location of structural elements.		L1 & L2		3.3F	1705.4	<input checked="" type="checkbox"/>	42000
b. Type, size, and location of anchors.	L2	L1	Sec. 1.2.2(e), 2.1.4, 3.1.6		1705.4	<input checked="" type="checkbox"/>	42000
c. Specified size, grade, and type of reinforcement.		L1 & L2	Sec. 1.13	2.4, 3.4	1705.4	<input checked="" type="checkbox"/>	42000
d. Welding of reinforcing bars.	L1 & L2		2.1.7.10.2, 3.3.3.4(b)		7105.4	<input type="checkbox"/>	
e. Cold/hot weather protection of masonry construction.		L1 & L2	Table 3.1.2.4.d	1.8C, 1.8D	1705.4	<input checked="" type="checkbox"/>	42000
f. Prestressing force measurement and application.	L2	L1		3.6B	7105.4	<input type="checkbox"/>	
3. Verification prior to grouting.	L2	L1	1.13	3.2D, 3.4, 2.6B, 3.3B 1.4	1704.5 1704.5 2105.2.2, 2105.3	<input checked="" type="checkbox"/> <input type="checkbox"/>	42000
4. Grout placement.	L1		Table 3.1.2.3.a Table 3.1.2.1.f	3.2D, 3.2F, 3.5	1705.4	<input checked="" type="checkbox"/>	42000

INSPECTION AND TESTING (Continuous & Periodic is as Defined by the BCNYS)	CONTINUOUS	PERIODIC	REFERENCE STANDARD		BCNYS REFERENCE	CHECK IF REQUIRED	IDENTIFY SPEC SECTION AND PROVIDE CLARIFYING NOTES IF NECESSARY
5. Preparation of grout specimens, mortar specimens, and/or prisms.	L1 & L2				1705.2	<input type="checkbox"/>	
6. Compliance with documents and submittals.		L1 & L2	Table 3.1.2.4.a	3.3F	1705.4	<input type="checkbox"/>	
D. Wood Construction							
1. Fabrication process of prefabricated wood structural elements and assemblies.				1704.2.5		<input type="checkbox"/>	
2. High-load diaphragms designed in accordance with Table 2306.3.2			Table 2306.2	1705.5		<input type="checkbox"/>	
E. Soils					1705.6	<input checked="" type="checkbox"/>	
F. Pile Foundations					1705.7	<input type="checkbox"/>	
G. Pier Foundations					1705.8	<input type="checkbox"/>	
H. Sprayed Fire-Resistant Materials							
1. Structural member surface conditions.				1705.14.2		<input checked="" type="checkbox"/>	78100
2. Application.				1705.14.3		<input checked="" type="checkbox"/>	78100
3. Thickness.			ASTM E 605	1705.14.4		<input checked="" type="checkbox"/>	78100
4. Density.			ASTM E 605	0705.14.5		<input checked="" type="checkbox"/>	78100
5. Bond strength.			ASTM E 736	1705.14.6		<input checked="" type="checkbox"/>	78100
I. Mastic and Intumescent Fire-Resistant Coatings					1705.15	<input checked="" type="checkbox"/>	78123
J. Exterior Insulation and Finish Systems (EIFS)					1705.16	<input type="checkbox"/>	
K. Special Cases					1705.17	<input type="checkbox"/>	
L. Smoke Control					1705.18	<input type="checkbox"/>	
M. Special Inspections for Seismic Resistance							
1. Structural steel.	X		AISC 341	1705.12.1		<input type="checkbox"/>	
2. Structural wood.	X			1705.12.2		<input type="checkbox"/>	
3. Cold-formed steel framing.		X		1705.12.3		<input type="checkbox"/>	
4. Pier Foundations.		X		1705.8,1705.12		<input type="checkbox"/>	
5. Storage racks and access floors.		X		1705.12.5, 1705.12.7		<input type="checkbox"/>	

INSPECTION AND TESTING (Continuous & Periodic is as Defined by the BCNYS)	CONTINUOUS	PERIODIC	REFERENCE STANDARD	BCNYS REFERENCE	CHECK IF REQUIRED	IDENTIFY SPEC SECTION AND PROVIDE CLARIFYING NOTES IF NECESSARY
6. Architectural components.		X		1705.12.5	<input type="checkbox"/>	
7. Mechanical and electrical components.		X		1705.12.6	<input type="checkbox"/>	
8. Designated seismic system verifications				1705.13.3	<input type="checkbox"/>	
9. Seismic isolation system.		X		1705.13.4	<input type="checkbox"/>	
N. Structural Testing for Seismic Resistance						
1. Testing and verification of masonry materials and assemblies prior to construction.				1705.13.2	<input type="checkbox"/>	
2. Testing for seismic resistance.				1705.13	<input type="checkbox"/>	
3. Reinforcing and prestressing steel.			ACI 318	1705.13	<input type="checkbox"/>	
4. Structural steel.			AISC 341, AWS D1.1	1705.13	<input type="checkbox"/>	
5. Seismic qualification of mechanical and electrical equipment.				1705	<input type="checkbox"/>	
6. Seismically isolated structures.			Section 17.8 of ASCE 7	1705.13.4	<input type="checkbox"/>	
O. Structural Observations						
1. Seismic resistance.				1704.6	<input type="checkbox"/>	
2. Wind requirements.				1704.6	<input type="checkbox"/>	
P. Test Safe Load				1707	<input type="checkbox"/>	
Q. In-Situ Load Tests				1708	<input type="checkbox"/>	
R. Preconstruction Load Tests				1709	<input type="checkbox"/>	
S. Other (list)					<input type="checkbox"/>	

SECTION 014339 - MOCKUP REQUIREMENTS

1.1 GENERAL

- A. Requirements set forth herein are in addition to and shall be considered as complementary to the Conditions of the Contract and the balance of Division #1 and Technical Specifications.
- B. All Contractors, Subcontractors, Sub-subcontractors, Vendors and the like shall be required to familiarize themselves with said provisions.
- C. Definitions as apply to "Contractors" involved with the work of this Project shall be as set forth in Section 011000, Article 1.01.

1.2 REQUIREMENTS INCLUDED IN THIS SECTION

- A. General Purpose of Mockups
- B. Miscellaneous Mockups

1.3 GENERAL PURPOSE OF MOCKUPS

- A. Contractors are advised that various sections of the Specifications require construction of mockups. Where mockups are required the Contractor erecting the mockup shall notify the Architect one week prior to its completion.
- B. The purpose of each mockup will be to establish minimum standards of materials and workmanship and to assure that completed installations based on the mockups will be fully functional and will serve the purpose for which they have been designed.
- C. Approved mockups may be left in place and incorporated into the permanent installation.
- D. The Contractor shall not proceed with the purchase or fabrication of any "mockup" items until the procedure of mockup erection, inspection and approval is completed and documented.
- E. Contractor shall coordinate work at each mockup with other trades construction that mockup.

1.4 MISCELLANEOUS MOCKUPS

- A. Field mockups for work are required as noted within the technical specifications and generally include work identified within said sections.

Failure to list any required mockup will not relieve the Contractor from executing said mockup.

****End of Section****

THIS PAGE INTENTIONALLY LEFT BLANK

1.1 GENERAL

- A. Requirements set forth herein are in addition to and shall be considered as complementary to the Conditions of the Contract and the balance of Division #1 and Technical Specifications.
- B. In general this Section includes requirements for construction facilities and temporary controls, including temporary utilities, support facilities, and security and protection.
- C. All Contractors, Subcontractors, Sub-subcontractors, Vendors and the like shall be required to familiarize themselves with said provisions.
- D. Provide environmental protection as required by authorities having jurisdiction and as indicated in the Contract Documents.

1.2 REQUIREMENTS INCLUDED IN THIS SECTION

- A. Field Office
- B. Temporary and Permanent Services, General
- C. Temporary Light and Power
- D. Temporary Heating/Cooling Facilities
- E. Temporary Toilet Facilities
- F. Temporary Water
- G. Storage Facilities
- H. Scaffolding and Staging
- I. Construction Fencing and Barriers – See drawings for scope of work; interior barriers shall be constructed of steel studs and fire rated gypsum with level 1 tape finish. Fire safe all temporary partitions.
- J. Janitorial Service/Daily Cleanup
- K. Burning
- L. Dust Control
- M. Fire Prevention Control
- N. Temporary Fire Protection
- O. Discontinuance, Changes and Removal

1.3 FIELD OFFICE

- A. The Contractor, until all work covered by the Contract is accepted by the Owner, will be assigned an area or areas within the existing building to be used as an office for his use, and use of the Architect, Owner and their representatives and shall equip same with furniture, files and accessories as necessary to service the project; coordinate requirements for Architect and Owner with said parties.
- B. Contractor shall provide telephone service for all calls.
- C. The Contractor shall provide daily housekeeping for all office spaces.
- D. Maintain, in the Contractor's field office, all articles necessary for First Aid treatment; further, the Contractor shall establish standing arrangements for the immediate removal and hospital treatment of any employees and other persons on the job site who may be injured or who may become ill during the course of the work.

1.4 TEMPORARY AND PERMANENT SERVICES, GENERAL

- A. The Contractor shall provide and maintain, either directly or through its' subcontractors, all temporary services and utilities, including all labor, materials, equipment and the like necessary to adequately furnish, deliver and maintain said services at all times when required during the term of the Contract.
- B. Temporary work shall generally include, but not be limited to - temporary light and power; temporary heat; temporary toilets; temporary water; hoisting systems; rubbish chutes; temporary stairs, rails and shaft protection; storage; temporary fences; roof protection; temporary enclosures and the like required to conduct the work in a proper manner.
- C. The Contractor's use of any permanent system or service of the building or portions thereof shall be subject to the Owner's approval.
- D. The Contractor shall be responsible for any and all damage to permanent services used, and shall make good any and all damage to the satisfaction of the Owner, prior to final completion and acceptance.

1.5 TEMPORARY LIGHT AND POWER

- A. The energy will be supplied, **and paid for**, by the Owner for all work within the present building. Abuse of service will be cause for termination of service. No reimbursement will be made by Owner in the event of disconnect.
- B. Where feasible locations for temporary power shall be from the nearest adequate duplex or simplex outlet to the work of this Contract.
- C. Because of the high concentration of computers within the building, electrically powered welding equipment shall not be connected to the Owner's wiring system. Self-generated welding equipment shall be used. It shall be the responsibility of the General Contractor that any electric welding equipment used on the project will not have any harmful effect on existing computers, computer storage systems or other computer equipment.

1.6 TEMPORARY HEATING/COOLING FACILITIES

- A. The Contractor shall provide and pay for all temporary heating, coverings and enclosures necessary to properly protect all work and materials against damage by dampness and cold, to dry out the work and to facilitate the completion thereof. The Contractor shall maintain the critical installation temperatures, provided in the technical provisions of the specifications, herein, for all work in those areas where same is being performed.

Attention is directed to specific temperature requirements for painting, carpentry, flooring and such other temperature sensitive operations connected with the execution of the Work.

- B. Before and during the placing of wood finish and the application of other interior finishing, varnishing, painting, etc. and until final acceptance by the Owner of all work covered by the Contract, the Contractor shall, unless otherwise specified in the Contract Documents, maintain a temperature of between 65 and 85 degrees F. Coordinate with Division 9 of the Technical Specifications.

1.7 TEMPORARY TOILET FACILITIES

- A. The General Contractor will be required to provide a central restroom trailer (toilets and handwashing sinks) with connections to municipal water and sewer services and electric service. Free-standing, self-contained, portable toilets are not to be installed on this project, except as may be needed by regulation to supplement the central restroom trailer facilities.
- B. Provide Restroom Trailer approximately 8.5'x30' for use by the personnel engaged in construction activities for the duration of the contract. Contractor needs to maintain and service the trailer including regular cleaning and all supplies. The trailer location will be as directed by the Owner and CM.
- C. All maintenance and restoration of facilities is the responsibility of the General Contractor upon completion at no cost to the Owner.
- D. Restroom Trailer shall be in place and functional at the beginning of construction from the end of demolition under a separate contract

1.8 TEMPORARY WATER

- A. The Owner will provide water service to the Contractor without charge, but reserves the right to terminate, without incurring additional cost, said service in the event of abuse of such service.
- B. The Contractor shall make all necessary connections and extend piping to areas required at no additional cost to the Owner.
- C. The Contractor shall have all equipment for the temporary water removed at the completion of the Project or when directed by the Architect or Owner.

1.9 STORAGE FACILITIES

- A. The Contractor shall provide tool houses and other facilities as required for his own use.
- B. Materials delivered to the site shall be safely stored and adequately protected against loss or damage. Particular care shall be taken to protect and cover materials that are liable to be damaged by the elements.
- C. Due to limited on site storage space, the Contractor shall coordinate delivery of materials, determine when large deliveries shall be made and designate storage locations on site for delivered materials.

1.10 SCAFFOLDING AND STAGING

- A. All scaffold, staging and appurtenances thereto shall comply in total to the requirements of Safety and Health Regulations for Construction Chapter XVII of OSHA, Part 1926 and all related amendments.

1.11 RUBBISH CONTAINER

- A. Provide suitable rubbish container device (s), properly maintained and serviced, replaced as required and protected from access by the public by fencing as may be specified herein or approved by the Architect.

1.12 JANITORIAL SERVICE/DAILY CLEANUP

- A. The Contractor shall furnish daily janitorial services for the project and perform any required maintenance of facilities as deemed necessary by the Architect during the entire life of the contract.

Toilet facilities shall be kept clean and sanitary at all times. Services shall be accomplished to the satisfaction of the Architect.

The Contractor shall provide daily trash collection and cleanup of the project area and shall dispose of all discarded debris, and the like in a manner approved by the Architect.

- B. The Contractor shall place foot wiping carpet at all entrances, exits to the work areas and provide daily cleaning for all dust and footprints from the corridors, stairs, and the like, caused by construction.
- C. The General Contractor will take full responsibility of the Temporary Toilet Trailer that is currently on the site as part of the Demolition Project (8-Station restroom: The Neptune by CALLAHEAD). To supplement, The General Contractor will be required to provide an additional free-standing, self-contained central restroom trailer (toilets and handwashing sinks) similar to what is already on site.
- D. Provide restroom trailer (Similar to The Neptune by CALLAHEAD) additionally as needed for OSHA requirements, for use by the personnel engaged in construction activities for the duration of the contract. Contractor needs to maintain and service the trailer(s) including regular cleaning and all supplies. The trailer location(s) will be as directed by the Owner and CM.
- E. All maintenance and restoration of facilities is the responsibility of the General Contractor upon completion at no cost to the Owner.
- F. Restroom Trailer shall be in place and functional at the beginning of construction from the end of the demolition work (under a separate contract).

1.13 BURNING: Burning will not be permitted.

1.14 DUST CONTROL: The Contractor shall, at all times, provide adequate dust control measures. He shall accomplish this without interference with the operations of the Owner or the safe progress of the work.

1.15 FIRE PREVENTION CONTROL

- A. All Contractors shall comply with the safety provisions of the National Fire Protection Association's "National Fire Codes" pertaining to the work and, particularly, in connection with any cutting or welding performed as part of the work.

1.16 TEMPORARY FIRE PROTECTION

- A. Each Contractor shall take all possible precautions for the prevention of fires. Where flame cutting torches, blow torches, or welding tools are required to be used within the building, their use shall be as approved by the Architect at the site.

When welding tools or torches of any type are in use, have available in the immediate vicinity of the work a fire extinguisher of the dry chemical 20 lbs. type. The fire extinguisher (s) shall be provided and maintained by the Contractor doing such work.

- B. Fuel for cutting and heating torches shall be gas only and shall be contained in Underwriter's laboratory approved containers. Storage of gas shall be in locations as approved by the Owner and subject to Fire Department regulations and requirements.
- C. No volatile liquids shall be used for cleaning agents or as fuels for motorized equipment or tools within a building except with the express approval of the Owner and/or Architect and in accordance with local codes. On-site bulk storage of volatile liquids shall be outside the buildings at locations directed by the Owner, who shall determine the extent of volatile liquid allowed within the building at any given time.
- D. The Contractor shall comply with the following requirements relating to compressed gas:
 - 1. Where compressed gas of any type is used for any purpose at the site, it shall be contained in cylinders complying with ICC regulations. Gases of different types shall not be stored together except when in use and when such proximity is required.
 - 2. All gas cylinders shall be stored in sheds constructed of noncombustible materials. Sheds shall be well ventilated and without electric lights or fixtures and shall be located as far from other buildings as is practicable. All gas cylinders not in actual use, or in proposed immediate use, shall be removed from the building under construction or reconstruction. Empty gas cylinders shall be removed prior to bringing in a replacement cylinder. Cylinders shall at all times be supported and braced in an upright position. When not in use, the protective cap shall be screwed over the valve.
 - 3. All persons required to handle gas cylinders or to act as temporary firemen (Fire Watchers) shall be able to read, write and understand the English language; they shall also be required by the Contractor to read Part 3 of Pamphlet P-1 "Safe Handling of Compressed Gases" published by the Compressed Gas Association, 500 Fifth Avenue, New York, NY 10036.
 - 4. Where LP-Gas is required for Temporary Heat (including Construction Heat), the number of the cylinders within the structure or building shall be limited to the least amount required; in general, one (1) cylinder per heater. Cylinders and heaters shall be connected with two (2) braid neoprene hoses fitted at each end with threaded unions and capable of withstanding a pressure of 250 P.S.I. The length of those shall not exceed 30 feet and shall be protected from mechanical injury, kinking and abrasion. Heaters shall not be less than 6 feet from any cylinder and not less 10 feet from any tarpaulins or type closure. All debris and rubbish shall be removed to prevent fire hazards.
 - 5. Where local ordinances are in effect regarding gas cylinders, (their use, appurtenances and handling), such ordinances shall supplement the requirements of this paragraph. All personnel engaged in firewatch shall be certified by the Local Fire Department having jurisdiction.
 - 6. LP-Gas Heating will not be permitted in enclosed areas below grade.
 - 7. Any cylinder not having the proper ICC markings or reinspection marking, or any cylinder with a leak shall be isolated immediately away from any building and the supplier shall be immediately notified; such other

precautions as may be required to prevent damage or injury shall also be taken by the Contractor.

- E. The Contractor shall comply with the following requirements relating to welding and cutting:
1. All cutting and/or welding (electric or gas) must be done only by skilled, certified and licensed personnel.
 2. During welding or cutting operations, a contractor's man shall act as a fire watcher. The fire watcher shall have proper eye protection and suitable firefighting equipment including fire extinguisher (bearing current inspection Certificate), protective gloves and any other equipment deemed necessary.
 3. Welding or cutting shall not be done near flammable liquid, vapors or tanks containing such material.
 4. Where cutting or welding is done above or adjacent to (within two feet) combustible material or persons, a shield of incombustible material shall be installed to protect against fire or injury to sparks or hot metal.
 5. Tanks supplying gases for welding or cutting are to be placed in an upright position securely fastened, and as close as practical to the operation. Tanks, actives or spares, shall be protected from excess heat and shall not be placed in stairways, hallways or exits. When not in use, protective valve cap shall be screwed on the cylinder.
 6. Adequate fire extinguishing equipment shall be maintained at all welding or cutting operations.
 7. The Contractor shall secure all required inspections.
 8. All equipment, hoses, gauges, pressure reducing valves, torches, etc., shall be maintained in good working order and all defective equipment shall immediately be removed from the job.
 9. No person shall be permitted to do any welding or cutting until his name, address and current license number have been submitted in writing to the Owner.
- F. Contractors for work outside the building shall commence operations promptly on award of Contract, and shall be responsible for same being kept clear of materials and debris in connection with their own work and that of other Contractors. If a Contractor for outside work allows other contractors to deposit material and debris over its lines, the Contractor shall be responsible for all delay and extra cost occasioned thereby.

1.17 DISCONTINUANCE, CHANGES AND REMOVAL

- A. All Contractors shall:
1. Discontinue all temporary services required by the Contract when so directed by the Owner or the Architect.
 2. The discontinuance of any such temporary service prior to the completion of the work shall not render the Owner liable for any additional cost entailed thereby and each Contractor shall thereafter furnish, at no additional cost to the Owner, any and all temporary service required by such Contractor's work.
 3. Remove and relocate such temporary facilities as directed by the Owner or the Architect without additional cost to the Owner, and shall restore the site and the work to a condition satisfactory to the Owner.

13 January 2022
Board
Conformed Specifications
35
SED #66-23-00-01-0-346-001

Yonkers Joint Schools Construction

Community School

****End of Section****

SECTION 015713 - TEMPORARY EROSION AND SEDIMENT CONTROL

PART 1 - GENERAL

1.1 GENERAL

- A. Requirements set forth herein are in addition to and shall be considered as complementary to the Conditions of the Contract and the balance of Division #1 and Technical Specifications.
- B. All Contractors, Subcontractors, Sub-subcontractors, Vendors and the like shall be required to familiarize themselves with said provisions.
- C. Definitions as apply to "Contractors" involved with the work of this Project shall be as set forth in Section 01 10 00, Article 1.01.

1.2 RESPONSIBILITY

- A. Assume responsibility for the temporary control of soil erosion and water pollution resulting from performance of the work of this contract.
- B. In the event of conflict between these specifications and the regulation of other Federal, State, or local jurisdictions, the more restrictive regulations shall apply.
- C. The Contractor shall engage services of a Certified Professional in Erosion and Sediment Control (CPESC), a licensed Professional Engineer or a licensed Landscape Architect to conduct regular inspections at least once every seven calendar days and within 24 hours after each storm producing 0.5 inches of rainfall or greater.

1.3 DESCRIPTION

- A. The Work shall consist of temporary control measures as required to provide temporary control of soil erosion or water pollution and work in conjunction with technical specifications, specifically:
 - 1. Site Preparation and Protection (31 10 00)
 - 2. Earthwork (31 23 00)
 - 3. Lawns and Grasses (32 92 00)
- B. Temporary measures shall include silt fences, inlet protections, berms, sedimentation basins, silt screens, mulches, grasses, or other erosion control devices or methods as required.

1.4 SUBMITTALS

- A. Outline description of erosion and sediment containment program complete with implementation drawings if requested; coordinate with requirements set forth in Section 01 57 19.
- B. Material samples and product data as applicable to the particular products.
- C. Material safety data sheets on all products, as necessary.

1.5 AUTHORITY

- A. The Owner's Representative and/or Architect has the authority to limit the surface area of erodible earth exposed by earthwork operations and to direct the Contractor to provide immediate temporary or permanent erosion or pollution control measures to minimize damage to property and contamination of watercourses and water impoundments.

1.6 COORDINATION AND SCHEDULING

- A. Schedule the work so as to minimize the time that raw earth areas will be exposed to erosive conditions.
- B. Coordinate the use of temporary controls with the permanent erosion control features or finish materials shown.
- C. Incorporate permanent control features into the work at the earliest practical time.

PART 2 - MATERIALS

2.1 MATERIALS

- A. Sedimentation control system shall complete including silt fence, hardwood or metal posts, etc. as manufactured by:
 - 1. Marafi Inc/Carlisle – “Envirofence System”
 - 2. Akzo Nobel – “Enkamat System”
 - 3. Webtec, Inc. – “EconoFence”or approved equal.
- B. Haybales and/or sandbags shall be as approved by the governing authorities. Haybales shall be in good condition and shall be new.
- C. Erosion Control Mats: Knitted construction containing natural wood mulch similar and equal to that as manufactured by:
 - 1. Erosion Control Systems (1020-03).
 - 2. North American Green, Inc. (Series "SC150").
 - 3. Synthetic Industries ("Polyjute").
 - 4. Webtec, Inc. (TerraJute).
 - 5. American Excelsior (Curlex).or approved equal.
- D. Grasses: Seed mixture as specified in Section 32 92 00 or other species suitable for temporary cover which will not compete with the grasses sown later for permanent cover.

PART 3 - EXECUTION

3.1 WORK AREAS

- A. The Architect may limit the area of clearing and grubbing and earthwork operations in progress commensurate with the Contractor's demonstrated capability in protecting erodible earth surfaces with temporary or permanent erosion control measures.

3.2 GENERAL

- A. The Contractor shall provide suitable and adequate means of sedimentation and erosion control during construction. Control measures shall prevent all erosion, siltation and sedimentation of waterways, drainage systems, construction areas, adjacent areas and off-site areas. Work shall be accomplished on and/or adjacent to the following work areas:
 - 1. Earthwork stockpiles and on-site storage and staging areas.
 - 2. Cut and fill slopes and other stripped and exposed graded areas.
 - 3. Constructed and existing swales and ditches.
 - 4. Unestablished lawns and seeded embankments.
- B. Means of protection as noted on the Contract Drawings indicate the minimum provisions necessary. Additional means of protection shall be provided by the Contractor as required for continued or unforeseen erosion problems, at no

- additional expense to the Government.
- C. Periodic maintenance of all sediment control installations shall be provided to ensure intended purposes are accomplished. Sediment control measures shall be in working condition at the end of each day.
 - D. After any significant rainfall, sediment control devices shall be inspected for integrity. Any damaged device shall be corrected immediately.
 - E. The Contractor shall provide adequate means of control of runoff, as to not detrimentally impact downstream conditions during construction.
 - F. In the event that the Contractor is unable to sequence the work so that construction of the permanent drainage mitigation systems precedes the upland work, then the Contractor shall submit a plan indicating his proposed methods of otherwise controlling runoff from the site.
 - G. Erosion and sediment control measures must be in place prior to construction activity and remain in place and functional until the site is permanently stabilized.
 - H. Location of erosion and sediment control measures shall be as required by the drawings and in accordance with outline of the environmental governing authority within the jurisdiction of the work.
 - I. Any area that remains in a disturbed condition where construction is not on-going for a period of more than 20 days shall receive a specified erosion control method as approved by the Contracting Officer.

3.3 SILT FENCE

- A. Install silt fence, well-staked at maximum 5 foot intervals in locations as shown on Contract Drawings and as directed. Staking shall occur on the disturbed area side.
- B. Secure fabric to posts on upstream side and bury fabric end within a 6 inch wide by 6 inch deep cut-in trench. Wrap the fabric bottom around the inside of the trench and backfill excavated soil into the fabric pocket to anchor the fence fabric.
- C. Silt fence may be used for stabilization of areas that are not stabilized at the end of the day.
- D. Install per manufacturer's requirements.

3.4 STRAW BALES

- A. Straw bale barriers may be used for existing inlet or outlet protection and stabilization of areas that are not stabilized at the end of the day.
- B. Inlet and Outlet Protection: Place straw bales around the exterior of the inlet structure to trap and retard sediment.
- C. Stabilization: Excavate a shallow trench the width and length of the bale, 4 inches deep. Place and stake straw bales into trench. Stakes shall be driven into the ground to a minimum depth of 18 inches below the grade around the straw bale. Wedge loose straw into the cracks between bales. Backfill and compact the excavated soil to form an anchor toe on the upslope side of the bale.

3.5 MAINTENANCE

- A. Inspect all erosion control devices daily. Immediately repair, adjust, and replace devices if damaged, displaced, or rendered ineffective in any way. When the area is subjected to a rainfall of 1 inch or more within 24 hours, all erosion control facilities shall be inspected and repairs shall be made within 48 hours after the storm. Disposal of materials removed from the control facilities shall be the responsibility of the Contractor as part of site restoration and cleanup.

3.6 REMOVAL AND DISPOSAL

- A. At least 70 percent of the disturbed area of the site must be established with erosion resistant cover before interim stabilization measures and temporary erosion and sedimentation control measures may be removed.
- B. Do not remove erosion control devices and materials without prior approval of the Architect.
- C. Prior to removal of devices, remove all retained silt or other materials and dispose of as specified in Section 31 23 00.

3.7 WASTE MANAGEMENT – Coordinate with Section 01 74 19

- A. Separate and recycle materials and material packaging in accordance with Waste Management Plan and to the maximum extent economically feasible and place in designated areas for recycling.
- B. Set aside and protect materials suitable for reuse and/or remanufacturing.
- C. Separate and fold up metal banding; flatten and place along with other metal scrap for recycling in designated area.

****End of Section****

SECTION 015719 - ENVIRONMENTAL PROTECTION DURING CONSTRUCTION

1.1 GENERAL

- A. Requirements set forth herein are in addition to and shall be considered as complementary to the Conditions to the Contract and the balance of Division #1 and Technical Specifications.
- B. All Contractors, Subcontractors, Sub-subcontractors, Vendors and the like shall be required to familiarize themselves with said provisions.
- C. Definitions as apply to "Contractors" involved with the work of this Project shall be as set forth in Section 01 10 00, Article 1.01.

1.2 REQUIREMENTS INCLUDED IN THIS SECTION

- A. Scope
- B. Applicable Regulations
- C. Protection of Land Resources
- D. Protection of Water Resources
- E. Burning
- F. Dust and Mud Control - Coordinate with Section 01 50 00
- G. Maintenance of Pollution Control Facilities During Construction

1.3 SCOPE

- A. The work covered by this section consists of furnishing all labor, material and equipment and performing all work required for the prevention of environmental pollution during and as the result of construction operations under this contract except for those measures set forth in other Technical Provisions of these specifications.

For the purpose of this specification environmental pollution is defined by regulatory authorities as the presence of chemical, physical or biological elements or agents which adversely affect human health or welfare; unfavorably alter ecological balances of importance to human life; affect other species of importance to man; or degrade the utility of the environment for aesthetic and recreational purposes.

The control of environmental pollution requires consideration of air, water and land, and involves noise, solid waste-management and management of radiant energy and radioactive materials, as well as other pollutants.

- B. Compliance with the provisions of this section by all Subcontractors shall be the responsibility of the Contractor.

1.4 APPLICABLE REGULATIONS

- A. In order to provide for abatement and control of any environmental pollution arising from the construction activities of the Contractor and his subcontractors in the performance of this contract, they shall comply with all applicable Federal, State and local laws, and regulations concerning environmental pollution control and abatement as well as the specific requirements stated elsewhere in the contract specifications.

1.5 PROTECTION OF LAND RESOURCES

- A. It is intended that the land resources within the project boundaries and outside the limits of permanent work performed under this contract be preserved in their present condition or be restored to a condition after completion of construction that will appear to be natural and not detract from the appearance of the project. Insofar as possible, the Contractor shall confine his construction activities to areas defined by the plans or specifications.
- B. The following additional requirements are intended to supplement and clarify the requirements contained in the General Conditions.

The location on the project site of the Contractor's storage and other construction buildings, required temporarily in the performance of the work, shall be upon assigned portions of the job site and shall require written approval of the Architect.

The preservation of the landscape shall be an imperative consideration in the selection of all sites and in the overall construction of buildings.

Plans showing storage and office facilities shall be submitted for approval of the Architect.

- C. If the Contractor proposes or is required to construct temporary roads or embankments and excavations for plant and/or work areas, he shall submit the following for approval at least 21 days prior to scheduled start of such temporary work.
 - 1. A layout of all temporary access roads, excavations and embankments to be constructed with the work area.
 - 2. Plans and cross sections of proposed embankments and their foundations, including a description of proposed materials.

1.6 PROTECTION OF WATER RESOURCES

- A. The Contractor shall not pollute streams, lakes, reservoirs or public waters with fuels, oils, bitumens, calcium chloride, acids or harmful materials.
- B. It is the responsibility of the Contractor to investigate and comply with all applicable Federal, State, County and Municipal laws concerning pollution of surrounding public waters.
- C. All work under this contract shall be performed in such a manner that objectionable conditions will not be created in public waters through or adjacent to the project areas.
- D. Prior to any major construction the Contractor shall submit a plan for approval by the Architect showing his scheme for controlling erosion and disposing of waste.
- E. Surface drainage from cuts and fills within the construction limits, whether or not completed, and from borrow and waste disposal areas, shall, if turbidity producing materials are present, be held in suitable sedimentation ponds or shall be graded to control erosion within acceptable limits. Temporary erosion and sediment control measures such as berms, dikes, drains, or sedimentation basins, if required to meet the above standards, shall be provided until permanent drainage and erosion control facilities are completed and operative. Fills and waste areas shall be constructed by selecting placement to eliminate silts or clays on the surface that will erode and contaminate adjacent public waters.

- D. At all times of the year, special measures shall be taken to prevent chemicals, fuels, oils, grease, bituminous materials, waste washings, herbicides and insecticides, and cement and surface drainage from entering public waters.
 - E. Disposal of any materials, wastes, effluents, trash, garbage, oil, grease, chemicals, etc., in areas adjacent to public waters shall be subject to the approval of the Architect.
 - F. If any waste material is dumped in unauthorized areas the Contractor shall remove the material and restore the area to the condition of the adjacent undisturbed area.
 - G. If necessary, contaminated ground shall be excavated, disposed of as directed by the Architect, refilled with clean material and compacted all at the expense of the Contractor.
- 1.7 BURNING
- A. Burning will not be permitted.
- 1.8 DUST AND MUD CONTROL - See Section 01 50 00
- 1.9 MAINTENANCE OF POLLUTION CONTROL FACILITIES DURING CONSTRUCTION
- A. During the life of this contract the Contractor shall maintain all facilities constructed for pollution control under this contract as long as the operations creating the particular pollutant are being carried out or until the material concerned has become stabilized to the extent that pollution is no longer being created.
 - B. During the construction period the Contractor shall conduct frequent training courses for his maintenance personnel. The curriculum shall include methods of detection of pollution, familiarity with pollution standards, and installation and care of vegetation covers, plants and other facilities to prevent and correct environmental pollution.

End of Section

THIS PAGE INTENTIONALLY LEFT BLANK

SECTION 016100 - MATERIAL AND EQUIPMENT

1.1 GENERAL

- A. Requirements set forth herein are in addition to and shall be considered as complementary to the Conditions of the Contract and the balance of Division #1 and Technical Specifications.
- B. All Contractors, Subcontractors, Sub-subcontractors, Vendors and the like shall be required to familiarize themselves with said provisions.

1.2 REQUIREMENTS INCLUDED IN THIS SECTION

- A. General Standards
- B. Products
- C. Sustainability
- D. Transportation and Handling
- E. Storage and Protection

1.3 GENERAL STANDARDS APPLICABLE TO ALL SPECIFICATION SECTIONS

- A. These provisions, standards, and tolerances shall apply to all work under this Contract. Where stricter standards and tolerances are specified elsewhere in these Specifications or in references specified in these Specifications, they shall take precedence over these standards and tolerances.
- B. Build and install parts of the Work level, plumb, square, and in correct position unless specifically shown or specified otherwise.
 - 1. No part shall be out of plumb, level, square, or correct position so much as to impair the proper functioning of the part or the Work as judged by the Architect.
 - 2. No part shall be out of plumb, level, square, or correct position so much as to impair the aesthetic effect of the part or the Work as judged by the Architect.
- C. Make joints tight and neat. Provide uniform joints in exposed work. Arrange joints to achieve the best visual effect. Refer choices of questionable visual effect to the Architect.
- D. Under potentially damp conditions, provide galvanic insulation between different metals which are not adjacent on the galvanic scale.
- E. Manufacturers, subcontractors, and workmen shall be experienced and skillful in performing the work assigned to them; coordinate with Article 5 of Section 00 70 00.
- F. All paint used on all products shall conform to ANSI Z66.1, Specifications for Paints and Coatings Accessible to Children to Minimize Dry Film Toxicity.
- G. The Drawings do not attempt to show every item of existing work to be demolished and every item of repair required to existing surfaces. Perform work required to remove existing materials which are not to be saved and to restore existing surfaces to condition equivalent to new as judged by Architect. If possible, repairs shall be indistinguishable from adjacent sound surfaces. Where it is impossible to achieve repairs which are indistinguishable from adjacent sound surfaces to remain, notify Architect, and proceed according to his instructions.

1.4 PRODUCTS

- A. Products include material, equipment and systems.
- B. Comply with Specifications and referenced standards as minimum requirements.

- C. Components required to be supplied in quantity within a Specification Section shall be the same, and shall be interchangeable.
- D. In the case of an inconsistency between Drawings and the Specifications, or within either document which is not clarified by addendum, the product of greater quality or greater quantity of work shall be provided in accordance with the Designer's interpretation.
- E. Provide environmentally preferable products to the greatest extent possible. To the greatest extent possible, provide products and materials that have a lesser or reduced effect on the environment considering raw materials acquisition, production, manufacturing, packaging, distribution, reuse, operation, maintenance, and/or disposal of the product.

1.5 SUSTAINABILITY

- A. In the selection of the products and materials of this section as well as for the entire project, preference will be given to those with the following characteristics:
 - 1. Water based.
 - 2. Water-soluble.
 - 3. Can be cleaned up with water.
 - 4. Non-flammable.
 - 5. Biodegradable.
 - 6. Low or preferably no Volatile Organic Compound (VOC) content.
 - 7. Manufactured without compounds that contribute to ozone depletion in the upper atmosphere.
 - 8. Manufactured without compounds that contribute to smog in the lower atmosphere.
 - 9. Do not contain methylene-chloride.
 - 10. Do not contain chlorinated hydrocarbons.
 - 11. Contains the least possible of post-consumer or post-industrial waste.

1.6 TRANSPORTATION AND HANDLING

- A. Arrange deliveries of materials in accordance with construction schedules in order to avoid delay in, conflict with, or the impeding of the progress of the Work and conditions at the site.

Deliveries shall be made during regular work hours, unless approved otherwise by the Owner.

- B. Deliver materials in undamaged condition, in manufacturer's original containers or packaging, with identifying labels intact and legible.

1.7 STORAGE AND PROTECTION

- A. Store materials in accordance with manufacturer's instructions, with seals and labels accessible for inspection.

Contractor shall be responsible for work and equipment until fully inspected, tested and accepted. Carefully store materials and equipment which are not immediately installed after delivery to site. Close open ends of work with temporary covers or plug during construction to prevent entry of obstructing material or damaging water.

- B. Materials stored on the Site shall be neatly arranged and protected, and shall be stored in an orderly fashion in locations that shall not interfere with the progress of the Work or with the operations of the Owner.
- C. Interior Storage: Maintain temperature and humidity within the ranges required by manufacturer's instructions.
- D. If it becomes necessary to remove and restack materials to avoid impeding the progress of any part of the Work or interfering with the work to be done by any other contractor employed on the Work, or interfering with the Owner's activities, the Contractor shall remove and restack such materials at no additional cost to the Owner.
- E. Protection After Installation
 - 1. Provide adequate coverings to protect installed materials from damage resulting from natural elements, traffic, and subsequent construction.
 - 2. Remove when no longer needed.

****End of Section****

THIS PAGE INTENTIONALLY LEFT BLANK

SECTION 017123 - FIELD ENGINEERING

PART 1 - GENERAL

1.1 SUMMARY

- A. This Section specified field engineering services required for the Project, including but not limited to:
 - 1. Survey work.
 - 2. Civil, structural, or other professional engineering services specified, or required to execute Contractor's construction methods.
- B. Owner's representative will identify existing control points and property line corner stakes indicated on the Drawings, as required.

1.2 REQUIREMENTS INCLUDED IN THIS SECTION

- A. Related Requirements
- B. Qualifications of Surveyor or Engineer
- C. Survey Reference Points
- D. Project Survey Requirements
- E. Records
- F. Submittals

1.3 RELATED REQUIREMENTS

- A. Examine Contract Documents for requirements that affect work on this Section. Other Specification Sections that directly relate to work of this Section include, but are not limited to:
 - 1. General Conditions and Modifications to General Conditions.
 - 2. 01 10 00 - Description of Work
 - 3. 01 77 00 - Project Closeout

1.4 QUALIFICATIONS OF SURVEYOR OR ENGINEER

- A. Qualified engineer or registered land surveyor, acceptable to Architect and Owner.
- B. Registered professional engineer of the discipline required for the specific service on the Project, licensed in the state in which the Project is located.

1.5 SURVEY REFERENCE POINTS

- A. Existing basic horizontal and vertical control points for the Project are those designated on Drawings.
- B. Locate and protect control points prior to starting sitework, and preserve all permanent reference points during construction.
 - 1. Make no changes or relocations without prior written notice to Architect.
 - 2. Report to Architect when any reference point is lost or destroyed, or requires relocation because of necessary changes in grades or locations.
 - 3. Require surveyor to replace Project control points which may be destroyed.
 - a. Establish replacements based on original survey control.

1.6 PROJECT SURVEY REQUIREMENTS

- A. Establish a minimum of two permanent bench marks on-site, referenced to data established by survey control points.
 - 1. Record locations, with horizontal and vertical data, on Project Record Documents.

- B. Establish lines and levels, locate and lay out by instrumentation and similar appropriate means:
 - 1. Site improvements.
 - a. Stakes for grading, fill, and topsoil placement.
 - b. Utility slopes and invert elevations.
 - 2. Batter boards for structures.
 - 3. Building foundation, column locations, and floor levels.
 - 4. Controlling lines and levels required for mechanical and electrical trades.
- C. From time to time, verify layouts by same methods.

1.7 RECORDS

- A. Maintain a complete, accurate log of all control and survey work as it progresses.
- B. On completion of foundation walls and major site improvements, prepare a certified survey showing all dimensions, locations, angles, and elevations of construction in accordance with the requirements of modifications to General Conditions.

1.8 SUBMITTALS

- A. Submit name and address of surveyor and professional engineer to Architect.
- B. On request of Architect, submit documentation to verify accuracy of field engineering work.
- C. Submit certificate signed by registered engineer or surveyor certifying that elevation and locations of improvements are in conformance, or non-conformance, with Contract Documents.

****End of Section****

SECTION 017419 - CONSTRUCTION WASTE MANAGEMENT

PART 1 - GENERAL

1.1 GENERAL

- A. Requirements set forth herein are in addition to and shall be considered as complementary to the Conditions of the Contract and the balance of Division #1 and Technical Specifications.
- B. All Contractors, Subcontractors, Sub-subcontractors, Vendors and the like shall be required to familiarize themselves with said provisions.
- C. Any and all "Waste Handlers and Haulers" shall be licensed by the Authority having jurisdiction over "Solid Waste Management" and a copy of said license shall be submitted in accordance with Article 1.05 herein.

1.2 DESCRIPTION OF WORK

- A. This Section specifies requirements for a complete program for implementation of waste management controls and systems for the duration of the Work and to –
 - 1. Protect the environment, both on-site and off-site, during construction operations.
 - 2. Prevent environmental pollution and damage.
 - 3. Maximize source reduction, reuse and recycling of solid waste.

1.3 INTENT

- A. The Owner has established that this Project shall generate the least amount of waste practical and that processes that ensure the generation of as little waste as possible due to error, poor planning, breakage, mishandling, contamination, or other factors shall be employed.
- B. Of the waste that is generated, as many of the waste materials as economically feasible shall be reused, salvaged, or recycled. Waste disposal in landfills shall be minimized to the greatest extent practical. Regarding these goals, the Contractor shall develop, for Owner's Representative's and Architect's review, a Waste Management Plan for this Project. The Contractor shall be responsible for ensuring that debris will be disposed of at appropriately designated licensed solid waste disposal facilities, as defined by governing laws of the jurisdiction of the Work.

1.4 WASTE MANAGEMENT PLAN

- A. After award of Contract and prior to the commencement of the Work, schedule and conduct meeting with Owner and Architect to discuss the proposed Waste Management Plan and to develop mutual understanding relative to details of environmental protection.
- B. Waste Management Plan: The Contractor shall provide a plan containing the following:
 - 1. Analysis of the proposed jobsite waste to be generated, including types and rough quantities.
 - 2. Landfill Options: The name of the landfills where trash and building debris will be disposed of, the applicable landfill tipping fees, and the projected cost of disposing of all Project waste in the landfills.
 - 3. Landfill Certification: Contractor's statement of verification that landfills proposed for use are licensed for types of waste to be deposited and have sufficient capacity to receive waste from this project.

4. Alternatives to Landfilling: A list of each material proposed to be salvaged or recycled during the course of the Project. Include the following and any additional items proposed:
 - a. Cardboard.
 - b. Clean dimensional wood.
 - c. Beverage containers.
 - d. Land clearing debris.
 - e. Concrete.
 - f. Bricks and masonry.
 - g. Asphalt.
 - h. Gypsum boards.
 - i. Acoustical ceiling material (grid separate).
 - j. Metals from framing, banding, stud trim, ductwork, piping, rebar, roofing, other trim, steel, iron, galvanized sheet steel, stainless steel, aluminum, copper, zinc, lead, brass, and bronze.
 - k. Glass, colored glass allowed.
 - l. Plastic.
 1. Type 1: Polyethylene Terephthalate (PET, PETE).
 2. Type 2: High Density Polyethylene (HDPE).
 3. Type 3: Vinyl (Polyvinyl Chloride or PVC).
 4. Type 4: Low Density Polyethylene (LDPE).
 5. Type 5: Polypropylene (PP).
 6. Type 6: Polystyrene (PS).
 7. Type 7: Other. Use of this code indicates that the package in question is made with a resin other than the six listed above, or is made of more than one resin listed above, and used in a multi-layer combination.
 - m. Paint and paint cans.
 - n. Carpet.
 - o. Insulation.
 - p. Light Fixtures and other electrical apparatus.
 - q. Others as appropriate.
5. Meetings: A description of the regular meetings to be held to address waste management.
6. Materials Handling Procedures: A description of the means by which any waste materials identified above will be protected from contamination, and a description of the means to be employed in recycling the above materials consistent with requirements for acceptance by designated facilities.
7. Transportation: A description of the means of transportation of the recyclable materials (whether materials will be site-separated and self-hauled to designated centers, or whether mixed materials will be collected by a waste hauler and removed from the site) and destination of materials.

1.5 SUBMITTALS

- A. Construction Waste Management Plan: Submit 3 copies of plan within 21 days of date established for the Notice to Proceed.
- B. Calculations and supporting documentation to demonstrate end-of-project recycling rates meeting the requirements for Construction Waste Management Plan of Item above.
- C. For materials separated for recycling off-site, establish a method for tracking the weight of the recycled material. The method shall be included in the CWM Plan for the Architect's review and approval.

- D. Waste Reduction Progress Reports: Concurrent with the Applications for Payment, submit three copies of report. Include monthly tabulations for demolition and construction waste sent off-site for disposal or recycling.
- E. Waste haulers solid waste management license.

PART 2 - PRODUCTS - NOT USED

PART 3 - EXECUTION

3.1 RECYCLING

- A. Metal, including but not limited to aluminum stairs, structural beams and sections, and reinforcing steel shall be recycled.
- B. Wood that is not painted and does not contain preservatives (i.e. creosote, arsenic, and chromium-containing preservatives) shall be segregated and recycled.

- 3.2 WASTE MANAGEMENT PLAN IMPLEMENTATION – All sorting will be done “off site” by a recognized construction and demolition processing facility who will be responsible for provision of all documentation as to where loads were processed, and the recycling rate achieved.

**End of Section **

THIS PAGE INTENTIONALLY LEFT BLANK

SECTION 017700 - PROJECT CLOSE OUT

PART 1 - GENERAL

1.1 GENERAL

- A. Requirements set forth herein are in addition to and shall be considered as complementary to the General Conditions of the Contract and the balance of Division #1 and Technical Specifications.
- B. All Contractors, Subcontractors, Sub-subcontractors, Vendors and the like shall be required to familiarize themselves with said provisions.
- C. Definitions as apply to "Contractors" involved with the work of this Project shall be as set forth in Section 01 10 00, Article 1.01.

1.2 REQUIREMENTS INCLUDED

- A. Final Cleanup
- B. Required Close Out Documentation
- C. Orientation Instruction
- D. Project Close Out Inspections
- E. Bake Out Procedures

1.3 FINAL CLEANUP

- A. The Contractor shall leave the work ready for use and occupancy without the need of further cleaning of any kind.
- B. The Contractor shall remove all tools, appliances, project signs, material and equipment from the phased areas as soon as possible upon completion of the work.
- C. The work is to be turned over to the Owner in new condition, in proper repair and in perfect adjustment.

1.4 REQUIRED CLOSE OUT DOCUMENTATION

- A. Prior to final payment the Owner shall receive, in addition to those documents required by the General Conditions, the following:
 - 1. Project record documents as per Section 01 77 18.
 - 2. The Contractor's general guarantees.
 - 3. Specific guarantees of material, equipment and systems installed in the work.
 - 4. A copy of all test data taken in connection with the work.
 - 5. Three (3) copies of all operation and maintenance manuals which shall include:
 - a. Parts List, including illustrations, assembly drawings and diagrams required for maintenance, predicted life of parts subject to wear, and recommendations for stocking spare parts.
 - b. Copies of accepted shop drawings, charts and diagrams.
 - c. Names, addresses and telephone numbers of manufacturer's representative and service company.
 - d. Letters from each manufacturer certifying that his equipment was properly installed and is operating in accordance with manufacturer's intent.
 - 6. All keys, tools, screens, spare construction material and equipment required to be furnished to the Owner as part of the work.

7. Copies of all Certification of Specifications Compliance as per Section 01 33 00.
8. Final survey if required by Municipality AND/OR Owner.
9. Record of Material Safety Data Sheets (MSDS).
10. Certified Payroll Records.

1.5 ORIENTATION INSTRUCTION

- A. Prior to final payment appropriate maintenance personnel of the Owner shall be oriented and instructed by the Contractor in the operation of all systems and equipment as required by the Contract.

1.6 PROJECT CLOSE OUT INSPECTIONS

- A. When the Work has reached such a point of completion that the building or buildings, equipment, apparatus or phase of construction or any part thereof required by the Owner for occupancy or use can be so occupied and used for the purpose intended, the Contractor, prior to notification to the Architect, shall make a preliminary inspection of the Work to insure that all the requirements of the Contract have been met and the Work is substantially complete and is acceptable.
- B. Upon such notification, the Owner or the Architect and the Construction manager shall make a detailed inspection of the Work to insure that all the requirements of the Contract have been met and that the Work is complete and is acceptable.
- C. A copy of the report of the inspection shall be furnished to the Contractor as the inspection progresses so that the Contractor may proceed without delay with any part of the Work found to be incomplete or defective.
- D. When the items appearing on the report of inspection have been completed or corrected, the Contractor shall so advise the Construction Manager and the Architect. After receipt of this notification, the Construction Manager or the Architect shall inform the Contractor of the date and time of final inspection.
- E. A copy of the report of the final inspection containing all remaining contract exceptions, omissions and incompletions shall be furnished to the Contractor.
- F. After the receipt of notification of completion and all remaining contract exceptions, omissions and incompletions from the Contractor, the Owner and Architect and the Construction Manager will reinspect the Work to verify completion of the exception items appearing on the report of final inspection.
- G. Upon completion of reinspection, the Architect will prepare a certificate of final acceptance or will furnish to the Contractor a copy of the report of the Architect's reinspection detailing Work that is incomplete or obligations that have not been fulfilled but are required for final acceptance.
- H. The Contractor shall pay the Architect and Construction Manager for services performed in inspection beyond the original inspection and two reinspections of the same area, through a "credit" change order to the Owner in accordance with Schedule outlined in Section 01 25 00.

1.7 BAKE OUT PROCEDURES HVAC CONTRACT - Coordinate with Section 01 15 01

- A. Heat all areas of new construction to 95 degrees for a minimum of 72 hours.
- B. At the end of this period ventilate area with 100 percent outside air and exhaust air for a minimum of 24 hours to eliminate off gassing that occurs during bake out period.
- C. Change all air filters upon completion.

13 January 2022
Conformed Specifications
SED #66-23-00-01-0-346-001

Yonkers Joint Schools Construction Board
Community School 35

****End of Section****

THIS PAGE INTENTIONALLY LEFT BLANK

SECTION 017719 - PROJECT RECORD DOCUMENTS
(Coordinate with Article 6 of the General Conditions)

PART 1 - GENERAL

1.1 GENERAL

- A. Requirements set forth herein are in addition to and shall be considered as complementary to the General Conditions of the Contract and the balance of Division #1 and Technical Specifications.
- B. All Contractors, Subcontractors, Sub-subcontractors, Vendors and the like shall be required to familiarize themselves with said provisions.
- C. Definitions as apply to "Contractors" involved with the work of this Project shall be as set forth in Section 01 10 00, Article 1.01.

1.2 REQUIREMENTS INCLUDED

- A. Project Record Drawings
- B. Record Drawing Certification

1.3 PROJECT RECORD DRAWINGS

- A. The purpose of the project drawings is to record the actual location of the work in place including but not limited to underground lines, concealed piping within buildings, concealed valves and control equipment, and to record changes in the work.

In addition to the above, these drawings shall be "color-coded", by each trade, on a daily basis to indicate progress of the work. Color legend will be assigned by the Architect.

- B. In addition to the sets of contract drawings that are required by the Contractor on the site to perform the work, the Contractor shall maintain, at the site, one (1) copy of all drawings, specifications and addenda that are part of the Contract as awarded.

Each of these documents should be clearly marked "Project Record Copy", maintained in a clean and neat condition available at all times for inspection by the Owner, Construction Manager or the Architect, and shall not be used for any other purpose during the progress of the work.

The Construction Manager will be the custodian of the project record documents until the end of the Project.

- C. Project Record Requirements

- 1. The Contractor shall mark-up the "Project Record Copy" to show:
 - a. Approved changes in the work.
 - b. Location of underground work and concealed work.
 - c. Details not shown in the original Contract Documents.
 - d. Any relocation of work including piping, conduits, ducts and the like.
 - e. All changes in dimensions.
 - f. All access doors and "tack" locations access points in accessible

- ceilings.
 - g. Location of all plumbing, heating, ventilating, air conditioning or electrical assemblies, whether existing to remain or newly installed.
 - h. Revisions to any electrical circuitry.
 - 2. Such information shall include, but shall not be limited to:
 - a. Footing depth in relation to finished grade elevations.
 - b. Any change in floor elevations.
 - c. Any structural changes.
 - d. Any substitutions.
 - e. Elevations and locations of all underground utilities, services, or structures referenced to permanent above ground structures or monuments.
 - f. Designation of all utilities as to the size and use of such utilities.
 - g. All invert elevations of manholes.
 - h. The location of all utilities, services and appurtenances concealed in building structures that have been installed differently from that required by the Contract.
 - i. Any approved change order.
- and other such data as required by the Architect and/or Owner so as to establish a complete record of "As-Constructed" conditions.
- D. The Contractor shall keep the project record documents up-to-date from day to day as the work progresses. Appropriate documents are to be updated promptly and accurately; no work is to be permanently concealed until all required information has been recorded.
 - E. The project record drawings are to be submitted by the Contractor to the Architect through the Construction Manager when all the work is completed and is approved by the Owner and the Architect before the Contractor may request final payment.

If the project record drawings as submitted are found to be unacceptable due to incompleteness or inaccurate information, the drawings shall be returned to the offending Contractor for corrective action and resubmitted for approval prior to the release of final payment.

FINAL PAYMENT IS CONTINGENT UPON PREPARATION OF FINAL PROJECT RECORD DRAWINGS ON A SET OF "PRINTS" and CAD DISKETTES IN "DXF" or "DWG" FORMAT AS APPROVED BY THE OWNER (A SET OF BASE DISKETTES WILL BE FURNISHED BY THE ARCHITECT) AND SUBMITTAL OF SAME TO THE OWNER, THROUGH THE ARCHITECT.

- F. In addition to the drawings required as mentioned above, the Contractor shall submit a list of all approved Shop Drawings of the Work as installed.

From this list the Architect will select the drawings desired for permanent records. The Contractor shall furnish these in a bound set to the Owner as part of the closeout requirements.

1.4 RECORD DRAWING CERTIFICATION

- A. The record drawings required under the terms and conditions of this Section shall be reviewed and processed by each of the Prime Contractors as part of their overall

contractual responsibility.

- B. This certification may be issued for individual trades or as a collective document to cover the entire record drawing requirements of the project.

The format of this certification shall be as follows:

These record drawings prepared by:

for _____ have been reviewed by the undersigned and:

Appear to be an accurate representation of the work incorporated within the project and are accepted as submitted in accordance with the technical documents.

This record document review made by this office is for determination of compliance to the requirements of the contract documents.

Firm Name: _____

Review Date: _____ By: _____

****End of Section****

THIS PAGE INTENTIONALLY LEFT BLANK

SECTION 017823 - OPERATION AND MAINTENANCE REQUIREMENTS
(Coordinate with Division 26, Most Restrictive Provisions Apply)

PART 1 - GENERAL

1.1 GENERAL

- A. Requirements set forth herein are in addition to and shall be considered as complementary to the General Conditions of the Contract and the balance of Division #1 and Technical Specifications.
- B. All Contractors, Subcontractors, Sub-subcontractors, Vendors and the like shall be required to familiarize themselves with said provisions.
- C. Definitions as apply to "Contractors" involved with the work of this Project shall be as set forth in Section 01 10 00, Article 1.01.

1.2 REQUIREMENTS INCLUDED

- A. Start Up and Demonstration
- B. Parts List
- C. Operation and Maintenance Data

1.3 START UP AND DEMONSTRATION

- A. The work required herein consists of starting up and demonstrating all systems and equipment to operating personnel and includes training of said operating personnel.
- B. The respective Trade or Subcontractor shall make arrangements, via the Owners' Representative (with notification to the Architect), as to whom the instructions are to be given in the operation of the basic and auxiliary systems and the period of time in which they are to be given.
- C. As specified in individual sections, furnish the services of instructors to train designated personnel in adjustment, operation, maintenance, and safety requirements of equipment and systems. If procedures are not specified for specific items of equipment, follow that recommended by the item Manufacturer.
- D. Instructors shall be thoroughly familiar with the equipment and systems and shall be trained in operating theory as well as practical operation and maintenance work. Instruction shall be given after the equipment or system has been accepted and turned over to the Owner. The duration of instruction shall be as specified in individual sections but shall be not less than two (2) days on each portion of operating mechanical/electrical systems. Use Operating and Maintenance Data as a training guide.
- E. The Architect shall be completely satisfied that the representative of the Owner has been thoroughly and completely instructed in the proper operation of all systems and equipment before final payment is made. If the Architect determines that complete and thorough instructions have not been given by the contractor to the Owners' Representative, then the offending Contractor shall be directed by the Architect to provide whatever instructions are necessary until the intent of this paragraph of the Specification has been complied with as determined by the Architect.

1.4 PARTS LIST

- A. As required the respective Trade or Subcontractor shall furnish three (3) typed sets of instructions for the ordering and stocking of spare parts for all equipment

installed. The lists shall include parts numbered and suggested supplier. Each set shall also include an itemized list of component parts that should be kept on hand and where such parts can be purchased.

1.5 OPERATION AND MAINTENANCE DATA

- A. The Contractor shall submit to the Architect for approval three (3) typed sets, bound neatly in hard backed loose leaf binders, of all instructions for the installation, operation, care and maintenance of all equipment, fixtures and systems.
1. Provide typed or printed label identifying binder as operating and maintenance data. List title of project, contract number, and location of equipment.
 2. Furnish manufacturer's printed data or sheets neatly typewritten on 8-1/2 inch by 11 inch, 20 pound minimum white paper. Provide indexed tabs.
 3. Drawings: Bind in with text. Provide reinforcement rings. Fold larger drawings to the size of the text pages.

Information shall indicate possible problems with equipment and suggested corrective action.

B. CONTENT OF MANUAL FOR EQUIPMENT AND SYSTEMS

The instructions shall contain information deemed necessary by the Architect and include but not be limited to the following:

1. Introduction:
 - a. Explanation of Manual and its use.
 - b. Summary description of all mechanical and electrical and equipment operating systems.
 - c. Purpose of systems.
 - d. Maintenance scheduling summary analysis, sheets and software operating instructions and diskette(s).
2. System:
 - a. Detailed description of all systems.
 - b. Illustrations, schematics, block diagrams, photographs and other exhibits.
 - c. Complete wiring diagrams, tabulations and installation drawings.
 - d. Valve tag charts and control diagrams.
 - e. 1/2 size reduced copy of "Record Drawings".
3. Operations:
 - a. Complete detailed, step-by-step, sequential description of all phases of operation for portion of the systems, including startup, shutdown, adjusting and balancing, and emergency procedures. Include all posted instruction charts.
4. Maintenance:
 - a. Parts list and parts number.
 - b. Maintenance, lubrication and replacement charts and Contractor's recommendations for preventative maintenance.
 - c. Trouble shooting charts for systems and components.
 - d. Instructions of testing each type of part.
 - e. Recommended list of on-hand spare parts.
 - f. Complete calibration instructions for all parts and entire systems.

- g. Instruction for charging, filling, draining and purging.
- h. General or miscellaneous maintenance notes.
- 5. Manufacturer's Literature:
 - a. Complete listing for all parts with names, addresses and telephone numbers.
 - b. Care and operation.
 - c. All and only pertinent brochures, illustrations, drawings, cuts, bulletins, technical data, certified performance charts and other literature with the model actually furnished to be clearly and conspicuously identified.
 - d. Internal wiring diagrams and engineering data sheets for all items and/or equipment to be furnished.
 - e. Guarantee and warranty data.
- 6. Instructions for lubricating each piece of equipment installed. Instructions shall state type of lubricant, where and how frequently lubrication is required.

Frame all instructions under glass and hang in the Mechanical Room or other location as directed by Architect.

C. MANUALS FOR PRODUCTS, MATERIALS, AND FINISHES:

- 1. Submit three (3) copies of complete manual.
- 2. Content: Provide complete information for architectural products, applied materials, and finishes.
 - a. Manufacturer's data, including catalog number, size, composition, color and texture designations, and information for reordering.
 - b. Instructions for care and maintenance, including manufacturer's recommendations for cleaning agents and methods; cautions against detrimental cleaning agents and methods; and recommended schedule for cleaning and maintenance.

****End of Section****

THIS PAGE INTENTIONALLY LEFT BLANK

SECTION 033000 - CAST-IN-PLACE CONCRETE

PART 1 - GENERAL

1.1 RELATED DOCUMENTS

- A. Drawings and general provisions of the Contract, including General and Supplementary Conditions and Division 01 Specification Sections, apply to this Section.

1.2 SUMMARY

- A. Section includes cast-in-place concrete, including formwork, reinforcement, concrete materials, mixture design, placement procedures, and finishes.
- B. Related Requirements:
 - 1. Section 312000 "Earth Moving" for drainage fill under slabs-on-grade.

1.3 DEFINITIONS

- A. Cementitious Materials: Portland cement alone or in combination with one or more of the following: blended hydraulic cement, fly ash, slag cement, other pozzolans, and silica fume; materials subject to compliance with requirements.
- B. W/C Ratio: The ratio by weight of water to cementitious materials.

1.4 PREINSTALLATION MEETINGS

- A. Preinstallation Conference: Conduct conference at Project site.
 - 1. Before submitting design mixtures, review concrete design mixture and examine procedures for ensuring quality of concrete materials. Require representatives of each entity directly concerned with cast-in-place concrete to attend, including the following:
 - a. Contractor's superintendent.
 - b. Independent testing agency responsible for concrete design mixtures.
 - c. Ready-mix concrete manufacturer.
 - d. Concrete Subcontractor.
 - e. Special concrete finish Subcontractor.
 - 2. Review special inspection and testing and inspecting agency procedures for field quality control, concrete finishes and finishing, cold- and hot-weather concreting procedures, curing procedures, construction contraction and isolation joints, and joint-filler strips, vapor-retarder installation, anchor rod and anchorage device

installation tolerances, steel reinforcement installation, methods for achieving specified floor and slab flatness and levelness floor and slab flatness and levelness measurement, concrete repair procedures, and concrete protection.

1.5 ACTION SUBMITTALS

- A. Product Data: For each type of product.
- B. Design Mixtures: For each concrete mixture. Submit alternate design mixtures when characteristics of materials, Project conditions, weather, test results, or other circumstances warrant adjustments.
- C. Steel Reinforcement Shop Drawings: Placing Drawings that detail fabrication, bending, and placement. Include bar sizes, lengths, material, grade, bar schedules, stirrup spacing, bent bar diagrams, bar arrangement, splices and laps, mechanical connections, tie spacing, hoop spacing, and supports for concrete reinforcement.
- D. Construction Joint Layout: Indicate proposed construction joints required to construct the structure.
 - 1. Location of construction joints is subject to approval of the Architect.

1.6 INFORMATIONAL SUBMITTALS

- A. Material Certificates: For each of the following, signed by manufacturers:
 - 1. Cementitious materials.
 - 2. Admixtures.
 - 3. Form materials and form-release agents.
 - 4. Steel reinforcement and accessories.
 - 5. Waterstops.
 - 6. Curing compounds.
 - 7. Vapor retarders.
 - 8. Semirigid joint filler.
 - 9. Repair materials.
- B. Material Test Reports: For the following, from a qualified testing agency:
 - 1. Aggregates.
- C. Formwork Shop Drawings: Prepared by or under the supervision of a qualified professional engineer, detailing fabrication, assembly, and support of formwork.
- D. Floor surface flatness and levelness measurements indicating compliance with specified tolerances.
- E. Field quality-control reports.

- F. Minutes of preinstallation conference.

1.7 QUALITY ASSURANCE

- A. Installer Qualifications: A qualified installer who employs on Project personnel qualified as ACI-certified Flatwork Technician and Finisher and a supervisor who is an ACI-certified Concrete Flatwork Technician.
- B. Manufacturer Qualifications: A firm experienced in manufacturing ready-mixed concrete products and that complies with ASTM C 94/C 94M requirements for production facilities and equipment.
 - 1. Manufacturer certified according to NRMCA's "Certification of Ready Mixed Concrete Production Facilities."
- C. Testing Agency Qualifications: An independent agency, acceptable to authorities having jurisdiction, qualified according to ASTM C 1077 and ASTM E 329 for testing indicated.
 - 1. Personnel conducting field tests shall be qualified as ACI Concrete Field Testing Technician, Grade 1, according to ACI CP-1 or an equivalent certification program.
 - 2. Personnel performing laboratory tests shall be ACI-certified Concrete Strength Testing Technician and Concrete Laboratory Testing Technician, Grade I. Testing agency laboratory supervisor shall be an ACI-certified Concrete Laboratory Testing Technician, Grade II.

1.8 DELIVERY, STORAGE, AND HANDLING

- A. Steel Reinforcement: Deliver, store, and handle steel reinforcement to prevent bending and damage.
- B. Waterstops: Store waterstops under cover to protect from moisture, sunlight, dirt, oil, and other contaminants.

1.9 FIELD CONDITIONS

- A. Cold-Weather Placement: Comply with ACI 306.1 and as follows. Protect concrete work from physical damage or reduced strength that could be caused by frost, freezing actions, or low temperatures.
 - 1. When average high and low temperature is expected to fall below 40 deg F for three successive days, maintain delivered concrete mixture temperature within the temperature range required by ACI 301.
 - 2. Do not use frozen materials or materials containing ice or snow. Do not place concrete on frozen subgrade or on subgrade containing frozen materials.

3. Do not use calcium chloride, salt, or other materials containing antifreeze agents or chemical accelerators unless otherwise specified and approved in mixture designs.
- B. Hot-Weather Placement: Comply with ACI 301 and ACI 305.1, and as follows:
1. Maintain concrete temperature below 90 deg F at time of placement. Chilled mixing water or chopped ice may be used to control temperature, provided water equivalent of ice is calculated to total amount of mixing water. Using liquid nitrogen to cool concrete is Contractor's option.
 2. Fog-spray forms, steel reinforcement, and subgrade just before placing concrete. Keep subgrade uniformly moist without standing water, soft spots, or dry areas.

PART 2 - PRODUCTS

2.1 CONCRETE, GENERAL

- A. ACI Publications: Comply with the following unless modified by requirements in the Contract Documents:
1. ACI 301.

2.2 STEEL REINFORCEMENT

- A. Reinforcing Bars: ASTM A 615/A 615M, Grade 60, deformed.
- B. Plain-Steel Welded-Wire Reinforcement: ASTM A 1064/A 1064M, plain, fabricated from as-drawn steel wire into flat sheets.

2.3 REINFORCEMENT ACCESSORIES

- A. Bar Supports: Bolsters, chairs, spacers, and other devices for spacing, supporting, and fastening reinforcing bars and welded-wire reinforcement in place. Manufacture bar supports from steel wire, plastic, or precast concrete according to CRSI's "Manual of Standard Practice," of greater compressive strength than concrete and as follows:
1. For concrete surfaces exposed to view, where legs of wire bar supports contact forms, use CRSI Class 1 plastic-protected steel wire or CRSI Class 2 stainless-steel bar supports.

2.4 CONCRETE MATERIALS

- A. Source Limitations: Obtain each type or class of cementitious material of the same brand from the same manufacturer's plant, obtain aggregate from single source, and obtain admixtures from single source from single manufacturer.

B. Cementitious Materials:

1. Portland Cement: ASTM C 150/C 150M, Type I/II.
2. Fly Ash: ASTM C 618, Class F.
3. Slag Cement: ASTM C 989/C 989M, Grade 100 or 120.
4. Silica Fume: ASTM C 1240, amorphous silica.

C. Normal-Weight Aggregates: ASTM C 33/C 33M, Class 3S coarse aggregate or better, graded. Provide aggregates from a single source.

1. Maximum Coarse-Aggregate Size: 1 inch nominal.
2. Fine Aggregate: Free of materials with deleterious reactivity to alkali in cement.

D. Lightweight aggregate: ASTM C330/C330M, 3/4" nominal maximum aggregate size.

E. Air-Entraining Admixture: ASTM C 260/C 260M.

F. Chemical Admixtures: Certified by manufacturer to be compatible with other admixtures and that do not contribute water-soluble chloride ions exceeding those permitted in hardened concrete. Do not use calcium chloride or admixtures containing calcium chloride.

1. Water-Reducing Admixture: ASTM C 494/C 494M, Type A.
2. Retarding Admixture: ASTM C 494/C 494M, Type B.
3. Water-Reducing and Retarding Admixture: ASTM C 494/C 494M, Type D.
4. High-Range, Water-Reducing Admixture: ASTM C 494/C 494M, Type F.
5. High-Range, Water-Reducing and Retarding Admixture: ASTM C 494/C 494M, Type G.
6. Plasticizing and Retarding Admixture: ASTM C 1017/C 1017M, Type II.

G. Water: ASTM C 94/C 94M and potable.

2.5 WATERSTOPS

A. Self-Expanding Butyl Strip Waterstops: Manufactured rectangular or trapezoidal strip, butyl rubber with sodium bentonite or other hydrophilic polymers, for adhesive bonding to concrete, 3/4 by 1 inch.

1. Manufacturers: Subject to compliance with requirements, available manufacturers offering products that may be incorporated into the Work include, but are not limited to the following:
 - a. Barrier-Bac; Inteplast Group, Ltd.
 - b. Carlisle Coatings & Waterproofing Inc.
 - c. Sika Greenstreak.

2.6 VAPOR RETARDERS

- A. Sheet Vapor Retarder: ASTM E 1745, Class A. Include manufacturer's recommended adhesive or pressure-sensitive tape.
 - 1. Manufacturers: Subject to compliance with requirements, available manufacturers offering products that may be incorporated into the Work include, but are not limited to the following:
 - a. Barrier-Bac; Intoplast Group, Ltd.
 - b. Raven Industries, Inc.
 - c. Reef Industries, Inc.

2.7 CURING MATERIALS

- A. Moisture-Retaining Cover: ASTM C 171, polyethylene film or white burlap-polyethylene sheet.
- B. Water: Potable.
- C. Clear, Waterborne, Membrane-Forming Curing Compound: ASTM C 309, Type 1, Class B, dissipating.
 - 1. Manufacturers: Subject to compliance with requirements, available manufacturers offering products that may be incorporated into the Work include, but are not limited to the following:
 - a. Anti-Hydro International, Inc.
 - b. BASF Corp. - Construction Chemicals.
 - c. Euclid Chemical Company (The); an RPM company.
 - d. W.R. Meadows, Inc.

2.8 RELATED MATERIALS

- A. Semirigid Joint Filler: Two-component, semirigid, 100 percent solids, epoxy resin with a Type A shore durometer hardness of 80 according to ASTM D 2240.
- B. Reglets: Fabricate reglets of not less than 0.022-inch-thick, galvanized-steel sheet. Temporarily fill or cover face opening of reglet to prevent intrusion of concrete or debris.
- C. Dovetail Anchor Slots: Hot-dip galvanized-steel sheet, not less than 0.034 inch thick, with bent tab anchors. Temporarily fill or cover face opening of slots to prevent intrusion of concrete or debris.

2.9 REPAIR MATERIALS

- A. Repair Underlayment: Cement-based, polymer-modified, self-leveling product that can be applied in thicknesses from 1/8 inch and that can be feathered at edges to match adjacent floor elevations.
1. Cement Binder: ASTM C 150/C 150M, portland cement or hydraulic or blended hydraulic cement as defined in ASTM C 219.
 2. Primer: Product of underlayment manufacturer recommended for substrate, conditions, and application.
 3. Aggregate: Well-graded, washed gravel, 1/8 to 1/4 inch or coarse sand as recommended by underlayment manufacturer.
 4. Compressive Strength: Not less than 4100 psi at 28 days when tested according to ASTM C 109/C 109M.
- B. Repair Overlayment: Cement-based, polymer-modified, self-leveling product that can be applied in thicknesses from 1/4 inch and that can be filled in over a scarified surface to match adjacent floor elevations.
1. Cement Binder: ASTM C 150/C 150M, portland cement or hydraulic or blended hydraulic cement as defined in ASTM C 219.
 2. Primer: Product of topping manufacturer recommended for substrate, conditions, and application.
 3. Aggregate: Well-graded, washed gravel, 1/8 to 1/4 inch or coarse sand as recommended by topping manufacturer.
 4. Compressive Strength: Not less than 5000 psi at 28 days when tested according to ASTM C 109/C 109M.

2.10 CONCRETE MIXTURES, GENERAL

- A. Prepare design mixtures for each type and strength of concrete, proportioned on the basis of laboratory trial mixture or field test data, or both, according to ACI 301.
1. Use a qualified independent testing agency for preparing and reporting proposed mixture designs based on laboratory trial mixtures.
- B. Cementitious Materials: Limit percentage, by weight, of cementitious materials other than portland cement in concrete as follows:
1. Fly Ash: 25 percent.
 2. Combined Fly Ash and Pozzolan: 25 percent.
 3. Slag Cement: 50 percent.
 4. Combined Fly Ash or Pozzolan and Slag Cement: 50 percent portland cement minimum, with fly ash or pozzolan not exceeding 25 percent.
 5. Silica Fume: 10 percent.
 6. Combined Fly Ash, Pozzolans, and Silica Fume: 35 percent with fly ash or pozzolans not exceeding 25 percent and silica fume not exceeding 10 percent.

7. Combined Fly Ash or Pozzolans, Slag Cement, and Silica Fume: 50 percent with fly ash or pozzolans not exceeding 25 percent and silica fume not exceeding 10 percent.
- C. Limit water-soluble, chloride-ion content in hardened concrete to 1.00 percent by weight of cement.
- D. Admixtures: Use admixtures according to manufacturer's written instructions.
 1. Use water-reducing high-range water-reducing or plasticizing admixture in concrete, as required, for placement and workability.
 2. Use water-reducing and -retarding admixture when required by high temperatures, low humidity, or other adverse placement conditions.
 3. Use water-reducing admixture in pumped concrete, concrete for heavy-use industrial slabs and parking structure slabs, concrete required to be watertight, and concrete with a w/c ratio below 0.50.

2.11 CONCRETE MIXTURES FOR BUILDING ELEMENTS
As indicated on drawings.

2.12 FABRICATING REINFORCEMENT

- A. Fabricate steel reinforcement according to CRSI's "Manual of Standard Practice."

2.13 CONCRETE MIXING

- A. Ready-Mixed Concrete: Measure, batch, mix, and deliver concrete according to ASTM C 94/C 94M, and furnish batch ticket information.
 1. When air temperature is between 85 and 90 deg F, reduce mixing and delivery time from 1-1/2 hours to 75 minutes; when air temperature is above 90 deg F, reduce mixing and delivery time to 60 minutes.

PART 3 - EXECUTION

3.1 FORMWORK INSTALLATION

- A. Design, erect, shore, brace, and maintain formwork, according to ACI 301, to support vertical, lateral, static, and dynamic loads, and construction loads that might be applied, until structure can support such loads.
- B. Construct formwork so concrete members and structures are of size, shape, alignment, elevation, and position indicated, within tolerance limits of ACI 117.

- C. Limit concrete surface irregularities, designated by ACI 347 as abrupt or gradual, as follows:
 - 1. Class A, 1/8 inch for smooth-formed finished surfaces.
- D. Construct forms tight enough to prevent loss of concrete mortar.
- E. Construct forms for easy removal without hammering or prying against concrete surfaces. Provide crush or wrecking plates where stripping may damage cast-concrete surfaces. Provide top forms for inclined surfaces steeper than 1.5 horizontal to 1 vertical.
 - 1. Install keyways, reglets, recesses, and the like, for easy removal.
 - 2. Do not use rust-stained steel form-facing material.
- F. Set edge forms, bulkheads, and intermediate screed strips for slabs to achieve required elevations and slopes in finished concrete surfaces. Provide and secure units to support screed strips; use strike-off templates or compacting-type screeds.
- G. Provide temporary openings for cleanouts and inspection ports where interior area of formwork is inaccessible. Close openings with panels tightly fitted to forms and securely braced to prevent loss of concrete mortar. Locate temporary openings in forms at inconspicuous locations.
- H. Chamfer exterior corners and edges of permanently exposed concrete.
- I. Form openings, chases, offsets, sinkages, keyways, reglets, blocking, screeds, and bulkheads required in the Work. Determine sizes and locations from trades providing such items.
- J. Clean forms and adjacent surfaces to receive concrete. Remove chips, wood, sawdust, dirt, and other debris just before placing concrete.
- K. Retighten forms and bracing before placing concrete, as required, to prevent mortar leaks and maintain proper alignment.
- L. Coat contact surfaces of forms with form-release agent, according to manufacturer's written instructions, before placing reinforcement.

3.2 EMBEDDED ITEM INSTALLATION

- A. Place and secure anchorage devices and other embedded items required for adjoining work that is attached to or supported by cast-in-place concrete. Use setting drawings, templates, diagrams, instructions, and directions furnished with items to be embedded.
 - 1. Install anchor rods, accurately located, to elevations required and complying with tolerances in Section 7.5 of AISC 303.
 - 2. Install reglets to receive waterproofing and to receive through-wall flashings in outer face of concrete frame at exterior walls, where flashing is shown at lintels, shelf angles, and other conditions.

3. Install dovetail anchor slots in concrete structures as indicated.

3.3 REMOVING AND REUSING FORMS

- A. General: Formwork for sides of beams, walls, columns, and similar parts of the Work that does not support weight of concrete may be removed after cumulatively curing at not less than 50 deg F for 24 hours after placing concrete. Concrete has to be hard enough to not be damaged by form-removal operations, and curing and protection operations need to be maintained.
 1. Leave formwork for beam soffits, joists, slabs, and other structural elements that support weight of concrete in place until concrete has achieved at least 70 percent of its 28-day design compressive strength.
 2. Remove forms only if shores have been arranged to permit removal of forms without loosening or disturbing shores.
- B. Clean and repair surfaces of forms to be reused in the Work. Split, frayed, delaminated, or otherwise damaged form-facing material are not acceptable for exposed surfaces. Apply new form-release agent.
- C. When forms are reused, clean surfaces, remove fins and laitance, and tighten to close joints. Align and secure joints to avoid offsets. Do not use patched forms for exposed concrete surfaces unless approved by Architect.

3.4 VAPOR-RETARDER INSTALLATION

- A. Sheet Vapor Retarders: Place, protect, and repair sheet vapor retarder according to ASTM E 1643 and manufacturer's written instructions.
 1. Lap joints 6 inches and seal with manufacturer's recommended tape.

3.5 STEEL REINFORCEMENT INSTALLATION

- A. General: Comply with CRSI's "Manual of Standard Practice" for fabricating, placing, and supporting reinforcement.
 1. Do not cut or puncture vapor retarder. Repair damage and reseal vapor retarder before placing concrete.
- B. Clean reinforcement of loose rust and mill scale, earth, ice, and other foreign materials that reduce bond to concrete.
- C. Accurately position, support, and secure reinforcement against displacement. Locate and support reinforcement with bar supports to maintain minimum concrete cover. Do not tack weld crossing reinforcing bars.
 1. Weld reinforcing bars according to AWS D1.4/D 1.4M, where indicated.

- D. Set wire ties with ends directed into concrete, not toward exposed concrete surfaces.
- E. Install welded-wire reinforcement in longest practicable lengths on bar supports spaced to minimize sagging. Lap edges and ends of adjoining sheets at least one mesh spacing. Offset laps of adjoining sheet widths to prevent continuous laps in either direction. Lace overlaps with wire.

3.6 JOINTS

- A. General: Construct joints true to line with faces perpendicular to surface plane of concrete.
- B. Construction Joints: Install so strength and appearance of concrete are not impaired, at locations indicated or as approved by Architect.
 - 1. Place joints perpendicular to main reinforcement. Continue reinforcement across construction joints unless otherwise indicated. Do not continue reinforcement through sides of strip placements of floors and slabs.
 - 2. Form keyed joints as indicated. Embed keys at least 1-1/2 inches into concrete.
 - 3. Locate joints for beams, slabs, joists, and girders in the middle third of spans. Offset joints in girders a minimum distance of twice the beam width from a beam-girder intersection.
 - 4. Locate horizontal joints in walls and columns at underside of floors, slabs, beams, and girders and at the top of footings or floor slabs.
 - 5. Space vertical joints in walls as indicated. Locate joints beside piers integral with walls, near corners, and in concealed locations where possible.
- C. Contraction Joints in Slabs-on-Grade: Form weakened-plane contraction joints, sectioning concrete into areas as indicated. Construct contraction joints for a depth equal to at least Insert depth of concrete thickness as follows:
 - 1. Sawed Joints: Form contraction joints with power saws equipped with shatterproof abrasive or diamond-rimmed blades. Cut 1/8-inch-wide joints into concrete when cutting action does not tear, abrade, or otherwise damage surface and before concrete develops random contraction cracks.
- D. Isolation Joints in Slabs-on-Grade: After removing formwork, install joint-filler strips at slab junctions with vertical surfaces, such as column pedestals, foundation walls, grade beams, and other locations, as indicated.
 - 1. Extend joint-filler strips full width and depth of joint, terminating flush with finished concrete surface unless otherwise indicated.
 - 2. Install joint-filler strips in lengths as long as practicable. Where more than one length is required, lace or clip sections together.

3.7 WATERSTOP INSTALLATION

- A. Self-Expanding Strip Waterstops: Install in construction joints and at other locations indicated, according to manufacturer's written instructions, adhesive bonding,

mechanically fastening, and firmly pressing into place. Install in longest lengths practicable.

3.8 CONCRETE PLACEMENT

- A. Before placing concrete, verify that installation of formwork, reinforcement, and embedded items is complete and that required inspections are completed.
- B. Do not add water to concrete during delivery, at Project site, or during placement unless approved by Architect.
- C. Before test sampling and placing concrete, water may be added at Project site, subject to limitations of ACI 301.
 - 1. Do not add water to concrete after adding high-range water-reducing admixtures to mixture.
- D. Deposit concrete continuously in one layer or in horizontal layers of such thickness that no new concrete is placed on concrete that has hardened enough to cause seams or planes of weakness. If a section cannot be placed continuously, provide construction joints as indicated. Deposit concrete to avoid segregation.
 - 1. Deposit concrete in horizontal layers of depth not to exceed formwork design pressures and in a manner to avoid inclined construction joints.
 - 2. Consolidate placed concrete with mechanical vibrating equipment according to ACI 301.
 - 3. Do not use vibrators to transport concrete inside forms. Insert and withdraw vibrators vertically at uniformly spaced locations to rapidly penetrate placed layer and at least 6 inches into preceding layer. Do not insert vibrators into lower layers of concrete that have begun to lose plasticity. At each insertion, limit duration of vibration to time necessary to consolidate concrete and complete embedment of reinforcement and other embedded items without causing mixture constituents to segregate.
- E. Deposit and consolidate concrete for floors and slabs in a continuous operation, within limits of construction joints, until placement of a panel or section is complete.
 - 1. Consolidate concrete during placement operations, so concrete is thoroughly worked around reinforcement and other embedded items and into corners.
 - 2. Maintain reinforcement in position on chairs during concrete placement.
 - 3. Screed slab surfaces with a straightedge and strike off to correct elevations.
 - 4. Slope surfaces uniformly to drains where required.
 - 5. Begin initial floating using bull floats or darbies to form a uniform and open-textured surface plane, before excess bleedwater appears on the surface. Do not further disturb slab surfaces before starting finishing operations.

3.9 FINISHING FORMED SURFACES

- A. Rough-Formed Finish: As-cast concrete texture imparted by form-facing material with tie holes and defects repaired and patched. Remove fins and other projections that exceed specified limits on formed-surface irregularities.
 - 1. Apply to concrete surfaces not exposed to view.
- B. Smooth-Formed Finish: As-cast concrete texture imparted by form-facing material, arranged in an orderly and symmetrical manner with a minimum of seams. Repair and patch tie holes and defects. Remove fins and other projections that exceed specified limits on formed-surface irregularities.
 - 1. Apply to concrete surfaces exposed to view, to receive a rubbed finish, or to be covered with a coating or covering material applied directly to concrete.
- C. Rubbed Finish: Apply the following to smooth-formed-finished as-cast concrete where exposed to view:
 - 1. Smooth-Rubbed Finish: Not later than one day after form removal, moisten concrete surfaces and rub with carborundum brick or another abrasive until producing a uniform color and texture. Do not apply cement grout other than that created by the rubbing process.
- D. Related Unformed Surfaces: At tops of walls, horizontal offsets, and similar unformed surfaces adjacent to formed surfaces, strike off smooth and finish with a texture matching adjacent formed surfaces. Continue final surface treatment of formed surfaces uniformly across adjacent unformed surfaces unless otherwise indicated.

3.10 FINISHING FLOORS AND SLABS

- A. General: Comply with ACI 302.1R recommendations for screeding, restraightening, and finishing operations for concrete surfaces. Do not wet concrete surfaces.
- B. Float Finish: Consolidate surface with power-driven floats or by hand floating if area is small or inaccessible to power-driven floats. Restraighten, cut down high spots, and fill low spots. Repeat float passes and restraightening until surface is left with a uniform, smooth, granular texture.
 - 1. Apply float finish to surfaces to receive trowel finish.
- C. Trowel Finish: After applying float finish, apply first troweling and consolidate concrete by hand or power-driven trowel. Continue troweling passes and restraighten until surface is free of trowel marks and uniform in texture and appearance. Grind smooth any surface defects that would telegraph through applied coatings or floor coverings.
 - 1. Apply a trowel finish to surfaces exposed to view or to be covered with resilient flooring, carpet, ceramic or quarry tile set over a cleavage membrane, paint, or another thin-film-finish coating system.

2. Finish surfaces to the following tolerances, according to ASTM E 1155, for a randomly trafficked floor surface:

a. Specified overall values of flatness, F(F) 25; and of levelness, F(L) 20; with minimum local values of flatness, F(F) 17; and of levelness, F(L) 15.

D. Broom Finish: Apply a broom finish to exterior concrete platforms, steps, ramps, and elsewhere as indicated.

1. Immediately after float finishing, slightly roughen trafficked surface by brooming with fiber-bristle broom perpendicular to main traffic route. Coordinate required final finish with Architect before application.

3.11 MISCELLANEOUS CONCRETE ITEM INSTALLATION

A. Filling In: Fill in holes and openings left in concrete structures after work of other trades is in place unless otherwise indicated. Mix, place, and cure concrete, as specified, to blend with in-place construction. Provide other miscellaneous concrete filling indicated or required to complete the Work.

B. Curbs: Provide monolithic finish to interior curbs by stripping forms while concrete is still green and by steel-troweling surfaces to a hard, dense finish with corners, intersections, and terminations slightly rounded.

C. Equipment Bases and Foundations:

1. Coordinate sizes and locations of concrete bases with actual equipment provided.
2. Construct concrete bases 4 inches high unless otherwise indicated, and extend base not less than 6 inches in each direction beyond the maximum dimensions of supported equipment unless otherwise indicated or unless required for seismic anchor support.
3. Minimum Compressive Strength: 4000 psi at 28 days.

D. Steel Pan Stairs: Provide concrete fill for steel pan stair treads, landings, and associated items. Cast-in inserts and accessories as shown on Drawings. Screed, tamp, and trowel finish concrete surfaces.

3.12 CONCRETE PROTECTING AND CURING

A. General: Protect freshly placed concrete from premature drying and excessive cold or hot temperatures. Comply with ACI 306.1 for cold-weather protection and ACI 305.1 for hot-weather protection during curing.

B. Evaporation Retarder: Apply evaporation retarder to unformed concrete surfaces if hot, dry, or windy conditions cause moisture loss approaching 0.2 lb/sq. ft. x h before and during finishing operations. Apply according to manufacturer's written instructions after placing, screeding, and bull floating or darbying concrete, but before float finishing.

- C. Formed Surfaces: Cure formed concrete surfaces, including underside of beams, supported slabs, and other similar surfaces. If forms remain during curing period, moist cure after loosening forms. If removing forms before end of curing period, continue curing for remainder of curing period.
- D. Unformed Surfaces: Begin curing immediately after finishing concrete. Cure unformed surfaces, including floors and slabs, concrete floor toppings, and other surfaces.
- E. Cure concrete according to ACI 308.1, by one or a combination of the following methods:
 - 1. Moisture Curing: Keep surfaces continuously moist for not less than seven days with the following materials:
 - a. Water.
 - b. Continuous water-fog spray.
 - c. Absorptive cover, water saturated, and kept continuously wet. Cover concrete surfaces and edges with 12-inch lap over adjacent absorptive covers.
 - 2. Moisture-Retaining-Cover Curing: Cover concrete surfaces with moisture-retaining cover for curing concrete, placed in widest practicable width, with sides and ends lapped at least 12 inches, and sealed by waterproof tape or adhesive. Cure for not less than seven days. Immediately repair any holes or tears during curing period, using cover material and waterproof tape.
 - a. Moisture cure or use moisture-retaining covers to cure concrete surfaces to receive floor coverings.
 - b. Moisture cure or use moisture-retaining covers to cure concrete surfaces to receive penetrating liquid floor treatments.
 - c. Cure concrete surfaces to receive floor coverings with either a moisture-retaining cover or a curing compound that the manufacturer certifies does not interfere with bonding of floor covering used on Project.
 - 3. Curing Compound: Apply uniformly in continuous operation by power spray or roller according to manufacturer's written instructions. Recoat areas subjected to heavy rainfall within three hours after initial application. Maintain continuity of coating and repair damage during curing period.
 - a. Removal: After curing period has elapsed, remove curing compound without damaging concrete surfaces by method recommended by curing compound manufacturer unless manufacturer certifies curing compound does not interfere with bonding of floor covering used on Project.

3.13 JOINT FILLING

- A. Prepare, clean, and install joint filler according to manufacturer's written instructions.
 - 1. Defer joint filling until concrete has aged at least one month. Do not fill joints until construction traffic has permanently ceased.

- B. Remove dirt, debris, saw cuttings, curing compounds, and sealers from joints; leave contact faces of joints clean and dry.
- C. Install semirigid joint filler full depth in saw-cut joints and at least 2 inches deep in formed joints. Overfill joint and trim joint filler flush with top of joint after hardening.

3.14 CONCRETE SURFACE REPAIRS

- A. Defective Concrete: Repair and patch defective areas when approved by Architect. Remove and replace concrete that cannot be repaired and patched to Architect's approval.
- B. Patching Mortar: Mix dry-pack patching mortar, consisting of 1 part portland cement to 2-1/2 parts fine aggregate passing a No. 16 sieve, using only enough water for handling and placing.
- C. Repairing Formed Surfaces: Surface defects include color and texture irregularities, cracks, spalls, air bubbles, honeycombs, rock pockets, fins and other projections on the surface, and stains and other discolorations that cannot be removed by cleaning.
 - 1. Immediately after form removal, cut out honeycombs, rock pockets, and voids more than 1/2 inch in any dimension to solid concrete. Limit cut depth to 3/4 inch. Make edges of cuts perpendicular to concrete surface. Clean, dampen with water, and brush-coat holes and voids with bonding agent. Fill and compact with patching mortar before bonding agent has dried. Fill form-tie voids with patching mortar or cone plugs secured in place with bonding agent.
 - 2. Repair defects on surfaces exposed to view by blending white portland cement and standard portland cement so that, when dry, patching mortar matches surrounding color. Patch a test area at inconspicuous locations to verify mixture and color match before proceeding with patching. Compact mortar in place and strike off slightly higher than surrounding surface.
 - 3. Repair defects on concealed formed surfaces that affect concrete's durability and structural performance as determined by Architect.
- D. Repairing Unformed Surfaces: Test unformed surfaces, such as floors and slabs, for finish and verify surface tolerances specified for each surface. Correct low and high areas. Test surfaces sloped to drain for trueness of slope and smoothness; use a sloped template.
 - 1. Repair finished surfaces containing defects. Surface defects include spalls, popouts, honeycombs, rock pockets, crazing and cracks in excess of 0.01 inch wide or that penetrate to reinforcement or completely through unreinforced sections regardless of width, and other objectionable conditions.
 - 2. After concrete has cured at least 14 days, correct high areas by grinding.
 - 3. Correct localized low areas during or immediately after completing surface finishing operations by cutting out low areas and replacing with patching mortar. Finish repaired areas to blend into adjacent concrete.
 - 4. Correct other low areas scheduled to receive floor coverings with a repair underlayment. Prepare, mix, and apply repair underlayment and primer according

- to manufacturer's written instructions to produce a smooth, uniform, plane, and level surface. Feather edges to match adjacent floor elevations.
5. Correct other low areas scheduled to remain exposed with a repair topping. Cut out low areas to ensure a minimum repair topping depth of 1/4 inch to match adjacent floor elevations. Prepare, mix, and apply repair topping and primer according to manufacturer's written instructions to produce a smooth, uniform, plane, and level surface.
 6. Repair defective areas, except random cracks and single holes 1 inch or less in diameter, by cutting out and replacing with fresh concrete. Remove defective areas with clean, square cuts and expose steel reinforcement with at least a 3/4-inch clearance all around. Dampen concrete surfaces in contact with patching concrete and apply bonding agent. Mix patching concrete of same materials and mixture as original concrete, except without coarse aggregate. Place, compact, and finish to blend with adjacent finished concrete. Cure in same manner as adjacent concrete.
 7. Repair random cracks and single holes 1 inch or less in diameter with patching mortar. Groove top of cracks and cut out holes to sound concrete and clean off dust, dirt, and loose particles. Dampen cleaned concrete surfaces and apply bonding agent. Place patching mortar before bonding agent has dried. Compact patching mortar and finish to match adjacent concrete. Keep patched area continuously moist for at least 72 hours.
- E. Perform structural repairs of concrete, subject to Architect's approval, using epoxy adhesive and patching mortar.
- F. Repair materials and installation not specified above may be used, subject to Architect's approval.

3.15 FIELD QUALITY CONTROL

- A. Special Inspections: Owner will engage a special inspector and qualified testing and inspecting agency to perform field tests and inspections and prepare test reports.
- B. Testing Agency: Engage a qualified testing and inspecting agency to perform tests and inspections and to submit reports.
- C. Inspections:
1. Steel reinforcement placement.
 2. Steel reinforcement welding.
 3. Headed bolts and studs.
 4. Verification of use of required design mixture.
 5. Concrete placement, including conveying and depositing.
 6. Curing procedures and maintenance of curing temperature.
 7. Verification of concrete strength before removal of shores and forms from beams and slabs.
- D. Concrete Tests: Testing of composite samples of fresh concrete obtained according to ASTM C 172/C 172M shall be performed according to the following requirements:

1. Testing Frequency: Obtain one composite sample for each day's pour of each concrete mixture exceeding 5 cu. yd., but less than 25 cu. yd., plus one set for each additional 50 cu. yd. or fraction thereof.
2. Slump: ASTM C 143/C 143M; one test at point of placement for each composite sample, but not less than one test for each day's pour of each concrete mixture. Perform additional tests when concrete consistency appears to change.
3. Air Content: ASTM C 231/C 231M, pressure method, for normal-weight concrete; ASTM C173/C173M volumetric method, for structural lightweight concrete. one test for each composite sample, but not less than one test for each day's pour of each concrete mixture.
4. Concrete Temperature: ASTM C 1064/C 1064M; one test hourly when air temperature is 40 deg F and below or 80 deg F and above, and one test for each composite sample.
5. Unit Weight: ASTM C567/C567M fresh unit weight of structural lightweight concrete.
 - a. One test for each composite sample, but not less than one test for each day's pour of each concrete mixture.
6. Compression Test Specimens: ASTM C 31/C 31M.
 - a. Cast and laboratory cure two sets of two standard cylinder specimens for each composite sample.
 - b. Cast and field cure two sets of two standard cylinder specimens for each composite sample.
7. Compressive-Strength Tests: ASTM C 39/C 39M; test one set of two laboratory-cured specimens at 7 days and one set of two specimens at 28 days.
 - a. Test one set of two field-cured specimens at 7 days and one set of two specimens at 28 days.
 - b. A compressive-strength test shall be the average compressive strength from a set of two specimens obtained from same composite sample and tested at age indicated.
8. When strength of field-cured cylinders is less than 85 percent of companion laboratory-cured cylinders, Contractor shall evaluate operations and provide corrective procedures for protecting and curing in-place concrete.
9. Strength of each concrete mixture will be satisfactory if every average of any three consecutive compressive-strength tests equals or exceeds specified compressive strength and no compressive-strength test value falls below specified compressive strength by more than 500 psi.
10. Test results shall be reported in writing to Architect, concrete manufacturer, and Contractor within 48 hours of testing. Reports of compressive-strength tests shall contain Project identification name and number, date of concrete placement, name of concrete testing and inspecting agency, location of concrete batch in Work, design compressive strength at 28 days, concrete mixture proportions and

- materials, compressive breaking strength, and type of break for both 7- and 28-day tests.
11. Nondestructive Testing: Impact hammer, sonoscope, or other nondestructive device may be permitted by Architect but will not be used as sole basis for approval or rejection of concrete.
 12. Additional Tests: Testing and inspecting agency shall make additional tests of concrete when test results indicate that slump, air entrainment, compressive strengths, or other requirements have not been met, as directed by Architect. Testing and inspecting agency may conduct tests to determine adequacy of concrete by cored cylinders complying with ASTM C 42/C 42M or by other methods as directed by Architect.
 13. Additional testing and inspecting, at Contractor's expense, will be performed to determine compliance of replaced or additional work with specified requirements.
 14. Correct deficiencies in the Work that test reports and inspections indicate do not comply with the Contract Documents.
- E. Measure floor and slab flatness and levelness according to ASTM E 1155 within 48 hours of finishing.

3.16 PAVEMENT TOLERANCES

- A. Comply with tolerances of ACI 117 and as follows:
1. Elevation: 1/4 inch (6 mm).
 2. Thickness: Plus 3/8 inch (10 mm), minus 1/4 inch (6 mm).
 3. Surface: Gap below 10-foot- (3-m-) long, unlevelled straightedge not to exceed 1/4 inch (6 mm).
 4. Lateral Alignment and Spacing of Tie Bars and Dowels: 1 inch (25 mm).
 5. Vertical Alignment of Tie Bars and Dowels: 1/4 inch (6 mm).
 6. Alignment of Tie-Bar End Relative to Line Perpendicular to Pavement Edge: 1/2 inch (13 mm).
 7. Alignment of Dowel-Bar End Relative to Line Perpendicular to Pavement Edge: Length of dowel 1/4 inch per 12 inches (6 mm per 300 mm).
 8. Joint Spacing: 3 inches (75 mm).
 9. Contraction Joint Depth: Plus 1/4 inch (6 mm), no minus.
 10. Joint Width: Plus 1/8 inch (3 mm), no minus.

END OF SECTION 033000

SECTION 042000 – UNIT MASONRY

PART 1 - GENERAL

1.1 SUMMARY

A. This Section includes unit masonry assemblies consisting of the following:

1. Concrete masonry units. (CMU)
2. Acoustical CMU
3. Face brick.
4. Mortar and grout.
5. Reinforcing steel.
6. Masonry joint reinforcement.
7. Ties and anchors.
8. Miscellaneous masonry accessories.
9. Prefabricated masonry lintels.
10. Embedded flashing.
11. Cavity-wall insulation.

B. Products furnished, but not installed, under this Section include the following:

1. Anchor sections of adjustable masonry anchors for connecting to cast-in-place concrete, installed under Division 03 Section "Cast-in-Place Concrete."
2. Mortar and grout for cast stone trim and panels installed under Division 04 Section "Cast Stone".
3. Mortar, anchors, flashing, ties and other accessories for stone masonry veneer installed under Division 04 "Stone Masonry Veneer."
4. Anchor sections of adjustable masonry anchors for connecting to structural frame, installed under Division 05 Section "Structural Steel Framing."

C. Products installed, but not furnished, under this Section include the following:

1. Steel lintels and shelf angles for unit masonry, furnished under Division 05 Section "Metal Fabrications."
2. Manufactured reglets in masonry joints for metal flashing, furnished under Division 07 Section "Sheet Metal Flashing and Trim."
3. Hollow-metal frames in unit masonry openings, furnished under Division 08 Section "Hollow Metal Doors and Frames."

1.2 DEFINITIONS

A. Reinforced Masonry: Masonry containing reinforcing steel in grouted cells.

1.3 PERFORMANCE REQUIREMENTS

- A. Provide unit masonry that develops net-area compressive strengths (f'_m) at 28 days as indicated in unit masonry performance requirements on the Structural Drawings.

1.4 ACTION SUBMITTALS

- A. Product Data: For each different masonry unit, mortar material, accessory, and other manufactured product specified.
- B. Shop Drawings: Show fabrication and installation details for the following:
 - 1. Reinforcing Steel: Detail bending and placement of unit masonry reinforcing bars. Comply with ACI 315, "Details and Detailing of Concrete Reinforcement." Show elevations of reinforced walls.
- C. Samples for Initial Selection: For the following:
 - 1. Colored mortar samples in small-scale form showing the full range of colors and textures available for each different exposed mortar color required.
- D. Samples for Verification: For the following:
 - 1. Full-size units for each different exposed masonry unit required, showing the full range of exposed colors, textures, and dimensions to be expected in the completed construction.
 - 2. Colored mortar samples, for each mortar color required, showing the full range expected in the finished construction. Make samples using the same sand and mortar ingredients to be used on Project. Label samples to indicate type and amount of colorant used
 - 3. Weep holes/vents in color to match mortar color
 - 4. Accessories embedded in the masonry.

1.5 INFORMATIONAL SUBMITTALS

- A. Qualification Data: For firms and persons specified in "Quality Assurance" Article.
- B. Material Test Reports: From a qualified testing agency indicating and interpreting test results of the following for compliance with requirements indicated:
 - 1. Each type of masonry unit required. Include size-variation data for brick, verifying that actual range of sizes falls within specified tolerances.
 - 2. Mortar complying with property requirements of ASTM C 270.
 - 3. Grout mixes complying with compressive strength requirements of ASTM C 476. Include description of type and proportions of grout ingredients.
- C. Material Certificates: Signed by manufacturers certifying that each of the following items complies with requirements:
 - 1. Each type of masonry unit required.

- a. Include size-variation data for brick, verifying that actual range of sizes falls within specified tolerances.
2. Each cement product required for mortar and grout, including name of manufacturer, brand, type, and weight slips at time of delivery.
3. Each type and size of joint reinforcement.
4. Each type and size of anchor, tie, and metal accessory.

1.6 QUALITY ASSURANCE

- A. Masonry Standard: Comply with requirements of "Specifications for Masonry Structures, ACI 530.1/ASCE 6/TSM 602" published by the American Concrete Institute, except when more stringent requirements are specified and as modified by the requirements of these Contract Documents.
 1. Revise ACI 530.1/ASCE 6/TSM 602 to exclude Article 1.5; Subparagraphs 1.1 C.1 through 4, and Subparagraphs 3.3 E.1 through 5.
- B. Installer Qualifications: Engage an experienced installer who has 10 years experience as a journeymen mason, and who has completed masonry similar in material, design, and extent to that indicated for this Project and with a record of successful in-service performance.
 1. A minimum of one skilled journeyman mason shall be present at all times during masonry erection and shall personally direct the work.
- C. Testing Agency Qualifications: An independent testing agency, acceptable to authorities having jurisdiction, qualified according to ASTM C 1093 to conduct the testing indicated, as documented according to ASTM E 548.
- D. Source Limitations for Masonry Units: Obtain exposed masonry units of a uniform texture and color, or a uniform blend within the ranges accepted for these characteristics, through one source from a single manufacturer for each product required.
- E. Source Limitations for Mortar Materials: Obtain mortar ingredients of a uniform quality, including color for exposed masonry, from one manufacturer for each cementitious component and from one source or producer for each aggregate.
- F. Fire-Resistance Ratings: Where indicated, provide materials and construction identical to those of assemblies with fire-resistance ratings determined per ASTM E 119 by a testing and inspecting agency, by equivalent concrete masonry thickness, or by another means, as acceptable to authorities having jurisdiction.
- G. Mockups: Before installing unit masonry, build mockups to verify selections made under sample submittals and to demonstrate aesthetic effects and qualities of materials and execution. Final approval of brick bonding pattern, brick color and texture and mortar color and texture will be made based on acceptance of mock-up. Build mockups to comply with the following requirements, using materials indicated for the completed Work:

1. Locate mockup in the locations as directed by Architect.
 2. Build mockups containing the following types of masonry approximately 96 inches long by 48 inches high by full thickness, including face and backup wythes and accessories. Include a sealant-filled joint at least 16 inches long in the mockup.
 - a. Typical exterior masonry-veneer wall complete with back-up, reinforcing/ties, insulation, flashing, and weep holes. Demonstrate all types of brick patterns to be used in the Work in the mock-up. Include cast stone trim units in the mock-up.
 3. Re-prepare mock-ups as required to obtain Architect's approval.
 4. Protect accepted mockups from the elements with weather-resistant membrane.
 5. Approval of mockups does not constitute approval of deviations from the Contract Documents contained in mockups unless Architect specifically approves such deviations in writing.
 6. Remove and reconstruct mockups as required to obtain Architect's approval.
 7. Approved mockups may become part of the completed Work if undisturbed at time of Substantial Completion.
- H. Preinstallation Conference: Conduct conference at Project site to comply with requirements in Division 01 Section "Project Coordination."
- I. Vertical and Lateral Fire Propagation Test Characteristics: The exterior wall assembly of the School Building is required to comply with NFPA 285 "Standard Method of Test for the Evaluation of Flammability Characteristics of Exterior Nonload-bearing Wall Assemblies Containing Combustible Components." The base wall, stud cavity insulation, wall sheathing, air barrier, continuous wall rigid insulation and exterior cladding are components that are required to be evaluated as part of this specific assembly test. All unit masonry components shall be part of an assembly that has passed NFPA 285 testing.
- J. Reference Standards: Comply with Brick Institute of America (BIA) and Masonry Institute of America (MIA) handbooks/Manuals.
- 1.7 DELIVERY, STORAGE, AND HANDLING
- A. Store masonry units on elevated platforms in a dry location. If units are not stored in an enclosed location, cover tops and sides of stacks with waterproof sheeting, securely tied. If units become wet, do not install until they are dry.
 - B. Store cementitious materials on elevated platforms, under cover, and in a dry location. Do not use cementitious materials that have become damp.
 - C. Store aggregates where grading and other required characteristics can be maintained and contamination avoided.
 - D. Deliver preblended, dry mortar mix in moisture-resistant containers designed for lifting and emptying into dispensing silo. Store preblended, dry mortar mix in delivery

containers on elevated platforms, under cover, and in a dry location or in a metal dispensing silo with weatherproof cover.

- E. Store masonry accessories, including metal items, to prevent corrosion and accumulation of dirt and oil.

1.8 PROJECT CONDITIONS

- A. Protection of Masonry: During construction, cover tops of walls, projections, and sills with waterproof sheeting at end of each day's work. Cover partially completed masonry when construction is not in progress.
- B. Do not apply uniform floor or roof loads for at least 12 hours and concentrated loads for at least three (3) days after building masonry walls or columns
- C. Stain Prevention: Prevent grout, mortar, and soil from staining the face of masonry to be left exposed or painted. Immediately remove grout, mortar, and soil that come in contact with such masonry.
 - 1. Protect base of walls from rain-splashed mud and from mortar splatter by coverings spread on ground and over wall surface.
 - 2. Protect sills, ledges, and projections from mortar droppings.
 - 3. Protect surfaces of window and door frames, as well as similar products with painted and integral finishes, from mortar droppings.
 - 4. Turn scaffold boards near the wall on edge at the end of each day to prevent rain from splashing mortar and dirt onto completed masonry.
- D. Cold-Weather Requirements: Do not use frozen materials or materials mixed or coated with ice or frost. Do not build on frozen substrates. Remove and replace unit masonry damaged by frost or by freezing conditions. Comply with cold-weather construction requirements contained in Part 1.8 C. of ACI 530.1/ASCE 6/TMS 602.
 - 1. Do not lay masonry units that are wet or frozen.
 - 2. Remove masonry damaged by freezing conditions.
- E. Cold-Weather Cleaning: Use liquid cleaning methods only when air temperature is 40 deg F (4 deg C) and above and will remain so until masonry has dried, but not less than 7 days after completing cleaning.
- F. Hot-Weather Requirements: Protect unit masonry work when temperature and humidity conditions produce excessive evaporation of water from mortar and grout. Comply with cold-weather construction requirements contained in Part 1.8 D. of ACI 530.1/ASCE 6/TMS 602. Provide artificial shade and wind breaks and use cooled materials as required.
 - 1. When ambient temperature exceeds 100 deg F (38 deg C), or 90 deg F (32 deg C) with a wind velocity greater than 8 mph (13 km/h), do not spread mortar beds more than 48 inches (1200 mm) ahead of masonry. Set masonry units within one minute of spreading mortar.

1.9 SPECIAL INSPECTIONS

- A. The Owner will engage the services of a qualified Special Inspector for this project. The Special Inspector will provide and/or coordinate inspection and testing requirements as necessary in accordance with the provisions of the Statement of Special Inspections Form contained in these Specifications.

PART 2 - PRODUCTS

2.1 CONCRETE MASONRY UNITS

- A. General: Provide shapes indicated and as follows:
 - 1. Provide special shapes for lintels, corners, jambs, sash, control joints, headers, bonding, and other special conditions.
 - 2. Provide bullnose units for outside corners that are exposed to view, unless otherwise indicated.
- B. Concrete Masonry Units (CMU): ASTM C 90 with minimum average net-area compressive strength of 1900 psi; lightweight; and as follows:
 - 1. Size: Manufactured to the following dimensions: 16 inches (407 mm) by 8 inches (203 mm) nominal; 7-5/8 inches (194 mm) by 15-5/8 inches (397 mm) actual; by thickness indicated.
 - 2. Exposed Faces: Manufacturer's standard color and texture, unless otherwise indicated.
 - 3. Provide U.L. classified units for rated walls, or units meeting the fire resistance ratings by equivalent concrete masonry thickness.
- C. Acoustical Concrete Masonry Units: Specially formed CMU with cavities and slots for sound absorption, and two additional large, straight-through cavities for vertical reinforcing, thermal insulation or accommodations for vertical conduit and/or pipes, meeting ASTM C 90, and as follows:
 - 1. Size: Manufactured to the following dimensions: 16 inches by 8 inches by 10 inches thick, nominal.
 - 2. Exposed Faces: Manufacturer's standard color and texture, with two exposed slots.
 - 3. Filler: Factory install incombustible fibrous filler material with metal septa in cavity spaces of each block
 - 4. Provide U.L. classified units for rated walls, or units meeting the fire resistance ratings by equivalent concrete masonry thickness.
 - 5. Basis of Design Product: Provide Type RSC/RF (10") Soundblox by SoundSeal Inc., or equal by Trenwyth.

2.2 BRICK

- A. General: Provide shapes indicated and as follows for each form of brick required:

1. Provide units without cores or frogs and with exposed surfaces finished for ends of sills and caps and for similar applications that would otherwise expose unfinished brick surfaces.
 2. Provide lipped brick at steel relieving angles as indicated on drawings.
- B. Provide special shapes for applications requiring brick of size, form, color, and texture on exposed surfaces that cannot be produced by sawing.
1. Provide special shapes for applications where stretcher units cannot accommodate special conditions, including those at corners, movement joints, bond beams, sashes, and lintels.
 2. Provide special shapes for applications where shapes produced by sawing would result in sawed surfaces being exposed to view.
- C. Face Brick: ASTM C 216, Grade SW, Type FBS, and as follows:
1. Unit Compressive Strength: Provide units with minimum average net-area compressive strength of 3000 psi.
 2. Initial Rate of Absorption: Less than 30 g/30 sq. in. per minute when tested per ASTM C 67.
 3. Efflorescence: Provide brick that has been tested according to ASTM C 67 and is rated "not effloresced."
 4. Type: Iron spot
 5. Sizes:
 - a. Modular: 3-5/8" w x 2-1/4" h x 7-5/8" l
 - b. Provide other shapes and sizes as indicated on the Drawings.
 6. Colors:
 - a. Lower Building: Medium Ironspot 46 by Endicott
 - b. Upper Building: Medium Ironspot 77 by Endicott
 7. Texture: Velour.

2.3 MORTAR AND GROUT MATERIALS

- A. Portland Cement: ASTM C 150, Type I or II, except Type III may be used for cold-weather construction. Provide natural color cement.
1. For concrete block work, provide natural color cement.
 2. For cast stone, stone, and brickwork, provide natural color or white cement as required to produce required mortar colors.
- B. Hydrated Lime: ASTM C 207, Type S.
- C. Portland Cement-Lime Mix: Packaged blend of portland cement complying with ASTM C 150, Type I or Type III, and hydrated lime complying with ASTM C 207.
- D. Masonry Cement: Not permitted.

- E. Aggregate for Mortar: ASTM C 144; except for joints less than 1/4 inch (6.5 mm) thick, use aggregate graded with 100 percent passing the No. 16 (1.18-mm) sieve.
 - 1. For colored mortar, provide natural sand or ground marble, granite, or other sound stone; of color necessary to produce required mortar colors.
- F. Aggregate for Grout: ASTM C 404.
- G. Mortar Pigments: Natural and synthetic iron oxides, compounded for mortar mixes. Use only pigments with a record of satisfactory performance in masonry mortars
- H. Water: Potable.

2.4 REINFORCING STEEL

- A. Uncoated Steel Reinforcing Bars: ASTM A 615/A 615M; ASTM A 616/A 616M, including Supplement 1; or ASTM A 617/A 617M, Grade 60 (Grade 400).

2.5 MASONRY JOINT REINFORCEMENT

- A. General: ASTM A 951 and as follows:
 - 1. Mill galvanized, carbon-steel wire for interior walls, unless noted below.
 - 2. Hot-dip galvanized, carbon-steel wire for exterior walls and interior walls at Basement locations.
 - 3. Wire Size for Side Rods: W1.7 or 0.148-inch (3.8-mm) diameter.
 - 4. Wire Size for Cross Rods: W1.7 or 0.148-inch (3.8-mm) diameter.
 - 5. Provide in lengths of not less than 10 feet (3 m), with prefabricated corner and tee units where indicated.
- B. For single-wythe masonry, provide ladder type with single pair of side rods and cross rods spaced not more than 16 inches (407 mm) o.c.
- C. For multi wythe masonry, provide types as follows:
 - 1. Adjustable (2-piece) type with single pair of side rods and cross ties spaced not more than 16 inches (407 mm) o.c. and with separate adjustable veneer ties engaging the cross ties. Cross ties are U-shaped with eyes. Space side rods for embedment within each face shell of backup wythe and size adjustable ties to extend at least halfway through outer wythe but with at least 5/8-inch (16-mm) cover on outside face

2.6 TIES AND ANCHORS, GENERAL

- A. General: Provide ties and anchors, specified in subsequent articles, made from materials that comply with this Article, unless otherwise indicated.
- B. Stainless Steel Wire: ASTM A580/A580M, Type 304.

- C. Stainless Steel Sheet: ASTM A240/A240M or ASTM A666, Type 304.
- D. Stainless Steel Bars: ASTM A276 or ASTM A666, Type 304.
- E. Mill Galvanized Carbon-Steel Wire: ASTM A 82; with ASTM A 641 (ASTM A 641M), Class 1 coating.
- F. Hot-Dip Galvanized Carbon-Steel Wire: ASTM A 82; with ASTM A 153, Class B-2 coating.
- G. Steel Sheet, Galvanized after Fabrication: ASTM A 366/A 366M cold-rolled, carbon-steel sheet hot-dip galvanized after fabrication to comply with ASTM A 153
- H. Steel Plates, Shapes, and Bars: ASTM A 36/A 36M.

2.7 JOINT STABILIZATION ANCHORS

- A. General: Contractor's option to select between the two types listed below.
- B. Three-piece assemblies allowing movement at expansion, contraction or isolation joint while maintaining wall alignment in direction normal to the movement. Two 3/16-inch (4.8-mm) diameter wire rods with plastic sleeves separating two 1/32-inch (0.8-mm) sheet metal sleeves for embedding completely in mortar, zinc plated; Hohmann & Barnard "Slip-Set Stabilizer" or equivalent.
- C. Galvanized 3/8-inch (9-mm) by 6 inches (150 mm) steel dowel vertically welded to a 2-inch (50-mm) by 5-inch (125-mm) steel plate with slotted holes for mounting to the underside of beams or deck, and a plastic sleeve with compressible filler to prevent dowel from bonding with mortar; Hohmann & Barnard PTA-420 with tube or equivalent.

2.8 ADJUSTABLE ANCHORS FOR CONNECTING TO STEEL FRAME

- A. General: Provide two-piece assemblies that allow vertical or horizontal adjustment but resist tension and compression forces perpendicular to plane of wall.
 - 1. Anchor Section: Crimped 1/4-inch- (6.4-mm-) diameter, stainless steel anchor section for welding to steel.
 - 2. Tie Section: Triangular-shaped wire tie, sized to extend within 1 inch (25 mm) of masonry face, made from 0.1875-inch- (4.8-mm-) stainless steel.
 - 3. Basis of Design Product: Hohmann & Barnard 359-FH Weld On Tie with VBT Vee Byna-Tie or one of the following, or equal.
 - a. Type I Weld On Anchor and 1100 Tie by Wire Bond.
 - b. 315-B Weld On Anchor and 316 Triangle Tie by Heckmann Building Products

2.9 ANCHORS FOR CONNECTING TO CONCRETE

- A. General: Provide two-piece assemblies that allow vertical or horizontal adjustment but resist tension and compression forces perpendicular to plane of wall.

1. Anchor Section: Dovetail anchor section formed from minimum 0.0966-inch- (2.5-mm-) thick, stainless steel sheet.
2. Tie Section: Triangular-shaped wire tie, sized to extend within 1 inch (25 mm) of masonry face, made from 0.1875-inch- (4.8-mm-) stainless steel wire.
3. Basis of Design Product: Hohmann & Barnard 305 Dovetail Slot with 315 Flexible Dovetail Brick Tie or one of the following, or equal:
 - a. 2102 Tie and 1304 Dovetail Slot by Wire Bond.
 - b. 103 Tie and 100 Dovetail Slot by Heckmann Building Products
4. Use for stone veneer and brick.

2.10 ADJUSTABLE MASONRY-VENEER ANCHORS

- A. General: Provide two-piece assemblies that allow vertical or horizontal adjustment but resist tension and compression forces perpendicular to plane of wall, for attachment over sheathing or insulation to wood or metal studs, and as follows:
 1. Structural Performance Characteristics: Capable of withstanding a 100-lbf (445-N) load in both tension and compression without deforming or developing play in excess of 0.05 inch (1.3 mm).
- B. Screw-Attached, Masonry-Veneer Anchors for Metal Stud Back-up Construction: Units consisting of a wire tie section and a metal anchor section complying with the following requirements:
 1. Anchor Section: Rib-stiffened, sheet metal plate with 9/32" diameter screw holes top and bottom; with projecting tabs having slotted holes for inserting vertical legs of wire tie specially formed to fit anchor section.
 2. Wire Tie Section: Rectangular- shaped wire tie sized to extend at least halfway through veneer but with at least 5/8-inch (16-mm) cover on outside face.
 3. Fabricate sheet metal anchor sections and other sheet metal parts from 14 gauge (1.9 mm) thick, stainless steel sheet.
 4. Fabricate wire tie sections from 3/16 inch- (4.8-mm-) diameter, stainless steel wire.
 5. Basis of Design Product: One of the following or equal:
 - a. RJ-711;. Wire-Bond
 - b. HB-213; Hohmann & Barnard, Inc.
 - c. #213 Anchor with #282 Tie; Heckmann Building Products
- C. Stainless-Steel Drill Screws for Steel Studs: Either made from Type 410 stainless steel or made with a carbon-steel drill point and 300 Series stainless-steel shank, complying with ASTM C 954 except manufactured with hex washer head and neoprene washer, No. 10 (4.8-mm) diameter by length required to penetrate steel stud flange by not less than three exposed threads
- D. Expansion Bolt-Attached, Masonry-Veneer Anchors for Existing Masonry or Concrete Back-up Construction (and where dovetail slots have not been installed in concrete): Units consisting of a wire tie section and a metal anchor section complying with the following requirements:

1. Anchor Section: Rib-stiffened, sheet metal plate with 7/16" diameter bolt hole in the center for use with brass expansion bolt; with projecting tabs having slotted holes for inserting vertical legs of wire tie specially formed to fit anchor section.
 2. Wire Tie Section: Rectangular- shaped wire tie sized to extend at least halfway through veneer but with at least 5/8-inch (16-mm) cover on outside face.
 3. Fabricate sheet metal anchor sections and other sheet metal parts from 14 gauge (1.9-mm-) thick, stainless steel sheet.
 4. Fabricate wire tie sections from 3/16-inch- (4.8-mm-) diameter, stainless steel wire.
 5. Basis of Design Product: HB-5213 by Hohmann & Barnard, Inc. or comparable system/product by one of the following:
 - a. Wire-Bond
 - b. Heckmann Building Products (Pos-I-Tie system)
 6. Use for stone veneer and brick.
- E. Brass Expansion Bolt for Existing Masonry or Concrete Back-up Construction: Masonry fastener for fastening anchors to concrete, block, brick and into mortar joints complying with the following requirements:
1. Internal Bolt: 1/4" diameter – 20, Type 304 stainless steel.
 2. Stainless Steel Washer: 3/4" OD, Type 18-8 stainless steel.
 3. Knurled Expansion Sleeve and Expander Cone: Brass 260 alloy.
 4. Fixture Clearance Hole: 7/16" diameter
 5. ANSI Drill Bit Size: 3/8" diameter
 6. Basis of Design Product: 523 Brass Expansion Bolt by Hohmann & Barnard, Inc. or equal system/product by one of the following:
 - a. Wire-Bond
 - b. Heckmann Building Products

2.11 RIGID ANCHORS

- A. General: Fabricate from steel bars as follows:
1. 1-1/2 inches (38 mm) wide by 1/4 inch (6.4 mm) thick by 24 inches (600 mm) long, with ends turned up 2 inches (50 mm) or with cross pins.
 2. Finish: Hot-dip galvanized to comply with ASTM A 153.

2.12 MISCELLANEOUS ANCHORS

- A. Anchor Bolts: Steel bolts complying with ASTM A 307, Grade A (ASTM F 568, Property Class 4.6); with ASTM A 563 (ASTM A 563M) hex nuts and, where indicated, flat washers; hot-dip galvanized to comply with ASTM A 153, Class C; of diameter and length indicated and in the following configurations:
1. Headed bolts.

- B. Postinstalled Anchors: Anchors as described below, with capability to sustain, without failure, load imposed within factors of safety indicated, as determined by testing per ASTM E 488, conducted by a qualified independent testing agency.
1. Type: Chemical anchors.
 2. Type: Expansion anchors.
 3. Corrosion Protection (Indoor): Carbon-steel components zinc plated to comply with ASTM B 633, Class Fe/Zn 5 (5 microns) for Class SC 1 service condition (mild).
 4. Corrosion Protection: Stainless-steel components complying with ASTM F 593 and ASTM F 594, Alloy Group 1 or 2 (ASTM F 738M and ASTM F 836M, Alloy Group 1 or 4) for bolts and nuts; ASTM A 666 or ASTM A 276, Type 304 or 316, for anchors.
 5. For Postinstalled Anchors in Concrete: Capability to sustain, without failure, a load equal to four times the loads imposed.
 6. For Postinstalled Anchors in Grouted Masonry Units: Capability to sustain, without failure, a load equal to six times the loads imposed.

2.13 EMBEDDED FLASHING MATERIALS

- A. Concealed Adhered Masonry Flashing: Provide stainless steel fabric laminated sheet flashing overlapping a full bed depth stainless steel drip as follows:
1. Basis of Design Product: Provide specified product of Hohmann & Barnard or equal products by York or Wire-Bond.
 2. Sheet-Metal Drip Flashing: Fabricate from 22 gage stainless steel with the drip edge hemmed approximately 3/16-inch and a 2 inch turn-up, as indicated on Drawings.
 3. Termination Bar: Stainless steel.
 4. Self-Adhering Stainless Steel Fabric Laminated Sheet Flashing: Manufacturer's standard composite membrane consisting of a polymeric film laminated to a .003 inch stainless steel sheet, with a pressure-sensitive, clear adhesive; non-asphaltic; Mighty-Flash – SA Self-Adhering Stainless Steel Fabric Flashing by Hohmann & Barnard or equal. Verify compatibility with air barrier system that sheet flashing contacts.
 - a. Primer: Flashing manufacturer's standard product or product recommended by flashing manufacturer for bonding flashing sheets to masonry and concrete; Primer – SA by Hohmann & Barnard or equal.
- B. Metal Flashing: Provide metal flashing complying with Section 076200 "Sheet Metal Flashing and Trim" and as follows:
1. Stainless Steel: ASTM A 240/A 240M, Type 304, 26 gauge 0.016 inch (0.40 mm) thick.
 2. Fabricate drip edge in one continuous length, 4 inches wide, with a hemmed outer edge condition held flush with face of finished masonry.
- C. Application: Unless otherwise indicated, use the following:

1. Where flashing is indicated to receive counterflashing, use metal flashing.
2. Where flashing is partly exposed and is indicated to terminate at the wall face, use concealed flexible flashing with a metal drip edge.
3. Where flashing is fully concealed, use flexible flashing.

2.14 CAVITY-WALL INSULATION

- A. Extruded-Polystyrene Board Insulation: ASTM C 578, Type X, 15-psi (104-kPa) minimum compressive strength, with maximum flame-spread and smoke-developed indexes of 25 and 450, respectively, per ASTM E 84. .
1. Products: Subject to compliance with requirements, provide one of the following:
 - a. DiversiFoam Products; CertaFoam 15.
 - b. DuPont; Dow Styrofoam Brand Cavitymate.
 - c. Owens Corning; Foamular CW15 Square Edge.
 2. Thickness: As indicated on Drawings.
 3. Fire Propagation Characteristics: Passes NFPA 285 testing as part of an approved assembly.
 4. Edges: Square edge.
- B. Tape for Sealing Joints in Insulation: Type recommended by insulation board manufacturer for application indicated.
- C. Adhesive: Type recommended by insulation board manufacturer for application indicated

2.15 MISCELLANEOUS MASONRY ACCESSORIES

- A. Compressible Filler: Premolded filler strips complying with ASTM D 1056, Grade 2A1; compressible up to 35 percent; of width and thickness indicated; formulated from neoprene.
- B. Preformed Control-Joint Gaskets: Material as indicated below, designed to fit standard sash block and to maintain lateral stability in masonry wall; size and configuration as indicated, or required.
1. Styrene-Butadiene-Rubber Compound: ASTM D 2000, Designation M2AA-805.
 2. Product: Hohmann & Barnard, Inc., RS Series or equal.
- C. Bond-Breaker Strips: Asphalt-saturated, organic roofing felt complying with ASTM D 226, Type I (No. 15 asphalt felt).
- D. Wicking Material: Absorbent rope, made from UV-resistant synthetic fiber, 1/4 to 3/8 inch (6 to 10 mm) in diameter, in length required to produce 2-inch (50-mm) exposure on exterior and 18 inches (450 mm) in cavity. Use only for weeps.
1. Application: At cast stone panels and trim, stone veneer and other locations as indicated

- E. Mesh Weep/Vent: Free-draining mesh; made from polyethylene strands, full height and width of head joint and depth 1/8 inch (3 mm) less than depth of outer wythe.
 - 1. Color: Match mortar color.
 - 2. Manufacturers: Subject to compliance with requirements, provide products by one of the following or equivalent:
 - a. WeepVent by Mortar Net Solutions.
 - b. CavClear Weep Vents.
 - c. Weep Mesh by Advanced Building Products
 - 3. Application: At brick veneer.
- F. Cavity Drainage Material: 2-inch- (50-mm-) thick, reticulated, nonabsorbent mesh, made from polyethylene strands with 90% open plastic mesh configuration, and dovetail shape to maintain drainage at weep holes without being clogged by mortar droppings.
 - 1. Basis of Design Product: Provide one of the following or equivalent:
 - a. Mortar Net by Mortar Net Solutions
 - b. Mortar Trap by Hohmann & Barnard, Inc.
 - c. ProNet by Masonpro
- G. Cavity Drainage Material: 3/4-inch- (50-mm-) thick, reticulated, nonabsorbent mesh, made from polyethylene strands with 90% open plastic mesh configuration.
 - 1. Use in cavities with masonry back up and with less than 1 1/8" clear cavity only.
 - 2. Product: Subject to compliance with requirements, provide CavClear Masonry Mat manufactured by CavClear.

2.16 MASONRY CLEANERS

- A. Job-Mixed Detergent Solution: Solution of 1/2-cup (0.14-L) dry measure tetrasodium polyphosphate and 1/2-cup (0.14-L) dry measure laundry detergent dissolved in 1 gal. (4 L) of water.
- B. Proprietary Acidic Cleaner: Manufacturer's standard-strength cleaner designed for removing mortar/grout stains, efflorescence, and other new construction stains from new masonry without discoloring or damaging masonry surfaces. Use product expressly approved for intended use by cleaner manufacturer and manufacturer of masonry units being cleaned.
 - 1. Products for Cleaning Unit Masonry: Subject to compliance with requirements, provide one of the following:
 - a. Cleaners for Red and Light-Colored Brick Not Subject to Metallic Staining with Mortar Not Subject to Bleaching: Sure Klean No. 600 Detergent; ProSoCo, Inc.
 - b. Cleaners for Red and Dark-Colored Brick Not Subject to Metallic Staining: Sure Klean No. 101 Lime Solvent; ProSoCo., Inc.

- c. Cleaners for Brick Subject to Metallic Staining: Sure Klean Vana Trol; ProSoCo, Inc.

2.17 MORTAR AND GROUT MIXES

- A. General: Do not use admixtures, including pigments, air-entraining agents, accelerators, retarders, water-repellent agents, antifreeze compounds, or other admixtures, unless otherwise indicated.
 - 1. Do not use calcium chloride in mortar or grout.
- B. Preblended, Dry Mortar Mix: Furnish dry mortar ingredients in the form of a preblended mix. Measure quantities by weight to ensure accurate proportions, and thoroughly blend ingredients before delivering to Project site.
- C. Colored Mortar for Cast Stone, Stonework and Brickwork: Produce mortar of color specified, and to match approved mock-ups by using selected ingredients. Do not alter specified proportions without Architect's approval.
 - 1. Use naturally colored aggregates to produce required mortar color to greatest extent possible, before adding pigments.
 - 2. Pigments: Where mortar pigments are used, do not exceed a pigment-to-cement ratio of 1:10 by weight.
 - 3. Color: As selected by Architect from manufacturer's standard colors.
- D. Mortar for Unit Masonry: Comply with ASTM C 270, Proportion Specification.
 - 1. Limit cementitious materials in mortar to portland cement and lime.
 - 2. For masonry below grade, in contact with earth, and where indicated, use Type M.
 - 3. For reinforced masonry, shear walls, exterior above-grade load-bearing and exterior above-grade non-load-bearing walls, interior load-bearing walls, parapet walls, and where indicated, use Type N.
 - 4. For interior non-load-bearing partitions; and for other applications where another type is not indicated, use Type N.
 - 5. For cast stone and stone veneer units, use Type N.
- E. Grout for Unit Masonry: Comply with ASTM C 476.
 - 1. Use grout of type indicated or, if not otherwise indicated, of type (fine or coarse) that will comply with Table 5 of ACI 530.1/ASCE 6/TMS 602 for dimensions of grout spaces and pour height.
 - 2. Provide grout with a slump of 8 to 11 inches (200 to 280 mm) as measured according to ASTM C 143.

PART 3 - EXECUTION

3.1 EXAMINATION

- A. Examine conditions, with Installer present, for compliance with requirements for installation tolerances and other conditions affecting performance.
 - 1. For the record, prepare written report, endorsed by Installer, listing conditions detrimental to performance.
 - 2. Verify that foundations are within tolerances specified.
 - 3. Proceed with installation only after unsatisfactory conditions have been corrected.
- B. Before installation, examine rough-in and built-in construction to verify actual locations of piping connections.

3.2 INSTALLATION, GENERAL

- A. For cold-weather construction comply with requirements contained in ACI 530.1-05
- B. Thickness: Build cavity and composite walls and other masonry construction to the full thickness shown. Build single-wythe walls to the actual widths of masonry units, using units of widths indicated.
- C. Build chases and recesses to accommodate items specified in this Section and in other Sections of the Specifications.
- D. Leave openings for equipment to be installed before completing masonry. After installing equipment, complete masonry to match the construction immediately adjacent to the opening.
- E. Cut masonry units with motor-driven saws to provide clean, sharp, un-chipped edges. Cut units as required to provide a continuous pattern and to fit adjoining construction. Where possible, use full-size units without cutting. Allow units cut with water-cooled saws to dry before placing, unless wetting of units is specified. Install cut units with cut surfaces and, where possible, cut edges concealed.
- F. Select and arrange units for exposed unit masonry to produce a uniform blend of colors and textures.
 - 1. Mix units from several pallets or cubes as they are placed.
- G. Wetting of Brick: Wet brick before laying if the initial rate of absorption exceeds 30 g/30 sq. in. (30 g/194 sq. cm) per minute when tested per ASTM C 67. Allow units to absorb water so they are damp but not wet at the time of laying

3.3 CONSTRUCTION TOLERANCES

- A. Comply with tolerances in ACI 530.1/ASCE 6/TMS 602 and the following:
- B. For conspicuous vertical lines, such as external corners, door jambs, reveals, and expansion and control joints, do not vary from plumb by more than 1/4 inch in 20 feet (6 mm in 6 m), nor 1/2 inch (12 mm) maximum.

- C. For vertical alignment of exposed head joints, do not vary from plumb by more than 1/4 inch in 10 feet (6 mm in 3 m), nor 1/2 inch (12 mm) maximum.
- D. For conspicuous horizontal lines, such as exposed lintels, sills, parapets, and reveals, the following tolerances will apply.
 - 1. Variation from Plumb: Do not exceed 1/8 inch in 10 feet (3 mm in 3 m) or 1/4 inch in 20 feet (6 mm in 6 m) or more.
 - 2. Variation from Level: Do not exceed 1/8 inch in 10 feet (3 mm in 3 m), 1/4 inch in 20 feet (6 mm in 6 m), or 3/8 inch (9 mm) maximum.
 - 3. Variation in Joint Width: Do not vary joint thickness more than 1/8 inch in 36 inches (3 mm in 900 mm) or one-fourth of nominal joint width, whichever is less.
 - 4. Variation in Plane between Adjacent Surfaces (Lipping): Do not exceed 1/16-inch (1.5-mm) difference between planes of adjacent units or adjacent surfaces indicated to be flush with units.
- E. For exposed bed joints, do not vary from thickness indicated by more than plus or minus 1/8 inch (3 mm), with a maximum thickness limited to 1/2 inch (12 mm). Do not vary from bed-joint thickness of adjacent courses by more than 1/8 inch (3 mm).
- F. For exposed head joints, do not vary from thickness indicated by more than plus or minus 1/8 inch (3 mm). Do not vary from adjacent bed-joint and head-joint thicknesses by more than 1/8 inch (3 mm).

3.4 LAYING MASONRY WALLS

- A. Lay out walls in advance for accurate spacing of surface bond patterns with uniform joint thicknesses and for accurate location of openings, movement-type joints, returns, and offsets. Avoid using less-than-half-size units, particularly at corners, jambs, and, where possible, at other locations.
- B. Bond Pattern for Exposed Masonry: Lay exposed masonry in running bond pattern unless otherwise indicated; do not use units with less than nominal 4-inch (100-mm) horizontal face dimensions at corners or jambs.
 - 1. For brickwork, lay brick in running bond pattern with soldier course above windows and where indicated, and recessed/reveal courses, as indicated on Drawings.
- C. Lay concealed masonry with all units in a wythe in running bond or bonded by lapping not less than 2 inches (50 mm). Bond and interlock each course of each wythe at corners. Do not use units with less than nominal 4-inch (100-mm) horizontal face dimensions at corners or jambs.
- D. Stopping and Resuming Work: In each course, rack back one-half-unit length for one-half running bond or one-third-unit length for one-third running bond; do not tooth. Clean exposed surfaces of set masonry, wet clay masonry units lightly if required, and remove loose masonry units and mortar before laying fresh masonry.

- E. Built-in Work: As construction progresses, build in items specified under this and other Sections of the Specifications. Fill in solidly with masonry around built-in items.
- F. Fill space between hollow-metal frames and masonry solidly with mortar, unless otherwise indicated.
- G. Where built-in items are to be embedded in cores of hollow masonry units, place a layer of metal lath in the joint below and rod mortar or grout into core.
- H. Fill cores in hollow concrete masonry units with grout 24 inches (600 mm) under bearing plates, beams, lintels, posts, and similar items, unless otherwise indicated, and at all exterior wall locations.
- I. Build non-load-bearing interior partitions full height of story to underside of solid floor or roof structure above, unless otherwise indicated.
 - 1. Install compressible filler in joint between top of partition and underside of structure above.
 - 2. At fire-rated partitions, install firestopping in joint between top of partition and underside of structure above to comply with Division 07 Section "Firestopping."

3.5 MORTAR BEDDING AND JOINTING

- A. Lay hollow masonry units as follows:
 - 1. With full mortar coverage on horizontal and vertical face shells.
 - 2. Bed webs in mortar in starting course on footings and in all courses of piers, columns, and pilasters, and where adjacent to cells or cavities to be filled with grout.
 - 3. For starting course on footings where cells are not grouted, spread out full mortar bed, including areas under cells.
- B. Lay solid brick-size masonry units with completely filled bed and head joints; butter ends with sufficient mortar to fill head joints and shove into place. Do not deeply furrow bed joints or slush head joints.
 - 1. At cavity walls, bevel beds away from cavity, to minimize mortar protrusions into cavity. As work progresses, trowel mortar fins protruding into cavity flat against the cavity face of the brick.
- C. Tool exposed joints slightly concave when thumbprint hard, using a jointer larger than the joint thickness, unless otherwise indicated.
- D. Collar Joints in Masonry: Fill the vertical, longitudinal joint between wythes solidly with grout for exterior walls noted, do not fill insulated cavity walls.

3.6 CAVITIES

- A. Keep cavities clean of mortar droppings and other materials during construction. Strike joints facing cavities flush.
 - 1. Use wood strips temporarily placed in cavity to collect mortar droppings. As work progresses, remove strips, clean off mortar droppings, and replace in cavity.
- B. Apply air barrier to face of backup to comply with Section 072726 "Fluid-Applied Membrane Air Barriers."
- C. Installing Cavity-Wall Insulation: Place small dabs of adhesive, spaced approximately 12 inches (300 mm) o.c. both ways, on inside face of insulation boards, or attach with plastic fasteners designed for this purpose. Fit courses of insulation between wall ties and other confining obstructions in cavity, with edges butted tightly both ways. Press units firmly against inside wythe of masonry or other construction as shown.
 - 1. Fill cracks and open gaps in insulation with crack sealer compatible with insulation and masonry.

3.7 MASONRY JOINT REINFORCEMENT

- A. General: Provide continuous masonry joint reinforcement as indicated. Install entire length of longitudinal side rods in mortar with a minimum cover of 5/8 inch (16 mm) on exterior side of walls, 1/2 inch (13 mm) elsewhere. Lap reinforcement a minimum of 6 inches (150 mm).
 - 1. Space reinforcement not more than 16 inches (406 mm) o.c.
 - 2. Space reinforcement not more than 8 inches (203 mm) o.c. in foundation walls and parapet walls.
 - 3. Provide reinforcement not more than 8 inches (203 mm) above and below wall openings and extending 12 inches (305 mm) beyond openings.
 - a. Reinforcement above is in addition to continuous reinforcement.
- B. Cut or interrupt joint reinforcement at control and expansion joints, unless otherwise indicated.
- C. Provide continuity at corners and wall intersections by using prefabricated "L" and "T" sections. Cut and bend reinforcing units as directed by manufacturer for continuity at returns, offsets, column fireproofing, pipe enclosures, and other special conditions.

3.8 ANCHORING MASONRY TO STRUCTURAL MEMBERS

- A. Anchor masonry to structural members where masonry abuts or faces structural members to comply with the following:
 - 1. Provide an open space not less than 1 inch (25 mm) in width between masonry and structural member, unless otherwise indicated. Keep open space free of mortar or other rigid materials.
 - 2. Anchor masonry to structural members with flexible anchors embedded in masonry joints and attached to structure.

3. Space anchors as indicated, but not more than 16 inches (406 mm) o.c. vertically and 16 inches (406 mm) o.c. horizontally, with not less than 1 anchor for each 1.77 sq. ft. (0.16 sq. m) of wall area.

3.9 ANCHORING MASONRY VENEERS

- A. Anchor masonry veneers to wall framing or solid backup with masonry-veneer anchors to comply with the following requirements:
 1. Fasten each anchor section through sheathing to metal wall framing with two metal screw fasteners of type indicated.
 2. Fasten each anchor section to CMU or concrete back-up with to expansion bolt anchors
 3. Embed tie sections in masonry joints. Provide not less than 2 inches (50 mm) of air space between back of masonry veneer and face of sheathing.
 4. Locate anchor sections to allow maximum vertical differential movement of ties up and down.
 5. Space anchors as indicated, but not more than 16 inches (406 mm) o.c. vertically and 16 inches (406 mm) o.c. horizontally, with not less than 1 anchor for each 1.77 sq. ft. (0.16 sq. m) of wall area. Install additional anchors within 12 inches (305 mm) of openings and at intervals, not exceeding 8 inches (203 mm), around the perimeter.

3.10 CONTROL AND EXPANSION JOINTS

- A. General: Install vertical control and expansion joints at one side of all doorways and at wall locations maximum 25 ft. o.c., and where indicated. Build-in related items as masonry progresses. Do not form a continuous span through movement joints unless provisions are made to prevent in-plane restraint of wall or partition movement.
- B. Form control joints in concrete masonry with preformed control-joint gaskets designed to fit standard sash block.
- C. Form expansion joints in brick made from clay or shale by building in joint fillers not less than 3/8 inch (10 mm) for installation of sealant and backer rod specified in Division 07 Section "Joint Sealants." Keep joint free and clear of mortar.
- D. Build in horizontal, pressure-relieving joints where indicated; construct joints by either leaving an air space or inserting a compressible filler of width required for installing sealant and backer rod specified in Division 07 Section "Joint Sealants."
 1. Locate horizontal, pressure-relieving joints beneath shelf angles supporting masonry veneer and attached to structure behind masonry veneer.

3.11 LINTELS

- A. Install steel lintels where indicated.

- B. Provide masonry lintels where shown and where openings of more than 12 inches (305 mm) for brick-size units and 24 inches (610 mm) for block-size units are shown without structural steel or other supporting lintels.
 - 1. Provide prefabricated or built-in-place masonry lintels. Use specially formed bond beam units with reinforcing bars placed as indicated and filled with coarse grout. Cure precast lintels before handling and installing. Temporarily support built-in-place lintels until cured.

- C. Provide minimum bearing of 8 inches (200 mm) at each jamb, unless otherwise indicated.

3.12 FLASHING, WEEP HOLES, AND VENTS

- A. General: Install embedded flashing and weep holes in masonry at shelf angles, lintels, ledges, other obstructions to downward flow of water in wall, and where indicated.
- B. Prepare masonry surfaces so they are smooth and free from projections that could puncture flashing. Unless otherwise indicated, place through-wall flashing on sloping bed of mortar and cover with mortar. Before covering with mortar, seal penetrations in flashing with adhesive, sealant, or tape as recommended by flashing manufacturer.
- C. Install flashing as follows:
 - 1. At masonry-veneer walls, apply flexible flashing over the air barrier to a height of 6" above the top of the cavity drainage material and secure flashing top edge with a termination bar to substrate. Apply sealant to top of termination bar. Install a 6" wide strip of compatible self-adhesive membrane over the installed termination bar and sealant, centered on the termination bar. Install metal drip edges beneath flexible flashing at exterior face of wall. Stop flexible flashing 1/2 inch (13 mm) back from outside face of wall, and adhere flexible flashing to top of metal drip edge
 - 2. At lintels and shelf angles, extend flashing a minimum of 4 inches (100 mm) into masonry at each end. At heads and sills, extend flashing 4 inches (100 mm) at ends and turn flashing up not less than 2 inches (50 mm) to form a pan.
 - 3. Extend sheet metal flashing 1/2 inch (13 mm) beyond face of masonry at exterior and turn flashing down to form a drip.
 - 4. Install end dams at all window and door flashing locations.
- D. Install weep holes in the head joints in exterior wythes of the first course of masonry immediately above embedded flashing and as follows:
 - 1. Use mesh weep vents to form weep holes at brick.
 - 2. Use wicking material to form weep holes above flashing under cast stone sills. Turn wicking down at lip of sill to be as inconspicuous as possible
 - 3. Space weep holes 24 inches (600 mm) o.c.
 - 4. Place cavity drainage material immediately above flashing in cavities.

- E. Install vents in vertical head joints at the top of each continuous cavity at spacing indicated. Use plastic weep hole/vents to form vents.
- F. Install reglets and nailers for flashing and other related construction where they are shown to be built into masonry.

3.13 REINFORCED UNIT MASONRY INSTALLATION

- A. General: Provide reinforced unit masonry walls at all walls as indicated.
- B. Temporary Formwork and Shores: Construct formwork and shores as needed to support reinforced masonry elements during construction.
 - 1. Construct formwork to provide shape, line, and dimensions of completed masonry as indicated. Make forms sufficiently tight to prevent leakage of mortar and grout. Brace, tie, and support forms to maintain position and shape during construction and curing of reinforced masonry.
 - 2. Do not remove forms and shores until reinforced masonry members have hardened sufficiently to carry their own weight and other temporary loads that may be placed on them during construction.
- C. Placing Reinforcement: Comply with requirements in ACI 530.1/ASCE 6/TMS 602.
- D. Grouting: Do not place grout until entire height of masonry to be grouted has attained enough strength to resist grout pressure.
 - 1. Comply with requirements in ACI 530.1/ASCE 6/TMS 602 for cleanouts and for grout placement, including minimum grout space and maximum pour height.

3.14 FIELD QUALITY CONTROL

- A. Inspectors: Owner will engage qualified certified testing agency to perform inspections and prepare reports. Allow inspectors access to scaffolding and work areas, as needed to perform inspections.
 - 1. Place grout only after inspectors have verified compliance of grout spaces and grades, sizes, and locations of reinforcement.
 - 2. Retesting of materials failing to meet specified requirements shall be done at Contractor's expense.
- B. Testing Frequency: Tests and Evaluations listed in this Article will be performed during construction for each 5000 sq. ft. (465 sq. m) of wall area or portion thereof.
- C. Mortar Test (Property Specification): For each mix provided, per ASTM C 780 . Test mortar for mortar air content and compressive strength
- D. Grout Test (Compressive Strength): For each mix provided, per ASTM C 1019.

3.15 REPAIRING, POINTING, AND CLEANING

- A. Remove and replace masonry units that are loose, chipped, broken, stained, or otherwise damaged or that do not match adjoining units. Install new units to match adjoining units; install in fresh mortar, pointed to eliminate evidence of replacement.
- B. Pointing: During the tooling of joints, enlarge voids and holes, except weep holes, and completely fill with mortar. Point up joints, including corners, openings, and adjacent construction, to provide a neat, uniform appearance. Prepare joints for sealant application.
- C. In-Progress Cleaning: Clean unit masonry as work progresses by dry brushing to remove mortar fins and smears before tooling joints.
- D. Final Cleaning: After mortar is thoroughly set and cured, clean exposed masonry as follows:
 - 1. Remove large mortar particles by hand with wooden paddles and nonmetallic scrape hoes or chisels.
 - 2. Test cleaning methods on sample wall panel; leave one-half of panel uncleaned for comparison purposes. Obtain Architect's approval of sample cleaning before proceeding with cleaning of masonry.
 - 3. Protect adjacent stone and nonmasonry surfaces from contact with cleaner by covering them with liquid strippable masking agent, polyethylene film, or waterproof masking tape.
 - 4. Wet wall surfaces with water before applying cleaners; remove cleaners promptly by rinsing the surfaces thoroughly with clear water.
 - 5. Clean concrete masonry by cleaning method indicated in NCMA TEK 8-2 applicable to type of stain on exposed surfaces.
 - 6. Clean brick masonry with a proprietary acidic cleaner applied according to manufacturer's written instructions.

END OF SECTION 042000

SECTION 044100 - STONE MASONRY VENEER

PART 1 - GENERAL

1.1 SUMMARY

- A. This Section includes:
 - 1. Stone veneer facing on concrete backup, CMU backup and metal stud wall backup at exterior walls at buildings.
 - 2. Thin stone veneer facing on concrete site walls.
 - 3. Stone veneer facing on concrete site walls.
 - 4. Mortar (adhesive) and pointing mortar for thin stone veneer.
- B. Mortar, grout, anchors, flashing, and miscellaneous masonry accessories for stone veneer are specified in Division 04 Section "Unit Masonry Assemblies."

1.2 SUBMITTALS

- A. Product Data: For setting and pointing mortars.
- B. Qualification Data: For firms and persons specified in "Quality Assurance" Article
- C. Samples for Initial Selection: For the following:
 - 1. Colored mortar samples in small-scale form showing the full range of colors and textures available for each different exposed mortar color required.
- D. Samples for Verification: For the following:
 - 1. Full-size units for each color, grade, finish, and variety of stone required, showing the full range of exposed colors, textures, and dimensions to be expected in the completed construction.
 - 2. Colored mortar samples, for each mortar color required, showing the full range expected in the finished construction.

1.3 QUALITY ASSURANCE

- A. Source Limitations for Stone: Obtain all stone for each variety of stone from single source with resources to provide materials of consistent quality in appearance and physical properties without delaying the work.
- B. Source Limitations for Mortar Materials: Obtain mortar ingredients of a uniform quality, including color for exposed masonry, from one manufacturer.

- C. Single Source Responsibility for Installation of Stone Masonry Veneer Work: All stone masonry veneer work, including installation of associated cast stone trim, shall be performed by a single firm meeting qualifications specified in this section.
 - D. Installer Qualifications for Stone Masonry Veneer Work: Work must be performed by a firm having not less than five (5) years successful experience in comparable stone masonry veneer work including work on at least three (3) buildings in the last five years and employing personnel skilled in the installation processes and operations indicated.
 - 1. Only skilled journeymen masons who are thoroughly trained and experienced in performing stone masonry veneer work including field trimming and installing and the skills required, and completely familiar with the materials and methods required shall be used for the work.
 - 2. One skilled journeyman mason shall be present at all times during execution of the work and shall personally direct the work.
 - 3. In acceptance or rejection of stone masonry veneer work, no allowance will be made for lack of skill on the part of the workmen
 - E. Mockups: Before installing stone masonry veneer work, build mockups to verify selections made under sample submittals and to demonstrate aesthetic effects and qualities of materials and execution. Final approval of exposed mortar color and texture, and stone bonding (pattern) will be made based on acceptance of mock-up. Build mockups to comply with the following requirements, using materials indicated for the completed Work:
 - 1. Locate mockup in place on building exterior wall in the locations as directed by Architect.
 - 2. Build a single mockup of stone veneer on solid backing (CMU, concrete or metal studs and gypsum sheathing as selected by Architect) approximately 96 inches long by 48 inches high by full thickness, including all accessories and cast stone trim unit. Include a sealant-filled joint at least 16 inches (400 mm) long in the mockup.
 - 3. Reprepare mock-ups until Architect has approved mock-up.
 - 4. Protect accepted mockups from the elements with weather-resistant membrane.
 - 5. Approval of mockups does not constitute approval of deviations from the Contract Documents contained in mockups unless Architect specifically approves such deviations in writing.
 - 6. Approved mock-up in undamaged condition may be incorporated in the Work.
 - F. Vertical and Lateral Fire Propagation Test Characteristics: The exterior wall assembly of the School Building is required to comply with NFPA 285 "Standard Method of Test for the Evaluation of Flammability Characteristics of Exterior Nonload-bearing Wall Assemblies Containing Combustible Components." The base wall, stud cavity insulation, wall sheathing, air barrier, continuous wall rigid insulation and exterior cladding are components that are required to be to be evaluated as part of this specific assembly test. All stone veneer components shall be part of an assembly that has passed NFPA 285 testing.
- 1.4 DELIVERY, STORAGE, AND HANDLING
- A. Store and handle stone, mortar and related materials to prevent deterioration or damage

due to moisture, temperature changes, contaminants, corrosion, breaking, chipping, or other causes.

1.5 PROJECT CONDITIONS

- A. Hot-Weather and Cold-Weather Requirements: Comply with requirements contained in Section 042000.

PART 2 - PRODUCTS

2.1 STONE SOURCES

- A. Varieties and Sources for Stone Veneer: Provide 1763 Granite from Champlain Stone LTD, or Architect approved equal.

1. Stone Depth: 3"- 5" building veneer.
2. Stone Facing Area: 1/4 sq. ft. to 3 sq. ft.
3. Stone Shape: Roughly Squared/Rectangular.
4. Individual stone sizes shall be similar to the range of sizes on the existing adjacent St. Denis Church.
5. Finish: Natural (seam) face, guilotine cut.

- B. Varieties and Sources for Thin Stone Veneer: Provide 1763 Granite from Champlain Stone LTD, or Architect approved equal.

1. Stone Depth: 3/4"- 1-1/4" sawn thin veneer.
2. Stone Facing Area: 1/4 sq. ft. to 1-1/4 sq. ft.
3. Stone Shape: Roughly Squared/Rectangular.
4. Individual stone sizes shall be similar to the range of sizes on the existing adjacent St. Denis Church.
5. Finish: Natural (seam) face, guilotine cut.
6. Provide 90 degree corners.

2.2 MORTAR AND GROUT MATERIALS FOR STONE VENEER

- A. Refer to Section 042000. Provide Type N colored mortar in color as selected by Architect.

2.3 MORTAR AND GROUT MATERIALS FOR THIN STONE VENEER

- A. Setting Mortar: Multi-use, polymer fortified adhesive mortar formulated for wall installations of interior and exterior thin brick, masonry veneer, stone, and tile. Non-sag performance, "Extra Heavy" rating per ASTM C627 (TCNA), and meets or exceeds ANSI A118.4, A118.11 and A118.15 requirements.

1. Basis of Design Product: Provide Laticrete MVIS Thin Brick Mortar or equal.

- B. Pointing Mortar: Formulated from a blend of high strength portland cement, graded aggregates, and color-fast pigments, factory prepared and designed to be mixed with

water. Designed for adhered stone, thin brick and manufactured masonry veneers

1. Basis of Design Product: Provide Laticrete MVIS Pointing Mortar, or equal.
2. Color: As selected by Architect.

2.4 MISCELLANEOUS MASONRY ACCESSORIES

- A. Refer to Section 042000 for specifications for anchors and ties, weep holes, flashing and other accessories.

2.5 MASONRY CLEANERS

- A. Job-Mixed Detergent Solution: Solution of 1/2-cup (0.14-L) dry-measure tetrasodium polyphosphate and 1/2-cup (0.14-L) dry-measure laundry detergent dissolved in 1 gal. (4 L) of water.

PART 3 - EXECUTION

3.1 EXAMINATION

- A. Examine surfaces to receive stone work and conditions under which stone work will be installed, with Installer present, for compliance with requirements for installation tolerances and other conditions affecting performance.
 1. For the record, prepare written report, endorsed by Installer, listing conditions detrimental to performance of the work.
 2. Proceed with installation only after unsatisfactory conditions have been corrected.

3.2 PREPARATION

- A. Clean dirty or stained stone surfaces by removing soil, stains, and foreign materials before setting. Clean stone by thoroughly scrubbing with fiber brushes and then drenching with clear water. Use only mild cleaning compounds that contain no caustic or harsh materials or abrasives.

3.3 SETTING OF STONE VENEER, GENERAL

- A. Comply with requirements specified in Sections 042000 as they relate to the work of this section.
- B. Sort stone before it is placed in wall to remove stone that does not comply with requirements relating to aesthetic effects, physical properties, or fabrication, or that is otherwise unsuitable for intended use.
- C. Arrange stones for accurate fit in bonding pattern as indicated
- D. Arrange stones with color and size variations uniformly dispersed for an evenly blended appearance.

- E. Set stone to comply with requirements indicated on Drawings. Install veneer anchors, supports, fasteners, and other attachments indicated or necessary to secure stone veneer assemblies in place. Set stone accurately in locations indicated with edges and faces aligned according to established relationships and indicated tolerances.
- F. Maintain uniform joint widths except for variations due to different stone sizes and where minor variations are required to maintain bond alignment, if any.
 - 1. Lay walls with narrow joint widths that accommodate stone's irregular bed shapes, and as per approved mock-ups..
- G. Provide expansion, control, and pressure-relieving joints of widths and at locations indicated.
 - 1. Keep expansion and pressure-relieving joints free of mortar and other rigid materials.
 - 2. Sealing expansion, control, and pressure-relieving joints is specified in Division 07 Section "Joint Sealants."
- H. Contiguous Work: Provide reveals, reglets, and openings as required to accommodate contiguous work.

3.4 INSTALLATION OF ADHERED STONE VENEER ASSEMBLIES

- A. Mix mortar materials in accordance with manufacturer's directions.
- B. For adhered masonry veneers use a gauging trowel to apply a thin coat of mortar to cover entire back of the veneer unit. Spread additional mortar onto the back of the skim coated veneer unit sufficient to completely fill the space between the veneer unit and the substrate when compressed against the substrate. Press the mortar covered back of the veneer against the substrate at the desired final position. Slide the unit roughly 1" diagonally from the desired final position and back into the desired position while maintaining even pressure. This should be done in such a manner as to squeeze the mortar to fill the entire space between the veneer unit and the substrate, helping to achieve 100% coverage to both the substrate and veneer unit, allowing excess mortar to extrude on all sides around the veneer unit. Clean excess extruded mortar with trowel and spread onto the next veneer unit to be installed.
- C. Maintain uniform joint widths.
- D. Point masonry veneer after appropriate curing time using pointing mortar in accordance with manufacturer's directions.

3.5 INSTALLATION OF ANCHORED STONE VENEER ASSEMBLIES

- A. Anchor stone veneer to concrete, CMU or metal stud backup with adjustable, screw-attached veneer anchors of type specified in Section 042000. Fasten backplate of anchors to concrete or CMU using expansion anchors. Embed triangular masonry tie in

mortar joints.

- B. Space anchors not more than 16 inches o.c. vertically and 24 inches o.c. horizontally. Install additional anchors within 12 inches of openings, sealant joints, and perimeter at intervals not exceeding 12 inches
- C. Set stone in full bed of mortar with full head joints, unless otherwise indicated. Build veneer anchors into mortar joints as stone is set.
- D. Embed veneer anchors in mortar joints of stone masonry at least halfway, but not less than 1-1/2 inches, through stone masonry and with at least a 5/8-inch cover on exterior face.
- E. Provide 1-inch cavity between stone masonry and backup construction unless otherwise indicated. Keep cavity free of mortar droppings and debris.
- F. Refer to Section 042000 for additional installation specifications including installation of flashings, weep holes, etc.
- G. Maintain uniform joint widths.
- H. Tool exposed joints to a flat, smooth profile when thumbprint hard, using a jointer larger than the joint thickness, to match approved mock-ups.

3.6 INSTALLATION TOLERANCES

- A. Refer to Section 042000.

3.7 ADJUSTING AND CLEANING

- A. Remove and replace stone veneer assemblies of the following description:
 - 1. Broken, chipped, stained, or otherwise damaged stone. Stone may be repaired if methods and results are approved by Architect.
 - 2. Defective joints.
 - 3. Stone veneer assemblies not matching approved samples and mockups.
 - 4. Stone veneer assemblies not complying with other requirements indicated.
- B. Replace in a manner that results in stone veneer assemblies matching approved samples and mockups, complying with other requirements, and showing no evidence of replacement.
- C. In-Progress Cleaning: Clean stone as work progresses. Remove mortar fins and smears before tooling joints.
- D. Clean stone after pointing mortar and sealant has had opportunity to cure, using clean water and stiff-bristle fiber brushes. Do not use wire brushes, acid-type cleaning agents, cleaning agents containing caustic compounds or abrasives, or other materials or methods that could damage stone.

3.8 PROTECTION

- A. Protection: Provide final protection in a manner acceptable to Architect that ensures cut stone work is without damage and deterioration at the time of final acceptance.

END OF SECTION 044100

The following additions, substitutions, or clarifications are extracted from the (5) Bid Addenda issued with this project during bidding. This insert is intended to summarize addendum information relevant to this specification section. See Bid Addenda issued by the City of Yonkers for complete contract document changes.

Bid Addendum No. 4:

Add note regarding cast stone lintels:

1.3-A-2: Design connection of precast units to structural backup. All cast stone lintels shall be designed to carry the dead load of the exterior masonry above as well as self-weight. Refer to Structural Drawings and loads specified herein for minimum connection requirements.

SECTION 047200 – CAST STONE

PART 1 - GENERAL

1.1 SUMMARY

A. This Section includes the following:

1. Cast stone sills, copings, trim, caps, and other shapes indicated on drawings.
2. Cast stone wall panels, for interior and exterior locations.
3. Cast stone date stone with metal time capsule box.
4. Steel and stainless steel support and retention connections for cast stone, including all ties, anchors, and necessary shims to supporting structure.
5. Engineered anchoring designs and connections, by a professional engineer employed by the Contractor.

B. Related Sections:

1. Division 04 Section "Unit Masonry" for mortar and grout.

1.2 DEFINITIONS

A. Cast Stone: Architectural precast concrete building units intended to simulate natural cut stone.

B. Arris: The sharp edge of a Cast Stone Unit.

1.3 SYSTEM PERFORMANCE REQUIREMENTS

A. General: Engineer, design, fabricate and erect the precast units and supports to withstand loads from winds, gravity, seismic, structural movement including movement thermally induced, and to resist in-service use conditions that the units will experience, including exposure to the weather, without failure.

1. Design each member to withstand stresses resulting from combinations of loads that produce the maximum allowable stresses in that member.
2. Design connection of precast units to structural backup. Refer to structural drawings and loads specified herein for minimum connection requirements.

B. Design Loads: Basic design loads include live loads, wind loads, and seismic load, in addition to the dead load.

1. Comply with requirements indicated on structural drawings.

1.4 ACTION SUBMITTALS

- A. Product Data: Include construction details, material descriptions, dimensions of individual components and profiles, and finishes for cast stone units.
- B. Design Mixes: For each different mix.
- C. Shop Drawings: Prepared by or under supervision of a qualified professional engineer. Detail fabrication and installation of cast stone units. Indicate member locations, plans, elevations, dimensions, shapes, cross sections, limits of each finish, and types of reinforcement, including special reinforcement, and lifting devices necessary for handling and erection.
 - 1. Include building elevations showing layout of units and locations of joints and anchors
 - 2. Indicate locations and details of anchorage devices to be embedded in other construction.
 - 3. Include erection procedure for precast units, sequence of erection, and erection tolerances.
 - 4. Include full-size detail of inscription for date stone.
 - 5. Provide complete design calculations, including loads imposed on structure, stamped and signed by qualified professional engineer.
- D. Samples for Initial Selection: For colored mortar, showing the full range of colors available.
- E. Samples for Verification:
 - 1. For each mortar color required, showing the full range expected in the finished construction. Make samples using the same sand and mortar ingredients to be used on Project. Label samples to indicate type and amount of colorant used.
 - 2. For each color and texture of cast stone required, 10-inches (250 mm) square in size.
- F. Full-Size Samples: For each type of cast stone trim unit required. Make available for Architect's review at Project site before installing cast stone.
 - 1. Approved Samples may be installed in the Work.

1.5 INFORMATIONAL SUBMITTALS

- A. Qualification Data: For Fabricator and Professional Engineer.
- B. Material Test Reports: From a qualified testing agency indicating and interpreting test results for compliance of cast stone with requirements indicated.
- C. Certification that the materials incorporated in this Work are free from hazardous contaminants.

1.6 QUALITY ASSURANCE

- A. Fabricator Qualifications: A firm experienced in manufacturing cast stone units similar to those indicated for this Project and with a record of successful in-service performance, as well as sufficient production capacity to manufacture required units.
 - 1. Fabricator shall assume responsibility for engineering cast stone units to comply with performance requirements. This responsibility includes preparation of Shop Drawings and comprehensive engineering analysis by a qualified professional engineer.
 - 2. Fabricator is a producing member of the Cast Stone Institute
- B. Professional Engineer Qualifications: A professional engineer who is legally qualified to practice in the location of the Project and who is experienced in providing engineering services of the kind indicated. Engineering services are defined as those performed for installations of cast stone units that are similar to those indicated for this Project in material, design, and extent.
- C. Testing Agency Qualifications: An independent testing agency qualified according to ASTM E 329 to conduct the testing indicated, as documented according to ASTM E 548.
- D. Source Limitations for Cast Stone: Obtain cast stone units through one source from a single manufacturer.
- E. Source Limitations for Mortar Materials: Obtain mortar ingredients of a uniform quality, including color, from one manufacturer for each cementitious component and from one source or producer for each aggregate.
- F. Mock-ups for Trim Units: Incorporate cast stone units in mock-up specified in Division 04 Section "Unit Masonry".
- G. Mock-ups for Panels: Prior to installing cast stone wall panels, construct mockups for each form of construction and finish required to verify selections made under Sample submittals and to demonstrate aesthetic effects as well as qualities of materials and execution. Build mockups to comply with the following requirements, using materials indicated for Work.
 - 1. Locate mockups on-site in the location and of the size indicated or, if not indicated, as directed by Architect.
 - a. Interior wall panel mock-up shall be in place and exterior wall panel mock-up shall be standalone.
 - 2. Include exposed sealant joint in mock-up.
 - 3. Notify Architect 7 days in advance of the dates and times when mockups will be constructed.
 - 4. Demonstrate the proposed range of aesthetic effects and workmanship.
 - 5. Obtain Architect's approval of mockups before start of Work.
 - 6. Retain and maintain mockups during construction in an undisturbed condition as a standard for judging the completed Work.
 - 7. Demolish and remove exterior mock-ups at the completion of the Work.

8. Interior mock-up in undamaged condition may be incorporated in the Work.

H. Preinstallation Conference: Conduct conference at Project site to comply with requirements in Division 01 Section "Project Coordination."

I. Vertical and Lateral Fire Propagation Test Characteristics: The exterior wall assembly of the Classroom Building is required to comply with NFPA 285 "Standard Method of Test for the Evaluation of Flammability Characteristics of Exterior Nonload-bearing Wall Assemblies Containing Combustible Components." The base wall, stud cavity insulation, wall sheathing, air barrier, continuous wall rigid insulation and exterior cladding are components that are required to be to be evaluated as part of this specific assembly test. Cast stone shall be part of an assembly that has passed NFPA 285 testing.

1.7 DELIVERY, STORAGE, AND HANDLING

A. Pack, handle, and ship cast stone units in suitable packs or pallets.

1. Lift with wide-belt slings; do not use wire rope or ropes that might cause staining. Move cast stone units, if required, using dollies with wood supports.
2. Store cast stone units on wood skids or pallets with nonstaining, waterproof covers. Arrange to distribute weight evenly and to prevent damage to units. Ventilate under covers to prevent condensation.

B. Store installation materials on elevated platforms, under cover, and in a dry location.

C. Store mortar aggregates where grading and other required characteristics can be maintained and contamination avoided.

1.8 COORDINATION

A. Coordinate production and delivery of cast stone with unit masonry work to minimize the need for on-site storage and to avoid delaying the Work.

B. Furnish anchorage items to be embedded in or attached to other construction without delaying the Work. Provide setting diagrams, templates, instructions, and directions, as required, for installation.

PART 2 - PRODUCTS

2.1 MANUFACTURERS

A. Manufacturer: Provide products manufactured by one of the following:

1. Arriscraft
2. American ArtStone.
3. Continental Cast Stone Manufacturing, Inc.
4. Corinthian Cast Stone
5. Stone Legends Inc.

2.2 CAST STONE MATERIALS

- A. General: Comply with ASTM C 1364 and the following:
- B. Portland Cement: ASTM C 150, Type I, containing not more than 0.60 percent total alkali when tested according to ASTM C 114.
- C. Coarse Aggregates: Granite, quartz, or limestone complying with ASTM C 33; gradation as needed to produce required textures.
- D. Fine Aggregates: Manufactured or natural sands complying with ASTM C 33, gradation as needed to produce required textures.
- E. Color Pigment: ASTM C 979, synthetic mineral-oxide pigments or colored water-reducing admixtures; color stable, free of carbon black, nonfading, and resistant to lime and other alkalis.
- F. Reinforcement: Deformed steel bars complying with ASTM A 615/A 615M.
 - 1. Epoxy Coating: ASTM A 775/A 775M.
 - 2. Galvanized Coating: ASTM A 767/A 767M.
- G. Embedded Anchors and Other Inserts: Fabricated from stainless steel complying with ASTM A 276 or ASTM A 666, Type 304.

2.3 STEEL SUPPORT AND CONNECTION MATERIALS

- A. Carbon-Steel Shapes: ASTM A 36. Steel shapes shall meet the requirements of ASTM A992 (50 ksi steel).
- B. Carbon-Steel Plate: Structural quality, hot-rolled carbon steel, ASTM A 283, Grade C.
- C. Electrodes for Welding: Comply with AWS code and ASTM A 232, E70XX Electrodes, Low Hydrogen.
- D. Finish: For exterior steel items, steel in exterior walls, exposed units, and items indicated for galvanizing, apply zinc coating by hot-dip process according to ASTM A 123/A 123M, after fabrication, and ASTM A 153/A 153M, as applicable. For inserts cast into precast units, provide hot-dipped galvanized, electrogalvanized, or cadmium coated finish. For all other items, provide shop painting with rust-inhibitive primer.

2.4 STAINLESS-STEEL SUPPORT AND CONNECTION MATERIALS

- A. Anchors: Stainless steel, ASTM A 666, Type 304, of temper and diameter required to support loads without exceeding allowable design stresses.
- B. Accessories: Provide clips, hangers, plastic shims, and other accessories required to install cast stone units.

- C. Provide stainless steel support and connection materials for exterior cast stone, unless otherwise indicated on Drawings.

2.5 CAST STONE UNITS

- A. Provide cast stone units complying with ASTM C 1364.
 - 1. Provide units that are resistant to freezing and thawing as determined by laboratory testing according to ASTM C 666, Procedure A, as modified by ASTM C 1364.
- B. Physical Properties:
 - 1. Compressive Strength: Minimum 6,500 psi when tested per ASTM C 1194.
 - 2. Absorption: Maximum 6% when tested per ASTM C 1195.
 - 3. Freeze Thaw: Maximum 5% when tested per C1364.
 - 4. Unit Density: Minimum 130 pcf when tested per ASTM C642.
 - 5. Cast stone units installed at grade shall be suitable for use at or below grade.
- C. Reinforce units as indicated and as required by ASTM C 1364. Use galvanized or epoxy-coated reinforcement when covered with less than 1-1/2 inches (38 mm) of material. Minimum coverage shall be twice the diameter of the bars.
 - 1. Area of reinforcement in panels greater than 12" wide shall be not less than 1/4 percent of the cross section area when steel is specified.
- D. Fabrication Method: Use a Vibrant-Tamp placement method or machine manufacture using a zero slump mixture to achieve desired appearance and physical properties.
- E. Fabricate units with sharp arris and details accurately reproduced with indicated texture on all exposed surfaces, unless otherwise indicated.
 - 1. Slope exposed horizontal surfaces at least 1:12, unless otherwise indicated.
 - 2. Provide raised fillets at backs of sills and at ends indicated to be built into jambs.
 - 3. Provide drips on projecting elements, unless otherwise indicated.
- F. Fabricate date stone with inscription with lettering style and size and message content as selected by the Architect.
- G. Fabricate panels and trim members to size, shape and thicknesses indicated on Drawings for each application.
 - 1. Exterior wall panels shall be full-depth (3-5/8") thickness minimum and interior wall panels shall be 1-1/4" thickness minimum, unless otherwise indicated on Drawings.
- H. Cure and finish units as follows:

1. Cure units in totally enclosed curing room under dense fog and water spray at 95 percent relative humidity for 24 hours.
 2. Yard cure units until the sum of the mean daily temperatures for each day equals or exceeds 350 deg F.
 3. Acid etch units to remove cement film from surfaces indicated to be finished.
- I. Color and Texture: Exposed surfaces shall exhibit a fine-grained texture similar to natural stone; no bug-holes or air voids shall be permitted.
1. Color and Texture: Smooth texture, and color matching Corinthian Cast Stone "Light Grey Limestone."

2.6 MORTAR MATERIALS

- A. Provide mortar materials that comply with Division 04 Section "Unit Masonry."

2.7 ACCESSORIES

- A. Anchors for Cast Stone Trim: Units fabricated with tabs or dowels designed to engage kerfs or holes in cast stone trim units and holes for fastening to framing of type as indicated, size as required for project conditions, fabricated from stainless steel complying with ASTM A 276 or ASTM A 666, Type 304.
- B. Dowels: Round stainless-steel bars complying with ASTM A 276, Type 304, 1/2-inch (12-mm) diameter.
- C. Cast Stone Cleaner: Sure Kleen #600 by ProSoCo Products Inc., or equal.
- D. Through wall flashing, weep wicks and other accessories are specified in Division 04 Section "Unit Masonry."

2.8 MORTAR MIXES

- A. Provide ASTM C 270, Type N colored mortar. Comply with requirements in Division 04 Section "Unit Masonry" for mortar mixes.

2.9 SOURCE QUALITY CONTROL

- A. Employ an independent testing agency to sample and test cast stone units according to ASTM C 1364.
1. Include testing for freezing and thawing resistance.

PART 3 - EXECUTION

3.1 EXAMINATION

- A. Examine substrates and conditions, with Installer present, for compliance with requirements for installation tolerances and other conditions affecting performance of cast stone.
- B. Proceed with installation only after unsatisfactory conditions have been corrected.

3.2 INSTALLATION

- A. General: Comply with Cast Stone Institute recommendation for installation of cast stone units.
- B. Set cast stone as indicated on Contract Drawings. Install anchors, supports, fasteners, and other attachments indicated or necessary to secure units in place. Set units accurately in locations indicated with edges and faces aligned according to established relationships and indicated tolerances.
- C. Anchor cast stone panels in position by bolting, welding, grouting, or as otherwise indicated. Remove temporary shims, wedges, and spacers as soon as possible after anchoring and grouting are completed.
- D. Drench units with clear water just before setting.
- E. Set units in full bed of mortar with full head joints, unless otherwise indicated. Build anchors and ties into mortar joints as units are set.
 - 1. Fill dowel holes and anchor slots with mortar.
 - 2. Fill collar joint solid as units are set.
 - 3. Build concealed flashing into mortar joints as units are set.
 - 4. Leave head joints open in coping and other units with exposed horizontal surfaces. Keep joints clear of mortar, and rake out to receive sealant.
- F. Rake out joints for pointing with mortar to depths of not less than 3/4 inch (19 mm). Rake joints to uniform depths with square bottoms and clean sides. Scrub faces of units to remove excess mortar as joints are raked.
- G. Point mortar joints by placing and compacting mortar in layers not greater than 3/8 inch (10 mm). Compact each layer thoroughly and allow to become thumbprint hard before applying next layer.
- H. Tool exposed joints slightly concave when thumbprint hard, using a jointer larger than joint thickness, unless otherwise indicated.
- I. Provide expansion, control, and pressure-relieving joints of widths and at locations indicated.
 - 1. Sealing joints is specified in Division 07 Section "Joint Sealants."
 - 2. Keep joints free of mortar and other rigid materials.

3.3 INSTALLATION TOLERANCES

- A. Variation from Plumb: Do not exceed 1/8 inch in 10 feet (3 mm in 3 m) or 1/4 inch in 20 feet (6 mm in 6 m) or more.
- B. Variation from Level: Do not exceed 1/8 inch in 10 feet (3 mm in 3 m), 1/4 inch in 20 feet (6 mm in 6 m), or 3/8 inch (9 mm) maximum.
- C. Variation in Joint Width: Do not vary joint thickness more than 1/8 inch in 36 inches (3 mm in 900 mm) or one-fourth of nominal joint width, whichever is less.
- D. Variation in Plane between Adjacent Surfaces (Lipping): Do not exceed 1/16-inch (1.5-mm) difference between planes of adjacent units or adjacent surfaces indicated to be flush with units.

3.4 ADJUSTING AND CLEANING

- A. Remove and replace stained and otherwise damaged units and units not matching approved Samples. Cast stone may be repaired if methods and results are approved by Architect.
- B. Replace units in a manner that results in cast stone matching approved Samples, complying with other requirements, and showing no evidence of replacement.
- C. In-Progress Cleaning: Clean cast stone as work progresses. Remove mortar fins and smears before tooling joints.
- D. Final Cleaning: After mortar is thoroughly set and cured, clean exposed cast stone as follows:
 - 1. Remove large mortar particles by hand with wooden paddles and nonmetallic scrape hoes or chisels.
 - 2. Protect adjacent surfaces from contact with cleaner by covering them with liquid strippable masking agent, polyethylene film, or waterproof masking tape.
 - 3. Wet wall surfaces with water before applying cleaners; remove cleaners promptly by rinsing thoroughly with clear water.
 - 4. Clean cast stone in conformance cleaner manufacturer's directions.

END OF SECTION 047200

SECTION 051200 - STRUCTURAL STEEL FRAMING

PART 1 - GENERAL

1.1 RELATED DOCUMENTS

- A. Drawings and general provisions of the Contract, including General and Supplementary Conditions and Division 01 Specification Sections, apply to this Section.

1.2 SUMMARY

- A. Section Includes:

1. Structural steel.
2. Field-installed shear connectors.
3. Grout.

- B. Related Requirements:

1. Section 053100 "Steel Decking" for field installation of shear connectors through deck.
2. Section 055000 "Metal Fabrications" for steel lintels and shelf angles not attached to structural-steel frame miscellaneous steel fabrications and other steel items not defined as structural steel.
3. Section 099113 "Exterior Painting" and Section 099123 "Interior Painting" for surface-preparation and priming requirements.

1.3 COORDINATION

- A. Coordinate selection of shop primers with topcoats to be applied over them. Comply with paint and coating manufacturers' written recommendations to ensure that shop primers and topcoats are compatible with one another.
- B. Coordinate installation of anchorage items to be embedded in or attached to other construction without delaying the Work. Provide setting diagrams, sheet metal templates, instructions, and directions for installation.

1.4 PREINSTALLATION MEETINGS

- A. Preinstallation Conference: Conduct conference at Project site.

1.5 ACTION SUBMITTALS

- A. Product Data: For each type of product.

- B. Shop Drawings: Show fabrication of structural-steel components.
 - 1. Include details of cuts, connections, splices, camber, holes, and other pertinent data.
 - 2. Include embedment Drawings.
 - 3. Indicate welds by standard AWS symbols, distinguishing between shop and field welds, and show size, length, and type of each weld. Show backing bars that are to be removed and supplemental fillet welds where backing bars are to remain.
 - 4. Indicate type, size, and length of bolts, distinguishing between shop and field bolts.
- C. Welding Procedure Specifications (WPSs) and Procedure Qualification Records (PQRs).
- D. Delegated-Design Submittal: For structural-steel connections indicated to comply with design loads, include analysis data signed and sealed by the qualified professional engineer responsible for their preparation.

1.6 INFORMATIONAL SUBMITTALS

- A. Welding certificates.
- B. Paint Compatibility Certificates: From manufacturers of topcoats applied over shop primers, certifying that shop primers are compatible with topcoats.
- C. Mill test reports for structural steel, including chemical and physical properties.
- D. Product Test Reports: For the following:
 - 1. Bolts, nuts, and washers including mechanical properties and chemical analysis.
 - 2. Direct-tension indicators.
 - 3. Tension-control, high-strength, bolt-nut-washer assemblies.
 - 4. Shear stud connectors.
 - 5. Shop primers.
 - 6. Nonshrink grout.
- E. Field quality-control and special inspection reports.

1.7 QUALITY ASSURANCE

- A. Fabricator Qualifications: A qualified fabricator that participates in the AISC Quality Certification Program and is designated an AISC-Certified Plant, Category STD, or is accredited by the IAS Fabricator Inspection Program for Structural Steel (AC 172).
- B. Installer Qualifications: A qualified installer who participates in the AISC Quality Certification Program and is designated an AISC-Certified Erector, Category ACSE.

- C. Shop-Painting Applicators: Qualified according to AISC's Sophisticated Paint Endorsement P1 or to SSPC-QP 3, "Standard Procedure for Evaluating Qualifications of Shop Painting Applicators."
- D. Welding Qualifications: Qualify procedures and personnel according to AWS D1.1/D1.1M, "Structural Welding Code - Steel."
 - 1. Welders and welding operators performing work on bottom-flange, demand-critical welds shall pass the supplemental welder qualification testing, as required by AWS D1.8/D1.8M. FCAW-S and FCAW-G shall be considered separate processes for welding personnel qualification.
- E. Comply with applicable provisions of the following specifications and documents:
 - 1. AISC 303.
 - 2. AISC 341 and AISC 341s1.
 - 3. AISC 360.
 - 4. RCSC's "Specification for Structural Joints Using ASTM A 325 or A 490 Bolts."

1.8 DELIVERY, STORAGE, AND HANDLING

- A. Store materials to permit easy access for inspection and identification. Keep steel members off ground and spaced by using pallets, dunnage, or other supports and spacers. Protect steel members and packaged materials from corrosion and deterioration.
 - 1. Do not store materials on structure in a manner that might cause distortion, damage, or overload to members or supporting structures. Repair or replace damaged materials or structures as directed.
- B. Store fasteners in a protected place in sealed containers with manufacturer's labels intact.
 - 1. Fasteners may be repackaged provided Owner's testing and inspecting agency observes repackaging and seals containers.
 - 2. Clean and relubricate bolts and nuts that become dry or rusty before use.
 - 3. Comply with manufacturers' written recommendations for cleaning and lubricating ASTM F 1852 fasteners and for retesting fasteners after lubrication.

PART 2 - PRODUCTS

2.1 PERFORMANCE REQUIREMENTS

- A. Connections: Provide details of connections required by the Contract Documents to be selected or completed by structural-steel fabricator, including comprehensive

engineering analysis by a qualified professional engineer, to withstand loads indicated and comply with other information and restrictions indicated.

- B. Moment Connections: Type FR, fully restrained.

2.2 STRUCTURAL-STEEL MATERIALS

- A. All Shapes: As indicated on drawings.

2.3 BOLTS, CONNECTORS, AND ANCHORS

- A. All bolts and anchors: As indicated on drawings.

2.4 PRIMER

- A. Primer: Fabricator's standard lead- and chromate-free, nonasphaltic, rust-inhibiting primer complying with MPI#79 and compatible with topcoat.

2.5 GROUT

- A. Nonmetallic, Shrinkage-Resistant Grout: ASTM C 1107/C 1107M, factory-packaged, nonmetallic aggregate grout, noncorrosive and nonstaining, mixed with water to consistency suitable for application and a 30-minute working time.

2.6 FABRICATION

- A. Structural Steel: Fabricate and assemble in shop to greatest extent possible. Fabricate according to AISC 303, "Code of Standard Practice for Steel Buildings and Bridges," and to AISC 360.
 1. Fabricate beams with rolling camber up.
 2. Mark and match-mark materials for field assembly.
 3. Complete structural-steel assemblies, including welding of units, before starting shop-priming operations.
- B. Thermal Cutting: Perform thermal cutting by machine to greatest extent possible.
 1. Plane thermally cut edges to be welded to comply with requirements in AWS D1.1/D1.1M.
- C. Bolt Holes: Cut, drill, mechanically thermal cut, or punch standard bolt holes perpendicular to metal surfaces.
- D. Finishing: Accurately finish ends of columns and other members transmitting bearing loads.

- E. Cleaning: Clean and prepare steel surfaces that are to remain unpainted as indicated on drawing notes.
- F. Shear Connectors: Prepare steel surfaces as recommended by manufacturer of shear connectors. Use automatic end welding of headed-stud shear connectors according to AWS D1.1/D1.1M and manufacturer's written instructions.
- G. Holes: Provide holes required for securing other work to structural steel and for other work to pass through steel members.
 - 1. Cut, drill, or punch holes perpendicular to steel surfaces.
 - 2. Baseplate Holes: Cut, drill, mechanically thermal cut, or punch holes perpendicular to steel surfaces.
 - 3. Weld threaded nuts to framing and other specialty items indicated to receive other work.

2.7 SHOP CONNECTIONS

- A. High-Strength Bolts: Shop install high-strength bolts according to RCSC's "Specification for Structural Joints Using ASTM A 325 or A 490 Bolts" for type of bolt and type of joint specified.
 - 1. Joint Type: Snug tightened, use Slip Critical bolts at bolted moment connections.
- B. Weld Connections: Comply with AWS D1.1/D1.1M for tolerances, appearances, welding procedure specifications, weld quality, and methods used in correcting welding work.
 - 1. Assemble and weld built-up sections by methods that maintain true alignment of axes without exceeding tolerances in AISC 303 for mill material.

2.8 SHOP PRIMING

- A. Shop prime steel surfaces except the following:
 - 1. Surfaces embedded in concrete or mortar. Extend priming of partially embedded members to a depth of 2 inches (50 mm).
 - 2. Surfaces to be field welded.
 - 3. Surfaces of high-strength bolted, slip-critical connections.
 - 4. Surfaces to receive sprayed fire-resistive materials (applied fireproofing).
 - 5. Galvanized surfaces.
 - 6. Surfaces enclosed in interior construction.
- B. Surface Preparation: Clean surfaces to be painted. Remove loose rust and mill scale and spatter, slag, or flux deposits. Prepare surfaces according to the following specifications and standards indicated on drawing notes.

- C. Priming: Immediately after surface preparation, apply primer according to manufacturer's written instructions and at rate recommended by SSPC to provide a minimum dry film thickness of 1.5 mils (0.038 mm). Use priming methods that result in full coverage of joints, corners, edges, and exposed surfaces.
 - 1. Stripe paint corners, crevices, bolts, welds, and sharp edges.
 - 2. Apply two coats of shop paint to surfaces that are inaccessible after assembly or erection. Change color of second coat to distinguish it from first.

2.9 GALVANIZING

- A. Hot-Dip Galvanized Finish: Apply zinc coating by the hot-dip process to structural steel according to ASTM A 123/A 123M.
 - 1. Fill vent and drain holes that are exposed in the finished Work unless they function as weep holes, by plugging with zinc solder and filing off smooth.
 - 2. Galvanize lintels shelf angles and all other steel exposed to weather.

2.10 SOURCE QUALITY CONTROL

- A. Testing Agency: Owner will engage a qualified testing agency to perform shop tests and inspections.
 - 1. Provide testing agency with access to places where structural-steel work is being fabricated or produced to perform tests and inspections.
- B. Bolted Connections: Inspect shop-bolted connections according to RCSC's "Specification for Structural Joints Using ASTM A 325 or A 490 Bolts."
- C. Welded Connections: Visually inspect shop-welded connections according to AWS D1.1/D1.1M and the following inspection procedures, at testing agency's option:
 - 1. Liquid Penetrant Inspection: ASTM E 165.
 - 2. Magnetic Particle Inspection: ASTM E 709; performed on root pass and on finished weld. Cracks or zones of incomplete fusion or penetration are not accepted.
 - 3. Ultrasonic Inspection: ASTM E 164.
 - 4. Radiographic Inspection: ASTM E 94.
- D. Prepare test and inspection reports.

PART 3 - EXECUTION

3.1 EXAMINATION

- A. Verify, with certified steel erector present, elevations of concrete- and masonry-bearing surfaces and locations of anchor rods, bearing plates, and other embedments for compliance with requirements.
 - 1. Prepare a certified survey of existing conditions. Include bearing surfaces, anchor rods, bearing plates, and other embedments showing dimensions, locations, angles, and elevations.
- B. Proceed with installation only after unsatisfactory conditions have been corrected.

3.2 PREPARATION

- A. Provide temporary shores, guys, braces, and other supports during erection to keep structural steel secure, plumb, and in alignment against temporary construction loads and loads equal in intensity to design loads. Remove temporary supports when permanent structural steel, connections, and bracing are in place unless otherwise indicated.
 - 1. Do not remove temporary shoring supporting composite deck construction until cast-in-place concrete has attained its design compressive strength.

3.3 ERECTION

- A. Set structural steel accurately in locations and to elevations indicated and according to AISC 303 and AISC 360.
- B. Baseplates Bearing Plates and Leveling Plates: Clean concrete- and masonry-bearing surfaces of bond-reducing materials, and roughen surfaces prior to setting plates. Clean bottom surface of plates.
 - 1. Set plates for structural members on wedges, shims, or setting nuts as required.
 - 2. Weld plate washers to top of baseplate.
 - 3. Snug-tighten anchor rods after supported members have been positioned and plumbed. Do not remove wedges or shims but, if protruding, cut off flush with edge of plate before packing with grout.
 - 4. Promptly pack grout solidly between bearing surfaces and plates so no voids remain. Neatly finish exposed surfaces; protect grout and allow to cure. Comply with manufacturer's written installation instructions for shrinkage-resistant grouts.
- C. Maintain erection tolerances of structural steel within AISC 303, "Code of Standard Practice for Steel Buildings and Bridges."

- D. Align and adjust various members that form part of complete frame or structure before permanently fastening. Before assembly, clean bearing surfaces and other surfaces that are in permanent contact with members. Perform necessary adjustments to compensate for discrepancies in elevations and alignment.
 - 1. Level and plumb individual members of structure.
 - 2. Make allowances for difference between temperature at time of erection and mean temperature when structure is completed and in service.
- E. Splice members only where indicated.
- F. Do not use thermal cutting during erection unless approved by Architect. Finish thermally cut sections within smoothness limits in AWS D1.1/D1.1M.
- G. Do not enlarge unfair holes in members by burning or using drift pins. Ream holes that must be enlarged to admit bolts.
- H. Shear Connectors: Prepare steel surfaces as recommended by manufacturer of shear connectors. Use automatic end welding of headed-stud shear connectors according to AWS D1.1/D1.1M and manufacturer's written instructions.

3.4 FIELD CONNECTIONS

- A. High-Strength Bolts: Install high-strength bolts according to RCSC's "Specification for Structural Joints Using ASTM A 325 or A 490 Bolts" for type of bolt and type of joint specified.
 - 1. Joint Type: Snug tightened, provide Slip critical bolts at bolted moment connections.
- B. Weld Connections: Comply with AWS D1.1/D1.1M for tolerances, appearances, welding procedure specifications, weld quality, and methods used in correcting welding work.
 - 1. Comply with AISC 303 and AISC 360 for bearing, alignment, adequacy of temporary connections, and removal of paint on surfaces adjacent to field welds.
 - 2. Remove backing bars or runoff tabs, back gouge, and grind steel smooth.
 - 3. Assemble and weld built-up sections by methods that maintain true alignment of axes without exceeding tolerances in AISC 303, "Code of Standard Practice for Steel Buildings and Bridges," for mill material.

3.5 FIELD QUALITY CONTROL

- A. Special Inspections: Owner will engage a qualified special inspector to perform the following special inspections:
 - 1. Verify structural-steel materials and inspect steel frame joint details.
 - 2. Verify weld materials and inspect welds.
 - 3. Verify connection materials and inspect high-strength bolted connections.

- B. Testing Agency: Owner will engage a qualified testing agency to perform tests and inspections.
- C. Bolted Connections: Inspect bolted connections according to RCSC's "Specification for Structural Joints Using ASTM A 325 or A 490 Bolts."
- D. Welded Connections: Visually inspect field welds according to AWS D1.1/D1.1M.
 - 1. In addition to visual inspection, test and inspect field welds according to AWS D1.1/D1.1M and the following inspection procedures, at testing agency's option:
 - a. Liquid Penetrant Inspection: ASTM E 165.
 - b. Magnetic Particle Inspection: ASTM E 709; performed on root pass and on finished weld. Cracks or zones of incomplete fusion or penetration are not accepted.
 - c. Ultrasonic Inspection: ASTM E 164.
 - d. Radiographic Inspection: ASTM E 94.

3.6 REPAIRS AND PROTECTION

- A. Galvanized Surfaces: Clean areas where galvanizing is damaged or missing and repair galvanizing to comply with ASTM A 780/A 780M.
- B. Touchup Painting: Immediately after erection, clean exposed areas where primer is damaged or missing and paint with the same material as used for shop painting to comply with SSPC-PA 1 for touching up shop-painted surfaces.
 - 1. Clean and prepare surfaces by SSPC-SP 2 hand-tool cleaning or SSPC-SP 3 power-tool cleaning.
- C. Touchup Painting: Cleaning and touchup painting are specified in Section 099113 "Exterior Painting" and Section 099123 "Interior Painting."
- D. Touchup Priming: Cleaning and touchup priming are specified in Section 099600 "High-Performance Coatings."

END OF SECTION 051200

SECTION 053100 - STEEL DECKING

PART 1 - GENERAL

1.1 RELATED DOCUMENTS

- A. Drawings and general provisions of the Contract, including General and Supplementary Conditions and Division 01 Specification Sections, apply to this Section.

1.2 SUMMARY

- A. Section Includes:

1. Roof deck.
2. Acoustical roof deck.
3. Composite floor deck.

- B. Related Requirements:

1. Section 033000 "Cast-in-Place Concrete" for normal-weight and lightweight structural concrete fill over steel deck.
2. Section 051200 "Structural Steel Framing" for shop- and field-welded shear connectors.
3. Section 055000 "Metal Fabrications" for framing deck openings with miscellaneous steel shapes.
4. Section 099113 "Exterior Painting" for repair painting of primed deck and finish painting of deck.
5. Section 099123 "Interior Painting" for repair painting of primed deck and finish painting of deck.

1.3 ACTION SUBMITTALS

- A. Product Data: For each type of deck, accessory, and product indicated.

- B. Shop Drawings:

1. Include layout and types of deck panels, anchorage details, reinforcing channels, pans, cut deck openings, special jointing, accessories, and attachments to other construction.

1.4 INFORMATIONAL SUBMITTALS

- A. Welding certificates.

- B. Product Certificates: For each type of steel deck.
- C. Product Test Reports: For tests performed by a qualified testing agency, indicating that each of the following complies with requirements:
 - 1. Power-actuated mechanical fasteners.
- D. Field quality-control reports.

1.5 QUALITY ASSURANCE

- A. Testing Agency Qualifications: Qualified according to ASTM E 329 for testing indicated.
- B. Welding Qualifications: Qualify procedures and personnel according to AWS D1.3/D1.3M, "Structural Welding Code - Sheet Steel."

1.6 DELIVERY, STORAGE, AND HANDLING

- A. Protect steel deck from corrosion, deformation, and other damage during delivery, storage, and handling.
- B. Stack steel deck on platforms or pallets and slope to provide drainage. Protect with a waterproof covering and ventilate to avoid condensation.
 - 1. Protect and ventilate acoustical cellular roof deck with factory-installed insulation to maintain insulation free of moisture.

PART 2 - PRODUCTS

2.1 PERFORMANCE REQUIREMENTS

- A. AISI Specifications: Comply with calculated structural characteristics of steel deck according to AISI's "North American Specification for the Design of Cold-Formed Steel Structural Members."

2.2 ROOF DECK AND ACOUSTICAL ROOF DECK

- A. Manufacturers: Subject to compliance with requirements, available manufacturers offering products that may be incorporated into the Work include, but are not limited to the following:
 - 1. Canam Steel Corporation; Canam Group, Inc.
 - 2. Nucor Corp.

- B. Roof Deck and Acoustical Roof Deck: Fabricate panels, without top-flange stiffening grooves, to comply with "SDI Specifications and Commentary for Steel Roof Deck," in SDI Publication No. 31, and with the following:
1. Galvanized-Steel Sheet: ASTM A 653/A 653M, Structural Steel (SS), zinc coating.
 2. Deck Profile: As indicated.
 3. Profile Depth: As indicated.
 4. Design Uncoated-Steel Thickness: As indicated.
 5. Span Condition: As indicated.
 6. Side Laps: Overlapped or interlocking seam at Contractor's option.

2.3 COMPOSITE FLOOR DECK

- A. Manufacturers: Subject to compliance with requirements, available manufacturers offering products that may be incorporated into the Work include, but are not limited to the following:
1. Canam Steel Corporation; Canam Group, Inc.
 2. Nucor Corp.
- B. Composite Floor Deck: Fabricate panels, with integrally embossed or raised pattern ribs and interlocking side laps, to comply with "SDI Specifications and Commentary for Composite Steel Floor Deck," in SDI Publication No. 31, with the minimum section properties indicated, and with the following:
1. Galvanized-Steel Sheet: ASTM A 653/A 653M, Structural Steel (SS), Grade 33 (230), zinc coating.
 2. Profile Depth: As indicated.
 3. Design Uncoated-Steel Thickness: As indicated.
 4. Span Condition: As indicated.

2.4 ACCESSORIES

- A. General: Provide manufacturer's standard accessory materials for deck that comply with requirements indicated.
- B. Mechanical Fasteners: Corrosion-resistant, low-velocity, power-actuated or pneumatically driven carbon-steel fasteners; or self-drilling, self-threading screws.
- C. Side-Lap Fasteners: Corrosion-resistant, hexagonal washer head; self-drilling, carbon-steel screws, No. 10 (4.8-mm) minimum diameter.
- D. Flexible Closure Strips: Vulcanized, closed-cell, synthetic rubber.
- E. Miscellaneous Sheet Metal Deck Accessories: Steel sheet, minimum yield strength of 33,000 psi (230 MPa), not less than 0.0359-inch (0.91-mm) design uncoated thickness, of same material and finish as deck; of profile indicated or required for application.

- F. Pour Stops and Girder Fillers: Steel sheet, minimum yield strength of 33,000 psi (230 MPa), of same material and finish as deck, and of thickness and profile recommended by SDI Publication No. 31 for overhang and slab depth.
- G. Column Closures, End Closures, Z-Closures, and Cover Plates: Steel sheet, of same material, finish, and thickness as deck unless otherwise indicated.
- H. Recessed Sump Pans: Single-piece steel sheet, 0.0747 inch (1.90 mm) thick, of same material and finish as deck, with 3-inch- (76-mm-) wide flanges and sloped recessed pans of 1-1/2-inch (38-mm) minimum depth. For drains, cut holes in the field.
- I. Galvanizing Repair Paint: SSPC-Paint 20 or MIL-P-21035B, with dry film containing a minimum of 94 percent zinc dust by weight.

PART 3 - EXECUTION

3.1 EXAMINATION

- A. Examine supporting frame and field conditions for compliance with requirements for installation tolerances and other conditions affecting performance of the Work.
- B. Proceed with installation only after unsatisfactory conditions have been corrected.

3.2 INSTALLATION, GENERAL

- A. Install deck panels and accessories according to applicable specifications and commentary in SDI Publication No. 31, manufacturer's written instructions, and requirements in this Section.
- B. Install temporary shoring before placing deck panels if required to meet deflection limitations.
- C. Locate deck bundles to prevent overloading of supporting members.
- D. Place deck panels on supporting frame and adjust to final position with ends accurately aligned and bearing on supporting frame before being permanently fastened. Do not stretch or contract side-lap interlocks.
 - 1. Align cellular deck panels over full length of cell runs and align cells at ends of abutting panels.
- E. Place deck panels flat and square and fasten to supporting frame without warp or deflection.
- F. Cut and neatly fit deck panels and accessories around openings and other work projecting through or adjacent to deck.

- G. Provide additional reinforcement and closure pieces at openings as required for strength, continuity of deck, and support of other work.
- H. Comply with AWS requirements and procedures for manual shielded metal arc welding, appearance and quality of welds, and methods used for correcting welding work.
- I. Mechanical fasteners may be used in lieu of welding to fasten deck. Locate mechanical fasteners and install according to deck manufacturer's written instructions.

3.3 ROOF-DECK INSTALLATION

- A. Fasten roof-deck panels to steel supporting members by arc spot (puddle) welds of the surface diameter indicated or arc seam welds with an equal perimeter that is not less than 1-1/2 inches (38 mm) long, and as follows:
 - 1. Weld Diameter: As indicated.
 - 2. Weld Spacing: Weld edge and interior ribs of deck units with a minimum of two welds per deck unit at each support. Space welds as indicated.
- B. Side-Lap and Perimeter Edge Fastening: Fasten side laps and perimeter edges of panels between supports as indicated on drawing notes.
- C. End Bearing: Install deck ends over supporting frame with a minimum end bearing of 1-1/2 inches (38 mm), with end joints as follows:
 - 1. End Joints: Lapped 2 inches (51 mm) minimum or butted at Contractor's option.
- D. Roof Sump Pans and Sump Plates: Install over openings provided in roof deck and mechanically fasten flanges to top of deck. Space mechanical fasteners not more than 12 inches (305 mm) apart with at least one fastener at each corner.
 - 1. Install reinforcing channels or zees in ribs to span between supports and weld or mechanically fasten.
- E. Miscellaneous Roof-Deck Accessories: Install ridge and valley plates, finish strips, end closures, and reinforcing channels according to deck manufacturer's written instructions. mechanically fasten to substrate to provide a complete deck installation.
 - 1. Weld cover plates at changes in direction of roof-deck panels unless otherwise indicated.
- F. Flexible Closure Strips: Install flexible closure strips over partitions, walls, and where indicated. Install with adhesive according to manufacturer's written instructions to ensure complete closure.

3.4 FLOOR-DECK INSTALLATION

- A. Fasten floor-deck panels to steel supporting members by arc spot (puddle) welds of the surface diameter indicated and as follows:
 - 1. Weld Diameter: as indicated.
 - 2. Weld Spacing: Space and locate welds as indicated.
- B. Side-Lap and Perimeter Edge Fastening: Fasten side laps and perimeter edges of panels between supports, at intervals not exceeding the lesser of one-half of the span or 36 inches (914 mm), and as follows:
 - 1. Mechanically fasten with self-drilling, No. 10 (4.8-mm-) diameter or larger, carbon-steel screws.
- C. End Bearing: Install deck ends over supporting frame with a minimum end bearing of 1-1/2 inches (38 mm), with end joints as follows:
 - 1. End Joints: Butted.
- D. Pour Stops and Girder Fillers: Weld steel sheet pour stops and girder fillers to supporting structure according to SDI recommendations unless otherwise indicated.
- E. Floor-Deck Closures: Weld steel sheet column closures, cell closures, and Z-closures to deck, according to SDI recommendations, to provide tight-fitting closures at open ends of ribs and sides of deck.

3.5 FIELD QUALITY CONTROL

- A. Testing Agency: Owner will engage a qualified testing agency to perform tests and inspections.
- B. Field welds will be subject to inspection.
- C. Prepare test and inspection reports.

3.6 PROTECTION

- A. Galvanizing Repairs: Prepare and repair damaged galvanized coatings on both surfaces of deck with galvanized repair paint according to ASTM A 780/A 780M and manufacturer's written instructions.

END OF SECTION 053100

This page intentionally left blank

SECTION 054000 – COLD-FORMED METAL FRAMING

PART 1 - GENERAL

1.1 SUMMARY

A. This Section includes the following:

1. Exterior non-load bearing steel stud framing.
2. Interior non-load bearing steel stud framing

B. Related Sections include the following:

1. Division 05 Section "Metal Fabrications" for masonry shelf angles and connections and miscellaneous steel framing.

1.2 PERFORMANCE REQUIREMENTS

A. Structural Performance: Provide cold-formed metal framing capable of withstanding design loads within limits and under conditions indicated.

1. Design Loads: As indicated on Structural Drawings.
 - a. For interior non-load bearing studs, design loads shall include weight of cast stone wall panels and display case with original cast stone school sign panels.
2. Deflection Limits: Design framing systems to withstand design loads without deflections greater than the following:
 - a. Non-Load Bearing Studs: Horizontal deflection of 1/600 of the horizontally projected span.
3. Design framing systems to provide for movement of framing members without damage or overstressing, sheathing failure, connection failure, undue strain on fasteners and anchors, or other detrimental effects when subject to a maximum ambient temperature change of 120 deg F (67 deg C).

B. Cold-Formed Steel Framing, General: Design according to AISI's "Standard for Cold-Formed Steel Framing - General Provisions."

C. Cold-Formed Steel Framing Design Standards:

1. Wall Studs: AISI S211.
2. Headers: AISI S212.
3. Lateral Design: AISI S213.

D. AISI Specifications and Standards: Unless more stringent requirements are indicated, comply with AISI S100 and AISI S200.

1.3 SUBMITTALS

- A. Product Data: For each type of cold-formed metal framing product and accessory indicated.
- B. Shop Drawings: Show layout, spacings, sizes, thicknesses, and types of cold-formed metal framing; fabrication; and fastening and anchorage details, including mechanical fasteners. Show reinforcing channels, opening framing, supplemental framing, strapping, bracing, bridging, splices, accessories, connection details, and attachment to adjoining work.
 - 1. For cold-formed metal framing indicated to comply with design loads, include structural analysis data signed and sealed by the professional engineer licensed in the State of New York, who is responsible for their preparation.
- C. Welding certificates.
- D. Qualification Data: For professional engineer.
- E. Product Test Reports: From a qualified testing agency, unless otherwise stated, indicating that each of the following complies with requirements, based on evaluation of comprehensive tests for current products:
 - 1. Steel sheet.
 - 2. Expansion anchors.
 - 3. Power-actuated anchors.
 - 4. Mechanical fasteners.
 - 5. Vertical deflection clips.
 - 6. Horizontal drift deflection clips
 - 7. Miscellaneous structural clips and accessories.
- F. Research/Evaluation Reports: For cold-formed metal framing.

1.4 QUALITY ASSURANCE

- A. Engineering Responsibility: Preparation of Shop Drawings, design calculations, and other structural data by a qualified professional engineer.
- B. Professional Engineer Qualifications: A professional engineer who is licensed in the State of New York and who is experienced in providing engineering services of the kind indicated. Engineering services are defined as those performed for installations of cold-formed metal framing that are similar to those indicated for this Project in material, design, and extent.
- C. Product Tests: Mill certificates or data from a qualified independent testing agency indicating steel sheet complies with requirements, including base-metal thickness, yield strength, tensile strength, total elongation, chemical requirements, and metallic-coating thickness.

- D. Welding: Qualify procedures and personnel according to AWS D1.1/D1.1M, "Structural Welding Code--Steel," and AWS D1.3, "Structural Welding Code--Sheet Steel."
 - E. Fire-Test-Response Characteristics: Where indicated, provide cold-formed metal framing identical to that of assemblies tested for fire resistance per ASTM E 119 by a testing and inspecting agency acceptable to authorities having jurisdiction.
 - F. Vertical and Lateral Fire Propagation Test Characteristics: The exterior wall assembly of the School Building is required to comply with NFPA 285 "Standard Method of Test for the Evaluation of Flammability Characteristics of Exterior Nonload-bearing Wall Assemblies Containing Combustible Components." The base wall, stud cavity insulation, wall sheathing, air barrier, continuous wall rigid insulation and exterior cladding are components that are required to be to be evaluated as part of this specific assembly test. Cold-formed metal wall framing shall be part of an assembly that has passed NFPA 285 testing.
 - G. AISI Specifications and Standards: Comply with AISI's "North American Specification for the Design of Cold-Formed Steel Structural Members" and its "Standard for Cold-Formed Steel Framing - General Provisions."
 - 1. Comply with AISI's "Standard for Cold-Formed Steel Framing - Truss Design."
 - H. Preinstallation Conference: Conduct conference at Project site.
- 1.5 DELIVERY, STORAGE, AND HANDLING
- A. Protect cold-formed metal framing from corrosion, deformation, and other damage during delivery, storage, and handling.
 - B. Store cold-formed metal framing, protect with a waterproof covering, and ventilate to avoid condensation.

PART 2 - PRODUCTS

2.1 MANUFACTURERS

- A. Available Manufacturers: Subject to compliance with requirements, manufacturers offering cold-formed metal framing that may be incorporated into the Work include, but are not limited to, the following:
 - 1. ClarkDietrich Building Systems.
 - 2. MarinoWare; a division of Ware Industries.
 - 3. Super Stud Building Products, Inc.

2.2 MATERIALS

- A. Steel Sheet: ASTM A 1003/A 1003M, Structural Grade, Type H, metallic coated, of grade and coating weight as follows:

1. Grade: ST33H (ST230H) and ST50H (ST340H) as required by structural performance.
2. Coating: G60 (Z180).

2.3 EXTERIOR AND INTERIOR NON LOAD BEARING WALL FRAMING

- A. Built-up Members: Built-up members of manufacturer's standard C-shaped steel section, with stiffened flanges, nested into a U-shaped steel section joist track, with unstiffened flanges; unpunched; of web depths indicated; and as follows:
1. Minimum Base-Metal Thickness: 16 gauge minimum, unless otherwise indicated Drawings.
 2. Flange Width: 1-5/8 inches (41 mm), minimum.

2.4 FRAMING ACCESSORIES

- A. Fabricate steel-framing accessories from steel sheet, ASTM A 1003/A 1003M, Structural Grade, Type H, metallic coated, of same grade and coating weight used for framing members.
- B. Provide accessories of manufacturer's standard thickness and configuration, unless otherwise indicated, as follows:
1. Supplementary framing.
 2. Bracing, bridging, and solid blocking.
 3. Web stiffeners.
 4. Anchor clips.
 5. End clips.
 6. Gusset plates.
 7. Hole reinforcing plates.
 8. Backer plates.

2.5 ANCHORS, CLIPS, AND FASTENERS

- A. Steel Shapes and Clips: ASTM A 36/A 36M, zinc coated by hot-dip process according to ASTM A 123/A 123M.
- B. Anchor Bolts: ASTM F 1554, Grade 36, threaded carbon-steel hex-headed bolts headless, hooked bolts headless bolts, with encased end threaded, and carbon-steel nuts; and flat, hardened-steel washers; zinc coated by hot-dip process according to ASTM A 153/A 153M, Class C mechanically deposition according to ASTM B 695, Class 50.
- C. Expansion Anchors: Fabricated from corrosion-resistant materials, with capability to sustain, without failure, a load equal to 5 times design load, as determined by testing per ASTM E 488 conducted by a qualified independent testing agency.
- D. Power-Actuated Anchors: Fastener system of type suitable for application indicated, fabricated from corrosion-resistant materials, with capability to sustain, without failure,

a load equal to 10 times design load, as determined by testing per ASTM E 1190 conducted by a qualified independent testing agency.

- E. Mechanical Fasteners: ASTM C 1513, corrosion-resistant-coated, self-drilling, self-tapping steel drill screws.
 - 1. Head Type: Low-profile head beneath sheathing, manufacturer's standard elsewhere.
- F. Welding Electrodes: Comply with AWS standards.

2.6 MISCELLANEOUS MATERIALS

- A. Galvanizing Repair Paint: SSPC-Paint 20 or DOD-P-21035
- B. Cement Grout: Portland cement, ASTM C 150, Type I; and clean, natural sand, ASTM C 404. Mix at ratio of 1 part cement to 2-1/2 parts sand, by volume, with minimum water required for placement and hydration.
- C. Nonmetallic, Nonshrink Grout: Premixed, nonmetallic, noncorrosive, nonstaining grout containing selected silica sands, portland cement, shrinkage-compensating agents, and plasticizing and water-reducing agents, complying with ASTM C 1107, with fluid consistency and 30-minute working time.
- D. Shims: Load bearing, high-density multimonomer plastic, nonleaching.
- E. Sealer Gaskets: Closed-cell neoprene foam, 1/4 inch (6.4 mm) thick, selected from manufacturer's standard widths to match width of bottom track or rim track members.
- F. Spray Foam Insulation/Sealer: Low expansion type, recommended by manufacturer for intended use.

2.7 FABRICATION

- A. Fabricate cold-formed metal framing and accessories plumb, square, and true to line, and with connections securely fastened, according to referenced AISI's specifications and standards, manufacturer's written instructions, and requirements in this Section.
 - 1. Fabricate framing assemblies using jigs or templates.
 - 2. Cut framing members by sawing or shearing; do not torch cut.
 - 3. Fasten cold-formed metal framing members by welding, screw fastening, clinch fastening, or riveting as standard with fabricator. Wire tying of framing members is not permitted.
 - a. Comply with AWS D1.3 requirements and procedures for welding, appearance and quality of welds, and methods used in correcting welding work.
 - b. Locate mechanical fasteners and install according to Shop Drawings, with screw penetrating joined members by not less than three exposed screw threads.

4. Fasten other materials to cold-formed metal framing by welding, bolting, or screw fastening, according to Shop Drawings.
- B. Reinforce, stiffen, and brace framing assemblies to withstand handling, delivery, and erection stresses. Lift fabricated assemblies to prevent damage or permanent distortion.
- C. Fabrication Tolerances: Fabricate assemblies level, plumb, and true to line to a maximum allowable tolerance variation of 1/8 inch in 10 feet (1:960) and as follows:
 1. Spacing: Space individual framing members no more than plus or minus 1/8 inch (3 mm) from plan location. Cumulative error shall not exceed minimum fastening requirements of sheathing or other finishing materials.
 2. Squareness: Fabricate each cold-formed metal framing assembly to a maximum out-of-square tolerance of 1/8 inch (3 mm).

PART 3 - EXECUTION

3.1 EXAMINATION

- A. Examine supporting substrates and abutting structural framing for compliance with requirements for installation tolerances and other conditions affecting performance.
 1. Proceed with installation only after unsatisfactory conditions have been corrected.

3.2 PREPARATION

- A. Before sprayed fire-resistive materials are applied, attach continuous angles, supplementary framing, or tracks to structural members indicated to receive sprayed fire-resistive materials.
- B. After applying sprayed fire-resistive materials, remove only as much of these materials as needed to complete installation of cold-formed framing without reducing thickness of fire-resistive materials below that are required to obtain fire-resistance rating indicated. Protect remaining fire-resistive materials from damage.
- C. Install load bearing shims or grout between the underside of wall bottom track or rim track and the top of foundation wall or slab at stud or joist locations to ensure a uniform bearing surface on supporting concrete or masonry construction.

3.3 INSTALLATION, GENERAL

- A. Cold-formed metal framing may be shop or field fabricated for installation, or it may be field assembled.
- B. Install cold-formed metal framing according to AISI's "Standard for Cold-Formed Steel Framing - General Provisions" and to manufacturer's written instructions unless more stringent requirements are indicated.

- C. Install shop- or field-fabricated, cold-formed framing and securely anchor to supporting structure.
 - 1. Screw, bolt, or weld wall panels at horizontal and vertical junctures to produce flush, even, true-to-line joints with maximum variation in plane and true position between fabricated panels not exceeding 1/16 inch (1.6 mm).
 - D. Install cold-formed metal framing and accessories plumb, square, and true to line, and with connections securely fastened.
 - 1. Cut framing members by sawing or shearing; do not torch cut.
 - 2. Fasten cold-formed metal framing members by welding, screw fastening, clinch fastening, or riveting. Wire tying of framing members is not permitted.
 - a. Comply with AWS D1.3 requirements and procedures for welding, appearance and quality of welds, and methods used in correcting welding work.
 - b. Locate mechanical fasteners and install according to Shop Drawings, and complying with requirements for spacing, edge distances, and screw penetration.
 - E. Install framing members in one-piece lengths unless splice connections are indicated for track or tension members.
 - F. Install temporary bracing and supports to secure framing and support loads comparable in intensity to those for which structure was designed. Maintain braces and supports in place, undisturbed, until entire integrated supporting structure has been completed and permanent connections to framing are secured.
 - G. Do not bridge building expansion and control joints with cold-formed metal framing. Independently frame both sides of joints.
 - H. Fasten hole reinforcing plate over web penetrations that exceed size of manufacturer's standard punched openings.
 - I. Erection Tolerances: Install cold-formed metal framing level, plumb, and true to line to a maximum allowable tolerance variation of 1/8 inch in 10 feet (1:960) and as follows:
 - 1. Space individual framing members no more than plus or minus 1/8 inch (3 mm) from plan location. Cumulative error shall not exceed minimum fastening requirements of sheathing or other finishing materials.
- 3.4 EXTERIOR AND INTERIOR NON-LOAD-BEARING WALL INSTALLATION
- A. Install continuous tracks sized to match studs. Align tracks accurately and securely anchor to supporting structure as indicated.
 - B. Fasten both flanges of studs to top and bottom track, unless otherwise indicated. Space studs as follows:
 - 1. Stud Spacing: 16 inches (406 mm).

- C. Set studs plumb, except as needed for diagonal bracing or required for nonplumb walls or warped surfaces and similar requirements.
- D. Isolate non-load-bearing steel framing from building structure as required on Drawings to prevent transfer of vertical loads while providing lateral support.
 - 1. Install single-leg deflection tracks and anchor to building structure.
 - 2. Install double deep-leg deflection tracks and anchor outer track to building structure.
 - 3. Connect vertical deflection clips to studs and anchor to building structure.
 - 4. Connect drift clips to cold formed metal framing and anchor to building structure.
- E. Install horizontal bridging in wall studs, spaced in rows indicated on Shop Drawings but not more than 48 inches (1220 mm) apart. Fasten at each stud intersection.
 - 1. Install additional row of horizontal bridging in curtain wall stud beneath deflection track when curtain wall studs are not fastened to an additional top track.
 - 2. Bridging: Cold-rolled steel channel, welded or mechanically fastened to webs of punched studs.
- F. Install miscellaneous framing and connections, including stud kickers, web stiffeners, clip angles, continuous angles, anchors, fasteners, and stud girts, to provide a complete and stable wall-framing system

3.5 FIELD QUALITY CONTROL

- A. Testing: Owner will engage a qualified independent testing and inspecting agency to perform field tests and inspections and prepare test reports.
- B. Field and shop welds and screw connections will be subject to testing and inspecting.
- C. Testing agency will report test results within 24 hours and in writing to Contractor and Architect.
- D. Remove and replace work where test results indicate that it does not comply with specified requirements.
- E. Additional testing and inspecting, at Contractor's expense, will be performed to determine compliance of replaced or additional work with specified requirements.
- F. Inspect all prefabricated trusses before installation.

3.6 REPAIRS AND PROTECTION

- A. Galvanizing Repairs: Prepare and repair damaged galvanized coatings on fabricated and installed cold-formed metal framing with galvanized repair paint according to ASTM A 780 and manufacturer's written instructions.

- B. Provide final protection and maintain conditions, in a manner acceptable to manufacturer and Installer, that ensure that cold-formed metal framing is without damage or deterioration at time of Substantial Completion.

END OF SECTION 054000

SECTION 055000 - METAL FABRICATIONS

PART 1 - GENERAL

1.1 SUMMARY

A. This Section includes the following:

1. Steel ladder.
2. Steel ladder with cage.
3. Aluminum roof ladder with parapet crossover platform.
4. Steel stairs with concrete-filled treads and platforms.
5. Steel stairs with metal grating treads and platforms.
6. Handrails and railings at stairs and ramps.
7. Handrails attached to walls adjacent to stairs and ramps.
8. Guardrails, including guardrails at exterior locations.
9. Support angles for elevator door sills.
10. Loose bearing and leveling plates.
11. Loose steel lintels.
12. Shelf angles.
13. Steel framing and supports for ceiling hung doors and panels, ceiling hung equipment, ceiling hung curtains, ceiling hung partitions, and other items indicated on Drawings.
14. Steel framing and supports for mechanical and electrical equipment.
15. Steel framing and supports for part height partitions.
16. Steel framing and supports for applications where framing and supports are not specified in other Sections.
17. Steel elevator sump pit gratings.
18. Areaway gratings.
19. Aluminum pencil-proof bar gratings.
20. Cast metal nosings at concrete stairs.
21. Elevator hoistway beam.
22. Vertical mesh sunshades.
23. Bollards

1.2 PERFORMANCE REQUIREMENTS

- A. Delegated Design: Engage a qualified professional engineer, as defined in Section 014000 "Quality Requirements," to design metal stairs, handrails and railings, guardrails, ladders and sunshade attachments.
- B. Structural Performance of Ladders: Ladders shall withstand the effects of loads and stresses within limits and under conditions specified in ANSI A14.3.
- C. Structural Performance of Metal Stairs, Walkways and Platforms: Provide metal stairs, walkways and platforms capable of withstanding the following structural loads without exceeding the allowable design working stress of the materials involved, including anchors

and connections. Apply each load to produce the maximum stress in each component of metal stairs, walkways and platforms.

1. Treads and Platforms of Metal Stairs, and Walkways: Capable of withstanding a uniform load of 100 lbf/sq. ft. (4.79 kN/sq. m) or a concentrated load of 300 lbf (1.33 kN) on an area of 4 sq. in. (25.8 sq. cm), whichever produces the greater stress.
2. Stair and Walkway Framing: Capable of withstanding stresses resulting from loads specified above in addition to stresses resulting from railing system loads.
3. Limit deflection of treads, platforms, walkways and framing members to $L/360$ or 1/4 inch (6.4 mm), whichever is less.

D. Structural Performance of Handrails and Railings: Provide handrails and railings capable of withstanding the following structural loads without exceeding the allowable design working stress of materials for handrails, railings, anchors, and connections:

1. Top Rail of Guards: Capable of withstanding the following loads applied as indicated:
 - a. Concentrated load of 200 lbf (890 N) applied at any point and in any direction.
 - b. Uniform load of 50 lbf/ft. (730 N/m) applied horizontally and concurrently with uniform load of 100 lbf/ft. (1460 N/m) applied vertically downward.
 - c. Concentrated and uniform loads above need not be assumed to act concurrently.
2. Handrails Not Serving as Top Rails: Capable of withstanding the following loads applied as indicated:
 - a. Concentrated load of 200 lbf (890 N) applied at any point and in any direction.
 - b. Uniform load of 50 lbf/ft. (730 N/m) applied in any direction.
 - c. Concentrated and uniform loads above need not be assumed to act concurrently.
3. Infill Area of Guards: Capable of withstanding a horizontal concentrated load of 200 lbf (890 N) applied to 1 sq. ft. (0.09 sq. m) at any point in system, including panels, intermediate rails, balusters, or other elements composing infill area.
 - a. Load above need not be assumed to act concurrently with loads on top rails in determining stress on guards.

E. Structural Performance of Mesh Sunscreens: Installed mesh sunscreens shall withstand the effects of loads and stresses at their connection points to the structure as follows:

1. Wind Loads: As indicated on Structural Drawings.
2. Other Design Loads: As indicated on Structural Drawings

1.3 ACTION SUBMITTALS

A. Product Data: For all fabricated products including the following:

1. Gratings.
2. Paint products.
3. Grout.

4. Nonslip aggregates and nonslip-aggregate surface finishes
5. Ladders
6. Nosings.
7. Mesh infill for railings.
8. Mesh sunscreens.
9. Pre-engineered handrail and railing systems.
10. Metal grating stair systems.

B. Shop Drawings: Detail fabrication and erection of each metal fabrication indicated. Include plans, elevations, sections, and details of metal fabrications and their connections. Show anchorage and accessory items.

1. For installed products indicated to comply with design loads, include structural analysis data signed and sealed by the qualified professional engineer responsible for their preparation.

C. Samples for Verification: Sample of the following:

1. 6" square piece of each type of bar grating.
2. Each type of stainless steel finish on 6" long piece of each type of metal shape.
3. 6" long fabricated stainless steel handrail
4. 12" square piece of mesh railing infill.
5. 6" square piece of mesh sunscreen material.
6. 6" square piece of bar grating used for platforms and stairs.

1.4 INFORMATIONAL SUBMITTALS

- A. Welding Certificates: Copies of certificates for welding procedures and personnel.
- B. Qualification Data: For firms and persons specified in "Quality Assurance" Article to demonstrate their capabilities and experience. Include lists of completed projects with project names and addresses, names and addresses of architects and owners, and other information specified.
- C. Delegated-Design Submittal: For stairs, handrails and railings, guardrails, ladders, and mesh sunscreens, including analysis data signed and sealed by the qualified professional engineer responsible for their preparation.

1.5 QUALITY ASSURANCE

- A. Fabricator Qualifications: A firm experienced in producing metal fabrications similar to those indicated for this Project and with a record of successful in-service performance, as well as sufficient production capacity to produce required units.
- B. Professional Engineer Qualifications: A professional engineer who is legally qualified to practice in jurisdiction where Project is located and who is experienced in providing engineering services of the kind indicated. Engineering services are defined as those performed for installations of metal stairs, platforms, walkways, handrails and railing

systems, ladders and mesh sunscreens that are similar to those indicated for this Project in material, design, and extent.

C. Welding: Qualify procedures and personnel according to the following:

1. AWS D1.1, "Structural Welding Code--Steel."
2. AWS D1.3, "Structural Welding Code--Sheet Steel."
3. AWS D1.2, "Structural Welding Code--Aluminum."
4. AWS D1.6, "Structural Welding Code--Stainless Steel."
5. Certify that each welder has satisfactorily passed AWS qualification tests for welding processes involved and, if pertinent, has undergone recertification.

D. Mockups, Railings and Handrails: Build mockups of each type of handrail, railing and guardrail system to verify selections made under sample submittals and to demonstrate aesthetic effects and set quality standards for fabrication and installation.

1. Each mock-up shall consist of a typical panel including two posts, top rail, infill area, and anchorage system components that are full height and are not less than 24 inches (600 mm) in length.
 - a. For railing system with metal mesh guard infill, provide two mockups, one in each color as selected by Architect.
2. Notify Architect seven days in advance of dates and times when mock-up will be constructed
3. Remove/dismantle and reprepare mock-up as required to obtain Architect's approval.
4. Approved mock-ups may be incorporated in the finished work.

E. Mockups, Mesh Sunscreens: Build mockups of typical mesh sunscreen system to verify selections made under sample submittals and to demonstrate aesthetic effects and set quality standards for fabrication and installation.

1. Each mock-up shall consist of a typical mesh sunscreen panel including top and bottom attachment tubes and their connections to the structure.
2. Locate on the building where directed by the Architect.
3. Notify Architect seven days in advance of dates and times when mock-up will be constructed
4. Remove/dismantle and reprepare mock-up as required to obtain Architect's approval.
5. Approved mock-ups may be incorporated in the finished work.

1.6 PROJECT CONDITIONS

- A. Field Measurements: Where metal fabrications are indicated to fit walls and other construction, verify dimensions by field measurements before fabrication and indicate measurements on Shop Drawings. Coordinate fabrication schedule with construction progress to avoid delaying the Work.

1. Established Dimensions: Where field measurements cannot be made without delaying the Work, establish dimensions and proceed with fabricating metal fabrications without field measurements. Coordinate construction to ensure that actual dimensions correspond to established dimensions. Allow for trimming and fitting.

1.7 COORDINATION

- A. Coordinate installation of anchorages for metal fabrications. Furnish setting drawings, templates, and directions for installing anchorages, including sleeves, concrete inserts, anchor bolts, and items with integral anchors, that are to be embedded in concrete or masonry. Deliver such items to Project site in time for installation.

1.8 SEQUENCING AND SCHEDULING

- A. Sequence and coordinate installation of wall handrails as follows:
 1. Mount handrails only on completed walls. Do not support handrails temporarily by any means not satisfying structural performance requirements.
 2. Mount handrails only on gypsum board assemblies reinforced to receive anchors, and where the location of concealed anchor plates has been clearly marked for benefit of Installer.

PART 2 - PRODUCTS

2.1 METALS, GENERAL

- A. Metal Surfaces, General: For metal fabrications exposed to view in the completed Work, provide materials with smooth, flat surfaces without blemishes. Do not use materials with exposed pitting, seam marks, roller marks, rolled trade names, or roughness.

2.2 FERROUS METALS

- A. Steel Plates, Shapes, and Bars: ASTM A 36/A 36M.
- B. Steel Tubing: Cold-formed steel tubing complying with ASTM A 500. For exterior installations and where indicated, provide tubing with hot-dip galvanized coating.
- C. Steel Pipe: ASTM A 53, standard weight (Schedule 40), unless another weight is indicated or required by structural loads. For exterior installations and where indicated, provide pipe with hot-dip galvanized coating.
- D. Slotted Channel Framing: Cold-formed metal channels with flange edges returned toward web and with 9/16-inch- (14.3-mm-) wide slotted holes in webs at 2 inches (51 mm) o.c.
 1. Width of Channels: 1-5/8 inches (41 mm).
 2. Depth of Channels: As indicated.

3. Metal and Thickness: Galvanized steel complying with ASTM A 653/A 653M, structural quality, Grade 33 (Grade 230), with G90 (Z275) coating; 0.108-inch (2.8-mm) nominal thickness.
 4. Finish: Unfinished.
- E. Steel Bars for Gratings: ASTM A 36/A 36M.
- F. Wire Rod for Grating Crossbars: (ASTM A 510M)
- G. Malleable-Iron Castings: ASTM A 47, Grade 32510 (ASTM A 47M, Grade 22010).
- H. Gray-Iron Castings: ASTM A 48, Class 30 (ASTM A 48M, Class 200), unless another class is indicated or required by structural loads.
- I. Cast-in-Place Anchors in Concrete: Anchors of type indicated below, fabricated from corrosion-resistant materials capable of sustaining, without failure, the load imposed within a safety factor of 4, as determined by testing per ASTM E 488, conducted by a qualified independent testing agency.
1. Threaded or wedge type; galvanized ferrous castings, either ASTM A 47 (ASTM A 47M) malleable iron or ASTM A 27/A 27M cast steel. Provide bolts, washers, and shims as needed, hot-dip galvanized per ASTM A 153/A 153M.
- J. Welding Rods and Bare Electrodes: Select according to AWS specifications for metal alloy welded.

2.3 STAINLESS STEEL

- A. Tubing: ASTM A 554, Grade MT 304
- B. Pipe: ASTM A 312/A 312M, Grade TP 304
- C. Castings: ASTM A 743/A 743M, Grade CF 8 or CF 20.
- D. Plate and Sheet: ASTM A 666, Type 304

2.4 ALUMINUM

- A. Extruded Bars, Shapes and Mouldings: ASTM B 221 (ASTM B 221M), alloy 6063-T6 or 6063-T52.
- B. Castings: ASTM B 26, Almag 35.

2.5 PAINT

- A. Shop Primer for Interior Ferrous Metal: Modified oil-alkyd primer, Tnemec 88-559 or 10-1009, or equivalent. Primer shall be compatible with finish paint specified in Section 09900.

- B. Shop Primer for Galvanized Ferrous Metal: Polyamide epoxy primer, Tnemec F.C. Typoxy Series 27, or equivalent. Primer shall be compatible with finish paint specified in Section 09900.
- C. Galvanizing Repair Paint: High-zinc-dust-content paint for regalvanizing welds in steel, complying with SSPC-Paint 20.
- D. Shop Primer for Exterior Ferrous Metal: Organic zinc-rich primer, complying with SSPC-Paint 20 and compatible with topcoat; Tneme-Zinc 90-97; Tnemec Company, Inc.
- E. Bituminous Paint: Cold-applied asphalt mastic complying with SSPC-Paint 12, except containing no asbestos fibers, or cold-applied asphalt emulsion complying with ASTM D 1187.

2.6 FASTENERS

- A. General: Provide Type 304 or 316 stainless-steel fasteners for exterior use and zinc-plated fasteners with coating complying with ASTM B 633, Class Fe/Zn 5, where built into exterior walls, except as noted below. Select fasteners for type, grade, and class required.
- B. Bolts and Nuts: Regular hexagon-head bolts, ASTM A 307, Grade A (ASTM F 568M, Property Class 4.6); with hex nuts, ASTM A 563 (ASTM A 563M); and, where indicated, flat washers.
- C. Anchor Bolts: ASTM F 1554, Grade 36.
- D. Machine Screws: ASME B18.6.3 (ASME B18.6.7M).
- E. Lag Bolts: ASME B18.2.1 (ASME B18.2.3.8M).
- F. Wood Screws: Flat head, carbon steel, ASME B18.6.1.
- G. Plain Washers: Round, carbon steel, ASME B18.22.1 (ASME B18.22M).
- H. Lock Washers: Helical, spring type, carbon steel, ASME B18.21.1 (ASME B18.21.2M).
- I. Expansion Anchors: Anchor bolt and sleeve assembly of material indicated below with capability to sustain, without failure, a load equal to six times the load imposed when installed in unit masonry and equal to four times the load imposed when installed in concrete, as determined by testing per ASTM E 488, conducted by a qualified independent testing agency.
 - 1. Material: Carbon-steel components zinc-plated to comply with ASTM B 633, Class Fe/Zn 5.
- J. Toggle Bolts: FS FF-B-588, tumble-wing type, class and style as needed.

2.7 GROUT

- A. Nonshrink, Nonmetallic Grout: Factory-packaged, nonstaining, noncorrosive, nongaseous grout complying with ASTM C 1107. Provide grout specifically recommended by manufacturer for interior and exterior applications.

2.8 CONCRETE FILL

- A. Concrete Materials and Properties: Normal-weight, ready-mixed concrete with a minimum 28-day compressive strength of 3000 psi (20 MPa), unless higher strengths are indicated.

2.9 FABRICATION, GENERAL

- A. Shop Assembly: Preassemble items in shop to greatest extent possible to minimize field splicing and assembly. Disassemble units only as necessary for shipping and handling limitations. Use connections that maintain structural value of joined pieces. Clearly mark units for reassembly and coordinated installation.
- B. Shear and punch metals cleanly and accurately. Remove burrs.
- C. Ease exposed edges to a radius of approximately 1/32 inch (1 mm), unless otherwise indicated. Form bent-metal corners to smallest radius possible without causing grain separation or otherwise impairing work.
- D. Weld corners and seams continuously to comply with the following:
 - 1. Use materials and methods that minimize distortion and develop strength and corrosion resistance of base metals.
 - 2. Obtain fusion without undercut or overlap.
 - 3. Remove welding flux immediately.
 - 4. At exposed connections, finish exposed welds and surfaces smooth and blended so no roughness shows after finishing and contour of welded surface matches that of adjacent surface.
- E. Provide for anchorage of type indicated; coordinate with supporting structure. Fabricate and space anchoring devices to secure metal fabrications rigidly in place and to support indicated loads.
- F. Cut, reinforce, drill, and tap metal fabrications as indicated to receive finish hardware, screws, and similar items.
- G. Fabricate joints that will be exposed to weather in a manner to exclude water, or provide weep holes where water may accumulate.
- H. Allow for thermal movement resulting from the following maximum change (range) in ambient and surface temperatures by preventing buckling, opening up of joints, overstressing of components, failure of connections, and other detrimental effects. Base engineering calculation on surface temperatures of materials due to both solar heat gain and nighttime-sky heat loss.

1. Temperature Change (Range): 120 deg F (67 deg C), ambient; 180 deg F (100 deg C), material surfaces.

- I. Form exposed work true to line and level with accurate angles and surfaces and straight sharp edges.
- J. Remove sharp or rough areas on exposed traffic surfaces.
- K. Form exposed connections with hairline joints, flush and smooth, using concealed fasteners where possible. Use exposed fasteners of type indicated or, if not indicated, Phillips flat-head (countersunk) screws or bolts. Locate joints where least conspicuous.

2.10 ROUGH HARDWARE

- A. Furnish bent or otherwise custom fabricated bolts, plates, anchors, hangers, dowels, and other miscellaneous steel and iron shapes as required for framing and supporting woodwork, and for anchoring or securing woodwork to concrete or other structures. Straight bolts and other stock rough hardware items are specified in Division 6 sections.
- B. Fabricate items to sizes, shapes, and dimensions required. Furnish malleable-iron washers for heads and nuts which bear on wood structural connections; elsewhere, furnish steel washers.

2.11 METAL STAIRS

- A. General: Construct stairs to conform to sizes and arrangements indicated. Join pieces together by welding, unless otherwise indicated. Provide complete stair and bleacher assemblies, including metal framing, hangers, struts, clips, brackets, bearing plates, and other components necessary for the support of stairs, and platforms, and as required to anchor, hang, and contain the stairs on the supporting structure.
- B. NAAMM Stair Standard: Comply with "Recommended Voluntary Minimum Standards for Fixed Metal Stairs" in NAAMM AMP 510, "Metal Stairs Manual," for class of stair designated, unless more stringent requirements are indicated.
 - 1. Commercial class.
- C. Stair Framing: Fabricate stringers of structural steel channels, or plates, or a combination thereof, as indicated. Provide closures for exposed ends of stringers. Construct platforms of structural steel channel headers and miscellaneous framing members as indicated. Weld headers to strings, and framing members to strings and headers.
 - 1. Where required, provide hanger rods to support landings from floor construction above. Locate hanger rods within stud space of shaft-wall construction.
 - 2. Where masonry walls support metal stairs, provide temporary supporting struts designed for erecting steel stair components before installing masonry.

- D. Metal Risers, Subtread Pans, and Subplatforms: Form to configurations shown from steel sheet of thickness necessary to support indicated loads, but not less than 0.0677 inch (1.7 mm).
1. Steel Sheet: Uncoated cold-rolled steel sheet, unless otherwise indicated.
 2. Attach risers and subtreads to stringers with brackets made of steel angles or bars. Weld brackets to stringers and attach metal pans to brackets by welding, riveting, or bolting.
 3. Shape metal pans to include nosing integral with riser.
- E. Metal Grating Risers, Treads and Platforms: Form to configurations shown for steel framed structure and risers, and steel grating treads and platforms.
1. Fabricate grating treads with anti-slip nosing and with angle or plate carrier at each end for stringer connections. Secure treads to stringers by welding unless otherwise indicated.
 2. Fabricate grating platforms with anti-slip nosings. Provide toeplates at open-sided edges of grating platforms. Attach grating to platform framing by welding.
 3. Fabricate platforms and treads from press-locked steel grating with 1-1/4-by-3/16-inch (32-by-5-mm) bearing bars at 7/16 inch (13 mm) o.c. and 1/4 inch (7.5 mm) crossbars at 4 inches (100 mm) o.c., NAAMM designation: P-7-4 (1-1/4 x 3/16) STEEL.
 4. Gratings spacing shall be ADA compliant.
 5. Surface: Smooth
 6. Surface Coating: Metal bonded anti-slip coating, either by the plasma stream deposition process of steel on steel (SlipNOT), or metal spray arc bonding abrasive grit particles to surface (Mebac). Level of coating shall be #3 for Mebac, and Grade 2 for SlipNOT.
 7. Basis of Design Product: SlipNOT Bar Grating 7-4 manufactured by SlipNOT Metal Safety Flooring, or equal by one of the following:
 - a. Harsco Industrial IKG; CMI series, "Mebac" coating.
 - b. Brown-Campbell Co.; 7P4 series, "Mebac" coating
- F. Steel Stair Finishes:
1. Provide hot-dipped galvanized finish for all components of exterior stair and platform system including fittings, brackets, anchors, fasteners, and sleeves
 2. Shop prime and field paint all steel stairs systems

2.12 HANDRAILS AND RAILINGS AND GUARDRAILS

- A. General: Fabricate handrails and railings to comply with requirements indicated for design, dimensions, details, finish, and member sizes, including wall thickness of tube, post spacings, and anchorage, but not less than that needed to withstand indicated loads.
1. For post-mounted handrails at ramps in corridors where indicated, provide pre-engineered round post stainless steel railing system consisting of the following:

- a. Stainless steel Type 304 tubular handrails and posts with 1-1/2" outside diameter by 5/64" wall thickness for handrails and 1.9" diameter by 0.109" wall thickness for posts.
 - b. Finish shall be 240 grain/grit finish.
 - c. Provide top caps for posts, fasteners and all other accessories as required for complete installation.
 - d. Basis of Design Product: Provide CIRCUM Round Post Railing System by HDI Railing Systems, or equal.
- B. Interconnect members by butt-welding or welding with internal connectors, at fabricator's option, unless otherwise indicated.
1. At tee and cross intersections of pipe and tube, cope ends of intersecting members to fit contour of tube to which end is joined, and weld all around.
- C. Form changes in direction of handrails and rails as detailed.
- D. Form simple and compound curves by bending members in jigs to produce uniform curvature for each repetitive configuration required; maintain cross section of member throughout entire bend without buckling, twisting, cracking, or otherwise deforming exposed surfaces of components.
- E. Close exposed ends of pipe and tube handrail and railing members with prefabricated end fittings.
- F. Provide wall returns at ends of wall-mounted handrails, unless otherwise indicated. Close ends of returns, unless clearance between end of rail and wall is 1/4 inch (6 mm) or less.
- G. Mesh Panels for Railing Infill Panels: Provide prefabricated mesh panels fabricated from electro-forge welded galvanized steel main bars 1" x 5/64" and round cross bars 3/16" diameter with mesh opening/spacing dimensions of 1-21/32" x 5-3/16", and as follows:
1. Overall Mesh Panel Size: As indicated on Drawings
 2. Finish: Powder coated (factory applied) in color "Silver".
 3. Basis of Design Product: Grotto Design by Ametco Manufacturing Corp., or equal.
- H. Provide swinging gates to match railing/guard construction, complete with self-closing spring hinges and lockset where indicated.
- I. Brackets, Flanges, Fittings, and Anchors: Provide wall brackets, end closures, flanges, miscellaneous fittings, and anchors for interconnecting railings and for attaching to other work. Furnish inserts and other anchorage devices for connecting to concrete or masonry work.
1. Connect railing posts to metal framing by direct welding, unless otherwise indicated.
 2. Connect railing posts to concrete by inserting into preset sleeves, attaching to floor brackets, or core drilling, as indicated.

- J. Fillers: Provide fillers made from steel plate, or other suitably crush-resistant material, where needed to transfer wall bracket loads through wall finishes to structural supports. Size fillers to suit wall finish thicknesses and to produce adequate bearing area to prevent bracket rotation and overstressing of substrate.
- K. Provide inserts and other anchorage devices for connecting railings to concrete or masonry work. Fabricate anchorage devices capable of withstanding loads imposed by railings. Coordinate anchorage devices with supporting structure.
- L. For railing posts set in concrete, provide steel sleeves not less than 6 inches (150 mm) long with inside dimensions not less than 1/2 inch (13 mm) greater than outside dimensions of post, with steel plate forming bottom closure.
- M. For galvanized handrails and railings, provide galvanized fittings, brackets, fasteners, sleeves, and other ferrous-metal components.
- N. For nongalvanized handrails and railings, provide nongalvanized ferrous-metal fittings, brackets, fasteners, and sleeves, except galvanize anchors embedded in exterior masonry and concrete construction.
- O. Steel Handrail and Railing Finishes:
 - 1. Provide non-galvanized finish for steel components of interior steel railings and handrails. Provide nongalvanized ferrous metal fittings, brackets, fasteners, and sleeves, except galvanize anchors embedded in masonry and concrete construction.
 - 2. Provide hot-dipped galvanized finish for all components of exterior steel handrail and railing system including fittings, brackets, anchors, fasteners, and sleeves.
 - 3. Shop prime and field paint all steel handrails and railings.
 - 4. Provide painted finish for "loop" steel handrails at sitting stairs in cafeteria.
- P. Stainless Steel Handrail Finishes: No. 4.

2.13 STEEL LADDERS

- A. General: Fabricate ladders for locations shown, with dimensions, spacings, details, and anchorages as indicated.
 - 1. Comply with ANSI A14.3, except for elevator pit ladders.
 - 2. For elevator pit ladders, comply with ASME A17.1/CSA B44.
- B. Siderails: Continuous, 1/2-by-2-1/2-inch (12-by-64-mm) steel flat bars, with eased edges, spaced 18 inches (457 mm) apart.
- C. Bar Rungs: 3/4-inch- (19-mm-) diameter steel bars, spaced 12 inches (300 mm) o.c.
- D. Fit rungs in centerline of side rails; plug-weld and grind smooth on outer rail faces.

- E. Support each ladder at top and bottom and not more than 60 inches (1500 mm) o.c. with welded or bolted steel brackets. Size brackets to support design loads specified in ANSI A14.3.
- F. Provide nonslip surfaces on top of each rung, either by coating rung with aluminum-oxide granules set in epoxy-resin adhesive or by using a type of manufactured rung filled with aluminum-oxide grout.
- G. Galvanize ladders, including brackets and fasteners, in the following locations:
 - 1. Exterior.
 - 2. Interior, where indicated.

2.14 STEEL LADDERS WITH SAFETY CAGES

- A. Basis of Design Product: Cotterman Series MSC Modular Fixed Steel Ladders or equal.
- B. Fabrication:
 - 1. Side Members: 1/4" x 2" x 2" steel angle.
 - 2. Climbing Rungs: 3/4" corrugated steel round rungs spaced 12" o.c.
 - 3. Stand Off Brackets: 7"
 - 4. Modular Assemblies: Fabricate in sub-assemblies with no section greater than 7' in length.
 - 5. Safety Cages: Fabricate with flared bottom opening, beginning 7' from bottom of ladder.
- C. Load Capacity: 300 lbs.
- D. Finish: Powder coat paint in color selected by Architect.

2.15 ALUMINUM LADDERS WITH CROSSOVER PLATFORMS

- A. General: Fabricate ladders with crossover platforms to comply with ANSI A14.3 and OSHA Standard 3124-12r 2003 "Stairways and Ladders". Assemble by welding or riveting.
- B. Tubular Rail Low Parapet Access Ladder with Platform and Return: Provide ladder with crossover platform fabricated with the following components:
 - 1. Rungs: Not less than 1-1/4 inches (32 mm) in section and 18-3/8 inches (467mm) long, formed from tubular aluminum extrusions. Squared and deeply serrated on all sides. Rungs shall withstand a 1,500 pound (454 kg) load without deformation or failure.
 - 2. Heavy Duty Tubular Side Rails: Assembled from two interlocking aluminum extrusions no less than 1/8 inch (3 mm) wall thickness by 3 inches (76 mm) wide. Construction shall be self-locking stainless steel fasteners, full penetration TIG welds and clean, smooth and burrfree surfaces.

3. Walk-Through Rail and Roof Rail Extension: Not less than 3 feet 6 inches (1067 mm) above the landing and shall be fitted with deeply serrated, square, tubular grab rails.
4. Landing Platform: 1-1/2 inches (38 mm) or greater diameter, tubular aluminum guardrails and decks of serrated aluminum treads.
5. Ladder Size: As indicated on Drawings for each location.
6. Finish: Mill finish.
7. Basis of Design Product: Model 503 by O'Keeffe's Inc. or equal products of one of the following:
 - a. UPNOVR Inc.
 - b. Precision Ladders, LLC

C. Provide all fasteners and attachment brackets to building as required.

2.16 METAL GRATINGS

A. Metal Bar Gratings: Form to configurations shown from metal bar grating; fabricate to comply with NAAMM MBG 531, "Metal Bar Grating Manual"

1. Steel Gratings: Fabricate from welded steel grating with 1-1/4-by-3/16-inch (32-by-5-mm) bearing bars at 15/16 inch (24 mm) o.c. and crossbars at 4 inches (100 mm) o.c., NAAMM designation: W-15-4 (1-1/4 x 3/16) STEEL. Surface shall be smooth.
 - a. Application: Elevator pit sump pit cover.
2. Steel Gratings: Fabricate from press-locked steel grating with 1-1/4-by-3/16-inch (32-by-5-mm) bearing bars at 7/16 inch (13 mm) o.c. and 1/4 inch (7.5 mm) crossbars at 4 inches (100 mm) o.c., NAAMM designation: P-7-4 (1-1/4 x 3/16) STEEL. Surface shall be smooth.
 - a. Gratings spacing shall be ANSI A117.1-2003 compliant.
 - b. Surface Coating: Metal bonded anti-slip coating, either by the plasma stream deposition process of steel on steel (SlipNOT), or metal spray arc bonding abrasive grit particles to surface (Mebac). Level of coating shall be #3 for Mebac, and Grade 2 for SlipNOT.
 - c. Basis of Design Product: SlipNOT Bar Grating 7-4 manufactured by SlipNOT Metal Safety Flooring, or equal by one of the following:
 - 1) Harsco Industrial IKG; CMI series, "Mebac" coating.
 - 2) Brown-Campbell Co.; 7P4 series, "Mebac" coating
 - d. Application: Areaway gratings.
3. Aluminum Pencil Proof Linear Bar Grille/Diffuser: Extruded aluminum 7/32" fixed bars at 7/16" spacing, zero degree deflection. Bars shall be fixed and parallel in the long direction. Provide in 6 ft lengths. Provide end borders and mitered corners as required to close off ends.
 - a. Basis of Design Product: Model CT-PP-0 by Titus or equal.
 - b. Toe Kick Grille: Provide combination Type C1 and C5 frame and border with loose angles and cam nuts, no base flange.
 - c. Top Surface Grille: Provide Type 2 frame and border (3/4" border).
 - d. Finish: Black powder coat.

- e. Application: Unit cabinet heaters.
 - B. Steel Frames: Fabricate from ASTM A 36/A 36M steel angle, 1-1/2" x 1-1/2" x 1/4" in size unless otherwise noted, with welded anchor for casting into slab.
 - C. Fabricate grating with steel angle or steel plate carrier at each end for attachment to frame. Secure grating to frame with removable bolts; provide tamper proof bolts for exterior locations.
 - D. Do not notch bearing bars at supports to maintain elevation
 - E. Steel Grating Finishes:
 - 1. Provide hot-dipped galvanized finish for all components of elevator pit gratings and areaway gratings including fittings, brackets, anchors, fasteners, and sleeves.
 - 2. Provide hot-dipped galvanized finish for all steel frames for gratings.
 - 3. Shop prime and field paint all steel gratings and steel framing members.
 - F. Aluminum Grating Finishes: As specified for each application.
- 2.17 LOOSE BEARING AND LEVELING PLATES
- A. Provide loose bearing and leveling plates for steel items bearing on masonry or concrete construction. Drill plates to receive anchor bolts and for grouting.
 - B. Galvanize plates after fabrication.
- 2.18 LOOSE STEEL LINTELS
- A. Fabricate loose structural-steel lintels from steel angles and shapes of size indicated for openings and recesses in masonry walls and partitions at locations indicated.
 - B. Weld adjoining members together to form a single unit where indicated.
 - C. Size loose lintels to provide bearing length at each side of openings equal to one-twelfth of clear span, but not less than 8 inches (200 mm), unless otherwise indicated.
 - D. Galvanize loose steel lintels located in exterior walls.
 - E. Shop prime and field paint all lintels, leave embedded portions of lintels unpainted.
- 2.19 SHELF ANGLES
- A. Fabricate shelf angles from steel angles of sizes indicated and for attachment to concrete framing. Provide horizontally slotted holes to receive 3/4-inch (19-mm) bolts, spaced not more than 6 inches (150 mm) from ends and 24 inches (600 mm) o.c., unless otherwise indicated.
 - B. Galvanize shelf angles to be installed in exterior walls.

- C. Furnish wedge-type concrete inserts, complete with fasteners, to attach shelf angles to cast-in-place concrete.

2.20 MISCELLANEOUS FRAMING AND SUPPORTS

- A. General: Provide steel framing and supports that are not a part of structural-steel framework as necessary to complete the Work.
- B. Fabricate units from structural-steel shapes, plates, tubes, and bars of welded construction, unless otherwise indicated. Fabricate to sizes, shapes, and profiles indicated and as necessary to receive adjacent construction retained by framing and supports. Cut, drill, and tap units to receive hardware, hangers, and similar items.
 - 1. Fabricate units from slotted channel framing where indicated.
 - 2. Where units are indicated to be cast into concrete or built into masonry, equip with integrally welded steel strap anchors 1-1/4 inches (32 mm) wide by 1/4 inch (6 mm) thick by 8 inches (200 mm) long at 24 inches (600 mm) o.c., unless otherwise indicated.
 - 3. Furnish inserts if units must be installed after concrete is placed.
- C. Fabricate supports for ceiling hung doors and panel partitions from continuous steel beams of sizes indicated with attached bearing plates, anchors, and braces as indicated. Drill or punch bottom flanges of beams to receive partition track hanger rods; locate holes where indicated on Shop Drawings.
- D. Fabricate framing and supports for solid surface countertops from cast iron and connectors as detailed on Drawings, for table legs.
- E. Galvanize miscellaneous framing and supports where indicated, and in exterior locations.

2.21 CAST NOSINGS

- A. Fabricate units of cast aluminum in sizes and configurations indicated and in lengths necessary to accurately fit openings or conditions. Provide units with an integral abrasive finish consisting of aluminum oxide, silicon carbide, or a combination of both.
- B. Configurations: Provide units in the following configurations, unless otherwise indicated:
 - 1. Nosings: Cross-hatched units, 4 inches (100 mm) wide with 1-inch (25-mm) lip, for casting into concrete steps.
- C. Provide anchors for embedding units integral in concrete.
- D. Apply bituminous paint to concealed bottoms, sides, and edges of units set into concrete.
- E. Manufacturers: Subject to compliance with requirements, provide products by one of the following:

1. American Safety Tread Co., Inc.
2. Amstep Products.
3. Safe-T-Metal Co.
4. Wooster Products Inc.

F. Application: Use at cast-in-place concrete stairs.

2.22 VERTICAL MESH SUNSHADES

A. Provide pre-engineered mesh sunshade system designed to withstand the design forces without permanent deformation or contacting structure behind mesh during peak load conditions, with the following components:

1. Mesh Pattern: Mid-Balance. 50 percent open area.
2. Mesh Type: Flexible
3. Weave Type: Balance weave
4. Materials:
 - a. Spadebolts: T316 stainless steel.
 - b. Binding Material: T316 stainless steel.
 - c. Structural Material; Attachment Tubes and End Caps: Galvanized powder coated steel.
 - d. Mesh: T304 stainless steel.
 - e. Hardware: 18-8 stainless steel.
5. Height and Width: As indicated on Drawings.
6. Intermediate Support Attachment. Required if height is greater than 20 ft
7. Attachment Type: Full height spring tensioned.
8. Attachment System: Severn
 - a. Material: T316L stainless steel.
 - b. Tension System: U-binding and spade bolts.

B. Basis of Design Product: Severn Vertical Fin manufactured by Cambridge Architectural Mesh, or equal.

2.23 METAL BOLLARDS

A. Fabricate metal bollards from Schedule 40 steel pipe.

1. Cap bollards with 1/4-inch-thick, steel plate with domed top.

B. Prime steel bollards with zinc rich primer.

2.24 FINISHES, GENERAL

A. Comply with NAAMM's "Metal Finishes Manual for Architectural and Metal Products" for recommendations for applying and designating finishes.

B. Finish metal fabrications after assembly.

2.25 STEEL AND IRON FINISHES

- A. Galvanizing: Hot-dip galvanize items as indicated to comply with applicable standard listed below:
 - 1. ASTM A 123, for galvanizing steel and iron products.
 - 2. ASTM A 153/A 153M, for galvanizing steel and iron hardware..
- B. Preparation for Shop Priming: Prepare uncoated ferrous-metal surfaces to comply with minimum requirements indicated below for SSPC surface-preparation specifications and environmental exposure conditions of installed metal fabrications:
 - 1. Exteriors (SSPC Zone 1B): SSPC-SP 6/NACE No. 3, "Commercial Blast Cleaning."
 - 2. Interiors (SSPC Zone 1A): SSPC-SP 3, "Power Tool Cleaning."
- C. Apply shop primer to uncoated surfaces of metal fabrications, except those with galvanized finishes indicated as unpainted, and those to be embedded in concrete, sprayed-on fireproofing, or masonry, unless otherwise indicated. Paint embedded steel that is partially exposed on exposed portions and initial 2 inches of embedded areas only.
 - 1. Do not paint surfaces to be welded or high-strength bolted with friction-type connections.
 - 2. Apply 2 coats of paint to surfaces that are inaccessible after assembly or erection. Change color of second coat to distinguish it from first.
- D. Powder Paint: Manufacturer's standard process., in color selected by Architect.

2.26 ALUMINUM FINISHES

- A. Finish designations prefixed by AA comply with the system established by the Aluminum Association for designating aluminum finishes.
- B. As-Fabricated Finish: AA-M10 (Mechanical Finish: as fabricated, unspecified).

2.27 STAINLESS-STEEL FINISHES

- A. Remove tool and die marks and stretch lines or blend into finish.
- B. Grind and polish surfaces to produce uniform, directionally textured, polished finish indicated, free of cross scratches. Run grain with long dimension of each piece.
- C. Directional Satin Finish: No. 4.
- D. When polishing is completed, passivate and rinse surfaces. Remove embedded foreign matter and leave surfaces chemically clean.

PART 3 - EXECUTION

3.1 INSTALLATION, GENERAL

- A. Fastening to In-Place Construction: Provide anchorage devices and fasteners where necessary for securing metal fabrications to in-place construction. Include threaded fasteners for concrete and masonry inserts, toggle bolts, through-bolts, lag bolts, wood screws, and other connectors.
- B. Cutting, Fitting, and Placement: Perform cutting, drilling, and fitting required for installing metal fabrications. Set metal fabrications accurately in location, alignment, and elevation; with edges and surfaces level, plumb, true, and free of rack; and measured from established lines and levels.
- C. Provide temporary bracing or anchors in formwork for items that are to be built into concrete, masonry, or similar construction.
- D. Fit exposed connections accurately together to form hairline joints. Weld connections that are not to be left as exposed joints but cannot be shop welded because of shipping size limitations. Do not weld, cut, or abrade surfaces of exterior units that have been hot-dip galvanized after fabrication and are for bolted or screwed field connections.
- E. Field Welding: Comply with the following requirements:
 - 1. Use materials and methods that minimize distortion and develop strength and corrosion resistance of base metals.
 - 2. Obtain fusion without undercut or overlap.
 - 3. Remove welding flux immediately.
 - 4. At exposed connections, finish exposed welds and surfaces smooth and blended so no roughness shows after finishing and contour of welded surface matches that of adjacent surface.
- F. Corrosion Protection: Coat concealed surfaces of aluminum that will come into contact with grout, concrete, masonry, wood, or dissimilar metals with a heavy coat of bituminous paint.

3.2 INSTALLING METAL STAIRS WITH GROUTED BASEPLATES

- A. Clean concrete and masonry bearing surfaces of bond-reducing materials, and roughen to improve bond to surfaces. Clean bottom surface of baseplates.
- B. Set steel stair baseplates on wedges, shims, or leveling nuts. After stairs have been positioned and aligned, tighten anchor bolts. Do not remove wedges or shims but, if protruding, cut off flush with edge of bearing plate before packing with grout.
 - 1. Use nonmetallic, nonshrink grout, unless otherwise indicated.
 - 2. Pack grout solidly between bearing surfaces and plates to ensure that no voids remain.

3.3 INSTALLING RAILINGS AND HANDRAILS

- A. Adjust handrails and railing systems before anchoring to ensure matching alignment at abutting joints. Space posts at spacing indicated or, if not indicated, as required by design loads. Plumb posts in each direction. Secure posts and railing ends to building construction as follows:
1. Anchor posts to steel by welding directly to steel supporting members.
 2. Use steel pipe sleeves preset and anchored into concrete for installing posts where indicated. After posts have been inserted into sleeves, fill annular space between post and sleeve with nonshrink, nonmetallic grout, mixed and placed to comply with anchoring material manufacturer's written instructions. Leave anchorage joint exposed; wipe off surplus anchoring material; and leave 1/8-inch (3-mm) buildup, sloped away from post.
 3. Where indicated, core-drill holes not less than 5 inches (125 mm) deep and 3/4 inch (20 mm) larger than OD of post for installing posts in concrete. Clean holes of loose material, insert posts, and fill annular space between post and concrete with nonshrink, nonmetallic grout, mixed and placed to comply with anchoring material manufacturer's written instructions
 4. Cover anchorage joint of post with flange of same metal as post where indicated.
 5. Anchor handrail ends to concrete and masonry with steel round flanges welded to rail ends and anchored with postinstalled anchors and bolts.
 6. Anchor railing ends to metal surfaces with flanges bolted to metal surfaces and welded to railing ends.
- B. Attach handrails to wall with wall brackets. Provide bracket with 1-1/2-inch (38-mm) clearance from inside face of handrail and finished wall surface. Locate brackets as indicated or, if not indicated, at spacing required to support structural loads. Secure wall brackets to building construction as follows:
1. Use type of bracket with predrilled hole for exposed bolt anchorage.
 2. For concrete and solid masonry anchorage, use drilled-in expansion shields and hanger or lag bolts.
 3. For hollow masonry anchorage, use toggle bolts.
 4. For steel-framed gypsum board assemblies, use hanger or lag bolts set into wood backing between studs. Coordinate with stud installation to locate backing members

3.4 SETTING BEARING AND LEVELING PLATES

- A. Clean concrete and masonry bearing surfaces of bond-reducing materials, and roughen to improve bond to surfaces. Clean bottom surface of plates.
- B. Set bearing and leveling plates on wedges, shims, or leveling nuts. After bearing members have been positioned and plumbed, tighten anchor bolts. Do not remove wedges or shims but, if protruding, cut off flush with edge of bearing plate before packing with grout.

1. Use nonshrink grout, either metallic or nonmetallic, in concealed locations where not exposed to moisture; use nonshrink, nonmetallic grout in exposed locations, unless otherwise indicated.
2. Pack grout solidly between bearing surfaces and plates to ensure that no voids remain.

3.5 INSTALLING MISCELLANEOUS FRAMING AND SUPPORTS

- A. General: Install framing and supports to comply with requirements of items being supported, including manufacturers' written instructions and requirements indicated on Shop Drawings, if any.
- B. Support steel girders on solid grouted masonry, concrete, or steel pipe columns. Secure girders with anchor bolts embedded in grouted masonry or concrete or with bolts through top plates of pipe columns.
 1. Where grout space under bearing plates is indicated at girders supported on concrete or masonry, install as specified above for setting and grouting bearing and leveling plates.

3.6 INSTALLING NOSINGS

- A. Install with anchorage system indicated to comply with manufacturer's written instructions.
- B. Center nosings on tread widths.
- C. For nosings embedded in concrete steps or curbs, align nosings flush with riser faces and level with tread surfaces.
- D. Seal thresholds exposed to exterior with elastomeric sealant complying with Division 07 Section "Joint Sealants" to provide a watertight installation.

3.7 INSTALLING MESH SUNSCREENS

- A. Install in accordance with manufacturer's instructions, approved submittals and in proper relationship with adjacent construction.
- B. Anchor supports securely with allowance for necessary thermal movement and structural support.
- C. Erect metalwork square, plumb, straight, and true, accurately fitted, with tight joints and intersections.
- D. Do not install component parts that are observed to be defective, including warped, bowed, dented, abraded and broken members.
- E. Do not cut, trim, weld or braze component parts during erection in manner that would damage finish, decrease strength, negate passivation, or result in visual imperfection or

failure in performance. Return component parts that require alteration to shop for re-fabrication, if possible, or for replacement with new parts.

- F. Separate dissimilar metals and use gasket fasteners, isolation shim, or isolation tape where needed to eliminate possibility of corrosive or electrolytic action between metals.

3.8 INSTALLATION OF METAL BOLLARDS

- A. Fill metal-capped bollards solidly with concrete and allow concrete to cure seven days before installing.
- B. Anchor bollards in place with concrete footings. Center and align bollards in holes 3 inches above bottom of excavation. Place concrete and vibrate or tamp for consolidation. Support and brace bollards in position until concrete has cured.

3.9 ADJUSTING AND CLEANING

- A. Touchup Painting: Cleaning and touchup painting of field welds, bolted connections, and abraded areas of shop paint are specified in Division 9 Section "Painting."
- B. Galvanized Surfaces: Clean field welds, bolted connections, and abraded areas and repair galvanizing to comply with ASTM A 780.

END OF SECTION 055000

Room No.	Name	Description	Product/ Color
Millwork Schedule- See drawings for details			
		Window sills, ears/aprons throughout- Solid surface with waterfall edge typ.	
		All cabinets to lock, Finished edge varies see details	
		Plam Tan Echo stained maple edge to blend to match. Provide 3 alt color samples.	
		Wall mounted Coat hooks on Maple Hardwood in Classroom Grade 2-8 see plans/elevations. Detail on A420	
		Provide splash , scheduled or not for countertops, finish to match countertops, typ.	
		Basement	
B03	Copy Room	Upper and base cabinets with plastic laminate countertop/splash	Vertical Surface- Wilsonart Platinum D315-60 , Countertop - Wilsonart Pressed Linen 4991-33 with Charter edge banding Fog F961.
		First Floor	
102	Main Office	Reception desk- Quartz Transaction top, waterfall edge wrap .	Wilsonart Quartz- Grayton Beach Q4039, Base cabinets Vertical Laminate- Wilsonart Pencil wood 7747-58. Main countertop Wilsonart Pressed Linen 4991-33 with Charter edgebanding Fog F961.
		Upper and base cabinets with plastic laminate countertop/splash	Base cabinets Vertical Laminate- Wilsonart Pencil wood 7747-58, Upper cabinets Vertical Laminate -Wilsonart Platinum D315-60 . Countertop- Wilsonart Pressed Linen 4991-33 with Charter Edge banding Fog F961
		Mailboxes	Base cabinets Vertical Laminate- Wilsonart Pencil wood 7747-58, Mailboxes -Wilsonart Platinum D315-60 . Countertop- Wilsonart Quartz- Grayton Beach Q4039
102a	Security	Solid Surface transaction counter (both sides)	Wilsonart Silver Smoke 9226SS
103,104, 112,113,	PreK	PLam Cubby, Hardwood edge	Wilsonart, Tan Echo 7941K-60
		Base cabinet with solid surface sink countertop /splash	Vertical Laminate-Formica, White Microdot 949mc, Countertop- Wilsonart Solid Surface Silver Smoke 9226
		Plastic Laminate bookshelves under the window	Wilsonart, Tan Echo 7941K-60
		Shelving on heavy duty brackets- 12"d x 3H	White
106P/106J	Storage	Shelving on heavy duty brackets- 5H x12"d	White

Millwork Schedule- See drawings for details			
Room No.	Name	Description	Product/ Color
106N	Exam 2	Upper and base cabinets with solid surface countertop/splash	Countertop -Wilsonart Solid surface - Yukon Riverstone 9196RS, Vertical Laminate-Wilsonart White Twill 9285-58
107	Faculty	Upper and base cabinets with solid surface countertop/splash	Countertop -Wilsonart Solid Surface Chilled earth 9228, Vertical laminate- Formica Sarum Twill 8827-58
108	Cafeteria (Social Commons)	Quartz countertop/splash with Plastic Laminate base cabinets	Countertop-Wilsonart Quartz- Grayton Beach Q4039, Base cabinets Vertical Laminate-Wilsonart Pencil wood 7747-58,
		Built in booths with Maple Veneer seat /Phenolic interior surfaces	See spec
Second Floor			
201, 202, 217, 218	Kindergarten	Plam Cubby, Hdwd Maple edges	Wilsonart, Tan Echo 7941K-60
		Base cabinet with solid surface sink countertop /splash	Vertical Laminate-Formica, White Microdot 949mc,Countertop- Wilsonart Solid surface Silver Smoke 9226
		Shelving on heavy duty brackets- 12"d x 3H	White
		Plastic Laminate bookshelves under the window	Wilsonart, Tan Echo 7941K-60
204, 205, 206	Second Grade	Base cabinet with solid surface sink countertop /splash	Vertical Laminate-Formica, White Microdot 949mc, Countertop -Wilsonart Solid surface Silver Smoke 9226
		Plastic laminate teachers desk and upper cabinets	Countertop- Wilsonart Crisp Linen 4942-38 with Charter Dove Grey WD92 edge, Vertical laminate Tan Echo 7941K-60
		Shelving on heavy duty brackets- 12"d x 3H	White
210,211,	First Grade	Plam Cubby, Hdwd Maple edges	
		Base cabinet with solid surface sink countertop /splash	Vertical Laminate-Formica, White Microdot 949mc, Wilsonart Solid surface Silver Smoke 9226
		Plastic laminate teachers desk and upper cabinets	Countertop- Wilsonart Crisp Linen 4942-38 with Charter Dove Grey WD92 edge, Vertical laminate Tan Echo 7941K-60
		Shelving on heavy duty brackets- 12"d x 3H	White

Millwork Schedule- See drawings for details			
Room No.	Name	Description	Product/ Color
215	Learning Commons (Library)	Circulation desk, counter with solid surface top, storage below, Built in Maple upholstered Booth White Board doors- see spec	Countertop /transaction counter-Corian solid surface Antarctica, Vertical laminate(FRP Panels) Sarum Twill 8827-58./Partial Vertical Tile surface see spec See spec for Upholstery
216	Makerspace	Upper and base cabinets with solid surface countertop/splash Shelving on heavy duty brackets- 18"d x 5H Maple Slat wall WhiteBoard doors see spec	Vertical Laminate- Formica White twill 9285-58, Countertop -Corian solid surface -Dove White
220	Special Education	Plastic Laminate bookshelves under the window Base cabinet with solid surface sink countertop /splash Shelving on heavy duty brackets- 12"d x 3H	Wilsonart, Tan Echo 7941K-60 Vertical Laminate-Formica, White Microdot 949mc, Countertop -Wilsonart Solid surface Silver Smoke 9226 White
250	Corridor Nook	Plastic laminate teachers desk and upper cabinets Solid Surface bench	Countertop- Wilsonart Crisp Linen 4942-38 with Charter Dove Grey WD92 edge, Vertical laminater Tan Echo 7941K-60 Corian Natural grey
Third Floor			
301, 302, 317, 318	Fourth grade	Base cabinet with solid surface sink countertop /splash with upper cabinet Plastic laminate teachers desk and upper cabinets	Vertical Laminate-Formica, White Microdot 949mc, Countertop- Wilsonart Solid surface Silver Smoke 9226 Countertop- Wilsonart Crisp Linen 4942-38 with Charter Cove Grey WD92 edge, Vertical laminate- Tan Echo 7941K-60
303	SGI	Plastic Laminate bookshelves under the window	Wilsonart, Tan Echo 7941K-60
304,305,306	Third grade	Base cabinet with solid surface sink countertop /splash with upper cabinet Plastic laminate teachers desk and upper cabinets	Vertical Laminate-Formica, White Microdot 949mc, Countertop-Wilsonart Solid surface Silver Smoke 9226 Countertop- Wilsonart Crisp Linen 4942-38 with Charter Dove Grey WD92 edge, Vertical laminate Tan Echo 7941K-60

Millwork Schedule- See drawings for details			
Room No.	Name	Description	Product/ Color
310,311,	Fifth Grade	Base cabinet with solid surface sink countertop /splash. Upper cabinet	Vertical Laminate-Formica, White Microdot 949mc, Countertop- Wilsonart Solid surface Silver Smoke 9226
		Plastic laminate teachers desk and upper cabinets	Countertop- Wilsonart Crisp Linen 4942-38 with Charter Dove Grey WD92 edge, Vertical laminate Tan Echo 7941K-60
314	Art	Base cabinet with solid surface sink countertop /splash	Countertop-Corian -Dove. Vertical surface - Formica White Twill 9285-58
		Shelving on heavy duty brackets 2H x12"D (Over sink)	White
		Base cabinets with plastic laminate countertop/splash	Vertical Surface- Wilsonart Blueberry Taffy YO355-60. Horizontal and splash- Wilsonart, Washi Crystal 5017-38 with Charter edgebanding Fog F961
314a	Art Storage	Shelving on heavy duty brackets 3H x15"D	White
317a	Storage	Shelving on heavy duty brackets 5H x12"D	White
350	Corridor Nook	Solid Surface Bench	Corian- Natural grey
Fourth Floor			
401, 402, 404,405,406, 410,411,417, 418,419	Sixth-Eighth grade, SE	Base and Upper cabinets with Plam countertop /splash	Countertop-Formica 8958-58 Bubble Art with Charter edgebanding Cement WD503 , Base cabinet- Vertical surface Wilsonart- Cement D503-60, Upper cabinet- Formica Microdot 949MC
		Plastic laminate teachers desk and upper cabinets	Countertop- Wilsonart Crisp Linen 4942-38 with Charter Dove Grey WD92 edge, Vertical laminate Tan Echo 7941K-60
402a	Storage	Shelving on heavy duty brackets 5H x12"D	White
417a	Storage	Shelving on heavy duty brackets 5H x12"D	White
		Plastic laminate teachers desk and upper cabinets	Countertop- Wilsonart Crisp Linen 4942-38 with Charter Dove Grey WD92 edge, Vertical laminate Tan Echo 7941K-60
450	Corridor Nook	Solid Surface bench	Corian- Natural grey
Community Building			
G102	Security	Solid surface transaction counter (both sides)	Wilsonart Silver Smoke 9226SS

SECTION 061053 - MISCELLANEOUS ROUGH CARPENTRY

PART 1 - GENERAL

1.1 SUMMARY

A. This Section includes the following:

1. Wood blocking, cants, furring, supports, and nailers.
2. Plywood backing panels.
3. Plywood ceiling sheathing at canopy.
4. Plywood wall sheathing.
5. Plywood subfloor
6. Rough carriages and framing for wood stairs.

1.2 DEFINITIONS

A. Lumber grading agencies, and the abbreviations used to reference them, include the following:

1. NELMA - Northeastern Lumber Manufacturers Association.
2. NLGA - National Lumber Grades Authority.
3. SPIB - Southern Pine Inspection Bureau.
4. WCLIB - West Coast Lumber Inspection Bureau.
5. WWPA - Western Wood Products Association.

1.3 ACTION SUBMITTALS

A. Product Data: For each type of process and factory-fabricated product. Indicate component materials and dimensions and include construction and application details.

1. Include data for wood-preservative treatment from chemical treatment manufacturer and certification by treating plant that treated materials comply with requirements. Indicate type of preservative used, net amount of preservative retained, and chemical treatment manufacturer's written instructions for handling, storing, installing, and finishing treated material.
2. Include data for fire-retardant treatment from chemical treatment manufacturer and certification by treating plant that treated materials comply with requirements. Include physical properties of treated materials, both before and after exposure to elevated temperatures when tested according to ASTM D 5516 and ASTM D 5664.
3. For products receiving a waterborne treatment, include statement that moisture content of treated materials was reduced to levels specified before shipment to Project site.
4. Include copies of warranties from chemical treatment manufacturers for each type of treatment.

1.4 INFORMATIONAL SUBMITTALS

- A. Material Certificates: For dimension lumber specified to comply with minimum allowable unit stresses.
- B. Research/Evaluation Reports: For the following, showing compliance with building code in effect for Project:
 - 1. Preservative-treated wood.
 - 2. Fire-retardant-treated wood.

1.5 QUALITY ASSURANCE

- A. All composite wood, engineered wood, or agrifiber products (e.g., plywood, particleboard, medium density fiberboard) shall contain no added urea-formaldehyde resins. Laminating adhesives used to fabricate on-site and shop-applied composite wood and agrifiber assemblies shall contain no added urea-formaldehyde resins. Acceptable resins and binders include, but are not limited to, phenol formaldehyde and methyl diisocyanate (MDI).

1.6 DELIVERY, STORAGE, AND HANDLING

- A. Stack lumber, plywood, and other panels; place spacers between each bundle to provide air circulation. Provide for air circulation around stacks and under coverings..

PART 2 - PRODUCTS

2.1 WOOD PRODUCTS, GENERAL

- A. Lumber: DOC PS 20 and applicable rules of lumber grading agencies certified by the American Lumber Standards Committee Board of Review.
 - 1. Factory mark each piece of lumber with grade stamp of grading agency.
 - 2. Provide dressed lumber, S4S, unless otherwise indicated.
 - 3. Provide dry lumber with 19 percent maximum moisture content at time of dressing for 2-inch nominal (38-mm actual) thickness or less, unless otherwise indicated.

2.2 WOOD-PRESERVATIVE-TREATED MATERIALS

- A. Preservative Treatment by Pressure Process: AWPA U1; Use Category UC2 for interior construction not in contact with ground, and Use Category UC3b for exterior construction not in contact with ground.
 - 1. Preservative Chemicals: Acceptable to authorities having jurisdiction and containing no arsenic or chromium. Do not use inorganic boron (SBX) for sill plates.
 - 2. The use of CCA preservative treated wood is prohibited.

- B. Kiln-dry material after treatment to a maximum moisture content of 19 percent for lumber and 15 percent for plywood.
- C. Mark each treated item with treatment quality mark of an inspection agency approved by the American Lumber Standards Committee Board of Review.
- D. Application: Treat items indicated on Drawings, and the following:
 - 1. Wood cants, nailers, curbs, equipment support bases, blocking, stripping, and similar members in connection with roofing, flashing, vapor barriers, and waterproofing.
 - 2. Wood sills, sleepers, blocking, furring, stripping, and similar concealed members in contact with masonry or concrete.

2.3 FIRE-RETARDANT-TREATED MATERIALS

- A. General: Where fire-retardant-treated materials are indicated, materials shall comply with requirements in this article, that are acceptable to authorities having jurisdiction, and with fire-test-response characteristics specified as determined by testing identical products per test method indicated by a qualified testing agency.
- B. Fire-Retardant-Treated Lumber and Plywood by Pressure Process: Products with a flame-spread index of 25 or less when tested according to ASTM E84, and with no evidence of significant progressive combustion when the test is extended an additional 20 minutes, and with the flame front not extending more than 10.5 feet beyond the centerline of the burners at any time during the test.
 - 1. Use treatment that does not promote corrosion of metal fasteners.
 - 2. Exterior Type: Treated materials shall comply with requirements specified above for fire-retardant-treated lumber and plywood by pressure process after being subjected to accelerated weathering according to ASTM D2898. Use for exterior locations and where indicated.
 - 3. Interior Type A: Treated materials shall have a moisture content of 28 percent or less when tested according to ASTM D3201 at 92 percent relative humidity. Use where exterior type is not indicated.
- C. Identify fire-retardant-treated wood with appropriate classification marking of qualified testing agency

2.4 DIMENSION LUMBER FRAMING

- A. General: Provide dimension lumber of grades indicated according to the American Lumber Standards Committee National Grading Rule provisions of the grading agency indicated.
- B. Stair Framing: No. 2 grade Douglas fir-larch; WCLIB or WWPA, minimum.

2.5 MISCELLANEOUS LUMBER

- A. Provide miscellaneous lumber for support or attachment of other construction, including the following:
 - 1. Blocking.
 - 2. Nailers.
 - 3. Furring.
 - 4. Sleepers
 - 5. Cants
- B. For items of dimension lumber size, provide Construction, Stud, or No. 2 grade lumber with 19 percent maximum moisture content and the following species: Mixed southern pine; SPIB.
- C. For concealed boards, provide lumber with 19 percent maximum moisture content of the following species and grades:
 - 1. Spruce-pine-fir (south) or Spruce-pine-fir, Construction or 2 Common grade; NELMA, NLGA, WCLIB, or WWPA.

2.6 PLYWOOD PANELS

- A. Telephone and Electrical Equipment Backing Panels: DOC PS 1, Exposure 1, C-D Plugged, fire-retardant treated, in thickness indicated or, if not indicated, not less than 1/2 inch (12.7 mm) thick.
 - 1. Paint before mounting of equipment.
- B. Plywood Ceiling Sheathing: DOC PS 1; Exposure 1, Structural I sheathing; span rating to suit framing in each location and in thickness indicated.
- C. Plywood Wall Sheathing: DOC PS 1; Exposure 1, Structural I sheathing; span rating to suit framing in each location and in thickness indicated.
- D. Plywood Subfloor: DOC PS 1, Exposure 1, Structural I sheathing; span rating to suit framing in each location and in thickness indicated.
- E. Miscellaneous Concealed Plywood: Exposure 1 sheathing, span rating to suit framing in each location, and thickness as indicated but not less than 1/2 inch (13 mm).
 - 1. Provide fire-retardant-treated panels for interior locations unless indicated.
 - 2. Provide preservative-treated panels for exterior locations unless indicated.

2.7 MISCELLANEOUS MATERIALS

- A. Fasteners:

1. Where rough carpentry is exposed to weather, in ground contact, or in area of high relative humidity, provide fasteners with hot-dip zinc coating complying with ASTM A 153/A 153M.
2. Bolts: Steel bolts complying with ASTM A 307, Grade A (ASTM F 568M, Property Class 4.6); with ASTM A 563 (ASTM A 563M) hex nuts and, where indicated, flat washers.

2.8 ACCESSORY MATERIALS

- A. Weather Resistant Barrier: Asphalt-saturated organic felt, ASTM D 226, Type 1 (No. 15 asphalt felt), unperforated.

PART 3 - EXECUTION

3.1 INSTALLATION

- A. Discard units of material with defects that impair quality of carpentry and that are too small to use with minimum number of joints or optimum joint arrangement.
- B. Set rough carpentry to required levels and lines, with members plumb, true to line, cut, and fitted. Fit rough carpentry to other construction; scribe and cope as needed for accurate fit. Locate furring, nailers, blocking, and similar supports to comply with requirements for attaching other construction.
- C. Apply field treatment complying with AWWA M4 to cut surfaces of preservative-treated lumber and plywood.
- D. Securely attach carpentry work as indicated and according to applicable codes and recognized standards.
- E. Use fasteners of appropriate type and length. Predrill members when necessary to avoid splitting wood.

3.2 PANEL PRODUCT INSTALLATION

- A. Fastening Methods: Fasten panels as indicated below:
 1. Plywood Backing Panels: Screw to supports.
 2. Miscellaneous Concealed Plywood Panels: Screw to supports.
 3. Wall Sheathing: Screw to supports.
 4. Ceiling Sheathing: Screw to supports.
 5. Subflooring:
 - a. Glue and nail to wood framing.
 - b. Space panels 1/8 inch (3 mm) apart at edges and ends.

3.3 WOOD BLOCKING, AND NAILER INSTALLATION

- A. Install where indicated and where required for screeding or attaching other work. Form to shapes indicated and cut as required for true line and level of attached work. Coordinate locations with other work involved.
- B. Attach items to substrates to support applied loading. Recess bolts and nuts flush with surfaces, unless otherwise indicated.

3.4 INSTALLATION OF STAIR FRAMING

- A. Provide stair framing members of size, space, and configuration indicated or, if not indicated, to comply with the following requirements:
 - 1. Size: 2-by-12-inch nominal (38-by-286-mm actual) size, minimum.
 - 2. Material: Solid lumber.
 - 3. Notching: Notch rough carriages to receive treads, risers, and supports; leave at least 3-1/2 inches (89 mm) of effective depth.
 - 4. Spacing: At least three framing members for each 36-inch (914-mm) clear width of stair.
- B. Provide stair framing with no more than 3/16-inch (4.7-mm) variation between adjacent treads and risers and no more than 3/8-inch (9.5-mm) variation between largest and smallest treads and risers within each flight.

END OF SECTION 061053

SECTION 061643 - GYPSUM SHEATHING

PART 1 - GENERAL

1.1 SUMMARY

A. Section Includes:

1. Wall sheathing.
2. Sheathing joint and penetration treatment.

B. Related Requirements:

1. Division 07 Section "Fluid-Applied Membrane Air and Moisture Barriers" for moisture-resistive barrier applied over wall sheathing.

1.2 ACTION SUBMITTALS

- A. Product Data: For each type of product.

1.3 QUALITY ASSURANCE

- A. Source Limitations: Obtain each gypsum sheathing product through one source from a single manufacturer.

1.4 DELIVERY, STORAGE, AND HANDLING

- A. Stack panels flat with spacers beneath and between each bundle to provide air circulation. Protect sheathing from weather by covering with waterproof sheeting, securely anchored. Provide for air circulation around stacks and under coverings.

1.5 SEQUENCING AND SCHEDULING

- A. Sequence installing sheathing with installing exterior cladding to comply with requirements indicated below:
1. Do not leave glass-mat gypsum sheathing board exposed to weather for more than 180 days.

PART 2 - PRODUCTS

2.1 PERFORMANCE REQUIREMENTS

- A. Fire-Test-Response Characteristics: For assemblies with fire-resistance ratings, provide materials and construction identical to those of assemblies tested for fire resistance per ASTM E 119 by a testing and inspecting agency acceptable to authorities having jurisdiction.

1. Fire-Resistance Ratings: Indicated by design designations from UL's "Fire Resistance Directory," or GA-600, "Fire Resistance Design Manual."

- B. Vertical and Lateral Fire Propagation Test Characteristics: The exterior wall assembly of the School Building is required to comply with NFPA 285 "Standard Method of Test for the Evaluation of Flammability Characteristics of Exterior Nonload-bearing Wall Assemblies Containing Combustible Components." The base wall, stud cavity insulation, wall sheathing, air barrier, continuous wall rigid insulation and exterior cladding are components that are required to be to be evaluated as part of this specific assembly test. Gypsum sheathing shall be part of an assembly that has passed NFPA 285 testing.

2.2 GYPSUM SHEATHING, GENERAL

- A. Size: Provide maximum lengths and widths available that will minimize joints in each area and that correspond with support system indicated

2.3 WALL SHEATHING

- A. Glass-Mat Gypsum Wall Sheathing: ASTM C 1177/1177M.

1. Products: Subject to compliance with requirements, available products that may be incorporated into the Work include, but are not limited to, the following:
 - a. National Gypsum Company; Gold Bond e(2)XP.
 - b. United States Gypsum Co.; Securock.
 - c. Georgia Pacific; DensGlass
2. Type and Thickness: Type X, 5/8 inch (15.9 mm) thick.
3. Size: 48 by 96 inches (1219 by 2438 mm) or 48 by 120 inches (1219 by 3048 mm) for vertical installation.

2.4 FASTENERS

- A. General: Provide fasteners of size and type indicated that comply with requirements specified in this article for material and manufacture.
- B. Screws for Fastening Gypsum Sheathing to Cold-Formed Metal Framing: Steel drill screws, in length recommended by sheathing manufacturer for thickness of sheathing to be attached, with organic-polymer or other corrosion-protective coating having a salt-spray resistance of more than 800 hours according to ASTM B 117.
 1. For steel framing from 0.033 to 0.112 inch (0.84 to 2.84 mm) thick, use screws that comply with ASTM C 954.

2.5 SHEATHING JOINT-AND-PENETRATION TREATMENT MATERIALS

- A. Sealant for Glass-Mat Gypsum Sheathing: Silicone emulsion sealant complying with ASTM C 834, compatible with sheathing tape and sheathing and recommended by

tape and sheathing manufacturers for use with glass-fiber sheathing tape and for covering exposed fasteners.

1. Sheathing Tape: Self-adhering glass-fiber tape, minimum 2 inches (50 mm) wide, 10 by 10 or 10 by 20 threads/inch (390 by 390 or 390 by 780 threads/m), of type recommended by sheathing and tape manufacturers for use with silicone emulsion sealant in sealing joints in glass-mat gypsum sheathing and with a history of successful in-service use.
2. VOC Content: 250 g/L or less when calculated according to 40 CFR 59, Subpart D (EPA Method 24) and complying with VOC content limits of authorities having jurisdiction.
3. Sealants and tapes shall be compatible with air and moisture barrier specified in Section 072726

PART 3 - EXECUTION

3.1 INSTALLATION, GENERAL

- A. Do not use materials with defects that impair quality of sheathing or pieces that are too small to use with minimum number of joints or optimum joint arrangement. Arrange joints so that pieces do not span between fewer than three support members.
- B. Cut panels at penetrations, edges, and other obstructions of work; fit tightly against abutting construction unless otherwise indicated.
- C. Securely attach to substrate by fastening as indicated, complying with manufacturer's published instructions.
- D. Coordinate wall sheathing installation with air and moisture barrier installation so these materials are installed in sequence and manner that prevent exterior moisture from passing through completed assembly.
- E. Do not bridge building expansion joints; cut and space edges of panels to match spacing of structural support elements.

3.2 GYPSUM SHEATHING INSTALLATION

- A. Comply with GA-253 and with manufacturer's written instructions.
 1. Fasten gypsum sheathing to cold-formed metal framing with screws.
 2. Install boards with a 3/8-inch (9.5-mm) gap where non-load-bearing construction abuts structural elements.
 3. Install boards with a 1/4-inch (6.4-mm) gap where they abut masonry or similar materials that might retain moisture, to prevent wicking.
- B. Apply fasteners so heads bear tightly against face of sheathing, but do not cut into facing.

- C. Vertical Installation: Install board vertical edges centered over studs. Abut ends and edges of each board with those of adjacent boards. Attach boards at perimeter and within field of board to each stud.
 - 1. Space fasteners approximately 8 inches (200 mm) o.c. and set back a minimum of 3/8 inch (9.5 mm) from edges and ends of boards.
- D. Seal sheathing joints according to sheathing manufacturer's written instructions.
 - 1. Apply elastomeric sealant to joints and fasteners and trowel flat. Apply sufficient amount of sealant to completely cover joints and fasteners after troweling. Seal other penetrations and openings.
 - 2. Apply glass-fiber sheathing tape to glass-mat gypsum sheathing joints and apply and trowel silicone emulsion sealant to embed entire face of tape in sealant. Apply sealant to exposed fasteners with a trowel so fasteners are completely covered. Seal other penetrations and openings.

END OF SECTION 061643

SECTION 064020 - INTERIOR ARCHITECTURAL WOODWORK

PART 1 - GENERAL

1.1 SUMMARY

A. This Section includes the following:

1. Plastic-laminate cabinets and casework.
2. Wood cabinets and casework, including built-in bookcases and storage units.
3. Interior wood trim and rails
4. Plastic laminate countertops.
5. Plastic laminate cubbies.
6. Coat hooks, wall mounted, for classrooms.
7. Wood seating (banquette)
8. Seating upholstery for seating units.
9. Sliding whiteboard doors for built-in bookcases.
10. Wood stairs.
11. Wood surround at Proscenium opening.
12. Slat wall.

B. Refer to the Schedule of Millwork for scope required.

C. Related Work Specified Elsewhere:

1. Solid surface countertops are specified in Division 06 Section "Solid Surface Material Fabrications."
2. FRP panel cladding for Learning Commons casework and columns and Cafeteria booths are specified in Division 09 Section "Fiberglass Reinforced Plastic Panels."
3. Composite quartz countertops are specified in Division 12 Section "Simulated Stone Countertops."

1.2 DEFINITIONS

- A. Interior architectural woodwork includes wood furring, blocking, shims, and hanging strips for installing woodwork items, unless concealed within other construction before woodwork installation.
- B. Rough carriages for stairs are a part of interior architectural woodwork. Rough framing members associated with stairwork are specified in Division 06 "Miscellaneous Rough Carpentry" and Division 09 Section "Non-Structural Metal Framing."

1.3 SUBMITTALS

- A. Product Data: For each type of product indicated, including cabinet hardware and accessories, and finishing materials and processes.

- B. Shop Drawings: Show location of each item, dimensioned plans and elevations, large-scale details, attachment devices, and other components.
 - 1. Show details full size.
 - 2. Show locations and sizes of furring, blocking, and hanging strips and clips, cabling and connectors, and attachment devices, including concealed blocking and reinforcement specified in other Sections.
 - 3. Show locations and sizes of cutouts and holes for plumbing fixtures, faucets, soap dispensers, wire management, and other items installed in architectural woodwork.
 - 4. Show locations of seams in countertops.

- C. Samples for Verification: For the following:
 - 1. Lumber with or for transparent finish, 50 sq. in. (300 sq. cm), for each species and cut, finished on 1 side and 1 edge.
 - 2. Wood-veneer-faced panel products with or for transparent finish, 8 by 10 inches (200 by 250 mm), for each species and cut. Include at least one face-veneer seam and finish as specified.
 - 3. Plastic-laminate-clad products, 8 by 10 inches (200 by 250 mm), for each type, color, pattern, and surface finish.
 - 4. Upholstery fabric, 8 by 10 inches (200 by 250 mm), for each type.
 - 5. Markerboard Panels: 6 inches (150 mm) square, showing exposed-edge finish.

- D. Product Certificates: Signed by manufacturers of woodwork certifying that products furnished comply with requirements.

- E. Qualification Data: For firms and persons specified in "Quality Assurance" Article to demonstrate their capabilities and experience. Include lists of completed projects with project names and addresses, names and addresses of architects and owners, and other information specified.

1.4 QUALITY ASSURANCE

- A. Installer Qualifications: An experienced installer who has completed architectural woodwork similar in material, design, and extent to that indicated for this Project and whose work has resulted in construction with a record of successful in-service performance.

- B. Source Limitations: Engage a qualified woodworking firm to assume undivided responsibility for production and installation of interior architectural woodwork.

- C. Quality Standard: Unless otherwise indicated, comply with AWI's "Architectural Woodwork Quality Standards" for grades of interior architectural woodwork, construction, finishes, and other requirements.
 - 1. Provide AWI Quality Certification Program certificate indicating that woodwork complies with requirements of grades specified.

- D. Fire-Test-Response Characteristics of Upholstered Chairs:

1. Upholstery Assembly: Assembly shall comply with component-testing requirements of California Technical Bulletin 117-2013.

1.5 DELIVERY, STORAGE, AND HANDLING

- A. Do not deliver woodwork until painting and similar operations that could damage woodwork have been completed in installation areas. If woodwork must be stored in other than installation areas, store only in areas where environmental conditions comply with requirements specified in "Project Conditions" Article.

1.6 PROJECT CONDITIONS

- A. Environmental Limitations: Do not deliver or install woodwork until building is enclosed, wet work is complete, and HVAC system is operating and maintaining temperature and relative humidity at occupancy levels during the remainder of the construction period.
- B. Field Measurements: Where woodwork is indicated to fit to other construction, verify dimensions of other construction by field measurements before fabrication and indicate measurements on Shop Drawings. Coordinate fabrication schedule with construction progress to avoid delaying the Work.
 1. Locate concealed framing, blocking, and reinforcements that support woodwork by field measurements before being enclosed and indicate measurements on Shop Drawings.

1.7 COORDINATION

- A. Coordinate sizes and locations of framing, blocking, furring, reinforcements, and other related units of Work specified in other Sections to ensure that interior architectural woodwork can be supported and installed as indicated.

PART 2 - PRODUCTS

2.1 MATERIALS, GENERAL

- A. General: Provide materials that comply with requirements of the AWI quality standard for each type of woodwork and quality grade specified, unless otherwise indicated.
- B. Low-Emitting Materials: All composite wood, engineered wood, or agrifiber products (e.g., plywood, particleboard, medium density fiberboard) shall contain no added urea-formaldehyde resins. Laminating adhesives used to fabricate on-site and shop-applied composite wood and agrifiber assemblies shall contain no added urea-formaldehyde resins. Acceptable resins and binders include, but are not limited to, phenol formaldehyde and methyl diisocyanate (MDI)
- C. Wood Species and Cut for Transparent Finish: Grade A Maple, plain sawn/sliced.

1. Matching: Solid stock shall be matched for color and grain; veneer faces shall be compatible in color with solid stock.
 2. Veneer Matching: Slip matched and balanced within panel.
 3. Maple edge on casework shall match the approved submittal on maple door finish.
- D. Wood Species for Stair Treads and Risers: Match wood flooring species, format and color at stage; refer to Division 09 Section "Wood Athletic Flooring."
- E. Cabinet Interiors (Cabinets with Doors): Plastic laminate with 3 mm PVC edgebanding (kerf and adhesion installation) on shelves.
- F. Wood Products: Comply with the following:
1. Hardboard: Tempered, S1S, Class 1 minimum 1/4 inch and conforming to PS 58-73.
 2. Particleboard: Minimum 45 lb. density particleboard complying with requirements in ANSI A208.1, Grade M - 3i.
 3. Medium-Density Fiberboard: ANSI A208.2, Grade 130
 4. Softwood Plywood: DOC PS 1, Medium Density Overlay.
 5. Hardwood Plywood and Face Veneers: HPVA HP-1.
- G. Melamine-Faced Particleboard: Particleboard complying with ANSI A208.1, Grade M-2, finished on both faces with thermally fused, melamine-impregnated decorative paper and complying with requirements of NEMA LD3, Grade VGL, for test methods 3.3, 3.4, 3.6, 3.8, and 3.10.
1. Provide PVC or polyester edge banding complying with LMA EDG-1 on components with exposed or semiexposed edges.
- H. High-Pressure Decorative Laminate: NEMA LD 3, grades as indicated, or if not indicated, as required by woodwork quality standard.
1. Colors, Patterns and Finishes: As scheduled, or if not scheduled as selected by Architect.
 2. Basis of Design Products: As scheduled, or if not scheduled as selected by Architect.
 3. Available Manufacturers: Subject to compliance with requirements, manufacturers offering high-pressure decorative laminates that may be incorporated into the Work include, but are not limited to, the following:
 - a. Formica Corporation.
 - b. Laminart.
 - c. Panolam Industries International, Inc.
 - d. Wilsonart
- I. Adhesive for Bonding Plastic Laminate: Contact cement.
1. Adhesive for Bonding Edges: Hot-melt adhesive or adhesive specified above for faces.

- J. Sliding Whiteboard Doors for Bookcases and Other Locations as Indicated: Interior sliding aluminum-framed door system with magnetic whiteboard finish one side, bottom-rolling doors, door tracks and hardware.
1. Basis-of-Design Product: Provide System S42 by Raumplus North America, Inc. or equal, with the following attributes.
 - a. Stile/Profile: S3000 Symmetrical, extruded aluminum with clear anodized finish.
 - b. Depth: 42 mm (1-5/8")
 - c. Panel Faces:
 - 1) Front: Magnetic markerboard 6 mm thick (1/4")
 - 2) Rear: MDF 6 mm thick (1/4"); paint in field.
 - d. Tracks: Clean anodized aluminum extrusions.
 - 1) Top Track: Double top track 40 mm with end covers as required.
 - 2) Bottom Tracks: Double surface-mounted bottom track with inset cover.
 - e. Hardware: Top Knobs, Raumplus 10.20 rod handle 1'-0" HT. One pair for each set of doors. Finish: Brushed Satin Nickel
 - f. Markerboard Accessories: Provide magnetic markerboard tray 12" wide for each markerboard.
 - g. Accessories: Provide guide rails, rollers, door stops, floor guides, door steady, connectors, fasteners and all required accessories for complete assembly.
- K. VOC Limits for Installation Adhesives and Glues: Use installation adhesives that comply with the following limits for VOC content when calculated according to 40 CFR 59, Subpart D (EPA Method 24):
1. Wood Glues: 30 g/L.
 2. Contact Adhesive: 80 g/L.
- L. Glass for Swinging Cabinet Doors and for Glass Shelves: Clear Tempered Glass, 1/2" thick, as specified in Division 08 Section "Glazing."
- M. Upholstery Fabric: 100% polyurethane (polycarbonate) fabric 54" wide with Write-Off ink and stain resistant finish and polyester backing, with a weight of 1.53 lbs./yd., and the following:
1. Flammability: Meets NFPA 260 and UFAC Class 1 for cigarette ignition resistance, and California Technical Bulletin 117-2013.
 2. Repeat: 2.1"V 3.4"H
 3. Basis of Design Product: Tessellation by Architex, or equal.
 4. Color: Bayleaf
- N. Upholstery Foam: Combustion Modified High Resilient (CMHR) foam meeting the following:
1. Density: 3.0 lb/cu ft
 2. 25% ILD: 35 lb
 3. Support Factor: 2.6
 4. Resiliency: 45%
 5. Meets California Technical Bulletins 117-2013 and 133 and NFPA 260.

6. Basis of Design Product: Code Red II foam by Hickory Springs Manufacturing, or equal.

O. Springs for Upholstered Seating: Sinuous springs with cross-connecting links. Springs shall be fabricated from high-carbon, high-tensile oil-tempered spring wire in 9 gauge for seats and 11 gauge for seat backs.

2.2 CABINET HARDWARE AND ACCESSORIES

A. General: Provide cabinet hardware and accessory materials associated with architectural cabinets, except for items specified in Division 08 Section "Door Hardware."

B. Exposed Hardware Finishes: For exposed hardware, provide finish that complies with BHMA A156.18 for BHMA finish number indicated.

1. Satin Chromium Plated: BHMA 626 for brass or bronze base; BHMA 652 for steel base.

2. Other specific finishes are scheduled on Drawings

C. Bumpers: Clear pressure sensitive non-skid vinyl bumpers 1/2 inch diameter by 5/32 inches thick; Grass #GF-BP-C, or equivalent.

D. Frameless Concealed Hinges (European Type): 180 degrees of opening, self-closing, three-way adjustable; Grass #GF-1200VX-8, or equivalent.

E. Catches: Magnetic catches, 5 lb. holding power; Ives 324-P69, or equivalent. Provide 1 top mounted at each door.

F. Pulls: Mockett Rounded Square Pull #1088-SS Platinum finish.

G. Wire Management Grommets: Plastic grommets with cut-out covers cap, 1-1/2 inch I.D. unless otherwise indicated; Hughes Plastic Parts, or equivalent. Color as selected by Architect from manufacturer's standard colors.

H. Drawer Slides: 3/4 extension type, constructed from zinc plated cold-rolled steel, with ball-bearing rollers, 75 lbf (330 N) load rated; Accuride 214 Series, or equivalent.

I. Slides for File Drawers: Full extension type, constructed from zinc plated cold-rolled steel, with ball-bearing rollers, 200 lbf (890 N) load rated; Accuride 4437 Series, or equivalent.

J. Pencil Drawer Slides: 45 lbf (200 N), Accuride 214 Series, or equivalent

K. Adjustable Shelf Supports: Peg type, steel, 5/16" stem length, 1/4" bore, spoon width 25/64"; Progressive IF-739NP, or equivalent.

L. Locks: Door locks - NL-C8173-26D; drawer locks - NL-C8178-26D; strike - NL-C2004-14A; National Cabinet Lock, or equivalent. Keyed as requested by Owner.

- M. Levelers: Plastic leveling system, including socket, leveler, toe kick clip, and toe kick handle; Camar model CM-835-E1-00, CM-345-10-P2, CM-202-V1-T2, and CM-230-01-DE, or equivalent.
- N. Hooks for Cubbies: Double-pronged stainless steel hooks, ceiling mounted.

2.3 ACCESSORIES

- A. Shelving: 3/4" thick with 3 mm PVC kerfed edges, unless otherwise indicated.
 - 1. Provide MDO plywood for painted shelving.
 - 2. Provide wood veneered panel product with solid wood edge where scheduled or indicated on drawings.
 - 3. Provide plastic laminate faced panel product where scheduled or indicated on drawings.
 - 4. Shelving as part of a bookcase assembly shall be 1" thick.
- B. Adjustable Shelf Supports: Decorative, heavy-duty double-slotted standards adjustable on 1-1/4" centers with decorative brackets in length indicated on drawings. Include all accessories including cover strips, end caps, joiners, spacers and fasteners, as required for complete installation. Provide with epoxy finish in color as selected by Architect from manufacturer's standards.
 - 1. Product: Knap & Vogt #82 standards and #182 brackets, or equivalent.
- C. Countertop Support: Rakks EH Surface Mount Bracket RAKKS #EH1824 or equal.
 - 1. Finish: White or grey powder paint finish as selected by Architect.
- D. Coat Hooks, Wall-Mounted, for Classrooms: Single piece of 1/8" thick hot-rolled steel plate shaped into hook with 45 degree upper and lower prong angles; 3/4" wide x 4-3/16" h x 1-1/4" d; with two 3/16" OD screw holes, and load capacity of 150 lbs., as follows:
 - 1. Basis of Design Product: Mini Doohooky by Shelfology, or equal.
 - 2. Colors: Four colors as selected by Architect.
- E. Slatwall: Provide maple Slatwall in size 6' x 4' with finished edge trim and aluminum insert channels. Provide the following accessories:
 - 1. One carton wire baskets (quantity 6 baskets) S-22887 - 12" x 5" x 6"
 - 2. One carton Slatwall shelves (quantity 4 shelves) H-3882 in white 14"w x 8"d

2.4 INSTALLATION MATERIALS

- A. Anchors: Select material, type, size, and finish required for each substrate for secure anchorage. Provide nonferrous-metal or hot-dip galvanized anchors and inserts on inside face of exterior walls and elsewhere as required for corrosion resistance. Provide toothed-steel or lead expansion sleeves for drilled-in-place anchors.

- B. Rough Carriages for Stairs: Comply with requirements in Division 06 Section "Miscellaneous Rough Carpentry." Kiln-dry to less than 15 percent moisture content.

2.5 FABRICATION, GENERAL

- A. Interior Woodwork Grade: Provide Premium grade interior woodwork complying with the referenced quality standard.
- B. Wood Moisture Content: Comply with requirements of referenced quality standard for wood moisture content in relation to ambient relative humidity during fabrication and in installation areas.
- C. Fabricate woodwork to dimensions, profiles, and details indicated. Ease edges to radius indicated for the following:
 - 1. Corners of Cabinets and Edges of Solid-Wood (Lumber) Members and Rails: 1/16 inch (1.5 mm)
- D. Complete fabrication, including assembly, and hardware application, to maximum extent possible, before shipment to Project site. Disassemble components only as necessary for shipment and installation. Where necessary for fitting at site, provide ample allowance for scribing, trimming, and fitting.
 - 1. Trial fit assemblies at fabrication shop that cannot be shipped completely assembled. Install dowels, screws, bolted connectors, and other fastening devices that can be removed after trial fitting. Verify that various parts fit as intended and check measurements of assemblies against field measurements indicated on Shop Drawings before disassembling for shipment.
- E. Shop cut openings, to maximum extent possible, to receive hardware, appliances, plumbing fixtures, electrical work, and similar items. Locate openings accurately and use templates or roughing-in diagrams to produce accurately sized and shaped openings. Sand edges of cutouts to remove splinters and burrs.
 - 1. Seal edges of openings in countertops with a coat of varnish.
- F. Stairs: Cut rough carriages to accurately fit treads and risers.
 - 1. Glue treads to risers, and glue and nail treads and risers to carriages.
 - 2. House wall and face stringers, and glue and wedge treads and risers.
 - 3. Fabricate stairs with treads and risers no more than 1/8 inch (3 mm) from indicated position and no more than 1/16 inch (1.5 mm) out of relative position for adjacent treads and risers.

2.6 INTERIOR WOOD TRIM AND RAILS

- A. Quality Standard: Comply with AWI Section 6.

- B. Grade: Premium, for transparent finish items.
- C. For trim items wider than available lumber, use veneered construction. Do not glue for width.
- D. Backout or groove backs of flat trim members and kerf backs of other wide, flat members, except for members with ends exposed in finished work
- E. Assemble casings in plant except where limitations of access to place of installation require field assembly.
- F. Assemble moldings in plant to maximum extent possible. Miter corners in plant and prepare for field assembly with bolted fittings designed to pull connections together.

2.7 WOOD CABINETS AND CASEWORK FOR TRANSPARENT FINISH

- A. Quality Standard: Comply with AWI Section 10 requirements for custom wood cabinets.
- B. Grade:
 - 1. Premium, for transparent finish items.
- C. AWI Type of Cabinet Construction: Flush overlay.
- D. Wood Species and Cut for Exposed Surfaces: As specified above.
- E. Grain and Veneer Matching: As specified above
- F. Semiexposed Surfaces: Provide surface materials indicated below:
 - 1. All cabinet interiors (at cabinets with doors) shall be plastic laminate faced with edgebanding as specified above
 - 2. Drawer Sides and Backs: Thermoset decorative overlay.
 - 3. Drawer Bottoms: Thermoset decorative overlay.
- G. Provide dust panels of 1/4-inch (6.4-mm) plywood or tempered hardboard above compartments and drawers, unless located directly under tops

2.8 PLASTIC-LAMINATE CABINETS AND CASEWORK

- A. Quality Standard: Comply with AWI Section 10 requirements for custom laminate cabinets.
- B. Grade: Premium
- C. AWI Type of Cabinet Construction: Full overlay.

- D. Laminate Cladding for Exposed Surfaces: High-pressure decorative laminate complying with the following requirements:
 - 1. Horizontal Surfaces Other Than Tops: HGS.
 - 2. Postformed Surfaces: HGP.
 - 3. Vertical Surfaces: HGS.
 - 4. Edges: HGS
 - 5. For the main office reception desk laminate, provide Wilsonart High Wear laminate in type General Purpose (HGS) Type 107HW, or equal.
- E. Materials for Semiexposed Surfaces Other Than Drawer Bodies:
 - 1. Drawer Sides and Backs: Thermoset decorative overlay.
 - 2. Drawer Bottoms: Thermoset decorative overlay.
- F. Colors, Patterns, and Finishes: As scheduled, or if not scheduled, as selected by Architect.
- G. Substrate: Plywood.
- H. Provide dust panels of 1/4-inch (6.4-mm) plywood or tempered hardboard above compartments and drawers, unless located directly under tops.

2.9 PLASTIC LAMINATE COUNTERTOPS

- A. Quality Standard: Comply with AWI Section 11 requirements for high-pressure decorative laminate countertops.
- B. Grade: Custom.
- C. High-Pressure Decorative Laminate Grade: HGS.
- D. Colors, Patterns, and Finishes: As scheduled, or if not scheduled, as selected by Architect.
- E. Edge Treatment: As indicated on Drawings.
- F. Core Material: Particleboard or medium-density fiberboard.
- G. Core Material at Sinks: Particleboard made with exterior glue, or medium-density fiberboard made with exterior glue
- H. Backing: Provide all laminate counter tops with backer/balance sheets.
- I. Provide backsplashes and end splashed as indicated.

2.10 STAIRWORK AND HANDRAILS

- A. Quality Standard: Comply with AWI Section 7.
- B. Grade: Premium.
- C. Wood Species: As specified above.
- D. Finishes for Stair Parts: Transparent finish; comply with Division 09 Section "Wood Flooring."

2.11 SHOP FINISHING

- A. Quality Standard: Comply with AWI Section 5, unless otherwise indicated.
 - 1. Grade: Provide finishes of same grades as items to be finished.
- B. General:
 - 1. Finish all transparent finished architectural woodwork at fabrication shop as specified in this Section. Defer only final touchup, cleaning, and polishing until after installation.
- C. Preparations for Finishing: Comply with referenced quality standard for sanding, filling countersunk fasteners, sealing concealed surfaces, and similar preparations for finishing architectural woodwork, as applicable to each unit of work.
 - 1. Backpriming: Apply one coat of sealer or primer, compatible with finish coats, to concealed surfaces of woodwork. Apply two coats to back of paneling and to end-grain surfaces. Concealed surfaces of plastic-laminate-clad woodwork do not require backpriming when surfaced with plastic laminate, backing paper, or thermoset decorative overlay.
- D. Transparent Finish: Comply with requirements indicated below for grade, finish system, staining, and sheen, with sheen measured on 60-degree gloss meter per ASTM D 523:
 - 1. AWI Finish System 9: UV Curable, Acrylated Epoxy, Polyester or Urethane.
 - 2. Staining: As selected by Architect.
 - 3. Wash Coat for Stained Finish: Apply a vinyl wash coat to woodwork made from closed-grain wood before staining and finishing.
 - 4. Open Finish for Open-Grain Woods: Do not apply filler to open-grain woods.
 - 5. Sheen: Satin.

2.12 FIELD FINISHING

- A. Field paint MDF side of sliding whiteboard doors in the field before installing into frames. Refer to Division 09 Section "Painting" for specifications.

PART 3 - EXECUTION

3.1 PREPARATION

- A. Condition woodwork to average prevailing humidity conditions in installation areas before installation.
- B. Before installing architectural woodwork, examine shop-fabricated work for completion and complete work as required, including removal of packing and backpriming.

3.2 INSTALLATION

- A. Quality Standard: Install woodwork to comply with AWI Sections cited for fabrication and in the same grade, as specified in Part 2 of this Section for type of woodwork involved
- B. Install woodwork level, plumb, true, and straight. Shim as required with concealed shims. Install level and plumb (including tops) to a tolerance of 1/8 inch in 96 inches (3 mm in 2400 mm).
- C. Scribe and cut woodwork to fit adjoining work, and refinish cut surfaces and repair damaged finish at cuts.
- D. Anchor woodwork to anchors or blocking built in or directly attached to substrates. Secure with countersunk, concealed fasteners and blind nailing as required for complete installation. Use fine finishing nails or finishing screws for exposed fastening, countersunk and filled flush with woodwork and matching final finish if transparent finish is indicated.
- E. Wood Trim: Install with minimum number of joints possible, using full-length pieces (from maximum length of lumber available) to greatest extent possible. Do not use pieces less than 36 inches (900 mm) long, except where shorter single-length pieces are necessary.
 - 1. Fill gaps, if any, between top of base and wall with plastic wood filler, sand smooth, and finish same as wood base, if finished.
 - 2. Install trim with no more variation from a straight line than 1/8 inch in 96 inches (3 mm in 2400 mm).
- F. Cabinets: Install without distortion so doors and drawers fit openings properly and are accurately aligned. Adjust hardware to center doors and drawers in openings and to provide unencumbered operation. Complete installation of hardware and accessory items as indicated.
 - 1. Install cabinets with no more than 1/8 inch in 96-inch (3 mm in 2400-mm) sag, bow, or other variation from a straight line.
 - 2. Maintain veneer sequence matching of cabinets with transparent finish.
 - 3. Fasten wall cabinets through back, near top and bottom, at ends and not more than 16 inches (400 mm) o.c. with No. 10 wafer-head sheet metal screws through metal backing or metal framing behind wall finish

- G. Countertops: Anchor securely by screwing through corner blocks of base cabinets or other supports into underside of countertop.
 - 1. Install countertops with no more than 1/8 inch in 96-inch (3 mm in 2400-mm) sag, bow, or other variation from a straight line.
 - 2. Secure backsplashes to tops with concealed metal brackets at 16 inches (400 mm) o.c.
 - 3. Caulk space between backsplash and wall with sealant specified in Division 07 Section "Joint Sealants."

- H. Complete the finishing work specified in this Section to extent not completed at shop or before installation of woodwork. Fill nail holes with matching filler where exposed. Apply specified finish coats, including stains and paste fillers if any, to exposed surfaces where only sealer/prime coats were applied in shop.

3.3 ADJUSTING AND CLEANING

- A. Repair damaged and defective woodwork, where possible, to eliminate functional and visual defects; where not possible to repair, replace woodwork. Adjust joinery for uniform appearance.

- B. Clean, lubricate, and adjust hardware.

- C. Clean woodwork on exposed and semiexposed surfaces. Touch up shop-applied finishes to restore damaged or soiled areas.

END OF SECTION 064020

SECTION 066116 - SOLID SURFACE MATERIAL FABRICATIONS

PART 1 - GENERAL

1.1 SUMMARY

- A. This Section includes solid surface material fabricated into the following:
 - 1. Solid surface material countertops.
 - 2. Solid surface material sills.
 - 3. Solid surface benches.
- B. Related Sections include the following:
 - 1. Blocking and grounds, including supports for solid surface material countertops, is specified in Division 06 Section "Miscellaneous Carpentry".
 - 2. Sealants are specified in Division 07 Section "Sealants."

1.2 ACTION SUBMITTALS

- A. Shop Drawings: Indicate dimensions, component sizes, fabrication details, attachment provisions, cutouts for insertion of accessories, and coordination requirements with adjacent work.
- B. Samples: Submit minimum 6" x 6" samples of selected colors and patterns. Where color is not specified, provide full range of manufacturer's available color samples for selection by Architect.
- C. Product Data: Indicate product description, fabrication information, and compliance with specified performance requirements.

1.3 INFORMATIONAL SUBMITTALS

- A. Maintenance Data: Submit manufacturer's care and maintenance data, including repair and cleaning instructions. Include in project closeout documents.
- B. Fabricator's Certificate: Submit certificate from manufacturer stating that fabricator is certified by manufacturer for this work.

1.4 QUALITY ASSURANCE

- A. Fabricator Qualifications: Firm experienced and licensed by manufacturer for production of solid surface fabrications similar to that indicated for this Project and with a record of successful in-service performance, as well as sufficient production capacity to produce required units without delaying the Work.

- B. Fire-Test-Response Characteristics: Provide materials with surface-burning characteristics as indicated below, as determined by testing identical products per ASTM E 84, by a testing and inspecting agency acceptable to authorities having jurisdiction.
 - 1. Flame Spread: 25 or less.
 - 2. Smoke Developed: 450 or less

1.5 JOB CONDITIONS

- A. Do not deliver components to project site until areas are ready for installation. Store indoors.
- B. Handle materials to prevent damage to finished surfaces. Provide protective coverings to prevent physical damage or staining following installation for duration of project.
- C. Field Measurements: Take field measurements prior to preparation of shop drawings and fabrication, where possible, to ensure proper fitting of work. Allow for adjustments where taking of field measurements before fabrication might delay work.
- D. Coordination: Furnish inserts and anchorages which must be built into other work. Coordinate delivery with other work to avoid delay.

1.6 WARRANTY

- A. General: The special warranty specified in this Article shall not deprive Owner of other rights Owner may have under other provisions of the Contract Documents and shall be in addition to, and run concurrent with, other warranties made by Contractor under requirements of the Contract Documents.
- B. Manufacturer's Warranty. The manufacturer warrants to the original purchaser for commercial use that the manufacturer will at its option repair or replace, without charge, such product if it fails due to a manufacturing defect during the first 10 years after initial installation.

PART 2 - PRODUCTS

2.1 MANUFACTURERS

- A. Basis of Design Manufacturers: Provide Basis of Design Products or equal product of one of the following:
 - 1. AristechAcrylics, LLC.
 - 2. DuPont Polymers
 - 3. Formica

2.2 MATERIALS

- A. General: Provide materials which have been selected for surface flatness and smoothness. Exposed surfaces which exhibit pitting, seam marks, roller marks, stains, discolorations, telegraphing of core material, or other imperfections on finished units are not acceptable.

- B. Solid Surface Material: Homogeneous solid sheets of filled plastic resin complying with ICPA SS-1.
 - 1. Thickness: 12 mm (1/2").
 - 2. Color(s) and Pattern(s):
 - a. Countertops:
 - 1) Health Suite: Wilsonart "Yukon Riverstone" 9196
 - 2) Faculty Room: Wilsonart "Chilled Earth" 9228
 - 3) Learning Commons Circulation Desk: Corian "Antarctica"
 - 4) Makerspace, Art: Corian "Dove"
 - 5) Security and Health Care Transaction Window: Wilsonart "Silver Smoke" 9226SS

 - b. Corridor Nook Benches: Corian "Natural Grey".
 - c. Sills: Corian "Deep Titanium"
 - 3. Finish: Semigloss.
 - 4. Basis of Design Products: Corian Solid Surface by DuPont Polymers, and Wilsonart Solid Surface by Wilsonart Engineered Surfaces, LLC, or equal.

2.3 MISCELLANEOUS MATERIALS

- A. Joint Adhesive: Manufacturer's standard two-part adhesive kit to create inconspicuous, non-porous joints with chemical bonding.

- B. Installation Adhesive: Product recommended by fabricator for each substrate for secure anchorage.

2.4 FABRICATION

- A. General: All fabrications shall be made using solid surface material. Fabrications shall be adhesively jointed with no exposed seams and having edge details as indicated on drawings. No exposed fasteners shall be allowed.

- B. Factory fabricate components into single unit to sizes and shapes indicated, in accordance with approved shop drawings.

- C. Form joints between components using manufacturer's standard joint adhesive without conspicuous joints.

- D. Provide factory cutouts for bowls, plumbing fittings and accessories as indicated on the drawings.

- E. Cut and finish component edges with clean, sharp returns. Route radii and contours to template. Repair or reject defective and inaccurate work.
- F. Countertops and Sills: Fabricate tops and sills in one piece. Comply with solid surfacing material manufacturer's recommendations for adhesives, sealers, fabrication, and finishing. Provide countertops with backsplash, endsplashes, aprons and nosings as shown.
 - 1. Total countertop and sill thickness shall be as indicated on the Drawings or if not indicated, 1-1/2" thick. Provide built-up fabrication as required to obtain required total thickness.
 - 2. Countertop Edges: Built-up, 1-1/2" thick, with eased edge.
 - 3. Provide waterfall edge at all sills.
- G. Allowable Tolerances
 - 1. Variation in component size: $\pm 1/8"$.
 - 2. Location of openings: $\pm 1/8"$ from indicated location.

PART 3 - EXECUTION

3.1 INSPECTION

- A. Examine surface to receive work and conditions under which work will be installed. Do not proceed with work until all unsatisfactory conditions are corrected.

3.2 INSTALLATION

- A. Install components plumb and level, scribed to adjacent finishes, in accordance with approved shop drawings and product installation data.
- B. Form field joints using manufacturer's recommended adhesive, with joints inconspicuous in finished work. Keep components and hands clean when making joints.

3.3 ADJUST AND CLEAN

- A. Clean exposed surfaces using materials and methods recommended by manufacturer, and provide protection as necessary to prevent damage during remainder of construction period. Repair work or replace damaged work that cannot be repaired as required.
- B. Keep components and hands clean during installation. Remove adhesives, sealants, and other stains. Replace stained components.

END OF SECTION 066116

The following additions, substitutions, or clarifications are extracted from the (5) Bid Addenda issued with this project during bidding. This insert is intended to summarize addendum information relevant to this specification section. See Bid Addenda issued by the City of Yonkers for complete contract document changes.

Bid Addendum No. 2:

At 2.4.H, add “and at membrane penetrations” after “construction joints.”

Add 3.4.C.2 as follows: “2. Seal penetrations through sheet waterproofing to provide watertight seal with detail tape patches or wraps, waterstops and a liquid-membrane troweling per manufacturer’s directions.”

In 3.5.D, add “, waterstops” after “wraps” and add “per manufacturer’s directions” to the end of the sentence.

SECTION 071326 – SELF-ADHERING SHEET WATERPROOFING

PART 1 - GENERAL

1.1 SUMMARY

- A. Types of sheet waterproofing specified in this Section include the following:
1. Adhesive-coated HDPE sheet waterproofing for below grade applications at elevator pit floors and under Classroom Building basement slabs on grade and turned up at edges.
 2. Rubberized asphalt sheet waterproofing for below grade applications at elevator pit walls, basement walls and all below-grade walls at occupied spaces.
 3. Drainage protection board for vertical applications.
- B. Related Sections Include the Following:
1. Division 07 Section "Thermal Insulation" for below-grade rigid insulation installed with waterproofing.

1.2 PREINSTALLATION MEETINGS

- A. Preinstallation Conference: Conduct conference at Project site in compliance with the following:
1. Before installing waterproofing, meet with Owner, Architect, consultants, independent testing agency, waterproofing manufacturer, and other concerned entities.
 2. Review requirements for waterproofing, including surface preparation specified under other Sections, substrate condition and pretreatment, minimum curing period, forecasted weather conditions, special details and sheet flashings, installation procedures, inspection and testing procedures, and protection and repairs.
 3. Notify participants at least 7 days before conference.

1.3 ACTION SUBMITTALS

- A. Product Data for each type of waterproofing specified, including manufacturer's written instructions for evaluating, preparing, and treating substrate, technical data, and tested physical and performance properties.
1. Certification by waterproofing materials manufacturer that products supplied comply with local VOC regulations.
- B. Shop Drawings showing locations and extent of waterproofing, including details for substrate joints and cracks, sheet flashings, penetrations, tie-ins with adjoining construction, and other termination conditions.

- C. Samples, 3-by-6-inch (75-by-150-mm) minimum size, of each waterproofing and associated materials required for Project.

1.4 INFORMATIONAL SUBMITTALS

- A. Qualification Data: For Installer. Submit certificates signed by manufacturer stating that installers comply with requirements under the "Quality Assurance" Article
- B. Sample Warranties: For special warranties.

1.5 QUALITY ASSURANCE

- A. Manufacturer's Qualifications: Obtain primary waterproofing materials of each type required from a single manufacturer that has been producing such materials for a minimum of ten years. Provide secondary materials only as recommended by manufacturer of primary materials.
- B. Installer: A firm with not less than five waterproofing projects similar to requirements (including size and scope) for this Project with satisfactory in-service performance and which is acceptable to primary waterproofing materials manufacturer.
- C. Single-Source Responsibility: Obtain waterproofing materials from a single manufacturer regularly engaged in manufacturing waterproofing.

1.6 DELIVERY, STORAGE, AND HANDLING

- A. Deliver materials to Project site in original packages with seals unbroken, labeled with manufacturer's name, product, date of manufacture, and directions for storage.
- B. Store materials in their original undamaged packages in a clean, dry, protected location and within temperature range required by waterproofing manufacturer. Protect stored materials from direct sunlight.

1.7 PROJECT CONDITIONS

- A. Substrate: Proceed with work after substrate construction, openings, and penetrating work have been completed and areas are free of standing or running water, ice, and frost. Verify that concrete is dry, smooth, and free from sharp or ragged out-angles, honeycombing, rock pockets, depressions, and projections.
- B. Environmental Conditions: Apply waterproofing within range of ambient and substrate temperatures recommended by waterproofing manufacturer. Do not apply waterproofing to a damp or wet substrate.
 - 1. Do not apply waterproofing in snow, rain, fog, or mist.
 - 2. Proceed with waterproofing and associated work only when existing and forecasted weather conditions will permit work to be performed in accordance with manufacturers' recommendations and warranty requirements.

- C. Do not install waterproofing where it will be exposed to rain, sleet or snow for any duration prior to the installation of toppings or other adjacent materials.

1.8 WARRANTY

- A. The warranty shall not deprive the Owner of other rights the Owner may have under other provisions of the Contract Documents and will be in addition to and run concurrent with other warranties made by the Contractor under requirements of the Contract Documents.
- B. Special Warranty: Submit a written warranty executed by the manufacturer, agreeing to repair or replace sheet membrane waterproofing that fails in materials or workmanship within specified warranty period.
 - 1. Warranty Period: Five years from date of Substantial Completion.

PART 2 - PRODUCTS

2.1 MANUFACTURERS

- A. Products: Provide waterproofing system with all auxiliary components as required and recommended by manufacturer for applications indicated; manufactured by one of the following, or equal:
 - 1. Carlisle Coatings and Waterproofing
 - 2. GCP Applied Technologies, Inc.
 - 3. Tamko Roofing Products, Inc.

2.2 RUBBERIZED ASPHALT SHEET WATERPROOFING

- A. Self-adhesive, cold-applied composite sheet consisting of a thickness of 1.4 mm (0.056 in.) of rubberized asphalt and 0.1 mm (0.004 in.) of cross-laminated, high density polyethylene film, formed into uniform flexible sheets of not less than 1.5 mm (0.060 inch) thick, complying with the following:
 - 1. Tensile Strength: 325 psi minimum; ASTM D 412.
 - 2. Ultimate Elongation: 300 percent minimum; ASTM D 412.
 - 3. Puncture Resistance: 50 lbs minimum; ASTM E 154.
 - 4. Hydrostatic Head Resistance: 230 feet minimum; ASTM D 5385.
 - 5. Water Absorption: Not more than 0.1 percent weight gain after 48 hours' immersion at 70 deg F (21 deg C); ASTM D 570.
 - 6. Permeance: 0.1 perm maximum; ASTM E 96, Section 12 – Water Method.
- B. Basis of Design Product: Provide Bituthene System 3000 by GCP Applied Technologies, Inc. or one of the following:
 - 1. CCW MiraDRI 860/861, Carlisle Coatings and Waterproofing.
 - 2. TW-60; Tamko Roofing Products, Inc.

2.3 ADHESIVE-COATED HDPE SHEET WATERPROOFING

- A. Adhesive-Coated HDPE Sheet for Horizontal Applications: 46-mil- (1.2-mm-) thick, uniform, flexible sheets consisting of 30-mil- (0.76-mm-) thick, HDPE sheet coated with a pressure-sensitive rubber adhesive, a protective adhesive coating, a detackifying surface treatment, an uncoated self-adhering side lap strip, and a release liner with the following physical properties:
1. Tensile Strength, Film: 4000 psi (27.6 MPa) minimum; ASTM D 412.
 2. Low-Temperature Flexibility: Pass at minus 10 deg F (minus 23 deg C); ASTM D 1970.
 3. Peel Adhesion to Concrete: 5 lbf/in. (875 N/m); ASTM D 903, modified.
 4. Lap Adhesion: 2.5 lbf/in. (440 N/m); ASTM D 1876, modified.
 5. Hydrostatic-Head Resistance: 231 feet (70 m); ASTM D 5385, modified.
 6. Vapor Permeance: 0.01 perms (0.6 ng/Pa x s x sq. m); ASTM E 96, Water Method.
 7. Water Absorption: 0.5 percent; ASTM D 570.
- B. Basis of Design Product: Provide Preprufe 300R manufactured by GCP Applied Technologies, Inc. or one of the following:
1. Underseal Underslab Membrane; Polyguard Products, Inc.
 2. Or equivalent.

2.4 AUXILIARY MATERIALS

- A. General: Furnish auxiliary materials recommended by waterproofing manufacturer for intended use and compatible with sheet waterproofing.
- B. Adhesives and Joint Tape: Provide types of adhesive compound and tapes recommended by waterproofing sheet manufacturer for bonding to substrate (if required), for waterproofing seams in membrane, and for waterproofing joints between membrane and flashings, adjoining surfaces, and projections through membrane.
1. Detail Tape for HDPE Membrane: Two-sided, pressure-sensitive, self-adhering reinforced tape, 4-1/2 inches (114 mm) wide, with a tack-free protective adhesive coating on one side and release film on self-adhering side.
- C. Primers: Provide type of concrete primer recommended by manufacturer of sheet waterproofing material for applications required.
- D. Flashing Materials: Except as otherwise indicated, provide types of flexible sheet material for flashing as recommended by waterproofing sheet manufacturer.
- E. Trowelable Liquid Membrane: Two component, cold-applied trowel grade waterproofing material used to flash corners, form fillets and detail hard-to-reach areas. Type recommended by membrane manufacturer, compatible with membrane.

- F. Metal Termination Bars: Aluminum bars, approximately 1 by 1/8 inch (25 by 3 mm) thick, predrilled at 9-inch (229-mm) centers.
- G. Rigid Insulation: Specified in Division 07 Section "Thermal Insulation".
- H. Waterstops: Hydrophilic waterstop for non-moving concrete construction joints.
 - 1. Basis of Design Product: Adcor by GCP Applied Technologies or equal.

2.5 MOLDED-SHEET DRAINAGE PANELS

- A. Nonwoven-Geotextile-Faced, Molded-Sheet Drainage Panel: Manufactured composite drainage panels, 3-dimensional, nonbiodegradable, manufactured with a permeable geotextile bonded to molded-plastic-sheet drainage core and designed to effectively convey water.
 - 1. Vertical Application: Provide product with properties suitable for use vertically:
 - a. Thickness: 0.40 inches (10.16 mm) min.
 - b. Compressive Strength per ASTM D 1621: 15,000 pounds per sq. ft..
 - c. Filter Fabric Tensile Strength per ASTM D 4632: 100 pounds min.
 - d. Filter Fabric Puncture Resistance per ASTM D 4833: 65 pounds.
 - e. Filter Fabric Apparent Opening Size per ASTM D 4751: Sieve size 70 max.
 - 1) Basis of Design Product: Provide Hydroduct 220 by GCP Applied Technologies, Inc. or one of the following:
 - 2) CCW MiraDRAIN 6000/6200, Carlisle Coatings and Waterproofing.
 - 3) Hydrodrain 400, American Hydrotech, Inc.

PART 3 - EXECUTION

3.1 EXAMINATION

- A. Examine substrates, areas, and conditions under which waterproofing systems will be applied, with Installer present, for compliance with requirements. Do not proceed with installation until unsatisfactory conditions have been corrected.
 - 1. Do not proceed with installation until after minimum concrete curing period recommended by waterproofing manufacturer.
 - 2. Verify substrate is visibly dry and free of moisture. Test for capillary moisture by plastic sheet method according to ASTM D 4263.
 - 3. Verify that compacted subgrade is dry, smooth, and sound; and ready to receive adhesive-coated HDPE sheet.
 - 4. Notify Architect in writing of anticipated problems using waterproofing over substrate.

3.2 SURFACE PREPARATION

- A. General: Comply with manufacturer's instructions for preparing surface.

- B. Clean, prepare, and treat substrate according to manufacturer's written instructions. Provide clean, dust-free, and dry substrate for waterproofing application.
- C. Mask off adjoining surfaces not receiving waterproofing to prevent spillage affecting other construction.
- D. Remove grease, oil, bitumen, form release agents, paints, and other penetrating contaminants from concrete.
- E. Remove fins, ridges, mortar, and other projections and fill honeycomb, aggregate pockets, holes, and other voids.
- F. Prepare, fill, prime, and treat joints and cracks in substrate in accordance with manufacturer's directions. Remove dust and dirt from joints and cracks according to ASTM D 4258.
- G. Corners: Prepare, prime, and treat inside and outside corners according to ASTM D 6135 and manufacturer's directions.
- H. Prepare, treat, and seal vertical and horizontal surfaces at terminations and penetrations through waterproofing and at drains and protrusions according to ASTM D 6135.
- I. Apply primer to substrate surfaces at rate recommended by manufacturer of primary waterproofing materials. Prime only area that will be covered by waterproofing membrane in same working day. Reprime areas not covered by waterproofing membrane within 24 hours.

3.3 INSTALLATION, GENERAL

- A. Comply with manufacturer's instructions for handling and installing sheet waterproofing materials.
 - 1. Apply rubberized asphalt membrane waterproofing to vertical surfaces of elevator pit, foundation walls, and elsewhere as indicated on drawings.
 - 2. Apply adhesive coated HDPE membrane waterproofing under slab at elevator pit, for all blind pours, at basement floor slabs and elsewhere as indicated on drawings.
- B. Coordinate installing waterproofing materials with associated work to provide complete system complying with combined recommendations by manufacturers and installers involved in Work. Schedule installation to minimize exposure of sheet waterproofing materials.

3.4 RUBBERIZED ASPHALT SHEET WATERPROOFING APPLICATION

- A. Accurately align sheets and maintain uniform side and end laps of minimum dimensions required. Stagger end laps.

- B. Apply bonding adhesive to substrate at required rate and allow to partially dry.
- C. Apply waterproofing sheet to vertical surfaces in shingled fashion, starting at the low point and working toward high point of wall. Overlap all side seams a minimum of 2-1/2 inches and end laps a minimum of 5 inches. Roll all membrane with hand roller. Firmly press edges of membrane to surfaces to provide watertight seal. Apply bead of mastic to all terminations.
 - 1. Provide a fillet of liquid membrane at all inside corners covered with sheet waterproofing prior to flashing with sheet waterproofing.
- D. Seal projections through membrane and seal seams. Bond to vertical surfaces and also, where shown or recommended by manufacturer, bond to horizontal surfaces.
- E. Spread sealant or mastic bed over deck drain flange at deck drains and securely seal waterproofing sheet in place with clamping ring.
- F. Apply continuous sheets over sheet strips bridging substrate cracks, construction, and contraction joints
- G. For vertical and sloped-wall membrane, finish in termination bar; otherwise finish under flashing or under masonry in joint. Seal exposed edges with mastic or sealant.
- H. Repair tears, voids, and lapped seams in waterproofing not complying with requirements. Slit and flatten fishmouths and blisters. Patch with sheets extending 6 inches (150 mm) beyond repaired areas in all directions.
- I. Correct deficiencies in or remove sheet waterproofing that does not comply with requirements, repair substrates, reapply waterproofing, and repair sheet flashings.
- J. Immediately install drainage panels with butted joints over waterproofing membrane

3.5 ADHESIVE-COATED HDPE SHEET WATERPROOFING APPLICATION

- A. Install adhesive-coated HDPE sheets according to manufacturer's written instructions.
- B. Horizontal Applications: Install adhesive-coated HDPE sheet with HDPE face against substrate. Accurately align sheets and maintain uniform 3-inch- (75-mm-) minimum lap widths and end laps. Overlap and seal seams. Overlap, stagger, and seal end laps with detail tape to ensure watertight installation.
- C. Corners: Seal lapped terminations and cut edges of sheet waterproofing at inside and outside corners with detail tape.
- D. Seal penetrations through sheet waterproofing to provide watertight seal with detail tape patches or wraps and a liquid-membrane troweling.
- E. Install sheet waterproofing and auxiliary materials to produce a continuous watertight tie into adjacent waterproofing.

- F. Repair tears, voids, and lapped seams in waterproofing not complying with requirements. Tape perimeter of damaged or nonconforming area extending 6 inches (150 mm) beyond repaired areas in all directions. Apply a patch of sheet waterproofing and firmly secure with detail tape.
- G. Correct deficiencies in or remove waterproofing that does not comply with requirements; repair substrates, reapply waterproofing, and repair sheet flashings.

3.6 MOLDED-SHEET DRAINAGE PANEL INSTALLATION

- A. Place and secure molded-sheet drainage panels with geotextile facing away from wall surface, according to manufacturer's written instructions over installed waterproofing membrane. Use adhesives that do not penetrate waterproofing. Lap edges and ends of geotextile to maintain continuity. Protect installed molded-sheet drainage panels by installing protection course of rigid insulation over drainage panel, as indicated on Drawings.

3.7 INSULATION INSTALLATION

- A. Install single layer of board insulation over installed drainage panel as indicated on Drawings. Cut and fit to within 3/4 inch (19 mm) of projections and penetrations
- B. On vertical surfaces, set insulation units in adhesive or tape applied according to manufacturer's written instructions.
- C. Protect during subsequent construction operations.

3.8 PROTECTING AND CLEANING

- A. Protect waterproofing from damage and wear during application and remainder of construction period according to manufacturer's written instructions. Do not allow traffic of any type on unprotected membrane.
- B. Protect installed insulation from damage due to ultraviolet light exposure, physical abuse, and other causes. Provide temporary coverings where insulation will be subject to abuse and cannot be concealed and protected by permanent construction immediately after installation.
- C. Clean spillage and soiling from adjacent construction using cleaning agents and procedures recommended by manufacturer of affected construction.

END OF SECTION 071326

SECTION 072100 - THERMAL INSULATION

PART 1 - GENERAL

1.1 SUMMARY

A. Section Includes:

1. Foam-plastic board insulation.
2. Mineral-wool board insulation.
3. Mineral-wool blanket insulation.
4. Insulation jacketing system for ducts on roof.

B. Related Sections:

1. Section 042000 "Unit Masonry" for insulation installed in cavity walls and masonry cells.
2. Section 075323 "EPDM Roofing" for insulation specified as part of roofing construction.
3. Section 078446 "Joint Firestopping" for insulation installed as part of a perimeter joint firestopping system.
4. Section 092900 "Gypsum Board" for installation of acoustical blankets in metal-framed assemblies.

1.2 ACTION SUBMITTALS

- ##### A. Product Data:
- For each type of product indicated.

1.3 INFORMATIONAL SUBMITTALS

- ##### A. Product Test Reports:
- Based on evaluation of comprehensive tests performed by a qualified testing agency, for each product.
- ##### B. Research/Evaluation Reports:
- For foam-plastic insulation, from ICC-ES.

1.4 QUALITY ASSURANCE

- ##### A. Surface-Burning Characteristics:
- As determined by testing identical products according to ASTM E 84 by a qualified testing agency. Identify products with appropriate markings of applicable testing agency.
- ##### B. Vertical and Lateral Fire Propagation Test Characteristics:
- The exterior wall assembly of the School Building is required to comply with NFPA 285 "Standard Method of Test for the Evaluation of Flammability Characteristics of Exterior Nonload-bearing Wall Assemblies Containing Combustible Components." The base wall, stud cavity insulation, wall sheathing, air barrier, continuous wall rigid insulation and exterior cladding are components that are required to be to be evaluated as part of this specific

assembly test. Insulation shall be part of an assembly that has passed NFPA 285 testing.

1.5 DELIVERY, STORAGE, AND HANDLING

- A. Protect insulation materials from physical damage and from deterioration due to moisture, soiling, and other sources. Store inside and in a dry location. Comply with manufacturer's written instructions for handling, storing, and protecting during installation.
- B. Protect foam-plastic board insulation as follows:
 - 1. Do not expose to sunlight except to necessary extent for period of installation and concealment.
 - 2. Protect against ignition at all times. Do not deliver foam-plastic board materials to Project site before installation time.
 - 3. Quickly complete installation and concealment of foam-plastic board insulation in each area of construction.

PART 2 - PRODUCTS

2.1 FOAM-PLASTIC BOARD INSULATION

- A. Extruded-Polystyrene Board Insulation: ASTM C 578, of type and minimum compressive strength indicated below, with maximum flame-spread and smoke-developed indexes of 75 and 450, respectively, per ASTM E 84.
 - 1. Basis of Design Product: Styrofoam Brand SM Insulation by DuPont (formerly Dow) or equal products by one of the following:
 - a. DiversiFoam Products.
 - b. Owens Corning.
 - 2. Type IV, 25 psi (173 kPa).
 - 3. Thickness: As indicated on Drawings for each application.
 - 4. Edges: Square edge or shiplap edge boards, manufacturer's standard for thicknesses required.
 - 5. Applications: Below grade applications.
- B. Polyisocyanurate Board Insulation: ASTM C 1289, Type I, Class 2, with maximum flame-spread and smoke-developed indexes of 75 and 450, respectively, per ASTM E 84.
 - 1. Basis of Design Product: Provide Thermax (ci) Exterior Insulation by DuPont (formerly Dow) or equal products by one of the following.
 - a. Atlas Roofing Corporation.
 - b. Rmax, Inc.
 - 2. Thickness: As indicated on Drawings for each application.
 - 3. Facing: Foil faced both sides.

4. Edges: Square edge or shiplap edge boards, manufacturer's standard for thicknesses required.
 5. Application: Exterior wall sheathing.
 6. Fire Propagation Characteristics: Passes NFPA 285 testing as part of an approved assembly.
- C. Adhesive for Bonding Insulation: Product with demonstrated capability to bond insulation securely to substrates without damaging insulation and substrates.
1. VOC Limits: Provide adhesives with VOC content not more than 50 g/L when calculated according to 40 CFR 59, Subpart D (EPA method 24).
- ## 2.2 MINERAL-WOOL BOARD INSULATION (SEMI-RIGID)
- A. Manufacturers: Subject to compliance with requirements, provide products by one of the following or equal:
1. Industrial Insulation Group LLC; Div. of Johns Manville
 2. Isolatek International.
 3. Owens Corning.
 4. Roxul Inc.
 5. Thermafiber.
- B. Unfaced, Mineral-Wool Board Insulation: ASTM C 612; with maximum flame-spread and smoke-developed indexes of 15 and zero, respectively, per ASTM E 84; passing ASTM E 136 for combustion characteristics.
1. Nominal density of 4 lb/cu. ft. (64 kg/cu. m), Types IA and IB, thermal resistivity of 4 deg F x h x sq. ft./Btu x in. at 75 deg F (27.7 K x m/W at 24 deg C).
 2. Fiber Color: Regular color, unless otherwise indicated.
 3. Thickness: As indicated on Drawings for each application
 4. Application: Provide for perimeter wall insulation at spandrels in curtainwall framing, at steel beams, roof areas, and other areas indicated.
 - a. Refer to Section 078446 "Joint Firestopping" for mineral wool insulation provided as part of a joint firestopping assembly/system.
- C. Foil-Faced, Mineral-Wool Board Insulation: ASTM C 612; faced on one side with foil-scrim or foil-scrim-polyethylene vapor retarder; with maximum flame-spread and smoke-developed indexes of 25 and 5, respectively, per ASTM E 84.
1. Nominal density of 4 lb/cu. ft. (64 kg/cu. m), Types IA and IB, thermal resistivity of 4 deg F x h x sq. ft./Btu x in. at 75 deg F (27.7 K x m/W at 24 deg C).
 - a. Application: Provide for perimeter wall insulation at fin tube cabinet enclosures' interior surfaces.
 2. Fiber Color: Regular color, unless otherwise indicated.
 3. Thickness: As indicated on Drawings for each application

2.3 MINERAL-WOOL BLANKET INSULATION

- A. Unfaced, Mineral-Wool Blanket Insulation: ASTM C 665, Type 1 (blankets without membrane facing); consisting of fibers; with maximum flame-spread and smoke-developed indexes of 25 and 50, respectively, per ASTM E 84; passing ASTM E 136 for combustion characteristics.
1. Products: Subject to compliance with requirements, provide one of the following:
 - a. ROXUL; Comfortbatt
 - b. Thermafiber; UltraBatt
 2. Thickness: As indicated on Drawings for each application
 3. Application: Provide for concealed building insulation in ceiling/roof assemblies, parapets, exterior stud walls, and elsewhere indicated on drawings.

2.4 INSULATION JACKETING SYSTEM FOR DUCTS ON ROOF

- A. System consisting of factory faced insulation board and multi-ply laminate insulation wrap which acts as a vapor barrier, suitable for installations in temperature range at building locale; provide 3M VentureClad Insulation Jacketing System or equal.

2.5 INSULATION FASTENERS

- A. Adhesively Attached, Spindle-Type Anchors: Plate welded to projecting spindle; capable of holding insulation of specified thickness securely in position indicated with self-locking washer in place.
1. Products: Subject to compliance with requirements, provide one of the following or equal:
 - a. AGM Industries, Inc.; Series T TACTOO Insul-Hangers.
 - b. Eckel Industries of Canada; Stic-Klip Type N Fasteners
 - c. Gemco; Spindle Type.
 2. Plate: Perforated, galvanized carbon-steel sheet, 0.030 inch (0.762 mm) thick by 2 inches (50 mm) square.
 3. Spindle: Copper-coated, low-carbon steel; fully annealed; 0.105 inch (2.67 mm) in diameter; length to suit depth of insulation indicated.
- B. Adhesively Attached, Angle-Shaped, Spindle-Type Anchors: Angle welded to projecting spindle; capable of holding insulation of specified thickness securely in position indicated with self-locking washer in place.
1. Products: Subject to compliance with requirements, provide one of the following or equal:
 - a. Gemco; 90-Degree Insulation Hangers.
 2. Angle: Formed from 0.030-inch- (0.762-mm-) thick, perforated, galvanized carbon-steel sheet with each leg 2 inches (50 mm) square.

3. Spindle: Copper-coated, low-carbon steel; fully annealed; 0.105 inch (2.67 mm) in diameter; length to suit depth of insulation indicated.
- C. Insulation-Retaining Washers: Self-locking washers formed from 0.016-inch- (0.41-mm-) thick galvanized-steel sheet, with beveled edge for increased stiffness, sized as required to hold insulation securely in place, but not less than 1-1/2 inches (38 mm) square or in diameter.
1. Products: Subject to compliance with requirements, provide one of the following or equal:
 - a. AGM Industries, Inc.; RC150 or SC150.
 - b. Gemco; Dome-Cap, R-150 or S-150.
 2. Protect ends with capped self-locking washers incorporating a spring steel insert to ensure permanent retention of cap in the following locations:
 - a. Crawl spaces.
 - b. Ceiling plenums.
 - c. Attic spaces.
 - d. Where indicated.
- D. Gas-Actuated Insulation Fasteners: Non-metallic insulation fastener assembly consisting of a plate or washer component formed from HDPE and a nail or pin component fabricated from zinc coated carbon steel pre-mounted in the plastic assembly, designed to be installed using a proprietary gas-actuated tool.
1. Products: Subject to compliance with requirements, provide one of the following or equal:
 - a. X-IE-G Insulation Fastening System by Hilti
 - b. Ramset-I-F System by ITW Commercial Construction

PART 3 - EXECUTION

3.1 PREPARATION

- A. Clean substrates of substances that are harmful to insulation or vapor retarders, including removing projections capable of puncturing vapor retarders, or that interfere with insulation attachment.

3.2 INSTALLATION, GENERAL

- A. Comply with insulation manufacturer's written instructions applicable to products and applications indicated.
- B. Install insulation that is undamaged, dry, and unsoiled and that has not been left exposed to ice, rain, or snow at any time.

- C. Extend insulation to envelop entire area to be insulated. Cut and fit tightly around obstructions and fill voids with insulation. Remove projections that interfere with placement.
- D. Provide sizes to fit applications indicated and selected from manufacturer's standard thicknesses, widths, and lengths. Apply single layer of insulation units to produce thickness indicated unless multiple layers are otherwise shown or required to make up total thickness.

3.3 INSTALLATION OF BELOW-GRADE INSULATION

- A. On vertical surfaces, set insulation units using manufacturer's recommended adhesive according to manufacturer's written instructions. Extend insulation to dimension below exterior grade line as indicated.
 - 1. Where below grade insulation is installed over drainage protection board and installed waterproofing membrane, install boards vertically, loose laid.
- B. On horizontal surfaces, loosely lay insulation units according to manufacturer's written instructions. Stagger end joints and tightly abut insulation units.

3.4 INSTALLATION OF INSULATION FOR FRAMED AND FURRED CONSTRUCTION

- A. Apply insulation units to substrates by method indicated, complying with manufacturer's written instructions. If no specific method is indicated, bond units to substrate with adhesive or use mechanical anchorage to provide permanent placement and support of units.
- B. Foam-Plastic Board Insulation: Seal joints between units by applying adhesive, mastic, or sealant to edges of each unit to form a tight seal as units are shoved into place. Fill voids in completed installation with adhesive, mastic, or sealant as recommended by insulation manufacturer.
- C. Mineral-Wool Blanket Insulation: Install in cavities formed by framing members according to the following requirements:
 - 1. Use insulation widths and lengths that fill the cavities formed by framing members. If more than one length is required to fill the cavities, provide lengths that will produce a snug fit between ends.
 - 2. Place insulation in cavities formed by framing members to produce a friction fit between edges of insulation and adjoining framing members.
 - 3. Maintain 3-inch (76-mm) clearance of insulation around recessed lighting fixtures not rated for or protected from contact with insulation.
 - 4. For metal-framed wall cavities where cavity heights exceed 96 inches (2438 mm), support unfaced blankets mechanically and support faced blankets by taping flanges of insulation to flanges of metal studs. Install with required number of fasteners in accordance with manufacturer's recommendations.
 - 5. Vapor-Retarder-Faced Blankets: Tape joints and ruptures in vapor-retarder facings, and seal each continuous area of insulation to ensure airtight installation.

- a. Exterior Walls: Set units with facing placed toward interior of construction.
 - D. Miscellaneous Voids: Install insulation in miscellaneous voids and cavity spaces where required to prevent gaps in insulation using the following materials:
 - 1. Unfaced mineral wool insulation.
- 3.5 INSTALLATION OF INSULATION IN CEILINGS FOR SOUND ATTENUATION
- A. Where mineral-wool blankets are indicated for sound attenuation above ceilings, install blanket insulation over entire ceiling area in thicknesses indicated. Extend insulation 48 inches (1219 mm) up either side of partitions.
- 3.6 INSTALLATION OF INSULATION FOR CONCRETE SUBSTRATES
- A. Install board insulation on concrete substrates by adhesively attached, spindle-type insulation anchors as follows:
 - 1. Fasten insulation anchors to concrete substrates with insulation anchor adhesive according to anchor manufacturer's written instructions. Space anchors according to insulation manufacturer's written instructions for insulation type, thickness, and application indicated.
 - 2. Apply insulation standoffs to each spindle to create cavity width indicated between concrete substrate and insulation.
 - 3. After adhesive has dried, install board insulation by pressing insulation into position over spindles and securing it tightly in place with insulation-retaining washers, taking care not to compress insulation below indicated thickness.
 - 4. Where insulation will not be covered by other building materials, apply capped washers to tips of spindles.
 - B. Install board insulation on concrete substrates by gas-actuated fastening system in accordance with manufacturer's directions.
- 3.7 INSTALLATION OF CURTAIN-WALL INSULATION
- A. Install board insulation in curtain-wall construction where indicated on Drawings according to curtain-wall manufacturer's written instructions.
 - 1. Hold insulation in place by securing metal clips and straps or integral pockets within window frames, spaced at intervals recommended in writing by insulation manufacturer to hold insulation securely in place without touching spandrel glass. Maintain cavity width of dimension indicated between insulation and glass, but in no case less than 1 inch cavity width.
 - 2. Install insulation where it contacts perimeter fire-containment system to prevent insulation from bowing under pressure from perimeter fire-containment system; refer to Section 078446 for installation of joint firestopping system components.

3.8 PROTECTION

- A. Protect installed insulation and vapor retarders from damage due to harmful weather exposures, physical abuse, and other causes. Provide temporary coverings or enclosures where insulation is subject to abuse and cannot be concealed and protected by permanent construction immediately after installation.

END OF SECTION 072100

SECTION 072419 - WATER-DRAINAGE EXTERIOR INSULATION AND FINISH SYSTEM
(EIFS)

PART 1 - GENERAL

1.1 This Section includes the following:

1. Water-drainage exterior insulation and finish system (EIFS) applied over gypsum sheathing.

B. Related Work Specified Elsewhere:

1. Gypsum sheathing is specified in Division 06 Section "Gypsum Sheathing."

1.2 DEFINITIONS

A. Class PB EIFS: A non-load-bearing, exterior wall cladding system that consists of an insulation board attached adhesively, mechanically, or both to the substrate; an integrally reinforced base coat; and a textured protective finish coat.

B. Water-Drainage EIFS: EIFS with a means that allows water entering into an EIFS assembly to drain to the exterior.

1.3 ACTION SUBMITTALS

A. Product Data: For each component of EIFS specified.

B. Shop Drawings: Show fabrication and installation of system including plans, elevations, sections, details of components, reveals, joint locations and configurations within system and between system and construction penetrating it, termination details, and attachments to construction behind system.

C. Samples for Initial Selection: Manufacturer's color charts and small-scale samples consisting of units or sections of units showing the full range of colors, textures, and patterns available for each finish choice indicated.

1. Submit sealant manufacturer's standard bead samples consisting of strips of actual products showing the full range of colors available.

D. Samples for Verification: 24-inch- (600-mm-) square panels for each finish, color, texture, and pattern specified. Prepare samples using same tools and techniques intended for actual work.

1.4 INFORMATIONAL SUBMITTALS

A. Manufacturer Certificates: Signed by EIFS manufacturer, certifying the following:

1. EIFS complies with requirements.
2. Substrates to which EIFS is indicated to be attached are acceptable to EIFS manufacturer.
3. Accessory products installed with EIFS, including joint sealants, flashing, water-resistive barrier coatings, trim, whether or not furnished by EIFS manufacturer and whether or not specified in this Section, are acceptable to EIFS manufacturer..

B. Qualification Data: For installer.

C. Product Test Reports: Indicate compliance of proposed EIFS with physical property requirements specified in "Performance Requirements" Article based on comprehensive testing of current products by a qualified testing and inspecting agency.

D. Research/Evaluation Reports: Evidence of EIFS compliance with building code in effect for Project, from a model code organization acceptable to authorities having jurisdiction.

1.5 QUALITY ASSURANCE

A. Installer Qualifications: An installer who is certified in writing by the EIFS manufacturer as qualified to install their system using trained workers

B. Source Limitations: Obtain materials for system from one source and by a single manufacturer or by manufacturers approved by EIFS manufacturer as compatible with other system components.

1.6 DELIVERY, STORAGE, AND HANDLING

A. Deliver materials in original, unopened packages with manufacturer's labels intact and clearly identifying products.

B. Store materials inside and under cover; keep them dry and protected from the weather, direct sunlight, surface contamination, aging, corrosion, damaging temperatures, construction traffic, and other causes.

1. Stack insulation board flat and off the ground.

1.7 PROJECT CONDITIONS

A. Environmental Limitations: Do not install system when ambient outdoor air and substrate temperatures are 40 deg F (4.4 deg C) and falling unless temporary protection and heat are provided to maintain ambient temperatures above 40 deg F (4.4 deg C) during installation of wet materials and until they have dried thoroughly and become weather resistant, but for at least 24 hours after installation.

1.8 COORDINATION AND SCHEDULING

A. Coordinate installation of EIFS with related Work specified in other Sections to ensure that wall assemblies, including sheathing, flashing, trim, joint sealers, windows, and doors, are

protected against damage from the effects of weather, age, corrosion, moisture, and other causes. Do not allow water to penetrate behind EIFS.

1.9 WARRANTY

A. **Manufacturer's Special Warranty:** Manufacturer agrees to repair or replace components of EIFS-clad drainage-wall assemblies that fail in materials or workmanship within specified warranty period.

1. Failures include, but are not limited to, the following:
 - a. Bond integrity and weathertightness.
 - b. Deterioration of EIFS finishes and other EIFS materials beyond normal weathering.
2. Warranty coverage includes the following components of EIFS-clad drainage-wall assemblies:
 - a. EIFS finish, including base coats, finish coats, and reinforcing mesh.
 - b. Insulation installed as part of EIFS.
 - c. Insulation adhesive and mechanical fasteners.
 - d. EIFS accessories, including trim components and flashing.
 - e. Water-resistive barrier coatings.
 - f. EIFS drainage components.
3. Warranty Period: Ten years from date of Substantial Completion.

PART 2 - PRODUCTS

2.1 MANUFACTURERS

- A. **Basis of Design Manufacturers:** Subject to compliance with requirements, provide "Outsulation X" system by Dryvit Systems, Inc., or equal products by one of the following:
1. Synergy, a BASF Company.
 2. STO.

2.2 PERFORMANCE REQUIREMENTS

- A. **EIFS Performance:** Comply with ASTM E2568 and with the following:
1. **Weathertightness:** Resistant to uncontrolled water penetration from exterior, with a means to drain water entering EIFS to the exterior
 2. **Structural Performance of Assembly and Components:**
 - a. **Wind Loads:** Uniform pressure as indicated on Structural Drawings.
 3. **Impact Performance:** ASTM E2568; Standard impact resistance except provide Ultra High impact resistance at all lower panels within 8 ft. of ground.
 4. **Abrasion Resistance:** Sample consisting of 1-inch- (25.4-mm-) thick EIFS mounted on 1/2-inch- (12.7-mm-) thick gypsum board; cured for a minimum of 28 days; and

showing no cracking, checking, or loss of film integrity after exposure to 528 quarts (500 L) of sand when tested per ASTM D 968, Method A.

5. Mildew Resistance: Sample consisting of finish coat applied to 2-by-2-inch (50.8-by-50.8-mm) clean glass substrate; cured for 28 days; and showing no growth when tested per ASTM D 3273 and evaluated according to ASTM D3274.
6. Drainage Efficiency: 90 percent average minimum when tested according to ASTM E2273.

- B. Fire-Test-Response Characteristics: Provide system assemblies and components with the following fire-test-response characteristics as determined by testing identical products per test method indicated below by UL or another testing and inspecting agency acceptable to authorities having jurisdiction. Identify products with appropriate markings of applicable testing and inspecting agency.

1. Flame Spread of Insulation Board and Finish Coats: 25 or less when tested individually per ASTM E 84.
2. Smoke Developed of Insulation Board and Finish Coats: 450 or less when tested individually per ASTM E 84.

2.3 MATERIALS

- A. Compatibility: Provide substrates, adhesive, board insulation, reinforcing meshes, base- and finish-coat materials, air and moisture barrier, sealants, and accessories that are compatible with one another and approved for use by system manufacturer for Project.
- B. Colors, Textures, and Patterns of Finish Coat: Comply with the following requirements:
1. Provide Architect's selections from system manufacturer's full range of colors, textures, and patterns for type of finish coat indicated.
- C. Weather Barrier: System manufacturer's secondary air and weather barrier 100 percent acrylic barrier job mixed with portland cement complying with ASTM C 150, Type I designed to seal substrates from moisture penetration and to improve the bond between substrate of type indicated and adhesive used for application of insulation; "Backstop NT," or equivalent.
- D. Weather Barrier Accessories:
1. Fiberglass Mesh Tape: Open weave fiberglass mesh tape with pressure sensitive adhesive; "Grid Tape," or equivalent.
 2. Liquid-Applied Flashing: Flexible water-based polymer material; "Aquaflash Liquid" and "Aquaflash Mesh" or equivalent.
 3. Flashing and Filler: Flexible waterproof, low temperature gun applied material: "Backstop Flash and Fill" or equivalent.
- E. Waterproof Adhesive for Application of Insulation: System manufacturer's waterproof formulation designed for indicated use, compatible with substrate, and complying with the following requirements:

1. Job-mixed formulation of portland cement complying with ASTM C 150, Type I, and polymer-based adhesive; "Genesis," or equivalent.
- F. Extruded-Polystyrene Board Insulation: Rigid, closed cell high-performance polystyrene material formed by the extrusion process, and meeting ASTM C578 Type X properties.
1. R-Value = 5.0/inch
 2. Provide insulation in boards not more than 24 by 48 inches (610 by 1219 mm) and in thickness indicated but not more than 4 inches (102 mm).
 3. Provide pre-coated insulation starter boards, corners and shapes as required for complete installation.
 4. Basis of Design Product: Provide DOW XENERGY XPS by Dryvit.
- G. Reinforcing Mesh: Balanced, alkali-resistant, open-weave glass-fiber mesh treated for compatibility with other system materials, made from continuous multiend strands with retained mesh tensile strength of not less than 120 lbf/in. (21 dN/cm) per EIMA 105.01, complying with ASTM D 578 and the following requirements for minimum weight:
1. Heavy-Duty/Panzer Mesh: 20.0 oz./sq. yd. at bottom panels (within 8 ft of walking surface).
 2. Standard/I.S. Reinforcing Mesh: Not less than 5.0 oz./sq. yd.
 3. Strip Reinforcing Mesh: Not less than 3.75 oz./sq. yd. (127 g/sq. m).
 4. Corner Reinforcing Mesh: Not less than 7.2 oz./sq. yd. (244 g/sq. m).
- H. Base-Coat Materials: System manufacturer's standard mixture complying with the following requirements for material composition and method of combining materials:
1. Job-mixed formulation of portland cement complying with ASTM C 150, Type I, white or natural color; and manufacturer's standard polymer-emulsion adhesive designed for use indicated; "Genesis," or equivalent.
- I. Primer: System manufacturer's standard factory-mixed elastomeric-polymer primer for preparing base-coat surface for application of finish coat; "ColorPrime," or equivalent.
- J. Finish-Coat Materials: System manufacturer's standard mixture complying with the following requirements for material composition and method of combining materials:
1. Factory-mixed formulation of polymer-emulsion binder, colorfast mineral pigments, sound stone particles, and fillers; selected by Architect from "DPR Finish" textures and all available colors, or equivalent.
- K. Water: Potable.
- L. Trim Accessories: Type as designated or required to suit conditions indicated and to comply with system manufacturer's written requirements, manufactured from vinyl plastic and complying with ASTM C 1063.

1. Drip Screed: Prefabricated one-piece type for attachment behind insulation, of depth required to suit thickness of coating and insulation, with face leg perforated for bonding to coating and extended to form a drip; "Drainage Strip," or equivalent.
 - M. Elastomeric Sealant Products: Provide sealant in accordance with requirements of Division 07 "Joint Sealants" Section and as recommended by EIFS system manufacturer..
 - N. Fasteners: Type recommended by EIFS system manufacturer based on substrate.
 - O. Parapet Cap Flashing: Type for both flashing and covering parapet top, with design complying with ASTM C1397 and ANSI/SPRI/FM 4435/ES-1.
- 2.4 MIXING
- A. General: Comply with system manufacturer's requirements for combining and mixing materials. Do not introduce admixtures, water, or other materials except as recommended by system manufacturer. Mix materials in clean containers. Use materials within time period specified by system manufacturer or discard.

PART 3 - EXECUTION

3.1 EXAMINATION

- A. Examine substrates, areas, and conditions, with Installer present, for compliance with requirements for installation tolerances and other conditions affecting performance of system. Proceed with installation of system only after unsatisfactory conditions have been corrected.

3.2 PREPARATION

- A. Protect contiguous work from moisture deterioration and soiling caused by application of systems. Provide temporary covering and other protection needed to prevent spattering of exterior finish coats on other work.
- B. Protect system, substrates, and wall construction behind them from inclement weather during installation. Prevent infiltration of moisture behind system and deterioration of substrates.
- C. Prepare and clean substrates to comply with system manufacturer's written requirements to obtain optimum bond between substrate and adhesive for insulation.

3.3 SUBSTRATE PROTECTION APPLICATION

- A. Air and Moisture-resistive Weather Barrier: Apply over sheathing to provide a air and water-resistive barrier.
 1. Tape and seal joints, exposed edges, terminations, and inside and outside corners of sheathing unless otherwise indicated by EIFS manufacturer's written instructions.

- B. Flexible Flashing: Install over weather-resistive barrier, applied and lapped to shed water; seal at openings, penetrations, terminations, and where required by EIFS manufacturer. Prime substrates if required and install flashing to comply with EIFS manufacturer's written instructions and details.

3.4 TRIM INSTALLATION

- A. Trim: Apply trim accessories at perimeter of EIFS, at expansion joints, at windowsills, and elsewhere as indicated. Coordinate with installation of insulation.
 - 1. Weep Screed/Track (Drainage Strips): Use at bottom termination edges, at window and door heads, and at floor line expansion joints of water-drainage EIFS unless otherwise indicated.
 - 2. Windowsill Flashing: Use at windows unless otherwise indicated.
 - 3. Expansion Joint: Use where indicated on Drawings.
 - 4. Casing Bead: Use at other locations.
 - 5. Parapet Cap Flashing: Use where indicated on Drawings.

3.5 INSTALLATION

- A. Comply with ASTM C1397 and the EIFS manufacturer's system application instructions. Apply base coat sufficient to fully embed the reinforcing mesh. The recommended method is to apply the base coat in two (2) passes
- B. Board Insulation: Adhesively attach insulation to substrate in compliance with ASTM C 1397 and the following:
 - 1. Apply adhesive to insulation by notched-trowel method, with notches oriented vertically to produce drainage channels that remain functional after the insulation is adhered to substrate.
 - 2. Press and slide insulation board into place. Apply pressure over the entire surface of the insulation board to accomplish uniform contact, high initial grab, and an overall level surface.
 - 3. Allow adhered insulation to remain undisturbed for period recommended by system manufacturer, but not less than 24 hours, before beginning rasping and sanding insulation, or applying base coat and reinforcing mesh.
 - 4. Apply insulation boards over dry substrates in courses with long edges oriented horizontally. Begin first course from drip screed/drainage strip and work upward. Work from perimeter casing beads toward interior of panels if possible.
 - 5. Stagger vertical joints in successive courses to produce running bond pattern. Locate joints so no piece of insulation is less than 12 inches (300 mm) wide or 6 inches (150 mm) high. Offset joints not less than 6 inches (150 mm) from corners of window and door openings.
 - a. Offset joints of insulation not less than 6 inches (150 mm) from horizontal and 4 inches (100 mm) from vertical joints in sheathing.
 - 6. Interlock ends at internal and external corners.

7. Abut boards tightly at joints within and between each course to produce flush, continuously even surfaces without gaps or raised edges between insulation boards. If gaps greater than 1/16 inch (1.6 mm) occur, fill with insulation cut to fit gaps exactly; insert insulation without using adhesive or other material.
 8. Cut insulation to fit openings, corners, and projections precisely and to produce edges and shapes complying with details indicated.
 9. Rasp or sand flush entire surface of insulation to remove irregularities projecting more than 1/32 inch (0.8 mm) from surface of insulation and to remove yellowed areas due to sun exposure; do not create depressions deeper than 1/16 inch (1.6 mm).
 10. Score substrates to receive finish system to profiles indicated on drawings.
 11. Interrupt insulation for expansion joints where indicated.
 12. Form joints for sealant application by leaving gaps between adjoining insulation edges and between insulation edges and dissimilar adjoining surfaces. Make gaps wide enough to produce joint widths indicated after encapsulating joint substrates with base coat and reinforcing mesh.
 13. Treat exposed edges of insulation board as follows:
 - a. Wrap edges after installing insulation board and before applying field-applied reinforcing mesh.
 - b. Wrap mesh of width required to extend not less than 2-1/2 inches (63 mm) onto substrate behind insulation board, cover insulation board edge, and extend not less than 2-1/2 inches (63 mm) onto insulation board face.
 - c. Wrap edges of insulation board, except those forming substrates of sealant joints, by encapsulating with base coat, reinforcing mesh, and finish coat.
 - d. Wrap edges of insulation board forming substrates of sealant joints within system or between system and other work by encapsulating with base coat and reinforcing mesh.
 14. Treat edges of insulation board at trim accessories by extending base coat, reinforcing mesh, and finish coat over face leg of accessories.
 15. Coordinate flashing installation with installation of insulation to produce a wall system that does not allow water to penetrate behind protective coating.
- C. Install trim accessories at locations indicated according to system manufacturer's written instructions.
- D. Install expansion joints at locations indicated, where required by system manufacturer, and as follows:
1. Where expansion joints are indicated in substrates behind EIFS.
 2. Where EIFS adjoins dissimilar substrates, materials, and construction.
 3. Where wall height changes.
- E. Apply base coat to exposed surfaces of insulation in minimum thickness recommended in writing by system manufacturer, but not less than 1/16-inch (1.6-mm) dry-coat thickness.
- F. Embed reinforcing mesh of type indicated below in wet base coat to produce wrinkle-free installation with mesh continuous at corners and overlapped not less than 2-1/2 inches (64

mm) or otherwise treated at joints to comply with ASTM C 1397 and EIFS manufacturer's written instructions. Do not lap reinforcing mesh within 8 inches (204 mm) of corners. Completely embed mesh, applying additional base-coat material if necessary, so reinforcing-mesh color and pattern are not visible.

1. Heavy-Duty/Panzer Mesh: 20.0 oz./sq. yd. at bottom panels (within 8 ft of walking surface).
2. Standard/I.S. Reinforcing Mesh: Not less than 5.0 oz./sq. yd.

G. Additional Reinforcing Mesh: Apply strip reinforcing mesh around openings extending 4 inches (100 mm) beyond perimeter. Apply additional 9-by-12-inch (230-by-305-mm) strip reinforcing mesh diagonally at corners of openings (re-entrant corners). Apply 8-inch (200-mm-) wide strip reinforcing mesh at both inside and outside corners, unless base layer of mesh is lapped not less than 4 inches (100 mm) on each side of corners.

1. Embed strip reinforcing mesh in base coat before applying first layer of reinforcing mesh.

H. Double Base-Coat Application: At lower panels, apply second base coat in the same manner and thickness as first application, with standard reinforcing mesh. Do not apply until first base coat has cured.

I. Apply tinted primer over dry base coat according to system manufacturer's written instruction.

J. Apply finish coat over dry primer, maintaining a wet edge at all times for uniform appearance, in thickness required by system manufacturer to produce a uniform finish of color and texture matching approved sample.

3.6 INSTALLATION OF JOINT SEALANTS

A. Prepare joints and apply sealants, of type and at locations indicated, to comply with applicable requirements in Division 07 Section "Joint Sealants" and EIFS manufacturer's instructions.

1. Clean surfaces to receive sealants to comply with indicated requirements and system manufacturer's written instructions.
2. Apply primer recommended in writing by sealant manufacturer for surfaces to be sealed.
3. Install sealant backing to control depth and configuration of sealant joint and to prevent sealant from adhering to back of joint.
4. Apply masking tape to protect areas adjacent to sealant joints. Remove tape immediately after tooling joints, without disturbing joint seal.
5. Apply joint sealants after base coat has cured but before applying finish coat.

3.7 FIELD QUALITY CONTROL

A. Special Inspections: Owner will engage a qualified special inspector to perform required special inspections.

- B. EIFS will be considered defective if it does not pass tests and inspections.
- C. Prepare test and inspection reports

3.8 CLEANING AND PROTECTING

- A. Remove temporary covering and protection of other work. Promptly remove coating materials from window and door frames and other surfaces outside areas indicated to receive system coatings.
- B. Provide final protection and maintain conditions, in a manner acceptable to Installer and system manufacturer, that ensure system is without damage or deterioration at the time of Substantial Completion.

END OF SECTION 072419

SECTION 072726 - FLUID-APPLIED MEMBRANE AIR BARRIERS

PART 1 - GENERAL

1.1 SUMMARY

- A. Section includes fluid-applied, vapor-permeable membrane air barriers.
- B. Related Requirements:
 - 1. Section 061643 "Gypsum Sheathing" for wall sheathings and wall sheathing joint-and-penetration treatments.

1.2 DEFINITIONS

- A. Air-Barrier Material: A primary element that provides a continuous barrier to the movement of air.
- B. Air-Barrier Accessory: A transitional component of the air barrier that provides continuity.
- C. Air-Barrier Assembly: The collection of air-barrier materials and accessory materials applied to an opaque wall, including joints and junctions to abutting construction, to control air movement through the wall.

1.3 PREINSTALLATION MEETINGS

- A. Preinstallation Conference: Conduct conference at Project site.
 - 1. Review air-barrier requirements and installation, special details, mockups, air-barrier protection, and work scheduling that covers air barriers.

1.4 ACTION SUBMITTALS

- A. Product Data: For each type of product.
 - 1. Include manufacturer's written instructions for evaluating, preparing, and treating substrate; technical data; and tested physical and performance properties of products.
- B. Shop Drawings: For air-barrier assemblies.
 - 1. Show locations and extent of air barrier. Include details for substrate joints and cracks, counterflashing strips, penetrations, inside and outside corners, terminations, and tie-ins with adjoining construction.
 - 2. Include details of interfaces with other materials that form part of air barrier.

1.5 INFORMATIONAL SUBMITTALS

- A. Qualification Data: For Installer.
- B. Product Certificates: From air-barrier manufacturer, certifying compatibility of air barriers and accessory materials with Project materials that connect to or that come in contact with the barrier.
- C. Product Test Reports: For each air-barrier assembly, for tests performed by a qualified testing agency.

1.6 QUALITY ASSURANCE

- A. Installer Qualifications: An entity that employs installers and supervisors who are trained and approved by manufacturer.
- B. Mockups: Build mockups to set quality standards for materials and execution and for preconstruction testing.
 - 1. Install fluid-applied membrane air barriers system on mockups of exterior wall systems specified in other specification sections to demonstrate surface preparation, crack and joint treatment, application of air barriers, and sealing of gaps, terminations, and penetrations of air-barrier assembly.
 - a. Include junction with roofing membrane, building corner condition, and foundation wall intersection.
 - b. If Architect determines mockups do not comply with requirements, reconstruct mockups and apply air barrier until mockups are approved.
 - 2. Approval of mockups does not constitute approval of deviations from the Contract Documents contained in mockups unless Architect specifically approves such deviations in writing.

1.7 DELIVERY, STORAGE, AND HANDLING

- A. Remove and replace liquid materials that cannot be applied within their stated shelf life.
- B. Protect stored materials from direct sunlight.

1.8 FIELD CONDITIONS

- A. Environmental Limitations: Apply air barrier within the range of ambient and substrate temperatures recommended by air-barrier manufacturer.
 - 1. Protect substrates from environmental conditions that affect air-barrier performance.
 - 2. Do not apply air barrier to a damp or wet substrate or during snow, rain, fog, or mist.

1.9 WARRANTY

- A. Manufacturer's Warranty: Submit manufacturer's standard warranty form for membrane systems, include affirmation of waterproofing mock-up observation and approval as required by warranty provisions. Approval by manufacturer for warranty is required prior to system application. Submit manufacturer's "Request Form" and supporting documentation at completion of waterproofing application through the local Authorized Distributor of the materials.
 - 1. Warranty Period: Five years from date of Substantial Completion.
- B. Special Installer's Warranty: Installer's standard form in which installer agrees to repair or replace membranes that do not comply with performance and other requirements specified in this Section within specified warranty period.
 - 1. Warranty Period: Two years from date of Substantial Completion.

PART 2 - PRODUCTS

2.1 MATERIALS, GENERAL

- A. Source Limitations: Obtain primary air-barrier materials and air-barrier accessories from single source from single manufacturer.
- B. VOC Content: 250 g/L or less when calculated according to 40 CFR 59, Subpart D (EPA Method 24) and complying with VOC content limits of authorities having jurisdiction.

2.2 PERFORMANCE REQUIREMENTS

- A. General: Air barrier shall be capable of performing as a continuous vapor-retarding air barrier and as a liquid-water drainage plane flashed to discharge to the exterior incidental condensation or water penetration. Air-barrier assemblies shall be capable of accommodating substrate movement and of sealing substrate expansion and control joints, construction material changes, penetrations, tie-ins to installed waterproofing, and transitions at perimeter conditions without deterioration and air leakage exceeding specified limits.
- A. Air-Barrier Assembly Air Leakage: Maximum 0.04 cfm/sq. ft. of surface area at 1.57 lbf/sq. ft. (0.2 L/s x sq. m of surface area at 75 Pa) when tested according to ASTM E 283, ASTM E 783, or ASTM E 2357.
- B. Vertical and Lateral Fire Propagation Test Characteristics: The exterior wall assembly of the School Building is required to comply with NFPA 285 "Standard Method of Test for the Evaluation of Flammability Characteristics of Exterior Nonload-bearing Wall Assemblies Containing Combustible Components." The base wall, stud cavity insulation, wall sheathing, air barrier, continuous wall rigid insulation and exterior cladding are components that are required to be to be evaluated as part of this specific

assembly test. Membrane air and moisture barriers shall be part of an assembly that has passed NFPA 285 testing.

2.3 HIGH-BUILD VAPOR-PERMEABLE MEMBRANE AIR BARRIER

- A. Fluid-Applied, Vapor-Permeable Membrane Air Barrier: Synthetic polymer membrane with an installed dry film thickness, according to manufacturer's written instructions, of 35 mils (0.9 mm) or thicker over smooth, void-free substrates.
1. Basis of Design Product: Provide Henry Company; Air-Bloc 31MR or one of the following:
 - a. GCP Applied Technologies: Perm-A-Barrier VPL.
 - b. ExoAir 230 by Tremco.
 2. Physical and Performance Properties:
 - a. Air Permeance: Maximum 0.004 cfm/sq. ft. of surface area at 1.57-lbf/sq. ft. (0.02 L/s x sq. m of surface area at 75-Pa) pressure difference; ASTM E 2178.
 - b. Vapor Permeance: Minimum 10 perms (580 ng/Pa x s x sq. m); ASTM E 96/E 96M.
 - c. Ultimate Elongation: Minimum 200 percent; ASTM D 412, Die C.

2.4 ACCESSORY MATERIALS

- A. General: Provide primers, transition strips, termination strips, joint sealants, counterflashing strips, flashing sheets and metal termination bars, termination mastic, substrate patching materials, adhesives, tapes, foam sealants, lap sealants, and other accessory materials that are recommended in writing by air-barrier manufacturer to produce a complete air-barrier assembly and that are compatible with primary air-barrier material and adjacent construction to which they may seal.
- B. Primer: Liquid waterborne primer recommended for substrate by air-barrier material manufacturer.
1. Basis of Design Product: Aquatac by Henry Co., or equal.
- C. Liquid Flashing: Moisture cure single-component elastomeric liquid-applied flashing containing Silyl-Terminated Polyether (STPE) polymer, designed to cure through reaction with airborne moisture.
1. Basis of Design Product: Air-Bloc LF Liquid-Applied Flashing by Henry Co., or equal.
- D. Counterflashing Strip: Modified bituminous, 40-mil- (1.0-mm-) thick, self-adhering sheet consisting of 32 mils (0.8 mm) of rubberized asphalt laminated to an 8-mil- (0.2-mm-) thick, cross-laminated polyethylene film with release liner backing.
1. Basis of Design Product: Blueskin SA or Blueskin SA LT by Henry Co., or equal

PART 3 - EXECUTION

3.1 EXAMINATION

- A. Examine substrates, areas, and conditions, with Installer present, for compliance with requirements and other conditions affecting performance of the Work.
 - 1. Verify that substrates are sound and free of oil, grease, dirt, excess mortar, or other contaminants.
 - 2. Verify that concrete has cured and aged for minimum time period recommended by air-barrier manufacturer.
 - 3. Verify that concrete is visibly dry and free of moisture. Test for capillary moisture by plastic sheet method according to ASTM D 4263.
 - 4. Verify that masonry joints are flush and completely filled with mortar.
- B. Proceed with installation only after unsatisfactory conditions have been corrected.

3.2 SURFACE PREPARATION

- A. Clean, prepare, treat, and seal substrate according to manufacturer's written instructions. Provide clean, dust-free, and dry substrate for air-barrier application.
- B. Mask off adjoining surfaces not covered by air barrier to prevent spillage and overspray affecting other construction.
- C. Remove grease, oil, bitumen, form-release agents, paints, curing compounds, and other penetrating contaminants or film-forming coatings from concrete.
- D. Remove fins, ridges, mortar, and other projections and fill honeycomb, aggregate pockets, holes, and other voids in concrete with substrate-patching membrane.
- E. Remove excess mortar from masonry ties, shelf angles, and other obstructions.
- F. At changes in substrate plane, apply sealant or termination mastic beads at sharp corners and edges to form a smooth transition from one plane to another.
- G. Cover gaps in substrate plane and form a smooth transition from one substrate plane to another with 26 gauge stainless-steel sheet mechanically fastened to structural framing to provide continuous support for air barrier.
- H. Bridge isolation joints, expansion joints and discontinuous wall-to-wall, deck-to-wall, and deck-to-deck joints with air-barrier accessory material that accommodates joint movement according to manufacturer's written instructions and details.

3.3 ACCESSORIES INSTALLATION

- A. Install accessory materials according to air-barrier manufacturer's written instructions and details to form a seal with adjacent construction and ensure continuity of air and water barrier.
 - 1. Coordinate the installation of air barrier with installation of roofing membrane and base flashing to ensure continuity of air barrier with roofing membrane.
 - 2. Install transition strip on roofing membrane or base flashing so that a minimum of 3 inches (75 mm) of coverage is achieved over each substrate.
 - 3. Unless manufacturer recommends in writing against priming, apply primer to substrates at required rate and allow it to dry.
 - 4. Apply primer to substrates at required rate and allow it to dry. Limit priming to areas that will be covered by air-barrier material on same day. Reprime areas exposed for more than 24 hours.

- B. Connect and seal exterior wall air-barrier material continuously to roofing-membrane air barrier, concrete below-grade structures, floor-to-floor construction, exterior glazing and window systems, glazed curtain-wall systems, storefront systems, exterior louvers, exterior door framing, and other construction used in exterior wall openings, using accessory materials.

- C. At end of each working day, seal top edge of strips and transition strips to substrate with termination mastic.

- D. Apply joint sealants forming part of air-barrier assembly within manufacturer's recommended application temperature ranges. Consult manufacturer when sealant cannot be applied within these temperature ranges.

- E. Wall Openings: Prime concealed, perimeter frame surfaces of windows, curtain walls, storefronts, and doors. Apply transition strip/flashing so that a minimum of 3 inches (75 mm) of coverage is achieved over each substrate. Maintain 3 inches (75 mm) of full contact over firm bearing to perimeter frames, with not less than 1 inch (25 mm) of full contact.
 - 1. Transition Strip/Flashing: Roll firmly to enhance adhesion.

- F. Fill gaps in perimeter frame surfaces of windows, curtain walls, storefronts, and doors, and miscellaneous penetrations of air-barrier material with sealant.

- G. Terminations:
 - 1. Seal strips and transition strips around masonry reinforcing or ties and penetrations.
 - 2. Seal top of through-wall flashings to air barrier with an additional 6-inch- (150-mm-) wide, transition strip.
 - 3. Seal exposed edges of strips at seams, cuts, penetrations, and terminations not concealed by metal counterflashings or ending in reglets with sealant or liquid flashing.

- H. Repair punctures, voids, and deficient lapped seams in strips and transition strips. Slit and flatten fishmouths and blisters. Patch with transition strips extending 6 inches (150 mm) beyond repaired areas in strip direction.

3.4 FLUID AIR-BARRIER MEMBRANE INSTALLATION

- A. Apply air-barrier material to form a seal with strips and transition strips and to achieve a continuous air barrier according to air-barrier manufacturer's written instructions and details. Apply air-barrier material within manufacturer's recommended application temperature ranges.
 - 1. Unless manufacturer recommends in writing against priming, apply primer to substrates at required rate and allow it to dry.
 - 2. Limit priming to areas that will be covered by air-barrier material on same day. Reprime areas exposed for more than 24 hours.
 - 3. Where multiple prime coats are needed to achieve required bond, allow adequate drying time between coats
- B. High-Build Membrane Air Barriers: Apply a continuous unbroken air-barrier membrane to substrates according to the following thickness. Apply air-barrier membrane in full contact around protrusions such as masonry ties.
 - 1. Vapor-Permeable Membrane Air Barrier: Total dry film thickness as recommended in writing by manufacturer to meet performance requirements, but not less than 35-mil (0.9-mm) dry film thickness, applied in one or more equal coats.
- C. Do not cover air barrier until it has been tested and inspected by Owner's testing agency.
- D. Correct deficiencies in or remove air barrier that does not comply with requirements; repair substrates and reapply air-barrier components.

3.5 FIELD QUALITY CONTROL

- A. Testing Agency: Owner may engage a Project Inspector to perform inspections.
- B. Inspections: Air-barrier materials, accessories, and installation are subject to inspection for compliance with requirements. Inspections may include the following:
 - 1. Continuity of air-barrier system has been achieved throughout the building envelope with no gaps or holes.
 - 2. Continuous structural support of air-barrier system has been provided.
 - 3. Masonry and concrete surfaces are smooth, clean, and free of cavities, protrusions, and mortar droppings.
 - 4. Site conditions for application temperature and dryness of substrates have been maintained.
 - 5. Maximum exposure time of materials to UV deterioration has not been exceeded.
 - 6. Surfaces have been primed, if applicable.

7. Laps in strips and transition strips have complied with minimum requirements and have been shingled in the correct direction (or mastic has been applied on exposed edges), with no fishmouths.
8. Termination mastic has been applied on cut edges.
9. Strips and transition strips have been firmly adhered to substrate.
10. Compatible materials have been used.
11. Transitions at changes in direction and structural support at gaps have been provided.
12. Connections between assemblies (air-barrier and sealants) have complied with requirements for cleanliness, surface preparation and priming, structural support, integrity, and continuity of seal.
13. All penetrations have been sealed.

C. Air barriers will be considered defective if they do not pass tests and inspections.

1. Apply additional air-barrier material, according to manufacturer's written instructions, where inspection results indicate insufficient thickness.

D. Repair damage to air barriers caused by testing; follow manufacturer's written instructions.

3.6 CLEANING AND PROTECTION

A. Protect air-barrier system from damage during application and remainder of construction period, according to manufacturer's written instructions.

1. Protect air barrier from exposure to UV light and harmful weather exposure as required by manufacturer. If exposed to these conditions for more than 30 days, remove and replace air barrier or install additional, full-thickness, air-barrier application after repairing and preparing the overexposed membrane according to air-barrier manufacturer's written instructions.
2. Protect air barrier from contact with incompatible materials and sealants not approved by air-barrier manufacturer.

B. Clean spills, stains, and soiling from construction that would be exposed in the completed work using cleaning agents and procedures recommended by manufacturer of affected construction.

C. Remove masking materials after installation.

END OF SECTION 072726

SECTION 074114 - METAL-FACED INSULATING GLAZING PANELS

PART 1 - GENERAL

1.1 SUMMARY

- A. This Section includes the following:

1. Insulated metal-faced wall panels for glazing into storefront framing.

1.2 SUBMITTALS

- A. Product Data: Include construction details, material descriptions, dimensions of individual components and profiles, and finishes for each type of metal panel and accessory.
- B. Shop Drawings: Show fabrication and installation layouts of metal panels; details of edge conditions, joints, panel profiles, corners, and special details. Distinguish between factory- and field-assembled work.
- C. Samples for Initial Selection: For each type of metal-faced panel indicated with factory-applied color finishes.

1.3 DELIVERY, STORAGE, AND HANDLING

- A. Deliver components, sheets, metal panels, and other manufactured items so as not to be damaged or deformed. Package metal panels for protection during transportation and handling.
- B. Unload, store, and erect metal panels in a manner to prevent bending, warping, twisting, and surface damage.
- C. Stack metal panels on platforms or pallets, covered with suitable weathertight and ventilated covering. Store metal panels to ensure dryness. Do not store metal panels in contact with other materials that might cause staining, denting, or other surface damage.
- D. Protect strippable protective covering on metal panels from exposure to sunlight and high humidity, except to extent necessary for period of metal panel installation.

1.4 PROJECT CONDITIONS

- A. Field Measurements: Verify locations of framing dimensions by field measurements before metal panel fabrication and indicate measurements on Shop Drawings.

PART 2 - PRODUCTS

2.1 PANEL MATERIALS

- A. Aluminum Sheet: Coil-coated sheet, ASTM B 209 (ASTM B 209M), alclad alloy 3003, 3004, or 3105 for painted finishes, with temper as required to suit forming operations and structural performance required.

2.2 METAL-FACED INSULATED WALL PANELS

- A. Insulated Metal Panels: Manufacturer's standard laminated aluminum-faced panels of overall thickness indicated, flat with no deviations in plane exceeding 1/16 inch in 24 inches (1.5 mm in 600 mm) or 1/8 inch (3 mm) over entire panel, forming outer skin of insulated panels with core of rigid insulation between panels.
 - 1. Face Panels Fabrication: Face panels shall be coil coated aluminum sheet bonded to solid substrate.
 - a. Aluminum Sheet Thickness: 0.032"
 - b. Substrate: 1/8" tempered hardboard.
 - c. Exposed Panel Texture: Smooth.
 - d. Exposed Panel Finish: Painted enamel or powder paint, in color as selected by Architect from full range of colors.
 - 2. Core: Rigid, polyisocyanurate 1.7 lb. density
 - 3. Edge Configuration: Unsealed.
 - 4. Overall Panel Thickness: 1".
 - 5. Basis of Design Product: Mapes-R Panel by Mapes Architectural Products or equal.

2.3 FABRICATION

- A. General: Fabricate and finish metal panels at the factory to greatest extent possible, by manufacturer's standard procedures and processes, as necessary to fulfill indicated performance requirements demonstrated by laboratory testing. Comply with indicated profiles and with dimensional and structural requirements.

2.4 FINISHES, GENERAL

- A. Comply with NAAMM's "Metal Finishes Manual for Architectural and Metal Products" for recommendations for applying and designating finishes.
- B. Protect mechanical and painted finishes on exposed surfaces from damage by applying a strippable, temporary protective covering before shipping.
- C. Appearance of Finished Work: Variations in appearance of abutting or adjacent pieces are acceptable if they are within one-half of the range of approved Samples. Noticeable variations in the same piece are not acceptable. Variations in appearance of other components are acceptable if they are within the range of approved Samples and are assembled or installed to minimize contrast.

PART 3 - EXECUTION

3.1 EXAMINATION

- A. Examine substrates, areas, and conditions, with Installer present, for compliance with requirements for installation tolerances, metal panel supports, and other conditions affecting performance of work.
- B. Proceed with installation only after unsatisfactory conditions have been corrected.

3.2 PANEL INSTALLATION, GENERAL

- A. General: Install metal-faced panels in orientation, sizes, and locations indicated on Drawings and in compliance with approved shop-drawings. Anchor metal-faced panels and other components of the Work securely in place, with provisions for thermal and structural movement.
 - 1. Field cutting of metal-faced glazing panels is not permitted.
- B. Metal Protection: Where dissimilar metals will contact each other or corrosive substrates, protect against galvanic action by painting contact surfaces with bituminous coating, by applying rubberized-asphalt underlayment to each contact surface, or by other permanent separation as recommended by metal-faced panel manufacturer.

3.3 CLEANING AND PROTECTION

- A. Remove temporary protective coverings and strippable films, if any, as metal panels are installed, unless otherwise indicated in manufacturer's written installation instructions. On completion of metal panel installation, clean finished surfaces as recommended by metal panel manufacturer. Maintain in a clean condition during construction.
- B. Replace metal panels that have been damaged or have deteriorated beyond successful repair by finish touchup or similar minor repair procedures.

END OF SECTION 074114

SECTION 074213.53 - COMPOSITE METAL WALL AND SOFFIT PANELS

PART 1 - GENERAL

1.1 SUMMARY

A. This Section includes the following:

1. Metal-faced composite core wall panels used for soffits, fascia cladding, wall panels, cornice cladding, copings, and other applications.
2. Metal wall panel accessories including closures, fasteners and clips, corners, flashings, and other components of wall panel system.
3. Wall panel stub framing system.
 - a. Subframing required to support the composite core wall panel profiles indicated on the Drawings shall be part of the system designed under this Section.

B. Related Sections include the following:

1. Division 05 Section "Cold-Formed Metal Framing" for secondary support framing supporting metal panels.
2. Division 07 Section "Joint Sealants" for field-applied sealants not otherwise specified in this Section.

1.2 ACTION SUBMITTALS

A. Product Data: Include construction details, material descriptions, dimensions of individual components and profiles, and finishes for each type of metal panel and accessory.

B. Shop Drawings: Show fabrication and installation layouts of metal panels; details of edge conditions, joints, panel profiles, corners, anchorages, attachment systems, trim, flashings, closures, and accessories; and special details. Distinguish between factory- and field-assembled work.

1. Include structural data indicating compliance with performance requirements including analysis data signed and sealed by the qualified professional engineer responsible for their preparation.
2. Indicate coordination dimensions related to structural support system elements provided by others.

C. Samples for Initial Selection:

1. Include Samples of trim and accessories involving color selection.
2. Include manufacturer's color charts consisting of strips of cured sealants showing the full range of colors available for each sealant exposed to view

- D. Samples for Verification: For each type of exposed finish required, prepared on Samples of size indicated below.
1. Metal Panels: 12 inches (300 mm) long by actual panel width. Include fasteners, clips, closures, and other metal panel accessories.
 2. Trim and Closures: 12 inches (300 mm) long. Include fasteners and other exposed accessories.
 3. Sealants: 12 inches (300 mm) long strips of cured sealants showing the colors to be provided for each sealant exposed to view

1.3 INFORMATIONAL SUBMITTALS

- A. Qualification Data: For Installer.
- B. Maintenance Data: For metal panels to include in maintenance manuals.
- C. Warranties: Special warranties specified in this Section.

1.4 QUALITY ASSURANCE

- A. Installer Qualifications: An employer of workers trained and approved by manufacturer. Firm shall have completed work similar in material, design, and extent to that indicated for this Project with a record of successful in-service performance.
- B. Source Limitations: Obtain each type of metal panels through one source from a single manufacturer.
- C. Mockups: Prior to installing composite metal wall panels, construct mockups for each form of construction and finish required to verify selections made under Sample submittals and to demonstrate aesthetic effects as well as qualities of materials and execution. Build mockups to comply with the following requirements, using materials indicated for Work.
1. Provide mock-up of roof coping/cornice assembly for each different configuration.
 2. Locate mockups on-site in the location and of the size indicated or, if not indicated, as directed by Architect.
 3. Include exposed sealant joint in mock-up.
 4. Notify Architect 7 days in advance of the dates and times when mockups will be constructed.
 5. Demonstrate the proposed range of aesthetic effects and workmanship.
 6. Obtain Architect's approval of mockups before start of Work.
 7. Retain and maintain mockups during construction in an undisturbed condition as a standard for judging the completed Work.
- D. Professional Engineer Qualifications: A professional engineer who is legally qualified to practice in the jurisdiction where Project is located and who is experienced in providing engineering services of the kind indicated. Engineering services are defined as those performed for installations of metal wall panel systems including secondary

framing that are similar to those indicated for this Project in material, design, and extent.

- E. Preconstruction Compatibility and Adhesion Testing: Submit samples of materials that will contact joint sealants to joint-sealant manufacturers for testing indicated in subparagraphs below:
1. Use manufacturer's standard test methods to determine whether priming and other specific joint preparation techniques are required to obtain rapid, optimum adhesion of joint sealants to joint substrates.
 - a. Perform tests under environmental conditions replicating those that will exist during installation.
 2. Submit no fewer than nine pieces of each type of material, including joint substrates, shims, joint-sealant backings, secondary seals, and miscellaneous materials.
 3. Schedule enough time for testing and analyzing results to prevent delaying the Work.
 4. For materials failing tests, obtain joint-sealant manufacturer's written instructions for corrective measures, including use of specially formulated primers.

1.5 DELIVERY, STORAGE, AND HANDLING

- A. Deliver components, sheets, metal panels, and other manufactured items so as not to be damaged or deformed. Package metal panels for protection during transportation and handling.
- B. Unload, store, and erect metal panels in a manner to prevent bending, warping, twisting, and surface damage.
- C. Stack metal panels on platforms or pallets, covered with suitable weathertight and ventilated covering. Store metal panels to ensure dryness. Do not store metal panels in contact with other materials that might cause staining, denting, or other surface damage.
- D. Protect strippable protective covering on metal panels from exposure to sunlight and high humidity, except to extent necessary for period of metal panel installation.

1.6 PROJECT CONDITIONS

- A. Weather Limitations: Proceed with installation only when existing and forecasted weather conditions permit assembly of metal panels to be performed according to manufacturers' written instructions and warranty requirements.
- B. Field Measurements: Verify locations of framing dimensions by field measurements before metal panel fabrication and indicate measurements on Shop Drawings.

1.7 WARRANTY

- A. Special Warranty: Manufacturer's standard form in which manufacturer agrees to repair or replace components of metal panel assemblies that fail in materials or workmanship within specified warranty period.
 - 1. Failures include, but are not limited to, the following:
 - a. Structural failures, including rupturing, cracking, or puncturing.
 - b. Deterioration of metals, metal finishes, and other materials beyond normal weathering.
 - 2. Warranty Period: Two years from date of Substantial Completion.
- B. Special Warranty on Panel Finishes: Manufacturer's standard form in which manufacturer agrees to repair finish or replace metal wall panels that show evidence of deterioration of factory-applied finishes within specified warranty period.
 - 1. Fluoropolymer Finish: Deterioration includes, but is not limited to, the following:
 - a. Color fading more than 5 Hunter units when tested according to ASTM D 2244.
 - b. Chalking in excess of a No. 8 rating when tested according to ASTM D 4214.
 - c. Cracking, checking, peeling, or failure of paint to adhere to bare metal.
 - 2. Finish Warranty Period: 20 years from date of Substantial Completion.

PART 2 - PRODUCTS

2.1 PERFORMANCE REQUIREMENTS

- A. General: Provide metal panel assemblies that comply with performance requirements specified as determined by testing manufacturers' standard assemblies similar to those indicated for this Project, by a qualified testing and inspecting agency.
- B. Thermal Movements: Provide metal panel assemblies that allow for thermal movements resulting from the following maximum change (range) in ambient and surface temperatures by preventing buckling, opening of joints, overstressing of components, failure of joint sealants, failure of connections, and other detrimental effects. Base engineering calculation on surface temperatures of materials due to both solar heat gain and nighttime-sky heat loss.
 - 1. Temperature Change (Range): 120 deg F (67 deg C), ambient; 180 deg F (100 deg C), material surfaces.
- C. Air Infiltration: Air leakage through assembly of not more than 0.06 cfm/sq. ft. (0.3 L/s per sq. m) of wall area when tested according to ASTM E 283 at the following test-pressure difference:
 - 1. Test-Pressure Difference: 1.57 lbf/sq. ft. (75 Pa) for metal-faced composite core wall panels.

- D. Water Penetration under Static Pressure: No water penetration when tested according to ASTM E 331 at the following test-pressure difference:
 - 1. Test-Pressure Difference: 6.24 lbf/sq. ft. (300 Pa) for metal-faced composite core wall panels.
- E. Structural Performance: Metal wall panel assemblies shall withstand the effects the following loads and stresses within limits and under conditions indicated, based on testing according to ASTM E 330:
 - 1. Wind Loads: Determine loads based on the following minimum design wind pressures:
 - a. Uniform pressure as indicated on Structural Drawings.
 - 2. Deflection Limits: Metal wall panel assemblies shall withstand wind loads with horizontal deflections no greater than the following
 - a. 1/175 of the span at the perimeter and 1/60 of the span anywhere in the panel for metal-faced composite core wall panels.
 - 3. Secondary Framing: Design secondary framing system according to AISI "Standard for Cold-Formed Steel Framing - General Provisions."
- F. Vertical and Lateral Fire Propagation Test Characteristics: The exterior wall assembly of the School Building is required to comply with NFPA 285 "Standard Method of Test for the Evaluation of Flammability Characteristics of Exterior Nonload-bearing Wall Assemblies Containing Combustible Components." The base wall, stud cavity insulation, wall sheathing, air barrier, continuous wall rigid insulation and exterior cladding are components that are required to be to be evaluated as part of this specific assembly test. Metal wall and soffit panels shall be part of an assembly that has passed NFPA 285 testing.

2.2 PANEL MATERIALS

- A. Aluminum Sheet: Coil-coated sheet, ASTM B 209 (ASTM B 209M), alloy as standard with manufacturer, with temper as required to suit forming operations and structural performance required.

2.3 MISCELLANEOUS METAL FRAMING

- A. Steel Sheet Components, General: Complying with ASTM C 645 requirements for metal and with ASTM A 653/A 653M, G60 (Z180), hot-dip galvanized zinc coating.
- B. Subgirts: C- or Z-shaped sections fabricated from 0.0598-inch (1.5-mm) bare steel thickness, shop-painted, cold-formed, metallic-coated steel sheet.
- C. Base or Sill Angles and Channels: 0.079-inch (2.0-mm) bare steel thickness, cold-formed, galvanized steel sheet.
- D. Hat-Shaped, Rigid Furring Channels: ASTM C 645.

1. Minimum Base Metal Thickness: 0.0179 inch (0.45 mm).
 2. Depth: 7/8 inch (22 mm) unless otherwise indicated.
- E. Cold-Rolled Furring Channels: 0.0538-inch (1.37-mm) bare steel thickness, with minimum 1/2-inch- (13-mm-) wide flange.
1. Depth: As indicated.
- F. Furring Brackets: Adjustable, corrugated-edge type of steel sheet with minimum bare steel thickness of 0.0312 inch (0.79 mm).
- G. Tie Wire: ASTM A 641/A 641M, Class 1 zinc coating, soft temper, 0.0625-inch- (1.59-mm-) diameter wire, or double strand of 0.0475-inch- (1.21-mm-) diameter wire.
- H. Fasteners for Metal Framing: Of type, material, size, corrosion resistance, holding power, and other properties required to fasten steel members to substrates.

2.4 MISCELLANEOUS MATERIALS

- A. Fasteners: Self-tapping screws, bolts, nuts, self-locking rivets and bolts, end-welded studs, and other suitable fasteners designed to withstand design loads. Provide exposed fasteners with heads matching color of metal panels by means of plastic caps or factory-applied coating.
1. Fasteners for Panels: Self-drilling or self-tapping, zinc-plated, hex-head carbon-steel screws, with a stainless-steel cap or zinc-aluminum-alloy head and EPDM or neoprene sealing washer.

2.5 METAL-FACED COMPOSITE CORE WALL AND SOFFIT PANELS

- A. General: Provide factory-formed and -assembled, metal-faced composite panels fabricated from two metal facings bonded, using no glues or adhesives, to solid, extruded thermoplastic core; formed into profile for installation method indicated. Include attachment system components and accessories required for weathertight system. Metal composite panel system shall be a full system that includes the sub-framing designed by system supplier's professional engineer.
1. Surface-Burning Performance: Product shall have the following surface-burning characteristics as determined by testing identical products per ASTM E 84 by UL or another testing and inspecting agency acceptable to authorities having jurisdiction:
 - a. Flame-Spread Index: 25 or less.
 - b. Smoke-Developed Index: 450 or less.
 2. Basis of Design Product: Provide Alucobond PLUS manufactured by 3A composites USA or equal products of one of the following:
 - a. Arconic Architectural Products (USA).
 - b. Mitsubishi Chemical Composites.

- B. Aluminum-Faced Composite Wall Panels: Formed with 0.020-inch- (0.50-mm-) thick, coil-coated aluminum sheet facings.
 - 1. Panel Thickness: 4 mm.
 - 2. Core: Fire retardant core.
 - 3. Exterior Finish for Aluminum: Three-coat fluoropolymer. AAMA 620/621. Fluoropolymer finish containing not less than 70 percent PVDF resin by weight in both color coats. Prepare, pretreat, and apply coating to exposed metal surfaces to comply with coating and resin manufacturers' written instructions.
 - a. Color: As selected by Architect from manufacturer's full range.
- C. Attachment System Components: Formed from extruded aluminum.
 - 1. Include manufacturer's standard perimeter extrusions with integral weather stripping, panel stiffeners, panel clips and anchor channels as indicated or as required for a complete assembly.
- D. System Installation Method: Rout and return wet seal.
- E. Applications: Soffits, fascia, copings, cornice, wall cladding, trim, and other articulated exterior metal wall panels, and other applications indicated on Drawings.
- F. Flashing and Trim Color: Same material, finish, and color as facings of adjacent panels

2.6 ACCESSORIES

- A. Wall Panel Accessories: Provide components required for a complete metal wall panel assembly including trim, copings, fasciae, mullions, sills, corner units, clips, flashings, sealants, gaskets, fillers, closure strips, and similar items. Match material and finish of metal wall panels, unless otherwise indicated.

2.7 FABRICATION

- A. General: Fabricate and finish metal panels and accessories at the factory to greatest extent possible, by manufacturer's standard procedures and processes, as necessary to fulfill indicated performance requirements demonstrated by laboratory testing. Comply with indicated profiles and with dimensional and structural requirements.
- B. Fabricate metal wall panels in a manner that eliminates condensation on interior side of panel and with joints between panels designed to form weathertight seals
- C. Metal-Faced Composite Wall Panels: Factory form panels in a continuous process with no glues or adhesives between dissimilar materials. Trim and square edges of sheets with no displacement of face sheets or protrusion of core material.
 - 1. Form panel lines, breaks, and angles to be sharp and true, with surfaces free from warp and buckle.
 - 2. Fabricate panels with sharply cut edges, with no displacement of face sheets or protrusion of core material.

3. Fabricate panels with panel stiffeners, as required to comply with deflection limits, attached to back of panels with structural silicone sealant or bond tape.
 4. Dimensional Tolerances:
 - a. Panel Bow: 0.8 percent maximum of panel length or width.
 - b. Squareness: 0.25 inch (5 mm) maximum.
- D. Sheet Metal Accessories: Fabricate flashing and trim to comply with recommendations in SMACNA's "Architectural Sheet Metal Manual" that apply to the design, dimensions, metal, and other characteristics of item indicated.
1. Form exposed sheet metal accessories that are without excessive oil canning, buckling, and tool marks and that are true to line and levels indicated, with exposed edges folded back to form hems.
 2. Sealed Joints: Form nonexpansion but movable joints in metal to accommodate elastomeric sealant to comply with SMACNA standards.
 3. Conceal fasteners and expansion provisions where possible. Exposed fasteners are not allowed on faces of accessories exposed to view.
 4. Fabricate cleats and attachment devices from same material as accessory being anchored or from compatible, noncorrosive metal recommended by metal panel manufacturer.
 - a. Size: As recommended by SMACNA's "Architectural Sheet Metal Manual" or metal panel manufacturer for application but not less than thickness of metal being secured.

2.8 FINISHES, GENERAL

- A. Comply with NAAMM's "Metal Finishes Manual for Architectural and Metal Products" for recommendations for applying and designating finishes.
- B. Protect mechanical and painted finishes on exposed surfaces from damage by applying a strippable, temporary protective covering before shipping.
- C. Appearance of Finished Work: Variations in appearance of abutting or adjacent pieces are acceptable if they are within one-half of the range of approved Samples. Noticeable variations in the same piece are not acceptable. Variations in appearance of other components are acceptable if they are within the range of approved Samples and are assembled or installed to minimize contrast.

PART 3 - EXECUTION

3.1 EXAMINATION

- A. Examine substrates, areas, and conditions, with Installer present, for compliance with requirements for installation tolerances, metal panel supports, and other conditions affecting performance of work.

- B. Examine primary and secondary framing to verify that structural panel support members and anchorages have been installed within alignment tolerances required by manufacturer.
 - 1. Examine roughing-in for components and systems penetrating metal panels to verify actual locations of penetrations relative to seam locations of metal panels before metal panel installation
- C. Proceed with installation only after unsatisfactory conditions have been corrected.

3.2 PREPARATION

- A. Miscellaneous Framing: Install subpurlins, eave angles, furring, and other miscellaneous panel support members and anchorage according to metal panel manufacturer's written recommendations.

3.3 METAL PANEL INSTALLATION, GENERAL

- A. General: Anchor metal panels and other components of the Work securely in place, with provisions for thermal and structural movement.
 - 1. Factory cut metal panels as required for penetrations and openings. Cut openings as small as possible, neatly to size required, and without damage to adjacent metal panel finishes.
 - a. Field cutting of metal panels by saw or torch is not permitted.
 - 2. Install metal panels perpendicular to structural supports, unless otherwise indicated.
 - 3. Flash and seal metal panels with weather closures at perimeter of openings and similar elements. Fasten with self-tapping screws.
- B. Metal Protection: Where dissimilar metals will contact each other or corrosive substrates, protect against galvanic action by painting contact surfaces with bituminous coating, by applying rubberized-asphalt underlayment to each contact surface, or by other permanent separation as recommended by metal panel manufacturer.
- C. Joint Sealers: Install sealants where indicated and where required for weatherproof performance of metal panel assemblies. Provide types of gaskets, fillers, and sealants indicated or, if not indicated, types recommended by metal panel manufacturer.

3.4 METAL WALL AND SOFFIT PANEL INSTALLATION

- A. General: Install metal wall panels in orientation, sizes, and locations indicated on Drawings. Anchor metal wall panels and other components of the Work securely in place, with provisions for thermal and structural movement.
 - 1. Shim or otherwise plumb substrates receiving metal wall panels.
 - 2. Install flashing and trim as metal wall panel work proceeds.

- B. Clip Installation: Attach panel clips to supports at each metal-faced composite wall panel joint at locations, spacings, and with fasteners recommended by manufacturer. Attach routed-and-turned flanges of wall panels to panel clips with manufacturer's standard fasteners.
 - 1. Seal horizontal and vertical joints between adjacent panels with sealant backing and sealant. Install sealant backing and sealant according to requirements specified in Division 07 Section "Joint Sealants."
 - 2. Install semi-rigid mineral wool between subframing for the clip installation system where indicated.
- C. Installation Tolerances: Shim and align metal wall panels within installed tolerance of 1/4 inch in 20 feet (6 mm in 6 m), nonaccumulative, on level, plumb, and location lines as indicated and within 1/8-inch (3-mm) offset of adjoining faces and of alignment of matching profiles.

3.5 CLEANING AND PROTECTION

- A. Remove temporary protective coverings and strippable films, if any, as metal panels are installed, unless otherwise indicated in manufacturer's written installation instructions. On completion of metal panel installation, clean finished surfaces as recommended by metal panel manufacturer. Maintain in a clean condition during construction.
- B. Replace metal panels that have been damaged or have deteriorated beyond successful repair by finish touchup or similar minor repair procedures.

END OF SECTION 074213.53

SECTION 075323 - EPDM ROOFING

PART 1 - GENERAL

1.1 RELATED DOCUMENTS

- A. Applicable provisions of the Conditions of the Contract and Division 1, General Requirements, govern work in this Section.

1.2 DESCRIPTION OF WORK

- A. The work of this section consists of all plant, labor, materials, equipment, testing and services necessary to complete the work shown on the drawings, schedules, and keynotes, as specified, and as may be required by conditions and authorities having jurisdiction, including, but not limited to, the following:
 - 1. Inspect the underside of the roof deck before starting work, and periodically each day as work occurs, to determine if there are conduits, pipes, ceiling hangers or fixtures next to the deck or fastened to the deck that could be affected as roof work occurs.
 - a. Perform roof work so any conduits, pipes, ceiling hangers or fixtures are not disturbed.
 - b. Replace and reset any conduits, pipes, ceiling hangers or fixtures that are affected by the work.
 - 2. Clean all residual material and debris from the surface of the decks, and from within the flutes of the steel decks.
 - 3. Install a new fully adhered unreinforced 60 mil thick EPDM roofing system, including a vapor barrier on concrete deck areas, thermal barrier, insulation, cover board, flashing, stripping and related accessories.
 - 4. Install new flashings at the roof drains, and all roof-mounted and roof-penetrating equipment.
 - 5. Cover rooftop ductwork with isocyanurate insulation and fully adhered unreinforced EPDM. Configure the insulation so the top surfaces slope for drainage. Install acrylic color coating on the EPDM duct wrap.
 - 6. Protect roof surfaces where material and equipment is placed on them, and where construction traffic occurs, with 6 mil fire retardant polyethylene covered with 1-1/2 inch thick foam insulation, overlaid with 2 by 10 wooden planks.

1.3 RELATED WORK SPECIFIED ELSEWHERE

- A. The entire project specification with particular reference to these sections:
 - 1. Masonry - Division 4
 - 2. Carpentry - Division 6

- 3. Sheet Metal Flashing & Specialties - Section 07 6200
- 4. Roof Accessories - Section 07 7200

1.4 CODE APPROVAL REQUIREMENTS

- A. Install roofing and insulation system components to meet the following minimum requirements:
 - 1. New York State Uniform Fire Prevention and Building Code, which includes by reference the New York State Energy Conservation Code.
 - 2. Underwriters Laboratories Inc. Class A External Fire Rating for roof assemblies tested in accordance with ASTM E 108 or UL 790.
 - 3. Underwriters Laboratories Inc. Standard 1256 for roof assemblies with foam insulation.
 - 4. Minimum wind uplift pressure calculated using ASCE 7 and a safety factor of 2:
 - a. Field Zone - 90 psf
 - b. Perimeter Zones - 135 psf
 - c. Corner Zone - 165 psf
- B. Provide written certification from the roof material Manufacturer, before beginning work, to confirm the roofing system meets these requirements.

1.5 QUALITY ASSURANCE

- A. Installer Qualifications:
 - 1. A firm (Installer) with at least 5 continuous years experience performing work similar to that required for this project, employing personnel skilled in the work specified.
 - a. The Installer shall directly employ the personnel performing the work of this section.
 - b. The Installer shall have a full time supervisor on the roof when work is in progress. The Supervisor shall have a minimum of 5 years experience with work similar in nature and scope to this project, and speak fluent English.
 - 1. Submit the supervisor's resume upon request.
 - 2. The Installer shall provide a reference list of at least three previously completed projects of comparable size and similar design within a fifty mile radius of this project, which may be observed by representatives of the Owner:
 - a. The reference list shall include at a minimum, the completion date, a description of the work performed, the Owner's name - contact person - phone number and address and the Architect's name - contact person and phone number.
 - b. Submit the reference list upon request.

3. The Installer shall be acceptable to or licensed by the Manufacturer of the primary roofing materials, and provide written certification from the Manufacturer to confirm this prior to award if requested.
- B. Material Quality: Obtain each product, including the insulation, cover board, roof and flashing sheets, and the cements, primers and adhesives from a single Manufacturer which has manufactured the same products in the United States of America for not less than 5 continuous years.
- C. Material Quality: Obtain each type of material from a single source to ensure consistent quality, color, pattern, and texture.

1.6 PRE-CONSTRUCTION CONFERENCE

- A. Meet at the project site approximately two weeks prior to starting work, with the Architect, Owner and other representatives to discuss the following:
 1. How new roofing will be coordinated with the installation of the vapor barrier, thermal barrier, insulation, cover board, flashings and other items to provide a watertight installation.
 2. Generally accepted industry practice and the Manufacturer's instructions for handling and installing his products.
 3. The condition of the substrate (deck), curbs, penetrations and other preparatory work needed.
 4. Incomplete submittals; note that progress payments will be not processed until all submittals are received and approved.
 5. The construction schedule, weather forecast, availability of materials, personnel, equipment and facilities needed to proceed and complete the work on schedule.
 6. A schedule for Manufacturer and Architect inspections.

1.7 SUBMITTALS

- A. Submit the following items far enough in advance to obtain approval prior to performing any work on site:
 1. A pre-work inspection report with photos to document the condition of the roof deck, equipment curbs and overall building before work starts.
 2. Written certification from the Manufacturer which states that the Installer is acceptable or licensed to install the specified roofing; if not previously provided.
 3. Manufacturer's technical data sheets for all materials.
 4. Samples of the Contractor's Guarantee and Manufacturer's warranty forms.
 5. Test reports and certifications substantiating compliance with specification requirements, but only if requested by the Architect.

- B. Simultaneously provide all technical submittals needed for this project, for all technical sections, collated by section. Incomplete submittals will not be reviewed.
 - 1. Submittals shall be prepared and made by the firm that will perform the actual work.
 - 2. Provide electronic submittals via an on-line submittal exchange program if one is established for this project; if an on-line program isn't established, provide the submittals on portable USB drives in pdf format, organized in folders by Section.
- C. Safety Data Sheets: Simultaneously provide all Safety Data Sheets needed for this project, for all specification sections - collated by section, in three ring binders. Provide two binders for each building.
- D. Payment requisitions will not be processed until all submittals are received and approved.

1.8 JOB CONDITIONS (CAUTIONS & WARNINGS)

- A. Do not use oil or solvent based roof cement with EPDM roofing. Do not allow waste products, (petroleum grease or oil, solvents, vegetable or mineral oil, animal fat) or direct steam venting to come in contact with any roofing, insulation or flashing product. Do not expose EPDM roofing and accessories to a temperature in excess of 175 degrees Fahrenheit.
- B. Splice cleaner, primer, cements and bonding adhesives are flammable. Do not breathe vapors or use near fire or flame or in a confined or unventilated area. Dispense only from a UL listed safety can or the Manufacturer's original container.
- C. Remove empty adhesive, cleaner and solvent containers and contaminated rags from the roof and legally dispose of them daily.
- D. Do not apply primer, cleaners or adhesives next to ventilation system louvers or windows. Temporarily cover the louvers and windows with 6 mil fire retardant polyethylene and prevent odors from entering the building. Remove temporary covers at the end of each work day.

1.9 DELIVERY, STORAGE AND HANDLING

- A. Deliver material to the site in the Manufacturer's original and unopened packaging, with intact and legible labels which identify the products and Manufacturers,
- B. Cover all stored materials, except rolls of EPDM and sealed cans of adhesives, with watertight tarpaulins installed immediately upon delivery.
- C. Immediately remove insulation which gets wet from the job site.
- D. Store and install all material within the Manufacturer's recommended temperature range.
- E. Do not overload the structure when storing materials on the roof.

- F. Protect roof surfaces where material and equipment is placed on them, and where construction traffic occurs, with 6 mil fire retardant polyethylene, covered with 1-1/2 inch thick foam insulation, overlaid with 2 by 10 wooden planks.

1.10 GUARANTEE AND WARRANTY

- A. Provide a written Manufacturer's Full System Warranty which warrants that the roofing system, including the thermal barrier, vapor barrier, insulation, cover board, EPDM roofing and flashings, will remain in a watertight condition for a twenty year period beginning upon Final Completion.
 - 1. Guarantee coverage shall remain in effect for gust wind speeds up to 72 miles per hour, measured at ground level at the site.
 - 2. Guarantee coverage shall have no dollar value limit.
- B. Provide a written Contractor's Guarantee which guaranties that all work will remain free of material and workmanship defects and in a watertight condition for a five year period beginning upon Final Completion:
 - 1. Defects include but are not limited to the following: leakage, adhesive separation, delamination, lifting, loosening, splitting, cracking, joint separation, movement and undue expansion or shrinkage.
 - 2. The Contractor shall make the repairs and modifications necessary to enable the work to perform as guaranteed at his own expense:
 - 3. Guarantee coverage shall include removing and replacing materials installed as part of the original work, if removal is needed to affect guaranteed repairs.
 - 4. Guarantee coverage shall remain in effect for gust wind speeds up to 72 miles per hour, measured at ground level at the site.
 - 5. Guarantee coverage shall have no dollar value limit.
- C. Provide one Contractor's Guarantee that covers "all work performed" when a single contractor is awarded work specified in multiple Sections.
- D. The Manufacturer's Warranty and Contractors Guarantee shall take effect no more than 30 days before the completion of all punch list work.
- E. The Contractor's Surety Company may add a rider to the Performance Bond which clarifies that Performance Bond Coverage expires two years after Final Completion; i.e., Performance Bond Coverage does not run for the entire five year term of the Contractor's Guarantee.
- F. Guarantee and Warranty coverage may be cancelled, for the affected portion of the roof, if the work is damaged by winds in excess of 72 mph, by hail, lightning, insects or animals, by failure of the structural substrate, by exposure to harmful chemicals, by other trades on the roof, or by vandalism, or if the Owner fails to maintain the roof in

accordance with, or makes roof alterations contrary to, the Manufacturer's printed recommendations.

1. Guarantee and Warranty coverage shall be reinstated, for the remainder of the original period; if the Owner restores the roof to the condition it was in prior to the damage occurring.

1.11 SUBSTITUTIONS

- A. The following factors will be considered when evaluating a possible alternative to the roofing system specified:
1. The wording and intent of the warranty to be issued.
 2. The financial status, numbers of years in business, and stability of the entity that will issue the warranty.
 3. A reference list of at least five completed similar projects of comparable size, with a successful functional history of at least five years, within an approximate fifty mile radius of the Project.
 4. Technical aspects of the system, especially relating to durability, serviceability and performance.
 5. The Manufacturer's ability and history providing technical support, on-site inspections and in progress assistance.
 6. The availability and experience of local authorized applicators to install and maintain the proposed alternate system.
 7. The Manufacturer's willingness and history responding to warranty claims previously made by the Owner, Architect or Consultant's involved in this project.

PART 2 - PRODUCTS

2.1 GENERAL

- A. EPDM roof system components are specified as products of Firestone Building Products Company to establish a standard of quality. Equal products and systems from Carlisle SynTec and Johns Manville will be accepted.
- B. Primary products required for this project include:
1. Vapor barrier
 2. Thermal barrier
 3. Roof insulation
 4. Cover board
 5. EPDM roofing
 6. Primers and adhesives
 7. Sealants
 8. EPDM flashing
 9. Fasteners

10. Acrylic coating

2.2 EPDM

1. Unreinforced 60 mils thick, fire retardant, EPDM (Ethylene Propylene Diene Monomer) sheet membrane conforming to the following minimum physical properties.

PROPERTY	TEST METHOD	SPECIFICATION
Color	—	Gray/Black
Tensile Strength	ASTM D-412	1305 psi min.
Elongation	ASTM D-412	300% min
Tear Strength	ASTM D-624	150 lb/in min
Ozone Resistance	ASTM D-1149	No cracks, 7 days/100 pphm/100°F/50% strain
Heat Aging	ASTM D-573	1200 psi min@ 200% elongation/4 wks/240°F
Brittleness Temperature	ASTM D-746	-49°F
Water Vapor Permanence	ASTM E-96	2.0 perm max
Thickness	ASTM D-412	60 mils plus/minus 6 mils
Fire Retardant		UL Class A

2.3 RELATED MATERIALS

- A. Cleaners, adhesives, sealants, caulking and fasteners furnished by the EPDM system Manufacturer, that comply with low VOC regulations in effect at the time of application.
 1. Stripping: 90 mil thick 5 inch and 9 inch wide self adhering flashing, consisting of 45 mils of semi-cured EPDM factory laminated to 45 mils of cured seaming tape.
 2. Bonding Adhesive: High strength contact adhesive.
 3. Splice Adhesive: High strength synthetic polymer based contact cement formulated specifically to splice EPDM sheets.
 4. Lap Sealant: EPDM rubber based gun grade sealant.
 5. Water Block Seal: One component low viscosity butyl rubber sealant.
 6. Pre-Molded Pipe Flashing: Pressure sensitive prefabricated flashings with pre-applied adhesive.
 7. Pourable Sealer: Two component, solvent free polyurethane based sealant.
 8. Reinforced Perimeter Fastening Strips: .030 inch thick reinforced cured EPDM.
 9. Seam Tape Primer: Synthetic rubber polymer based primer designed to clean and prime seam tape splice areas prior to installing the tape.
 10. Seam Splice Tape: Nominal 30 mil thick cured polymer self adhesive tape with release paper carrier, 6 inches wide.

11. Plates and Bars: Galvanized and corrosion resistant specialty products.
 12. Fasteners: #14 Fluorocarbon polymer coated heavy duty screws.
- B. Primer & Vapor Barrier:
1. Primer: Thin, cut back asphalt meeting ASTM D41.
 2. Vapor Barrier: Fire resistant torch grade SBS modified granular surfaced polyester and glass scrim reinforced cap sheet meeting ASTM D 6163 Type I, Grade G, furnished by the same manufacturer as the EPDM.
- C. Gypsum Thermal Barrier and Cover Board: 1/2 inch thick fire resistant gypsum board decking with inorganic glass mat facers and a water resistant core, formulated in 48 x 48 inch square edge boards, UL Class A, meeting ASTM C-1177, manufactured under the trade name Dens-Deck Prime.
- D. Insulation: Flat and tapered rigid cellular polyisocyanurate boards with fibrous felt/fiberglass mat facers, minimum compressive strength 20 psi, meeting ASTM C1289-01, Type II, Class1, Grade 2, as manufactured by Firestone under the trade name of "ISO 95+ Isocyanurate Insulation".
1. Install 2 layers of 3 inch thick insulation (6 inches total) on deck surfaces that have structural slope.
 2. Install tapered insulation that slopes 1/4 inch per foot (minimum starting thickness 6 inches) on deck surface that are flat - without structural slope.
 3. Install crickets that sloped 1/2 inch per foot.
- E. Tapered edge strips – high density isocyanurate or wood fiberboard strips installed at the drain sumps, and insulation transition points.
- F. Insulation adhesive: Two component low rise polyurethane foam adhesive, installed with a mixing extruding Pace Cart dispenser, or with a pleural heated foam rig, Firestone I.S.O. Adhesive.
1. Use insulation adhesive suitable for application at the intended application temperatures.
 2. Do not use twin cartridge "caulking gun" adhesive except on very small isolated sections of roof.
- G. Acrylic Color Coating: Latex based acrylic coating containing 67% solids by weight, resistant to heat, cold water, ozone, ultraviolet rays, and intended for installation on weathered EPDM. Custom color tint as selected by the Architect.

PART 3 - EXECUTION

3.1 GENERAL

- A. Install the new roofing system in a watertight, workmanlike manner, meeting the guarantee requirements specified herein; in accordance with the drawings and in conformance with the Manufacturer's requirements, except as enhanced by the drawings and specifications.

- B. Perform work next to roof mounted mechanical equipment, so the work coincides with equipment shutdown periods and so fumes do not enter the building or affect building occupants. Temporarily cover and protect equipment openings, and windows next to the work area, with 6 mil fire retardant polyethylene, so dirt, dust and odors do not enter the equipment or building. Remove covers as soon as the work is complete and at the end of each workday.
- C. Clean substrate surfaces of all laitance, dirt, oil, grease or other foreign matter before any roofing is installed.
- D. Remove debris daily and as it is generated. Do not stock-pile debris on the roof. Do not leave any debris on the roof at the end of the day. Do not overload the roof structure when moving debris.
- E. Install roof system components on dry surfaces only. Do not install any components when the weather and outside temperatures are not suitable in accordance with the Manufacturer's recommendations.
- F. Complete all work including the equipment flashings, in sequence as quickly as possible so the smallest area possible is under construction at any one time. Complete the entire area of work begun each day, the same day, and make all exposed edges watertight at the end of each day's work.
- G. Protect roof surfaces where material and equipment is placed on them, and where construction traffic occurs, with 6 mil fire retardant polyethylene, covered with 1-1/2 inch thick foam insulation, overlaid with 2 by 10 wooden planks.

3.2 VAPOR BARRIER CONCRETE DECKS

- A. Install primer and a vapor barrier on the concrete decks: install the primer and allow it to dry.
- B. Starting at the low point, torch apply and fully adhere modified bitumen vapor barrier sheets to the primed substrate. Lap sheets at least 4 inches at the ply overlaps and at least 6 inches at the end laps.
- C. Carefully install the vapor barrier sheets to achieve only the minimum required bleed out.
- D. Extend vapor barrier up vertical surfaces at the roof perimeter, and up and around all penetrations and curbs, and seal the vapor barrier to provide continuity of the building air/vapor envelope.

3.3 GYPSUM BOARD THERMAL BARRIER

- A. Install gypsum board over all other deck areas. Lay boards with tight joints. Fill spaces over 1/4 inch.

3.4 INSULATION

- A. Install tapered insulation neatly cut at all miters and transitions. Do not lace corner boards.
 - B. Install insulation with joints offset between rows and layers a minimum of 12 inches. Cut insulation to fit neatly at penetrations and joints. Fill any gap which is greater than 1/4 inch.
 - C. Fasten the gypsum board thermal barrier and all layers of insulation only to the top flute of steel decks, with screws and discs which penetrate through the deck a minimum of 3/4 inch and a maximum of 1-1/2 inches.
 - 1. Install 16 fasteners per 4 by 8 foot insulation board in the field of the roof.
 - 2. Install 28 fasteners per 4 by 8 foot insulation board in 8 foot wide perimeter zones.
 - 3. Install 32 fasteners per 4 by 8 foot insulation board in 8 foot square corner zones.
 - 4. Carefully choose the length and position of each screw to ensure the screws do not protrude through the underside of the deck where visible inside the school, and to ensure the screws do not damage conduits mounted on the underside of the deck.
 - 5. Perform pull tests using the intended fasteners, on each roof area before beginning work, and obtain the Manufacturer's written approval of the fastener that will be used.
 - D. On concrete deck areas install all layers of insulation using low rise polyurethane foam adhesive applied in accordance with the Manufacturer's recommendations and to achieve the specified minimum uplift resistance. Offset joints in the insulation between rows and layers a minimum of 12 inches. Cut insulation to fit neatly at penetrations and joints. Fill any gap which is greater than 1/4 inch.
 - 1. Install 1/2 inch diameter adhesive beads 12 inches on center in the field of the roof.
 - 2. Install 1/2 inch diameter adhesive beads 6 inches on center in 8 foot wide perimeter zones.
 - 3. Install 1/2 inch diameter adhesive beads 4 inches on center in 8 foot square corner zones.
 - 4. Place 5 gallon pails half full of gravel or concrete on the insulation and gypsum cover boards to hold them firmly in position for at least 15 minutes while the low rise foam adhesive sets. Position the pails no more than 24 inches apart in all directions.
 - a. **Insulation installed without using pails of concrete or gravel shall be removed and replaced.**
- 3.5 COVER BOARD
- A. Install the cover board neatly cut at all miters and transitions. Do not lace corner boards.
 - B. Install the cover board with joints offset between rows and layers a minimum of 12 inches. Cut the cover board to fit neatly at penetrations and joints. Fill any gap which is greater than 1/4 inch.
 - C. Install the cover board using low rise foam adhesive.
 - 1. Install 1/2 inch diameter adhesive beads 12 inches on center in the field of the roof.

2. Install 1/2 inch diameter adhesive beads 6 inches on center in 8 foot wide perimeter zones.
 3. Install 1/2 inch diameter adhesive beads 4 inches on center in 8 foot square corner zones.
- D. Place 5 gallon pails half full of gravel or concrete on the insulation and gypsum cover boards to hold them firmly in position for at least 15 minutes while the low rise foam adhesive sets. Position the pails no more than 24 inches apart in all directions.
1. **Cover boards installed without using pails of concrete or gravel shall be removed and replaced.**

3.6 EPDM

- A. Place EPDM roofing on the substrate without stretching it, and allow it to relax approximately one hour – before starting to adhere it to the substrate and form the seams.
- B. Place adjoining sheets in the same manner lapping the edges to shed water.
- C. Fully adhere EPDM to the substrate with bonding adhesive.
 1. Open each can of adhesive and stir it with an electric paddle mixer for at least 5 minutes before applying the adhesive. Re-stir adhesive that isn't used within two hours of initial mixing.
 2. Do not punch holes in cans of adhesive and use them in a "Better Spreader" without first opening the cans to mix them.
 3. Replace used roller covers each day; discard covers after each days use.
 4. Allow bonding adhesive to dry to the touch before joining the EPDM to the substrate.
 5. Roll the EPDM onto the dried bonding adhesive and immediately rub it vigorously with a soft bristle broom to ensure complete adhesion.
- D. EPDM installed over improperly applied adhesive or with adhesive that wasn't stirred, and roofing installed with blisters, ridges, mole runs and similar deficiencies shall be removed and replaced. Removal shall include the insulation and cover board assembly.

3.7 SPLICING

- A. Form EPDM roof splices with 6 inch wide field applied seam tape, or with 3 inch wide factory applied seam tape.
 1. Fold the top sheet back and clean mating surfaces using clean rags with splice wash.

2. Scrub a smooth coat of QuickPrime onto mating surfaces, with long strokes, and to obtain complete coverage, using approximately 1 gallon per 225 square feet. Do not allow the QuickPrime to glop, streak or puddle; allow it to dry to the touch before installing the seam tape.
 3. Seam tape shall be positioned so 1/8 inch minimum and 1/2 inch maximum will be exposed at the seam edge when the seam is complete.
 - a. Install 5 inch uncured EPDM stripping over any seam where the tape is exposed less than 1/8 inch or more than 1/2 inch.
 4. Roll and allow the top sheet to fall freely into place without stretching or wrinkling it.
 5. Pull splice tape release paper from within the seam and neatly mate the seam using hand pressure to rub the membrane together.
 6. Immediately roll the splice with a 2 inch wide roller, using positive pressure, toward the outer edge of splice.
- B. Install uncured EPDM target patches with rounded corners, over all T-Seam intersections.

3.8 PERIMETER FASTENING

- A. Secure the EPDM at the perimeter of each roof level, and at eaves, penetrations, expansion joints and slope changes greater than 1 inch in 12 inches. Utilize surface applied discs or adhere the EPDM to continuous reinforced EPDM fastening strips. Secure the discs and EPDM fastening strips 12 inches on center.

3.9 FLASHINGS

- A. Utilized cured EPDM for all flashings; utilize self-curing EPDM at corners and angle changes only where required by the Manufacturer.
1. Form flashing splices, and the splice between the flashing and main roof sheet with 6 inch seam tape.
 2. Adhere the flashing to vertical surfaces with bonding adhesive.
 3. Fasten the top edge of all flashings, positioning the fasteners 12 inches on center, to be covered by a cap flashing.
- B. Install premolded pipe flashings wherever possible. Where premolded pipe flashings cannot be installed, use field wrapped flashings. Install sealant pockets as a last resort.
- C. Remove existing pipe flashings and Kennedy type couplings and extend the vent pipes to finish a minimum of 18 inches above the roof surface.
1. Extend the pipes using the same type of pipe material as the original vent pipe.

2. Use threaded or no-hub couplings, positioned within the insulation layer to extend the pipes.

3.10 DUCT WRAP WATERPROOFING & COATING:

- A. Cover all roof top ductwork with isocyanurate insulation and fully adhered 60 mil thick EPDM roofing.
 1. Install EPDM cover strips and target patches to seal all duct air leaks before recovering them.
 2. Install flat 3 inch thick insulation on the sides and bottom of the ducts.
 3. Install tapered insulation sloping 1/4 inch per foot, minimum-starting thickness 3 inches on top of the ducts.
 4. Secure the isocyanurate insulation with screws and plates, installed at the rate of one fastener per 2 square feet.
 5. Cover the insulation with fully adhered 60 mil fire retardant EPDM.
 6. Install two roller applied coats of acrylic color coating on the EPDM duct cover.

3.11 MISCELLANEOUS

- A. Provide any miscellaneous roofing, flashing, caulking, and metal work needed to leave the work complete and entirely watertight, neatly and carefully executed in a thorough and workmanlike manner.
- B. Use mechanics skilled and licensed in the trades to perform mechanical and electrical work. Provide new material, couplings, transition pieces, blocking, fasteners and the like needed to complete the work.

3.12 CLEANING, PROTECTION AND WATERTIGHTNESS

- A. Provide any equipment, material and labor necessary to protect the site, the building, its contents and occupants, pedestrians, and surrounding landscaped and paved areas from damage due to the construction work or from inclement weather during construction.
- B. Do not perform work during inclement weather. Protect incomplete work and the building from damage by inclement weather - which may occur unexpectedly. Make all work areas watertight at the end of each day's work.
- C. Clean up all litter, refuse, rubbish, scrap materials and debris at least twice a day; at noon and at the end of the work day, so the roof and site presents a neat, orderly and workmanlike appearance. Place the debris in a dumpster, and remove the dumpster from the site as soon as it is full or no longer being used.

- D. Carefully and thoroughly clean the entire roof to remove all residual debris when all work is complete. After cleaning the roof, thoroughly clean all drain sumps, drain lines, leader heads and leaders. Do not allow debris to enter the drainage system.

3.13 ROOF INSPECTIONS BY MANUFACTURER

- A. Arrange for the roofing Manufacturer, or his authorized representative, to make a minimum of five inspections in accordance with the following schedule and submit a written report of each inspection to the Architect.
 - 1. First inspection during the first two days of new roof installation.
 - 2. Second inspection when roofing is approximately one third complete.
 - 3. Third inspection when roofing is approximately two thirds complete.
 - 4. Fourth inspection when all roofing and flashings are installed.
 - 5. Final inspection at the completion of all work.
- B. Provide 48 hours advance written notice to the Architect, so he may have a representative attend the inspections.
- C. Submit the inspection reports within one week following each inspection.
 - 1. Payment requisitions will not be reviewed nor approved until the inspection reports are received.

3.14 WASTE MANAGEMENT – Coordinate with Section 017419

- A. Separate and recycle materials and material packaging in accordance with Waste Management Plan and to the maximum extent economically feasible and place in designated areas for recycling.
- B. Set aside and protect materials suitable for reuse and/or remanufacturing.
- C. Separate and fold up metal banding; flatten and place along with other metal scrap for recycling in designated area.

END OF SECTION

SECTION 076200 - SHEET METAL FLASHING, FABRICATIONS AND TRIM

PART 1 - GENERAL

1.1 SUMMARY

A. This Section includes sheet metal flashing and trim in the following categories:

1. Metal flashing.
2. Reglets.
3. Scuppers.
4. Downspouts and conductor heads.
5. Downspout boots
6. Metal trim.

B. Related Work Specified elsewhere:

1. Zinc sheet metal siding, flashing, trim and fabrications are specified in Division 07 Section "Sheet Metal Siding."
2. Aluminum composite copings/cornice fabrications are specified in Division 07 Section "Composite Metal Wall and Soffit Panels."

1.2 PERFORMANCE REQUIREMENTS

A. General: Sheet metal flashing and trim assemblies as indicated shall withstand wind loads, structural movement, thermally induced movement, and exposure to weather without failure due to defective manufacture, fabrication, installation, or other defects in construction. Completed sheet metal flashing and trim shall not rattle, leak, or loosen, and shall remain watertight.

B. Low-slope membrane roof system metal edge securement, except gutters, shall be designed and installed for wind loads in accordance with Building Code of NY, Chapter 16 and tested for resistance in accordance with ANSI/SPRI ES-1.

1. Fabricate and install roof edge flashing, metal edge securement, facae and copings capable of resisting the following forces:
 - a. Wind Zone 2 (roof edge perimeter, vertical load direction): As indicated on Structural Drawings.
 - b. Wind Zone 3 (roof edge corners, vertical load direction): As indicated on Structural Drawings.
 - c. Wind Zone 4 (wall edge perimeter, horizontal load direction): As indicated on Structural Drawings.
 - d. Wind Zone 5 (wall edge corners, horizontal load direction): As indicated on Structural Drawings.
2. Dimension of perimeter and corner zones shall be as indicated on Structural Drawings.

- C. Thermal Movements: Provide sheet metal flashing and trim that allows for thermal movements from ambient and surface temperature changes.
 - 1. Temperature Change (Range): 120 deg F (67 deg C), ambient; 180 deg F (100 deg C), material surfaces

1.3 ACTION SUBMITTALS

- A. Product Data including manufacturer's material and finish data, installation instructions, and general recommendations for each specified flashing material and fabricated product.
- B. Shop Drawings of each item specified showing layout, profiles, methods of joining, and anchorage details.
- C. Samples for Verification: Samples of sheet metal flashing, trim, and accessory items, in the specified finish. Where finish involves normal color and texture variations, include Sample sets composed of 2 or more units showing the full range of variations expected.
 - 1. 8-inch- (200-mm-) square Samples of specified sheet materials to be exposed as finished surfaces.
 - 2. 12-inch- (300-mm-) long samples of factory-fabricated products exposed as finished Work and accessories, as specified below.
 - a. Dowspouts.

1.4 INFORMATIONAL SUBMITTALS

- A. Qualification data for firms and persons specified in the "Quality Assurance" Article to demonstrate their capabilities and experience. Include lists of completed projects with project names and addresses, names and addresses of architects and owners, and other information specified.
- B. Product Test Reports: Based on evaluation of comprehensive tests performed by a qualified testing agency, for copings and roof-edge flashings.
- C. Warranty: Sample of special warranty.

1.5 QUALITY ASSURANCE

- A. Installer Qualifications: Engage an experience Installer who has completed sheet metal flashing and trim work similar in material, design, and extent to that indicated for this Project and with a record of successful in-service performance.
- B. Sheet Metal Flashing and Trim Standard: Comply with SMACNA's "Architectural Sheet Metal Manual." Conform to dimensions and profiles shown unless more stringent requirements are indicated.

1.6 PROJECT CONDITIONS

- A. Coordinate Work of this Section with interfacing and adjoining Work for proper sequencing of each installation. Ensure best possible weather resistance, durability of Work, and protection of materials and finishes.

1.7 WARRANTY

- A. Special Warranty on Painted Finishes: Manufacturer's standard form in which manufacturer agrees to repair finish or replace roof specialties that show evidence of deterioration of factory-applied finishes within specified warranty period.
 - 1. Fluoropolymer Finish: Deterioration includes, but is not limited to, the following:
 - a. Color fading more than 5 Hunter units when tested according to ASTM D 2244.
 - b. Chalking in excess of a No. 8 rating when tested according to ASTM D 4214.
 - c. Cracking, checking, peeling, or failure of paint to adhere to bare metal.
 - 2. Finish Warranty Period: 20 years from date of Substantial Completion.
- B. Performance Warranty: Include copings, fasciae and roof edge flashings in Total System Warranty provided by roofing membrane manufacturer; refer to Section 075323.

PART 2 - PRODUCTS

2.1 METALS

- A. Aluminum: Alloy and temper recommended by aluminum producer and finisher for type of use and finish indicated and with not less than the strength and durability of alloy and temper designated below:
 - 1. Aluminum Sheet: ASTM B 209, Alclad 3003-H14, with a minimum thickness as indicated.
 - 2. Extruded Aluminum: ASTM B 221, alloy 6063-T52, with a minimum thickness of 0.080 inch for primary legs of extrusions, unless otherwise indicated.
- B. Stainless Steel: ASTM 240/A 240M, Type 304 sheet.

2.2 MISCELLANEOUS MATERIALS AND ACCESSORIES

- A. Fasteners: Same metal as sheet metal flashing or other noncorrosive metal as recommended by sheet metal manufacturer. Match finish of exposed heads with material being fastened.
- B. Asphalt Mastic: SSPC-Paint 12, solvent-type asphalt mastic, nominally free of sulfur and containing no asbestos fibers, compounded for 15-mil (0.4-mm) dry film thickness per coat.
- C. Mastic Sealant: Polyisobutylene; nonhardening, nonskinning, nondrying, nonmigrating sealant.

- D. Elastomeric Sealant: Generic type recommended by sheet metal manufacturer and fabricator of components being sealed and complying with requirements for joint sealants as specified in Division 07 Section "Joint Sealants."
- E. Epoxy Seam Sealer: 2-part, noncorrosive, aluminum seam-cementing compound, recommended by aluminum manufacturer for exterior and interior nonmoving joints, including riveted joints.
- F. Adhesives: Type recommended by flashing sheet metal manufacturer for waterproof and weather-resistant seaming and adhesive application of flashing sheet metal.
- G. Felt Underlayment: ASTM D 226, Type II (No. 30), asphalt-saturated organic felt, nonperforated.
- H. Slip Sheet: 3-lb. rosin-sized building paper or Tyvek by DuPont.
- I. Self-Adhering Sheet Underlayment, Polyethylene Faced: ASTM D 1970, minimum of 40 mils (1.0 mm) thick; slip-resisting, polyethylene-film-reinforced top surface laminated to SBS-modified asphalt adhesive, with release-paper backing; cold applied. Provide primer when recommended by underlayment manufacturer.
 - 1. Product: Ice and Water Shield by GCP Applied Technologies.or equal.
- J. Metal Accessories: Provide sheet metal clips, straps, anchoring devices, and similar accessory units as required for installation of Work, matching or compatible with material being installed; noncorrosive; size and thickness required for performance.
- K. Roofing Cement: ASTM D 4586, Type I, asbestos free, asphalt based.
- L. Cast Iron Downspout Boots: Size as indicted on Drawings, by JR Hoe,or equal.

2.3 MANUFACTURED SHEET METAL FLASHING AND TRIM

- A. General: Provide items designed and fabricated to fit applications indicated and to perform optimally with respect to weather resistance, water tightness, durability, strength, and uniform appearance.
- B. Expansion Provisions: Fabricate running lengths to allow controlled expansion not only for movement of metal components in relationship to one another but also to adjoining dissimilar materials, including flashing and roofing membrane materials, in a manner sufficient to prevent water leakage, deformation or damage.
- C. Reglets: Units of type, material, and profile indicated, formed to provide secure interlocking of separate reglet and counterflashing pieces and compatible with flashing indicated.
 - 1. Surface-Mounted Type: Provide with slotted holes for fastening to substrate, with neoprene or other suitable weatherproofing washers, and with channel for sealant at top edge.

2. Concrete Type: Provide temporary closure tape to keep reglet free of concrete materials, special fasteners for attaching reglet to concrete forms, and guides to ensure alignment of reglet section ends.
3. Masonry Type: Provide with offset top flange for embedment in masonry mortar joint.
4. Flexible Flashing Retainer: Provide resilient plastic or rubber accessory to secure flexible flashing in reglet where clearance does not permit use of standard metal counterflashing or where Drawings show reglet without metal counterflashing.
5. Counterflashing Wind-Restraint Clips: Provide clips to be installed before counterflashing to prevent wind uplift of the counterflashing lower edge.
6. Material: Fabricate reglets from the following metal, in thickness indicated:
 - a. Stainless steel, 0.020 inch thick.
7. Manufacturers: Subject to compliance with requirements, provide products by one of the following:
 - a. Fry Reglet Corporation.
 - b. Metal-Era Inc
 - c. OMG, Inc.

2.4 FABRICATION, GENERAL

- A. General Metal Fabrication: Shop-fabricate work to greatest extent possible. Comply with details shown and with applicable requirements of SMACNA "Architectural Sheet Metal Manual" and other recognized industry practices. Fabricate for waterproof and weather-resistant performance, with expansion provisions for running work, sufficient to permanently prevent leakage, damage, or deterioration of the work. Form work to fit substrates. Comply with material manufacturer instructions and recommendations for forming material. Form exposed sheet metal work without excessive oil-canning, buckling, and tool marks, true to line and levels indicated, with exposed edges folded back to form hems.
- B. Seams in Aluminum: Fabricate nonmoving seams in aluminum with flat-lock seams. Form seams and seal with epoxy seam sealer. Rivet joints for additional strength.
- C. Expansion Provisions: Space movement joints at maximum of 10 feet with no joints allowed within 24 inches (600 mm)of corner or intersection. Where lapped or bayonet-type expansion provisions in Work cannot be used or would not be sufficiently weatherproof and waterproof, form expansion joints of intermeshing hooked flanges, not less than 1 inch (25.4 mm) deep, filled with mastic sealant (concealed within joints.)
- D. Sealed Joints: Form nonexpansion, but movable, joints in metal to accommodate elastomeric sealant to comply with SMACNA standards.
- E. Separate metal from noncompatible metal or corrosive substrates by coating concealed surfaces at locations of contact with asphalt mastic or other permanent separation as recommended by manufacturer.
- F. Conceal fasteners and expansion provisions unless noted otherwise. Exposed fasteners are not allowed on faces of sheet metal exposed to public view.

- G. Fabricate cleats and attachment devices from same material as sheet metal component being anchored or from compatible, noncorrosive metal recommended by sheet metal manufacturer.
 - 1. Size: As recommended by SMACNA manual or sheet metal manufacturer for application but never less than thickness of metal being secured.
- H. Scuppers: Fabricate scuppers of dimensions required with closure flange trim to exterior, 4-inch- (100-mm-) wide wall flanges to interior, and base extending 4 inches (100 mm) beyond cant or tapered strip into field of roof.
- I. Downspouts: Fabricate rectangular downspouts complete with mitered elbows. Furnish with metal hangers, from same material as downspouts, and anchors.
 - 1. Metal Material: Aluminum.
 - 2. Metal Thickness: 0.024" min.
 - 3. Size: As indicated on Drawings.
 - 4. Finish: Fluoropolymer 2-Coat System, color as selected by Architect.

2.5 SHEET METAL FABRICATIONS

- A. General: Fabricate sheet metal items in thickness or weight needed to comply with performance requirements but not less than that listed below for each application and metal.
- B. Miscellaneous Exposed Trim, Scuppers, Base Flashing, Conductor Head: Fabricate from the following material (where indicated on Drawings):
 - 1. Aluminum: 0.040 inch (1 mm) thick
 - 2. Stainless Steel: 24 gauge
- C. Counterflashing, Flashing Receivers: Fabricate from the following material (where indicated on Drawings):
 - 1. Aluminum: 0.032 inch (0.813 mm) thick
 - 2. Stainless Steel: 26 gauge

2.6 ALUMINUM FINISHES

- A. General: Comply with Aluminum Association's (AA) "Designation System for Aluminum Finishes" for finish designations and application recommendations.
- B. High-Performance Organic Finish: AA-C12C42R1x (Chemical Finish: cleaned with inhibited chemicals; Chemical Finish: acid-chromate-fluoride-phosphate conversion coating; Organic Coating: as specified below). Prepare, pretreat, and apply coating to exposed metal surfaces to comply with coating and resin manufacturers' written instructions.
 - 1. Fluoropolymer 2-Coat System: Manufacturer's standard 2-coat thermocured system consisting of specially formulated inhibitive primer and fluoropolymer color

- topcoat containing not less than 70 percent polyvinylidene fluoride resin by weight; complying with AAMA 2605.
- 2. Colors: As selected by Architect for each location.

PART 3 - EXECUTION

3.1 EXAMINATION

- A. Examine substrates and conditions under which sheet metal flashing and trim are to be installed and verify that Work may properly commence. Do not proceed with installation until unsatisfactory conditions have been corrected.

3.2 INSTALLATION

- A. General: Unless otherwise indicated, install sheet metal flashing and trim to comply with performance requirements, manufacturer's installation instructions, and SMACNA's "Architectural Sheet Metal Manual." Anchor units of Work securely in place by methods indicated, providing for thermal expansion of metal units; conceal fasteners where possible, and set units true to line and level as indicated. Install Work with laps, joints, and seams that will be permanently watertight and weatherproof.
- B. Install exposed sheet metal Work that is without excessive oil canning, buckling, and tool marks and that is true to line and levels indicated, with exposed edges folded back to form hems. Install sheet metal flashing and trim to fit substrates and to result in waterproof and weather-resistant performance. Verify shapes and dimensions of surfaces to be covered before fabricating sheet metal.
- C. Roof-Edge Flashings and Edge Securement: Secure metal flashings, copings and edge securement at roof edges according to Building Code of NY, Chapter 16 for specified wind zone.
- D. Isolation: Where metal surfaces of units are installed in contact with dissimilar metal or corrosive substrates, including wood, apply bituminous coating on concealed metal surfaces, or provide other permanent separation as recommended by sheet metal producer.
- E. Expansion Provisions: Provide for thermal expansion of exposed sheet metal Work. Space movement joints at maximum of 10 feet with no joints allowed within 24 inches of corner or intersection. Where lapped or bayonet-type expansion provisions in Work cannot be used or would not be sufficiently weatherproof and waterproof, form expansion joints of intermeshing hooked flanges, not less than 1 inch deep, filled with mastic sealant (concealed within joints).
- F. Sealed Joints: Form nonexpansion, but movable, joints in aluminum to accommodate elastomeric sealant to comply with SMACNA standards. Fill joint with sealant and form metal to completely conceal sealant.
 - 1. Use joint adhesive for nonmoving joints specified not to be soldered.

- G. Seams in Aluminum: Fabricate nonmoving seams in aluminum with flat-lock seams. Form seams and seal with epoxy seam sealer. Rivet joints for additional strength.
- H. Separations: Separate metal from noncompatible metal or corrosive substrates by coating concealed surfaces, at locations of contact, with asphalt mastic or other permanent separation as recommended by manufacturer.
 - 1. Underlayment: Where installing copper or aluminum directly on cementitious or wood substrates, install a slip sheet of red-rosin paper over one layer of felt underlayment before installing sheet metal.
 - 2. Bed flanges in a thick coat of roofing cement where required for waterproof performance.
- I. Install reglets to receive counterflashing according to the following requirements:
 - 1. Where reglets are shown in concrete, furnish reglets for installation under Division 03 Section "Cast-in-Place Concrete."
 - 2. Where reglets are shown in masonry, furnish reglets for installation under Division 04 Sections.
- J. Counterflashings: Coordinate installation of counterflashings with installation of assemblies to be protected by counterflashing. Install counterflashings in reglets or receivers. Secure in a waterproof manner by means of snap-in installation and sealant, lead wedges and sealant, interlocking folded seam, or blind rivets and sealant. Lap counterflashing joints a minimum of 2 inches (50 mm) and bed with sealant.
- K. Fascia and Copings: Install cleats, anchor plates, and other anchoring and attachment accessories and devices with concealed fasteners. Anchor fasciae and copings to meet performance requirements.

3.3 CLEANING AND PROTECTION

- A. Clean exposed metal surfaces, removing substances that might cause corrosion of metal or deterioration of finishes.
- B. Provide final protection and maintain conditions that ensure sheet metal flashing and trim Work during construction is without damage or deterioration other than natural weathering at the time of Substantial Completion.

END OF SECTION 076200

SECTION 076223 - SHEET METAL SIDING

PART 1 - GENERAL

1.1 SUMMARY

A. This Section includes the following:

1. Zinc flat lock tile wall cladding system.
2. Zinc reveal flat panels wall cladding system.
3. Zinc coping, soffits and wall trim
4. Zinc wall cladding accessories including closures, fasteners and clips, corners, flashings, and other components of wall panel system; include all required accessories for a weatherproof installation.
5. Weather membrane and metal deck directly behind zinc cladding.
6. Wall panel stub framing system and panel stiffeners with foam tape.
 - a. Subframing required to support the composite core wall panel profiles indicated on the Drawings shall be part of the system designed under this Section.

B. Related Sections include the following:

1. Division 07 Section "Sheet Metal Flashing and Trim" for flashing, rain drainage units, copings and fascia.

1.2 PERFORMANCE REQUIREMENTS

A. General: Sheet metal flashing and trim assemblies as indicated shall withstand wind loads, structural movement, thermally induced movement, and exposure to weather without failure due to defective manufacture, fabrication, installation, or other defects in construction. Completed sheet metal flashing and trim shall not rattle, leak, or loosen, and shall remain watertight.

B. Low-slope membrane roof system metal edge securement, except gutters, shall be designed and installed for wind loads in accordance with Building Code of NY, Chapter 16 and tested for resistance in accordance with ANSI/SPRI ES-1.

1. Fabricate and install roof edge flashing, metal edge securement, facae and copings capable of resisting the following forces:
 - a. Wind Zone 2 (roof edge perimeter, vertical load direction): As indicated on Structural Drawings.
 - b. Wind Zone 3 (roof edge corners, vertical load direction): As indicated on Structural Drawings.
 - c. Wind Zone 4 (wall edge perimeter, horizontal load direction): As indicated on Structural Drawings.

- d. Wind Zone 5 (wall edge corners, horizontal load direction): As indicated on Structural Drawings.
2. Dimension of perimeter and corner zones shall be as indicated on Structural Drawings.
- C. Vertical and Lateral Fire Propagation Test Characteristics: The exterior wall assembly of the School Building is required to comply with NFPA 285 "Standard Method of Test for the Evaluation of Flammability Characteristics of Exterior Nonload-bearing Wall Assemblies Containing Combustible Components." The base wall, stud cavity insulation, wall sheathing, air barrier, continuous wall rigid insulation and exterior cladding are components that are required to be to be evaluated as part of this specific assembly test. Metal wall and soffit panels shall be part of an assembly that has passed NFPA 285 testing.
- D. Thermal Movements: Provide sheet metal flashing and trim that allows for thermal movements from ambient and surface temperature changes.
 1. Temperature Change (Range): 120 deg F (67 deg C), ambient; 180 deg F (100 deg C), material surfaces
- E. Structural Performance: Metal wall panel assemblies shall withstand the effects the following loads and stresses within limits and under conditions indicated, based on testing according to ASTM E 330:
 1. Wind Loads: Determine loads based on the following minimum design wind pressures:
 - a. Uniform pressure as indicated on Structural Drawings.
 2. Secondary Framing: Design secondary framing system according to AISI "Standard for Cold-Formed Steel Framing - General Provisions."

1.3 ACTION SUBMITTALS

- A. Product Data: For each product indicated. Include details of construction relative to materials, dimensions of individual components, profiles, and finishes.
- B. Shop Drawings: Show fabrication and installation layouts of metal panels and tiles; details of edge conditions, joints, panel and tile profiles, corners, anchorages, attachment systems, trim, flashings, closures, and accessories; and special details. Distinguish between factory- and field-assembled work.
 1. Include structural data indicating compliance with performance requirements, including analysis data signed and sealed by the qualified professional engineer responsible for their preparation.
 2. Indicate coordination dimensions related to structural support system elements provided by others.
 3. Show details for forming, joining, and securing sheet metal siding, and for pattern of seams.

4. Show expansion-joint details and waterproof connections to adjoining work and at obstructions and penetrations.

- C. Samples for Verification: 12-inch- (300-mm-) square specimens of each type of sheet metal siding material with specified finishes applied. Where finishes involve normal color and texture variations, include Sample sets of 2 or more units showing the full range of variations expected.

1.4 INFORMATIONAL SUBMITTALS

- A. Product Certificates: Signed by sheet metal siding manufacturers certifying that the products furnished comply with requirements.
- B. Qualification Data: For firms and persons specified in the "Quality Assurance" Article to demonstrate their capabilities and experience. Include lists of completed projects with project names and addresses, names and addresses of architects and owners, and other information specified.
- C. Warranty: Sample of special warranty

1.5 QUALITY ASSURANCE

- A. Fabricator/Installer Qualifications: Engage an experienced sheet metal fabricator/installer with 10 years experience, who has completed sheet metal siding similar in material, design, forming method, and extent to that indicated for this Project and with a record of successful in-service performance.
 1. The fabricator and installer of the wall panel system shall be trained by the zinc material manufacturer. Installer shall submit list of three (3) successful "natural metal" project installations of similar complexity and scope.
- B. Professional Engineer Qualifications: A professional engineer who is legally qualified to practice in the jurisdiction where Project is located and who is experienced in providing engineering services of the kind indicated. Engineering services are defined as those performed for installations of metal wall panel systems including secondary framing that are similar to those indicated for this Project in material, design, and extent.
- C. Sheet Metal Standard: Comply with SMACNA's "Architectural Sheet Metal Manual." Conform to dimensions and profiles shown unless more stringent requirements are indicated.
- D. Single Source Responsibility: Provide panels and tiles which are the product of one manufacturer. Provide secondary materials, which are acceptable to the metal siding manufacturer.
- E. Field Measurements: Verify locations of framing dimensions by field measurements before metal panel fabrication and indicate measurements on Shop Drawings.

- F. Mockups: Before installing sheet metal siding, construct mockups for each form of construction and finish required to verify selections made under Sample submittals and to demonstrate aesthetic effects and qualities of materials and execution. Build mockups to comply with the following requirements, using exposed and concealed materials and forming methods indicated for completed Work.
1. Locate mockups on-site in the locations and of the sizes as directed by Architect.
 2. Notify Architect 7 days in advance of the dates and times when mockups will be constructed.
 3. Demonstrate the proposed range of aesthetic effects and workmanship.
 4. Reprepare mock-ups as required to obtain Architect's approval.
 5. Obtain Architect's approval of mockups before starting sheet metal siding Work.
 6. Maintain mockups during construction in an undisturbed condition as a standard for judging the completed Work.
 7. When directed, remove mockups from Project site.
- G. Pre-Installation Conference: Prior to commencement of work, convene an installation conference to include the Architect, General Contractor and Zinc Panel Installer in order to establish procedures to maintain optimum working conditions and to coordinate this work with related and adjacent work.
1. Review methods and procedures for installation including, but not limited to: substrates, sub framing, penetrations and other preparatory work.
 2. Review drawings, specifications, submittals and other contract documents
 3. Review construction schedule verifying availability of all materials, personnel and equipment needed to proceed and avoid delays
 4. Review weather and forecasted weather conditions and procedures for coping with unfavorable conditions, including cold temperatures.

1.6 DELIVERY, STORAGE, AND HANDLING

- A. Deliver sheet metal coils, panels, and other siding materials so they will not be damaged or deformed. Package siding materials for protection against transportation damage.
- B. Handling: Exercise care in unloading, storing, and erecting siding materials to prevent bending, warping, twisting, and surface damage.
1. Require all personnel to wear clean white cotton gloves when handling and installing zinc panels and accessories when no strippable film is present.
- C. Stack materials on platforms or pallets, covered with tarpaulins or other suitable weathertight and ventilated covering. Store sheet metal coils and panels to ensure dryness. Do not store coils or panels in contact with other materials that might cause staining, denting, or other surface damage.

1.7 PROJECT CONDITIONS

- A. Coordinate Work of this Section with interfacing and adjoining Work for proper sequencing of each installation. Ensure best possible weather resistance, durability of Work, and protection of materials and finishes.
- B. Corrosion Control: Avoid direct contact of incompatible materials including but not limited to copper, red rosin paper and masonry cleaning solutions.
 - 1. Do not start installation of zinc siding until masonry has received its final washdown.
- C. Weather Limitations: Proceed with installation only when existing and forecasted weather conditions permit assembly of metal panels to be performed according to manufacturers' written instructions and warranty requirements.

1.8 WARRANTY

- A. General Warranty: Special warranties specified in this Article shall not deprive the Owner of other rights the Owner may have under other provisions of the Contract Documents and shall be in addition to, and run concurrent with, other warranties made by the Contractor under requirements of the Contract Documents.
- B. Material Only Warranty: provide 20-year limited warranty for Titanium-Zinc alloy from original rolling mill manufacturer. Warranty to cover the material quality of the sheet/ coil material used to fabricate sheet metal flashing & trim profiles appropriate for zinc installation.
- C. Fabrication Warranty: provide 5-year fabrication warranty against sharp bends that fracture the metal, tears, and equipment induced damage to the Architectural Zinc sheet or coil.
- D. Installation Warranty: provide 2-year guarantee covering the proper material or product application preventing failure due to hot-water corrosion, damage due to inappropriate slip sheet, absorptive separation material, or other installer induced failure.

PART 2 - PRODUCTS

2.1 MANUFACTURERS

- A. Sheet Metal Manufacturers: Provide Basis of Design Products by RHEINZINK America Inc., or equal products by VM Zinc.

2.2 METALS

- A. Zinc Alloy Sheet/Coils: Titanium Zinc Alloy whose base is electrolytic high grade with a 99.995 % Zn degree of purity and alloying additives of 0.08% - 1.0% copper and 0.07% - .12% titanium, .001% - .015% aluminum in accordance with ASTM B69-20 (or latest edition) - Architectural Rolled Zinc - Type 1

1. Basis of Design Product: RHEINZINK-GRANUM phosphating process, "Sky-Grey" color and finish; or equal.
2. Minimum Panel Thickness: 0.8 mm (22 ga.) for flat lock tiles and trim, and 1.0 mm (20 ga.) for reveal panels and trim.

2.3 MISCELLANEOUS METAL FRAMING

- A. Steel Sheet Components, General: Complying with ASTM C 645 requirements for metal and with ASTM A 653/A 653M, G60 (Z180), hot-dip galvanized zinc coating.
- B. Subgirts: C- or Z-shaped sections fabricated from 0.0598-inch (1.5-mm) bare steel thickness, shop-painted, cold-formed, metallic-coated steel sheet.
- C. Base or Sill Angles and Channels: 0.079-inch (2.0-mm) bare steel thickness, cold-formed, galvanized steel sheet.
- D. Hat-Shaped, Rigid Furring Channels: ASTM C 645.
 1. Minimum Base Metal Thickness: 0.0179 inch (0.45 mm)
 2. Depth: 7/8 inch (22 mm) unless otherwise indicated.
- E. Cold-Rolled Furring Channels: 0.0538-inch (1.37-mm) bare steel thickness, with minimum 1/2-inch- (13-mm-) wide flange.
 1. Depth: As indicated.
- F. Furring Brackets: Adjustable, corrugated-edge type of steel sheet with minimum bare steel thickness of 0.0312 inch (0.79 mm).
- G. Tie Wire: ASTM A 641/A 641M, Class 1 zinc coating, soft temper, 0.0625-inch- (1.59-mm-) diameter wire, or double strand of 0.0475-inch- (1.21-mm-) diameter wire.
- H. Fasteners for Metal Framing: Of type, material, size, corrosion resistance, holding power, and other properties required to fasten steel members to substrates.

2.4 ACCESSORIES

- A. General: Provide components matching sheet metal siding in finish and material that are required for a complete siding system. Comply with Division 07 Section "Sheet Metal Flashing and Trim" for requirements.
- B. Provide all components necessary for a complete, functional, weatherproof assembly including, but not limited to, trims, copings, fascias, sills, flashings, counter flashings, door frame trim, corner units, soldering, clips, wall caps, copings, sealants, closures, fillers, foam tapes, and gaskets. All accessories shall be zinc compatible.
- C. Clips and Fasteners: Provide stainless steel concealed clips and stainless steel fasteners; of types and sizes as required in accordance with manufacturer's recommendations and per the engineering calculations. Attachment clips shall permit expansion and contraction

of the panel system throughout the specified temperature range. Provide fasteners with watertight washer gaskets (such as self-adhered membrane) for permeable air barrier sheets.

- D. Solder: Lead solder containing 50% tin and 50% lead in accordance with ASTM B32 - 08 (or latest edition) or lead-free solder.
- E. Flux: Felder ZD-Pro or equal.
- F. Air Barrier Underlayment: Provide vapor permeable sheet underlayment; Tyvek Commercial Wrap or equal (note taped joints and fastener gasket requirement).
- G. Sealants:
 - 1. Seam Sealing Tape: pressure-sensitive 100 per cent solid polyisobutylene compound sealing tape with release paper backing. Provide permanently elastic, non-sag, non-toxic non-staining tape.
 - 2. Joint Sealant: DOW 795 or other documented pH neutral sealant.
 - 3. Backer rod shall be extruded polyethylene foam as DOW ETHAFOAM SB or equal.
 - 4. Foam tapes at stiffeners shall be compressible open cell breathable type.

2.5 FABRICATION

- A. General: Custom fabricate sheet metal panels to comply with details shown and recommendations in SMACNA's "Architectural Sheet Metal Manual" and RHEINZINK Division 7 Binder; Latest Edition that apply to the design, dimensions (pan width and depth), geometry, metal thickness, and other characteristics of installation indicated. Shop fabricates sheet metal wall panels and accessories at the shop to the greatest extent possible.
- B. Flat-Lock Tile Wall Panels: Form flat-lock tile panels from continuous metal sheets, with two hooks (hems) turned under and two hooks (hems) turned over. A minimum of a ¾" hook (hem) is required; relief cuts are recommended for ease of installation (contact RHEINZINK for proper notching pattern).
- C. Fabricate sheet metal wall panels to allow for expansion in running work sufficient to prevent leakage, damage, and deterioration of the Work. Form exposed sheet metal work to fit substrates without excessive oil canning, buckling, and tool marks, true to line and levels indicated, and with exposed edges folded back to form hems.
- D. Form and fabricate sheets, seams, strips, cleats, edge treatments, integral flashing, and other components of metal wall to profiles, patterns, and drainage arrangements shown and as required to resist Water infiltration without excessive use of sealants (dry joints) while also allowing any water infiltration behind the wall panels to weep out.
- E. Sealant Joints: Where movable, non-expansion type joints are indicated or required to produce weather tight seams such as at window and door penetrations, form metal to provide for proper installation of elastomeric sealant in compliance with SMACNA standards.

PART 3 - EXECUTION

3.1 EXAMINATION

- A. Examine substrates and conditions, with Installer present, for compliance with requirements indicated for conditions affecting performance of sheet metal siding. Do not proceed with installation until unsatisfactory conditions have been corrected.
- B. Examine primary and secondary framing to verify that structural panel support members and anchorages have been installed within alignment tolerances required by manufacturer.
 - 1. Examine roughing-in for components and systems penetrating metal panels to verify actual locations of penetrations relative to seam locations of metal panels before metal panel installation.

3.2 PREPARATION

- A. Coordinate sheet metal siding with flashing, trim, and construction of walls and other adjoining work to provide a leakproof, secure, and noncorrosive installation.
- B. Promptly remove protective film, if any, from exposed surfaces of sheet metal siding. Strip with care to avoid damage to finish.
- C. Miscellaneous Framing: Install subpurlins, eave angles, furring, and other miscellaneous panel support members and anchorage according to metal panel manufacturer's written recommendations and approved shop drawings.
- D. Install air barrier underlayment on substrate in accordance with air barrier manufacturer's installation instructions. Comply with manufacturer's requirements for underlayment end and side laps, attachment, seaming, and terminations.

3.3 INSTALLATION, GENERAL

- A. General: Unless otherwise indicated, install sheet metal siding, flashing and trim to comply with performance requirements, manufacturer's installation instructions, and SMACNA's "Architectural Sheet Metal Manual". Anchor Work securely in place by methods indicated, providing for thermal expansion of sheet metal units; conceal fasteners and set units true to line and level as indicated. Install Work with laps, joints, and seams that will be permanently watertight and weatherproof.
- B. Separate dissimilar metals by painting each metal surface in area of contact with a bituminous coating, by applying rubberized-asphalt underlayment to each metal surface, or by other permanent separation as recommended by manufacturers of dissimilar metals.
- C. Expansion Provisions in Accessories: Space movement joints at maximum of 10 feet (3 m) with no joints allowed within 24 inches (610 mm) of corner or intersection. Where

lapped or bayonet-type expansion provisions in Work cannot be used or would not be sufficiently weatherproof and waterproof, form expansion joints of intermeshing hooked flanges, not less than 1 inch (25 mm) deep, filled with mastic sealant (concealed within joints).

- D. Sealant-Type Joints: Where sealant-filled joints are used, embed hooked flanges of joint members not less than 1 inch (25 mm) into sealant. Form joints to completely conceal sealant. When ambient temperature is moderate, between 40 and 70 deg F (4 and 21 deg C), at time of installation, set joint members for 50 percent movement either way. Adjust setting proportionately for installation at higher ambient temperatures. Do not install sealant-type joints at temperatures below 40 deg F (4 deg C). Comply with requirements of Division 07 Section "Joint Sealants" for handling and installing sealants.
- E. Fabricate and install work with lines and corners of exposed units true and accurate. Form exposed faces flat and free of buckles, oil-canning, excessive waves, and avoidable tool marks, considering temper and reflectivity of sheet metal. Provide uniform, neat seams with minimum exposure of solder, welds, and sealant. Fold back sheet metal to form a hem on concealed side of exposed edges, unless otherwise indicated.
 - 1. All shop and field fabricated bends shall have an acceptable "rounded" or radius bend. NO SHARP BREAKS.
- F. Conceal fasteners and expansion provisions where possible in exposed work and locate to minimize possibility of leakage. Cover and seal fasteners and anchors as required for a tight installation.
- G. Roof-Edge Flashings and Edge Securement: Secure metal flashings, copings and edge securement at roof edges according to Building Code of NY, Chapter 16 for specified wind zone.

3.4 SHEET METAL SIDING INSTALLATION

- A. Verify shapes and dimensions of surfaces to be covered before fabricating sheet metal.
- B. Install work to meet specified performance requirements. Flat-Lock Tile panels shall be installed from the bottom up. CAUTION: Horizontal and Vertical Flat-Lock Tile panel applications become directional when notched according to RHEINZINK'S recommendations .
- C. Soldered Joints: Clean surfaces to be soldered, removing oils and foreign matter. Pretin edges of sheets to be soldered to a width of 1-1/2 inches (38 mm), except where pretinned surface would show in finished Work.
 - 1. Do not use torches for soldering. Heat surfaces to receive solder and flow solder into joint. Fill joint completely. Completely remove flux and spatter from exposed surfaces.

- D. Sealed Joints: Form nonexpansion, but movable, joints in sheet metal to accommodate elastomeric sealant to comply with siding manufacturer's standards. Fill joint with sealant and form sheet metal to completely conceal sealant.
 - 1. Use joint adhesive for nonmoving joints specified not to be soldered.
- E. Seams: Fabricate nonmoving seams in sheet metal with flat-lock seams. Tin edges to be seamed, form seams, and solder, or seal seams with specified elastomeric joint sealant, as approved by the Architect.
- F. Counterflashings: Coordinate installation of counterflashings with installation of assemblies to be protected by counterflashing. Install counterflashings in reglets or receivers. Secure in a waterproof manner by means of snap-in installation and sealant, lead wedges and sealant, interlocking folded seam, or blind rivets and sealant. Lap counterflashing joints a minimum of 2 inches (50 mm) and bed with sealant.
- G. Fascia and Copings: Install cleats, anchor plates, and other anchoring and attachment accessories and devices with concealed fasteners. Anchor fasciae and copings to meet performance requirements.
- H. Installation Tolerances: Shim and align metal wall panels within installed tolerance of 1/4 inch in 20 feet (6 mm in 6 m), nonaccumulative, on level, plumb, and location lines as indicated and within 1/8-inch (3-mm) offset of adjoining faces and of alignment of matching profiles.

3.5 CLEANING

- A. Clean exposed sheet metal surfaces of substances that interfere with uniform oxidation and weathering.

3.6 PROTECTION

- A. Provide final protection and maintain conditions, in a manner acceptable to manufacturer and Installer, that ensure sheet metal siding is without damage or deterioration at the time of Substantial Completion.

END OF SECTION 076223

SECTION 077200 - ROOF ACCESSORIES

PART 1 - GENERAL

1.1 SUMMARY

A. This Section includes the following:

1. Roof hatches
2. Hatch safety railing system
3. Ladder safety post.

B. Related Work Specified Elsewhere:

1. Roof ladders are specified in Division 05 Section "Metal Fabrications."
2. Vegetated roof trays are specified in Division 07 Section "Vegetated Roof Systems."

1.2 SUBMITTALS

A. Product Data: For each type of product indicated. Include construction details, materials, dimensions of individual components and profiles, and finishes.

B. Shop Drawings: Show fabrication and installation details. Indicate dimensions, weights, loadings, required clearances, method of field assembly, and components. Include plans, elevations, sections, details, and attachments to other Work.

C. Coordination Drawings: Roof plans drawn to scale and coordinating penetrations and roof-mounted items. Show the following:

1. Size and location of roof accessories specified in this Section.
2. Method of attaching roof accessories to roof or building structure.
3. Other roof-mounted items including mechanical and electrical equipment, ductwork, piping, and conduit.

1.3 QUALITY ASSURANCE

A. Standards: Comply with the following:

1. SMACNA's "Architectural Sheet Metal Manual" details for fabrication of units, including flanges and cap flashing to coordinate with type of roofing indicated.
2. NRCA's "Roofing and Waterproofing Manual" details for installing units.

PART 2 - PRODUCTS

2.1 MANUFACTURERS

- A. Available Manufacturers: Subject to compliance with requirements, manufacturers offering products that may be incorporated into the Work include, but are not limited to, the following:
 - 1. Hatches and Safety Railings:
 - a. Babcock-Davis Hatchways, Inc.
 - b. Bilco Company.
 - c. Greenheck
 - d. Milcor, Inc.

2.2 MATERIALS, GENERAL

- A. Galvanized Steel Sheet: ASTM A 653/A 653M with G90 (Z275) coating designation; commercial quality, unless otherwise indicated.
 - 1. Structural Quality: Grade 40 (Grade 275), where indicated or as required for strength.
- B. Aluminum Sheet: ASTM B 209 (ASTM B 209M) for alclad alloy 3005H25 or alloy and temper required to suit forming operations, with mill finish, unless otherwise indicated.
- C. Extruded Aluminum: ASTM B 221 (ASTM B 221M) alloy 6063-T52 or alloy and temper required to suit structural and finish requirements, with mill finish, unless otherwise indicated.
- D. Insulation: Manufacturer's standard rigid or semirigid glass-fiber board of thickness indicated.
- E. Fasteners: Same metal as metals being fastened, or nonmagnetic stainless steel or other noncorrosive metal as recommended by manufacturer. Match finish of exposed fasteners with finish of material being fastened.
- F. Gaskets: Manufacturer's standard tubular or fingered design of neoprene, EPDM, or PVC; or flat design of foam rubber, sponge neoprene, or cork.
- G. Bituminous Coating: SSPC-Paint 12, solvent-type bituminous mastic, nominally free of sulfur and containing no asbestos fibers, compounded for 15-mil (0.4-mm) dry film thickness per coating.
- H. Mastic Sealant: Polyisobutylene; nonhardening, nonskinning, nondrying, nonmigrating sealant.
- I. Elastomeric Sealant: Generic type recommended by unit manufacturer that is compatible with joint surfaces; ASTM C 920, Type S, Grade NS, Class 25, and Uses NT, G, A, and, as applicable to joint substrates indicated, O.

- J. Roofing Cement: ASTM D 4586, nonasbestos, fibrated asphalt cement designed for trowel application or other adhesive compatible with roofing system.

2.3 ROOF HATCHES

- A. General: Fabricate units to withstand 40-lbf/sq. ft. external loading pressure and a 20 psf wind uplift pressure. Cover and curb shall be thermally broken. Frame with minimum 12-inch-high, integral-curb with 3-inch insulation, mounting flange and cap flashing (roofing counterflashing), with welded or sealed mechanical corner joints. Provide double-wall cover (lid) construction with 3- inch-thick insulation core. Provide EPDM compression gasketing and equip with corrosion-resistant or hot-dip galvanized hardware including pintle hinges, hold-open devices, interior and exterior padlock hasps, and both interior and exterior latch handles.
- B. Type: Single-leaf equipment access.
- C. Size: 30" x 54".
- D. Material: Aluminum covers (lids) and curbs, fabricated from 11 gauge aluminum with a 18 gauge aluminum cover liner.
- E. Finish: Mill finish.
- F. Basis of Design Product: Type NB-50TB manufactured by Bilco or equal.

2.4 HATCH RAIL SYSTEM

- A. Performance Characteristics: Hatch rail system shall satisfy the requirements of OSHA 29 CFR 1910.29 and shall meet OSHA strength requirements with a factor of safety of two.
- B. Posts and Rails: 1-1/4" round 6061-T6 schedule 40 aluminum pipe with factory applied safety yellow powder coat paint finish. Provide self-closing gate and positive latching system.
- C. Hardware: Mounting brackets shall be 3/8" thick extruded aluminum. Post guides shall be cast aluminum. Hinges and fasteners shall be Type 316 stainless steel.
- D. Manufacturer: Bilco Bil-Guard 2.0 Roof Hatch Railing System, Model RL2-NBTB or equal

2.5 ROOF HATCH ACCESSORIES

- A. Ladder Safety Post: Preassembled unit with tubular post locking automatically when fully extended, and controlled upward and downward movement, release lever to disengage the post to allow it to be returned to its lowered position, and adjustable mounting brackets to fit ladder rungs.
 - 1. Material: Steel

2. Balancing Spring and Hardware Material: Stainless steel
3. Steel Finish: Safety yellow powder coat.
4. Basis of Design Product: Bilco Ladder-Up Safety Post, Model LU-1 or equal.

2.6 FINISHES, GENERAL

- A. Comply with NAAMM's "Metal Finishes Manual for Architectural and Metal Products" for recommendations for applying and designating finishes.
- B. Protect mechanical finishes on exposed surfaces from damage by applying a strippable, temporary protective covering before shipping.

2.7 ALUMINUM FINISHES

- A. Finish designations prefixed by AA comply with the system established by the Aluminum Association for designating aluminum finishes.
- B. Mill Finish: AA-M10 (Mechanical Finish: as fabricated, unspecified).
- C. Powder Paint Finish: Manufacturer's standard.

2.8 GALVANIZED STEEL SHEET FINISHES

- A. Surface Preparation: Clean surfaces with nonpetroleum solvent so surfaces are free of oil and other contaminants. After cleaning, apply a conversion coating suited to the organic coating to be applied over it. Clean welds, mechanical connections, and abraded areas, and apply galvanizing repair paint specified below to comply with ASTM A 780.
 1. Galvanizing Repair Paint: High-zinc-dust-content paint for regalvanizing welds in steel, complying with SSPC-Paint 20.
- B. Factory Priming for Field-Painted Finish: Where field painting after installation is indicated, apply the air-dried primer specified below immediately after cleaning and pretreating.
 1. Shop Primer: Manufacturer's standard, compatible with finish paint specified in Division 09 Section "Painting."
- C. Factory Finished Powder Paint System: Manufacturer's standard.

PART 3 - EXECUTION

3.1 INSTALLATION

- A. General: Comply with manufacturer's written instructions. Coordinate installation of roof accessories with installation of roof deck, roof insulation, flashing, roofing membranes, penetrations, equipment, and other construction involving roof accessories to ensure that

each element of the Work performs properly and that combined elements are waterproof and weathertight. Anchor roof accessories securely to supporting structural substrates so they are capable of withstanding lateral and thermal stresses, and inward and outward loading pressures.

- B. Install roof accessory items according to construction details of NRCA's "Roofing and Waterproofing Manual," unless otherwise indicated.
- C. Separation: Separate metal from incompatible metal or corrosive substrates, including wood, by coating concealed surfaces, at locations of contact, with bituminous coating or providing other permanent separation.
- D. Flange Seals: Unless otherwise indicated, set flanges of accessory units in a thick bed of roofing cement to form a seal.
- E. Cap Flashing: Where required as component of accessory, install cap flashing to provide waterproof overlap with roofing or roof flashing (as counterflashing). Seal overlap with thick bead of mastic sealant.
- F. Operational Units: Test-operate units with operable components. Clean and lubricate joints and hardware. Adjust for proper operation.

3.2 CLEANING AND PROTECTION

- A. Clean exposed surfaces according to manufacturer's written instructions. Touch up damaged metal coatings.

END OF SECTION 077200

SECTION 077273 - VEGETATED ROOF SYSTEMS

PART 1 - GENERAL

1.1 SUMMARY

- A. This Section includes the following:
 - 1. Modular system of preplanted plastic modules containing a drainage layer with growth media and plant species preplaced into the module.
 - 2. Slip sheet for separation from roof membrane surface.
- B. Roofing membrane is specified in Section 075323.

1.2 SUBMITTALS

- A. Product Data: Before materials are delivered to site, submit manufacturer's printed product data and specifications for all materials and components of green roof system. Include installation instructions and data substantiating that materials comply with requirements.
- B. Shop Drawings: Show roof configuration and module layout, location and type of all penetrations, termination details, and all other application details, each at an appropriate scale.
- C. Qualification Data: For firms and persons specified in the "Quality Assurance" Article to demonstrate their capabilities and experience. Include lists of completed projects with project names and addresses, names and addresses of architects and owners, and other information specified.
- D. Maintenance Data: For green roof system to include in the maintenance manuals specified in Division 01 Section "Closeout Procedures."
- E. Warranty: Sample copy of green roof system manufacturer's warranty stating obligations, remedies, limitations, and exclusions of warranty as stated in "Warranty" Article.
- F. Inspection Report: Copy of green roof system manufacturer's inspection report of completed installation, specified in the "Quality Assurance" Article.

1.3 QUALITY ASSURANCE

- A. Manufacturer: Obtain primary green roof system materials from a single manufacturer. Provide secondary materials as produced by or accepted by manufacturer of primary materials.

- B. Installer: Green roof system and all associated work shall be installed by a firm that has five (5) years experience in the installation of green roofing systems similar to the system specified.
- C. Single-Source Responsibility: The vegetated roof assembly shall be installed in conjunction with the membrane roof system installer as a single source installer or a partnership for single source responsibility of membrane roof system warranty and vegetated roof assembly warranty covering replacement of overburden in the event roofing repair service is required.
- D. Pre-Roofing Inspection and Certification: Prior to start of installation of the work of this Section, secure a visit to the job site by a representative of the manufacturer of the roofing membrane used who shall inspect the job conditions and shall certify in writing to the Architect that each of the surfaces to which the green roof system materials will be applied is in a condition suitable for this application.
- E. Preinstallation Conference: Before installing green roof system, conduct conference at Project site to comply with requirements of Division 01 Section "Project Management and Coordination."
- F. Post-Roofing Inspection: At the completion of the installation of the green roof system, a representative of the green roof system manufacturer shall inspect the work as required to provide the manufacturer's guarantee as specified below. The representative shall either approve the work or shall order changes in the work required for approval in which case he shall reinspect the work after the changes have been made.
 - 1. Notify Architect or Owner 48 hours in advance of the date and time of inspection.

1.4 DELIVERY, STORAGE, AND HANDLING

- A. Deliver materials to Project site in original containers with seals unbroken and labeled with manufacturer's name, product brand name and type, and directions for storing.
- B. Install planted modules on rooftop within 4 hours of delivery.

1.5 PROJECT CONDITIONS

- A. Weather: Proceed with green roof system work when existing and forecasted weather conditions permit work to be performed in accordance with manufacturers' recommendations and warranty requirements.
- B. Installation Season: Install during the time period of April 1 to October 15, unless otherwise recommended by manufacturer.
- C. Coordination with Roofing Membrane Warranty: Roofing membrane manufacturer shall provide "single source" warranty that includes the vegetated cover and the membrane roofing system. covering removal and replacement of vegetated roofing system in the event repair work is required on the roof membrane.

1.6 SPECIAL PROJECT WARRANTY

- A. The warranty specified in the Article shall not deprive the Owner of other rights the Owner may have under other provisions of the Contract Documents and shall be in addition to and run concurrent with other warranties made by the Contractor under requirements of the Contract Documents.
- B. Upon completion of this portion of the Work, and as a condition of its acceptance, deliver to the Owner the following written guarantees:
 - 1. The installer will guarantee a uniform stand of plants by watering and maintaining green roof areas until final acceptance, and will replant areas that fail to provide a uniform stand of plants until all areas are accepted by Owner.

1.7 MAINTENANCE SERVICE

- A. Initial Maintenance Service: Provide full maintenance by skilled employees of installer. Maintain as required in Part 3. Begin maintenance immediately after each area is planted and continue until acceptable green roof system is established, but for not less than 30 days from date of Substantial Completion.

PART 2 - PRODUCT

2.1 GENERAL

- A. Basis of Design Product: Provide "GreenGrid G4 Module" Extensive Module manufactured by Weston Solutions or equal.

2.2 MATERIALS

- A. Modules: Formed from black or grey 100mil thick HDPE (100% recycled post industrial material) 24" x 24" in size, with 4-1/4" depth of modules. Modules shall have water retention reservoirs, bottom drainage holes and integrated handles.
- B. Underlayment Material: Heavy duty HDPE, Polypropylene, TPO, EPDM or recyclable PVC slip sheet/root barrier of 40-60 mil. thickness with effectively bonded seams. Material shall be compatible with roofing membrane system.
- C. Growth media shall be engineered light weight blend inorganic content, provided by module manufacturer, and appropriate for materials being planted. Saturated weight with mature vegetation shall be 26-30 lbs. per square foot.
- D. Ground Covers and Plants: Design mix of grasses, perennials and groundcovers that can thrive in non-irrigated extensive rooftop environment in project location; exact mix as approved by Architect. Plants shall be grown to maturity (approximately 95+% soil coverage) before delivery to site.

PART 3 - EXECUTION

3.1 INSPECTION

- A. Prior to work of this Section, carefully inspect all surfaces and verify that surfaces are satisfactory so that the work of this Section may properly commence. Verify that green roof system may be installed in strict accordance with the manufacturer's current recommendations, and all pertinent codes and regulations.
- B. Examine substrates, areas, and conditions under which system will be applied, with roofing Installer present, for compliance with requirements.
- C. Do not proceed with installation until unsatisfactory conditions have been corrected. In the event of discrepancy, immediately notify the Architect. Do not proceed with installation in areas of discrepancy until all such discrepancies have been fully resolved.

3.2 SURFACE PREPARATION

- A. Clean substrate of dust, debris, and other substances detrimental to green roof system installation according to manufacturer's written instructions .
- B. Prevent materials from entering and clogging roof drains and conductors and from spilling or migrating onto surfaces of other construction. Remove roof-drain plugs when no work is taking place or when rain is forecast.

3.3 INSTALLATION

- A. Place underlayment sheet over completed and tested membrane roof. Place modules on roof surface in arrangement according to approved landscape design and shop drawings. Water modules to insure growth.

3.4 MAINTENANCE

- A. Maintain and establish green roof system by watering, fertilizing, weeding, trimming, replanting, and other operations. Replant bare or eroded areas and those damaged by insects or disease. Provide materials and installation the same as those used in the original installation.
- B. Watering: Provide and maintain temporary piping, hoses, and lawn-watering equipment to convey water from sources and to keep green roof system uniformly moist to a depth of 4 inches (100 mm).
 - 1. Water with fine spray at a minimum rate of 1 inch (25 mm) per week unless rainfall precipitation is adequate.

- C. Acceptance: Upon completion of maintenance period, Owner will inspect green roof system to determine if a uniform stand of plants exists, and will accept if all requirements have been met. Upon acceptance, Owner will assume maintenance of green roof system.

END OF SECTION 077273

SECTION 078100 - APPLIED FIREPROOFING

PART 1 - GENERAL

1.1 SUMMARY

- A. Section includes sprayed fire-resistive materials (SFRM).
- B. Locations of sprayed fire-resistive materials includes the following:
 - 1. Steel columns, wide-flange and hollow structural section types, where indicated
 - 2. Roof construction including deck, beams and joists where indicated.
 - 3. Floor construction including deck, beams and joists where indicated
 - 4. Any other area indicated on the Drawings.

1.2 PREINSTALLATION MEETINGS

- A. Preinstallation Conference: Conduct conference at Project site
 - 1. Review products, design ratings, restrained and unrestrained conditions, densities, thicknesses, bond strengths, and other performance requirements.

1.3 ACTION SUBMITTALS

- A. Product Data: For each type of product.
- B. UL Designs: For each UL Design proposed for use.
- D. Shop Drawings: Framing plans, schedules, or both, indicating the following:
 - 1. Extent of fireproofing for each construction and fire-resistance rating.
 - 2. Applicable fire-resistance design designations of a qualified testing and inspecting agency acceptable to authorities having jurisdiction.
 - 3. Minimum fireproofing thicknesses needed to achieve required fire-resistance rating of each structural component and assembly.
 - 4. Treatment of fireproofing after application.

1.4 INFORMATIONAL SUBMITTALS

- A. Qualification Data: For Installer and testing agency.
- B. Product Certificates: For each type of fireproofing.
- C. Evaluation Reports: For fireproofing, from ICC-ES.
- D. Preconstruction Test Reports: For fireproofing.
- E. Field quality-control reports.

1.5 QUALITY ASSURANCE

- A. Installer Qualifications: A firm or individual certified, licensed, or otherwise qualified by fireproofing manufacturer as experienced and with sufficient trained staff to install manufacturer's products according to specified requirements.
- B. Mockups: Build mockups to verify selections made under Sample submittals and to set quality standards for materials and execution and for preconstruction testing.
 - 1. Build mockup of each type of fireproofing and different substrate as shown on Drawings.
 - 2. Approval of mockups does not constitute approval of deviations from the Contract Documents contained in mockups unless Architect specifically approves such deviations in writing.
 - 3. Subject to compliance with requirements, approved mockups may become part of the completed Work if undisturbed at time of Substantial Completion.
- C. Coordination: Coordinate installation of spray fireproofing with installation of ceiling-mounted supports and hangars for mechanical and electrical equipment installed by others.

1.6 PRECONSTRUCTION TESTING

- A. Preconstruction Testing Service: Owner will engage a qualified testing agency to perform preconstruction testing on field mockups of fireproofing.
 - 1. Provide test specimens and assemblies representative of proposed materials and construction.
- B. Preconstruction Adhesion and Compatibility Testing: Test for compliance with requirements for specified performance and test methods.
 - 1. Bond Strength: Test for cohesive and adhesive strength according to ASTM E 736. Provide bond strength indicated in referenced fire-resistance design, but not less than minimum specified in Part 2.
 - 2. Density: Test for density according to ASTM E 605. Provide density indicated in referenced fire-resistance design, but not less than minimum specified in Part 2.
 - 3. Verify that manufacturer, through its own laboratory testing or field experience, attests that primers or coatings are compatible with fireproofing.
 - 4. Schedule sufficient time for testing and analyzing results to prevent delaying the Work.
 - 5. For materials failing tests, obtain applied-fireproofing manufacturer's written instructions for corrective measures including the use of specially formulated bonding agents or primers.

1.7 FIELD CONDITIONS

- A. Environmental Limitations: Do not apply fireproofing when ambient or substrate temperature is 44 deg F (7 deg C) or lower unless temporary protection and heat are

provided to maintain temperature at or above this level for 24 hours before, during, and for 24 hours after product application.

- B. Ventilation: Ventilate building spaces during and after application of fireproofing, providing complete air exchanges according to manufacturer's written instructions. Use natural means or, if they are inadequate, forced-air circulation until fireproofing dries thoroughly.

PART 2 - PRODUCTS

2.1 MATERIALS, GENERAL

- A. Assemblies: Provide fireproofing, including auxiliary materials, according to requirements of each fire-resistance design and manufacturer's written instructions.
- B. Source Limitations: Obtain fireproofing from single source.
- C. Fire-Resistance Design: Indicated on Drawings, tested according to ASTM E 119 or UL 263 by a qualified testing agency. Identify products with appropriate markings of applicable testing agency.
 - 1. Steel members are to be considered unrestrained unless specifically noted otherwise.
- D. VOC Content: Products shall comply with VOC content limits of authorities having jurisdiction and the following VOC limits when calculated according to 40 CFR 59, Subpart D (EPA Method 24):
 - 1. Primers, Sealers, and Undercoaters: 200 g/L.
 - 2. Anticorrosive and Antirust Paints Applied to Ferrous Metals: 250 g/L.
- E. Asbestos: Provide products containing no detectable asbestos.

2.2 SPRAYED FIRE-RESISTIVE MATERIALS

- A. SFRM: Manufacturer's standard, factory-mixed, lightweight, dry formulation, complying with indicated fire-resistance design, and mixed with water at Project site to form a slurry or mortar before conveyance and application.
 - 1. Basis of Design Product: Provide Isolatek International; Cafco Blaze-Shield II or equal.
 - 2. Bond Strength: Minimum 150-lbf/sq. ft. (7.18-kPa) cohesive and adhesive strength based on field testing according to ASTM E 736.
 - 3. Density: Not less than 15 lb/cu. ft. (240 kg/cu. m) and as specified in the approved fire-resistance design, according to ASTM E 605.
 - 4. Thickness: As required for fire-resistance design indicated, measured according to requirements of fire-resistance design or ASTM E 605, whichever is thicker, but not less than 0.375 inch (9 mm).
 - 5. Combustion Characteristics: ASTM E 136.

6. Surface-Burning Characteristics: Comply with ASTM E 84; testing by a qualified testing agency. Identify products with appropriate markings of applicable testing agency.
 - a. Flame-Spread Index: 10 or less.
 - b. Smoke-Developed Index: 10 or less.
7. Compressive Strength: Minimum 1,440 lbf/sq. in. (68.9 kPa) according to ASTM E 761.
8. Corrosion Resistance: No evidence of corrosion according to ASTM E 937.
9. Deflection: No cracking, spalling, or delamination according to ASTM E 759.
10. Effect of Impact on Bonding: No cracking, spalling, or delamination according to ASTM E 760.
11. Air Erosion: Maximum weight loss of 0.025 g/sq. ft. (0.270 g/sq. m) in 24 hours according to ASTM E 859.
12. Fungal Resistance: Treat products with manufacturer's standard antimicrobial formulation to result in no growth on specimens per ASTM G21.
13. Sound Absorption: NRC of 0.75 according to ASTM C423 for Type A mounting according to ASTM E795.
14. Finish: Spray-textured finish.
15. UL Designs:
 - a. As required to achieve 1-hour fire-rating at columns.
 - b. As required to achieve 1-hour fire-rating at roof and floor beams, decking and joists.
16. Adjust thickness of sprayed on material for columns and beams (lintels) with W/D ratio less than the W/D ratio of the specified assembly, as described in UL Fire Resistance Directory, Design Information Section at the front of the directory.

2.3 AUXILIARY MATERIALS

- A. General: Provide auxiliary materials that are compatible with fireproofing and substrates and are approved by UL or another testing and inspecting agency acceptable to authorities having jurisdiction for use in fire-resistance designs indicated.
- B. Substrate Primers: Primers approved by fireproofing manufacturer and complying with one or both of the following requirements:
 1. Primer and substrate are identical to those tested in required fire-resistance design by UL or another testing and inspecting agency acceptable to authorities having jurisdiction.
 2. Primer's bond strength in required fire-resistance design complies with specified bond strength for fireproofing and with requirements in UL's "Fire Resistance Directory" or in the listings of another qualified testing agency acceptable to authorities having jurisdiction, based on a series of bond tests according to ASTM E 736.
- C. Bonding Agent: Product approved by fireproofing manufacturer and complying with requirements in UL's "Fire Resistance Directory" or in the listings of another qualified testing agency acceptable to authorities having jurisdiction.

- D. Metal Lath: Expanded metal lath fabricated from material of weight, configuration, and finish required, according to fire-resistance designs indicated and fireproofing manufacturer's written recommendations. Include clips, lathing accessories, corner beads, and other anchorage devices required to attach lath to substrates and to receive fireproofing.
- E. Reinforcing Fabric: Glass- or carbon-fiber fabric of type, weight, and form required to comply with fire-resistance designs indicated; approved and provided by fireproofing manufacturer.
- F. Reinforcing Mesh: Metallic mesh reinforcement of type, weight, and form required to comply with fire-resistance design indicated; approved and provided by fireproofing manufacturer. Include pins and attachment.
- G. Patching Material: Product approved by fireproofing manufacturer and complying with requirements in UL's "Fire Resistance Directory" or in the listings of another qualified testing agency acceptable to authorities having jurisdiction; Cafco Fiber Patch or equal.

2.4 EXAMINATION

- A. Examine substrates, areas, and conditions, with Installer present, for compliance with requirements for substrates and other conditions affecting performance of the Work and according to each fire-resistance design. Verify compliance with the following:
 - 1. Substrates are free of dirt, oil, grease, release agents, rolling compounds, mill scale, loose scale, incompatible primers, paints, and encapsulants, or other foreign substances capable of impairing bond of fireproofing with substrates under conditions of normal use or fire exposure.
 - 2. Objects penetrating fireproofing, including clips, hangers, support sleeves, and similar items, are securely attached to substrates.
 - 3. Substrates receiving fireproofing are not obstructed by ducts, piping, equipment, or other suspended construction that will interfere with fireproofing application.
- B. Verify that concrete work on steel deck has been completed before beginning fireproofing work.
- C. Verify that roof construction, installation of roof-top HVAC equipment, and other related work is complete before beginning fireproofing work.
- D. Conduct tests according to fireproofing manufacturer's written recommendations to verify that substrates are free of substances capable of interfering with bond.
- E. Prepare written report, endorsed by Installer, listing conditions detrimental to performance of the Work.
- F. Proceed with installation only after unsatisfactory conditions have been corrected.

2.5 PREPARATION

- A. Cover other work subject to damage from fallout or overspray of fireproofing materials during application.
- B. Clean substrates of substances that could impair bond of fireproofing.
- C. Prime substrates where included in fire-resistance design and where recommended in writing by fireproofing manufacturer unless compatible shop primer has been applied and is in satisfactory condition to receive fireproofing.
- D. For applications visible on completion of Project, repair substrates to remove surface imperfections that could affect uniformity of texture and thickness in finished surface of fireproofing. Remove minor projections and fill voids that would telegraph through fire-resistive products after application.
- E. For areas with spray material on beams only, and exposed steel deck, cover deck to limit overspray of materials. Remove protective covering upon completion

2.6 APPLICATION

- A. Construct fireproofing assemblies that are identical to fire-resistance design indicated and products as specified, tested, and substantiated by test reports; for thickness, primers, sealers, topcoats, finishing, and other materials and procedures affecting fireproofing work.
- B. Comply with fireproofing manufacturer's written instructions for mixing materials, application procedures, and types of equipment used to mix, convey, and apply fireproofing; as applicable to particular conditions of installation and as required to achieve fire-resistance ratings indicated.
- C. Coordinate application of fireproofing with other construction to minimize need to cut or remove fireproofing.
 - 1. Do not begin applying fireproofing until clips, hangers, supports, sleeves, and other items penetrating fireproofing are in place.
 - 2. Defer installing ducts, piping, and other items that would interfere with applying fireproofing until application of fireproofing is completed.
- D. Metal Decks:
 - 1. Do not apply fireproofing to underside of metal deck substrates until concrete topping, if any, has been completed.
 - 2. Do not apply fireproofing to underside of metal roof deck until roofing has been completed; prohibit roof traffic during application and drying of fireproofing.
- E. Install auxiliary materials as required, as detailed, and according to fire-resistance design and fireproofing manufacturer's written recommendations for conditions of exposure and intended use. For auxiliary materials, use attachment and anchorage devices of type recommended in writing by fireproofing manufacturer.

- F. Spray apply fireproofing to maximum extent possible. Following the spraying operation in each area, complete the coverage by trowel application or other placement method recommended in writing by fireproofing manufacturer.
- G. Extend fireproofing in full thickness over entire area of each substrate to be protected.
- H. Install body of fireproofing in a single course unless otherwise recommended in writing by fireproofing manufacturer.
- I. For applications over encapsulant materials, including lockdown (post-removal) encapsulants, apply fireproofing that differs in color from that of encapsulant over which it is applied.
- J. Where sealers are used, apply products that are tinted to differentiate them from fireproofing over which they are applied.
- K. Provide a uniform finish complying with description indicated for each type of fireproofing material and matching finish approved for required mockups.
- L. Cure fireproofing according to fireproofing manufacturer's written recommendations.
- M. Do not install enclosing or concealing construction until after fireproofing has been applied, inspected, and tested and corrections have been made to deficient applications.
- N. Finishes: Where indicated, apply fireproofing to produce the following finishes:
 - 1. Manufacturer's Standard Finishes: Finish according to manufacturer's written instructions for each finish selected.
- O. The substrate shall have a minimum ambient temperature before and after application as specified in the approved manufacturer's written instructions. The area for application shall be ventilated during and after application as required by the approved manufacturer's written instructions.

2.7 FIELD QUALITY CONTROL

- A. Special Inspections: Owner will engage a qualified special inspector to perform the following special inspections as required by the BCNYS, Subsection 1705.13, "Sprayed Fire-Resistant Materials."
- B. Perform the tests and inspections of completed Work in successive stages. Do not proceed with application of fireproofing for the next area until test results for previously completed applications of fireproofing show compliance with requirements. Tested values must equal or exceed values as specified and as indicated and required for approved fire-resistance design. See Section 014000 "Quality Requirements" for retesting and reinspecting requirements and Section 017300 "Execution" for requirements for correcting the Work.
- C. Fireproofing will be considered defective if it does not pass tests and inspections.

1. Remove and replace fireproofing that does not pass tests and inspections, and retest.
2. Apply additional fireproofing, per manufacturer's written instructions, where test results indicate insufficient thickness, and retest.

D. Prepare test and inspection reports.

2.8 CLEANING, PROTECTING, AND REPAIRING

- A. Cleaning: Immediately after completing spraying operations in each containable area of Project, remove material overspray and fallout from surfaces of other construction and clean exposed surfaces to remove evidence of soiling.
- B. Protect fireproofing, according to advice of manufacturer and Installer, from damage resulting from construction operations or other causes, so fireproofing will be without damage or deterioration at time of Substantial Completion.
- C. As installation of other construction proceeds, inspect fireproofing and repair damaged areas and fireproofing removed due to work of other trades.
- D. Repair fireproofing damaged by other work before concealing it with other construction.
- E. Repair fireproofing by reapplying it using same method as original installation or using manufacturer's recommended trowel-applied product.

END OF SECTION 078100

SECTION 078123 – INTUMESCENT FIREPROOFING

PART 1 - GENERAL

1.1 SUMMARY

- A. Section includes mastic and intumescent fire-resistive coatings (MIFRC).

1.2 PREINSTALLATION MEETINGS

- A. Preinstallation Conference: Conduct conference at Project site.
 - 1. Review products, design ratings, restrained and unrestrained conditions, thicknesses, and other performance requirements.

1.3 ACTION SUBMITTALS

- A. Product Data: For each type of product indicated.
 - 1. Material List: Provide an inclusive list of required intumescent coating materials. Indicate each material and cross-reference specific coating, finish system, and application. Identify each material by manufacturer's catalog number and general classification.
- B. UL Designs: For each UL Design proposed for use.
- C. Shop Drawings: Structural framing plans indicating the following:
 - 1. Extent of fireproofing for each construction and fire-resistance rating.
 - 2. Applicable fire-resistance design designations of a qualified testing and inspecting agency acceptable to authorities having jurisdiction.
 - 3. Minimum fireproofing thicknesses needed to achieve required fire-resistance rating of each structural component and assembly.
 - 4. Treatment of fireproofing after application.
- D. Samples: For each exposed product and for each color and texture specified, in manufacturer's standard dimensions.

1.4 INFORMATIONAL SUBMITTALS

- A. Qualification Data: For Installer.
- B. Product Certificates: For each type of fireproofing.
- C. Evaluation Reports: For fireproofing, from ICC-ES.

1.5 QUALITY ASSURANCE

- A. Installer Qualifications: A firm or individual certified, licensed, or otherwise qualified by fireproofing manufacturer as experienced and with sufficient trained staff to install manufacturer's products according to specified requirements..
- B. Mockups: Build mockups to demonstrate aesthetic effects and to set quality standards for materials and execution.
 - 1. Build mockup of each type of fireproofing and different substrate as shown on Drawings.
 - 2. Approval of mockups does not constitute approval of deviations from the Contract Documents contained in mockups unless Architect specifically approves such deviations in writing.
 - 3. Subject to compliance with requirements, approved mockups may become part of the completed Work if undisturbed at time of Substantial Completion.

1.7 PROJECT CONDITIONS

- A. Apply waterborne coatings only when temperatures of surfaces to be coated and surrounding air are between 50 and 90 deg F (10 and 32 deg C).
- B. Ventilation: Ventilate building spaces during and after application of fireproofing, providing complete air exchanges according to manufacturer's written instructions. Use natural means or, if they are inadequate, forced-air circulation until fireproofing dries thoroughly.

PART 2 - PRODUCTS

2.1 INTUMESCENT COATING MATERIALS, GENERAL

- A. Assemblies: Provide fireproofing, including auxiliary materials, according to requirements of each fire-resistance design and manufacturer's written instructions.
- B. Source Limitations: Obtain fireproofing from single source.
- C. Fire-Resistance Design: Indicated on Drawings, tested according to ASTM E 119 or UL 263 by a qualified testing agency. Identify products with appropriate markings of applicable testing agency.
 - 1. Steel members are to be considered unrestrained unless specifically noted otherwise
- D. Low-Emitting Materials: Products shall comply with VOC content limits of authorities having jurisdiction and the following VOC limits when calculated according to 40 CFR 59, Subpart D (EPA Method 24):
 - 1. Flat Paints and Coatings: 50 g/L.
 - 2. Nonflat Paints and Coatings: 150 g/L.
 - 3. Primers, Sealers, and Undercoaters: 200 g/L.
 - 4. Anticorrosive and Antirust Paints Applied to Ferrous Metals: 250 g/L.

- E. Asbestos: Provide products containing no detectable asbestos.

2.2 MASTIC AND INTUMESCENT FIRE-RESISTIVE COATINGS

- A. Mastic and Intumescent Fire-Resistive Coating: Manufacturer's standard, water-based, factory-mixed formulation, and complying with indicated fire-resistance design:
 - 1. Basis of Design Product: CAFCO SprayFilm WB 5 manufactured by Isolatek International, or the following equal (listed in the UL Designs indicated):
 - a. ISOLATEK Type WB 5 manufactured by Isolatek International
 - 2. Application: Designated for "interior general purpose" use by a qualified testing agency acceptable to authorities having jurisdiction.
 - 3. Thickness: As required for fire-resistance design indicated, measured according to requirements of fire-resistance design.
 - 4. Surface-Burning Characteristics: Comply with ASTM E 84; testing by a qualified testing agency. Identify products with appropriate markings of applicable testing agency.
 - a. Flame-Spread Index: 25 or less.
 - b. Smoke-Developed Index: 450 or less.
 - 5. Hardness: Not less than 80, Type D durometer, according to ASTM D 2240.
 - 6. VOC Content: Zero.
 - 7. UL Design No.:
 - a. Architecturally Exposed Steel Including Beams and Columns: UL X650, UL N614 for a one hour rating.
 - 8. Alternative Manufacturers: Subject to compliance with requirements, equal MIFRC products of the following manufacturers may be provided. Submit alternative UL Designs for approval prior to providing the alternative products.
 - a. Albi Manufacturing, Division of StanChem Inc.
 - b. Carbolite Company, subsidiary of RPM International, Fireproofing Products Div.
 - c. International Paint Limited, subsidiary of Akzo Nobel N. V.

2.3 AUXILIARY MATERIALS

- A. General: Provide auxiliary materials that are compatible with fireproofing and substrates and are approved by UL or another testing and inspecting agency acceptable to authorities having jurisdiction for use in fire-resistance designs indicated.
- B. Substrate Primers: Primers approved by fireproofing manufacturer and complying with required fire-resistance design by UL or another testing and inspecting agency acceptable to authorities having jurisdiction.
 - 1. Refer to Division 09 Section "Painting" for additional information on prime paint.
- C. Decorative Topcoat: Finish paint specified in Division 09 Section "Painting". Topcoat shall be suitable for application over applied fireproofing; of type recommended in writing by fireproofing manufacturer for each fire-resistance design.

PART 3 - EXECUTION

3.1 EXAMINATION

- A. Examine substrates, areas, and conditions, with Installer present, for compliance with requirements for substrates and other conditions affecting performance of the Work and according to each fire-resistance design. Verify compliance with the following:
 - 1. Substrates are free of dirt, oil, grease, release agents, rolling compounds, mill scale, loose scale, incompatible primers, paints, and encapsulants, or other foreign substances capable of impairing bond of fireproofing with substrates under conditions of normal use or fire exposure.
 - 2. Objects penetrating fireproofing, including clips, hangers, support sleeves, and similar items, are securely attached to substrates.
 - 3. Substrates receiving fireproofing are not obstructed by ducts, piping, equipment, or other suspended construction that will interfere with fireproofing application.
- B. Conduct tests according to fireproofing manufacturer's written recommendations to verify that substrates are free of substances capable of interfering with bond.
- C. Prepare written report, endorsed by Installer, listing conditions detrimental to performance of the Work.
- D. Proceed with installation only after unsatisfactory conditions have been corrected.

3.2 PREPARATION

- A. Cover other work subject to damage from fallout or overspray of fireproofing materials during application.
- B. Clean substrates of substances that could impair bond of fireproofing.
- C. Prime substrates where included in fire-resistance design and where recommended in writing by fireproofing manufacturer unless compatible shop primer has been applied and is in satisfactory condition to receive fireproofing.
- D. For applications visible on completion of Project, repair substrates to remove surface imperfections that could affect uniformity of texture and thickness in finished surface of fireproofing. Remove minor projections and fill voids that would telegraph through fire-resistive products after application.

3.3 APPLICATION

- A. Construct fireproofing assemblies that are identical to fire-resistance design indicated and products as specified, tested, and substantiated by test reports; for thickness, primers, topcoats, finishing, and other materials and procedures affecting fireproofing work.

- B. Comply with fireproofing manufacturer's written instructions for mixing materials, application procedures, and types of equipment used to mix, convey, and apply fireproofing; as applicable to particular conditions of installation and as required to achieve fire-resistance ratings indicated.
 - C. Coordinate application of fireproofing with other construction to minimize need to cut or remove fireproofing.
 - 1. Do not begin applying fireproofing until clips, hangers, supports, sleeves, and other items penetrating fireproofing are in place.
 - 2. Defer installing ducts, piping, and other items that would interfere with applying fireproofing until application of fireproofing is completed.
 - D. Install auxiliary materials as required, as detailed, and according to fire-resistance design and fireproofing manufacturer's written recommendations for conditions of exposure and intended use. For auxiliary materials, use attachment and anchorage devices of type recommended in writing by fireproofing manufacturer.
 - E. Spray apply fireproofing to maximum extent possible. Following the spraying operation in each area, complete the coverage by trowel application or other placement method recommended in writing by fireproofing manufacturer.
 - F. Extend fireproofing in full thickness over entire area of each substrate to be protected.
 - G. Install body of fireproofing in a single course unless otherwise recommended in writing by fireproofing manufacturer.
 - H. Provide a uniform finish complying with description indicated for each type of fireproofing material and matching finish approved for required mockups.
 - I. Cure fireproofing according to fireproofing manufacturer's written recommendations.
 - J. Do not install enclosing or concealing construction or apply finish paint coat until after fireproofing has been applied, inspected, and tested and corrections have been made to deficient applications.
 - K. Finishes: Apply fireproofing to produce surface finish matching approved mock-up.
 - L. Field Painting: Refer to Division 09 Section "Painting".
- 3.4 FIELD QUALITY CONTROL
- A. Special Inspections: Owner will engage a qualified special inspector to perform the following special inspections:
 - 1. Test and inspect as required by the IBC, 1704.11.
 - B. Perform the tests and inspections of completed Work in successive stages. Do not proceed with application of fireproofing for the next area until test results for previously completed applications of fireproofing show compliance with requirements. Tested

values must equal or exceed values as specified and as indicated and required for approved fire-resistance design.

- C. Fireproofing will be considered defective if it does not pass tests and inspections.
 - 1. Remove and replace fireproofing that does not pass tests and inspections, and retest.
 - 2. Apply additional fireproofing, per manufacturer's written instructions, where test results indicate insufficient thickness, and retest.
- D. Prepare test and inspection reports.

3.5 CLEANING, PROTECTING, AND REPAIRING

- A. Cleaning: Immediately after completing spraying operations in each containable area of Project, remove material overspray and fallout from surfaces of other construction and clean exposed surfaces to remove evidence of soiling.
- B. Protect fireproofing, according to advice of manufacturer and Installer, from damage resulting from construction operations or other causes, so fireproofing will be without damage or deterioration at time of Substantial Completion.
- C. As installation of other construction proceeds, inspect fireproofing and repair damaged areas and fireproofing removed due to work of other trades.
- D. Repair fireproofing damaged by other work before concealing it with other construction.
- E. Repair fireproofing by reapplying it using same method as original installation or using manufacturer's recommended trowel-applied product.

END OF SECTION 078123

SECTION 078413 - PENETRATION FIRESTOPPING

PART 1 - GENERAL

1.1 SUMMARY

A. Section Includes:

1. Penetrations in fire-resistance-rated walls.
2. Penetrations in fire-resistance-rate horizontal assemblies.
3. Penetrations in non-fire-resistance-rate horizontal assemblies.
4. Penetrations in smoke barriers, smoke partitions and smoke tight partitions.

B. Related Sections:

1. Section 078446 "Fire-Resistive Joint Systems" for joints in or between fire-resistance-rated construction, at exterior curtain-wall/floor intersections, and in smoke barriers.

1.2 ACTION SUBMITTALS

A. Product Data: For each type of product indicated.

B. Product Schedule: For each penetration firestopping system. Include location and design designation of qualified testing and inspecting agency.

1. Where Project conditions require modification to a qualified testing and inspecting agency's illustration for a particular penetration firestopping condition, submit illustration, with modifications marked, approved by penetration firestopping manufacturer's fire-protection engineer as an engineering judgment or equivalent fire-resistance-rated assembly.

1.3 INFORMATIONAL SUBMITTALS

A. Qualification Data: For qualified Installer.

B. Installer Certificates: From Installer indicating penetration firestopping has been installed in compliance with requirements and manufacturer's written recommendations.

C. Product Test Reports: Based on evaluation of comprehensive tests performed by a qualified testing agency, for penetration firestopping.

1.4 QUALITY ASSURANCE

A. Installer Qualifications: A firm experienced in installing penetration firestopping similar in material, design, and extent to that indicated for this Project, whose work has resulted in construction with a record of successful performance. Qualifications include

having the necessary experience, staff, and training to install manufacturer's products per specified requirements. Manufacturer's willingness to sell its penetration firestopping products to Contractor or to Installer engaged by Contractor does not in itself confer qualification on buyer.

- B. Fire-Test-Response Characteristics: Penetration firestopping shall comply with the following requirements:
1. Penetration firestopping tests are performed by a qualified testing agency acceptable to authorities having jurisdiction.
 2. Penetration firestopping is identical to those tested per testing standard referenced in "Penetration Firestopping" Article. Provide rated systems complying with the following requirements:
 - a. Penetration firestopping products bear classification marking of qualified testing and inspecting agency.
 - b. Classification markings on penetration firestopping correspond to designations listed by the following:
 - 1) UL in its "Fire Resistance Directory."
 - 2) Intertek ETL SEMKO in its "Directory of Listed Building Products."
 - 3) FM Global in its "Building Materials Approval Guide."
- C. Preinstallation Conference: Conduct conference at Project site.

1.5 PROJECT CONDITIONS

- A. Environmental Limitations: Do not install penetration firestopping when ambient or substrate temperatures are outside limits permitted by penetration firestopping manufacturers or when substrates are wet because of rain, frost, condensation, or other causes.
- B. Install and cure penetration firestopping per manufacturer's written instructions using natural means of ventilations or, where this is inadequate, forced-air circulation.

1.6 COORDINATION

- A. Coordinate construction of openings and penetrating items to ensure that penetration firestopping is installed according to specified requirements.
- B. Coordinate sizing of sleeves, openings, core-drilled holes, or cut openings to accommodate penetration firestopping.
- C. Notify Owner's testing agency at least seven days in advance of penetration firestopping installations; confirm dates and times on day preceding each series of installations.

PART 2 - PRODUCTS

2.1 MANUFACTURERS

- A. Manufacturers: Subject to compliance with requirements, available manufacturers offering products that may be incorporated into the Work include, but are not limited to, the following:
1. Penetration Firestop Systems specified in the Schedule in Part - 3 include:
 - a. Fire Barrier Products, 3M Fire Protection Products
 - b. RectorSeal Corporation.
 2. Subject to compliance with specified requirements, provide Penetration Firestop Systems (XHEZ) listed in Volume II of the UL Fire Resistance Directory (BXRH), by one of the following:
 - a. Hilti, Inc.
 - b. Nelson Firestop Products.
 - c. RectorSeal Corporation.
 - d. Specified Technologies Inc.
 - e. 3M Fire Protection Products.
 - f. Wiremold/Legrand

2.2 PENETRATION FIRESTOPPING

- A. Provide penetration firestopping that is produced and installed to resist spread of fire according to requirements indicated, resist passage of smoke and other gases, and maintain original fire-resistance rating of construction penetrated. Penetration firestopping systems shall be compatible with one another, with the substrates forming openings, and with penetrating items if any.
- B. Penetrations in Fire-Resistance-Rated Walls: Provide penetration firestopping with ratings determined per ASTM E 814 or UL 1479, based on testing at a positive pressure differential of 0.01-inch wg (2.49 Pa).
1. Fire-resistance-rated walls include fire walls, fire-barrier walls, smoke-barrier walls, and fire partitions.
 2. F-Rating: Not less than the fire-resistance rating of constructions penetrated.
- C. Penetrations in Horizontal Assemblies: Provide penetration firestopping with ratings determined per ASTM E 814 or UL 1479, based on testing at a positive pressure differential of 0.01-inch wg (2.49 Pa).
1. Horizontal assemblies include floors and floor/ceiling assemblies.
 2. F-Rating: At least 1 hour, but not less than the fire-resistance rating of constructions penetrated.
 3. T-Rating: At least 1 hour, but not less than the fire-resistance rating of constructions penetrated except for floor penetrations within the cavity of a wall.
- D. Penetrations in Smoke Barriers: Provide penetration firestopping with ratings determined per UL 1479.
1. L-Rating: Not exceeding 5.0 cfm/sq. ft. (0.025 cu. m/s per sq. m) of penetration opening at 0.30-inch wg (74.7 Pa) at both ambient and elevated temperatures.

- E. W-Rating: Provide penetration firestopping showing no evidence of water leakage when tested according to UL 1479.
- F. Exposed Penetration Firestopping: Provide products with flame-spread and smoke-developed indexes of less than 25 and 450, respectively, as determined per ASTM E 84.
- G. VOC Content: Penetration firestopping sealants and sealant primers shall comply with the following limits for VOC content when calculated according to 40 CFR 59, Subpart D (EPA Method 24):
 - 1. Sealants: 250 g/L.
 - 2. Sealant Primers for Nonporous Substrates: 250 g/L.
 - 3. Sealant Primers for Porous Substrates: 775 g/L.
- H. Accessories: Provide components for each penetration firestopping system that are needed to install fill materials and to maintain ratings required. Use only those components specified by penetration firestopping manufacturer and approved by qualified testing and inspecting agency for firestopping indicated.
 - 1. Permanent forming/damming/backing materials, including the following:
 - a. Slag-wool-fiber or rock-wool-fiber insulation.
 - b. Sealants used in combination with other forming/damming/backing materials to prevent leakage of fill materials in liquid state.
 - c. Fire-rated form board.
 - d. Fillers for sealants.
 - 2. Temporary forming materials.
 - 3. Substrate primers.
 - 4. Collars.
 - 5. Steel sleeves.

2.3 FILL MATERIALS

- A. Cast-in-Place Firestop Devices: Factory-assembled devices for use in cast-in-place concrete floors and consisting of an outer metallic sleeve lined with an intumescent strip, a radial extended flange attached to one end of the sleeve for fastening to concrete formwork, and a neoprene gasket.
- B. Latex Sealants: Single-component latex formulations that do not re-emulsify after cure during exposure to moisture.
- C. Firestop Devices: Factory-assembled collars formed from galvanized steel and lined with intumescent material sized to fit specific diameter of penetrant.
- D. Intumescent Composite Sheets: Rigid panels consisting of aluminum-foil-faced elastomeric sheet bonded to galvanized-steel sheet.
- E. Intumescent Putties: Nonhardening dielectric, water-resistant putties containing no solvents, inorganic fibers, or silicone compounds.

- F. Intumescent Wrap Strips: Single-component intumescent elastomeric sheets with aluminum foil on one side.
- G. Mortars: Prepackaged dry mixes consisting of a blend of inorganic binders, hydraulic cement, fillers, and lightweight aggregate formulated for mixing with water at Project site to form a nonshrinking, homogeneous mortar.
- H. Pillows/Bags: Reusable heat-expanding pillows/bags consisting of glass-fiber cloth cases filled with a combination of mineral-fiber, water-insoluble expansion agents, and fire-retardant additives. Where exposed, cover openings with steel-reinforcing wire mesh to protect pillows/bags from being easily removed.
- I. Silicone Foams: Multicomponent, silicone-based liquid elastomers that, when mixed, expand and cure in place to produce a flexible, nonshrinking foam.
- J. Silicone Sealants: Single-component, silicone-based, neutral-curing elastomeric sealants of grade indicated below:
 - 1. Grade: Pourable (self-leveling) formulation for openings in floors and other horizontal surfaces, and nonsag formulation for openings in vertical and sloped surfaces, unless indicated firestopping limits use of nonsag grade for both opening conditions.

2.4 MIXING

- A. For those products requiring mixing before application, comply with penetration firestopping manufacturer's written instructions for accurate proportioning of materials, water (if required), type of mixing equipment, selection of mixer speeds, mixing containers, mixing time, and other items or procedures needed to produce products of uniform quality with optimum performance characteristics for application indicated.

PART 3 - EXECUTION

3.1 EXAMINATION

- A. Examine substrates and conditions, with Installer present, for compliance with requirements for opening configurations, penetrating items, substrates, and other conditions affecting performance of the Work.
- B. Proceed with installation only after unsatisfactory conditions have been corrected.

3.2 PREPARATION

- A. Surface Cleaning: Clean out openings immediately before installing penetration firestopping to comply with manufacturer's written instructions and with the following requirements:
 - 1. Remove from surfaces of opening substrates and from penetrating items foreign materials that could interfere with adhesion of penetration firestopping.

2. Clean opening substrates and penetrating items to produce clean, sound surfaces capable of developing optimum bond with penetration firestopping. Remove loose particles remaining from cleaning operation.
 3. Remove laitance and form-release agents from concrete.
- B. Priming: Prime substrates where recommended in writing by manufacturer using that manufacturer's recommended products and methods. Confine primers to areas of bond; do not allow spillage and migration onto exposed surfaces.
- C. Masking Tape: Use masking tape to prevent penetration firestopping from contacting adjoining surfaces that will remain exposed on completion of the Work and that would otherwise be permanently stained or damaged by such contact or by cleaning methods used to remove stains. Remove tape as soon as possible without disturbing firestopping's seal with substrates.

3.3 INSTALLATION

- A. General: Install penetration firestopping to comply with manufacturer's written installation instructions and published drawings for products and applications indicated.
- B. Install forming materials and other accessories of types required to support fill materials during their application and in the position needed to produce cross-sectional shapes and depths required to achieve fire ratings indicated.
1. After installing fill materials and allowing them to fully cure, remove combustible forming materials and other accessories not indicated as permanent components of firestopping.
- C. Install fill materials for firestopping by proven techniques to produce the following results:
1. Fill voids and cavities formed by openings, forming materials, accessories, and penetrating items as required to achieve fire-resistance ratings indicated.
 2. Apply materials so they contact and adhere to substrates formed by openings and penetrating items.
 3. For fill materials that will remain exposed after completing the Work, finish to produce smooth, uniform surfaces that are flush with adjoining finishes.

3.4 IDENTIFICATION

- A. Identify penetration firestopping with preprinted metal or plastic labels. Attach labels permanently to surfaces adjacent to and within 6 inches (150 mm) of firestopping edge so labels will be visible to anyone seeking to remove penetrating items or firestopping. Use mechanical fasteners or self-adhering-type labels with adhesives capable of permanently bonding labels to surfaces on which labels are placed. Include the following information on labels:
1. The words "Warning - Penetration Firestopping - Do Not Disturb. Notify Building Management of Any Damage."
 2. Contractor's name, address, and phone number.

3. Designation of applicable testing and inspecting agency.
4. Date of installation.
5. Manufacturer's name.
6. Installer's name.

3.5 FIELD QUALITY CONTROL

- A. Owner will engage a qualified testing agency to perform tests and inspections.
- B. Where deficiencies are found or penetration firestopping is damaged or removed because of testing, repair or replace penetration firestopping to comply with requirements.
- C. Proceed with enclosing penetration firestopping with other construction only after inspection reports are issued and installations comply with requirements.

3.6 CLEANING AND PROTECTION

- A. Clean off excess fill materials adjacent to openings as the Work progresses by methods and with cleaning materials that are approved in writing by penetration firestopping manufacturers and that do not damage materials in which openings occur.
- B. Provide final protection and maintain conditions during and after installation that ensure that penetration firestopping is without damage or deterioration at time of Substantial Completion. If, despite such protection, damage or deterioration occurs, immediately cut out and remove damaged or deteriorated penetration firestopping and install new materials to produce systems complying with specified requirements.

3.7 PENETRATION FIRESTOPPING SCHEDULE

- A. Where UL-classified systems are indicated, they refer to system numbers in UL's "Fire Resistance Directory" under product Category XHEZ.
- B. For penetrations in non-fire rated horizontal assemblies, smoke barriers, smoke partitions and smoke tight partitions, provide systems tested for 1 hour unless otherwise noted.
- C. Basis of Design Assemblies: Subject to compliance with requirements, provide the design indicated below or a comparable UL design by one of manufacturer's listed in Part 2 above.
 1. Schedule of construction components, type of penetrant, and U.L. Penetration Firestop Systems include, but are not limited to the following:
 2. Schedule of construction components, type of penetrant, and U.L. Penetration Firestop Systems include, but are not limited to the following:

	P E N E T R A N T
--	--------------------------

	Metal Conduit	Cable Tray⁴	Cables	Non-Insul. Metal Pipe	Insul. Pipe	FR Polypropylene Pipe	Insul. Metal Duct
GWB Stud Wall, or Shaft Wall up to 2 Hr Rating	W-L-1001	W-L-4004	W-L-3001	W-L-1001	W-L-5011	W-L-2002	W-L-7006 ³
CMU Wall up to 2 Hr Rating	C-AJ-1044	C-AJ-4003	C-AJ-3030	C-AJ-1044	C-AJ-5001	C-AJ-2001	C-AJ-7003 ³ , 7016 ³
Concrete Floor / Metal Deck 1 Hr Rated F and T-Rating²	C-AJ-1008	N/A	C-AJ-3029	C-AJ-1008	C-AJ-5002	F-A-2002	C-AJ-7009 ⁵
Concrete Floor / Metal Deck 2 Hr Rated F and T-Rating²	C-AJ-1008	N/A	C-AJ-3029	C-AJ-1008	C-AJ-5060	F-A-2002	N/A
Concrete Floor / Metal Deck up to 2 Hr F Rated¹	F-A-1002	N/A	C-AJ-3030	C-AJ-1044	C-AJ-5001	F-A-2002	N/A

KEY TO NOTES

1. Penetration within wall cavity.
2. Penetration that does not fall within wall cavity, T-Rating required.
3. Up to 1 hour rating, submit engineered judgement firestopping system for this combination of penetrant, wall/floor assembly, and fire rating. Install fire dampers in 2-hour walls in accordance with manufacturer's instructions and testing agency requirements.
4. Where cable tray extends through wall.
5. For floor penetrations not enclosed above and below the floor with shaft wall.

D. Membrane Penetrations:

1. Firestop membrane penetrations by cables, pipes and conduit similar to through wall penetrations.
 2. Provide putty pad box wrap firestopping for membrane penetrations in rated walls for electrical back boxes over 16 sq. inches, where any back boxes are located within 24 inches horizontal of another back box, or when total area of back boxes exceeds 100 sq in. in 100 sq. ft. of wall area.
- E. Where another type of construction or penetrant is encountered, or if field conditions vary from those described in the U.L. System listed (i.e. annular space is greater/smaller, insulation type varies, etc.), provide firestopping systems which are appropriate, and U.L. tested, for that condition.

END OF SECTION 078413

SECTION 078446 - FIRE-RESISTIVE JOINT SYSTEMS

PART 1 - GENERAL

1.1 SUMMARY

A. Section Includes:

1. Joints in or between fire-resistance-rated constructions.
2. Joints in smoke barriers.

B. Related Sections:

1. Section 078413 "Penetration Firestopping" for penetrations in fire-resistance-rated walls, horizontal assemblies, and smoke barriers.

1.2 ACTION SUBMITTALS

A. Product Data: For each type of product indicated.

B. Product Schedule: For each fire-resistive joint system. Include location and design designation of qualified testing agency.

1. Where Project conditions require modification to a qualified testing agency's illustration for a particular fire-resistive joint system condition, submit illustration, with modifications marked, approved by fire-resistive joint system manufacturer's fire-protection engineer as an engineering judgment or equivalent fire-resistance-rated assembly.

1.3 INFORMATIONAL SUBMITTALS

A. Qualification Data: For qualified Installer.

B. Installer Certificates: From Installer indicating fire-resistive joint systems have been installed in compliance with requirements and manufacturer's written recommendations.

C. Product Test Reports: Based on evaluation of comprehensive tests performed by a qualified testing agency, for fire-resistive joint systems.

1.4 QUALITY ASSURANCE

A. Installer Qualifications: A firm experienced in installing fire-resistive joint systems similar in material, design, and extent to that indicated for this Project, whose work has resulted in construction with a record of successful performance. Qualifications include having the necessary experience, staff, and training to install manufacturer's products per specified requirements. Manufacturer's willingness to sell its fire-resistive joint

system products to Contractor or to Installer engaged by Contractor does not in itself confer qualification on buyer.

- B. Fire-Test-Response Characteristics: Fire-resistive joint systems shall comply with the following requirements:
 - 1. Fire-resistive joint system tests are performed by a qualified testing agency acceptable to authorities having jurisdiction.
 - 2. Fire-resistive joint systems are identical to those tested per testing standard referenced in "Fire-Resistive Joint Systems" Article. Provide rated systems complying with the following requirements:
 - a. Fire-resistive joint system products bear classification marking of qualified testing agency.
 - b. Fire-resistive joint systems correspond to those indicated by reference to designations listed by the following:
 - 1) UL in its "Fire Resistance Directory."
- C. Preinstallation Conference: Conduct conference at Project site.

1.5 PROJECT CONDITIONS

- A. Environmental Limitations: Do not install fire-resistive joint systems when ambient or substrate temperatures are outside limits permitted by fire-resistive joint system manufacturers or when substrates are wet due to rain, frost, condensation, or other causes.
- B. Install and cure fire-resistive joint systems per manufacturer's written instructions using natural means of ventilation or, where this is inadequate, forced-air circulation.

1.6 COORDINATION

- A. Coordinate construction of joints to ensure that fire-resistive joint systems are installed according to specified requirements.
- B. Coordinate sizing of joints to accommodate fire-resistive joint systems.
- C. Notify Owner's testing agency at least seven days in advance of fire-resistive joint system installations; confirm dates and times on day preceding each series of installations.

PART 2 - PRODUCTS

2.1 FIRE-RESISTIVE JOINT SYSTEMS

- A. Where required, provide fire-resistive joint systems that are produced and installed to resist spread of fire according to requirements indicated, resist passage of smoke and other gases, and maintain original fire-resistance rating of assemblies in or between which fire-resistive joint systems are installed. Fire-resistive joint systems shall

accommodate building movements without impairing their ability to resist the passage of fire and hot gases.

- B. Joints in or between Fire-Resistance-Rated Construction: Provide fire-resistive joint systems with ratings determined per ASTM E 1966 or UL 2079:
1. Joints include those installed in or between fire-resistance-rated walls, floor or floor/ceiling assemblies and roofs or roof/ceiling assemblies.
 2. Fire-Resistance Rating: Equal to or exceeding the fire-resistance rating of construction they will join.
 3. Manufacturers: Subject to compliance with requirements, available manufacturers offering products that may be incorporated into the Work include, but are not limited to, the following:
 - a. Grace Construction Products.
 - b. Hilti, Inc.
 - c. RectorSeal Corporation.
 - d. Specified Technologies Inc.
 - e. 3M Fire Protection Products.
 - f. Tremco, Inc.; Tremco Fire Protection Systems Group.
- C. Joints in Smoke Barriers: Provide fire-resistive joint systems with ratings determined per UL 2079.
1. L-Rating: Not exceeding 5.0 cfm/ft (0.00775 cu. m/s x m) of joint at 0.30 inch wg (74.7 Pa) at both ambient and elevated temperatures.
 2. Manufacturers: Subject to compliance with requirements, available manufacturers offering products that may be incorporated into the Work include, but are not limited to, the following:
 - a. Grace Construction Products.
 - b. Hilti, Inc.
 - c. Johns Manville.
 - d. RectorSeal Corporation.
 - e. Specified Technologies Inc.
 - f. 3M Fire Protection Products.
 - g. Tremco, Inc.; Tremco Fire Protection Systems Group.
- D. Exposed Fire-Resistive Joint Systems: Provide products with flame-spread and smoke-developed indexes of less than 25 and 450, respectively, as determined per ASTM E 84.
- E. VOC Content: Fire-resistive joint system sealants shall comply with the following limits for VOC content when calculated according to 40 CFR 59, Subpart D (EPA Method 24):
1. Architectural Sealants: 250 g/L.
 2. Sealant Primers for Nonporous Substrates: 250 g/L.
 3. Sealant Primers for Porous Substrates: 775 g/L.
- F. Accessories: Provide components of fire-resistive joint systems, including primers and forming materials, that are needed to install fill materials and to maintain ratings

required. Use only components specified by fire-resistive joint system manufacturer and approved by the qualified testing agency for systems indicated.

PART 3 - EXECUTION

3.1 EXAMINATION

- A. Examine substrates and conditions, with Installer present, for compliance with requirements for joint configurations, substrates, and other conditions affecting performance of the Work.
- B. Proceed with installation only after unsatisfactory conditions have been corrected.

3.2 PREPARATION

- A. Surface Cleaning: Clean joints immediately before installing fire-resistive joint systems to comply with fire-resistive joint system manufacturer's written instructions and the following requirements:
 - 1. Remove from surfaces of joint substrates foreign materials that could interfere with adhesion of fill materials.
 - 2. Clean joint substrates to produce clean, sound surfaces capable of developing optimum bond with fill materials. Remove loose particles remaining from cleaning operation.
 - 3. Remove laitance and form-release agents from concrete.
- B. Priming: Prime substrates where recommended in writing by fire-resistive joint system manufacturer using that manufacturer's recommended products and methods. Confine primers to areas of bond; do not allow spillage and migration onto exposed surfaces.
- C. Masking Tape: Use masking tape to prevent fill materials of fire-resistive joint system from contacting adjoining surfaces that will remain exposed on completion of the Work and that would otherwise be permanently stained or damaged by such contact or by cleaning methods used to remove stains. Remove tape as soon as possible without disturbing fire-resistive joint system's seal with substrates.

3.3 INSTALLATION

- A. General: Install fire-resistive joint systems to comply with manufacturer's written installation instructions and published drawings for products and applications indicated.
- B. Install forming materials and other accessories of types required to support fill materials during their application and in position needed to produce cross-sectional shapes and depths required to achieve fire ratings indicated.
 - 1. After installing fill materials and allowing them to fully cure, remove combustible forming materials and other accessories not indicated as permanent components of fire-resistive joint system.

- C. Install fill materials for fire-resistive joint systems by proven techniques to produce the following results:
 - 1. Fill voids and cavities formed by joints and forming materials as required to achieve fire-resistance ratings indicated.
 - 2. Apply fill materials so they contact and adhere to substrates formed by joints.
 - 3. For fill materials that will remain exposed after completing the Work, finish to produce smooth, uniform surfaces that are flush with adjoining finishes.

3.4 IDENTIFICATION

- A. Identify fire-resistive joint systems with preprinted metal or plastic labels. Attach labels permanently to surfaces adjacent to and within 6 inches (150 mm) of joint edge so labels will be visible to anyone seeking to remove or penetrate joint system. Use mechanical fasteners or self-adhering-type labels with adhesives capable of permanently bonding labels to surfaces on which labels are placed. Include the following information on labels:
 - 1. The words "Warning - Fire-Resistive Joint System - Do Not Disturb. Notify Building Management of Any Damage."
 - 2. Contractor's name, address, and phone number.
 - 3. Designation of applicable testing agency.
 - 4. Date of installation.
 - 5. Manufacturer's name.
 - 6. Installer's name.

3.5 FIELD QUALITY CONTROL

- A. Inspecting Agency: Owner will engage a qualified testing agency to perform tests and inspections.
- B. Where deficiencies are found or fire-resistive joint systems are damaged or removed due to testing, repair or replace fire-resistive joint systems so they comply with requirements.
- C. Proceed with enclosing fire-resistive joint systems with other construction only after inspection reports are issued and installations comply with requirements.

3.6 CLEANING AND PROTECTING

- A. Clean off excess fill materials adjacent to joints as the Work progresses by methods and with cleaning materials that are approved in writing by fire-resistive joint system manufacturers and that do not damage materials in which joints occur.
- B. Provide final protection and maintain conditions during and after installation that ensure fire-resistive joint systems are without damage or deterioration at time of Substantial Completion. If damage or deterioration occurs despite such protection, cut out and remove damaged or deteriorated fire-resistive joint systems immediately and install new materials to produce fire-resistive joint systems complying with specified requirements.

3.7 FIRE-RESISTIVE JOINT SYSTEM / FIRESTOP JOINT SYSTEM SCHEDULE

A. Where UL-classified firestop joint systems are indicated, they refer to alphanumeric designations listed in UL's "Fire Resistance Directory" under product Category XHBN.

Firestop Joint System Location	Basis-of-Design	Assembly Rating	Nominal Joint Width	Movement Capabilities ²
Floor-to-Wall				
Rated concrete masonry wall construction intersection with adjacent floor construction	FW-D-1012, FW-D-1013	1 hour or 2 hours ¹	As indicated, or required by tested assembly	Class II
Head-of-Wall				
Rated gypsum wall construction intersection with steel floor deck above	HW-D-0087, or HW-D-0089	1 hour or 2 hours ¹	As indicated, or required by tested assembly	Class II or III,
Rated gypsum wall construction intersection with concrete floor deck above	HW-D-0083, HW-D-209	1 hour or 2 hours ¹	As indicated, or required by tested assembly	Class II
Rated concrete masonry wall construction intersection with steel floor deck above	HW-D-0081, or HW-D-0098	1 hour or 2 hours ¹	As indicated, or required by tested assembly	Class II
Rated concrete masonry wall construction intersection with concrete floor deck above	HW-D-0268, HW-D-0097	1 hour or 2 hours ¹	As indicated, or required by tested assembly	Class II
Bottom-of-Wall				
Rated gypsum wall construction intersection with concrete floor	BW-S-0002	1 hour or 2 hours ¹	As indicated, or required by tested assembly	Static

1. Rating to match wall construction.
2. Class UL2079

B. Where another type of construction is encountered, or if field conditions vary from those described in the U.L. System listed (i.e. annular space is greater/smaller,

13 January 2022
Conformed Specifications
SED #66-23-00-01-0-346-001

Yonkers Joint Schools Construction Board
Community School 35

insulation type varies, etc.), provide firestopping systems which are appropriate, and U.L. tested, for that condition.

END OF SECTION 078446

ATTACHMENT: FIRESTOP JOINT SYSTEMS SUBMITTAL SHEET

3.8 FIRESTOP JOINT SYSTEMS SUBMITTAL SHEET

A. **HEAD-OF-WALL FIRESTOPPING:** Fill in the U.L. Design number and attach copy of U.L. Test. Insert n/a if condition is not applicable.

1. Gypsum wall construction intersection with floor deck above: _____.
Gypsum wall construction intersection with roof deck above: _____.
2. Concrete masonry wall construction intersection with floor deck above:
_____.
3. Concrete masonry wall construction intersection with roof deck above:
_____.

B. **FLOOR-TO-WALL FIRESTOPPING:** Fill in the U.L. Design number and attach copy of U.L. Test. Insert n/a if condition is not applicable.

1. Concrete masonry wall construction intersection with adjacent floor construction:
_____.

C. **BOTTOM-OF-WALL FIRESTOPPING:** Fill in the U.L. Design number and attach copy of U.L. Test. Insert n/a if condition is not applicable.

1. Gypsum wall construction intersection with floor deck: _____. Gypsum wall construction intersection with roof deck above: _____.
2. Concrete masonry wall construction intersection with floor _____.
3. Concrete masonry wall construction intersection with roof deck above:
_____.

D. **CURTAIN WALL FIRESTOPPING:** Fill in the design number and copy test. Insert n/a if condition is not applicable.

1. Aluminum mullion and glass spandrel panel curtainwall intersection with adjacent floor construction:
2. Gypsum sheathed curtainwall intersection with adjacent floor construction:
_____.

E. **OTHER:** Where another type of construction or penetrant is encountered, attach a separate sheet listing each condition and attach copy of the U.L. Test.

SECTION 079200 - JOINT SEALANTS

PART 1 - GENERAL

1.1 SUMMARY

- A. This Section includes joint sealants for the following locations:
1. Exterior joints in the following vertical surfaces and nontraffic horizontal surfaces:
 - a. Control and expansion joints in cast-in-place concrete
 - b. Joints in brick veneer wall surfaces.
 - c. Joints in stone veneer wall surfaces.
 - d. Joints at cast stone units.
 - e. Joints in EIFS wall panels.
 - f. Joints in composite metal wall panels.
 - g. Joints in sheet metal wall panels.
 - h. Joints between different materials listed above
 - i. Perimeter joints between materials listed above and frames of aluminum entrance and storefront framing, aluminum curtainwall framing and frames of doors, louvers and windows.
 - j. Control and expansion joints in ceiling and overhead surfaces.
 - k. Other joints as indicated.
 2. Exterior joints in the following horizontal traffic surfaces:
 - a. Control, expansion, and isolation joints in cast-in-place concrete slabs.
 - b. Other joints as indicated.
 3. Interior joints in the following vertical surfaces and horizontal nontraffic surfaces:
 - a. Control and expansion joints on exposed interior surfaces of exterior walls.
 - b. Perimeter joints of exterior openings where indicated.
 - c. Vertical control joints on exposed surfaces of interior unit masonry and concrete walls and partitions.
 - d. Perimeter joints between interior wall surfaces and frames of interior doors, windows, storefront and entrance framing, curtainwall framing, and elevator and wheelchair lift entrances.
 - e. Joints between plumbing fixtures and adjoining walls, floors, and counters.
 - f. Tile control and expansion joints
 - g. Openings and joints in sound-rated partitions.
 - h. Other joints as indicated.
 4. Interior joints in the following horizontal traffic surfaces:
 - a. Control and expansion joints in tile flooring.
 - b. Control and expansion joints in cast-in-place concrete slabs.

c. Other joints as indicated.

B. Related Sections include the following:

1. Sealants used in glazing are specified in Division 08 "Glazing."
2. Coordinate work of this section with all sections referencing it.

1.2 SYSTEM PERFORMANCE REQUIREMENTS

- A. Provide elastomeric joint sealants that establish and maintain watertight and airtight continuous joint seals without staining or deteriorating joint substrates.
- B. Provide joint sealants for interior applications that establish and maintain airtight and water-resistant continuous joint seals without staining or deteriorating joint substrates.

1.3 ACTION SUBMITTALS

- A. Product Data: For each joint-sealant product indicated.
- B. Samples for initial selection purposes in form of manufacturer's standard bead samples, consisting of strips of actual products showing full range of colors available, for each product exposed to view.
- C. Samples for verification purposes of each type and color of joint sealant required. Install joint sealant samples in 1/2-inch (13-mm) wide joints formed between two 6-inch (150-mm) long strips of material matching the appearance of exposed surfaces adjacent to joint sealants.

1.4 INFORMATIONAL SUBMITTALS

- A. Certificates from manufacturers of joint sealants attesting that their products comply with specification requirements and are suitable for the use indicated.
- B. Qualification data complying with requirements specified in "Quality Assurance" article. Include list of completed projects with project names addresses, names of Architects and Owners, plus other information specified.
- C. Compatibility and adhesion test reports from elastomeric sealant manufacturer indicating that materials forming joint substrates and joint sealant backings have been tested for compatibility and adhesion with joint sealants. Include sealant manufacturer's interpretation of test results relative to sealant performance and recommendations for primers and substrate preparation needed to obtain adhesion.
- D. Product test reports for each type of joint sealants indicated, evidencing compliance with requirements specified.
- E. Preconstruction field test reports indicating which products and joint preparation methods demonstrate acceptable adhesion to joint substrates.

- F. Warranties: Special warranties specified in this Section.

1.5 QUALITY ASSURANCE

- A. Installer Qualifications: Engage an installer who has successfully completed at least three (3) joint sealer applications similar in type and size to that of this project within the last five (5) years. All workers used for work of this Section shall be experienced in the techniques of sealant application and shall be completely familiar with the published recommendations of the manufacturer of the joint sealant materials being used.
- B. Source Limitations: Obtain each type of joint sealant through one source from a single manufacturer.
- C. Preconstruction Field Testing: Prior to installation of joint sealants, field-test their adhesion to joint substrates as follows:
 - 1. Locate test joints where indicated or, if not indicated, as directed by Architect.
 - 2. Conduct field tests for each application indicated below:
 - a. Each type of elastomeric sealant and joint substrate indicated.
 - b. Each type of non-elastomeric sealant and joint substrate indicated.
 - 3. Notify Architect one week in advance of the dates and times when mock-ups will be erected.
 - 4. Arrange for tests to take place with joint sealant manufacturer's technical representative present.
 - 5. Test Method: Test joint sealants by hand pull method described below:
 - a. Install joint sealants in 60 inches (1500 mm)) joint lengths using same materials and methods for joint preparation and joint sealant installation required for completed Work. Allow sealants to cure fully before testing.
 - b. Make knife cuts horizontally from one side of joint to the other followed by 2 vertical cuts approximately 2 inches (50 mm) long at side of joint and meeting horizontal cut at top of 2-inch (50-mm) cuts. Place a mark 1 inch (25 mm) from top of 2-inch (50-mm) piece.
 - c. Use fingers to grasp 2-inch (50-mm) piece of sealant just above 1-inch (25-mm) mark; pull firmly down at a 90-degree angle or more while holding a ruler along side of sealant. Pull sealant out of joint to the distance recommended by sealant manufacturer for testing adhesive capability, but not less than that equaling specified maximum movement capability in extension; hold this position for 10 seconds.
 - 6. Report whether or not sealant in joint connected to pulled-out portion failed to adhere to joint substrates or tore cohesively. Include data on pull distance used to test each type of product and joint substrate.
 - 7. Evaluation of Field Test Results: Sealants not evidencing adhesive failure from testing, in absence of other indications of noncompliance with requirements, will be considered satisfactory. Do not use sealants that fail to adhere to joint substrates during testing.

- D. Field-Constructed Mock-Ups: Prior to installation of joint sealants, apply elastomeric sealants as follows to verify selections made under sample submittals and to demonstrate aesthetic effects as well as qualities of materials and execution:
 - 1. Joints in field-constructed mock-ups of assemblies specified in other Sections that are indicated to receive elastomeric joint sealants specified in this Section.
- E. Pre-Installation Conference: Conduct conference at Project site to comply with requirements of the Division 01 Section covering this activity.
- F. Random Field Tests: Periodically test sealants, in place, for adhesion, using methods recommended by sealant manufacturer. Promptly replace any sealant that does not adhere, fails to cure, or fails to perform as specified by the sealant manufacturer.
- G. Field Water Test: Perform two field water tests on completed areas including as many conditions as possible. If leakage occurs during testing, repair as required, and re-test area and also test two additional locations.

1.6 DELIVERY, STORAGE, AND HANDLING

- A. Deliver materials to Project site in original unopened containers or bundles with labels indicating manufacturer, product name and designation, color, expiration period for use, pot life, curing time, and mixing instructions for multicomponent materials.
- B. Store and handle materials in compliance with manufacturer's recommendations to prevent their deterioration or damage due to moisture, high or low temperatures, contaminants, or other causes.

1.7 PROJECT CONDITIONS

- A. Environmental Conditions: Do not proceed with installation of joint sealants under the following conditions:
 - 1. When ambient and substrate temperature conditions are outside the limits permitted by joint sealant manufacturer or below 40 deg F (4 deg C).
 - 2. When joint substrates are wet.
- B. Joint Width Conditions: Do not proceed with installation of joint sealants where joint widths are less than allowed by joint sealant manufacturer for application indicated.
- C. Joint Substrate Conditions: Do not proceed with installation of joint sealants until contaminants capable of interfering with their adhesion are removed from joint substrates.

1.8 COORDINATION

- A. Coordinate the work with all sections referencing this section.

1.9 WARRANTY

- A. Special Installer's Warranty: Installer's standard form in which Installer agrees to repair or replace elastomeric joint sealants that do not comply with performance and other requirements specified in this Section within specified warranty period.
 - 1. Warranty Period: Two years from date of Substantial Completion.
- B. Manufacturer's Warranty: Provide written warranty agreeing to repair or replace, at no cost to Owner, defective materials for twenty (20) years, and workmanship for two (2) years from the Date of Substantial Completion. Defective materials and workmanship shall include, but are not limited to:
 - 1. Deterioration, aging or weathering of the work;
 - 2. Water leakage and/or air leakage;
 - 3. Sealant loss of adhesion, loss of cohesion, cracking or discoloration;
 - 4. Staining or discoloration of adjacent surfaces;
 - 5. Joint failure due to building or joint movement up to the limits prescribed by the manufacturer;
 - 6. Cracks or bubbles on sealant surface.

PART 2 - PRODUCTS

2.1 MATERIALS, GENERAL

- A. Compatibility: Provide joint sealants, joint fillers, and other related materials that are compatible with one another and with joint substrates under conditions of service and application, as demonstrated by sealant manufacturer based on testing and field experience.
- B. Colors: Provide color of exposed joint sealants to comply with the following:
 - 1. Provide selections made by Architect from manufacturer's standards or custom colors to match Architect's samples, as directed by Architect.
- C. Additional Movement Capability: Where additional movement capability is specified, provide products with the capability, when tested for adhesion and cohesion under maximum cyclic movement per ASTM C 719, to withstand the specified percentage change in the joint width existing at time of installation and remain in compliance with other requirements of ASTM C 920 for Uses indicated.
- D. VOC Content of Interior Sealants: Provide sealants and sealant primers for use inside the weatherproofing system that comply with the following limits for VOC content when calculated according to 40 CFR 59, Part 59, Subpart D (EPA Method 24):
 - 1. Architectural Sealants: 250 g/L.
 - 2. Sealant Primers for Nonporous Substrates: 250 g/L.
 - 3. Sealant Primers for Porous Substrates: 775 g/L.

- E. Stain-Test-Response Characteristics: Where sealants are specified to be nonstaining to porous substrates, provide products that have undergone testing according to ASTM C 1248 and have not stained porous joint substrates indicated for Project

2.2 LATEX JOINT SEALANT

- A. Acrylic-Emulsion Sealant: Manufacturer's standard, one part, nonsag, mildew-resistant, paintable latex acrylic-emulsion sealant complying with ASTM C 834, formulated to be paintable and recommended for exposed applications on interior locations involving joint movement of not more than plus or minus 5 percent.

- 1. Available Products: Subject to compliance with requirements, latex joint sealants that may be incorporated in the Work include, but are not limited to, the following:
 - a. AC-20; Pecora Corporation.
 - b. Tremflex 834; Tremco.
 - c. ALEX PLUS; DAP .

- B. Uses: General interior use, paintable.

2.3 MILDEW-RESISTANT SILICONE JOINT SEALANT

- A. Single-Component Mildew-Resistant Silicone Sealant: Manufacturer's standard, non-modified, one-part, silicone sealant; complying with ASTM C 920, Type S, Grade NS, Class 25, Uses NT, G, A, and, as applicable to non-porous joint substrates indicated, O. Formulate sealant with fungicide and specifically intended for sealing interior joints with nonporous substrates and subject to in-service exposure to conditions of high humidity and temperature extremes.

- 1. Available Products: Subject to compliance with requirements, silicone joint sealants that may be incorporated in the Work include, but are not limited to, the following:
 - a. 786 Mildew Resistant; Dow Corning.
 - b. Sanitary 1700; GE Silicones.
 - c. 898 Silicone Sanitary Sealant; Pecora Corporation.
 - d. Tremsil 600 White; Tremco.

- B. Uses: Interior use in wet locations, and all toilet and shower rooms.

2.4 NONSAG URETHANE JOINT SEALANT

- A. Multicomponent Nonsag Urethane Sealant: Manufacturer's standard, non-modified, multi-part, nonsag urethane sealant; complying with ASTM C 920, Type M, Grade NS, Class 25, Uses NT, M, G, A, and as applicable to joint substrates indicated, O.

- 1. Available Products: Subject to compliance with requirements, urethane joint sealants that may be incorporated in the Work include, but are not limited to, the following:
 - a. Dynatrol II, Pecora Corporation
 - b. Sikaflex-2c NS, Sika Corporation
 - c. Dymeric 240FC; Tremco.

- d. Masterseal NP 2; Master Builders Solutions Div., BASF

- B. Uses: Interior use for exposed concrete or masonry wall control joints

2.5 SILICONE JOINT SEALANT

- A. Single-Component, Nonsag, Neutral-Curing Silicone Joint Sealant: ASTM C 920, Type S, Grade NS, Class 100, for Use G, A, M, O; non-staining and field-tintable.

- 1. Basis of Design Product: Provide Pecora Corporation "890FTS" sealant or equal manufactured by one of the following:
 - a. Dow Corning Corporation.
 - b. GE Advanced Materials - Silicones
 - c. Sika Corporation, Construction Products Division
 - d. Tremco Incorporated

- B. Additional Movement Capability: 100 percent movement in extension and 50 percent in compression for a total of 150 percent movement.

- C. Uses: General exterior use.

2.6 POURABLE URETHANE JOINT SEALANT

- A. Multicomponent Pourable Urethane Sealant: Manufacturer's standard, non-modified, two-part, urethane sealant; complying with ASTM C 920, Type M, Grade P, Class 25, Uses T, M, A and, as applicable to joint substrates indicated, O.

- 1. Available Products: Subject to compliance with requirements, urethane joint sealants that may be incorporated in the Work include, but are not limited to, the following:
 - a. NR-200 Urexpam, Pecora Corporation
 - b. Sikaflex 2c SL, Sika Corporation
 - c. Masterseal SL 2; Master Builders Solutions Div., BASF

- B. Uses: Interior or exterior use for level pavement or slab joints.

2.7 NONSAG URETHANE JOINT SEALANT

- A. Multi-Part Non-Sag Urethane Sealant: Except as otherwise indicated, provide manufacturer's standard, non-modified, two-part, urethane sealant; complying with ASTM C 920, Type M, Grade NS, Class 25, Uses T, M, A and, as applicable to joint substrates indicated, O.

- 1. Available Products: Subject to compliance with requirements, urethane joint sealants that may be incorporated in the Work include, but are not limited to, the following:
 - a. Sikaflex 2c NS; Sika Corp
 - b. Dynatred, Pecora Corporation
 - c. Masterseal NP 2; Master Builders Solutions Div., BASF

- B. Uses: Interior or exterior use for pavement or slab joints where slope exceeds one percent.

2.8 ACOUSTICAL JOINT SEALANTS

- A. Acoustical Sealant: Non-sag (gun grade), non-flammable, latex-based sealant designed to limit sound transmission through interior STC-rated partitions. Sealant remains flexible and adhered to metal, wood, plaster, gypsum, and concrete after drying.
 - 1. Maintains the STC rating of partitions with intersections and penetrations sealed with product: Tested by independent, accredited, NVLAP facility according to ASTM E 90.
 - 2. Products: Provide one of the following:
 - a. QuietZone Acoustic Sealant by Owens Corning.
 - b. OSI GreenSeries SC-175 Draft & Acoustical Sound Sealant by Henkel Corporation
 - c. Pecora AIS-919: Acoustical and Insulation Latex Sealant by Pecora Corporation
 - d. Smoke 'N' Sound Acoustical Sealant by Specified Technologies Inc.
- B. Uses: At penetrations through and intersections of sound-rated wall, floor and ceiling assemblies in order to preserve their ability to reduce airborne sound impact noise transmission.

2.9 PREFORMED FOAM SEALANTS

- A. Preformed Foam Sealants: Manufacturer's standard preformed, precompressed, impregnated open-cell foam sealant manufactured from high-density urethane foam impregnated with a nondrying, water repellent agent; factory-produced in precompressed sizes and in roll or stick form to fit joint widths indicated and to develop a watertight and airtight seal when compressed to the degree specified by manufacturer; and complying with the following requirements:
 - 1. Properties: Permanently elastic, mildew-resistant, nonmigratory, nonstaining, and compatible with joint substrates and other joint sealants.
 - 2. Impregnating Agent: Chemically stabilized acrylic.
 - 3. Density: Manufacturer's standard.
 - 4. Backing: None.
 - 5. Available Products: Subject to compliance with requirements, preformed foam sealants that may be incorporated in the Work include, but are not limited to, the following:
 - a. "Emseal," Emseal Corp.
 - b. "Emseal Greyflex," Emseal Corp.
 - c. "Wil-Seal 150," Wil-Seal Construction Foams Div., Illbruck.
 - d. "Wil-Seal 250," Wil-Seal Construction Foams Div., Illbruck.

2.10 JOINT SEALANT BACKING

- A. General: Provide sealant backings of material and type that are nonstaining; are compatible with joint substrates, sealants, primers and other joint fillers; and are approved for applications indicated by sealant manufacturer based on field experience and laboratory testing.
- B. Plastic Foam Joint Fillers: Preformed, compressible, resilient, nonstaining, nonwaxing, nonextruding strips of flexible plastic foam of material indicated below and of size, shape, and density to control sealant depth and otherwise contribute to producing optimum sealant performance:
 - 1. Closed-cell polyethylene foam, nonabsorbent to liquid water and gas, nonoutgassing in unruptured state.
 - 2. Manufacturer: Provide Cera-Rod manufactured by W.R. Meadows, Inc., or equivalent.
- C. Bond-Breaker Tape: Polyethylene tape or other plastic tape as recommended by sealant manufacturer for preventing sealant from adhering to rigid, inflexible joint filler materials or joint surfaces at back of joint where such adhesion would result in sealant failure. Provide self-adhesive tape where applicable.

2.11 JOINT FILLERS FOR EXTERIOR CONCRETE SLABS

- A. General: Provide joint fillers of thickness and depth indicated, or if not indicated 1/2" thick by depth of joint.
- B. Bituminous Fiber Joint Filler: Provide preformed strips of with asphalt binder encased between two layers of saturated felt or glass-fiber felt, complying with ASTM D 1751.
 - 1. Protect top edge of joint filler during concrete placement with a metal, plastic, or other temporary preformed cap. Remove protective cap after concrete has been placed on both sides of joint and seal with sealant.

2.12 MISCELLANEOUS MATERIALS

- A. Primer: Material recommended by joint sealant manufacturer where required for adhesion of sealant to joint substrates indicated, as determined from preconstruction joint sealant-substrate tests and field tests.
- B. Cleaners for Nonporous Surfaces: Chemical cleaners acceptable to manufacturers of sealants and sealant backing materials, free of oily residues or other substances capable of staining or harming in any way joint substrates and adjacent nonporous surfaces, and formulated to promote optimum adhesion of sealants with joint substrates.
- C. Masking Tape: Nonstaining, nonabsorbent material compatible with joint sealants and surfaces adjacent to joints.

PART 3 - EXECUTION

3.1 EXAMINATION

- A. Examine joints indicated to receive joint sealants, with Installer present, for compliance with requirements for joint configuration, installation tolerances, and other conditions affecting joint sealant performance. Do not proceed with installation of joint sealants until unsatisfactory conditions have been corrected.

3.2 PREPARATION

- A. Surface Cleaning of Joints: Clean out joints immediately before installing joint sealants to comply with recommendations of joint sealant manufacturer and the following requirements:
 - 1. Remove all foreign material from joint substrates that could interfere with adhesion of joint sealant, including dust, paints (except for permanent, protective coatings tested and approved for sealant adhesion and compatibility by sealant manufacturer), old joint sealants, oil, grease, waterproofing, water repellents, water, surface dirt, and frost.
 - 2. Clean concrete, masonry, unglazed surfaces of ceramic tile, and similar porous joint substrate surfaces by brushing, grinding, blast cleaning, mechanical abrading, or a combination of these methods to produce a clean, sound substrate capable of developing optimum bond with joint sealants. Remove loose particles remaining from above cleaning operations by vacuuming or blowing out joints with oil-free compressed air.
 - 3. Remove laitance and form release agents from concrete.
 - 4. Clean metal, glass, porcelain enamel, glazed surfaces of ceramic tile, and other nonporous surfaces with chemical cleaners or other means that do not stain, harm substrates, or leave residues capable of interfering with adhesion of joint sealants.
- B. Joint Priming: Prime joint substrates where indicated or where recommended by joint sealant manufacturer based on preconstruction joint sealant-substrate tests or prior experience. Apply primer to comply with joint sealant manufacturer's recommendations. Confine primers to areas of joint sealant bond; do not allow spillage or migration onto adjoining surfaces.
- C. Masking Tape: Use masking tape where required to prevent contact of sealant with adjoining surfaces that otherwise would be permanently stained or damaged by such contact or by cleaning methods required to remove sealant smears. Remove tape immediately after tooling without disturbing joint seal.

3.3 INSTALLATION OF JOINT SEALANTS

- A. General: Comply with joint sealant manufacturer's printed installation instructions applicable to products and applications indicated, except where more stringent requirements apply.
- B. Sealant Installation Standard: Comply with recommendations of ASTM C 1193 for use of joint sealants as applicable to materials, applications, and conditions indicated.

- C. Installation of Sealant Backings: Install sealant backings to comply with the following requirements:
 - 1. Install joint fillers of type indicated to provide support of sealants during application and at position required to produce the cross-sectional shapes and depths of installed sealants relative to joint widths that allow optimum sealant movement capability.
 - a. Do not leave gaps between ends of joint fillers.
 - b. Do not stretch, twist, puncture, or tear joint fillers.
 - c. Remove absorbent joint fillers that have become wet prior to sealant application and replace with dry material.
 - 2. Install bond breaker tape between sealants where backer rods are not used between sealants and joint fillers or back of joints.
- D. Installation of Sealants: Install sealants by proven techniques that result in sealants directly contacting and fully wetting joint substrates, completely filling recesses provided for each joint configuration, and providing uniform, cross-sectional shapes and depths relative to joint widths that allow optimum sealant movement capability. Install sealants at the same time sealant backings are installed.
- E. Tooling of Nonsag Sealants: Immediately after sealant application and prior to time skinning or curing begins, tool sealants to form smooth, uniform beads of configuration indicated, to eliminate air pockets, and to ensure contact and adhesion of sealant with sides of joint. Remove excess sealants from surfaces adjacent to joint. Do not use tooling agents that discolor sealants or adjacent surfaces or are not approved by sealant manufacturer.
 - 1. Provide concave joint configuration per Figure 5A in ASTM C 1193, unless otherwise indicated.
 - a. Use masking tape to protect adjacent surfaces of recessed tooled joints.
- F. Installation of Preformed Foam Sealants: Install each length of sealant immediately after removing protective wrapping, taking care not to pull or stretch material, and to comply with sealant manufacturer's directions for installation methods, materials, and tools that produce seal continuity at ends, turns, and intersections of joints. For applications at low ambient temperatures where expansion of sealant requires acceleration to produce seal, apply heat to sealant in conformance with sealant manufacturer's recommendations.

3.4 CLEANING

- A. Clean off excess sealants or sealant smears adjacent to joints as work progresses by methods and with cleaning materials approved by manufacturers of joint sealants and of products in which joints occur.

3.5 PROTECTION

- A. Protect joint sealants during and after curing period from contact with contaminating substances or from damage resulting from construction operations or other causes so that

they are without deterioration or damage at time of Substantial Completion. If, despite such protection, damage or deterioration occurs, cut out and remove damaged or deteriorated joint sealants immediately so that and installations with repaired areas are indistinguishable from original work.

END OF SECTION 079200

SECTION 079500 - EXPANSION CONTROL

PART 1 - GENERAL

1.1 SUMMARY

- A. Types of joints for which architectural joint systems are specified include the following:
 - 1. Interior pedestrian traffic joints.
 - 2. Interior wall and ceiling joints.
 - 3. Exterior wall expansion joint.
- B. Related Sections include the following:
 - 1. Division 07 Section "Joint Sealants" for elastomeric sealants and preformed compressed-foam sealants without metal frames.
 - 2. Division 07 Sections "Sheet Metal Flashing and Trim" and "Roofing Accessories" for expansion joint covers at roof.

1.2 DEFINITIONS

- A. Architectural Joint System: Any filler or cover used to span, fill, cover, or seal a joint, except expanding foam seals and poured or foamed in-place sealants.
- B. Cyclic Movement: Periodic change between widest and narrowest joint widths in an automatically mechanically controlled system.
- C. Fire Barriers: Any material or material combination, when fire tested after cycling, designated to resist passage of flame and hot gases through a movement joint.
- D. Maximum Joint Width: Widest linear gap a joint system tolerates and performs its designed function without damaging its functional capabilities.
- E. Minimum Joint Width: Narrowest linear gap a joint system tolerates and performs its designed function without damaging its functional capabilities.
- F. Movement Capability: Value obtained from the difference between widest and narrowest widths of a joint opening typically expressed in numerical values (mm or inches) or a percentage of nominal value of joint width.
- G. Nominal Joint Width: Width of linear gap indicated as representing the conditions existing when architectural joint systems will be installed or, if no nominal joint width is indicated, a width equal to the sum of maximum and minimum joint widths divided by two.

1.3 PERFORMANCE REQUIREMENTS

- A. General: Provide factory-fabricated architectural joint systems capable of withstanding the types of loads and of accommodating the kinds of movement, and the other functions for which they are designed including those specified below, without failure. Types of failure include those listed in Appendix X3 of ASTM E 1399.
 - 1. Pedestrian Traffic Joints: Support pedestrian traffic across joint.
 - 2. Exterior Joints: Maintain continuity of weather enclosure.
 - 3. Joints in Fire-Resistance-Rated Assemblies: Maintain fire-resistance ratings of assemblies.
 - 4. Joints in Smoke Barriers: Maintain integrity of smoke barrier.
 - 5. Other Joints: Where indicated, provide joint systems that prevent penetration of water, moisture, and other substances deleterious to building components or content.
 - 6. Joints in Surfaces with Architectural Finishes: Serve as finished architectural joint closures.

1.4 SUBMITTALS

- A. Product Data: Include manufacturer's product specifications, construction details, material and finish descriptions, and dimensions of individual components and seals.
- B. Shop Drawings: For each joint system specified, provide the following:
 - 1. Placement Drawings: Include line diagrams showing entire route of each joint system, plans, elevations, sections, details, joints, splices, locations of joints and splices, and attachments to other Work. Where joint systems change planes, provide Isometric Drawings depicting how components interconnect to achieve continuity of joint covers and fillers.
- C. Samples for Initial Selection: Manufacturer's color charts consisting of units or sections of units showing the full range of colors, textures, and patterns available for each exposed metal and elastomeric material of joint system indicated.
 - 1. Include similar Samples of material for joints and accessories involving color selection.
- D. Samples for Verification: Full-size units 6 inches (150 mm) long of each type of joint system indicated; in sets for each finish, color, texture, and pattern specified, showing the full range of variations expected in these characteristics.
- E. Product Test Reports: From a qualified testing agency indicating architectural joint systems comply with requirements, based on comprehensive testing of current products.
- F. Research/Evaluation Reports: Evidence of architectural joint system's compliance with building code in effect for Project, from a model code organization acceptable to authorities having jurisdiction.

1.5 QUALITY ASSURANCE

- A. Source Limitations: Obtain architectural joint systems through one source from a single manufacturer. Coordinate compatibility with adjoining joint systems specified in other Sections.
- B. Product Options: Drawings indicate size, profiles, and dimensional requirements of architectural joint systems and are based on the specific systems indicated. Other manufacturers' systems complying with requirements may be considered. Refer to Division 01 Section "Product Requirements."
 - 1. Do not modify intended aesthetic effects, as judged solely by Architect, except with Architect's approval. If modifications are proposed, submit comprehensive explanatory data to Architect for review.

PART 2 - PRODUCTS

2.1 MANUFACTURERS

- A. Basis-of-Design Products: The design for each architectural joint system specified in Part 2 "Architectural Joint Systems" Article below is based on the products named. Subject to compliance with requirements, provide either the named products or comparable products by one of the following:
 - 1. M M Systems
 - 2. Balco, Inc.
 - 3. Construction Specialties, Inc.
 - 4. Inpro
 - 5. Watson Bowman Acme.

2.2 MATERIALS

- A. Aluminum: ASTM B 221 (ASTM B 221M), alloy 6063-T5 for extrusions; ASTM B 209 (ASTM B 209M), alloy 6061-T6 for sheet and plate.
 - 1. Apply manufacturer's standard protective coating on aluminum surfaces to be placed in contact with cementitious materials.
- B. Preformed Seals: Single or multicellular extruded elastomeric seals designed with or without continuous, longitudinal, internal baffles. Formed to be installed in frames or with anchored flanges, in color indicated or, if not indicated, as selected by Architect from manufacturer's standard colors.
- C. Strip Seals: Elastomeric membrane or tubular extrusions with a continuous longitudinal internal baffle system throughout complying with ASTM E 1783; used with compatible frames, flanges, and molded-rubber anchor blocks.
- D. Compression Seals: Preformed, elastomeric extrusions having internal baffle system complying with ASTM E 1612 in sizes and profiles indicated or as recommended by manufacturer.

- E. Fire Barrier: Manufacturer's standard for fire ratings indicated on Drawings.
- F. Accessories: Manufacturer's standard anchors, clips, fasteners, set screws, spacers, flexible moisture barrier and filler materials, drain tubes, lubricants, adhesives, and other accessories compatible with material in contact, as indicated or required for complete installations.

2.3 ARCHITECTURAL JOINT SYSTEMS

- A. General: Provide joint systems of design, basic profile, materials, and operation indicated. Provide units with the capability to accommodate joint widths indicated and variations in adjacent surfaces.
 - 1. Furnish units in longest practicable lengths to minimize number of end joints. Provide hairline mitered corners where joint changes directions or abuts other materials.
 - 2. Include closure materials and transition pieces, tee-joints, corners, curbs, cross-connections, and other accessories as required to provide continuous joint systems.
 - 3. Frames for Strip Seals: Designed with semiclosed cavity that provides a mechanical lock for seals of type indicated.
 - 4. Fire Barrier: Provide manufacturer's standard fire barriers material where indicated on the Drawings, for fire ratings indicated.
- B. Interior Floor-to-Floor Architectural Joint System: Metal frame and free-floating center plate for interior, pedestrian traffic joints. Units shall have recessed side frames for minimal visual impact.
 - 1. Basis-of-Design Product: Model ALR-200 by Construction Specialties or equal.
 - 2. Nominal Joint Width: 2 inches.
 - 3. Frame and Plate Material: Aluminum extrusions, mill finish.
- C. Interior Wall-to-Wall and Ceiling-to-Ceiling Architectural Joint System: Metal frame and elastomeric seal for interior wall and ceiling joints. Units shall be designed for minimal visual impact.
 - 1. Basis-of-Design Product: Products by Construction Specialties as follows:
 - a. For Acoustical Ceiling Locations: C/S Model FCF-200, or equal.
 - b. For Gypsum Board Walls and Ceilings: C/S Model FWF-200, or equal.
 - 2. Nominal Joint Width: 2 inches.
 - 3. Color of Elastomeric Seal: As selected by Architect.
 - 4. Frame Material: Aluminum extrusions, mill finish.
- D. Exterior Expansion Joint / Waterproofing Joint System: Exposed elastomeric bellows type seal with concealed secondary elastomeric seal and aluminum retainer frame for exterior vertical joints in exterior walls.

1. Basis-of-Design Product: C/S Model SF-200 by Construction Specialties, or equal.
2. Nominal Joint Width: 2 inches.
3. Color of Exposed Elastomeric Material: As selected by Architect to match adjacent wall color.

2.4 FINISHES, GENERAL

- A. Comply with NAAMM's "Metal Finishes Manual for Architectural and Metal Products" for recommendations for applying and designating finishes.
- B. Protect mechanical finishes on exposed surfaces from damage by applying a strippable, temporary protective covering before shipping.

2.5 ALUMINUM FINISHES

- A. Finish designations prefixed by AA comply with the system established by the Aluminum Association for designating aluminum finishes.
- B. As-Fabricated Finish: AA-M10 (Mechanical Finish: as fabricated, unspecified).

PART 3 - EXECUTION

3.1 PREPARATION

- A. Prepare substrates according to architectural joint system manufacturer's written instructions.
- B. Coordinate and furnish anchorages, Placement Drawings, and instructions for installing joint systems to be embedded in or anchored to concrete or to have recesses formed into edges of concrete slab for later placement and grouting-in of frames.
- C. Fastening to In-Place Construction: Provide anchorage devices and fasteners where necessary to secure joint systems to in-place construction, including threaded fasteners with drilled-in expansion shields for masonry and concrete where anchoring members are not embedded in concrete. Provide fasteners of metal, type, and size to suit type of construction indicated and to provide for secure attachment of joint systems.

3.2 INSTALLATION

- A. Comply with manufacturer's written instructions for handling and installing architectural joint assemblies and materials, unless more stringent requirements are indicated.
- B. Coordinate installation of architectural joint assembly materials and associated work so complete assemblies comply with assembly performance requirements.
- C. Terminate exposed ends of exterior architectural joint assemblies with factory-fabricated termination devices to maintain waterproof system.

- D. Install factory-fabricated transitions between building expansion-joint cover assemblies and roof expansion-joint assemblies to provide continuous, uninterrupted, watertight construction.
- E. Cutting, Fitting, and Placement: Perform cutting, drilling, and fitting required to install joint systems.
 - 1. Install joint cover assemblies in true alignment and proper relationship to joints and adjoining finished surfaces measured from established lines and levels.
 - 2. Allow adequate free movement for thermal expansion and contraction of metal to avoid buckling.
 - 3. Set covers in horizontal surfaces at elevations that place exposed surfaces flush with adjoining finishes.
 - 4. Locate wall, ceiling, and soffit covers in continuous contact with adjacent surfaces.
 - 5. Securely attach in place with required accessories.
 - 6. Locate anchors at interval recommended by manufacturer, but not less than 3 inches (75 mm) from each end and not more than 24 inches (600 mm) o.c.
- F. Continuity: Maintain continuity of joint systems with a minimum number of end joints and align metal members. Cut and fit ends to produce joints that will accommodate thermal expansion and contraction of metal to avoid buckling of frames. Adhere flexible filler materials, if any, to frames with adhesive or pressure-sensitive tape as recommended by manufacturer.
- G. Joint Systems with Seals: Seal end joints within continuous runs and joints at transitions according to manufacturer's written instructions to provide a watertight installation.

3.3 CLEANING AND PROTECTION

- A. Do not remove protective covering until finish work in adjacent areas is complete. When protective covering is removed, clean exposed metal surfaces to comply with manufacturer's written instructions.

END OF SECTION 079500

SECTION 081113 - HOLLOW METAL DOORS AND FRAMES

PART 1 - GENERAL

1.1 SUMMARY

A. Section includes the following hollow-metal work:

1. Steel doors
2. Steel door frames
3. Fire-rated door and frame assemblies
4. Transom frames, borrowed lite frames and sidelite frames.
5. Fire-rated frames

B. Related Requirements:

1. Section 087100 "Door Hardware" for door hardware for hollow-metal doors.
2. Section 088000 "Glazing" for glazing inserted in hollow metal doors and frames.

1.2 DEFINITIONS

A. Minimum Thickness: Minimum thickness of base metal without coatings according to SDI A250.8.

1.3 COORDINATION

A. Coordinate anchorage installation for hollow-metal frames. Furnish setting drawings, templates, and directions for installing anchorages, including sleeves, concrete inserts, anchor bolts, and items with integral anchors. Deliver such items to Project site in time for installation.

1.4 PREINSTALLATION MEETINGS

A. Preinstallation Conference: Conduct conference at Project site.

1.5 ACTION SUBMITTALS

A. Product Data: For each type of product. Include construction details, material descriptions, core descriptions, fire-resistance ratings, and finishes.

B. Shop Drawings: Include the following:

1. Elevations of each door type.
2. Details of doors, including vertical- and horizontal-edge details and metal thicknesses.
3. Frame details for each frame type, including dimensioned profiles and metal thicknesses.
4. Locations of reinforcement and preparations for hardware.

5. Details of each different wall opening condition.
 6. Details of anchorages, joints, field splices, and connections.
 7. Details of accessories.
 8. Details of moldings, removable stops, and glazing.
 9. Details of conduit and preparations for power, signal, and control systems.
- C. Schedule: Provide a schedule of hollow-metal work prepared by or under the supervision of supplier, using same reference numbers for details and openings as those on Drawings. Coordinate with final Door Hardware Schedule.

1.6 INFORMATIONAL SUBMITTALS

- A. Product Test Reports: For each type of hollow-metal door and frame assembly, for tests performed by a qualified testing agency.
- B. Oversize Construction Certification: For assemblies required to be fire rated and exceeding limitations of labeled assemblies.

1.7 DELIVERY, STORAGE, AND HANDLING

- A. Deliver hollow-metal work palletized, packaged, or crated to provide protection during transit and Project-site storage. Do not use nonvented plastic.
 1. Provide additional protection to prevent damage to factory-finished units.
- B. Deliver welded frames with two removable spreader bars across bottom of frames, tack welded to jambs and mullions.
- C. Store hollow-metal work vertically under cover at Project site with head up. Place on minimum 4-inch- (102-mm-) high wood blocking. Provide minimum 1/4-inch (6-mm) space between each stacked door to permit air circulation.

PART 2 - PRODUCTS

2.1 MANUFACTURERS

- A. Manufacturers: Subject to compliance with requirements, available manufacturers offering products that may be incorporated into the Work include, but are not limited to, the following:
 1. Ceco Door Products; an Assa Abloy Group company.
 2. Curries Company; an Assa Abloy Group company.
 3. Republic Doors and Frames.
- B. Source Limitations: Obtain hollow-metal work from single source from single manufacturer.

2.2 REGULATORY REQUIREMENTS

- A. Fire-Rated Assemblies: Complying with NFPA 80 and listed and labeled by a qualified testing agency acceptable to authorities having jurisdiction for fire-protection ratings indicated, based on testing at positive pressure according to NFPA 252 or UL 10C.
 - 1. Smoke- and Draft-Control Assemblies: Provide an assembly with gaskets listed and labeled for smoke and draft control by a qualified testing agency acceptable to authorities having jurisdiction, based on testing according to UL 1784 and installed in compliance with NFPA 105.

2.3 INTERIOR DOORS AND FRAMES

- A. Construct interior doors and frames to comply with the standards indicated for materials, fabrication, hardware locations, hardware reinforcement, tolerances, and clearances, and as specified.
- B. Extra-Heavy-Duty Doors and Frames: SDI A250.8, Level 3. Provide for interior door and frame locations.
 - 1. Physical Performance: Level A according to SDI A250.4.
 - 2. Doors:
 - a. Type: As indicated in the Door and Frame Schedule.
 - b. Thickness: 1-3/4 inches (44.5 mm).
 - c. Face: Uncoated, cold-rolled steel sheet, minimum thickness of 16 gage 0.053 inch (1.3 mm), except as noted below.
 - 1) Metallic-coated, with minimum A40 (ZF120) coating at the following locations: Basement doors.
 - d. Edge Construction: Model 1, Full Flush
 - a. Core: Manufacturer's standard kraft-paper honeycomb, polystyrene, polyurethane, polyisocyanurate, mineral-board, or vertical steel-stiffener core at manufacturer's discretion.
 - 1) Provide mineral core for fire rated doors
 - 3. Frames:
 - a. Materials: Minimum thickness of 16 gage, 0.053 inch (1.3 mm), uncoated, steel sheet for the following locations:
 - 1) Wood doors, unless otherwise indicated.
 - b. Materials: Minimum thickness of 14 gage, 0.067 inch (1.7 mm), uncoated, steel sheet (except provide metallic coated where door is metallic coated) for the following locations:
 - 1) Level 3 steel doors
 - 2) Wood doors at all leafs wider than 36-inches (914-mm), and all electrical rooms, storage rooms, machine rooms, mechanical rooms, and maintenance areas
 - c. Construction: Full profile welded.

4. Exposed Finish: Prime door and frames.

2.4 FRAME ANCHORS

A. Jamb Anchors:

1. Masonry Type: Adjustable strap-and-stirrup or T-shaped anchors to suit frame size, not less than 0.042 inch (1.0 mm) thick, with corrugated or perforated straps not less than 2 inches (51 mm) wide by 10 inches (254 mm) long; or wire anchors not less than 0.177 inch (4.5 mm) thick.
2. Stud-Wall Type: Designed to engage stud, welded to back of frames; not less than 0.042 inch (1.0 mm) thick.
3. Postinstalled Expansion Type for In-Place Concrete or Masonry: Minimum 3/8-inch- (9.5-mm-) diameter bolts with expansion shields or inserts. Provide pipe spacer from frame to wall, with throat reinforcement plate, welded to frame at each anchor location.

B. Floor Anchors: Formed from same material as frames, minimum thickness of 0.042 inch (1.0 mm), and as follows:

1. Monolithic Concrete Slabs: Clip-type anchors, with two holes to receive fasteners.
2. Separate Topping Concrete Slabs: Adjustable-type anchors with extension clips, allowing not less than 2-inch (51-mm) height adjustment. Terminate bottom of frames at finish floor surface.

2.5 MATERIALS

- A. Cold-Rolled Steel Sheet: ASTM A 1008/A 1008M, Commercial Steel (CS), Type B; suitable for exposed applications.
- B. Hot-Rolled Steel Sheet: ASTM A 1011/A 1011M, Commercial Steel (CS), Type B; free of scale, pitting, or surface defects; pickled and oiled.
- C. Metallic-Coated Steel Sheet: ASTM A 653/A 653M, Commercial Steel (CS), Type B.
- D. Frame Anchors: ASTM A 879/A 879M, Commercial Steel (CS), 04Z (12G) coating designation; mill phosphatized.
 1. For anchors built into exterior walls, steel sheet complying with ASTM A 1008/A 1008M or ASTM A 1011/A 1011M, hot-dip galvanized according to ASTM A 153/A 153M, Class B.
- E. Inserts, Bolts, and Fasteners: Hot-dip galvanized according to ASTM A 153/A 153M.
- F. Power-Actuated Fasteners in Concrete: Fastener system of type suitable for application indicated, fabricated from corrosion-resistant materials, with clips or other accessory devices for attaching hollow-metal frames of type indicated.

- G. Grout: ASTM C 476, except with a maximum slump of 4 inches (102 mm), as measured according to ASTM C 143/C 143M.
- H. Mineral-Fiber Insulation: ASTM C 665, Type I (blankets without membrane facing); consisting of fibers manufactured from slag or rock wool; with maximum flame-spread and smoke-developed indexes of 25 and 50, respectively; passing ASTM E 136 for combustion characteristics.
- I. Glazing: Comply with requirements in Section 088000 "Glazing."
- J. Bituminous Coating: Cold-applied asphalt mastic, compounded for 15-mil (0.4-mm) dry film thickness per coat. Provide inert-type noncorrosive compound free of asbestos fibers, sulfur components, and other deleterious impurities.

2.6 FABRICATION

- A. Fabricate hollow-metal work to be rigid and free of defects, warp, or buckle. Accurately form metal to required sizes and profiles, with minimum radius for metal thickness. Where practical, fit and assemble units in manufacturer's plant. To ensure proper assembly at Project site, clearly identify work that cannot be permanently factory assembled before shipment.
- B. Hollow-Metal Doors:
 - 1. Steel-Stiffened Door Cores: Provide minimum thickness 0.026 inch (0.66 mm), steel vertical stiffeners of same material as face sheets extending full-door height, with vertical webs spaced not more than 6 inches (152 mm) apart. Spot weld to face sheets no more than 5 inches (127 mm) o.c. Fill spaces between stiffeners with glass- or mineral-fiber insulation.
 - 2. Fire Door Cores: As required to provide fire-protection ratings indicated.
 - 3. Vertical Edges for Single-Acting Doors: Bevel edges 1/8 inch in 2 inches (3.2 mm in 51 mm).
 - 4. Top Edge Closures: Close top edges of doors with flush closures of same material as face sheets.
 - 5. Bottom Edge Closures: Close bottom edges of doors where required for attachment of weather stripping with end closures or channels of same material as face sheets.
 - 6. Astragals: Provide overlapping astragal on one leaf of pairs of doors where required by NFPA 80 for fire-performance rating or where indicated. Extend minimum 3/4 inch (19 mm) beyond edge of door on which astragal is mounted or as required to comply with published listing of qualified testing agency.
- C. Hollow-Metal Frames: Where frames are fabricated in sections due to shipping or handling limitations, provide alignment plates or angles at each joint, fabricated of same thickness metal as frames.
 - 1. Sidelight and Transom Bar Frames: Provide closed tubular members with no visible face seams or joints, fabricated from same material as door frame. Fasten members at crossings and to jambs by butt welding.

2. Provide countersunk, flat- or oval-head exposed screws and bolts for exposed fasteners unless otherwise indicated.
 3. Grout Guards: Weld guards to frame at back of hardware mortises in frames to be grouted.
 4. Floor Anchors: Weld anchors to bottoms of jambs with at least four spot welds per anchor; however, for slip-on drywall frames, provide anchor clips or countersunk holes at bottoms of jambs.
 5. Jamb Anchors: Provide number and spacing of anchors as follows:
 - a. Masonry Type: Locate anchors not more than 16 inches (406 mm) from top and bottom of frame. Space anchors not more than 32 inches (813 mm) o.c., to match coursing, and as follows:
 - 1) Two anchors per jamb up to 60 inches (1524 mm) high.
 - 2) Three anchors per jamb from 60 to 90 inches (1524 to 2286 mm) high.
 - 3) Four anchors per jamb from 90 to 120 inches (2286 to 3048 mm) high.
 - 4) Four anchors per jamb plus one additional anchor per jamb for each 24 inches (610 mm) or fraction thereof above 120 inches (3048 mm) high.
 - b. Stud-Wall Type: Locate anchors not more than 18 inches (457 mm) from top and bottom of frame. Space anchors not more than 32 inches (813 mm) o.c. and as follows:
 - 1) Three anchors per jamb up to 60 inches (1524 mm) high.
 - 2) Four anchors per jamb from 60 to 90 inches (1524 to 2286 mm) high.
 - 3) Five anchors per jamb from 90 to 96 inches (2286 to 2438 mm) high.
 - 4) Five anchors per jamb plus one additional anchor per jamb for each 24 inches (610 mm) or fraction thereof above 96 inches (2438 mm) high.
 - c. Postinstalled Expansion Type: Locate anchors not more than 6 inches (152 mm) from top and bottom of frame. Space anchors not more than 26 inches (660 mm) o.c.
 6. Head Anchors: Two anchors per head for frames more than 42 inches (1067 mm) wide and mounted in metal-stud partitions.
 7. Door Silencers: Except on weather-stripped frames, drill stops to receive door silencers as follows. Keep holes clear during construction.
 - a. Single-Door Frames: Drill stop in strike jamb to receive three door silencers.
 - b. Double-Door Frames: Drill stop in head jamb to receive two door silencers.
- D. Fabricate concealed stiffeners and edge channels from either cold- or hot-rolled steel sheet.

- E. Hardware Preparation: Factory prepare hollow-metal work to receive templated mortised hardware; include cutouts, reinforcement, mortising, drilling, and tapping according to SDI A250.6, the Door Hardware Schedule, and templates.
 - 1. Reinforce doors and frames to receive nontemplated, mortised, and surface-mounted door hardware.
 - 2. Comply with applicable requirements in SDI A250.6 and BHMA A156.115 for preparation of hollow-metal work for hardware.
- F. Stops and Moldings: Provide stops and moldings around glazed lites and louvers where indicated. Form corners of stops and moldings with butted or mitered hairline joints.
 - 1. Single Glazed Lites: Provide fixed stops and moldings welded on secure side of hollow-metal work.
 - 2. Multiple Glazed Lites: Provide fixed and removable stops and moldings so that each glazed lite is capable of being removed independently.
 - 3. Provide fixed frame moldings on outside of exterior and on secure side of interior doors and frames.
 - 4. Provide loose stops and moldings on inside of hollow-metal work.
 - 5. Coordinate rabbet width between fixed and removable stops with glazing and installation types indicated.
 - 6. Where Pyrostop glazing is scheduled to be inserted into openings in hollow metal doors provide door manufacturer's special window kit to accommodate thickness of glazing unit; Type 8 window kit by Curries, or equal.

2.7 STEEL FINISHES

- A. Prime Finish: Clean, pretreat, and apply manufacturer's standard primer.
 - 1. Shop Primer: Manufacturer's standard, fast-curing, lead- and chromate-free primer complying with SDI A250.10; recommended by primer manufacturer for substrate; compatible with substrate and field-applied coatings despite prolonged exposure.

2.8 ACCESSORIES

- A. Mullions and Transom Bars: Join to adjacent members by welding or rigid mechanical anchors.
- B. Grout Guards: Formed from same material as frames, not less than 0.016 inch (0.4 mm) thick.

PART 3 - EXECUTION

3.1 EXAMINATION

- A. Examine substrates, areas, and conditions, with Installer present, for compliance with requirements for installation tolerances and other conditions affecting performance of the Work.
- B. Examine roughing-in for embedded and built-in anchors, and for electrical wiring as required, to verify actual locations before frame installation.
- C. Prepare written report, endorsed by Installer, listing conditions detrimental to performance of the Work.
- D. Proceed with installation only after unsatisfactory conditions have been corrected.

3.2 PREPARATION

- A. Remove welded-in shipping spreaders installed at factory. Restore exposed finish by grinding, filling, and dressing, as required to make repaired area smooth, flush, and invisible on exposed faces.
- B. Drill and tap doors and frames to receive nontemplated, mortised, and surface-mounted door hardware.

3.3 INSTALLATION

- A. General: Install hollow-metal work plumb, rigid, properly aligned, and securely fastened in place. Comply with Drawings and manufacturer's written instructions.
- B. Hollow-Metal Frames: Install hollow-metal frames of size and profile indicated. Comply with SDI A250.11 as required by standards specified.
 - 1. Set frames accurately in position; plumbed, aligned, and braced securely until permanent anchors are set. After wall construction is complete, remove temporary braces, leaving surfaces smooth and undamaged.
 - a. At fire-rated openings, install frames according to NFPA 80.
 - b. Where frames are fabricated in sections because of shipping or handling limitations, field splice at approved locations by welding face joint continuously; grind, fill, dress, and make splice smooth, flush, and invisible on exposed faces.
 - c. Install frames with removable stops located on secure side of opening.
 - d. Install door silencers in frames before grouting.
 - e. Remove temporary braces necessary for installation only after frames have been properly set and secured.
 - f. Check plumb, square, and twist of frames as walls are constructed. Shim as necessary to comply with installation tolerances.
 - g. Field apply bituminous coating to backs of frames that will be filled with grout containing antifreezing agents.
 - 2. Floor Anchors: Provide floor anchors for each jamb and mullion that extends to floor, and secure with postinstalled expansion anchors.

- a. Floor anchors may be set with power-actuated fasteners instead of postinstalled expansion anchors if so indicated and approved on Shop Drawings.
 3. Metal-Stud Partitions: Solidly pack mineral-fiber insulation inside frames.
 4. Masonry Walls: Coordinate installation of frames to allow for solidly filling space between frames and masonry with grout.
 5. Concrete Walls: Solidly fill space between frames and concrete with mineral-fiber insulation.
 6. In-Place Concrete or Masonry Construction: Secure frames in place with postinstalled expansion anchors. Countersink anchors, and fill and make smooth, flush, and invisible on exposed faces.
 7. Installation Tolerances: Adjust hollow-metal door frames for squareness, alignment, twist, and plumb to the following tolerances:
 - a. Squareness: Plus or minus 1/16 inch (1.6 mm), measured at door rabbet on a line 90 degrees from jamb perpendicular to frame head.
 - b. Alignment: Plus or minus 1/16 inch (1.6 mm), measured at jambs on a horizontal line parallel to plane of wall.
 - c. Twist: Plus or minus 1/16 inch (1.6 mm), measured at opposite face corners of jambs on parallel lines, and perpendicular to plane of wall.
 - d. Plumbness: Plus or minus 1/16 inch (1.6 mm), measured at jambs at floor.
- C. Hollow-Metal Doors: Fit hollow-metal doors accurately in frames, within clearances specified below. Shim as necessary.
1. Non-Fire-Rated Steel Doors:
 - a. Between Door and Frame Jambs and Head: 1/8 inch (3.2 mm) plus or minus 1/32 inch (0.8 mm).
 - b. Between Edges of Pairs of Doors: 1/8 inch (3.2 mm) to 1/4 inch (6.3 mm) plus or minus 1/32 inch (0.8 mm).
 - c. At Bottom of Door: 3/4 inch (19.1 mm) plus or minus 1/32 inch (0.8 mm).
 - d. Between Door Face and Stop: 1/16 inch (1.6 mm) to 1/8 inch (3.2 mm) plus or minus 1/32 inch (0.8 mm).
 2. Fire-Rated Doors: Install doors with clearances according to NFPA 80.
 3. Smoke-Control Doors: Install doors and gaskets according to NFPA 105.
- D. Glazing: Comply with installation requirements in Section 088000 "Glazing" and with hollow-metal manufacturer's written instructions.
1. Secure stops with countersunk flat- or oval-head machine screws spaced uniformly not more than 9 inches (230 mm) o.c. and not more than 2 inches (51 mm) o.c. from each corner.

3.4 ADJUSTING AND CLEANING

- A. Final Adjustments: Check and readjust operating hardware items immediately before final inspection. Leave work in complete and proper operating condition. Remove and

replace defective work, including hollow-metal work that is warped, bowed, or otherwise unacceptable.

- B. Remove grout and other bonding material from hollow-metal work immediately after installation.
- C. Prime-Coat Touchup: Immediately after erection, sand smooth rusted or damaged areas of prime coat and apply touchup of compatible air-drying, rust-inhibitive primer.

END OF SECTION 081113

SECTION 081416 - FLUSH WOOD DOORS

PART 1 - GENERAL

1.1 SUMMARY

- A. Section Includes:
 - 1. Solid-core doors with wood-veneer faces for transparent finish.
 - 2. High STC solid-core doors with wood-veneer faces for transparent finish.
 - 3. Aluminum-framed, top-hung sliding wood sound control door assemblies.
 - 4. Factory finishing flush wood doors.
 - 5. Factory fitting flush wood doors to frames and factory machining for hardware.

- B. Related Requirements:
 - 1. Division 08 Section "Hollow Metal Doors and Frames" for steel door frames.
 - 2. Division 08 Section "Glazing" for glass view panels in flush wood doors

1.2 PREINSTALLATION MEETINGS

- A. Preinstallation Conference: Conduct conference at Project site.

1.3 ACTION SUBMITTALS

- A. Product Data: For each type of door. Include details of core and edge construction, louvers, and trim for openings. Include factory-finishing specifications. For acoustical doors, include test report for acoustical performance.

- B. Shop Drawings: Indicate location, size, and hand of each door; elevation of each kind of door; construction details not covered in Product Data; and the following:
 - 1. Dimensions and locations of blocking.
 - 2. Dimensions and locations of mortises and holes for hardware.
 - 3. Dimensions and locations of cutouts.
 - 4. Undercuts.
 - 5. Requirements for veneer matching.
 - 6. Doors to be factory finished and finish requirements.
 - 7. Fire-protection ratings for fire-rated doors.
 - 8. Provide schedule of doors based on door schedule included in contract documents
 - 9. For sliding door assemblies, frame anchorages and wall reinforcement requirements.

- C. Samples for Initial Selection: For factory-finished doors.

- D. Samples for Verification:
 - 1. Factory finishes applied to actual door face materials, approximately 8 by 10 inches (200 by 250 mm), for each material and finish. For each wood species

and transparent finish, provide set of three Samples showing typical range of color and grain to be expected in finished Work.

2. Frames for light openings, 6 inches (150 mm) long, for each material, type, and finish required.
3. Corner sections of doors, approximately 8 by 10 inches (200 by 250 mm), with door faces and edges representing actual materials to be used.
 - a. Provide Samples for each species of veneer and solid lumber required.
 - b. Finish veneer-faced door Samples with same materials proposed for factory-finished doors.

1.4 INFORMATIONAL SUBMITTALS

A. Qualification Data: For door inspector.

1. Fire-Rated Door Inspector: Submit documentation of compliance with NFPA 80, Section 5.2.3.1
2. Egress Door Inspector: Submit documentation of compliance with NFPA 101, Section 7.2.1.15.4

B. Sample Warranty: For special warranty.

C. Quality Standard Compliance Certificates: AWI Quality Certification Program certificates.

D. Field quality control reports.

1.5 QUALITY ASSURANCE

A. Fire-Rated Door Inspector Qualifications: Inspector for field quality-control inspections of fire-rated door assemblies complies with qualifications set forth in NFPA 80, Section 5.2.3.1

B. Egress Door Inspector Qualifications: Inspector for field quality-control inspections of egress door assemblies complies with qualifications set forth in NFPA 101, Section 7.2.1.15.4

1.6 DELIVERY, STORAGE, AND HANDLING

A. Comply with requirements of referenced standard and manufacturer's written instructions.

B. Package doors individually in plastic bags or cardboard cartons.

C. Mark each door on top and bottom rail with opening number used on Shop Drawings.

1.7 FIELD CONDITIONS

A. Environmental Limitations: Do not deliver or install doors until spaces are enclosed and weathertight, wet work in spaces is complete and dry, and HVAC system is operating and maintaining temperature between 60 and 90 deg F (16 and 32 deg C) and relative humidity between 25 and 55 percent during remainder of construction period.

1.8 WARRANTY

- A. Special Warranty: Manufacturer agrees to repair or replace doors that fail in materials or workmanship within specified warranty period.
 - 1. Failures include, but are not limited to, the following:
 - a. Warping (bow, cup, or twist) more than 1/4 inch (6.4 mm) in a 42-by-84-inch (1067-by-2134-mm) section.
 - b. Telegraphing of core construction in face veneers exceeding 0.01 inch in a 3-inch (0.25 mm in a 76.2-mm) span.
 - 2. Warranty shall also include installation and finishing that may be required due to repair or replacement of defective doors.
 - 3. Warranty Period for Solid-Core Interior Doors: Life of installation.
- B. Contractor's Responsibilities: Replace doors where Contractor's work contributed to rejection or to voiding of manufacturer's warranty

PART 2 - PRODUCTS

2.1 MANUFACTURERS

- A. Manufacturers: Subject to compliance with requirements, available manufacturers offering products that may be incorporated into the Work include, but are not limited to, the following:
 - 1. Marshfield – Algoma by Masonite Architectural
 - 2. Oshkosh Door Company.
 - 3. VT Industries, Inc. (formerly Eggers)
- B. Source Limitations:
 - 1. Obtain flush wood doors from single manufacturer.
 - 2. Obtain each of the top-hung, sliding door components from one source with the complete integrated assembly from a single manufacturer.

2.2 FLUSH WOOD DOORS, GENERAL

- A. Quality Standard: In addition to requirements specified, comply with AWI's, AWMAC's, and WI's "Architectural Woodwork Standards."
 - 1. Provide AWI Quality Certification Labels indicating that doors comply with requirements of grades specified.
 - 2. Contract Documents contain selections chosen from options in quality standard and additional requirements beyond those of quality standard. Comply with those selections and requirements in addition to quality standard.
- B. Low-Emitting Materials: Fabricate doors with adhesives and composite wood products that do not contain urea formaldehyde.
- C. Fire-Rated Wood Doors: Doors complying with NFPA 80 that are listed and labeled by a qualified testing agency, for fire-protection ratings indicated, based on testing at positive pressure according to NFPA 252 or UL 10C. After 5 minutes into the NFPA

252 test, the neutral pressure level in the furnace shall be established at 40 inches (1016 mm) or less above the sill. Provide "Category A" Positive Pressure Tested doors for all fire-rated wood doors.

1. Oversize Fire-Rated Door Assemblies: For units exceeding sizes of tested assemblies, provide certification by a qualified testing agency that doors comply with standard construction requirements for tested and labeled fire-rated door assemblies except for size.
 2. Cores: Provide core specified or mineral core as needed to provide fire-protection rating indicated.
 3. Edge Construction: Provide edge construction with intumescent seals concealed by outer stile; UL category A. Comply with specified requirements for exposed edges.
 4. Pairs: Provide fire-retardant stiles that are listed and labeled for applications indicated without formed-steel edges and astragals. Provide stiles with concealed intumescent seals. Comply with specified requirements for exposed edges.
- D. Smoke- and Draft-Control Door Assemblies: Listed and labeled for smoke and draft control, based on testing according to UL 1784.
- E. Particleboard-Core Doors:
1. Particleboard: ANSI A208.1, Grade LD-2, made with binder containing no urea-formaldehyde.
 2. Blocking: Provide wood blocking in particleboard-core doors as follows:
 - a. 5-inch (125-mm) top-rail blocking, in doors indicated to have closers.
 - b. 5-inch (125-mm) bottom-rail blocking, in doors and doors indicated to have kick, mop, or armor plates.
 - c. 4-1/2-by-10-inch (114-by-250-mm) lock blocks and 5-inch (125-mm) midrail blocking, in doors indicated to have exit devices.
- F. Structural-Composite-Lumber-Core Doors:
1. Structural Composite Lumber: WDMA I.S.10.
 - a. Screw Withdrawal, Face: 700 lbf (3100 N).
 - b. Screw Withdrawal, Edge: 400 lbf (1780 N).
- G. Mineral-Core Doors:
1. Core: Noncombustible mineral product complying with requirements of referenced quality standard and testing and inspecting agency for fire-protection rating indicated.
 2. Blocking: Provide composite blocking with improved screw-holding capability approved for use in doors of fire-protection ratings indicated as needed to eliminate through-bolting hardware, and as follows:
 - a. 5-inch (125-mm) top-rail blocking.
 - b. 5-inch (125-mm) bottom-rail blocking, in doors indicated to have protection plates.
 - c. 5-inch (125-mm) midrail blocking, in doors indicated to have armor plates.
 - d. 4-1/2-by-10-inch (114-by-250-mm) lock blocks and 5-inch (125-mm) midrail blocking, in doors indicated to have exit devices.

3. Edge Construction: At hinge stiles, provide laminated-edge construction with improved screw-holding capability and split resistance. Comply with specified requirements for exposed edges.
 - a. Screw-Holding Capability: 550 lbf (2440 N) per WDMA T.M.-10.

2.3 VENEER-FACED DOORS FOR TRANSPARENT FINISH

A. Interior Solid-Core Doors:

1. Grade: Custom, with Grade A faces.
2. Species: White Maple
3. Cut: Plain sawn/sliced.
4. Match between Veneer Leaves: Book match.
5. Assembly of Veneer Leaves on Door Faces: Balance match.
6. Exposed Vertical Edges: Same species as faces - edge Type A
7. Core:
 - a. Non-Rated Doors: Particleboard except provide doors with either glued-wood-stave or structural-composite-lumber cores instead of particleboard cores for doors with full light or 2 lights
 - b. Fire-Rated Doors: Mineral core.
8. Construction: Five plies. Stiles and rails are bonded to core, then entire unit is abrasive planed before veneering. Faces are bonded to core using a hot press.
9. WDMA I.S.1-A Performance Grade: Extra Heavy Duty
10. STC Rating for Acoustical Doors: Minimum 43.
11. Basis of Design Doors: Marshfield – Algoma Aspiro Series by Masonite Architectural, or equal.
12. Basis of Design Door, Acoustical Rated: Marshfield – Algoma Aspiro Series by Masonite Architectural, or equal with the following:
 - a. STC: 44
 - b. Non-rated single door
 - c. Perimeter Gaskets: Double row Pemko S-88
 - d. Bottom Seal/Sweep: Zero 360 or Pemko 211 door shoe
 - e. Threshold: not required
 - f. Door Weight 9.3 lbs/ft
 - g. Electric Raceway: Yes
 - h. Glazing: Max 300 sq. in, dual glazed acoustic glazing with ¼” and 3/8” thick laminated glass; flat metal stop DSR 44 sound molding.

2.4 ALUMINUM-FRAMED, TOP-HUNG SLIDING WOOD SOUND CONTROL DOOR ASSEMBLIES

- A. Acoustic Rating: Minimum STC 34 rated sound control assemblies tested at an independent acoustic laboratory in accordance to ASTM E90 Sealed-In-Place standard.
- B. Basis of Design Product: AD Systems OfficeSlide High Performance Barn (Sliding) Door System, or equal.
- C. Wall Thickness: 4-7/8”

- D. Frame and Door Assembly Components:
 - 1. Single Piece Top Track: Extruded aluminum track system with mounting brackets.
 - 2. Fascia: Extruded aluminum with matching integral end caps in square profile.
 - 3. Integral Soft-Closer: Soft and self-closing damper mechanism integrated with top track. Rated for 150K cycles.
 - 4. Concealed Door Bottom Floor Guide: Integral jamb floor guide.
 - 5. Acoustical Automatic Door Bottom.
 - 6. Sound Seal Sets: Integral to frame.
- E. Doors: Match door construction and finish as specified in this Section for other flush wood doors.
 - 1. Provide one side of door with surface mounted whiteboard as indicated on Drawings.
- F. Frames: Extruded aluminum "wrap" frame with integral vertical jamb (stile pocket) and acoustic seals.
 - 1. Finish: Clear anodized.
- G. Hardware: Self-latching lock with single action egress, with return to door tubular lever, finish US32D, AD6450P Office function (keyed lock with cylinder, ADA compliant thumbturn and back to back lever trim.
- H. Fabrication: Fabricate top-hung, sliding door assemblies in sizes, profiles, and configurations as indicated on Drawings.

2.5 LIGHT FRAMES AND LOUVERS

- A. Wood Beads for Light Openings in Wood Doors: Provide manufacturer's standard wood beads unless otherwise indicated.
 - 1. Wood Species: Same species as door faces.
 - 2. Profile: Manufacturer's standard shape.
 - 3. At wood-core doors with 20-minute fire-protection ratings, provide wood beads and metal glazing clips approved for such use.
- B. Wood-Veneered Beads for Light Openings in Fire-Rated Doors: Manufacturer's standard wood-veneered noncombustible beads matching veneer species of door faces and approved for use in doors of fire-protection rating indicated. Include concealed metal glazing clips where required for opening size and fire-protection rating indicated.
- C. Where Pyrostop glazing is scheduled to be inserted into openings in wood doors provide door manufacturer's special window kit to accommodate thickness of glazing unit.

2.6 FABRICATION

- A. Factory fit doors to suit frame-opening sizes indicated. Comply with clearance requirements of referenced quality standard for fitting unless otherwise indicated.

- B. Align and fit doors in frames with uniform clearances and bevels as indicated below. Machine doors for hardware. Seal edges of doors, edges of cutouts, and mortises after fitting and machining.
 - 1. Clearances: Provide 1/8 inch (3.2 mm) at heads, jambs, and between pairs of doors. Provide 1/8 inch (3.2 mm) from bottom of door to top of decorative floor finish or covering unless otherwise indicated. Where threshold is shown or scheduled, provide 5/8 inch (16 mm) from bottom of door to top of threshold unless otherwise indicated.
 - a. Comply with NFPA 80 for fire-rated doors.
 - 2. Bevel non-fire-rated doors 1/8 inch in 2 inches (3-1/2 degrees) at lock and hinge edges.
 - 3. Bevel fire-rated doors 1/8 inch in 2 inches (3-1/2 degrees) at lock edge; trim stiles and rails only to extent permitted by labeling agency.
- C. Factory machine doors for hardware that is not surface applied. Locate hardware to comply with DHI-WDHS-3. Comply with final hardware schedules, door frame Shop Drawings, BHMA-156.115-W, and hardware templates.
- D. Coordinate with hardware mortises in metal frames to verify dimensions and alignment before factory machining. Openings: Factory cut and trim openings through doors.
 - 1. Light Openings: Trim openings with moldings of material and profile indicated.
 - 2. Glazing: Factory install glazing in doors indicated to be factory finished. Comply with applicable requirements in Division 08 Section "Glazing."

2.7 FACTORY FINISHING

- A. General: Comply with referenced quality standard for factory finishing. Complete fabrication, including fitting doors for openings and machining for hardware that is not surface applied, before finishing.
 - 1. Finish faces, all four edges, edges of cutouts, and mortises. Stains and fillers may be omitted on bottom edges, edges of cutouts, and mortises.
- B. Factory finish doors.
- C. Transparent Finish:
 - 1. Grade: Premium.
 - 2. Finish: WDMA TR-6 and AWS system 11 catalyzed polyurethane.
 - 3. Staining: As selected by Architect.
 - 4. Effect: Semifilled finish, produced by applying an additional finish coat to partially fill the wood pores.
 - 5. Sheen: Satin

PART 3 - EXECUTION

3.1 EXAMINATION

- A. Examine doors and installed door frames, with Installer present, before hanging doors.

1. Verify that installed frames comply with indicated requirements for type, size, location, and swing characteristics and have been installed with level heads and plumb jambs.
2. Reject doors with defects.

B. Sliding Doors and Frames:

1. Examine wall openings and conditions, with Installer present, for plumb, level and square, and compliance with requirements for installation tolerances and other conditions affecting performance of the Work. Sliding door operation will be adversely affected by out-of-tolerance framing.
2. Examine surfaces to receive door bottom guide. Floor shall have no height variance throughout the complete sliding operation.

C. Proceed with installation only after unsatisfactory conditions have been corrected.

3.2 INSTALLATION

A. Hardware: For installation, see Division 08 Section "Door Hardware."

B. Installation Instructions: Install doors to comply with manufacturer's written instructions and referenced quality standard, and as indicated.

1. Install fire-rated doors according to NFPA 80.
2. Install smoke- and draft-control doors according to NFPA 105.

C. Factory-Fitted Doors: Align in frames for uniform clearance at each edge.

D. Factory-Finished Doors: Restore finish before installation if fitting or machining is required at Project site.

E. Aluminum-Framed, Top-Hung Sliding Wood Sound Control Door Assemblies:

1. Install frame components and sliding doors plumb, level, square, and in proper alignment.
2. Anchor sliding door assemblies securely in place to supports according to manufacturer's written installation instructions.

3.3 FIELD QUALITY CONTROL

A. Inspection Agency: Engage a qualified inspector to perform inspections and commissioning activities and to furnish reports to Architect.

B. Inspections:

1. Fire-Rated Door Inspections: Inspect each fire-rated door according to NFPA 80, Section 5.2.
2. Egress Door Inspections: Inspect each door equipped with panic hardware, each door equipped with fire exit hardware, each door located in an exit enclosure, each electrically controlled egress door, and each door equipped with special locking arrangements in accordance with NFPA 101, Section 7.2.1.15.

- C. Commissioning: Commissioning of all doors shall be performed by the installer supervised by an Architectural Hardware Consultant who is thoroughly knowledgeable of the various components and systems. Include the following:
 - 1. Testing of opening force, closing device, complete closure of the door within clearance tolerances, and full engagement of latch(es) where required by door type.
 - 2. Verify cleanliness of labels, fusible links and other components that cannot be painted.
 - 3. Functional testing of automatic-closing or power-operated fire door assemblies and electrically controlled latching hardware or release devices shall be coordinated with all components of the electrically controlled system.
 - 4. After all doors have been commissioned and prior their acceptance, the Architect, in consultation with the Owner, will select doors (at least one for each operational type) whose full range operation shall be demonstrated by the Contractor to the satisfaction of the Architect.
 - D. Repair or remove and replace installations where inspections indicate that they do not comply with specified requirements.
 - E. Reinspect repaired or replaced installations to determine if replaced or repaired door assembly installations comply with specified requirements.
 - F. Prepare and submit separate inspection report for each fire-rated door assembly indicating compliance with each item listed in NFPA 80.
 - G. Prepare and submit separate inspection report for each egress door assembly indicating compliance with each item listed in NFPA 101.
 - H. Prepare and submit commissioning report of all doors.
- 3.4 ADJUSTING
- A. Operation: Rehang or replace doors that do not swing or operate freely.
 - 1. Adjust sliding doors and hardware for smooth operation in accordance with manufacturer's written instructions without binding and with tight fit at contact points and seals. Sliding doors to close against walls without gaps.
 - B. Finished Doors: Replace doors that are damaged or that do not comply with requirements. Doors may be repaired or refinished if Work complies with requirements and shows no evidence of repair or refinishing.

END OF SECTION 081416

SECTION 082250 - POLYESTER FACED DOORS AND ALUMINUM FRAMING

PART 1 - GENERAL

1.1 SUMMARY

- A. This Section includes the following:
 - 1. Fiberglass reinforced polyester (FRP) faced doors
 - 2. Aluminum frames for FRP doors, including frames for sidelites and transoms.
 - 3. Installation of hardware (except surface mounted hardware).
- B. Related sections include the following:
 - 1. Division 07 Section "Joint Sealants" for joint sealants installed as part of aluminum entrance and storefront systems.
 - 2. Division 08 Section "Door Hardware."
 - 3. Division 08 Section "Glazing."

1.2 SYSTEM DESCRIPTION

- A. General: Provide polyester faced doors and aluminum framing systems capable of withstanding loads and thermal and structural movement requirements indicated without failure, based on testing manufacturer's standard units in assemblies similar to those indicated for this Project.
- B. Thermal Movements: Provide polyester faced doors and aluminum framing systems, including anchorage, that accommodate thermal movements of systems and supporting elements resulting from the following maximum change(range) in ambient and surface temperatures without buckling, damaging stresses on glazing, failure of joint sealants, damaging loads on fasteners, failure of doors or other operating units to function properly, and other detrimental effects.
 - 1. Temperature Change (Range): 120 deg F (67 deg C), ambient; 180 deg F (100 deg C), material surfaces.
- C. Structural-Support Movement: Provide polyester faced doors and aluminum framing systems that accommodate structural movements including, but not limited to, sway and deflection.
- D. Dimensional Tolerances: Provide polyester faced doors and aluminum framing systems that accommodate dimensional tolerances of building frame and other adjacent construction.

1.3 SUBMITTALS

- A. Product data including specifications, standard details, and installation recommendations for polyester faced doors and panels and aluminum frames including test reports certifying that products have been tested and comply with performance requirements, details of core and edge construction, trim for openings, and finish.
- B. Shop drawings showing fabrication and installation of polyester faced doors, panels and frames. Include elevations of door design types, details of construction, location and installation requirements of door hardware and reinforcements, and details of openings.
 - 1. Provide schedule of doors indicating sizes, locations, and other pertinent information using same reference numbers for details and openings as those on contract drawings.
- C. Samples for initial selection purposes in form of manufacturer's color charts showing full range of colors available for doors and panels.
- D. Samples for Verification Purposes: Submit 6" square samples of each color of face sheet specified and 12" long sections of aluminum extrusions with specified finish system applied. Where normal color and texture variations are to be expected, include 2 or more units in each set of samples showing limits of such variations.

1.4 QUALITY ASSURANCE

- A. Single Source Responsibility: Provide doors and frames produced by single manufacturer for entire Project.
- B. Manufacturer Qualifications: Provide product series that has produced by the manufacturer for at least five years, for similar building type and size as this project.
- C. Installer's Qualifications: Firm with not less than 4 years successful experience installing systems similar to those required.
- D. Fire Performance Characteristics: Where indicated, provide class "A" fiber reinforced polyester faces with the following surface burning characteristics as determined by testing identical products per ASTM E 84 by UL or other testing and inspecting organizations acceptable to authorities having jurisdiction.
 - 1. Flame Spread: 25 or less.
 - 2. Smoke Developed: 450 or less.
- E. Design Criteria: The construction documents are based on a specific polyester door faced and aluminum frame system. Other manufacturer's system of similar and equivalent nature will be acceptable when, in Architect's judgement, differences do not materially detract from design concept or intended performance.

1.5 DELIVERY, STORAGE AND HANDLING

- A. Deliver doors cardboard-wrapped or crated to provide protection during transit and job storage. Provide additional protection to prevent damage to surface finishes.

- B. Inspect doors upon delivery for damage. Minor damages may be repaired provided refinished items are equal in all respects to new work and acceptable to Architect; otherwise, remove and replace damaged items as directed.
- C. Store doors and frames at building site under cover. Place units on minimum 4-inches high wood blocking. Avoid use of non-vented plastic or canvas shelters which could create humidity chamber. If cardboard wrapper on door becomes wet, remove carton immediately. Provide 1/4-inches spaces between stacked doors to promote air circulation.
- D. Identify each door and frame with individual opening numbers which correlate with designation system used on shop drawings for door, frames, and hardware, using temporary, removable or concealed markings.

1.6 PROJECT CONDITIONS

- A. Field Measurements: Check openings by field measurement before fabrication to ensure proper fitting of work; show measurements on final shop drawings. Coordinate fabrication schedule with construction progress to avoid delay in work.
- B. Coordinate work of this section with that specified in Section 087100 to ensure proper installation of hardware.

1.7 WARRANTY

- A. Product Warranty: Provide manufacturer's standard written warranty agreeing to repair or replace polyester faced doors which fail in materials or workmanship within time period indicated below. Warranty shall include door manufacturer's guarantee that hardware installed by factory will be installed correctly and not come loose within time period indicated below.
 - 1. Warranty period for doors and finish, and hardware installed by factory is ten years after date of Substantial Completion.

PART 2 - PRODUCTS

2.1 MANUFACTURERS

- A. Manufacturer: Provide polyester faced doors, panels and aluminum frames manufactured by one of following:
 - 1. Special-Lite, Inc.
 - 2. Tubelite, Inc.
 - 3. Commercial Door Systems.

2.2 MATERIALS

- A. Aluminum Members: Alloy and temper recommended by manufacturer for strength, corrosion resistance, and application of required finish; comply with ASTM B 221 for extrusions and ASTM B 209 for sheet and plate.
- B. Steel Reinforcement: Complying with ASTM A 36 (ASTM A 36M)) for structural shapes, plates, and bars; ASTM A 611 for cold-rolled sheet and strip; or ASTM A 570 (ASTM A 570M) for hot-rolled sheet and strip.
- C. Fiberglass Reinforced Polyester Face Material: 0.120" minimum thickness, with color integral through full thickness of face sheet. Provide sandstone textured finish for doors and panels. Face material meeting the following performance criteria:
 - 1. Impact Strength of Face Sheets: ASTM D 256, Izod Impact Strength, 15 foot pounds per inch of notch.
 - 2. Abrasion Resistance of Face Sheets: ASTM D 1242, 25 cycles of Taber Abraser with CH-17 wheel with a 1000 gram load, not to exceed 0.029 percent weight loss.
 - 3. Hardness of Face Sheets: ASTM D 2583, Barcol Meter Hardness Test, not less than 55.
 - 4. Humidity Resistance of Face Sheets: ASTM D 570, water absorption not more than 0.40 percent weight gain after 24-hour immersion.
 - 5. Ultra-Violet Degradation: Only slight color change, and negligible change in surface gloss and other physical properties after exposure to 500,000 Langleys.
 - 6. Fire-Resistance and Flammability: Provide Class A rated faces for door faces of interior doors and for interior face of exterior doors and panels.
 - 7. Product: SpecLite 3 FRP by Special Lite, or equivalent.
 - 8. Per 2015 IBC 2603.4.1.7 for non-rated swing doors with plastic foam cores- provide a thermal barrier of not less than 0.032" thick aluminum or steel with basic thickness of not less than 0.016" between the foam core and FRP skin; or complying with NFPA 275 - per IBC 2603.4.
- D. Core Material: Urethane foam of 5 pounds per cubic foot density for doors and panels.
- E. Fasteners: Aluminum or stainless steel materials warranted by manufacturer to be non-corrosive and compatible with aluminum components, hardware, anchors and other components.
- F. Brackets and Reinforcements: Manufacturer's high-strength aluminum extrusions. Provide manufacturer's standard reinforcement for each type of hardware required.
- G. Bituminous Paint: Cold-applied asphalt-mastic paint complying with SSPC-Paint 12 requirements, except containing no asbestos, formulated for 30-mil (0.762-mm) thickness per coat.
- H. Spacers, Setting Blocks, Gaskets, and Bond Breakers: Manufacturer's standard permanent, nonmigrating types in hardness recommended by manufacturer, compatible with sealants, and suitable for system performance requirements.
- I. Framing system gaskets, sealants, and joint fillers as recommended by manufacturer for joint type.

- J. Sealants and joint fillers for joints at perimeter of entrance and storefront systems as specified in Division 07 Section "Joint Sealants."
- K. Glazing: 1" insulating glass units as specified in Division 08 Section "Glazing."

2.3 DOORS

- A. General: Provide manufacturer's standard flush and wide stile style doors as indicated on Drawings constructed of aluminum stiles and rails joined with steel tie rods, with polyester face sheets and foamed-in-place urethane inner core. Minimum thermal rating U-factor of 0.09.
 - 1. Basis of Design Product: Provide Sandstone FRP Flush Door Model SL-20 by Special Lite, or equivalent.
 - 2. Color shall be as selected by Architect.
- B. Provide extruded aluminum 2-7/16" tubular stiles designed to accept specified hardware and a minimum extruded aluminum 2-5/16" top and bottom rails with legs for interlocking rigidity weather bar. Minimum thickness of 1/16 inches at face and 1/8 inch at hinge and concealed vertical stiles.
 - 1. Meeting Stiles: Pile brush weatherseals. Extrude meeting stile to include integral pocket to accept pile brush weatherseals.
 - 2. Bottom of Door: Install bottom weather bar with nylon brush weatherstripping into extruded interlocking edge of bottom rail.
- C. Lock polyester face sheets in on all four sides by extruded interlocking edges which are integral part of stiles and rails. Snap in or applied door edge trim is not acceptable.
- D. Miter or mortise and tenon corner joints and mechanically fasten with reinforcing brackets that incorporate concealed minimum 3/8" galvanized steel tie-rods at top and bottom with aviation type nuts.
- E. Internally reinforce doors to receive specified hardware with .125 inch thick aluminum.
- F. Foam-in-place core after the door is completely assembled.
- G. Manufacture doors with cutouts for required vision lites. Provide screw-applied aluminum stops to match perimeter door rails.

2.4 FRAMES

- A. Standard Frame: Provide tubular extruded aluminum frame members, 2 by 4-1/2 inch in size unless otherwise indicated on drawings, with minimum 1/8 inch thick walls and closed back. Fabricate with mechanical joints using heavy inserted reinforcing plates and concealed tie-rods or j-bolts. Supply with 1/2 by 1-1/4 inch door stop, with heavy duty weathering pile included.

1. Provide Tube Frame with Applied Stops, Model SL-245, by Special Lite, or equivalent.
2. Finish: Clear anodized.

2.5 HARDWARE

- A. Hardware is specified in Section 087100.

2.6 FABRICATION

- A. Factory-prefit and premachine doors for all hardware and to fit frame opening sizes indicated with the following uniform clearances and bevels:
 1. Clearances: Not more than 1/8 inch at jambs and heads except between pairs of doors not more than 1/4 inch. Not more than 3/4 inch at bottom.
 2. Comply with final hardware schedules and door frame shop drawings and with hardware templates.
 3. Coordinate measurements of hardware mortises in metal frames to verify dimensions and alignment before proceeding with factory premachining.
- B. Complete fabrication, assembly, installation of hardware, finishing and other work before shipment to project site. Disassemble components only as necessary for shipment and installation. Field stick framing is not acceptable.
- C. Factory install vision lites and panels.
- D. Install hinges and all other hardware, with the exception of any surface-applied hardware such as door closer and locksets or push/pull hardware, at the manufacturer's plant.
 1. Locate hardware as indicated on final shop drawings or, if not indicated, in accordance with "Recommended Locations for Builder's Hardware on Standard Steel Doors and Frames," published by Door and Hardware Institute.
- E. Separate dissimilar metals with zinc chromate primer, bituminous paint, or other separator to prevent corrosion.
- F. Maintain accurate relation of planes and angles, hairline fit contacting members.
- G. Conceal fasteners where possible provide countersunk flat or oval heads for exposed screws and bolts.

2.7 ALUMINUM FINISHES

- A. General: Comply with NAAMM's "Metal Finishes Manual for Architectural and Metal Products" for recommendations relative to applying and designating finishes.
- B. Appearance of Finished Work: Variations in appearance of abutting or adjacent pieces are acceptable if they are within one-half of the range of approved Samples. Noticeable variations in the same piece are not acceptable. Variations in appearance of other

components are acceptable if they are within the range of approved Samples and are assembled or installed to minimize contrast.

- C. Finish designations prefixed by AA conform to the system established by the Aluminum Association for designating aluminum finishes.
- D. Class I, Clear Anodic Finish: AA-M12C22A41 (Mechanical Finish: nonspecular as fabricated; Chemical Finish: etched, medium matte; Anodic Coating: Architectural Class I, clear coating 0.018 mm or thicker) complying with AAMA 611.

PART 3 - EXECUTION

3.1 EXAMINATION

- A. Examine substrates and supports, with the Installer present, for compliance with requirements indicated, installation tolerances, and other conditions that affect installation of polyester faced doors. Correct unsatisfactory conditions before proceeding with the installation.
- B. Examine door frames prior to hanging door:
 - 1. Verify that frames comply with indicated requirements for type, size, location, and swing characteristics and have been installed with plumb jambs and level heads.
 - 2. Reject doors with defects.
- C. Do not proceed with installation until unsatisfactory conditions have been corrected.

3.2 INSTALLATION

- A. General: Comply with manufacturer's written instructions for protecting, handling, and installing FRP doors and aluminum framing systems. Do not install damaged components. Fit frame joints to produce hairline joints free of burrs and distortion. Rigidly secure nonmovement joints.
- B. Metal Protection: Where aluminum will contact dissimilar metals, protect against galvanic action by painting contact surfaces with primer or by applying sealant or tape recommended by manufacturer for this purpose. Where aluminum will contact concrete or masonry, protect against corrosion by painting contact surfaces with bituminous paint.
- C. Install framing components plumb and true in alignment with established lines and grades without warp or rack of framing members.
- D. Install doors and frames plumb and true in alignment with established lines and grades without warp or rack. Lubricate operating hardware and other moving parts according to hardware manufacturers' written instructions.
 - 1. Install surface-mounted hardware according to manufacturer's written instructions using concealed fasteners to greatest extent possible.

2. Install frames with anchors appropriate for wall conditions to anchor framing to wall materials. A minimum of five anchors up to 7'- 4" on jamb members, and one additional anchor for each 12 inches over that height.
- E. Construction Tolerances: Install doors and frames to comply with the following tolerances:
1. Variation from Plane: Do not exceed 1/16 inch in 12 feet of length or 1/8 inch in any total length.
 2. Offset from Alignment: The maximum offset from true alignment between two identical members abutting end to end in line shall not exceed 1/16 inch.
 3. Diagonal Measurements: The maximum difference in diagonal measurements shall not exceed 1/8 inch.
 4. Offset at Corners: The maximum out-of-plane offset of framing at corners shall not exceed 1/32 inch.
- F. Separate aluminum and other corrodible metal surfaces from sources of corrosion or electrolytic action at points of contact with other materials.
1. Zinc or cadmium plate steel anchors and other unexposed fasteners after fabrication.
 2. Paint dissimilar metals where drainage from them passes over aluminum.
 3. Paint aluminum surfaces in contact with mortar, concrete or other masonry with alkali resistant coating.
 4. Paint wood and similar absorptive material in contact with aluminum and exposed to the elements or otherwise subject to wetting, with two coats of aluminum house paint. Seal joints between the materials with sealant.
- G. Drill and tap frames and doors and apply surface-mounted hardware items. Comply with hardware manufacturer's instructions and template requirements. Use concealed fasteners wherever possible. Refer to Section 087100 for additional installation requirements.
- H. Install perimeter sealant to comply with requirements of Division 07 Section "Joint Sealants," unless otherwise indicated.
- 3.3 ADJUSTING, CLEANING AND PROTECTION
- A. Adjust operating hardware to function properly, for smooth operation without binding, and for weathertight closure.
 - B. Clean complete system, inside and out, promptly after installation, exercising care to avoid damage to coatings.
 - C. Institute protective measures required throughout remainder of construction period to ensure polyester faced doors will be without damage and deterioration, other than normal weathering, at time of acceptance.

END OF SECTION 082250

SECTION 083113 - ACCESS DOORS AND FRAMES

PART 1 - GENERAL

1.1 SUMMARY

A. Section Includes:

1. Wall access doors and frames for interior locations.
2. Fire-rated wall access doors and frames for interior locations
3. Ceiling access doors and frames for interior locations.
4. Fire-rated ceiling access doors and frames for interior locations.

B. Locations and Quantities of Access Doors: Not all access doors are shown on the Drawings. It is the intent of this section that access doors be provided wherever access is required for operation and maintenance of concealed equipment, dampers, valves, controls or similar devices.

C. Cylinders for access doors are specified in Division 08 Section "Door Hardware."

D. Related Requirements:

1. Division 07 Section "Roof Accessories" for roof hatches.
2. Division 23 Section "Air Duct Accessories" for heating and air-conditioning duct access doors.

1.2 ACTION SUBMITTALS

A. Product Data: For each type of product. Include construction details, fire ratings, materials, individual components and profiles, and finishes.

B. Shop Drawings:

1. Include plans, elevations, sections, details, and attachments to other work.
2. Detail fabrication and installation of access doors and frames for each type of substrate.

C. Samples: For each door face material, at least 3 by 5 inches (75 by 125 mm) in size, in specified finish.

D. Product Schedule: Provide complete access door and frame schedule, including types, locations, sizes, latching or locking provisions, and other data pertinent to installation.

1.3 COORDINATION

A. Verification: Determine specific locations and sizes for access doors needed to gain access to concealed equipment, and indicate on schedule specified in "Submittals" Article

PART 2 - PRODUCTS

2.1 PERFORMANCE REQUIREMENTS

- A. Fire-Rated Access Doors and Frames: Units complying with NFPA 80 that are identical to access door and frame assemblies tested for fire-test-response characteristics according to the following test method and that are listed and labeled by UL or another testing and inspecting agency acceptable to authorities having jurisdiction:

1. NFPA 252 or UL 10B for fire-rated access door assemblies installed vertically.
2. NFPA 288 for fire-rated access door assemblies installed horizontally.

2.2 PRODUCTS, GENERAL

- A. Source Limitations: Obtain each type of access door and frame from single source from single manufacturer.

2.3 ACCESS DOORS AND FRAMES FOR WALLS AND CEILINGS

- A. Manufacturers: Subject to compliance with requirements, available manufacturers offering products that may be incorporated into the Work include, but are not limited to, the following:

1. Babcock-Davis.
2. J. L. Industries, Inc.; Div. of Activar Construction Products Group.
3. Karp Associates, Inc.
4. Larsen's Manufacturing Company.
5. Milcor Inc.
6. Nystrom, Inc.

- B. Flush Access Doors, with Exposed Trim, for CMU Surfaces: Units consisting of frame with exposed trim, door, hardware, and complying with the following requirements

1. Basis-of-Design Product: Karp Model DSC-214M, Universal Flush Access Door.
2. Assembly Description: Fabricate door to fit flush to frame. Provide flange integral with frame, 3/4 inch (19 mm) wide, overlapping surrounding finished surface.
3. Locations: Provide at non-rated concrete block walls.
4. Uncoated Steel Sheet for Door: Nominal 0.074 inch (1.9 mm), 14 gage.
 - a. Finish: Factory prime.
5. Stainless-Steel Sheet for Door for Toilet Rooms, Shower Rooms, and Other Wet Areas: Nominal 0.074 inch (1.9 mm), 14 gage; No. 4 finish.
6. Frame Material: Nominal 0.060 inch (1.52 mm), 16 gage
7. Hinges: Concealed continuous piano hinge.
8. Latches: Self-latching key-operated bolt type, with interior release; for locking.

- C. Trimless, Flush Access Doors for Gypsum Board Surfaces: Units consisting of frame, concealed edge trim, door, hardware, and complying with the following requirements:

1. Basis-of-Design Product: Karp KDW for drywall
 2. Assembly Description: Fabricate door to fit flush to frame. Provide frame with gypsum board beads for concealed flange installation.
 3. Locations: Provide at non-rated gypsum board walls and ceilings.
 4. Uncoated Steel Sheet for Door: Nominal 0.074 inch (1.9 mm), 14 gage.
 - a. Finish: Factory prime.
 5. Stainless-Steel Sheet for Door for Toilet Rooms, Shower Rooms, and Other Wet Areas: Nominal 0.074 inch (1.9 mm), 14 gage; No. 4 finish.
 6. Frame Material: Nominal 0.060 inch (1.52 mm), 16 gage.
 7. Hinges: Concealed continuous piano hinge.
 8. Latches: Self-latching key-operated bolt type, with interior release; for locking.
- D. Recessed Doors for Acoustical Ceiling Tiles: Units consisting of frame with no exposed trim, recessed door to receive tile, hardware, and complying with the following requirements.
1. Basis-of-Design Product: Karp, Model DSC-210, Recessed Acoustical Ceiling Tile Access Doors.
 2. Locations: Provide at non-rated acoustical ceilings tiles.
 3. Uncoated Steel Sheet for Door: Nominal 0.060 inch (1.52 mm), 16 gage thick steel sheet; recessed 1-inch (25.4 mm).
 - a. Finish: Factory prime.
 4. Stainless-Steel Sheet for Door for Toilet Rooms, Shower Rooms, and Other Wet Areas: Nominal 0.060 inch (1.52 mm), 16 gage; No. 4 finish.
 5. Frame Material: Nominal 0.074 inch (1.9 mm), 14 gage.
 6. Hinges: Concealed, pivoting-rod type.
 7. Latches: Self-latching key-operated bolt type, with interior release; for locking.
- E. Insulated, Fire-Rated Access Doors for Drywall Walls and Ceilings: Units consisting of frame with gypsum board bead concealed edge trim, self-latching insulated door, and hardware, and complying with the following requirements:
1. Basis-of-Design Product: Karp, Model KRP-350FR, Insulated Fire Rated Access Door, with Drywall Bead, for Walls and Ceilings.
 2. Assembly Description: Fabricate door to fit flush to frame, with a core of mineral-fiber insulation enclosed in sheet metal. Provide self-latching door with automatic closer and interior latch release.
 3. Locations: Provide at rated gypsum board walls and ceilings.
 4. Fire-Resistance Ratings:
 - a. Walls: 1-1/2 hours.
 - b. Ceilings: 3 hours.
 5. Uncoated Steel Sheet for Door: 20 ga., 0.0359-inch- (0.91-mm-) thick steel sheet, welded pan type, filled with 2-inch (50 mm) thick fire-rated mineral-fiber insulation.
 - a. Finish: Factory prime.
 6. Stainless-Steel Sheet for Door for Toilet Rooms, Shower Rooms, and Other Wet Areas: Same gage and style as steel door; with No. 4 finish.

7. Frame Material: 16 ga., 0.0598-inch- (1.52-mm-) thick steel sheet, 1-inch (25.4 mm) wide, surrounded by galvanized drywall bead.
 8. Hinges: Concealed continuous piano hinge.
 9. Hardware: Self-latching key-operated bolt type, with interior release; for locking.
- F. Insulated, Fire-Rated Access Doors for CMU Walls: Units consisting of frame with exposed edge trim, self-latching insulated door, and hardware, and complying with the following requirements:
1. Basis-of-Design Product: Karp, Model KRP-150FR, Insulated Fire Rated Access Door, with Exposed Flange, for Walls and Ceilings.
 2. Assembly Description: Fabricate door to fit flush to frame, with a core of mineral-fiber insulation enclosed in sheet metal. Provide flange integral with frame, 1 inch (25 mm) wide, overlapping surrounding finished surface. Provide self-latching door with automatic closer and interior latch release.
 3. Locations: Provide at rated concrete block walls.
 4. Fire-Resistance Ratings:
 - a. Walls: 1-1/2 hours.
 5. Uncoated Steel Sheet for Door: 20 ga., 0.0359-inch- (0.91-mm-) thick steel sheet, welded pan type, filled with 2-inch (50 mm) thick fire-rated mineral-fiber insulation.
 - a. Finish: Factory prime.
 6. Stainless-Steel Sheet for Door for Toilet Rooms, Shower Rooms, and Other Wet Areas: Same gage and style as steel door; with No. 4 finish.
 7. Frame Material: 16 ga., 0.0598-inch- (1.52-mm-) thick steel sheet, 1-inch (25.4 mm) wide exposed trim.
 8. Hinges: Concealed continuous piano hinge.
 9. Hardware: Self-latching key-operated bolt type, with interior release; for locking.
- G. Hardware:
1. Lock: Cylinder, keyed alike for project
 2. Lock for Fire Rated Access Doors: Rim cylinder.
 - a. Lock Preparation: Prepare door panel to accept cylinder specified in Section 087100 "Door Hardware."

2.4 MATERIALS

- A. Steel Plates, Shapes, and Bars: ASTM A 36/A 36M.
- B. Steel Sheet: Uncoated or electrolytic zinc coated, ASTM A 879/A 879M, with cold-rolled steel sheet substrate complying with ASTM A 1008/A 1008M, Commercial Steel (CS), exposed.
- C. Metallic-Coated Steel Sheet: ASTM A 653/A 653M, Commercial Steel (CS), Type B; with minimum G60 (Z180) or A60 (ZF180) metallic coating.

- D. Stainless-Steel Sheet, Strip, Plate, and Flat Bars: ASTM A 666, Type 304. Remove tool and die marks and stretch lines or blend into finish.
- E. Aluminum Extrusions: ASTM B 221 (ASTM B 221M), Alloy 6063-T5.
- F. Aluminum Plate and Sheet: ASTM B 209 (ASTM B 209M), Alloy 6061-T6.
- G. Frame Anchors: Same type as door face.
- H. Inserts, Bolts, and Anchor Fasteners: Hot-dip galvanized steel according to ASTM A 153/A 153M or ASTM F 2329.

2.5 FABRICATION

- A. General: Provide access door and frame assemblies manufactured as integral units ready for installation.
- B. Metal Surfaces: For metal surfaces exposed to view in the completed Work, provide materials with smooth, flat surfaces without blemishes. Do not use materials with exposed pitting, seam marks, roller marks, rolled trade names, or roughness.
- C. Doors and Frames: Grind exposed welds smooth and flush with adjacent surfaces. Furnish attachment devices and fasteners of type required to secure access doors to types of supports indicated.
 - 1. For concealed flanges with drywall bead, provide edge trim for gypsum board securely attached to perimeter of frames.
 - 2. For concealed flanges with plaster bead for full-bed plaster applications, provide zinc-coated expanded metal lath and exposed casing bead welded to perimeter of frames.
 - 3. Provide mounting holes in frames for attachment of units to metal or wood framing.
 - 4. Provide mounting holes in frame for attachment of masonry anchors.
- D. Recessed Access Doors: Form face of panel to provide recess for application of applied finish. Reinforce panel as required to prevent buckling.
- E. Latching Mechanisms: Furnish number required to hold doors in flush, smooth plane when closed.
 - 1. Non-Rated Doors: For cylinder locks, furnish two keys per lock and key all locks alike.
 - 2. Fire-Rated Doors: Cylinder and keys are specified in Section 087100 "Door Hardware."

2.6 FINISHES

- A. Comply with NAAMM's "Metal Finishes Manual for Architectural and Metal Products" for recommendations for applying and designating finishes.

- B. Protect mechanical finishes on exposed surfaces from damage by applying a strippable, temporary protective covering before shipping.
- C. Appearance of Finished Work: Noticeable variations in same piece are not acceptable. Variations in appearance of adjoining components are acceptable if they are within the range of approved Samples and are assembled or installed to minimize contrast.
- D. Steel and Metallic-Coated-Steel Finishes:
 - 1. Factory Prime: Apply manufacturer's standard, VOC-free, electrostatic-applied powder coat finish immediately after surface preparation and pretreatment.
- E. Stainless-Steel Finishes:
 - 1. Surface Preparation: Remove tool and die marks and stretch lines, or blend into finish.
 - 2. Polished Finishes: Grind and polish surfaces to produce uniform finish, free of cross scratches.
 - a. Run grain of directional finishes with long dimension of each piece.
 - b. When polishing is completed, passivate and rinse surfaces. Remove embedded foreign matter and leave surfaces chemically clean.
 - c. Directional Satin Finish: No. 4.
- F. Aluminum Finishes:
 - 1. Mill finish and factory primed, as specified.

PART 3 - EXECUTION

3.1 EXAMINATION

- A. Examine substrates for compliance with requirements for installation tolerances and other conditions affecting performance of the Work.
- B. Proceed with installation only after unsatisfactory conditions have been corrected.

3.2 INSTALLATION

- A. Comply with manufacturer's written instructions for installing access doors and frames.
- B. Set frames accurately in position and attach securely to supports with plane of face panels aligned with adjacent finish surfaces.
- C. Install doors flush with adjacent finish surfaces or recessed to receive finish material.

3.3 ADJUSTING

- A. Adjust doors and hardware, after installation, for proper operation.

- B. Remove and replace doors and frames that are warped, bowed, or otherwise damaged.

END OF SECTION 083113

SECTION 083326 - OVERHEAD COILING DOORS

PART 1 - GENERAL

1.1 SUMMARY

- A. This Section includes the following types of overhead coiling doors:
 - 1. Insulated service doors, motor operated.
 - 2. Insulated service door, manual operation.
- B. Related Sections include the following:
 - 1. Division 26 Sections for disconnect switches and circuit breakers for powered operators.

1.2 DEFINITIONS

- A. Operation Cycle: One complete cycle of a door begins with the door in the closed position. The door is then moved to the open position and back to the closed position.

1.3 PERFORMANCE REQUIREMENTS

- A. Structural Performance: Provide overhead coiling doors capable of withstanding the effects of gravity loads and stresses without evidencing permanent deformation of door components.
 - 1. Exterior Wind Load: Uniform pressure (velocity pressure) of 20 lbf/sq. ft. (960 Pa), acting inward and outward.
- B. Operation-Cycle Requirements: Design overhead coiling door components and operator to operate for not less than 100,000 cycles.
- C. Air Infiltration Performance: Provide overhead coiling doors with maximum air infiltration rate of 1.0 CFM/SQ FT when tested in accordance with NFRC 400 or with ASTM E283 at 1.57psf.

1.4 ACTION SUBMITTALS

- A. Product Data: For each type and size of overhead coiling door and accessory. Include details of construction relative to materials, dimensions of individual components, profiles, and finishes. Provide roughing-in diagrams, operating instructions, and maintenance information. Include the following:
 - 1. Setting drawings, templates, and installation instructions for built-in or embedded anchor devices.
 - 2. Summary of forces and loads on walls and jambs.

3. Motors: Show nameplate data and ratings; characteristics; mounting arrangements; size and location of winding termination lugs, conduit entry, and grounding lug; and coatings.
 - B. Shop Drawings: For special components and installations not dimensioned or detailed in manufacturer's data sheets.
 1. Wiring Diagrams: Detail wiring for power, signal, and control systems. Differentiate between manufacturer-installed and field-installed wiring and between components provided by door manufacturer and those provided by others.
 - C. Samples for Initial Selection: Manufacturer's color charts showing full range of colors available for units with factory-applied finishes
- 1.5 INFORMATIONAL SUBMITTALS
- A. Installer Certificates: Signed by manufacturer certifying that installers comply with specified requirements.
- 1.6 QUALITY ASSURANCE
- A. Installer Qualifications: Engage an experienced installer who is an authorized representative of the overhead coiling door manufacturer for both installation and maintenance of units required for this Project.
 - B. Source Limitations: Obtain overhead coiling doors through one source from a single manufacturer.
 1. Obtain operators and controls from the overhead coiling door manufacturer.
 - C. Listing and Labeling: Provide electrically operated fixtures specified in this Section that are listed and labeled.
 1. The Terms "Listed" and "Labeled": As defined in NFPA 70, Article 100.
- 1.7 WARRANTY
- A. Special Warranty: Manufacturer's standard form, signed by manufacturer, Installer, and Contractor, in which manufacturer agrees to repair or replace doors that are defective in materials or workmanship, for the following period:
 1. Door Assemblies: Two years.
 2. Motors: One year

PART 2 - PRODUCTS

2.1 MANUFACTURERS

- A. Basis of Design Products: Provide specified products of Cornell Iron Works Inc. or equal from one of the following manufacturers:
1. The Cookson Company.
 2. Raynor Garage Doors
 3. Pacific Rolling Door Co.
 4. Overhead Door Corporation.
 5. Wayne-Dalton Corp.
 6. Windsor Door; A United Dominion Company.

2.2 DOOR CURTAIN MATERIALS AND CONSTRUCTION

- A. Basis of Design Product: Thermiser Insulated Rolling Door Model ESD20 by Cornell in aluminum, or equal.
- B. Door Curtain: Fabricate overhead coiling door curtain of interlocking slats, designed to withstand wind loading indicated, in a continuous length for width of door without splices. Unless otherwise indicated, provide slats of material thickness recommended by door manufacturer for performance, size, and type of door indicated, and as follows:
1. Aluminum Door Curtain Slats: Double skin interlocking roll formed interior and exterior metal slats with foamed-in-place insulation between slats.
 - a. Profile: Manufacturer's standard flat-profile slats
 - b. Thickness: Minimum .050".
 - c. Insulation: 7/8" thick closed cell pressure foamed in place urethane insulation, Min R value of 8. Foam shall meet the following criteria:
 - 1) Flame Spread Index of 0
 - 2) Smoke Developed Index of 10 as tested per ASTM E84
 - 3) CFC-free process with an Ozone Depletion Potential rating of 0
 - 4) Meets foam plastic insulation requirements of the 2012 IBC®, section 2603.
 - d. Finish: Three-Coat PVDF.
- C. Service Door Windlocks and Endlocks: Malleable-iron castings galvanized after fabrication, secured to curtain slats with galvanized rivets, or high-strength nylon. Provide locks on not less than alternate curtain slats for curtain alignment and resistance against lateral movement
- D. Service Door Bottom Bar: Consisting of 2 angles, each not less than 1-1/2 by 1-1/2 by 1/8 inch (38 by 38 by 3 mm) thick, either galvanized or stainless-steel extrusions to suit type of curtain slats.
- E. Service Door Curtain Jamb Guides: Fabricate curtain jamb guides of steel angles, or channels and angles, with sufficient depth and strength to retain curtain, to allow curtain to operate smoothly, and to withstand loading. Build up units with not less than 3/16-inch- (5-mm-) thick, galvanized steel sections complying with ASTM A 36 (ASTM A 36M), and ASTM A 123. Slot bolt holes for guide adjustment. Provide removable stops on guides to prevent overtravel of curtain and a continuous bar for holding windlocks.

- F. Pass Doors: Provide hollow metal man door and hinged frame integrated into the curtain of the door, in size as indicated on Drawings. Provide in color as selected by Architect.

2.3 HOODS AND ACCESSORIES

- A. Hood: Form to entirely enclose coiled curtain and operating mechanism at opening head. Contour to suit end brackets to which hood is attached. Roll and reinforce top and bottom edges for stiffness. Provide closed ends for surface-mounted hoods and fascia for any portion of between-jamb mounting projecting beyond wall face. Provide intermediate support brackets as required to prevent sag.
- B. Weatherseals: Provide replaceable, adjustable, continuous, compressible weather-stripping gaskets fitted to bottom and top of doors, unless otherwise indicated. At door head, use 1/8-inch- (3-mm-) thick, replaceable, continuous sheet secured to inside of hood.
 - 1. In addition, provide replaceable, adjustable, continuous, flexible, 1/8-inch- (3-mm-) thick seals of flexible vinyl, rubber, or neoprene at door jambs for a weathertight installation.
- C. Push/Pull Handles: For push-up-operated or emergency-operated doors, provide galvanized steel lifting handles on each side of door.
 - 1. Provide pull-down straps or pole hooks for doors more than 84 inches (2130 mm) high.
- D. Fabricate locking device assembly with lock, spring-loaded dead bolt, operating handle, cam plate, and adjustable locking bar to engage through slots in tracks.
 - 1. Locking Bars: Single-jamb side, operable from inside only.
 - 2. Provide lock cylinder to match cylinders and keying of building as specified in Division 08 Section "Door Hardware."

2.4 COUNTERBALANCING MECHANISM

- A. General: Counterbalance doors by means of adjustable-tension steel helical torsion spring, mounted around a steel shaft and contained in a spring barrel connected to door curtain with required barrel rings. Use grease-sealed bearings or self-lubricating graphite bearings for rotating members.
- B. Counterbalance Barrel: Fabricate spring barrel of hot-formed, structural-quality, welded or seamless carbon-steel pipe, of sufficient diameter and wall thickness to support rolled-up curtain without distortion of slats and to limit barrel deflection to not more than 0.03 in./ft. (2.5 mm/m) of span under full load.
- C. Provide spring balance of one or more oil-tempered, heat-treated steel helical torsion springs. Size springs to counterbalance weight of curtain, with uniform adjustment

accessible from outside barrel. Provide cast-steel barrel plugs to secure ends of springs to barrel and shaft.

- D. Fabricate torsion rod for counterbalance shaft of cold-rolled steel, sized to hold fixed spring ends and carry torsional load.
- E. Brackets: Provide mounting brackets of manufacturer's standard design, either cast-iron or cold-rolled steel plate with bell-mouth guide groove for curtain.

2.5 MANUAL DOOR OPERATORS

- A. Manual Chain Hoist: Provide chain hoist operator with endless steel chain, chain pocket wheel and guard, geared reduction unit, and chain keeper secured to guide. Chain hoist shall include integral brake mechanism that will immediately stop upward or downward travel and maintain the door in a stationary position when the hand chain is released by the user.
 - 1. Basis of Design Product: ControlGard by Cornell or equal.
 - 2. Location: Provide for basement areaway location.

2.6 MOTOR DOOR OPERATORS

- A. General: Electric door operator assembly of size and capacity recommended and provided by door manufacturer for door specified, with electric motor and factory-rewired motor controls, starter, gear-reduction unit, solenoid-operated brake, clutch, remote-control stations, control devices, integral gearing for locking door, and accessories required for proper operation.
 - 1. Comply with NFPA 70.
 - 2. Provide control equipment complying with NEMA ICS 1, NEMA ICS 2, and NEMA ICS 6, with NFPA 70 Class 2 control circuit, maximum 24 V, ac or dc.
 - 3. Cycle Requirements: Maximum 20 times per day.
 - 4. Location: Provide for East Facade and Gym locations.
- B. Disconnect Device: Provide hand-operated disconnect or mechanism for automatically engaging chain and sprocket operator and releasing brake for emergency manual operation while disconnecting motor without affecting timing of limit switch. Mount disconnect and operator so they are accessible from floor level. Include interlock device to automatically prevent motor from operating when emergency operator is engaged.
- C. Design operator so motor may be removed without disturbing limit-switch adjustment and without affecting emergency auxiliary operator.
- D. Motor-Operator Type: Provide wall-, hood-, or bracket-mounted, jackshaft-type door operator unit consisting of electric motor, enclosed lubricated gear drive, and chain and sprocket secondary drive.
- E. Electric Motors: Provide high-starting torque, reversible, continuous-duty, Class A insulated, electric motors complying with NEMA MG 1; with overload protection; sized to

start, accelerate, and operate door in either direction from any position, at not less than 6 in/sec (15 cm/s) and not more than 9 in/sec (23 cm/s), without exceeding nameplate ratings or service factor.

1. Electrical Characteristics: Polyphase, 120V, 60Hz. Coordinate wiring requirements and electrical characteristics of motors with building electrical system.
2. Provide motor rating (hp) as recommended by manufacturer for size and type of door.

F. Limit Switches: Provide adjustable switches, interlocked with motor controls and set to automatically stop door at fully opened and fully closed positions.

G. Remote-Control Station: Provide momentary-contact, three-button control station with push-button controls labeled "Open," "Close," and "Stop."

1. Interior units, full-guarded, surface-mounted, heavy-duty type, with general-purpose NEMA ICS 6, Type 1 enclosure.

H. Emergency Manual Operation: Equip each electrically powered door with capability for emergency manual operation by use of disconnect cable for auxiliary push-up operation.

I. Obstruction Detection Device: Provide each motorized door with indicated external automatic safety sensor capable of protecting full width of door opening. Activation of sensor immediately stops and reverses downward door travel.

1. Sensor Edge: Provide each motorized door with an automatic safety sensor edge, located within astragal mounted to bottom bar. Contact with sensor immediately stops and reverses downward door travel. Connect to control circuit using manufacturer's standard take-up reel or self-coiling cable.
 - a. Provide electrically actuated automatic bottom bar.

2.7 FINISHES, GENERAL

A. General: Comply with NAAMM's "Metal Finishes Manual for Architectural and Metal Products" for recommendations for applying and designating finishes.

B. Appearance of Finished Work: Variations in appearance of abutting or adjacent pieces are acceptable if they are within one-half of the range of approved Samples. Noticeable variations in the same piece are not acceptable. Variations in appearance of other components are acceptable if they are within the range of approved Samples and are assembled or installed to minimize contrast..

2.8 ALUMINUM FINISHES

A. Finish designations prefixed by AA conform to the system established by the Aluminum Association for designating aluminum finishes.

- B. Superior-Performance Organic Finish, Three-Coat PVDF: Fluoropolymer finish complying with AAMA 2605 and containing not less than 70 percent PVDF resin by weight in both color coat and clear topcoat.
 - 1. Prepare, pretreat, and apply coating to exposed metal surfaces to comply with coating and resin manufacturers' written instructions.
 - 2. Color and Gloss: As selected by Architect from industry custom or standard full range.

PART 3 - EXECUTION

3.1 EXAMINATION

- A. Examine substrates areas and conditions, with Installer present, for compliance with requirements for substrate construction and other conditions affecting performance of the Work.
- B. Examine locations of electrical connections.
- C. Proceed with installation only after unsatisfactory conditions have been corrected.

3.2 INSTALLATION

- A. General: Install door and operating equipment complete with necessary hardware, jamb and head mold strips, anchors, inserts, hangers, and equipment supports according to Shop Drawings, manufacturer's written instructions, and as specified.
- B. Install overhead coiling doors, hoods, and operators at the mounting locations indicated for each door.
- C. Accessibility: Install overhead coiling doors, switches, and controls along accessible routes in compliance with regulatory requirements for accessibility.

3.3 ADJUSTING

- A. Lubricate bearings and sliding parts; adjust doors to operate easily, free from warp, twist, or distortion and fitting weathertight for entire perimeter.

3.4 DEMONSTRATION

- A. Startup Services: Engage a factory-authorized service representative to perform startup services and to train Owner's maintenance personnel as specified below:
 - 1. Test and adjust controls and safeties. Replace damaged and malfunctioning controls and equipment.
 - 2. Train Owner's maintenance personnel on procedures and schedules related to startup and shutdown, troubleshooting, servicing, preventive maintenance, and procedures for testing and resetting release devices.

3. Schedule training with Owner with at least 7 days' advance notice.

END OF SECTION 083326

SECTION 083329 - OVERHEAD COILING GRILLES

PART 1 - GENERAL

1.1 SUMMARY

A. Section Includes:

1. Open-curtain overhead coiling grilles.

B. Related Sections:

1. Division 05 Section "Metal Fabrications" for miscellaneous steel supports.
2. Division 26 Section "Conductors and Cables" for electrical service and connections for powered operators, and accessories.
3. Division 26 Section "Disconnect Switches and Circuit Breakers" for disconnect switches and circuit breakers for powered operators

1.2 PERFORMANCE REQUIREMENTS

- A. Operation Cycles: Provide overhead coiling grille components and operators capable of operating for not less than number of cycles indicated for each grille. One operation cycle is complete when a grille is opened from the closed position to the fully open position and returned to the closed position.

1.3 ACTION SUBMITTALS

- A. Product Data: For each type and size of overhead coiling grille and accessory. Include the following:

1. Construction details, material descriptions, dimensions of individual components, profiles for curtain components, and finishes.
2. Motors: Show nameplate data and ratings; characteristics; mounting arrangements; size and location of winding termination lugs, conduit entry, and grounding lug; and coatings.

- B. Shop Drawings: For each installation and for special components not dimensioned or detailed in manufacturer's product data. Include plans, elevations, sections, details, and attachments to other work.

1. Detail equipment assemblies and indicate dimensions, weights, loads, required clearances, method of field assembly, components, and location and size of each field connection.
2. Wiring Diagrams: Detail wiring for power, signal, and control systems. Differentiate between manufacturer-installed and field-installed wiring and between components provided by grille manufacturer and those provided by others

1.4 INFORMATIONAL SUBMITTALS

- A. Qualification Data: For qualified Installer.
- B. Maintenance Data: For overhead coiling grilles to include in maintenance manuals.

1.5 QUALITY ASSURANCE

- A. Installer Qualifications: Manufacturer's authorized representative who is trained and approved for both installation and maintenance of units required for this Project.
- B. Source Limitations: Obtain overhead coiling grilles through one source from a single manufacturer.
 - 1. Obtain operators and controls from the overhead coiling grille manufacturer.
- C. Regulatory Requirements: Comply with applicable provisions in the U.S. Architectural & Transportation Barriers Compliance Board's ADA-ABA Accessibility Guidelines.
- D. Electrical Components, Devices, and Accessories: Listed and labeled as defined in NFPA 70, by a qualified testing agency, and marked for intended location and application.

1.6 WARRANTY

- A. Special Warranty: Manufacturer's standard form, signed by manufacturer, Installer, and Contractor, in which manufacturer agrees to repair or replace grilles that are defective in materials or workmanship, for the following period:
 - 1. Grille Assemblies: Two years.
 - 2. Motors: One year.

PART 2 - PRODUCTS

2.1 MANUFACTURERS

- A. Manufacturers: Overhead coiling grilles by Cornell Iron Works, Inc. have been used as the Basis of Design. Provide Basis of Design Product or equal product by one of the following:
 - 1. McKeon, Inc.
 - 2. Raynor.
 - 3. Windsor Door.

2.2 GRILLE CURTAIN MATERIALS AND CONSTRUCTION

- A. Open-Curtain Grilles: Fabricate metal grille curtain as an open network of horizontal rods, spaced at regular intervals, that are interconnected with vertical links, which are formed and spaced as indicated and are free to rotate on the rods.
 - 1. Grille Curtain: Type 304 stainless steel.
- B. Endlocks: Continuous end links, chains, or other devices at ends of rods; locking and retaining grille curtain in guides against excessive pressures, maintaining grille curtain alignment, and preventing lateral movement.
- C. Bottom Bar: Manufacturer's standard continuous channel or tubular shape, finished to match grille.
- D. Grille Curtain Jamb Guides: Manufacturer's standard shape having curtain groove with return lips or bars to retain curtain. Provide continuous integral wear strips to prevent metal-to-metal contact and to minimize operational noise; with removable stops on guides to prevent overtravel of curtain.

2.3 HOODS AND ACCESSORIES

- A. General: Form sheet metal hood to entirely enclose coiled curtain and operating mechanism at opening head. Contour to fit end brackets to which hood is attached. Roll and reinforce top and bottom edges for stiffness. Form closed ends for surface-mounted hoods and fascia for any portion of between-jamb mounting that projects beyond wall face. Equip hood with intermediate support brackets as required to prevent sagging.
 - 1. Hood Material: Type 304 stainless steel.
- B. Mounting Frame: Manufacturer's standard mounting frame designed to support grille; factory fabricated from ASTM A 36/A 36M structural-steel tubes or shapes, hot-dip galvanized per ASTM A 123/A 123M; fastened to floor and structure above grille; to be built into wall construction; and complete with anchors, connections, and fasteners.
- C. Push/Pull Handles: Equip each push-up-operated or emergency-operated grille with lifting handles on each side of grille, finished to match grille.
 - 1. Provide pull-down straps or pole hooks for grilles more than 84 inches (2130 mm) high.

2.4 LOCKING DEVICES

- A. Locking Device Assembly: Fabricate with cylinder lock, spring-loaded dead bolt, operating handle, cam plate, and adjustable locking bars to engage through slots in tracks.
 - 1. Locking Bars: Both jambs, operable from both sides of curtain.
 - 2. Provide cylinder with construction core, Owner will provide final core. Comply with requirements specified in Division 08 Section "Door Hardware."

- B. Safety Interlock Switch: Equip power-operated grilles with safety interlock switch to disengage power supply when grille is locked.

2.5 COUNTERBALANCING MECHANISM

- A. General: Counterbalance grilles by means of manufacturer's standard mechanism with an adjustable-tension, steel helical torsion spring mounted around a steel shaft and contained in a spring barrel connected to top of curtain with barrel rings. Use grease-sealed bearings or self-lubricating graphite bearings for rotating members.
- B. Counterbalance Barrel: Fabricate spring barrel of manufacturer's standard hot-formed, structural-quality, welded or seamless carbon-steel pipe, of sufficient diameter and wall thickness to support rolled-up curtain without distortion of parts and to limit barrel deflection to not more than 0.03 in./ft. (2.5 mm/m) of span under full load.
- C. Spring Balance: One or more oil-tempered, heat-treated steel helical torsion springs. Size springs to counterbalance weight of curtain, with uniform adjustment accessible from outside barrel. Secure ends of springs to barrel and shaft with cast-steel barrel plugs.
- D. Torsion Rod for Counterbalance Shaft: Fabricate of manufacturer's standard cold-rolled steel, sized to hold fixed spring ends and carry torsional load.
- E. Brackets: Manufacturer's standard mounting brackets of either cast iron or cold-rolled steel plate.

2.6 ELECTRIC GRILLE OPERATORS

- A. Provide electric operators for coiling grilles where scheduled.
- B. General: Electric grille operator assembly of size and capacity recommended and provided by grille manufacturer for grille specified, with electric motor and factory-prewired motor controls, starter, gear-reduction unit, solenoid-operated brake, clutch, remote-control stations, control devices, integral gearing for locking grille, and accessories required for proper operation.
 - 1. Comply with NFPA 70.
 - 2. Provide control equipment complying with NEMA ICS 1, NEMA ICS 2, and NEMA ICS 6, with NFPA 70 Class 2 control circuit, maximum 24 V, ac or dc.
 - 3. Cycle Requirements: Maximum 20 times per day.
- C. Disconnect Device: Provide hand-operated disconnect or mechanism for automatically engaging chain and sprocket operator and releasing brake for emergency manual operation while disconnecting motor without affecting timing of limit switch. Mount disconnect and operator so they are accessible from floor level. Include interlock device to automatically prevent motor from operating when emergency operator is engaged.
- D. Design operator so motor may be removed without disturbing limit-switch adjustment and without affecting emergency auxiliary operator.

- E. Grille-Operator Type: Provide wall-, hood-, or bracket-mounted, jackshaft-type grille operator unit consisting of electric motor, enclosed lubricated gear drive, and chain and sprocket secondary drive.
- F. Electric Motors: Provide high-starting torque, reversible, continuous-duty, Class A insulated, electric motors complying with NEMA MG 1; with overload protection; sized to start, accelerate, and operate grille in either direction from any position, at not less than 6 in/sec (15 cm/s) and not more than 9 in/sec (23 cm/s), without exceeding nameplate ratings or service factor.
 - 1. Electrical Characteristics: Polyphase, 120V, 60Hz. Coordinate wiring requirements and electrical characteristics of motors with building electrical system.
 - 2. Provide motor rating (hp) as recommended by manufacturer for size and type of grille.
- G. Limit Switches: Provide adjustable switches, interlocked with motor controls and set to automatically stop grille at fully opened and fully closed positions.
- H. Remote-Control Station: Provide momentary-contact, three-button control station with push-button controls labeled "Open," "Close," and "Stop."
 - 1. Interior units, full-guarded, surface-mounted, heavy-duty type, with general-purpose NEMA ICS 6, Type 1 enclosure.
- I. Emergency Manual Operation: Equip each electrically powered grille with capability for emergency manual operation by use of disconnect cable for auxiliary push-up operation.
- J. Obstruction Detection Device: Provide each motorized grille with indicated external automatic safety sensor capable of protecting full width of grille opening. Activation of sensor immediately stops and reverses downward grille travel.
 - 1. Sensor Edge: Provide each motorized grille with an automatic safety sensor edge, located within astragal mounted to bottom bar. Contact with sensor immediately stops and reverses downward grille travel. Connect to control circuit using manufacturer's standard take-up reel or self-coiling cable.
 - a. Provide electrically actuated automatic bottom bar.

2.7 OPEN-CURTAIN GRILLE ASSEMBLY

- A. Open-Curtain Grille: Overhead coiling grille with a curtain having a network of horizontal rods that interconnect with vertical chains or spacers.
 - 1. Grille Curtain Material: Stainless steel.
 - 2. Grille Curtain Design: Straight, V3 Pattern (3" spacing)
 - a. Horizontal Rods: Solid 5/16 inch diameter stainless rods spaced 2 inches o.c. vertically

- b. Vertical Chains: Grommetted stainless steel links, 3/4 inch wide, positioned by E-rings on 3 inch centers. Provide double E-rings on horizontal bars on both sides of end chains to retain curtain in guides.
 - 3. Finish: #4 brushed finish.
 - 4. Basis-of-Design Product: Provide Visionaire Model ESG10 Straight Pattern Grille manufactured by Cornell Iron Works, Inc., or equal.
- B. Curtain Jamb Guides, Between the Jambs Mounted: Heavy duty extruded stainless steel sections with snap-on cover to conceal fasteners and polypropylene pile runners on both sides of curtain. Provide hardware as recommended by manufacturer to support grille.
 - 1. Finish: Match curtain
- C. Hood: Match curtain material and finish
 - 1. Mounting: As shown on Drawings.
- D. Locking Devices: Equip grille with locking device assembly
 - 1. Locking Device Assembly Cremone type, both jamb sides locking bars, operable from inside and outside with cylinders
- E. Grille Operator: Motorized

2.8 GENERAL FINISH REQUIREMENTS

- A. Comply with NAAMM's "Metal Finishes Manual for Architectural and Metal Products" for recommendations for applying and designating finishes.
- B. Appearance of Finished Work: Noticeable variations in same piece are not acceptable. Variations in appearance of adjoining components are acceptable if they are within the range of approved Samples and are assembled or installed to minimize contrast.

2.9 STAINLESS STEEL FINISHES

- A. Surface Preparation: Remove tool and die marks and stretch lines, or blend into finish.
- B. Polished Finishes: Grind and polish surfaces to produce uniform finish, free of cross scratches.
 - 1. Run grain of directional finishes with long dimension of each piece.
 - 2. When polishing is completed, passivate and rinse surfaces. Remove embedded foreign matter and leave surfaces chemically clean.
 - 3. Directional Satin Finish: No. 4.

PART 3 - EXECUTION

3.1 EXAMINATION

- A. Examine substrates areas and conditions, with Installer present, for compliance with requirements for substrate construction and other conditions affecting performance of the Work.
- B. Examine locations of electrical connections.
- C. Proceed with installation only after unsatisfactory conditions have been corrected.

3.2 INSTALLATION

- A. Install overhead coiling grilles and operating equipment complete with necessary hardware, anchors, inserts, hangers, and equipment supports; according to manufacturer's written instructions and as specified.
- B. Install overhead coiling grilles, hoods, and operators at the mounting locations indicated for each grille.
- C. Accessibility: Install overhead coiling grilles, switches, and controls along accessible routes in compliance with regulatory requirements for accessibility.

3.3 ADJUSTING

- A. Adjust hardware and moving parts to function smoothly so that grilles operate easily, free of warp, twist, or distortion.
- B. Lubricate bearings and sliding parts as recommended by manufacturer.

3.4 DEMONSTRATION

- A. Startup Services: Engage a factory-authorized service representative to perform startup services and to train Owner's maintenance personnel as specified below:
 - 1. Test and adjust controls and safeties. Replace damaged and malfunctioning controls and equipment.
 - 2. Train Owner's maintenance personnel on procedures and schedules related to startup and shutdown, troubleshooting, servicing, preventive maintenance, and procedures for testing and resetting release devices.
 - 3. Schedule training with Owner with at least 7 days' advance notice.

END OF SECTION 083329

SECTION 083450 - ELEVATOR DOOR SMOKE CONTAINMENT SYSTEM

PART 1 - GENERAL

1.1 SUMMARY

- A. This Section includes smoke detector activated elevator door smoke containment curtain and control system designed to provide a tight- fitting, smoke- and draft- control assembly.
- B. Related Sections include the following:
 - 1. Division 14 Section "Hydraulic Elevators" for coordination with the door opening.
 - 2. Division 26 Electrical Sections for 120v and control circuit power including conduit, boxes, conductors, wiring devices, and emergency power.
- C. Products Supplied but Not Installed under this Section:
 - 1. 10K ohm Resistor.

1.2 PERFORMANCE REQUIREMENTS

- A. Air Leakage: Less than 3 cfm (0.001416 cm/s) per sf of door opening at 0.1 in. (25 Pa) water pressure differential at ambient temperature and 400 deg. F (204 deg. C) tested per IBC 714.2.3

1.3 SUBMITTALS

- A. Product Data: For each type of product indicated.
- B. Shop Drawings: Include door width and height, jamb width, jamb and head projection, curtain width, mounting height, housing width, and motor locations. Show and identify related work performed under other Sections of these Specifications.
- C. Samples for Initial Selection: For units with factory-applied color finishes.
- D. Product Certificates: For each elevator door smoke containment system, signed by product manufacturer.
- E. Qualification Data: For Manufacturer and Installer.
- F. Product Test Reports: Based on evaluation of manufacturer's tests performed by a qualified testing agency, for each elevator door smoke containment system.
- G. Maintenance Data: For elevator door smoke containment systems to include in operation and maintenance manuals.

- H. Warranty: Special warranty specified in this Section.

1.4 QUALITY ASSURANCE

- A. Standards: Manufacturer shall maintain a quality control program in accordance with ICBO-ES Acceptance Criteria AC 77.
- B. Installer Qualifications: Manufacturer's authorized representative who is trained and approved for installation of systems for this Project.
- C. Manufacturer's Qualifications: Minimum five (5) years experience in producing smoke containment systems of the type specified.
- D. Source Limitations: Obtain all components of elevator door smoke containment system, including operators and controls, through one source from a single manufacturer.
- E. Electrical Components, Devices, and Accessories: Listed and labeled as defined in NFPA 70, Article 100.
- F. Certifications:
 - 1. Manufacturer's ICBO Evaluation Report.
 - 2. Testing Laboratory Label.
 - 3. UL Listing.

1.5 WARRANTY

- A. Special Assembly Warranty: Manufacturer's standard form in which manufacturer agrees to repair or replace components of elevator door smoke containment systems that fail in materials or workmanship within specified warranty period.
 - 1. Failure include, but are not limited to, the following:
 - a. Structural failures including, but not limited to, excessive deflection.
 - b. Faulty operation of operators and hardware.
 - c. Deterioration of metals, metal finishes, and other materials beyond normal use.
 - 2. Warranty Period: One (1) year from date of Substantial Completion.

1.6 OWNER'S INSTRUCTIONS

- A. Maintenance and Testing:
 - 1. Perform minimum semi-annual maintenance and testing on each smoke containment system as required by the manufacturer's warranty, code agency evaluation reports, and as required by local authority having jurisdiction.
 - 2. Backup Battery: Test semi-annually and replace every three (3) years.
 - 3. Retain permanent record of tests.

- B. Required Replacement: Smoke containment screen requires replacement following exposure to temperatures exceeding 200 degrees F (93 degrees C).

PART 2 - PRODUCTS

2.1 MANUFACTURERS

- A. Basis-of-Design Product: The design for the elevator door smoke containment systems is based on Model 600 manufactured by Smoke Guard Corporation. Subject to compliance with requirements, provide the named product or an approved equivalent product.

2.2 COMPONENTS

- A. Curtain:

1. Film: Minimum 1 mil (0.025 mm) thick transparent polyamide film reinforced with 100 denier nomex yarn at 0.25 in. (6.35 mm) each way.
2. Magnetic Strips: Flexible multi-pole strips attached to longitudinal edges of film with low modulus silicone adhesive.

- B. Housing: 20-gage stainless steel container and door with concealed hinges, and latch.

- C. Auxiliary Rails:

1. Material: 16-gage, ASTM A 240/240M, Type 430, ferritic stainless steel.
2. Size: 2-inch (50 mm) wide by depth required to project beyond face of elevator door frame, unless otherwise indicated.

- D. Rewind Motor: Top mount, NFPA 70, 12v DC.

- E. Release Mechanism: Comply with UL Standard No. 508 or 864.

- F. Control Station: Metal box with battery backup, power disconnect with integral circuit breaker, step down power transformer (120v AC to 12v DC), and controller circuit board.

1. Emergency Power Supply: 12v DC battery with charger.

- G. Wall Switch: Provide switch to rewind curtain into housing, system status indicators, keyed curtain deployment switch, and keyed to silence function.

1. Color: Selected by Architect from manufacturer's full range of colors.

2.3 IDENTIFICATION

- A. Label each smoke containment system with following information:

1. Manufacturer's name.
2. Maximum leakage rating at specified pressure and temperature conditions.
3. Label of quality control agency.

2.4 STAINLESS STEEL FINISHES

- A. General: Remove or blend stretch lines and tool and die marks into finish.
1. Grind and polish surfaces to produce uniform, directionally textured, polished finish indicated, free of cross scratches. Run grain with long dimension of each piece.
- B. Satin Finish: No. 4.
- C. When polishing is completed, passivate and rinse surfaces. Remove embedded foreign matter and leave surfaces chemically clean.

PART 3 - EXECUTION

3.1 EXAMINATION

- A. Examine conditions, with Installer present, for compliance with requirements for installation tolerances, supports, and other conditions affecting performance of elevator door smoke containment systems.
1. Verify related work performed under other Sections is complete and in accordance with approved Shop Drawings.
 2. Verify wall surfaces and elevator door frames are acceptable for installation of smoke containment system components.
 3. If applicable, verify existing field painted elevator door frames to be used for curtain adherence have been repainted in accordance with smoke containment system manufacturer's instructions or they have the original factory paint.
- B. Proceed with installation only after unsatisfactory conditions have been corrected.

3.2 INSTALLATION

- A. General: Do not install damaged components.
- B. Install smoke containment system components plumb, rigid, properly aligned, and securely fastened in place; comply with manufacturer's installation instructions, Contract Drawings, and approved Shop Drawings..

3.3 FIELD QUALITY CONTROL

- A. Testing Agency: Engage a qualified independent inspecting agency to perform field tests and inspections and prepare test reports. Follow manufacturer's cycle test procedures.
1. Notify Owner's Representative, local Fire Marshal, alarm sub-contractor and

- elevator service company minimum one (1) week in advance of scheduled testing.
- 2. Complete maintenance service record.

- B. Additional testing and inspecting, at Contractor's expense, will be performed to determine compliance of replaced or additional work with specified requirements.

3.4 ADJUSTING AND CLEANING

- A. Final Adjustments: Check and adjust operating hardware items just before final inspection. Leave work in complete and proper operating condition.
- B. Remove and replace defective work, including defective or damaged curtains, housings, rails, bases, and frames that are warped, bowed, or otherwise unacceptable.
- C. Clean all surfaces promptly after installation. Remove excess sealant compounds, dirt, and other substances. Repair damaged finish to match original finish.

3.5 STARTUP SERVICE

- A. Engage a factory-authorized service representative to perform startup service.
 - 1. Complete installation and startup checks according to manufacturer's written instructions.
 - 2. Test and adjust controls and safeties. Replace damaged and malfunctioning controls and equipment.
 - a. Test elevator door smoke containment system closing mechanism activated by detector or alarm-connected fire-release system. Reset elevator door smoke containment system closing mechanism after successful test.

3.6 DEMONSTRATION

- A. Engage a factory-authorized service representative to train Owner's maintenance personnel to adjust, operate, and maintain elevator door smoke containment systems.

END OF SECTION 083450

SECTION 084113 - ALUMINUM ENTRANCES AND STOREFRONTS

PART 1 - GENERAL

1.1 SUMMARY

A. This Section includes the following:

1. Exterior and interior storefront systems.
2. Exterior and interior entrance systems including manual-swing aluminum doors and door frames.
3. Operable vents, including rescue windows, installed in storefront framing system.
4. Sunshades installed in storefront framing system.

B. Related sections include the following:

1. Division 07 Section "Joint Sealants" for joint sealants installed as part of aluminum entrance and storefront systems.
2. Division 08 Section "Door Hardware."
3. Division 08 Section "Glazing."

1.2 DEFINITIONS

A. Rescue (emergency-access/egress) windows are side-hinged, single hung or sliding units that provide emergency exit

1.3 SUBMITTALS

A. Product Data: Include construction details, material descriptions, dimensions of individual components and profiles, and finishes for each type of product indicated.

B. Shop Drawings: For aluminum-framed systems. Include plans, elevations, sections, details, and attachments to other work.

1. Include structural analysis data signed and sealed by the qualified professional engineer responsible for their preparation.
2. Include details of provisions for system expansion and contraction and for draining moisture occurring within the system to the exterior.
3. For entrances, include hardware schedule and indicate operating hardware types, functions, quantities, and locations.

C. Samples for Verification: For each type of exposed finish required, in manufacturer's standard sizes.

D. Fabrication Sample: Of each vertical-to-horizontal intersection of systems, made from 12-inch (300-mm) lengths of full-size components and showing details of the following:

1. Joinery.
2. Anchorage.
3. Expansion provisions.
4. Glazing.
5. Flashing and drainage.

- E. Qualification Data: For Installer
- F. Product Test Reports: Based on evaluation of comprehensive tests performed by a qualified testing agency, for aluminum-framed systems
- G. Maintenance Data: For aluminum-framed systems to include in maintenance manuals.
- H. Warranties: Special warranties specified in this Section.

1.4 QUALITY ASSURANCE

- A. Installer Qualifications: Capable of assuming engineering responsibility and performing work of this Section and who is acceptable to manufacturer.
 1. Engineering Responsibility: Preparation of data for aluminum-framed systems including Shop Drawings based on testing and engineering analysis of manufacturer's standard units in assemblies similar to those indicated for this Project and submission of reports of tests performed on manufacturer's standard assemblies.
- B. Source Limitations: Obtain all entrance and storefront systems, curtain wall framing, aluminum doors, sunshades, and operable vent windows for the entire project through one source and from a single manufacturer.
- C. Product Options: Drawings indicate size, profiles, and dimensional requirements of entrance and storefront systems and are based on the specific systems indicated. Other manufacturers' systems with equal performance characteristics may be considered. Refer to Division 1 for substitutions.
 1. Do not modify intended aesthetic effect, as judged solely by Architect, except with Architect's approval. Where modifications are proposed, submit comprehensive explanatory data to Architect for review.
- D. Welding Standards: Comply with applicable provisions of AWS D1.2, "Structural Welding Code--Aluminum."
- E. Mockups: Prior to installing aluminum entrances and storefront system, construct mockups for each form of construction and finish required to verify selections made under Sample submittals and to demonstrate aesthetic effects as well as qualities of materials and execution. Build mockups to comply with the following requirements, using materials indicated for Work.

1. Locate mockups on-site in the location and of the size indicated or, if not indicated, as directed by Architect.
2. Include vent windows and glazing in mock-up.
3. Notify Architect 7 days in advance of the dates and times when mockups will be constructed.
4. Demonstrate the proposed range of aesthetic effects and workmanship.
5. Obtain Architect's approval of mockups before start of Work.
6. Retain and maintain mockups during construction in an undisturbed condition as a standard for judging the completed Work.
7. Approved mockups in an undisturbed condition at the time of Substantial Completion may become part of the completed Work.

F. Preinstallation Conference: Conduct conference at Project site. Review methods and procedures related to glazed aluminum curtain wall system including, but not limited to, the following:

1. Inspect and discuss condition of substrate and other preparatory work performed by other trades.
2. Review and finalize construction schedule and verify availability of materials, Installer's personnel, equipment, and facilities needed to make progress and avoid delays.
3. Review required inspecting, testing, and certifying procedures.
4. Review weather and forecasted weather conditions and procedures for coping with unfavorable conditions.
5. Review requirements for coordinating installation of aluminum entrances and storefront framing with installation of electrical wiring and electrified hardware concealed in framing members

1.5 PROJECT CONDITIONS

A. Field Measurements: Verify dimensions by field measurements before fabrication and indicate measurements on Shop Drawings. Coordinate fabrication schedule with construction progress to avoid delaying the Work.

1.6 WARRANTY

A. General Warranty: The special warranty specified in this Article shall not deprive the Owner of other rights the Owner may have under other provisions of the Contract Documents and shall be in addition to, and run concurrent with, other warranties made by the Contractor under requirements of the Contract Documents.

B. Special Warranty: Submit a written warranty executed by the manufacturer agreeing to repair or replace components of entrance and storefront systems that fail in materials or workmanship within the specified warranty period. Failures include, but are not limited to, the following:

1. Warranty Period for Framing: 3 years from date of Substantial Completion.
 - a. Structural failures including, but not limited to, excessive deflection.
 - b. Failure of system to meet performance requirements.

- c. Failure of operating components to function normally.
 - d. Water leakage through fixed glazing and frame areas.
2. Warranty Period for Finishes: 20 years from date of Substantial Completion.
 - a. Deterioration of metal finishes beyond normal weathering.
3. Warranty Period for Doors: 2 years from date of Substantial Completion.
4. Warranty Period for Operable Vents: 2 years from date of Substantial Completion.

PART 2 - PRODUCTS

2.1 PERFORMANCE REQUIREMENTS

- A. General: Provide aluminum-framed systems, including anchorage, capable of withstanding, without failure, the effects of the following:
 1. Structural loads.
 2. Thermal movements.
 3. Movements of supporting structure indicated on Drawings including, but not limited to, story drift and deflection from uniformly distributed and concentrated live loads.
 4. Dimensional tolerances of building frame and other adjacent construction.
 5. Failure includes the following:
 - a. Deflection exceeding specified limits.
 - b. Thermal stresses transferred to building structure.
 - c. Framing members transferring stresses, including those caused by thermal and structural movements, to glazing.
 - d. Noise or vibration created by wind and thermal and structural movements.
 - e. Loosening or weakening of fasteners, attachments, and other components.
 - f. Sealant failure.
 - g. Failure of operating units to function properly.
- B. Structural Loads:
 1. Wind Loads: Resist wind positive and negative pressures calculated according to International Building Code and Building Code of New York State, Section 1609:
 - a. Exterior Wind Loading Code Criteria: As indicated on Structural Drawings.
 - b. Interior Wind Loads: 5 psf
- C. Deflection of Framing Members:
 1. Deflection Normal to Wall Plane: Limited to 1/175 of clear span for spans up to 13 feet 6 inches (4.1 m) or an amount that restricts edge deflection of individual glazing lites to 3/4 inch (19 mm), whichever is less.
 2. Deflection Parallel to Glazing Plane: Limited to amount not exceeding that which reduces glazing bite to less than 75 percent of design dimension and that which reduces edge clearance between framing members and glazing or other fixed components directly below to less than 1/8 inch (3.2 mm) and clearance between members and operable units directly below to less than 1/16 inch (1.5 mm).

- D. Structural-Test Performance: Provide aluminum-framed systems tested according to ASTM E 330 as follows:
1. When tested at positive and negative wind-load design pressures, systems do not evidence deflection exceeding specified limits.
 2. When tested at 150 percent of positive and negative wind-load design pressures, systems, including anchorage, do not evidence material failures, structural distress, and permanent deformation of main framing members exceeding 0.2 percent of span.
 3. Test Durations: As required by design wind velocity but not less than 10 seconds.
- E. Thermal Movements: Provide aluminum-framed systems that allow for thermal movements resulting from the following maximum change (range) in ambient and surface temperatures. Base engineering calculation on surface temperatures of materials due to both solar heat gain and nighttime-sky heat loss.
1. Temperature Change (Range): 120 deg F (67 deg C), ambient; 180 deg F (100 deg C), material surfaces.
- F. Air Infiltration:
1. Storefront and Entrance Fixed Framing: When tested according to ASTM E 283 at a static-air-pressure difference of 6.24 lbf/sq. ft. (300 Pa) air leakage rate shall not exceed 0.06 cfm/sq. ft.
 2. Doors: When tested in accordance with ASTM E 283 at a static-air-pressure difference of 1.57 lbf/sq. ft. air leakage rate shall not exceed 1.0 cfm/lin. ft. of perimeter crack for single (3'-0" x 7'-0") door and pair of doors (6'-0" x 7'-0"),
 3. Operable Vents: When tested according to ASTM E 283 at a static-air-pressure difference of 6.24 lbf/sq. ft. (300 Pa) air leakage rate shall not exceed 0.01 cfm/sq. ft.
- G. Water Penetration Under Static Pressure:
1. Storefront and Entrance Fixed Framing: When tested according to ASTM E 331, there shall be no leakage at a static-air-pressure differential of 10 psf as defined in AAMA 501.
 2. Operable Vents: When tested according to ASTM E 331 and ASTM E547, there shall be no leakage as defined in the test method at a static-air-pressure differential of 12 psf .
- H. Condensation Resistance: When tested according to AAMA 1503 the CRF shall be not less than the following:
1. Storefront and Entrance Framing: 69 (frame) and 70 (glass).
 2. Operable Vents: 73 (frame) and 60 (glass)
 3. Doors: 49 (frame) and 68 (glass)

- I. Average Thermal Conductance: When tested according to AAMA 507 or NFRC 100 the overall U-factor (project specific) shall be no more than the following:
 - 1. Storefront and Entrance Framing: 0.37
 - 2. Operable Vents: 0.38
 - 3. Doors: 0.53
- J. Window Performance Class and Grade: Comply with requirements of AAMA/WDMA/CSA 101/I.S.2/A440 Performance Class and Grade AW-PG90-C. Window units shall successfully pass life-cycle test requirements specified in AAMA 910.

2.2 MANUFACTURERS

- A. Manufacturers: Provide specified products of Kawneer Company, Inc., an Arconic Company or equivalent products by one of the following:
 - 1. EFCO Corporation.
 - 2. YKK AP America Inc.

2.3 MATERIALS

- A. Aluminum: Alloy and temper recommended by manufacturer for type of use and finish indicated, complying with the requirements of standards indicated below.
 - 1. Sheet and Plate: ASTM B 209 (ASTM B 209M).
 - 2. Extruded Bars, Rods, Shapes, and Tubes: ASTM B 221 (ASTM B 221M).
 - 3. Extruded Structural Pipe and Tubes: ASTM B 429.
 - 4. Bars, Rods, and Wire: ASTM B 211 (ASTM B 211M).
 - 5. Welding Rods and Bare Electrodes: AWS A5.10.
- B. Steel Reinforcement: Complying with ASTM A 36 (ASTM A 36M) for structural shapes, plates, and bars; ASTM A 611 for cold-rolled sheet and strip; or ASTM A 570 (ASTM A 570M) for hot-rolled sheet and strip.
- C. Glazing as specified in Division 08 Section "Glazing."
- D. Glazing Gaskets: Manufacturer's standard pressure-glazing system of black, resilient glazing gaskets, setting blocks, and shims or spacers, fabricated from an elastomer of type and in hardness recommended by system and gasket manufacturer to comply with system performance requirements. Provide gasket assemblies that have corners sealed with sealant recommended by gasket manufacturer.
- E. Spacers, Setting Blocks, Gaskets, and Bond Breakers: Manufacturer's standard permanent, nonmigrating types in hardness recommended by manufacturer, compatible with sealants, and suitable for system performance requirements.
- F. Framing system gaskets, sealants, and joint fillers as recommended by manufacturer for joint type.

- G. Sealants and joint fillers for joints at perimeter of entrance and storefront systems as specified in Division 07 Section "Joint Sealants."
- H. Bituminous Paint: Cold-applied asphalt-mastic paint complying with SSPC-Paint 12 requirements, except containing no asbestos, formulated for 30-mil (0.762-mm) thickness per coat.
- I. Emergency Rescue Labels: 3 inch tall by 5 inch wide decal with bright yellow background, and black letters (Helvetica Medium type), with the following words: RESCUE WINDOW, centered on decal.
 - 1. Provide all designated rescue windows with a permanent decal located on the sash (centered at bottom of lower sash or window) readable from both sides.

2.4 COMPONENTS

- A. Exterior and Interior Storefront and Entrance Framing Members (4-1/2" Deep): Manufacturer's standard extruded-aluminum framing members of thickness required and reinforced as required to support imposed loads. Provide outside captured pressure-plate type framing system, center glazed.
 - 1. Thermal-Break Construction: Kawneer DUAL Isolock™ Thermal Break with two (2) 1/4" (6.4 mm) separations consisting of a two-part chemically curing, high-density polyurethane, which is mechanically and adhesively joined to aluminum storefront sections. Thermal break shall be designed in accordance with AAMA TIR-A8 and tested in accordance with AAMA 505 .
 - 2. Aluminum vertical and horizontal main frame extrusions shall have a minimum wall thickness of .070.
 - 3. Provide entrance framing members compatible with glass framing in appearance and provide single acting entrance frames with positive barrier weathering
 - 4. Provide heavy wall entrance door frames as required to support 2-1/4" heavy wall doors.
 - 5. Dimensions of Framing Members: Provide framing with vertical and horizontal framing members having a nominal face dimension of 2 inches and overall depth of 4-1/2 inches.
 - 6. Finish: Three-Coat PVDF
 - 7. Basis of Design Products: Provide Trifab 451UT by Kawneer Company, Inc., an Arconic Company or equal products of one of the following:
 - a. EFCO Corp.
 - b. Tubelite Inc.
 - 8. Location: Where indicated on the Drawings.
- B. Doors: Manufacturer's standard thermally broken glazed doors, for manual swing operation.
 - 1. Door Construction: 2-1/4 inch overall thickness, with minimum 0.125-inch- (3.2-mm-) thick, extruded-aluminum tubular rail and stile members. Mechanically fasten corners with reinforcing brackets that are deep penetration and fillet welded.

2. Thermal Break: Thermal break shall be IsoPour™ utilizing two continuous rows of polypropylene with a nominal 7/32" (5.5 mm) separation consisting of a two-part, chemically curing high density polyurethane which is mechanically and adhesively bonded to the aluminum at door rails and stiles.
 3. Glazing Stops and Gaskets: Provide manufacturer's standard snap-on extruded-aluminum glazing stops and preformed gaskets. Provide nonremovable glazing stops on outside of door. Glazing moldings shall be minimum .05" thick.
 4. Door Design: Wide stile; 5 inches wide.
 - a. Top Rail: 5 inches wide.
 - b. Mid Rail (Where indicated): 5 inches wide.
 - c. Bottom Rail: 10 inches wide
 5. Finish: Three-Coat PVDF.
 6. Basis of Design Product: Provide 500T Insulpour Thermal Entrance Doors by Kawneer Company, Inc., an Arconic Company or equal products of one of the following:
 - a. EFCO Corp.
 - b. YKK
- C. Brackets and Reinforcements: Provide manufacturer's standard brackets and reinforcements that are compatible with adjacent materials. Provide nonstaining, nonferrous shims for aligning system components.
1. Provide all required accessories (fasteners, clips, brackets, supports, etc.) required for adjustment and installation as required by field conditions.
- D. Fasteners and Accessories: Manufacturer's standard corrosion-resistant, nonstaining, nonbleeding fasteners and accessories compatible with adjacent materials.
1. Reinforce members as required to retain fastener threads.
 2. Do not use exposed fasteners, except for hardware application. For hardware application, use countersunk Phillips flat-head machine screws finished to match framing members or hardware being fastened, unless otherwise indicated.
 3. Provide all required accessories (fasteners, clips, brackets, supports, etc.) required for adjustment and installation as required by field conditions.
- E. Concrete and Masonry Inserts: Hot-dip galvanized cast-iron, malleable-iron, or steel inserts complying with ASTM A 123 or ASTM A 153 requirements.
- F. Concealed Flashing: Manufacturer's standard corrosion-resistant, nonstaining, nonbleeding flashing, compatible with adjacent materials, and of type recommended by manufacturer.
- G. Weather Stripping: Manufacturer's standard replaceable weather compression weather stripping of molded PVC complying with ASTM D 2287 requirements.
- H. Insulating Materials: Provide fiberglass batts for stuffing in openings and cracks.
- 2.5 DOOR HARDWARE

- A. General: Provide hardware units indicated below in sizes, number, and type recommended by manufacturer for entrances indicated. Finish exposed parts to match door finish, unless otherwise indicated. All hardware shall be ADA compliant.
- B. Thresholds: At exterior doors, provide manufacturer's standard thermally broken threshold with cutouts coordinated for operating hardware, with anchors and jamb clips, and not more than 1/2-inch- (12.7-mm-) high, with beveled edges providing a floor level change with a slope of not more than 1:2, and in the following material:
 - 1. Material: Aluminum, bronze or clear finish to match doors and frames.
- C. Weather Stripping: Provide manufacturer's standard replaceable components.
 - 1. Compression Type: Made of ASTM D 2000, molded neoprene, or ASTM D 2287, molded PVC.
 - 2. Sliding Type: AAMA 701, made of wool, polypropylene, or nylon woven pile with nylon-fabric or aluminum-strip backing.
- D. Weather Sweeps: Provide manufacturer's standard weather sweep for application to exterior door bottoms and with concealed fasteners on mounting strips.
- E. Remainder of hardware is specified in Section 087100.

2.6 SUNSHADE

- A. General: Projected, louvered sunshade fabricated from aluminum extrusions compatible with aluminum storefront framing system.
 - 1. Components: Square outrigger, rectangular fascia and square blades.
 - 2. Depth: As indicated on Drawings.
 - 3. Finish: Match storefront framing.
 - 4. Basis of Design Product: Versoleil SunShade by Kawneer Company, Inc., an Arconic Company or equal products of one of the following:
 - a. EFCO Corp.
 - b. Tubelite Inc.
- B. Support Design: Outrigger support bracket mechanically fastened to face of storefront framing pressure cap.

2.7 PROJECTED WINDOWS

- A. Basis of Design Product: Provide GLASSvent UT Windows, Outswing Casement by Kawneer or equal.
- B. Rescue Windows: Fabricate all window units designated as "Rescue" windows on drawings to comply with local and state codes for emergency egress windows. Provide a minimum clear opening of 6 square feet, with minimum 24" clearance for opening width and height. Rescue window maximum 54" to operating hardware.

- C. Provide outswing casement windows designed for insertion in storefront framing with minimal sightlines and interior face of the intermediate mullion in alignment and flush with storefront horizontal.
- D. Hardware: Provide the following equipment and operating hardware:
1. Hinges: Concealed stainless steel heavy-duty 4-bar friction hinges with adjustable slide shoe (2 per ventilator); *Truth Series 301*.
 2. Lock: Three Cam-action, sweep lock handles with surface-mounted strike.
 3. Limit Device: Stay bar with adjustable hold-open device.
 4. Screen Hinge: Continuous stainless steel.
 5. Screen Latch: Cast aluminum, operable from interior or exterior.
- E. Fabrication: Fabricate aluminum window units to comply with indicated standards. Include a complete system for assembly of components and anchorage of window units. Provide interior aluminum frame adapter of mitered and screw splined that is attached to the storefront framing with concealed fasteners, with tubular vent frame with screw splined corners construction, containing three sided concealed structural silicone glazed system with fourth side exposed structural glazed silicone that does not add to the exterior sightlines of the storefront framing, with bulb and fin type weather stripping that is mounted to extrusions that fits into the storefront framing glass pocket.
- F. Depth: 4-3/8 inches.
- G. Finish: Kawneer Permafluor (70% PVDF) Fluoropolymer coating meeting AAMA 2605, or equal, in Charcoal UC109852.
- H. Thermally Improved Construction: Fabricate window units with an integral, concealed, low-conductance, thermal barrier, located between exterior materials and window members exposed on interior, in a manner that eliminates direct metal-to-metal contact.
1. Provide exterior glazed units with minimal or no aluminum exposed to the exterior or poured-in-place two part polyurethane thermal-break construction that has been in use for not less than three (3) years, has been tested to demonstrate resistance to thermal conductance and condensation, and has been tested to show adequate strength and security of glass retention and compliance with the CRF indicated in Part 1, Article Performance Requirements.
 2. Weep Holes: Provide weep holes and internal passages to conduct infiltrating water to exterior. Pressure equalized each vent utilizing two rows of weather-stripping installed in specifically designed dovetail grooves in the extrusion, omit on bottom of vent to allow pressure equalization and drainage.
 3. Subframes Frames: Provide subframes with anchors for window units as shown, of profile and dimensions indicated but not less than 0.125-inch- thick extruded aluminum. Cope and screw spline corners.
 4. Vent Frames: Provide vents of tubular extrusions of profile and dimensions indicated but not less than 0.156-inch- thick extruded aluminum. Miter corners, angle reinforce, crimp cold, epoxy weld, seal and dress smooth with concealed mechanical joint fasteners.

- I. Preglazed Fabrication: Preglaze projected window units at the factory. Comply with glass and glazing requirements of Division 08 Section "Glazing" of these Specifications and AAMA 101.
 - 1. Glaze all units with four-sided structural glazed silicone. Only factory glazing of the structural silicone shall be acceptable..
 - 2. Prepare surfaces that will contact structural sealant according to sealant manufacturer's written instructions to ensure compatibility and adhesion. Preparation includes, but is not limited to, cleaning and priming surfaces.
 - 3. Install structural silicone sealant according to sealant manufacturer's written instructions.
 - 4. Mechanically fasten glazing in place until structural sealant is cured.
 - 5. Remove excess sealant from component surfaces before sealant has cured.
 - 6. Absolutely no field application of structural sealant for operable units is permitted.

- J. Insect Screens: Provide insect screens for each operable exterior ventilator. Locate screens on the inside of the window sash or ventilator. Design windows and hardware to accommodate screens in a tight-fitting removable arrangement, with a minimum of exposed fasteners and latches.
 - 1. Wickets: Provide full height screen hinged-type wickets, framed and trimmed for a tight fit and durability during handling. Provide continuous full side hinge screens. Mount continuous hinge to screen frame and window frame, so that hinge leaves are concealed, when viewed from exterior and interior. Provide appropriate size hinge leaf width to facilitate maintenance re-screening. Hinge length to be flush with top and bottom of screen frame. Provide one latch, which matches hinge finish, at mid span of each screen.
 - 2. Screen Frames: Fabricate frames of tubular-shaped extruded aluminum members of 0.040-inch minimum wall thickness, with mitered or coped joints and concealed mechanical fasteners. Finish frames to match window units.
 - a. Provide removable extruded PVC spline-anchor concealing the edge of the screen frame

2.8 FABRICATION

- A. General: Fabricate components that, when assembled, will have accurately fitted joints with ends coped or mitered to produce hairline joints free of burrs and distortion. After fabrication, clearly mark components to identify their locations in Project according to Shop Drawings.
 - 1. Fabricate components for screw-spline frame construction.

- B. Forming: Form shapes with sharp profiles, straight and free of defects or deformations, before finishing.

- C. Prepare components to receive concealed fasteners and anchor and connection devices.

- D. Fabricate components to drain water passing joints and condensation and moisture occurring or migrating within the system to the exterior.
- E. Welding: Weld components to comply with referenced AWS standard. Weld before finishing components to greatest extent possible. Weld in concealed locations to greatest extent possible to minimize distortion or discoloration of finish. Remove weld spatter and welding oxides from exposed surfaces by descaling or grinding.
- F. Glazing Channels: Provide minimum clearances for thickness and type of glass indicated according to GANA's "Glazing Manual."
- G. Metal Protection: Where aluminum will contact dissimilar metals, protect against galvanic action by painting contact surfaces with primer or by applying sealant or tape recommended by manufacturer for this purpose. Where aluminum will contact concrete or masonry, protect against corrosion by painting contact surfaces with bituminous paint.
- H. Storefront: Fabricate framing in profiles indicated. Provide subframes and reinforcing of types indicated or, if not indicated, as required for a complete system. Factory assemble components to greatest extent possible. Disassemble components only as necessary for shipment and installation.
- I. Entrances: Fabricate door framing in profiles indicated. Reinforce as required to support imposed loads. Factory assemble door and frame units and factory install hardware to greatest extent possible. Reinforce door and frame units as required for installing hardware indicated. Cut, drill, and tap for factory-installed hardware before finishing components.
 - 1. Provide compression weather stripping at fixed stops. At other locations, provide sliding weather stripping retained in adjustable strip mortised into door edge.
 - 2. At exterior door bottom rail, provide an EPDM blade gasket sweep strip applied with concealed fasteners.
 - 3. Install door hinges at factory; field apply other hardware not supplied with the door and frame assemblies.
- J. Prefabrication: Complete fabrication, assembly, finishing, hardware application, and other work to the greatest extent possible before shipment to the Project site. Disassemble components only as necessary for shipment and installation.
 - 1. Perform fabrication operations, including cutting, fitting, forming, drilling and grinding of metal work to prevent damage to exposed finish surfaces. Complete these operations for hardware prior to application of finishes.
 - 2. Do not drill and tap for surface-mounted hardware items until time of installation at project site. Refer to Division 08 Section "Door Hardware" for additional hardware installation requirements.
 - 3. Preglaze doors but do not preglaze framing system. Refer to Division 08 Section "Glazing" for specifications.
- K. Welding: Comply with AWS recommendations. Grind exposed welds smooth to remove weld spatter and welding oxides. Restore mechanical finish.

1. Welding behind finished surfaces shall be performed in such a manner as to minimize distortion and discoloration on the finished surface.
 - L. Reinforcing: Install reinforcing as required for hardware and as necessary for performance requirements, sag resistance and rigidity.
 - M. Dissimilar Metals: Separate dissimilar metals with bituminous paint, or a suitable sealant, or a nonabsorptive plastic or elastomeric tape, or a gasket between the surfaces. Do not use coatings containing lead.
 - N. Continuity: Maintain accurate relation of planes and angles with hairline fit of contacting members.
 - O. Fasteners: Conceal fasteners wherever possible.
- 2.9 ALUMINUM FINISHES
- A. General: Comply with NAAMM's "Metal Finishes Manual for Architectural and Metal Products" for recommendations relative to applying and designating finishes.
 - B. Appearance of Finished Work: Variations in appearance of abutting or adjacent pieces are acceptable if they are within one-half of the range of approved Samples. Noticeable variations in the same piece are not acceptable. Variations in appearance of other components are acceptable if they are within the range of approved Samples and are assembled or installed to minimize contrast.
 - C. Finish designations prefixed by AA conform to the system established by the Aluminum Association for designating aluminum finishes.
 - D. Superior-Performance Organic Finish, Three-Coat PVDF: Fluoropolymer finish complying with AAMA 2605 and containing not less than 70 percent PVDF resin by weight in both color coat and clear topcoat.
 1. Prepare, pretreat, and apply coating to exposed metal surfaces to comply with coating and resin manufacturers' written instructions.
 2. Color and Gloss: Kawneer Permafluor Charcoal UC109852.

PART 3 - EXECUTION

3.1 EXAMINATION

- A. Examine areas, with Installer present, for compliance with requirements for installation tolerances and other conditions affecting performance of entrance and storefront systems. Do not proceed with installation until unsatisfactory conditions have been corrected.

3.2 INSTALLATION

- A. General: Comply with manufacturer's written instructions for protecting, handling, and installing entrance and storefront systems. Do not install damaged components. Fit frame joints to produce hairline joints free of burrs and distortion. Rigidly secure nonmovement joints. Seal joints watertight.
- B. Metal Protection: Where aluminum will contact dissimilar metals, protect against galvanic action by painting contact surfaces with primer or by applying sealant or tape recommended by manufacturer for this purpose. Where aluminum will contact concrete or masonry, protect against corrosion by painting contact surfaces with bituminous paint.
- C. Install components to drain water passing joints and condensation and moisture occurring or migrating within the system to the exterior.
- D. Set continuous sill members and flashing in a full sealant bed to provide weathertight construction, unless otherwise indicated. Comply with requirements of Division 7 Section "Joint Sealants."
 - 1. Install sill flashings with allowance for expansion and contraction at 12 feet on center. Seal expansion joint with manufacturer's recommended pliable sealing tape.
- E. Install framing components plumb and true in alignment with established lines and grades without warp or rack of framing members.
- F. Install entrances plumb and true in alignment with established lines and grades without warp or rack. Lubricate operating hardware and other moving parts according to hardware manufacturers' written instructions.
 - 1. Install surface-mounted hardware according to manufacturer's written instructions using concealed fasteners to greatest extent possible.
- G. Install glazing to comply with requirements of Division 08 Section "Glazing," unless otherwise indicated.
- H. Install windows in storefront framing in compliance with manufacturer's directions and approved shop drawings.
- I. Install sunshade in storefront framing in compliance with manufacturer's directions and approved shop drawings.
- J. Install perimeter sealant to comply with requirements of Division 07 Section "Joint Sealants," unless otherwise indicated.
- K. Install insulation materials in locations indicated, and at head and jamb of storefront system stuffed into openings, held above sill 1 inch (25 mm).
- L. Erection Tolerances: Install entrance and storefront systems to comply with the following maximum tolerances:

1. Variation from Plane: Limit variation from plane or location shown to 1/8 inch in 12 feet (3 mm in 3.7 m); 1/4 inch (6 mm) over total length.
2. Alignment: Where surfaces abut in line, limit offset from true alignment to 1/16 inch (1.5 mm). Where surfaces meet at corners, limit offset from true alignment to 1/32 inch (0.8 mm).
3. Diagonal Measurements: Limit difference between diagonal measurements to 1/8 inch (3 mm).

3.3 ADJUSTING AND CLEANING

- A. Adjust doors and hardware to provide tight fit at contact points and weather stripping, smooth operation, and weathertight closure.
- B. Remove excess sealant and glazing compounds, and dirt from surfaces.

3.4 PROTECTION

- A. Provide final protection and maintain conditions, in a manner acceptable to manufacturer and Installer, that ensure entrance and storefront systems are without damage or deterioration at the time of Substantial Completion.

3.5 HARDWARE SCHEDULE - Refer to Section 087100

END OF SECTION 084113

The following additions, substitutions, or clarifications are extracted from the (5) Bid Addenda issued with this project during bidding. This insert is intended to summarize addendum information relevant to this specification section. See Bid Addenda issued by the City of Yonkers for complete contract document changes.

Bid Addendum No. 4:

Modifications to specified U-Value for NanaWall:

H. Average Thermal Conductance: Provide aluminum-framed systems with fixed glazing and framing areas having average U-factor of not more than 0.36 when tested according to AAMA 1503.

SECTION 084133 - FOLDING GLASS STOREFRONTS

PART 1 - GENERAL

1.1 SUMMARY

A. This Section includes the following:

1. Exterior folding glass storefront system.

B. Related sections include the following:

1. Division 07 Section "Joint Sealants" for joint sealants installed as part of aluminum entrance and storefront systems.
2. Division 08 Section "Door Hardware."
3. Division 08 Section "Glazing."

1.2 PERFORMANCE REQUIREMENTS

A. General: Provide aluminum-framed systems, including anchorage, capable of withstanding, without failure, the effects of the following:

1. Structural loads.
2. Thermal movements.
3. Movements of supporting structure indicated on Drawings including, but not limited to, story drift and deflection from uniformly distributed and concentrated live loads.
4. Dimensional tolerances of building frame and other adjacent construction.
5. Failure includes the following:
 - a. Deflection exceeding specified limits.
 - b. Thermal stresses transferred to building structure.
 - c. Framing members transferring stresses, including those caused by thermal and structural movements, to glazing.
 - d. Noise or vibration created by wind and thermal and structural movements.
 - e. Loosening or weakening of fasteners, attachments, and other components.
 - f. Sealant failure.
 - g. Failure of operating units to function properly.

B. Structural Loads:

1. Wind Loads: Resist wind positive and negative pressures calculated according to International Building Code and Building Code of New York:
 - a. Exterior Wind Loading Code Criteria: As indicated on Drawings.

C. Deflection of Framing Members:

1. Deflection Normal to Wall Plane: Limited to 1/175 of clear span for spans up to 13 feet 6 inches (4.1 m) or an amount that restricts edge deflection of individual glazing lites to 3/4 inch (19 mm), whichever is less.
 2. Deflection Parallel to Glazing Plane: Limited to amount not exceeding that which reduces glazing bite to less than 75 percent of design dimension and that which reduces edge clearance between framing members and glazing or other fixed components directly below to less than 1/8 inch (3.2 mm) and clearance between members and operable units directly below to less than 1/16 inch (1.5 mm).
- D. Structural-Test Performance: Provide aluminum-framed systems tested according to ASTM E 330 as follows:
1. When tested at positive and negative wind-load design pressures, systems do not evidence deflection exceeding specified limits.
 2. When tested at 150 percent of positive and negative wind-load design pressures, systems, including anchorage, do not evidence material failures, structural distress, and permanent deformation of main framing members exceeding 0.2 percent of span.
 3. Test Durations: As required by design wind velocity but not less than 10 seconds.
- E. Thermal Movements: Provide aluminum-framed systems that allow for thermal movements resulting from the following maximum change (range) in ambient and surface temperatures. Base engineering calculation on surface temperatures of materials due to both solar heat gain and nighttime-sky heat loss.
1. Temperature Change (Range): 120 deg F, ambient; 180 deg F, material surfaces.
- F. Air Infiltration: Provide aluminum-framed systems with maximum air leakage through fixed glazing and framing areas of 0.29 cfm/sq. ft. of fixed wall area when tested according to ASTM E 283 at a minimum static-air-pressure difference of 6.24 lbf/sq. ft.
- G. Water Penetration Under Static Pressure: Provide aluminum-framed systems that do not evidence water penetration through fixed glazing and framing areas when tested according to ASTM E 331 at a minimum static-air-pressure difference of 5.5 psf for insulating glass framing.
1. Maximum Water Leakage: No uncontrolled water penetrating systems or appearing on systems' normally exposed interior surfaces from sources other than condensation. Water controlled by flashing and gutters that is drained to exterior and cannot damage adjacent materials or finishes is not considered water leakage.
- H. Average Thermal Conductance: Provide aluminum-framed systems with fixed glazing and framing areas having average U-factor of not more than 0.30 when tested according to AAMA 1503.
- I. Glass Acoustical Performance: System STC 33 and OITC 27 with 15/16 inch double IGU, 4mm and 4mm STC 32 tempered glass.

1.3 SUBMITTALS

- A. Product Data: Include construction details, material descriptions, dimensions of individual components and profiles, and finishes for each type of product indicated.
- B. Shop Drawings: For aluminum-framed systems. Include plans, elevations, sections, details, and attachments to other work.
 - 1. Include structural analysis data signed and sealed by the qualified professional engineer responsible for their preparation.
 - 2. Include details of provisions for system expansion and contraction and for draining moisture occurring within the system to the exterior.
 - 3. For entrances, include hardware schedule and indicate operating hardware types, functions, quantities, and locations.
- C. Samples for Verification: For each type of exposed finish required, in manufacturer's standard sizes.
- D. Fabrication Sample: Of each vertical-to-horizontal intersection of systems, made from 12-inch (300-mm) lengths of full-size components and showing details of the following:
 - 1. Joinery.
 - 2. Anchorage.
 - 3. Expansion provisions.
 - 4. Glazing.
 - 5. Flashing and drainage.
- E. Qualification Data: For Installer
- F. Product Test Reports: Based on evaluation of comprehensive tests performed by a qualified testing agency, for aluminum-framed systems
- G. Maintenance Data: For aluminum-framed systems to include in maintenance manuals.
- H. Warranties: Special warranties specified in this Section.

1.4 QUALITY ASSURANCE

- A. Installer Qualifications: Capable of assuming engineering responsibility and performing work of this Section and who is acceptable to manufacturer.
 - 1. Engineering Responsibility: Preparation of data for aluminum-framed systems including Shop Drawings based on testing and engineering analysis of manufacturer's standard units in assemblies similar to those indicated for this Project and submission of reports of tests performed on manufacturer's standard assemblies.
- B. Product Options: Drawings indicate size, profiles, and dimensional requirements of entrance and storefront systems and are based on the specific systems indicated. Other

manufacturers' systems with equal performance characteristics may be considered. Refer to Division 01 for substitutions.

1. Do not modify intended aesthetic effect, as judged solely by Architect, except with Architect's approval. Where modifications are proposed, submit comprehensive explanatory data to Architect for review.

1.5 PROJECT CONDITIONS

- A. Field Measurements: Verify dimensions by field measurements before fabrication and indicate measurements on Shop Drawings. Coordinate fabrication schedule with construction progress to avoid delaying the Work.

1.6 WARRANTY

- A. Special Warranty: Manufacturer's standard form in which manufacturer agrees to repair or replace components of glass panel panel partitions that fail in materials or workmanship within specified warranty period.
 1. Failures include, but are not limited to, the following:
 - a. Faulty operation of glass panel panel partitions.
 - b. Deterioration of glazing, metals, metal finishes, and other materials beyond normal wear.
 2. Warranty Period: Ten years from date of Substantial Completion.

PART 2 - PRODUCTS

2.1 PRODUCTS AND MANUFACTURERS

- A. Basis of Design Product: Provide NanaWall SL70 by Nana Wall Systems, Inc., or equal.

2.2 MATERIALS

- A. Aluminum: Alloy and temper recommended by manufacturer for type of use and finish indicated, complying with the requirements of standards indicated below.
 1. Sheet and Plate: ASTM B 209 (ASTM B 209M).
 2. Extruded Bars, Rods, Shapes, and Tubes: ASTM B 221 (ASTM B 221M).
 3. Extruded Structural Pipe and Tubes: ASTM B 429.
 4. Bars, Rods, and Wire: ASTM B 211 (ASTM B 211M).
 5. Welding Rods and Bare Electrodes: AWS A5.10.
- B. Steel Reinforcement: Complying with ASTM A 36 (ASTM A 36M) for structural shapes, plates, and bars; ASTM A 611 for cold-rolled sheet and strip; or ASTM A 570 (ASTM A 570M) for hot-rolled sheet and strip.

- C. Glazing: Fully tempered safety glazing meeting ANSI Z97.1 and CPSC 16CFR 1201, total 15/16" thick double IGU, lowE coated, and argon filled; refer to Division 08 Section "Glazing" for specifications.
- D. Glazing Gaskets: Manufacturer's standard pressure-glazing system of black, resilient glazing gaskets, setting blocks, and shims or spacers, fabricated from an elastomer of type and in hardness recommended by system and gasket manufacturer to comply with system performance requirements. Provide gasket assemblies that have corners sealed with sealant recommended by gasket manufacturer.
- E. Spacers, Setting Blocks, Gaskets, and Bond Breakers: Manufacturer's standard permanent, nonmigrating types in hardness recommended by manufacturer, compatible with sealants, and suitable for system performance requirements.
- F. Framing system gaskets, sealants, and joint fillers as recommended by manufacturer for joint type.
- G. Sealants and joint fillers for joints at perimeter of entrance and storefront systems as specified in Division 07 Section "Joint Sealants."
- H. Bituminous Paint: Cold-applied asphalt-mastic paint complying with SSPC-Paint 12 requirements, except containing no asbestos, formulated for 30-mil (0.762-mm) thickness per coat.

2.3 COMPONENTS

- A. Monumental Thermally Broken Aluminum Framed Folding Glass Storefront Description: Floor-track supported designed for angle changes, segmented curves. Manufacturer's standard or post reinforced frame and panel profiles, with top track, side jambs and panels with dimensions as shown on Drawings.
 - 1. Panels: Single lite.
 - 2. Rail Depth: 2-3/4 inches
 - 3. Top Rail and Stile Width: 2-1/4 inches
 - 4. Bottom Rail Width: 2-1/4 inch except 10" at swinging.
 - 5. Frame: Matching top track and side jambs
 - a. Top Track and Side Jambs Width: 2-9/16 inch
 - b. Top Track and Side Jambs Depth: 3-1/8 inch (80 mm)
 - 6. Sill: Low profile saddle sill (thermally broken) in clear anodized finish.
 - a. Provide gasket to cover the channel in the sill at swing doors for ADA compliance.
 - 7. Thickness of Aluminum Extrusions: 0.078 inch.
 - 8. Thermal-Break Construction: 3/4 to 15/16 inch wide polyamide plastic reinforced with glass fibers. Thinner or poured and de-bridged type thermal breaks not acceptable .
 - 9. System Configuration: Inward folding, 3 panels, with one outswing door.
 - 10. Panel Size: As indicated on Drawings

- B. Sliding/Folding Hardware: Provide manufacturer's standard combination sliding and folding hardware with top and bottom tracks and threshold. All running carriages to be with sealed, self-lubrication, ball bearing multi-rollers. Surface mounted hinges and running carriages not acceptable.
1. Lower Running Carriage Carrying Capacity: 440 lbs. (200 kgs)
 2. Upper guide carriage and lower running carriage provided with four vertical stainless-steel wheels and two horizontal polyamide wheels.
 3. Vertical wheels to ride on top of stainless-steel guide track covers over the full length of the sill track and lie above the water run-off level.
 4. Swing Panel Hinges: Zinc die cast with finish closest match to finish of frame and panels and stainless-steel security hinge pins with set-screws.
 5. Adjustment: Provide folding-sliding hardware capable of compensation and adjustments without needing to remove panels from tracks, in width, 1/16 inch (1.5 mm) per hinge and in height, 5/64 inch (2 mm) up and down.
- C. Weatherstripping: Manufacturer's double layer EPDM between panels, EPDM gasket and Q-lon gasket, or brush seal between panel and frame, or brush seals with a two-layer fiberglass reinforced polyamide fin attached at both inner and outer edge of bottom of door panels with a recessed sill or on frame for sealing between panels and between panel and frame.
- D. Locking Hardware and Handles:
1. Main Entry Panel(s) for Models WITH a Swing Panel: Provide manufacturer's standard lever handles on the inside and outside, and a lockset with a lockable latch, and multi-point locking with a dead bolt and rods at the top and bottom on primary panel.
 - a. Rods to be concealed and not edge mounted.
 - b. After turn of key or thumbturn, depression of handles withdraws latch.
 - c. Lifting of handles engages rods and turn of key or thumb turn engages deadbolt and operates lock.
 - d. Lever handle in brushed stainless steel finish.
 - e. Locking: Cylinder with adapter for interchangeable core, compatible with Owner's system.
 - f. Provide a panic device on the interior side of the door.
 2. Secondary Panels and Pairs of Folding Panels: Provide manufacturer's flat handles and concealed one or two-point locking hardware operated by 180° turn of handle between each pair. Face applied flush bolt locking not acceptable.
 - a. Flat handle in brushed stainless steel finish.
 3. Handle Height: 41-3/8 inch (105 cm) centered from bottom of panel or as otherwise indicated.
 4. Aluminum locking rods with standard fiberglass reinforced polyamide end caps at the top and bottom. Rods to have a stroke of 15/16 inch (24 mm).
 5. Additional profile cylinders to be keyed alike.

- E. Fasteners: Tapered pins or stainless steel screws for connecting frame components.
- F. Concrete and Masonry Inserts: Hot-dip galvanized cast-iron, malleable-iron, or steel inserts complying with ASTM A 123 or ASTM A 153 requirements.
- G. Concealed Flashing: Manufacturer's standard corrosion-resistant, nonstaining, nonbleeding flashing, compatible with adjacent materials, and of type recommended by manufacturer.
- H. Insulating Materials: Provide fiberglass batts for stuffing in openings and cracks.

2.4 FABRICATION

- A. Folding Glass Wall: Extruded aluminum frame and panel profiles, corner connectors and hinges, sliding and folding hardware, locking hardware and handles, glass and glazing and weatherstripping components needed to construct a folding glass wall.
 - 1. Each unit factory pre-assembled and shipped with complete system components and installation instructions.
 - 2. Exposed work to be carefully matched to produce continuity of line and design with all joints.
 - 3. No raw edges visible at joints
- B. Fabricate components to drain water passing joints and condensation and moisture occurring or migrating within the system to the exterior.
- C. Welding: Weld components to comply with referenced AWS standard. Weld before finishing components to greatest extent possible. Weld in concealed locations to greatest extent possible to minimize distortion or discoloration of finish. Remove weld spatter and welding oxides from exposed surfaces by descaling or grinding.
- D. Glazing Channels: Provide minimum clearances for thickness and type of glass indicated according to GANA's "Glazing Manual."
- E. Metal Protection: Where aluminum will contact dissimilar metals, protect against galvanic action by painting contact surfaces with primer or by applying sealant or tape recommended by manufacturer for this purpose. Where aluminum will contact concrete or masonry, protect against corrosion by painting contact surfaces with bituminous paint.

2.5 ALUMINUM FINISHES

- A. General: Comply with NAAMM's "Metal Finishes Manual for Architectural and Metal Products" for recommendations relative to applying and designating finishes.
- B. Appearance of Finished Work: Variations in appearance of abutting or adjacent pieces are acceptable if they are within one-half of the range of approved Samples. Noticeable variations in the same piece are not acceptable. Variations in appearance of other components are acceptable if they are within the range of approved Samples and are assembled or installed to minimize contrast.

- C. Finish designations prefixed by AA conform to the system established by the Aluminum Association for designating aluminum finishes
- D. Superior-Performance Organic Finish, Three-Coat PVDF: Fluoropolymer finish complying with AAMA 2605 and containing not less than 70 percent PVDF resin by weight in both color coat and clear topcoat.
 - 1. Prepare, pretreat, and apply coating to exposed metal surfaces to comply with coating and resin manufacturers' written instructions.
 - 2. Color and Gloss: Kawneer Permafluor Charcoal UC109852.

PART 3 - EXECUTION

3.1 EXAMINATION

- A. Examine areas, with Installer present, for compliance with requirements for installation tolerances and other conditions affecting performance of entrance and storefront systems. Do not proceed with installation until unsatisfactory conditions have been corrected.

3.2 INSTALLATION

- A. General: Comply with manufacturer's written instructions for protecting, handling, and installing entrance and storefront systems. Do not install damaged components. Fit frame joints to produce hairline joints free of burrs and distortion. Rigidly secure nonmovement joints. Seal joints watertight.
- B. Metal Protection: Where aluminum will contact dissimilar metals, protect against galvanic action by painting contact surfaces with primer or by applying sealant or tape recommended by manufacturer for this purpose. Where aluminum will contact concrete or masonry, protect against corrosion by painting contact surfaces with bituminous paint.
- C. Install components to drain water passing joints and condensation and moisture occurring or migrating within the system to the exterior.
- D. Set continuous sill members and flashing in a full sealant bed to provide weathertight construction, unless otherwise indicated. Comply with requirements of Division 07 Section "Joint Sealants."
 - 1. Install sill flashings with allowance for expansion and contraction at 12 feet on center. Seal expansion joint with manufacturer's recommended pliable sealing tape.
- E. Install framing components plumb and true in alignment with established lines and grades without warp or rack of framing members.
- F. Lubricate operating hardware and other moving parts according to manufacturers' written instructions.

1. Install surface-mounted hardware according to manufacturer's written instructions using concealed fasteners to greatest extent possible.
- G. Install perimeter sealant to comply with requirements of Division 07 Section "Joint Sealants," unless otherwise indicated.
- H. Install insulation materials in locations indicated, and at head and jamb of storefront system stuffed into openings, held above sill 1 inch (25 mm).
- I. Erection Tolerances: Install entrance and storefront systems to comply with the following maximum tolerances:
 1. Variation from Plane: Limit variation from plane or location shown to 1/8 inch in 12 feet (3 mm in 3.7 m); 1/4 inch (6 mm) over total length.
 2. Alignment: Where surfaces abut in line, limit offset from true alignment to 1/16 inch (1.5 mm). Where surfaces meet at corners, limit offset from true alignment to 1/32 inch (0.8 mm).
 3. Diagonal Measurements: Limit difference between diagonal measurements to 1/8 inch (3 mm).

3.3 ADJUSTING AND CLEANING

- A. Adjust doors and hardware to provide tight fit at contact points and weather stripping, smooth operation, and weathertight closure.
- B. Remove excess sealant and glazing compounds, and dirt from surfaces.

3.4 PROTECTION

- A. Provide final protection and maintain conditions, in a manner acceptable to manufacturer and Installer, that ensure entrance and storefront systems are without damage or deterioration at the time of Substantial Completion.

END OF SECTION 084133

SECTION 084413 - GLAZED ALUMINUM CURTAIN WALLS

PART 1 - GENERAL

1.1 SUMMARY

- A. This Section includes the following:
 - 1. Glazed aluminum curtain wall, captured 4 sides.
 - 2. Operable vents, including rescue windows, installed in curtainwall framing system.
- B. Related Sections: The following Sections contain requirements that relate to this Section:
 - 1. Division 07 Section "Joint Sealants" for joint sealants installed as part of glazed aluminum curtain wall system.
 - 2. Division 08 Section "Glazing."

1.2 DEFINITIONS

- A. Rescue (emergency-access/egress) windows are side-hinged, single hung or sliding units that provide emergency exit

1.3 ACTION SUBMITTALS

- A. Product Data for each product specified, including details of construction relative to materials, dimensions of individual components, profiles, and finishes.
- B. Shop Drawings prepared by or under the supervision of a qualified professional engineer detailing fabrication and assembly of glazed aluminum curtain-wall systems.
 - 1. Show connection to and continuity with adjacent thermal, weather, air, and vapor barriers.
 - 2. Include details of provisions for assembly expansion and contraction and for draining moisture occurring within the assembly to the exterior.
- C. Delegated-Design Submittal: For glazed aluminum curtain walls, including analysis data signed and sealed by the qualified professional engineer responsible for their preparation.
- D. Cutaway Sample of each vertical-to-horizontal intersection of system, made from 12-inch (300-mm) lengths of full-size components and showing details of the following:
 - 1. Joinery.
 - 2. Anchorage.
 - 3. Expansion provisions.
 - 4. Glazing.
 - 5. Flashing and drainage.

1.4 INFORMATIONAL SUBMITTALS

A. Qualification Data:

1. For Installer.
2. For professional engineer's experience with providing delegated-design engineering services of the kind indicated, including documentation that engineer is licensed in the state in which Project is located.

B. Energy Performance Certificates: For glazed aluminum curtain walls, accessories, and components from manufacturer.

1. Basis for Certification: NFRC-certified energy performance values for each glazed aluminum curtain wall.

C. Product test reports from a qualified independent testing agency evidencing compliance of glazed aluminum curtain wall system with requirements based on comprehensive testing of manufacturer's current system.

D. Quality-Control Program: Developed specifically for Project, including fabrication and installation, in accordance with recommendations in ASTM C1401. Include periodic quality-control reports.

E. Sample Warranties: For special warranties.

1.5 CLOSEOUT SUBMITTALS

A. Maintenance Data: For glazed aluminum curtain walls to include in maintenance manuals.

1.6 QUALITY ASSURANCE

A. Professional Engineer Qualifications: A professional engineer who is legally qualified to practice in the jurisdiction where Project is located and who is experienced in providing engineering services of the kind indicated. Engineering services are defined as those performed for installations of glazed aluminum curtain wall systems that are similar to those indicated for this Project in material, design, and extent.

B. Installer Qualifications: An entity that employs installers and supervisors who are trained and approved by manufacturer.

C. Source Limitations: Obtain glazed aluminum curtain wall system, aluminum-framed entrances and storefronts, glass vent windows, and aluminum-framed entrance doors and framing from one source and by a single manufacturer for the Project.

D. Welding Standards: Comply with applicable provisions of AWS D1.2, "Structural Welding Code--Aluminum."

1. Engage welders who have satisfactorily passed AWS qualification tests for welding processes involved and who are currently certified for these processes.
- E. Mockups: Prior to installing glazed aluminum curtain wall system, construct mockups for each form of construction and finish required to verify selections made under Sample submittals and to demonstrate aesthetic effects as well as qualities of materials and execution. Build mockups to comply with the following requirements, using materials indicated for Work.
1. Locate mockups on-site in the location and of the size indicated or, if not indicated, as directed by Architect.
 2. Include operable vents and glazing in mock-up.
 3. Notify Architect 7 days in advance of the dates and times when mockups will be constructed.
 4. Demonstrate the proposed range of aesthetic effects and workmanship.
 5. Obtain Architect's approval of mockups before start of Work.
 6. Retain and maintain mockups during construction in an undisturbed condition as a standard for judging the completed Work.
 7. Approved mockups in an undisturbed condition at the time of Substantial Completion may become part of the completed Work.
- F. Preinstallation Conference: Conduct conference at Project site. Review methods and procedures related to glazed aluminum curtain wall system including, but not limited to, the following:
1. Inspect and discuss condition of substrate and other preparatory work performed by other trades.
 2. Review structural loading limitations.
 3. Review and finalize construction schedule and verify availability of materials, Installer's personnel, equipment, and facilities needed to make progress and avoid delays.
 4. Review required inspecting, testing, and certifying procedures.
 5. Review weather and forecasted weather conditions and procedures for coping with unfavorable conditions.
 6. Review requirements for coordinating installation of curtainwall framing with installation of electrical wiring and electrified hardware concealed in framing members
- 1.7 PROJECT CONDITIONS
- A. Field Measurements: Verify dimensions by field measurements before fabrication and show recorded measurements on Shop Drawings. Coordinate fabrication schedule with construction progress to avoid delaying the Work.
1. Where field measurements cannot be made without delaying the Work, guarantee dimensions and proceed with fabrication without field measurements. Coordinate construction to ensure that actual dimensions correspond to guaranteed dimensions.

1.8 WARRANTY

- A. General Warranty: The special warranty specified in this Article shall not deprive the Owner of other rights the Owner may have under other provisions of the Contract Documents and shall be in addition to, and run concurrent with, other warranties made by the Contractor under requirements of the Contract Documents.
- B. Special Warranty: Submit a written warranty executed by the manufacturer agreeing to repair or replace components of a glazed aluminum curtain wall system that fail in materials or workmanship within the specified warranty period. Failures include, but are not limited to, the following:
 - 1. Warranty Period: 10 years from date of Substantial Completion for:
 - a. Structural failures including, but not limited to, excessive deflection.
 - b. Failure of system to meet specified performance requirements.
 - c. Failure of operating components to function normally.
 - d. Water leakage through fixed glazing and frame areas.
 - e. Sealant failure.
 - f. Excessive noise or vibration of system
 - 2. Warranty Period: 20 years from date of Substantial Completion.
 - a. Deterioration of metal finishes beyond normal weathering.
 - 3. Warranty Period for Operable Vents: 2 years from date of Substantial Completion.

PART 2 - PRODUCTS

2.1 PERFORMANCE REQUIREMENTS

- A. Delegated Design: Engage a qualified professional engineer, as defined in "Quality Assurance" Article above, to design glazed aluminum curtain walls.
- B. General Performance: Comply with performance requirements specified, as determined by testing of glazed aluminum curtain walls representing those indicated for this Project without failure due to defective manufacture, fabrication, installation, or other defects in construction.
 - 1. Glazed aluminum curtain walls shall withstand movements of supporting structure, including, but not limited to, story drift, twist, column shortening, long-term creep, and deflection from uniformly distributed and concentrated live loads.
 - 2. Glazed aluminum curtain wall system, including anchorage, shall accommodate dimensional tolerances of building frame and other adjacent construction.
 - 3. Failure also includes the following:
 - a. Thermal stresses transferring to building structure.
 - b. Glass breakage.
 - c. Noise or vibration created by wind and thermal and structural movements.

- d. Loosening or weakening of fasteners, attachments, and other components.
- e. Failure of operating units.
- f. Sealant failure.

C. Structural Loads:

1. Wind Loads: As indicated on Structural Drawings.
2. Other Design Loads: As indicated on Structural Drawings

D. Deflection of Framing Members:

1. Deflection Normal to Wall Plane: Limited to 1/175 of clear span for spans of up to 13 feet 6 inches (4.1 m) and to 1/240 of clear span plus 1/4 inch (6.35 mm) for spans of greater than 13 feet 6 inches (4.1 m) or an amount that restricts edge deflection of individual glazing lites to 3/4 inch (19.1 mm), whichever is less or 3/4 inches (19 mm), whichever is smaller, unless otherwise indicated.
2. Deflection Parallel to Glazing Plane: Limited to 1/360 of clear span or 1/8 inch (3.2 mm), whichever is smaller.

E. Structural: Test in accordance with ASTM E330/E330M as follows:

1. When tested at positive and negative wind-load design pressures, assemblies do not evidence deflection exceeding specified limits.
2. When tested at 150 percent of positive and negative wind-load design pressures, assemblies, including anchorage, do not evidence material failures, structural distress, or permanent deformation of main framing members exceeding 0.2 percent of span.
3. Duration: As required by design wind velocity, but not less than 10 seconds.

F. Air Infiltration: Provide glazed aluminum curtain wall system with permanent resistance to air leakage through system of not more than 0.06 cfm/sq. ft. (0.3 L/s/sq. m) of fixed wall area when tested according to ASTM E 283 at a static-air-pressure difference of 6.2 lbf/sq. ft. (300 Pa).

1. Operable Vents: When tested according to ASTM E 283 at a static-air-pressure difference of 6.24 lbf/sq. ft. (300 Pa) air leakage rate shall not exceed 0.01 cfm/sq. ft.

G. Water Penetration under Static Pressure: Test in accordance with ASTM E331 as follows:

1. No evidence of water penetration through fixed glazing and framing areas when tested in accordance with a minimum static-air-pressure differential of 20 percent of positive wind-load design pressure, but not less than 12 lbf/sq. ft. (20 psf for triple glazed curtainwall)

H. Thermal Movements: Provide glazed aluminum curtain wall system, including anchorage, that accommodates thermal movements of system and supporting elements resulting from the following maximum change (range) in ambient and surface temperatures without

buckling, damaging stresses on glazing, failure of joint sealants, damaging loads on fasteners, noise or vibration, and other detrimental effects.

1. Temperature Change (Range): 120 deg F (67 deg C), ambient; 180 deg F (100 deg C), material surfaces.
- I. Condensation Resistance: Provide condensation-resistance factor (CRF) of not less than the amounts indicated below when tested according to AAMA 1503.1.
 1. Aluminum Curtain Wall System: 75 (framing) and 72 (glass.).
 2. Aluminum Curtainwall System with Triple Glazing: 80 (framing) and 80 (glass)
 3. Operable Vents: 73 (frame) and 60 (glass)
- J. Average Thermal Conductance: When tested according to AAMA 507 or NFRC 100 the overall U-factor (project specific) shall be no more than the following:
 1. Aluminum Curtain Wall System: 0.36
 2. Aluminum Curtainwall System with Triple Glazing: 0.24
 3. Operable Vents: 0.38
- K. Window Performance Class and Grade: Comply with requirements of AAMA/WDMA/CSA 101/I.S.2/A440 Performance Class and Grade AW-PG90-C. Window units shall successfully pass life-cycle test requirements specified in AAMA 910.

2.2 MANUFACTURERS

- A. Manufacturers: Provide specified products of Kawneer Company, Inc., an Arconic Company or equivalent products by one of the following:
 1. EFCO Corporation
 2. YKK AP America Inc.

2.3 MATERIALS

- A. Aluminum: Alloy and temper recommended by manufacturer for type of use and finish indicated, complying with the requirements of standards indicated below.
 1. Sheet and Plate: ASTM B 209 (ASTM B 209M).
 2. Extruded Bars, Rods, Shapes, and Tubes: ASTM B 221 (ASTM B 221M).
 3. Extruded Structural Pipe and Tubes: ASTM B 429.
- B. Steel Reinforcement: ASTM A 36 (ASTM A 36M) for structural shapes, plates, and bars; ASTM A 611 for cold-rolled sheet and strip; or ASTM A 570 (ASTM A 570M) for hot-rolled sheet and strip.
- C. Glazing as specified in Division 08 Section "Glazing."

- D. Glazing Gaskets: EPDM sealed-corner pressure-glazing system of black, resilient elastomeric glazing gaskets, setting blocks, and shims or spacers; in hardness recommended by manufacturer.
- E. Glazing sealants and fillers as specified in Division 08 Section "Glazing."
- F. Framing system gaskets and joint fillers as recommended by manufacturer for joint type.
- G. Sealants and joint fillers for joints within glazed aluminum curtain wall system as specified in Division 07 Section "Joint Sealants."
- H. Firestop materials as specified in Division 07 Section "Fire-Resistive Joint Systems."
- I. Insulating Materials: Provide fiberglass batts for stuffing in openings and cracks as specified in Division 07 Section "Thermal Insulation."
- J. Weather Stripping: Manufacturer's standard replaceable weather compression weather stripping of molded PVC complying with ASTM D 2287 requirements.
- K. Bituminous Paint: Cold-applied asphalt-mastic paint complying with SSPC-Paint 12 requirements, except containing no asbestos, formulated for 30-mil (0.762-mm) thickness per coat.
- L. Emergency Rescue Labels: 3 inch tall by 5 inch wide decal with bright yellow background, and black letters (Helvetica Medium type), with the following words: RESCUE WINDOW, centered on decal.
 - 1. Provide all designated rescue windows with a permanent decal located on the sash (centered at bottom of lower sash or window) readable from both sides.

2.4 COMPONENTS

- A. Curtain Wall System: Manufacturer's standard extruded-aluminum framing members for multi-story curtainwall application of thickness required and reinforced as required to support imposed loads. Provide outside glazed system, with pressure plate, captured horizontal and vertical mullions.
 - 1. Provide mullion configuration with pockets at the inside glazing face to receive fixed resilient elastomeric glazing seal; flexible silicone-compatible elastomer thermal barrier that provides a minimum of 1/4" separation; EPDM exterior glazing seals secured by extended pressure plates fastened to tongue of back member; provisions to lead moisture accumulation to exterior at all sealed horizontals; and a cover that snaps over pressure plate to show only a sharp, uninterrupted exterior profile.
 - 2. Pressure Plate Material: Fiberglass
 - 3. Glazing Plane: Front
 - 4. Aluminum vertical and horizontal main frame extrusions shall have a minimum wall thickness of .070.

5. Frame components shall be mechanically fastened by means of extruded aluminum shear blocks attached to vertical mullions.
 6. Dimensions of Framing Members: Provide framing with vertical and horizontal framing members having a nominal face dimension of 2-1/2 inches, and overall depth of 6 inches and 10-1/2 inches, as indicated on Drawings.
 7. Finish: Three-Coat PVDF
 8. Basis of Design Product: Provide 4-sided captured system 1600¹ Wall System by Kawneer Company, Inc., an Arconic Company, or equal products by one of the following:
 - a. EFCO Corp
 - b. YKK
- B. Curtain Wall System for Triple Glazing Manufacturer's standard extruded-aluminum framing members for multi-story curtainwall application of thickness required and reinforced as required to support imposed loads. Provide outside glazed system, with pressure plate, captured horizontal and vertical mullions.
1. Provide mullion configuration with pockets at the inside glazing face to receive fixed resilient elastomeric glazing seal; flexible silicone-compatible elastomer thermal barrier that provides a minimum of 1/4" separation; EPDM exterior glazing seals secured by extended pressure plates fastened to tongue of back member; provisions to lead moisture accumulation to exterior at all sealed horizontals; and a cover that snaps over pressure plate to show only a sharp, uninterrupted exterior profile.
 2. Glazing Plane: Front
 3. Aluminum vertical and horizontal main frame extrusions shall have a minimum wall thickness of .070.
 4. Frame components shall be mechanically fastened by means of extruded aluminum shear blocks attached to vertical mullions.
 5. Dimensions of Framing Members: Provide framing with vertical and horizontal framing members having a nominal face dimension of 2 inches, and overall depth of 6-3/4 inches, as indicated on Drawings.
 6. Finish: Three-Coat PVDF
 7. Basis of Design Product: Provide 4-sided captured system 1620UT Wall System by Kawneer Company, Inc., an Arconic Company, or equal products by one of the following:
 - a. EFCO Corp
 - b. YKK
- C. Brackets and Reinforcements: Provide manufacturer's standard high-strength aluminum brackets and reinforcements. Provide nonstaining, nonferrous shims for aligning system components.
1. Provide all required accessories (fasteners, clips, brackets, supports, etc.) required for adjustment and installation as required by field conditions.

- D. Fasteners and Accessories: Manufacturer's standard corrosion-resistant, nonstaining, nonbleeding fasteners and accessories compatible with adjacent materials. Finish exposed portions to match glazed aluminum curtain wall.
 - 1. At movement joints, use slip-joint linings, spacers, and sleeves of material and type recommended by manufacturer.
 - 2. Where fasteners anchor into aluminum less than 0.125 inch (3.2 mm) thick, provide reinforcement to receive fastener threads.
 - 3. Use concealed fasteners, unless otherwise indicated.
 - 4. Provide all required accessories (fasteners, clips, brackets, supports, etc.) required for adjustment and installation as required by field conditions.

- E. Anchors: 3-way adjustable anchors that accommodate fabrication and installation tolerances in material and finish compatible with adjoining materials and recommended by manufacturer.
 - 1. Concrete and Masonry Inserts: Hot-dip galvanized cast-iron, malleable-iron, or steel inserts complying with ASTM A 123 or ASTM A 153 requirements.

- F. Concealed Flashing: Dead-soft, 0.018-inch- (0.457-mm-) thick stainless steel, complying with ASTM A 666, of type selected by manufacturer for compatibility with system..

- G. Insulating Materials: Provide fiberglass batts for stuffing in openings and cracks.

2.5 PROJECTED WINDOWS

- A. Basis of Design Product: Provide GLASSvent UT Windows, Outswing Casement by Kawneer or equal.

- B. Rescue Windows: Fabricate all window units designated as "Rescue" windows on drawings to comply with local and state codes for emergency egress windows. Provide a minimum clear opening of 6 square feet, with minimum 24" clearance for opening width and height. Rescue window maximum 54" to operating hardware.

- C. Provide outswing casement windows designed for insertion in storefront framing with minimal sightlines and interior face of the intermediate mullion in alignment and flush with storefront horizontal.

- D. Hardware: Provide the following equipment and operating hardware:
 - 1. Hinges: Concealed stainless steel heavy-duty 4-bar friction hinges with adjustable slide shoe (2 per ventilator); *Truth Series 301*.
 - 2. Lock: Three Cam-action, sweep lock handles with surface-mounted strike.
 - 3. Limit Device: Stay bar with adjustable hold-open device.
 - 4. Screen Hinge: Continuous stainless steel.
 - 5. Screen Latch: Cast aluminum, operable from interior or exterior.

- E. Fabrication: Fabricate aluminum window units to comply with indicated standards. Include a complete system for assembly of components and anchorage of window units. Provide interior aluminum frame adapter of mitered and screw splined that is attached to the storefront framing with concealed fasteners, with tubular vent frame with screw splined corners construction, containing three sided concealed structural silicone glazed system with fourth side exposed structural glazed silicone that does not add to the exterior sightlines of the storefront framing, with bulb and fin type weather stripping that is mounted to extrusions that fits into the storefront framing glass pocket.
- F. Depth: 4-3/8 inches.
- G. Finish: Kawneer Permafluor (70% PVDF) Fluoropolymer coating meeting AAMA 2605, or equal, in Charcoal UC109852.
- H. Thermally Improved Construction: Fabricate window units with an integral, concealed, low-conductance, thermal barrier, located between exterior materials and window members exposed on interior, in a manner that eliminates direct metal-to-metal contact.
 - 1. Provide exterior glazed units with minimal or no aluminum exposed to the exterior or poured-in-place two part polyurethane thermal-break construction that has been in use for not less than three (3) years, has been tested to demonstrate resistance to thermal conductance and condensation, and has been tested to show adequate strength and security of glass retention and compliance with the CRF indicated in Part 1, Article Performance Requirements.
 - 2. Weep Holes: Provide weep holes and internal passages to conduct infiltrating water to exterior. Pressure equalized each vent utilizing two rows of weather-stripping installed in specifically designed dovetail grooves in the extrusion, omit on bottom of vent to allow pressure equalization and drainage.
 - 3. Subframes Frames: Provide subframes with anchors for window units as shown, of profile and dimensions indicated but not less than 0.125-inch- thick extruded aluminum. Cope and screw spline corners.
 - 4. Vent Frames: Provide vents of tubular extrusions of profile and dimensions indicated but not less than 0.156-inch- thick extruded aluminum. Miter corners, angle reinforce, crimp cold, epoxy weld, seal and dress smooth with concealed mechanical joint fasteners.
- I. Preglazed Fabrication: Preglaze projected window units at the factory. Comply with glass and glazing requirements of Division 08 Section "Glazing" of these Specifications and AAMA 101.
 - 1. Glaze all units with four-sided structural glazed silicone. Only factory glazing of the structural silicone shall be acceptable..
 - 2. Prepare surfaces that will contact structural sealant according to sealant manufacturer's written instructions to ensure compatibility and adhesion. Preparation includes, but is not limited to, cleaning and priming surfaces.
 - 3. Install structural silicone sealant according to sealant manufacturer's written instructions.
 - 4. Mechanically fasten glazing in place until structural sealant is cured.

5. Remove excess sealant from component surfaces before sealant has cured.
 6. Absolutely no field application of structural sealant for operable units is permitted.
- J. Insect Screens: Provide insect screens for each operable exterior ventilator. Locate screens on the inside of the window sash or ventilator. Design windows and hardware to accommodate screens in a tight-fitting removable arrangement, with a minimum of exposed fasteners and latches.
1. Wickets: Provide full height screen hinged-type wickets, framed and trimmed for a tight fit and durability during handling. Provide continuous full side hinge screens. Mount continuous hinge to screen frame and window frame, so that hinge leaves are concealed, when viewed from exterior and interior. Provide appropriate size hinge leaf width to facilitate maintenance re-screening. Hinge length to be flush with top and bottom of screen frame. Provide one latch, which matches hinge finish, at mid span of each screen.
 2. Screen Frames: Fabricate frames of tubular-shaped extruded aluminum members of 0.040-inch minimum wall thickness, with mitered or coped joints and concealed mechanical fasteners. Finish frames to match window units.
 - a. Provide removable extruded PVC spline-anchor concealing the edge of the screen frame

2.6 CURTAINWALL FABRICATION

- A. General: Fabricate glazed aluminum curtain wall system according to Shop Drawings. Fabricate components that, when assembled, will have accurately fitted joints with ends coped or mitered to produce hairline joints free of burrs and distortion. After fabrication, clearly mark components to identify their locations in Project according to Shop Drawings.
- B. Forming: Form shapes with sharp profiles, straight and free of defects or deformations, before finishing.
- C. Prepare components to receive concealed fasteners and anchor and connection devices.
- D. Fabricate components to drain water passing joints, condensation occurring in glazing channels, condensation occurring within framing members, and moisture migrating within the system to the exterior.
- E. Glazing Pockets: Provide minimum clearances for thickness and type of glass indicated according to GANA's "Glazing Manual."
- F. Metal Protection: Where aluminum will contact dissimilar metals, protect against galvanic action by painting contact surfaces with primer or by applying sealant or tape recommended by manufacturer for this purpose. Where aluminum will contact concrete or masonry, protect against corrosion by painting contact surfaces with bituminous paint.
- G. Frame Units: Factory assemble frame units according to Shop Drawings to greatest extent possible. Rigidly secure nonmovement joints. Seal joints watertight, unless otherwise indicated.

- H. Prefabrication: Complete fabrication, assembly, finishing, hardware application, and other work to the greatest extent possible before shipment to the Project site. Disassemble components only as necessary for shipment and installation.
 - 1. Perform fabrication operations, including cutting, fitting, forming, drilling and grinding of metal work to prevent damage to exposed finish surfaces. Complete these operations for hardware prior to application of finishes.
 - 2. Do not preglaze framing system. Refer to Division 08 Section "Glazing" for specifications.
- I. Reinforcing: Install reinforcing as required for hardware and as necessary for performance requirements, sag resistance and rigidity.

2.7 ALUMINUM FINISHES

- A. General: Comply with NAAMM's "Metal Finishes Manual for Architectural and Metal Products" for recommendations relative to applying and designating finishes.
- B. Appearance of Finished Work: Variations in appearance of abutting or adjacent pieces are acceptable if they are within one-half of the range of approved Samples. Noticeable variations in the same piece are not acceptable. Variations in appearance of other components are acceptable if they are within the range of approved Samples and are assembled or installed to minimize contrast.
- C. Finish designations prefixed by AA conform to the system established by the Aluminum Association for designating aluminum finishes.
- D. Superior-Performance Organic Finish, Three-Coat PVDF: Fluoropolymer finish complying with AAMA 2605 and containing not less than 70 percent PVDF resin by weight in both color coat and clear topcoat.
 - 1. Prepare, pretreat, and apply coating to exposed metal surfaces to comply with coating and resin manufacturers' written instructions.
 - 2. Color and Gloss: Kawneer Permafluor Charcoal UC109852.

PART 3 - EXECUTION

3.1 EXAMINATION

- A. Examine areas, with Installer present, for compliance with requirements for installation tolerances and other conditions affecting performance of glazed aluminum curtain wall system. Do not proceed with installation until unsatisfactory conditions have been corrected or accommodations acceptable to Architect have been made.

3.2 INSTALLATION

- A. General: Comply with manufacturer's written instructions for protecting, handling, and installing glazed aluminum curtain wall system. Do not install damaged components. Fit joints to produce hairline joints free of burrs and distortion. Rigidly secure nonmovement joints. Seal joints watertight, unless otherwise indicated. Provide means to drain water to the exterior to produce a permanently weatherproof system.
- B. Metal Protection: Where aluminum will contact dissimilar metals, protect against galvanic action by painting contact surfaces with primer or by applying sealant or tape recommended by manufacturer for this purpose. Where aluminum will contact concrete or masonry, protect against corrosion by painting contact surfaces with bituminous paint.
- C. Install components to drain water passing joints, condensation occurring in glazing channels, condensation occurring within framing members, and moisture migrating within the system to the exterior.
- D. Install factory-assembled frame units plumb and true in alignment with established lines and grades.
- E. Anchorage: After system components are positioned, fix connections to building structure as indicated on Shop Drawings.
 - 1. Provide separators and isolators to prevent metal corrosion and electrolytic deterioration and to prevent impeding movement of moving joints.
- F. Install windows in curtainwall framing in compliance with manufacturer's directions and approved shop drawings.
- G. Install glazing according to Shop Drawings. Comply with requirements of Division 08 Section "Glazing," unless otherwise indicated.
- H. Install sealant according to Shop Drawings. Comply with requirements of Division 07 Section "Joint Sealants," unless otherwise indicated.
- I. Install insulation materials in locations indicated, and at perimeter of curtainwall system stuffed into openings. Comply with requirements of Division 07 Section "Building Insulation," unless otherwise indicated.
- J. Install firestop in locations indicated. Comply with requirements of Division 07 Section "Firestop Joint Systems," unless otherwise indicated.
- K. Erection Tolerances: Install glazed aluminum curtain wall system to comply with the following maximum tolerances:
 - 1. Plumb: 1/8 inch in 10 feet (3 mm in 3 m); 1/4 inch in 40 feet (6 mm in 12 m).
 - 2. Level: 1/8 inch in 20 feet (3 mm in 6 m); 1/4 inch in 40 feet (6 mm in 12 m).
 - 3. Alignment: Where surfaces abut in line, limit offset from true alignment to 1/16 inch (1.5 mm); where a reveal or protruding element separates aligned surfaces by less than 2 inches (50.8 mm), limit offset to 1/2 inch (12.7 mm).

4. Location: Limit variation from plane or location shown on Shop Drawings to 1/8 inch in 12 feet (3 mm in 3.7 m); 1/2 inch (12.7 mm) over total length.

3.3 ADJUSTING AND CLEANING

- A. Clean exposed surfaces of systems that are not protected by temporary covering, to remove fingerprints and soil during construction period. Do not allow soil to accumulate until final cleaning.
- B. Before final inspection, clean exposed surfaces with water and a mild soap or detergent not harmful to finishes. Thoroughly rinse surfaces and dry.
- C. Restore system units damaged during installation and construction so no evidence remains of corrective work. If results of restoration are unsuccessful, as determined by Architect, remove damaged units and replace with new units.
 1. Touch-up minor abrasions with air-dried coating that matches color and gloss of, and is compatible with, factory-applied finish coating.

3.4 PROTECTION

- A. Provide final protection and maintain conditions, in a manner acceptable to manufacturer and Installer, that ensure glazed aluminum curtain wall system is without damage or deterioration at the time of Substantial Completion.

END OF SECTION 084413

SECTION 085656 - TRANSACTION WINDOWS

PART 1 - GENERAL

1.1 SUMMARY

- A. Section Includes:
 - 1. Sliding transaction windows.

1.2 COORDINATION

- A. Coordinate installation of anchorages for transaction windows. Furnish setting drawings, templates, and directions for installing anchorages, including sleeves, concrete inserts, anchor bolts, and items with integral anchors, that are to be embedded in adjacent construction. Deliver such items to Project site in time for installation.

1.3 ACTION SUBMITTALS

- A. Product Data: For each type of product.
 - 1. Include construction details, material descriptions, dimensions of individual components and profiles, and finishes for window units.
- B. Shop Drawings: For transaction windows.
 - 1. Include plans, elevations, sections, and attachments to other work.
 - 2. Full-size section details of framing members, including internal armoring, reinforcement, and stiffeners.
 - 3. Glazing details.
 - 4. Keying information
- C. Samples for Initial Selection: Of manufacturer's available colors for powder paint finish.

1.4 INFORMATIONAL SUBMITTALS

- A. Operation and Maintenance Data: To include in operation and maintenance manuals.

1.5 DELIVERY, STORAGE, AND HANDLING

- A. Pack transaction windows in wood crates for shipment.
- B. Label transaction window packaging with drawing designation.
- C. Store crated transaction windows on raised blocks to prevent moisture damage.

PART 2 - PRODUCTS

2.1 PERFORMANCE CRITERIA

- A. Horizontal sliding steel windows shall conform to the HS-C30 voluntary specifications in AAMA/NWWDA 101/I.S.2-97 and be designed to meet the performance requirements listed herein.

2.2 FABRICATION

- A. General: Fabricate self-closing and self-latching horizontal sliding transaction windows to provide a complete system for assembly of components and anchorage of window units.

- 1. Provide factory preglazed transaction windows.

- B. Framing: Miter or cope corners the full depth of framing; weld and dress smooth.

- C. Fabricate from 6063-T6 aluminum extrusions with one fixed and one sliding panel (OX or XO); refer to drawings for locations of sliding panels at each opening. Units shall be self-closing and self-latching with a thumbturn deadlock and a locked/unlocked indicator. Removable header access panel shall house heavy-duty anti-lift ball bearing carrier for operable panel. Bottom track for operable panel shall be vinyl.

- 1. Provide unit with aluminum half bottom track with clear service opening and no track under slider.

- 2. Dimensions:

- a. Frame depth 4-1/2"

- b. Header height 2-7/8"

- c. Center sightline 1-1/2"

- d. Center and end stiles, top rail and bottom rail 15/16"

- e. Width and height of unit shall be as indicated on Drawings for each location.

- 3. Basis of Design Product: CRL SCDW1801P by CR Laurence, or equal.

- D. Glazing: Factory glaze with SG5 security glazing by School Guard Glass.

- E. Finish: Provide powder coat painted finish, manufacturer's standard system, in RAL color selected by Architect.

2.3 ACCESSORIES

- A. Anchors, Fasteners, Clips, and Window Accessories: Stainless steel; hot-dip, zinc-coated steel or iron, complying with ASTM B 633.

- B. Sealants: For sealants required within fabricated transaction windows, provide type recommended by manufacturer for joint size and movement. Sealant shall remain permanently elastic, nonshrinking, and nonmigrating.

PART 3 - EXECUTION

3.1 EXAMINATION

- A. Examine substrates, areas, and conditions, with Installer present, for compliance with requirements for installation tolerances and other conditions affecting performance of transaction windows.
- B. Examine in-place construction for compliance with manufacturer's installation requirements before transaction window installation.
- C. For the record, prepare written report, endorsed by Installer, listing conditions detrimental to performance of transaction windows.
- D. Proceed with installation only after unsatisfactory conditions have been corrected.

3.2 INSTALLATION

- A. Fastening to In-Place Construction: Provide anchorage devices and fasteners where necessary for securing transaction windows to in-place construction. Include threaded fasteners for inserts, security fasteners, and other connectors.
- B. Fasteners: Install transaction windows using fasteners recommended by manufacturer with head style appropriate for installation requirements, strength, and finish of adjacent materials. Provide stainless-steel fasteners.
- C. Sealants: Comply with requirements in Section 079200 "Joint Sealants" for installing sealants, fillers, and gaskets.

3.3 ADJUSTING

- A. Remove and replace defective work, including transaction windows that are warped, bowed, or otherwise unacceptable.
- B. Adjust for smooth operation of sliding windows

3.4 CLEANING AND PROTECTION

- A. Clean surfaces promptly after installation of transaction windows. Take care to avoid damaging the finish. Remove excess glazing and sealant compounds, dirt, and other substances.
- B. Clean glass of preglazed transaction windows promptly after installation.
- C. Provide temporary protection to ensure that transaction windows are without damage at time of Substantial Completion.

END OF SECTION 085656

SECTION 086200 - UNIT SKYLIGHTS

PART 1 - GENERAL

1.1 SUMMARY

- A. This Section includes factory-assembled unit skylights for installation in flat roof areas.
 - 1. Type: Double-dome, metal-framed, curb-mounted unit.
 - 2. Glazing: Impact modified plastic glazing domes and 10mm multiwall laylight panel filled with Lumira™ aerogel.
 - 3. Safety Screens: Metal mesh safety screen mounted on exterior of unit.
 - 4. Pre-fabricated curbs for unit skylights.
- B. Related Sections include the following:
 - 1. Division 6 Section "Miscellaneous Carpentry" for wood framing and blocking at unit skylights.
 - 2. Division 07 Section "Sheet Metal Flashing and Trim" for flashing at unit skylights.
 - 3. Division 08 Section "Metal-Framed Skylights" for site-erected, metal-framed, nonunitized, monumental units.

1.2 PERFORMANCE REQUIREMENTS

- A. Structural Loads: Provide unit skylights, including glazing and anchorage, meeting requirements of uniform load test per ASTM E330 capable of withstanding the effects of the following design loads:
 - 1. Positive and Negative Pressure (Uplift) Load: As indicated on Structural Drawings.
 - 2. Snow Load: As indicated on Structural Drawings.
- B. Fall Protection: Tested to meet or exceed the intent of OSHA29CFR 1910.23(e)(8) for fall protection.
- C. Unit skylights must be tested and certified by NFRC for thermal performance. Products must be listed on the NFRC Certified Products directory.
- D. Glazing System Performance:
 - 1. U-factor shall be .61 BTU/HR-ft²-F maximum per NFRC 100.
 - 2. SHGC shall be .45 maximum per NFRC 200
 - 3. Visible Light Transmission shall be 60% per ASTM E972

1.3 SUBMITTALS

- A. Product Data: For unit skylights. Include construction details, material descriptions, dimensions of individual components and profiles, and finishes.

- B. Shop Drawings: For unit skylights. Include plans, elevations, sections, details, and attachments to other Work.

1.4 QUALITY ASSURANCE

A. Fire-Test Response Characteristics:

1. Provide thermoformed domes fabricated from sheets identical to those tested for the following fire-test-response characteristics, per ASTM test method indicated below, by UL or other testing and inspecting agencies acceptable to authorities having jurisdiction. Identify plastic sheets with appropriate markings of applicable testing and inspecting organization.
 - a. Self-Ignition Temperature: 651 deg F (343 deg C) or greater for plastic sheets in thickness indicated for use when tested per ASTM D 1929.
 - b. Smoke Density: 75 or less when tested per ASTM D 2843 on plastic sheets in thickness indicated for use.
 - c. Relative-Burning Characteristics: Tested per ASTM D 635; Class CC2, burning rate of 2-1/2 inches (64 mm) per minute or less for nominal thickness of 0.060 inch (1.5 mm) or thickness indicated for use.
2. Provide flat cellular polycarbonate panel fabricated from an approved cellular polycarbonate glazing (light transmitting) material identical to that tested with a CC1 fire rating classification per ASTM D-635 and filled with Lumira™ Aerogel insulation in the thickness (10mm) intended for use.
 - a. Self-Ignition Temperature: 1110° F (599 deg. C) or greater when tested per ASTM 1929 on multi-wall cellular panel filled with Lumira™ aerogel Insulation in the thickness (10mm) intended for use.

1.5 WARRANTY

- A. Skylight Special Warranty: Provide written warranty signed by manufacturer, agreeing to repair or replace work that exhibits defects in materials or workmanship and guaranteeing weather-tight and leak-free performance. "Defects" is defined as uncontrolled leakage of water and abnormal aging or deterioration.
 1. Warranty Period: 5 years from date of Substantial Completion.
- B. Plastic Warranty: Provide written warranty signed by manufacturer agreeing to repair or replace work that has or develops defects in the plastic. "Defects" is defined as abnormal aging or deterioration.
 1. Warranty Period: 5 years from date of Substantial Completion against yellowing or breakage.
- C. Finish Warranty: Provide written warranty signed by manufacturer agreeing to repair or replace work with finish defects. "Defects" is defined as peeling, chipping, chalking, fading, abnormal aging or deterioration, and failure to perform as required.

1. Warranty Period for Anodized Finish: 1 year from date of Substantial Completion.
2. Warranty Period Polyester Powder Coat: 5 year from date of Substantial Completion.
3. Warranty Period for Kynar 500 Finish: 5 years from date of Substantial Completion. (10 and 20 year available if specified).

PART 2 - PRODUCTS

2.1 MATERIALS

- A. Curb Frame: High performance PVC with minimum effective thickness of 0.060 inch (1.5mm). Provide integral condensation gutter system with corners fully welded.
- B. Retainer Frame: Extruded aluminum alloy 6063-T5 (min). ASTM B 221 (ASTM B 221 M) with minimum effective thickness of 0.60 inch (1.5 mm).
- C. Dome Glazing: Thermoformed acrylic.
- D. Interior Laylite: 10mm multi-wall flat cellular polycarbonate panel filled with Lumira™ aerogel insulating material.
- E. Thermal Break: Fabricate skylight units with thermal chambered PVC.
- F. Gaskets: Structural glazing tape to form adhesive bond between PVC curb and inner laylite, between inner laylite and inner dome, and between inner and outer dome. Butyl tape between outer dome and extruded aluminum retainer. Gaskets shall form an air and water impenetrable barrier between adjacent surfaces.
- G. Fasteners: Same metal as metals being fastened, or nonmagnetic stainless steel or other non-corrosive metal as recommended by manufacturer.

2.2 UNIT SKYLIGHTS

- A. General: Factory-assembled curb-mounted units consisting of impact modified plastic glazing and polycarbonate panel filled with Lumira™ aerogel, gasketing, and inner frame designed to mount on separate curb that is capable of withstanding design loads indicated.
 1. Basis of Design Products: Provide EcoSky3 Model CLC3 by Wasco Skylights, part of the Velux commercial Group or equal products by one of the following:
 - a. American Skylights
 - b. Kingspan Light + Air, LLC
- B. Condensation Control: Fabricate skylight units with integral internal gutters and weeps to collect and dispose of condensation.
- C. Thermal Break: Fabricate skylight units with thermal chambered PVC.

- D. Shape and Size: 48" x 48" square.
- E. Outer Glazing: Dome thermoformed translucent IR reflecting Acrylite® SatinSky 2.
- F. Middle Glazing: Dome thermoformed clear acrylic.
- G. Inner Laylite: 10mm Multi-wall flat cellular polycarbonate panel filled with Lumira™ aerogel insulation material.

2.3 FABRICATION

- A. Framing Components: As follows:
 - 1. Factory fit and assemble components.
 - 2. Fabricate components to drain condensation and moisture occurring or migrating within skylight system to the exterior.
 - 3. Fabricate components to accommodate expansion, contraction, and field adjustment, and to provide for minimum clearance and shimming at skylight perimeter.
 - 4. Fabricate components to ensure that glazing is thermally and physically isolated from framing members.
 - 5. Fit and secure joints in aluminum by heliarc welding
- B. Glazing: Factory glaze all glazing units.

2.4 SAFETY SCREENS

- A. Safety Screens: Fabricate from welded steel wire mesh, 4" x 4" spacing, wire diameter - .188" min. hot dipped galvanized finish on carbon steel attached to extruded aluminum alloy 6063-T5 (min) . ASTM B 221 (ASTM B 221 M) with minimum effective thickness of 0.090 inch (2.2 mm), with extruded aluminum adjustment bar.
 - 1. Basis of Design Product: Provide Model CAEW Skylight Protection Screen by Wasco Skylights, part of the Velux commercial Group or equal products by one of the following:
 - a. American Skylights
 - b. Kingspan Light + Air, LLC

2.5 PRE-FABRICATED CURBS FOR UNIT SKYLIGHTS

- A. Provide thermally broken sheet aluminum curb with aluminum liners, 1-1/2" thick rigid insulation, 2" x 2" wood nailer and HS adhesive clamping at corners.
 - 1. Curb Height: 16"
 - 2. R-Value: 5.8
 - 3. Interior aluminum liners paint color as selected by Architect.

4. Basis of Design Product: Provide Model CCAW Thermally Enhanced Curb by Wasco Skylights, part of the Velux commercial Group or equal products by one of the following:
 - a. American Skylights
 - b. Kingspan Light + Air, LLC

2.6 ALUMINUM FINISHES

- A. General: Comply with NAAMM's "Metal Finishes Manual for Architectural and Metal Products" for recommendations for applying and designating finishes.
- B. Finish designations prefixed by AA comply with the system established by the Aluminum Association for designating aluminum finishes.
- C. Class I, Clear Anodic Finish: AA-M12C22A41 (Mechanical Finish: nonspecular as fabricated; Chemical Finish: etched, medium matte; Anodic Coating: Architectural Class I, clear coating 0.018 mm or thicker) complying with AAMA 611.

PART 3 - EXECUTION

3.1 INSTALLATION

- A. Coordinate unit skylight and prefabricated curb installation with installation of substrates, vapor retarders, roof insulation, roofing, and flashing as required to ensure that each element of the Work performs properly and that combined elements are waterproof and weathertight.
- B. Where metal surfaces of units will contact incompatible metal or corrosive substrates, including wood, apply bituminous coating on concealed metal surfaces, or provide other permanent separation recommended in writing by unit skylight manufacturer.
- C. Anchor unit skylights and curbs securely to supporting substrates.
- D. Set unit skylight flanges in thick bed of roofing cement to form a seal, unless otherwise indicated.
- E. Where cap flashing is indicated, install to produce waterproof overlap with roofing or roof flashing. Seal with thick bead of mastic sealant except where overlap is indicated to be left open for ventilation.

3.2 CLEANING

- A. Clean exposed surfaces according to manufacturer's written instructions. Touch up damaged metal coatings.

END OF SECTION 086200

SECTION 086300 - METAL-FRAMED SKYLIGHTS

PART 1 - GENERAL

1.1 SUMMARY

- A. This Section includes aluminum-framed skylights with the following characteristics:
 - 1. Glazing is glass.
 - 2. Glazing is retained by field-installed pressure caps on four sides
- B. Related Sections include the following:
 - 1. Division 07 Section "Joint Sealants" for sealants installed at perimeters of metal-framed skylights.
 - 2. Division 08 Section "Glazing" for glass units installed in metal-framed skylights.

1.2 PERFORMANCE REQUIREMENTS

- A. Delegated Design: Engage a qualified professional engineer, as defined in Section 014000 "Quality and Code Requirements," to design metal-framed skylights.
- B. Provide metal-framed skylights, including anchorage, capable of withstanding, without failure, the effects of the following:
 - 1. Structural loads.
 - 2. Thermal movements.
 - 3. Movements of supporting structure.
 - 4. Dimensional tolerances of building frame and other adjacent construction.
- C. Failure includes the following:
 - 1. Deflection exceeding specified limits.
 - 2. Water leakage.
 - 3. Thermal stresses transferred to building structure.
 - 4. Noise or vibration created by wind and thermal and structural movements.
 - 5. Framing members transferring stresses, including those caused by thermal and structural movements, to glazing.
 - 6. Loosening or weakening of fasteners, attachments, and other components.
 - 7. Sealant failure.
- D. Structural Loads:
 - 1. Wind Loads, Snow Loads, Earthquake Loads: As indicated by structural design data on Drawings.

2. Concentrated Live Loads: 300 lbf applied to framing members at locations that will produce greatest stress or deflection.
3. Load Combinations: Calculate according to requirements of applicable code indicated on Drawings.

E. Deflection of Framing Members:

1. Deflection Normal to Glazing Plane: Limited to edge of glass in a direction perpendicular to glass plane not exceeding $L/175$ of the glass edge length for each individual glazing lite or an amount that restricts edge deflection of individual glazing lites to 3/4 inch (19.1 mm), whichever is less.
2. Deflection Parallel to Glazing Plane: Limited to $L/360$ of clear span or 1/8 inch (3.2 mm), whichever is smaller.

F. Lateral Bracing of Framing Members: Compression flanges of flexural members are laterally braced by cross members with minimum depth equal to 50 percent of flexural member that is braced. Glazing does not provide lateral support.

G. Thermal Movements: Allow for thermal movements from ambient and surface temperature changes. Base engineering calculation on surface temperatures of materials due to both solar heat gain and nighttime-sky heat loss.

1. Temperature Change (Range): 120 deg F (67 deg C), ambient; 180 deg F (100 deg C), material surfaces.

1.3 PERFORMANCE TESTING

- A. Provide metal-framed skylights that comply with test-performance requirements indicated, as evidenced by reports of tests performed on manufacturer's standard assemblies by a qualified independent testing agency.
- B. Structural-Performance: Provide metal-framed skylights, including anchorage, capable of withstanding pressures indicated without material and deflection failures and permanent deformation of structural members exceeding 0.2 percent of span when tested according to ASTM E 330.
- C. Air-Infiltration: Metal-framed skylights with maximum air leakage through fixed glazing and framing areas of 0.01 cfm/sq. ft. (0.05 L/s per sq. m) of surface when tested according to ASTM E 283 at a minimum static-air-pressure difference of 6.24 lbf/sq. ft. (300 Pa)
- D. Water Penetration under Static Pressure Metal-framed skylights that do not evidence water penetration through fixed glazing and framing areas when tested according to ASTM E 331 at a minimum static-air-pressure difference of 20 percent of positive wind-load design pressure, but not less than 15 lbf/sq. ft. (718 Pa).

- E. Condensation Resistance: Provide aluminum-framed systems that when tested with fixed glazing, have a frame condensation-resistance factor (CR) of not less than 46 when tested according to NFRC 500 when clear over clear insulated glass is used.
- F. Energy Performance: Provide metal-framed skylights with performance properties specified, as indicated in manufacturer's published test data, based on procedures indicated below and certified and labeled according to NFRC:
 - 1. Thermal Transmittance (U-Factor): Fixed glazing and framing areas shall have U-factor of not more than 0.40 Btu/sq. ft. x h x deg F as determined according to NFRC 100.

1.4 SUBMITTALS

- A. Product Data: Include construction details, material descriptions, dimensions of individual components and profiles, and finishes for metal-framed skylights.
- B. Shop Drawings: For metal-framed skylights. Include plans, elevations, sections, details, and attachments to other work.
 - 1. Indicate structural loadings and reactions to be transmitted to supporting curbs.
 - 2. Include details of provisions for assembly expansion and contraction and for draining moisture within the assembly to the exterior..
- C. Delegated-Design Submittal: For metal-framed skylights indicated to comply with performance requirements and design criteria, including analysis data signed and sealed by the qualified professional engineer responsible for their preparation.
- D. Fabrication Sample: Of each framing intersection of assemblies, made from 12-inch (300-mm) lengths of full-size components and showing details of the following:
 - 1. Joinery.
 - 2. Anchorage.
 - 3. Expansion provisions.
 - 4. Glazing.
 - 5. Flashing and drainage.
- E. Product Test Reports: Based on evaluation of comprehensive tests performed by a qualified testing agency, for metal-framed skylights.
- F. Maintenance Data: For metal-framed skylights to include in maintenance manuals.
- G. Warranties: Special warranties specified in this Section.

1.5 QUALITY ASSURANCE

- A. Installer Qualifications: Manufacturer's authorized representative who is trained and approved for installation of metal-framed skylights required for this Project.

- B. Professional Engineer Qualifications: A professional engineer who is legally qualified to practice in jurisdiction where Project is located and who is experienced in providing engineering services of the kind indicated. Engineering services are defined as those performed for installations of metal skylights that are similar to those indicated for this Project in material, design, and extent
- C. Testing Agency Qualifications: An independent agency qualified according to ASTM E 699 for testing indicated.
- D. Product Options: Information on Drawings and in Specifications establishes requirements for skylights' aesthetic effects and performance characteristics. Aesthetic effects are indicated by dimensions, arrangements, alignment, and profiles of components and assemblies as they relate to sightlines, to one another, and to adjoining construction. Performance characteristics are indicated by criteria subject to verification by one or more methods including testing conducted by an independent testing agency and in-service performance.
 - 1. Do not modify intended aesthetic effects, as judged solely by Architect, except with Architect's approval. If modifications are proposed, submit comprehensive explanatory data to Architect for review.

1.6 PROJECT CONDITIONS

- A. Field Measurements: Where metal-framed skylights are indicated to fit to other construction, verify dimensions of other construction by field measurements before fabrication and indicate measurements on Shop Drawings.

1.7 WARRANTY

- A. Special Assembly Warranty: Manufacturer's standard form in which manufacturer agrees to repair or replace components of metal-framed skylights that fail in materials or workmanship within specified warranty period.
 - 1. Failures include, but are not limited to, the following:
 - a. Structural failures including, but not limited to, excessive deflection.
 - b. Noise or vibration caused by thermal movements.
 - c. Deterioration of metals, metal finishes, and other materials beyond normal weathering.
 - d. Adhesive or cohesive sealant failures.
 - e. Water leakage.
 - 2. Warranty Period: Five years from date of Substantial Completion.
- B. Finish Special Warranty: Provide written warranty signed by manufacturer agreeing to repair or replace work with finish defects. "Defects" is defined as peeling, chipping, chalking, fading, abnormal aging or deterioration, and failure to perform as required.

1. Warranty Period for Kynar 500 Finish: 10 years from date of Substantial Completion.

PART 2 - PRODUCTS

2.1 MANUFACTURERS

- A. Basis-of-Design Product: The design for metal-framed skylights is based on Pinnacle 350 Skylight manufactured by Wasco Division, Velux Commercial. Subject to compliance with requirements, provide the named product or a comparable product by one of the following, or equal:
 1. Kawneer
 2. Super Sky Products Inc.

2.2 FRAMING MATERIALS

- A. Aluminum: Alloy and temper recommended in writing by manufacturer for type of use and finish indicated.
 1. Sheet and Plate: ASTM B 209 (ASTM B 209M).
 2. Extruded Bars, Rods, Profiles, and Tubes: ASTM B 221 (ASTM B 221M).
 3. Extruded Structural Pipe and Tubes: ASTM B 429.
 4. Framing members shall have a minimum effective thickness of 0.125 inches.
- B. Pressure Caps: Manufacturer's standard aluminum components that mechanically retain glazing, with minimum effective thickness of 0.109 inches.
 1. Include snap-on aluminum trim that conceals fasteners.
- C. Brackets and Reinforcements: Manufacturer's standard high-strength aluminum with nonstaining, nonferrous shims for aligning skylight components.
- D. Anchors, Fasteners, and Accessories: Manufacturer's standard, corrosion-resistant, nonstaining, and nonbleeding; compatible with adjacent materials.
 1. Aluminum Retaining Cap Fasteners and Framing Members Fasteners: ASTM A 193/A 193M, Series 300 stainless-steel screws; type as recommended by manufacturer.
 2. Connections to Supporting Structure: Series 300 Stainless Steel or ASTM A 307, hot dipped galvanized steel fasteners by installer.
 3. Where fasteners are subject to loosening or turning out from thermal and structural movements, wind loads, or vibration, use self-locking devices.
 4. At movement joints, use slip-joint linings, spacers, and sleeves of material and type recommended in writing by manufacturer.

- E. Concrete and Masonry Inserts: Hot-dip galvanized cast-iron, malleable-iron, or steel inserts complying with ASTM A 123/A 123M or ASTM A 153/A 153M requirements.
- F. Anchor Bolts: ASTM A 307, Grade A (ASTM F 568M, Property Class 4.6), hot-dip zinc coating, ASTM A 153/A 153M, Class C.
- G. Concealed Flashing: Manufacturer's standard, corrosion-resistant, nonstaining, nonbleeding flashing compatible with adjacent materials.
- H. Exposed Flashing and Closures: Manufacturer's standard aluminum components not less than 0.032 inch thick for apron flashing and 0.062 inch for closures..
- I. Framing Gaskets: Manufacturer's standard.
- J. Framing Sealants: As recommended in writing by manufacturer.
 - 1. Sealant shall have a VOC content of 250 g/L or less.

2.3 GLAZING MATERIALS

- A. Glazing: As specified in Division 08 Section "Glazing."
- B. Spacers, Setting Blocks, and Gaskets: Manufacturer's standard elastomeric types.
- C. Glazing Sealants: As recommended in writing by manufacturer.
 - 1. Sealant shall have a VOC content of 250 g/L or less.

2.4 ACCESSORY MATERIALS

- A. Bituminous Paint: Cold-applied asphalt-mastic paint complying with SSPC-Paint 12 requirements except containing no asbestos, formulated for 30-mil (0.762-mm) thickness per coat.

2.5 FABRICATION

- A. Basis of Design Products: Pinnacle 350 Double Pitch Skylight by Wasco Division, Velux Commercial, or equal.
- B. Fabricate aluminum components before finishing.
- C. Fabricate aluminum components that, when assembled, have the following characteristics:
 - 1. Profiles that are sharp, straight, and free of defects or deformations.
 - 2. Accurately fitted joints with ends coped or mitered.

3. Internal guttering systems or other means to drain water passing joints, condensation occurring within framing members, and moisture migrating within skylight to exterior.
 4. Physical and thermal isolation of glazing from framing members.
 5. Accommodations for thermal and mechanical movements of glazing and framing to maintain required glazing edge clearances.
- D. Attach retainer bars with gasketed stainless steel fasteners spaced at a maximum of 12 inches on center.
- E. Weld components before finishing and in concealed locations to greatest extent practicable to minimize distortion.
- F. Fabricate aluminum sill closures with weep holes and for installation as continuous component.
- G. Reinforce aluminum components as required to receive fastener threads.
- H. After fabrication, clearly mark components to identify their locations in Project according to Shop Drawings.
- 2.6 ALUMINUM FINISHES
- A. General: Comply with NAAMM's "Metal Finishes Manual for Architectural and Metal Products" for recommendations for applying and designating finishes.
 - B. Finish designations prefixed by AA comply with the system established by the Aluminum Association for designating aluminum finishes.
 - C. Kynar Fluoropolymer Two-Coat System: (70% PVDF) complying with AAMA 2605. Color as selected by Architect.

PART 3 - EXECUTION

3.1 EXAMINATION

- A. Examine areas, with Installer present, for compliance with requirements for installation tolerances and other conditions affecting performance of work.
 1. Proceed with installation only after unsatisfactory conditions have been corrected.

3.2 INSTALLATION

- A. General:
 1. Comply with manufacturer's written instructions.
 2. Do not install damaged components.

3. Fit joints between aluminum components to produce hairline joints free of burrs and distortion.
 4. Rigidly secure nonmovement joints.
 5. Install anchors with separators and isolators to prevent metal corrosion and electrolytic deterioration and to prevent impeding movement of moving joints.
 6. Seal joints watertight, unless otherwise indicated.
- B. Metal Protection: Where aluminum will contact dissimilar materials, protect against galvanic action by painting contact surfaces with bituminous paint or by installing nonconductive spacers as recommended in writing by manufacturer for this purpose.
- C. Install continuous aluminum sill closure with weatherproof expansion joints and locked and sealed or welded corners. Locate weep holes at rafters.
- D. Install components to drain water passing joints, condensation occurring within framing members, and moisture migrating within skylight to exterior.
- E. Install components plumb and true in alignment with established lines and elevations.
- F. Install glazing as specified in Division 08 Section "Glazing."
- G. Erection Tolerances: Install metal-framed skylights to comply with the following maximum tolerances:
1. Alignment: Limit offset from true alignment to 1/32 inch where surfaces abut in line, edge to edge, at corners, or where a reveal or protruding element separates aligned surfaces by less than 3 inches; otherwise, limit offset to 1/8 inch.
 2. Location and Plane: Limit variation from true location and plane to 1/8 inch in 10 feet but no greater than 1/4 inch over total length.

END OF SECTION 086300

SECTION 087100 - DOOR HARDWARE

PART 1 - GENERAL

1.1 RELATED DOCUMENTS

- A. Drawings and general provisions of the Contract, including General and Supplementary Conditions and Division 1 Specification Sections, apply to this Section.

1.2 SUMMARY

- A. This Section includes commercial door hardware for the following:
 - 1. Swinging doors.
 - 2. Other doors to the extent indicated.
- B. Door hardware includes, but is not necessarily limited to, the following:
 - 1. Mechanical door hardware.
 - 2. Electromechanical door hardware.
 - 3. Cylinders specified for doors in other sections.
- C. Related Sections:
 - 1. Division 08 Section "Hollow Metal Doors and Frames".
 - 2. Division 08 Section "Flush Wood Doors".
 - 3. Division 08 Section "Fiberglass Doors",
 - 4. Division 08 Section "Aluminum-Framed Entrances and Storefronts".
- D. Codes and References: Comply with the version year adopted by the Authority Having Jurisdiction.
 - 1. ANSI A117.1 - Accessible and Usable Buildings and Facilities.
 - 2. ICC/IBC - International Building Code.
 - 3. NFPA 70 - National Electrical Code.
 - 4. NFPA 80 - Fire Doors and Windows.
 - 5. NFPA 101 - Life Safety Code.
 - 6. NFPA 105 - Installation of Smoke Door Assemblies.
 - 7. State Building Codes, Local Amendments.
- E. Standards: All hardware specified herein shall comply with the following industry standards as applicable. Any undated reference to a standard shall be interpreted as referring to the latest edition of that standard:

1. ANSI/BHMA Certified Product Standards - A156 Series.
2. UL10C - Positive Pressure Fire Tests of Door Assemblies.
3. ANSI/UL 294 - Access Control System Units.
4. UL 305 - Panic Hardware.

1.3 SUBMITTALS

- A. Product Data: Manufacturer's product data sheets including installation details, material descriptions, dimensions of individual components and profiles, operational descriptions and finishes.
- B. Door Hardware Schedule: Prepared by or under the supervision of supplier, detailing fabrication and assembly of door hardware, as well as procedures and diagrams. Coordinate the final Door Hardware Schedule with doors, frames, and related work to ensure proper size, thickness, hand, function, and finish of door hardware.
 1. Format: Comply with scheduling sequence and vertical format in DHI's "Sequence and Format for the Hardware Schedule."
 2. Organization: Organize the Door Hardware Schedule into door hardware sets indicating complete designations of every item required for each door or opening. Organize door hardware sets in same order as in the Door Hardware Sets at the end of Part 3. Submittals that do not follow the same format and order as the Door Hardware Sets will be rejected and subject to resubmission.
 3. Content: Include the following information:
 - a. Type, style, function, size, label, hand, and finish of each door hardware item.
 - b. Manufacturer of each item.
 - c. Fastenings and other pertinent information.
 - d. Location of door hardware set, cross-referenced to Drawings, both on floor plans and in door and frame schedule.
 - e. Explanation of abbreviations, symbols, and codes contained in schedule.
 - f. Mounting locations for door hardware.
 - g. Door and frame sizes and materials.
 - h. Warranty information for each product.
 4. Submittal Sequence: Submit the final Door Hardware Schedule at earliest possible date, particularly where approval of the Door Hardware Schedule must precede fabrication of other work that is critical in the Project construction schedule. Include Product Data, Samples, Shop Drawings of other work affected by door hardware, and other information essential to the coordinated review of the Door Hardware Schedule.
- C. Shop Drawings: Details of electrified access control hardware indicating the following:
 1. Wiring Diagrams: Upon receipt of approved schedules, submit detailed system wiring diagrams for power, signaling, monitoring, communication, and control of

the access control system electrified hardware. Differentiate between manufacturer-installed and field-installed wiring. Include the following:

- a. Elevation diagram of each unique access controlled opening showing location and interconnection of major system components with respect to their placement in the respective door openings.
 - b. Complete (risers, point-to-point) access control system block wiring diagrams.
 - c. Wiring instructions for each electronic component scheduled herein.
2. Electrical Coordination: Coordinate with related sections the voltages and wiring details required at electrically controlled and operated hardware openings.
- D. Keying Schedule: After a keying meeting with the owner has taken place prepare a separate keying schedule detailing final instructions. Submit the keying schedule in electronic format. Include keying system explanation, door numbers, key set symbols, hardware set numbers and special instructions. Owner must approve submitted keying schedule prior to the ordering of permanent cylinders/cores.
- E. Informational Submittals:
1. Product Test Reports: Indicating compliance with cycle testing requirements, based on evaluation of comprehensive tests performed by manufacturer and witnessed by a qualified independent testing agency.
- F. Operating and Maintenance Manuals: Provide manufacturers operating and maintenance manuals for each item comprising the complete door hardware installation in quantity as required in Division 01, Closeout Procedures.

1.4 QUALITY ASSURANCE

- A. Manufacturers Qualifications: Engage qualified manufacturers with a minimum 5 years of documented experience in producing hardware and equipment similar to that indicated for this Project and that have a proven record of successful in-service performance.
- B. Certified Products: Where specified, products must maintain a current listing in the Builders Hardware Manufacturers Association (BHMA) Certified Products Directory (CPD).
- C. Installer Qualifications: A minimum 3 years documented experience installing both standard and electrified door hardware similar in material, design, and extent to that indicated for this Project and whose work has resulted in construction with a record of successful in-service performance.
- D. Door Hardware Supplier Qualifications: Experienced commercial door hardware distributors with a minimum 5 years documented experience supplying both mechanical and electromechanical hardware installations comparable in material, design, and extent to that indicated for this Project. Supplier recognized as a factory

direct distributor by the manufacturers of the primary materials with a warehousing facility in Project's vicinity. Supplier to have on staff a certified Architectural Hardware Consultant (AHC) available during the course of the Work to consult with Contractor, Architect, and Owner concerning both standard and electromechanical door hardware and keying.

- E. Source Limitations: Obtain each type and variety of door hardware specified in this section from a single source unless otherwise indicated.
 - 1. Electrified modifications or enhancements made to a source manufacturer's product line by a secondary or third party source will not be accepted.
 - 2. Provide electromechanical door hardware from the same manufacturer as mechanical door hardware, unless otherwise indicated.
- F. Each unit to bear third party permanent label demonstrating compliance with the referenced standards.
- G. Keying Conference: Conduct conference to comply with requirements in Division 01 Section "Project Meetings." Keying conference to incorporate the following criteria into the final keying schedule document:
 - 1. Function of building, purpose of each area and degree of security required.
 - 2. Plans for existing and future key system expansion.
 - 3. Requirements for key control storage and software.
 - 4. Installation of permanent keys, cylinder cores and software.
 - 5. Address and requirements for delivery of keys.
- H. Pre-Submittal Conference: Conduct coordination conference in compliance with requirements in Division 01 Section "Project Meetings" with attendance by representatives of Supplier(s), Installer(s), and Contractor(s) to review proper methods and the procedures for receiving, handling, and installing door hardware.
 - 1. Prior to installation of door hardware, conduct a project specific training meeting to instruct the installing contractors' personnel on the proper installation and adjustment of their respective products. Product training to be attended by installers of door hardware (including electromechanical hardware) for aluminum, hollow metal and wood doors. Training will include the use of installation manuals, hardware schedules, templates and physical product samples as required.
 - 2. Inspect and discuss electrical roughing-in, power supply connections, and other preparatory work performed by other trades.
 - 3. Review sequence of operation narratives for each unique access controlled opening.
 - 4. Review and finalize construction schedule and verify availability of materials.
 - 5. Review the required inspecting, testing, commissioning, and demonstration procedures

- I. At completion of installation, provide written documentation that components were applied to manufacturer's instructions and recommendations and according to approved schedule.

1.5 DELIVERY, STORAGE, AND HANDLING

- A. Inventory door hardware on receipt and provide secure lock-up and shelving for door hardware delivered to Project site. Do not store electronic access control hardware, software or accessories at Project site without prior authorization.
- B. Tag each item or package separately with identification related to the final Door Hardware Schedule, and include basic installation instructions with each item or package.
- C. Deliver, as applicable, permanent keys, cylinders, cores, access control credentials, software and related accessories directly to Owner via registered mail or overnight package service. Instructions for delivery to the Owner shall be established at the "Keying Conference".

1.6 COORDINATION

- A. Templates: Obtain and distribute to the parties involved templates for doors, frames, and other work specified to be factory prepared for installing standard and electrified hardware. Check Shop Drawings of other work to confirm that adequate provisions are made for locating and installing hardware to comply with indicated requirements.
- B. Door Hardware and Electrical Connections: Coordinate the layout and installation of scheduled electrified door hardware and related access control equipment with required connections to source power junction boxes, low voltage power supplies, detection and monitoring hardware, and fire and detection alarm systems.
- C. Door and Frame Preparation: Doors and corresponding frames are to be prepared, reinforced and pre-wired (if applicable) to receive the installation of the specified electrified, monitoring, signaling and access control system hardware without additional in-field modifications.

1.7 WARRANTY

- A. General Warranty: Reference Division 01, General Requirements. Special warranties specified in this Article shall not deprive Owner of other rights Owner may have under other provisions of the Contract Documents and shall be in addition to, and run concurrent with, other warranties made by Contractor under requirements of the Contract Documents.
- B. Warranty Period: Written warranty, executed by manufacturer(s), agreeing to repair or replace components of standard and electrified door hardware that fails in materials or

workmanship within specified warranty period after final acceptance by the Owner. Failures include, but are not limited to, the following:

1. Structural failures including excessive deflection, cracking, or breakage.
 2. Faulty operation of the hardware.
 3. Deterioration of metals, metal finishes, and other materials beyond normal weathering.
 4. Electrical component defects and failures within the systems operation.
- C. Standard Warranty Period: One year from date of Substantial Completion, unless otherwise indicated.
- D. Special Warranty Periods:
1. Ten years for mortise locks and latches.
 2. Five years for exit hardware.
 3. Twenty five years for manual overhead door closer bodies.
 4. Five years for motorized electric latch retraction exit devices.
 5. Two years for electromechanical door hardware.

1.8 MAINTENANCE SERVICE

- A. Maintenance Tools and Instructions: Furnish a complete set of specialized tools and maintenance instructions as needed for Owner's continued adjustment, maintenance, and removal and replacement of door hardware.

PART 2 - PRODUCTS

2.1 SCHEDULED DOOR HARDWARE

- A. General: Provide door hardware for each door to comply with requirements in Door Hardware Sets and each referenced section that products are to be supplied under.
- B. Designations: Requirements for quantity, item, size, finish or color, grade, function, and other distinctive qualities of each type of door hardware are indicated in the Door Hardware Sets at the end of Part 3. Products are identified by using door hardware designations, as follows:
1. Named Manufacturer's Products: Product designation and manufacturer are listed for each door hardware type required for the purpose of establishing requirements. Manufacturers' names are abbreviated in the Door Hardware Schedule.
- C. Substitutions: Requests for substitution and product approval for inclusive mechanical and electromechanical door hardware in compliance with the specifications must be submitted in writing and in accordance with the procedures and time frames outlined in

Division 01, Substitution Procedures. Approval of requests is at the discretion of the architect, owner, and their designated consultants.

2.2 HANGING DEVICES

- A. Hinges: ANSI/BHMA A156.1 certified butt hinges with number of hinge knuckles and other options as specified in the Door Hardware Sets.
1. Quantity: Provide the following hinge quantity:
 - a. Two Hinges: For doors with heights up to 60 inches.
 - b. Three Hinges: For doors with heights 61 to 90 inches.
 - c. Four Hinges: For doors with heights 91 to 120 inches.
 - d. For doors with heights more than 120 inches, provide 4 hinges, plus 1 hinge for every 30 inches of door height greater than 120 inches.
 2. Hinge Size: Provide the following, unless otherwise indicated, with hinge widths sized for door thickness and clearances required:
 - a. 5" heavy weight anchor hinges, , ball bearing or oil impregnated bearing.
 3. Hinge Options: Comply with the following:
 - a. Non-removable Pins: With the exception of electric through wire hinges, provide set screw in hinge barrel that, when tightened into a groove in hinge pin, prevents removal of pin while door is closed; for the all out-swinging lockable doors.
 4. Manufacturers:
 - a. Bommer Industries (BO).
 - b. Hager Companies (HA).
 - c. McKinney Products; ASSA ABLOY Architectural Door Accessories (MK).
- B. Continuous Geared Hinges: ANSI/BHMA A156.26 Grade 1-600 certified continuous geared hinge. with minimum 0.120-inch thick extruded 6060 T6 aluminum alloy hinge leaves and a minimum overall width of 4 inches. Hinges are non-handed, reversible and fabricated to template screw locations. Factory trim hinges to suit door height and prepare for electrical cut-outs. Provide custom screw pattern where required by door manufacturer.
1. Manufacturers:
 - a. Bommer Industries (BO).
 - b. Hager Companies (HA).
 - c. Pemko Products; ASSA ABLOY Architectural Door Accessories (PE).

2.3 POWER TRANSFER DEVICES

A. Concealed Quick Connect Electric Power Transfers: Provide concealed wiring pathway housing mortised into the door and frame for low voltage electrified door hardware. Furnish with Molex™ standardized plug connectors and sufficient number of concealed wires (up to 12) to accommodate the electrified functions specified in the Door Hardware Sets. Connectors plug directly to through-door wiring harnesses for connection to electric locking devices and power supplies. Wire nut connections are not acceptable.

1. Manufacturers:

- a. Pemko Products; ASSA ABLOY Architectural Door Accessories (PE) - EL-CEPT Series.
- b. Securitron (SU) - EL-CEPT Series.

B. Electric Door Wire Harnesses: Provide electric/data transfer wiring harnesses with standardized plug connectors to accommodate up to twelve (12) wires. Connectors plug directly to through-door wiring harnesses for connection to electric locking devices and power supplies. Provide sufficient number and type of concealed wires to accommodate electric function of specified hardware. Provide a connector for through-door electronic locking devices and from hinge to junction box above the opening. Wire nut connections are not acceptable. Determine the length required for each electrified hardware component for the door type, size and construction, minimum of two per electrified opening.

1. Provide one each of the following tools as part of the base bid contract:

- a. McKinney Products; ASSA ABLOY Architectural Door Accessories (MK) - Electrical Connecting Kit: QC-R001.
- b. McKinney Products; ASSA ABLOY Architectural Door Accessories (MK) - Connector Hand Tool: QC-R003.

2. Manufacturers:

- a. Hager Companies (HA) - Quick Connect.
- b. McKinney Products; ASSA ABLOY Architectural Door Accessories (MK) - QC-C Series.

2.4 DOOR OPERATING TRIM

A. Flush Bolts and Surface Bolts: ANSI/BHMA A156.3 and A156.16, Grade 1, certified.

1. Flush bolts to be furnished with top rod of sufficient length to allow bolt retraction device location approximately six feet from the floor.
2. Furnish dust proof strikes for bottom bolts.
3. Surface bolts to be minimum 8" in length and U.L. listed for labeled fire doors and U.L. listed for windstorm components where applicable.

4. Provide related accessories (mounting brackets, strikes, coordinators, etc.) as required for appropriate installation and operation.
 5. Manufacturers:
 - a. Door Controls International (DC).
 - b. Rockwood Products; ASSA ABLOY Architectural Door Accessories (RO).
 - c. Trimco (TC).
- B. Door Push Plates and Pulls: ANSI/BHMA A156.6 certified door pushes and pulls of type and design specified in the Hardware Sets. Coordinate and provide proper width and height as required where conflicting hardware dictates.
1. Push/Pull Plates: Minimum .050 inch thick, size as indicated in hardware sets, with beveled edges, secured with exposed screws unless otherwise indicated.
 2. Door Pull and Push Bar Design: Size, shape, and material as indicated in the hardware sets. Minimum clearance of 2 1/2-inches from face of door unless otherwise indicated.
 3. Offset Pull Design: Size, shape, and material as indicated in the hardware sets. Minimum clearance of 2 1/2-inches from face of door and offset of 90 degrees unless otherwise indicated.
 4. Fasteners: Provide manufacturer's designated fastener type as indicated in Hardware Sets.
 5. Manufacturers:
 - a. Hiawatha, Inc. (HI).
 - b. Rockwood Products; ASSA ABLOY Architectural Door Accessories (RO).
 - c. Trimco (TC).

2.5 CYLINDERS AND KEYING

- A. General: Cylinder manufacturer to have minimum (10) years experience designing secured master key systems and have on record a published security keying system policy.
- B. Source Limitations: Obtain each type of keyed cylinder and keys from the same source manufacturer as locksets and exit devices, unless otherwise indicated.
 1. Manufacturers:
 - a. Corbin Russwin Hardware (RU).
 - b. Sargent Manufacturing (SA).
- C. Cylinder Types: Original manufacturer cylinders able to supply the following cylinder formats and types:
 1. Threaded mortise cylinders with rings and cams to suit hardware application.

2. Rim cylinders with back plate, flat-type vertical or horizontal tailpiece, and raised trim ring.
 3. Bored or cylindrical lock cylinders with tailpieces as required to suit locks.
 4. Tubular deadlocks and other auxiliary locks.
 5. Mortise and rim cylinder collars to be solid and recessed to allow the cylinder face to be flush and be free spinning with matching finishes.
 6. Keyway: Match Facility Standard.
- D. Removable Cores: Provide removable cores as specified, core insert, removable by use of a special key, and for use with only the core manufacturer's cylinder and door hardware.
- E. Patented Cylinders: ANSI/BHMA A156.5, Grade 1 Certified Products Directory (CPD) listed cylinders employing a utility patented and restricted keyway requiring the use of a patented key. Cylinders are to be protected from unauthorized manufacture and distribution by manufacturer's United States patents. Cylinders are to be factory keyed with owner having the ability for on-site original key cutting.
1. Patented key systems shall not be established with products that have an expired patent. Expired systems shall only be specified and supplied to support existing systems.
 2. Manufacturers:
 - a. Medeco (MC) – X4 (Exterior).
 - b. Corbin Russwin – CR8000 (Interior).
 - c. No Substitution.
- F. Keying System: Each type of lock and cylinders to be factory keyed.
1. Supplier shall conduct a "Keying Conference" to define and document keying system instructions and requirements.
 2. Furnish factory cut, nickel-silver large bow permanently inscribed with a visual key control number as directed by Owner.
 3. Existing System: Field verify and key cylinders to match Owner's existing system.
- G. Key Quantity: Provide the following minimum number of keys:
1. Change Keys per Cylinder: Three (3).
 2. Master Keys (per Master Key Level/Group): Five (5).
 3. Construction Keys (where required): Ten (10).
 4. Construction Control Keys (where required): Two (2).
 5. Permanent Control Keys (where required): Two (2).
- H. Construction Keying: Provide construction master keyed cylinders.
- I. Construction Keying: Provide temporary keyed construction cores.
- J. Key Registration List (Bitting List):

1. Provide keying transcript list to Owner's representative in the proper format for importing into key control software.
2. Provide transcript list in writing or electronic file as directed by the Owner.

2.6 KEY CONTROL

- A. Key Control Cabinet: Provide a key control system including envelopes, labels, and tags with self-locking key clips, receipt forms, 3-way visible card index, temporary markers, permanent markers, and standard metal cabinet. Key control cabinet shall have expansion capacity of 150% of the number of locks required for the project.
 1. Manufacturers:
 - a. Lund Equipment (LU).
 - b. MMF Industries (MM).
 - c. Telkee (TK).

2.7 MECHANICAL LOCKS AND LATCHING DEVICES

- A. Mortise Locksets, Grade 1 (Heavy Duty): ANSI/BHMA A156.13, Series 1000, Operational Grade 1 Certified Products Directory (CPD) listed. Locksets are to be manufactured with a corrosion resistant steel case and be field-reversible for handing without disassembly of the lock body.
 1. Where specified, provide status indicators with highly reflective color and wording for "locked/unlocked" or "vacant/occupied" with custom wording options if required. Indicator to be located above the cylinder with the inside thumb-turn not blocking the visibility of the indicator status. Indicator window size to be a minimum of 2.1" x 0.6" with a curved design allowing a 180 degree viewing angle with protective covering to prevent tampering.
 2. Manufacturers:
 - a. Corbin Russwin Hardware (RU) - ML2000 Series.

2.8 ELECTROMECHANICAL LOCKING DEVICES

- A. Electromechanical Mortise Locksets, Grade 1 (Heavy Duty): ANSI/BHMA A156.13, Series 1000, Operational Grade 1 Certified Products Directory (CPD) listed, subject to same compliance standards and requirements as mechanical mortise locksets, electrified locksets to be of type and design as specified below and in the hardware sets.
 1. Electrified Lock Options: Where indicated in the Hardware Sets, provide electrified options including: outside door lock/unlock trim control, latchbolt and lock/unlock status monitoring, deadbolt monitoring, and request-to-exit signaling.

Support end-of-line resistors contained within the lock case. Unless otherwise indicated, provide electrified locksets standard as fail secure.

2. Manufacturers:
 - a. Corbin Russwin Hardware (RU) - ML20900 Series.

2.9 AUXILIARY LOCKS

- A. Mortise Deadlocks, Small Case: ANSI/BHMA A156.36, Grade 1, small case mortise type deadlocks constructed of heavy gauge wrought corrosion resistant steel. Steel or stainless steel bolts with a 1" throw and hardened steel roller pins. Deadlocks to be products of the same source manufacturer and keyway as other specified locksets.

1. Manufacturers:
 - a. Corbin Russwin Hardware (RU) - DL4000 Series.

2.10 LOCK AND LATCH STRIKES

- A. Strikes: Provide manufacturer's standard strike with strike box for each latch or lock bolt, with curved lip extended to protect frame, finished to match door hardware set, unless otherwise indicated, and as follows:

1. Flat-Lip Strikes: For locks with three-piece antifriction latchbolts, as recommended by manufacturer.
2. Extra-Long-Lip Strikes: For locks used on frames with applied wood casing trim.
3. Aluminum-Frame Strike Box: Provide manufacturer's special strike box fabricated for aluminum framing.
4. Short-lipped strikes: For locks at double doors.

- B. Standards: Comply with the following:

1. Strikes for Mortise Locks and Latches: BHMA A156.13.
2. Strikes for Bored Locks and Latches: BHMA A156.2.
3. Strikes for Auxiliary Deadlocks: BHMA A156.36.
4. Dustproof Strikes: BHMA A156.16.

2.11 CONVENTIONAL EXIT DEVICES

- A. General Requirements: All exit devices specified herein shall meet or exceed the following criteria:

1. At doors not requiring a fire rating, provide devices complying with NFPA 101 and listed and labeled for "Panic Hardware" according to UL305. Provide proper fasteners as required by manufacturer including sex nuts and bolts at openings specified in the Hardware Sets.

2. Where exit devices are required on fire rated doors, provide devices complying with NFPA 80 and with UL labeling indicating "Fire Exit Hardware". Provide devices with the proper fasteners for installation as tested and listed by UL. Consult manufacturer's catalog and template book for specific requirements.
 3. Except on fire rated doors, provide exit devices with key cylinder dogging device to hold the pushbar and latch in a retracted position.
 4. Devices must fit flat against the door face with no gap that permits unauthorized dogging of the push bar. The addition of filler strips is required in any case where the door light extends behind the device as in a full glass configuration.
 5. Flush End Caps: Provide flush end caps made of architectural metal in the same finish as the devices as in the Hardware Sets. Plastic end caps will not be acceptable.
 6. Lever Operating Trim: Where exit devices require lever trim, furnish manufacturer's heavy duty escutcheon trim with threaded studs for thru-bolts.
 - a. Lock Trim Design: As indicated in Hardware Sets, provide finishes and designs to match that of the specified locksets.
 - b. Where function of exit device requires a cylinder, provide a cylinder (Rim or Mortise) as specified in Hardware Sets.
 7. Vertical Rod Exit Devices: Where surface or concealed vertical rod exit devices are used at interior openings, provide as less bottom rod (LBR) unless otherwise indicated. Provide dust proof strikes where thermal pins are required to project into the floor.
 8. Narrow Stile Applications: At doors constructed with narrow stiles, or as specified in Hardware Sets, provide devices designed for maximum 2" wide stiles.
 9. Dummy Push Bar: Nonfunctioning push bar matching functional push bar.
 10. Extended cycle test: Devices to have been cycle tested to 9 million cycles.
 11. Rail Sizing: Provide exit device rails factory sized for proper door width application.
 12. Through Bolt Installation: For exit devices and trim as indicated in Door Hardware Sets.
- B. Conventional Push Rail Exit Devices (Heavy Duty): ANSI/BHMA A156.3, Grade 1 Certified Products Directory (CPD) listed panic and fire exit hardware devices furnished in the functions specified in the Hardware Sets. Exit device latch to be stainless steel, pullman type, with deadlock feature.
1. Manufacturers:
 - a. Sargent Manufacturing (SA) - 80 Series.

2.12 ELECTROMECHANICAL EXIT DEVICES

- A. Electromechanical Push Rail Exit Devices (Heavy Duty): ANSI/BHMA A156.3, Grade 1 Certified Products Directory (CPD) listed panic and fire exit hardware devices subject to same compliance standards and requirements as mechanical exit devices. Electrified exit devices to be of type and design as specified below and in the hardware sets.
1. Where conventional power supplies are not sufficient, include any specific controllers required to provide the proper inrush current.
 2. Motorized Electric Latch Retraction: Devices with an electric latch retraction feature must use motors which have a maximum current draw of 600mA. Solenoid driven latch retraction is not acceptable.
 3. Manufacturers:
 - a. Sargent Manufacturing (SA) - 80 Series.
- B. Tube Steel Removable Mullions: ANSI/BHMA A156.3 removable steel mullions with malleable-iron top and bottom retainers and a primed paint finish.
1. Provide keyed removable feature where specified in the Hardware Sets.
 2. Provide stabilizers and mounting brackets as required.
 3. Manufacturers:
 - a. Same as exit device manufacturer.

2.13 DOOR CLOSERS

- A. All door closers specified herein shall meet or exceed the following criteria:
1. General: Door closers to be from one manufacturer, matching in design and style, with the same type door preparations and templates regardless of application or spring size. Closers to be non-handed with full sized covers.
 2. Standards: Closers to comply with UL-10C for Positive Pressure Fire Test and be U.L. listed for use of fire rated doors.
 3. Cycle Testing: Provide closers which have surpassed 15 million cycles.
 4. Size of Units: Comply with manufacturer's written recommendations for sizing of door closers depending on size of door, exposure to weather, and anticipated frequency of use. Where closers are indicated for doors required to be accessible to the Americans with Disabilities Act, provide units complying with ANSI ICC/A117.1.
 5. Closer Arms: Provide heavy duty, forged steel closer arms unless otherwise indicated in Hardware Sets.

6. Closers shall not be installed on exterior or corridor side of doors; where possible install closers on door for optimum aesthetics.
 7. Closer Accessories: Provide door closer accessories including custom templates, special mounting brackets, spacers and drop plates as required for proper installation. Provide through-bolt and security type fasteners as specified in the hardware sets.
- B. Door Closers, Surface Mounted (Unitrol): ANSI/BHMA A156.4, Grade 1 Certified Products Directory (CPD) listed surface mounted closers with door stop mechanism to absorb dead stop shock on arm and top hinge. Hold-open arms to have a spring loaded mechanism in addition to shock absorber assembly. Arms to be provided with rigid steel main arm and secondary arm lengths proportional to the door width.
1. Manufacturers:
 - a. Norton Door Controls (NO) - Unitrol Series.
- C. Door Closers, Surface Mounted (Commercial Duty): ANSI/BHMA 156.4, Grade 1 Certified Products Directory (CPD) listed surface mounted, institutional grade door closers with complete spring power adjustment, sizes 1 thru 6; and fully operational adjustable according to door size, frequency of use, and opening force. Closers to be rack and pinion type, one piece cast iron or aluminum alloy body construction, with adjustable backcheck, closing sweep, and latch speed control valves. Provide non-handed units standard.
1. Manufacturers:
 - a. Corbin Russwin Hardware (RU) - DC6000 Series.

2.14 SURFACE MOUNTED CLOSER HOLDERS

- A. Electromagnetic Door Holders: Certified ANSI A156.15 electromagnetic door holder/releases with a minimum 20 to 40 pounds holding power and single coil construction able to accommodate 12VDC, 24VAC, 24VDC and 120VAC. Coils to be independently wound, employing an integral fuse and armatures to include a positive release button.
1. Manufacturers:
 - a. Rixson (RF) - 980/990 Series.
 - b. Sargent Manufacturing (SA) - 1560 Series.

2.15 ARCHITECTURAL TRIM

- A. Door Protective Trim

1. General: Door protective trim units to be of type and design as specified below or in the Hardware Sets.
2. Size: Fabricate protection plates (kick, armor, or mop) not more than 2" less than door width (LDW) on stop side of single doors and 1" LDW on stop side of pairs of doors, and not more than 1" less than door width on pull side. Coordinate and provide proper width and height as required where conflicting hardware dictates. Height to be as specified in the Hardware Sets.
3. Where plates are applied to fire rated doors with the top of the plate more than 16" above the bottom of the door, provide plates complying with NFPA 80. Consult manufacturer's catalog and template book for specific requirements for size and applications.
4. Protection Plates: ANSI/BHMA A156.6 certified protection plates (kick, armor, or mop), fabricated from the following:
 - a. Stainless Steel: 300 grade, 050-inch thick.
5. Options and fasteners: Provide manufacturer's designated fastener type as specified in the Hardware Sets. Provide countersunk screw holes.
6. Manufacturers:
 - a. Hiawatha, Inc. (HI).
 - b. Rockwood Products; ASSA ABLOY Architectural Door Accessories (RO).
 - c. Trimco (TC).

2.16 DOOR STOPS AND HOLDERS

- A. General: Door stops and holders to be of type and design as specified below or in the Hardware Sets.
- B. Door Stops and Bumpers: ANSI/BHMA A156.16, Grade 1 certified door stops and wall bumpers. Provide wall bumpers, either convex or concave types with anchorage as indicated, unless floor or other types of door stops are specified in Hardware Sets. Do not mount floor stops where they will impede traffic. Where floor or wall bumpers are not appropriate, provide Rixson 9 Series overhead type stops and holders.
 1. Manufacturers:
 - a. Hiawatha, Inc. (HI).
 - b. Rockwood Products; ASSA ABLOY Architectural Door Accessories (RO).
 - c. Trimco (TC).

2.17 ARCHITECTURAL SEALS

- A. General: Thresholds, weatherstripping, and gasket seals to be of type and design as specified below or in the Hardware Sets. Provide continuous weatherstrip gasketing on exterior doors and provide smoke, light, or sound gasketing on interior doors where indicated. At exterior applications provide non-corrosive fasteners and elsewhere where indicated.
- B. Smoke Labeled Gasketing: Assemblies complying with NFPA 105 that are listed and labeled by a testing and inspecting agency acceptable to authorities having jurisdiction, for smoke control ratings indicated, based on testing according to UL 1784.
 - 1. Provide smoke labeled perimeter gasketing at all smoke labeled openings.
- C. Fire Labeled Gasketing: Assemblies complying with NFPA 80 that are listed and labeled by a testing and inspecting agency acceptable to authorities having jurisdiction, for fire ratings indicated, based on testing according to UL-10C.
 - 1. Provide intumescent seals as indicated to meet UL10C Standard for Positive Pressure Fire Tests of Door Assemblies, and NPFA 252, Standard Methods of Fire Tests of Door Assemblies.
- D. Sound-Rated Gasketing: Assemblies that are listed and labeled by a testing and inspecting agency, for sound ratings indicated.
- E. Replaceable Seal Strips: Provide only those units where resilient or flexible seal strips are easily replaceable and readily available from stocks maintained by manufacturer.
- F. Manufacturers:
 - 1. National Guard Products (NG).
 - 2. Pemko Products; ASSA ABLOY Architectural Door Accessories (PE).
 - 3. Reese Enterprises, Inc. (RE).

2.18 ELECTRONIC ACCESSORIES

- A. Switching Power Supplies: Provide power supplies with either single or dual voltage configurations at 12 or 24VDC. Power supplies shall have battery backup function with an integrated battery charging circuit and shall provide capability for power distribution, direct lock control and Fire Alarm Interface (FAI) through add on modules. Power supplies shall be expandable up to 16 individually protected outputs. Output modules shall provide individually protected, continuous outputs and/or individually protected, relay controlled outputs.
 - 1. Provide the least number of units, at the appropriate amperage level, sufficient to exceed the required total draw for the specified electrified hardware and access control equipment.
 - 2. Manufacturers:

- a. Securitron (SU) - AQD Series.

2.19 FABRICATION

- A. Fasteners: Provide door hardware manufactured to comply with published templates generally prepared for machine, wood, and sheet metal screws. Provide screws according to manufacturers recognized installation standards for application intended.

2.20 FINISHES

- A. Standard: Designations used in the Hardware Sets and elsewhere indicate hardware finishes complying with ANSI/BHMA A156.18, including coordination with traditional U.S. finishes indicated by certain manufacturers for their products.
- B. Provide quality of finish, including thickness of plating or coating (if any), composition, hardness, and other qualities complying with manufacturer's standards, but in no case less than specified by referenced standards for the applicable units of hardware
- C. Protect mechanical finishes on exposed surfaces from damage by applying a strippable, temporary protective covering before shipping.

PART 3 - EXECUTION

3.1 EXAMINATION

- A. Examine scheduled openings, with Installer present, for compliance with requirements for installation tolerances, labeled fire door assembly construction, wall and floor construction, and other conditions affecting performance.
- B. Notify architect of any discrepancies or conflicts between the door schedule, door types, drawings and scheduled hardware. Proceed only after such discrepancies or conflicts have been resolved in writing.

3.2 PREPARATION

- A. Hollow Metal Doors and Frames: Comply with ANSI/DHI A115 series.
- B. Wood Doors: Comply with ANSI/DHI A115-W series.

3.3 INSTALLATION

- A. Install each item of mechanical and electromechanical hardware and access control equipment to comply with manufacturer's written instructions and according to specifications.

1. Installers are to be trained and certified by the manufacturer on the proper installation and adjustment of fire, life safety, and security products including: hanging devices; locking devices; closing devices; and seals.
- B. Mounting Heights: Mount door hardware units at heights indicated in following applicable publications, unless specifically indicated or required to comply with governing regulations:
 1. Standard Steel Doors and Frames: DHI's "Recommended Locations for Architectural Hardware for Standard Steel Doors and Frames."
 2. Wood Doors: DHI WDHS.3, "Recommended Locations for Architectural Hardware for Wood Flush Doors."
 3. Where indicated to comply with accessibility requirements, comply with ANSI A117.1 "Accessibility Guidelines for Buildings and Facilities."
 4. Provide blocking in drywall partitions where wall stops or other wall mounted hardware is located.
- C. Retrofitting: Install door hardware to comply with manufacturer's published templates and written instructions. Where cutting and fitting are required to install door hardware onto or into surfaces that are later to be painted or finished in another way, coordinate removal, storage, and reinstallation of surface protective trim units with finishing work specified in Division 9 Sections. Do not install surface-mounted items until finishes have been completed on substrates involved.
- D. Thresholds: Set thresholds for exterior and acoustical doors in full bed of sealant complying with requirements specified in Division 7 Section "Joint Sealants."
- E. Storage: Provide a secure lock up for hardware delivered to the project but not yet installed. Control the handling and installation of hardware items so that the completion of the work will not be delayed by hardware losses before and after installation.

3.4 ADJUSTING

- A. Initial Adjustment: Adjust and check each operating item of door hardware and each door to ensure proper operation or function of every unit. Replace units that cannot be adjusted to operate as intended. Adjust door control devices to compensate for final operation of heating and ventilating equipment and to comply with referenced accessibility requirements.

3.5 CLEANING AND PROTECTION

- A. Protect all hardware stored on construction site in a covered and dry place. Protect exposed hardware installed on doors during the construction phase. Install any and all hardware at the latest possible time frame.
- B. Clean adjacent surfaces soiled by door hardware installation.

- C. Clean operating items as necessary to restore proper finish. Provide final protection and maintain conditions that ensure door hardware is without damage or deterioration at time of owner occupancy.

3.6 DEMONSTRATION

- A. Instruct Owner's maintenance personnel to adjust, operate, and maintain mechanical and electromechanical door hardware.

3.7 DOOR HARDWARE SETS

- A. The hardware sets represent the design intent and direction of the owner and architect. They are a guideline only and should not be considered a detailed hardware schedule. Discrepancies, conflicting hardware and missing items should be brought to the attention of the architect with corrections made prior to the bidding process. Omitted items not included in a hardware set should be scheduled with the appropriate additional hardware required for proper application and functionality.

1. Quantities listed are for each pair of doors, or for each single door.
2. The supplier is responsible for handing and sizing all products.
3. Where multiple options for a piece of hardware are given in a single line item, the supplier shall provide the appropriate application for the opening.

- B. Manufacturer's Abbreviations:

1. MK - McKinney
2. PE - Pemko
3. RO - Rockwood
4. SA - SARGENT
5. RU - Corbin Russwin
6. AD - Adams Rite
7. MC - Medeco
8. HS - HES
9. NO - Norton
10. RF - Rixson
11. SU - Securitron

Hardware Sets

Set: 1.0

Description: Exterior Alum Pair - Card Access

2	Continuous Hinge	CFM-HD1 Series EL-CEPTx32D	PE
1	Key Removable Mullion	L980S	PC SA

1	Exit Device (rim, NL, EL, CD)	16 43 56 64 8804	US32D	SA
1	Exit Device (rim, EL, CD)	16 43 56 64 8810	US32D	SA
2	Pull (offset)	862	US32D	SA
4	Removable X4 Core (exterior)	322401-N (to fit Sargent LFIC)	26	MC
1	Mullion Cylinder	64 980C1	US26D	SA
2	Door Closer (HD stop)	UNI7500 M	689	NO
1	Threshold (coord w/ details)	273x292AFGPK FHSL14SS		PE
1	Mullion Gasket	5110BL		PE
2	Door Wiring Harness	QC Series (hinge to device)		MK
2	Frame Wiring Harness	QC Series (jamb to J-box)		MK
1	Power Supply	AQD4 Series (coord w/ security)		SU
1	Remote Control Switch	By Security Vendor		
2	DPS & REX Devices	By Security Vendor		
1	Weather Seals	Supplied with door/frame assembly		
1	Card Reader	By Security Vendor		

Notes:

Operation: Door is normally closed and locked. Valid card at reader or signal from remote switch retracts latch for momentary access. Monitoring by door position switches. During a loss of power the door will default to secure. Free egress at all times. Lock status will not change when the fire detection / suppression systems are activated. Approaching door on egress side will activate request to exit switch for appropriate monitor by EAC systems. Outside key override.

Set: 1.1

Description: Exterior; Vestibule Alum Pair - Card Access; Auto

2	Continuous Hinge	CFM-HD1 Series EL-CEPTx32D		PE
1	Key Removable Mullion	L980S	PC	SA
1	Exit Device (rim, NL, EL, LX, CD)	16 43 53 56 64 8804	US32D	SA
1	Exit Device (rim, EL, LX,CD)	16 43 53 56 64 8810	US32D	SA
2	Pull (offset)	862	US32D	SA
1	Removable X4 Core (exterior)	322401-N (to fit Sargent LFIC)	26	MC
1	Mullion Cylinder	64 980C1	US26D	SA
1	Door Closer (HD stop, TJ)	UNI7500 M	689	NO
1	Automatic Opener	6061; 6071 D	689	NO
1	Threshold (coord w/ details)	273x292AFGPK FHSL14SS		PE
1	Mullion Gasket	5110BL		PE
2	Door Wiring Harness	QC Series (hinge to device)		MK
2	Frame Wiring Harness	QC Series (jamb to J-box)		MK
2	Door Switch	501		NO
1	Power Supply	AQD4 Series (coord w/ security)		SU
1	Remote Control Switch	By Security Vendor		
2	DPS & REX Devices	By Security Vendor		
1	Weather Seals	Supplied with door/frame assembly		
1	Card Reader	By Security Vendor		

Notes:

Operation: Doors are normally closed and locked. Valid card at reader or signal from remote switch retracts latch for momentary access, then enables outside actuator. Inside actuator

retracts latch, then auto opens one door. Monitoring by door position switch. During a loss of power the door will default to secure. Free egress at all times. Lock status will not change when the fire detection/suppression systems are activated. Approaching door on egress side will activate request to exit switch for appropriate monitor by EAC systems. Outside key override.

Set: 2.0

Description: Exterior Alum Pair

2	Continuous Hinge	CFM-HD1 Series		PE
1	Key Removable Mullion	L980S	PC	SA
1	Exit Device (rim, CD)	16 43 64 8810	US32D	SA
1	Exit Device (rim, NL, CD)	16 43 64 8804	US32D	SA
2	Pull (offset)	862	US32D	SA
4	Removable X4 Core (exterior)	322401-N (to fit Sargent LFIC)	26	MC
1	Mullion Cylinder	64 980C1	US26D	SA
2	Door Closer (HD stop)	UNI7500 M	689	NO
1	Threshold (coord w/ details)	273x292AFGPK FHSL14SS		PE
1	Mullion Gasket	5110BL		PE
2	Position Switch (concealed)	By Security Vendor		SU
1	Weather Seals	Supplied with door/frame assembly		

Set: 3.0

Description: Exterior; Vestibule Alum - Card Access

1	Continuous Hinge	CFM-HD1 Series EL-CEPTx32D		PE
1	Exit Device (rim, NL, EL, CD)	16 43 56 64 8804	US32D	SA
1	Pull (offset)	862	US32D	SA
2	Removable X4 Core (exterior)	322401-N (to fit Sargent LFIC)	26	MC
1	Door Closer (HD stop)	UNI7500 M	689	NO
1	Threshold (coord w/ details)	273x292AFGPK FHSL14SS		PE
1	Door Wiring Harness	QC Series (hinge to device)		MK
1	Frame Wiring Harness	QC Series (jamb to J-box)		MK
1	Power Supply	AQD4 Series (coord w/ security)		SU
1	Remote Control Switch	By Security Vendor		
1	DPS & REX Devices	By Security Vendor		
1	Weather Seals	Supplied with door/frame assembly		
1	Card Reader	By Security Vendor		

Notes: Owner to confirm which cylinder/core is used for vestibule doors (typ).

Operation: Door is normally closed and locked. Valid card at reader or signal from remote switch retracts latch for momentary access. Monitoring by door position switch. During a loss of power the door will default to secure. Free egress at all times. Lock status will not change when the fire detection / suppression systems are activated. Approaching door on egress side will activate request to exit switch for appropriate monitor by EAC systems. Outside key override.

Set: 3.1

Description: Exterior; Vestibule Alum - Card Access; Auto

1	Continuous Hinge	CFM-HD1 Series EL-CEPTx32D		PE
1	Exit Device (rim, NL, EL, LX, CD)	16 43 53 56 64 8804	US32D	SA
1	Pull (offset)	862	US32D	SA
2	Removable X4 Core (exterior)	322401-N (to fit Sargent LFIC)	26	MC
1	Automatic Opener	6061; 6071 D	689	NO
1	Threshold (coord w/ details)	273x292AFGPK FHSL14SS		PE
1	Door Wiring Harness	QC Series (hinge to device)		MK
1	Frame Wiring Harness	QC Series (jamb to J-box)		MK
2	Door Switch	501		NO
1	Power Supply	AQD4 Series (coord w/ security)		SU
1	Remote Control Switch	By Security Vendor		
1	DPS & REX Devices	By Security Vendor		
1	Weather Seals	Supplied with door/frame assembly		
1	Card Reader	By Security Vendor		

Notes: Owner to confirm which cylinder/core is used for vestibule doors (typ).

Operation: Door is normally closed and locked. Valid card at reader or signal from remote switch retracts latch for momentary access, then enables outside actuator. Inside actuator unlatches, then auto opens door. Monitoring by door position switch. During a loss of power the door will default to secure. Free egress at all times. Lock status will not change when the fire detection / suppression systems are activated. Approaching door on egress side will activate request to exit switch for appropriate monitor by EAC systems. Outside key override.

Set: 4.0

Description: Exterior; Vestibule Alum at Main Entrance

1	Continuous Hinge	CFM-HD1 Series		PE
1	Exit Device (rim, CD)	16 43 64 8810	US32D	SA
1	Pull (offset)	862	US32D	SA
1	Removable X4 Core (exterior)	322401-N (to fit Sargent LFIC)	26	MC
1	Door Closer (HD stop)	UNI7500 M	689	NO
1	Threshold (coord w/ details)	273x292AFGPK FHSL14SS		PE
1	Position Switch (concealed)	By Security Vendor		SU
1	Weather Seals	Supplied with door/frame assembly		

Notes: Provide door position switches for exterior doors (coordinate w/ security).

Set: 5.0

Description: Alum Vestibule Pair

2	Continuous Hinge	CFM-HD1 Series		PE
1	Key Removable Mullion	L980S	PC	SA
1	Exit Device (rim, CD)	16 43 64 8810	US32D	SA
1	Exit Device (rim, NL, CD)	16 43 64 8804	US32D	SA
2	Pull (offset)	862	US32D	SA
4	Removable X4 Core (exterior)	322401-N (to fit Sargent LFIC)	26	MC
1	Mullion Cylinder	64 980C1	US26D	SA
2	Surface Closer (interior)	DC6200 A10 or DC6210 A3; M73	689	RU

2	Door Stop RO	404 Wall; 441CU Floor (or per spec)	US26D
1	Threshold (coord w/ details)	271A FHSL14SS	PE
1	Mullion Gasket	5110BL	PE
1	Weather Seals	Supplied with door/frame assembly	

Notes: Owner to confirm which cylinder/core is used for vestibule doors.

Set: 6.0

Description: Exterior FRP Pair - Card Access

1	Continuous Hinge	CFM-HD1 Series EL-CEPTx32D	PE
1	Continuous Hinge	CFM-HD1 Series	PE
1	Key Removable Mullion	L980S	PC SA
1	Exit Device (rim, DT, CD)	16 43 8810 ETP	US32D SA
1	Exit Device (rim,NL,EL,CD)	16 43 56 64 8804 ETP	US32D SA
4	Removable X4 Core (exterior)	322401-N (to fit Sargent LFIC)	26 MC
1	Mullion Cylinder	64 980C1	US26D SA
2	Door Closer (HD stop)	UNI7500 M	689 NO
1	Threshold (coord w/ details)	273x292AFGPK FHSL14SS	PE
1	Mullion Gasket	5110BL	PE
2	Sweep	315CN	PE
2	Astragal	305CN	PE
1	Door Wiring Harness	QC Series (hinge to device)	MK
1	Frame Wiring Harness	QC Series (jamb to J-box)	MK
1	Power Supply	AQD4 Series (coord w/ security)	SU
2	DPS & REX Devices	By Security Vendor	
1	Weather Seals	Supplied with door/frame assembly	
1	Card Reader	By Security Vendor	

Notes:

Operation: Door is normally closed and locked. Valid card at reader retracts latch for momentary access. Monitoring by door position switches. During a loss of power the door will default to secure. Free egress at all times. Lock status will not change when the fire detection / suppression systems are activated. Approaching door on egress side will activate request to exit switch for appropriate monitor by EAC systems. Outside key override.

Set: 7.0

Description: Exterior FRP Pair - Loading

2	Continuous Hinge	CFM-HD1 Series	PE
1	Dust Proof Strike	570	US26D RO
2	Flush Bolt (manual)	555	US26D RO
1	Storeroom Lock	ML2057 PSA LFIC	626 RU
1	Removable X4 Core (exterior)	322401-N (to fit Sargent LFIC)	26 MC
1	Cylinder (Corbin exterior devices)	LFIC to suit device	US15 SA
2	Door Closer (HD stop, hold open)	UNI7500H M	689 NO
1	Threshold (coord w/ details)	1716AK FHSL14SS	PE
2	Sweep	315CN	PE

1	Astragal	355CPK		PE
2	Position Switch (concealed)	By Security Vendor		SU
1	Weather Seals	Supplied with door/frame assembly		

Set: 8.0

Description: Exterior FRP - Card Access

1	Continuous Hinge	CFM-HD1 Series EL-CEPTx32D		PE
1	Exit Device (rim,NL,EL,CD)	16 43 56 64 8804 ETP	US32D	SA
2	Removable X4 Core (exterior)	322401-N (to fit Sargent LFIC)	26	MC
1	Door Closer (HD stop)	UNI7500 M	689	NO
1	Threshold (coord w/ details)	273x292AFGPK FHSL14SS		PE
1	Sweep	315CN		PE
1	Door Wiring Harness	QC Series (hinge to device)		MK
1	Frame Wiring Harness	QC Series (jamb to J-box)		MK
1	Power Supply	AQD4 Series (coord w/ security)		SU
1	DPS & REX Devices	By Security Vendor		
1	Weather Seals	Supplied with door/frame assembly		
1	Card Reader	By Security Vendor		

Notes:

Operation: Door is normally closed and locked. Valid card at reader retracts latch for momentary access. Monitoring by door position switches. During a loss of power the door will default to secure. Free egress at all times. Lock status will not change when the fire detection / suppression systems are activated. Approaching door on egress side will activate request to exit switch for appropriate monitor by EAC systems. Outside key override.

Set: 9.0

Description: Exterior FRP Loading - Card Access

1	Continuous Hinge	CFM-HD1 Series EL-CEPTx32D		PE
1	Mortise Lock (fail-secure)	ML20906-SEC PSA LFIC	626	RU
1	Removable X4 Core (exterior)	322401-N (to fit Sargent LFIC)	26	MC
1	Cylinder (Corbin exterior devices)	LFIC to suit device	US15	SA
1	Door Closer (HD stop)	UNI7500 M	689	NO
1	Threshold (coord w/ details)	273x292AFGPK FHSL14SS		PE
1	Sweep	315CN		PE
1	Door Wiring Harness	QC Series (hinge to device)		MK
1	Frame Wiring Harness	QC Series (jamb to J-box)		MK
1	Power Supply	AQD4 Series (coord w/ security)		SU
1	Remote Control Switch	By Security Vendor		
1	DPS & REX Devices	By Security Vendor		
1	Weather Seals	Supplied with door/frame assembly		
1	Card Reader	By Security Vendor		

Notes:

Operation: Door is normally closed and locked. Valid card at reader or signal from remote switch retracts latch for momentary access. Monitoring by door position switches. During a loss of power the door will default to secure. Free egress at all times. Lock status will not change when

the fire detection / suppression systems are activated. Approaching door on egress side will activate request to exit switch for appropriate monitor by EAC systems. Outside key override.

Set: 10.0

Description: Exterior FRP

1	Continuous Hinge	CFM-HD1 Series		PE
1	Exit Device (rim, storeroom, CD)	16 43 64 8804 ETP	US32D	SA
1	Removable X4 Core (exterior)	322401-N (to fit Sargent LFIC)	26	MC
1	Door Closer (HD stop)	UNI7500 M	689	NO
1	Threshold (coord w/ details)	273x292AFGPK FHSL14SS		PE
1	Sweep	315CN		PE
1	Position Switch (concealed)	By Security Vendor		SU
1	Weather Seals	Supplied with door/frame assembly		

Set: 11.0

Description: Exterior FRP - Roof

1	Continuous Hinge	CFM-HD1 Series		PE
1	Storeroom Lock	ML2057 PSA LFIC	626	RU
1	Removable X4 Core (exterior)	322401-N (to fit Sargent LFIC)	26	MC
1	Cylinder (Corbin exterior devices)	LFIC to suit device	US15	SA
1	Surface Closer (interior)	DC6200 A10 or DC6210 A3; M73	689	RU
1	Threshold (coord w/ details)	1716AK FHSL14SS		PE
1	Sweep	315CN		PE
1	Position Switch (concealed)	By Security Vendor		SU
1	Weather Seals	Supplied with door/frame assembly		

Notes: Free egress from roof.

Set: 12.0

Description: Corridor Pair - Card Access (both directions); Hold Open; Alarmed

2	Anchor Hinge Set, Hvy Wt	TA792 5" x 4-1/2" (qty per part 2)	US26D	MK
1	Exit Device (SVR,LBR,FSE,AL)	LD (12 if rated) 43 AL NB8774 ETP		US32D
1	Exit Device (SVR,LBR,storerm,AL)		LD (12 if rated) 43 AL	
		NB8706 ETP	US32D	SA
3	Removable Core (interior)	CR8000 Keyed to existing system	626	RU
3	Cylinder (Sargent interior devices)			LFIC to suit device
		626	RU	
2	Surface Closer (interior)	DC6200 A10 or DC6210 A3; M73	689	RU
2	Kick Plate	K1050 10" 4BE CSK	US32D	RO
2	Mop Plate	K1050 6" 4BE CSK	US32D	RO
2	Electromagnetic Holder	998M (or to suit details)	689	RF
1	Head & Jamb Seal (adhesive)	S88BL		PE
1	Astragal (adhesive, edge mount)	S772C		PE
2	Wiring Harness	546		SA
2	Frame Wiring Harness	QC Series (jamb to J-box)		MK

1	Power Supply (9V)	3267	SA
1	Power Supply	AQD4 Series (coord w/ security)	SU
2	Electric Power Transfer	EL-CEPT	SU
2	DPS & REX Devices	By Security Vendor	
2	Card Reader	By Security Vendor	

Notes: Interface with building fire alarm system to release door(s) from hold open.

Operation: Doors can be closed, locked and armed or held open. When closed, valid card at reader unlocks outside lever for momentary access or disarms alarm(s) for momentary passage. Monitoring by door position switches. During a loss of power the door will default to secure. Free (alarmed) egress at all times. Lock status will not change when the fire detection/suppression systems are activated. Approaching doors on egress side will activate request to exit switch for appropriate monitor by EAC systems. Outside key override.

Set: 12.1

Description: Vestibule Pair (Rated) - Card Access; Auto

2	Anchor Hinge Set, Hvy Wt	TA792 5" x 4-1/2" (qty per part 2)	US26D	MK
1	Key Removable Mullion	12-L980	PC	SA
1	Exit Device (rim, exit only)	12 43 8810 EO	US32D	SA
1	Exit Device (rim,NL,EL,LX)	12 43 53 56 64 8804 ETP	US32D	SA
2	Removable Core (interior)	CR8000 Keyed to existing system	626	RU
2	Cylinder (Sargent interior devices)		LFIC to suit device	
	626	RU		
1	Surface Closer (interior)	DC6200 A10 or DC6210 A3; M73	689	RU
1	Automatic Opener	6061; 6071 D	689	NO
2	Kick Plate	K1050 10" 4BE CSK	US32D	RO
2	Mop Plate	K1050 6" 4BE CSK	US32D	RO
2	Door Stop	404 Wall; 441CU Floor (or per spec)		US26D
	RO			
1	Threshold (coord w/ details)	271A FHSL14SS		PE
1	Mullion Gasket	5110BL		PE
1	Head & Jamb Seal (adhesive)	S88BL		PE
1	Astragal (adhesive, edge mount)	S772C		PE
1	Door Wiring Harness	QC Series (hinge to device)		MK
1	Frame Wiring Harness	QC Series (jamb to J-box)		MK
2	Door Switch	501		NO
1	Power Supply	AQD4 Series (coord w/ security)		SU
1	Electric Power Transfer	EL-CEPT		SU
2	DPS & REX Devices	By Security Vendor		
1	Card Reader	By Security Vendor		

Notes:

Operation: Doors are normally closed and locked. Valid card at reader retracts latch for momentary access, then enables outside actuator. Inside actuator retracts latch, then auto opens one door. Monitoring by door position switches. During a loss of power the door will default to secure. Free egress at all times. Door status will default to closed and locked when

the fire detection/suppression systems are activated. Approaching door on egress side will activate request to exit switch for appropriate monitor by EAC systems. Outside key override.

Set: 13.0

Description: Corridor; Stair Pair - Hold Open

2	Anchor Hinge Set, Hvy Wt	TA792 5" x 4-1/2" (qty per part 2)	US26D	MK
2	Exit Device (SVR,LBR,passage)	12 NB8715 ETP	US32D	SA
2	Surface Closer (interior)	DC6200 A10 or DC6210 A3; M73	689	RU
2	Kick Plate	K1050 10" 4BE CSK	US32D	RO
2	Mop Plate	K1050 6" 4BE CSK	US32D	RO
2	Electromagnetic Holder	998M (or to suit details)	689	RF
1	Head & Jamb Seal (adhesive)	S88BL		PE
1	Astragal (adhesive, edge mount)	S772C		PE

Notes: Interface with building fire alarm system to release door(s) from hold open.
Provide floor mounted magnetic holder at one leaf of door SG1a.

Set: 13.1

Description: Corridor Double Egress Pair - Hold Open

2	Anchor Hinge Set, Hvy Wt	TA792 5" x 4-1/2" (qty per part 2)	US26D	MK
2	Exit Device (SVR,LBR,passage)	12 NB8715 ETP	US32D	SA
2	Surface Closer (interior)	DC6200 A10 or DC6210 A3; M73	689	RU
4	Kick Plate	K1050 10" 4BE CSK	US32D	RO
2	Electromagnetic Holder	998M (or to suit details)	689	RF
1	Head & Jamb Seal (adhesive)	S88BL		PE
1	Astragal	357SS		PE
1	Astragal (adhesive, edge mount)	S772C		PE

Notes: Interface with building fire alarm system to release door(s) from hold open.

Set: 14.0

Description: Corridor; Stair Pair

2	Anchor Hinge Set, Hvy Wt	TA792 5" x 4-1/2" (qty per part 2)	US26D	MK
2	Exit Device (SVR,LBR,passage)	12 NB8715 ETP	US32D	SA
2	Surface Closer (interior)	DC6200 A10 or DC6210 A3; M73	689	RU
2	Kick Plate	K1050 10" 4BE CSK	US32D	RO
2	Mop Plate	K1050 6" 4BE CSK	US32D	RO
2	Door Stop	404 Wall; 441CU Floor (or per spec)	US26D	
	RO			
1	Head & Jamb Seal (adhesive)	S88BL		PE
1	Astragal (adhesive, edge mount)	S772C		PE

Set: 15.0

Description: Corridor Double Egress Pair - Hold Open

2	Anchor Hinge Set, Hvy Wt	TA792 5" x 4-1/2" (qty per part 2)	US26D	MK
---	--------------------------	------------------------------------	-------	----

2	Exit Device (SVR,LBR,passage)	12 NB8715 ETP	US32D	SA
2	Surface Closer (interior)	DC6200 A10 or DC6210 A3; M73	689	RU
2	Kick Plate	K1050 10" 4BE CSK	US32D	RO
2	Mop Plate	K1050 6" 4BE CSK	US32D	RO
2	Electromagnetic Holder	998M (or to suit details)	689	RF
1	Head & Jamb Seal (adhesive)	S88BL		PE
1	Astragal (adhesive, edge mount)	S772C		PE
1	Astragal	357SP		PE

Notes: Interface with building fire alarm system to release door(s) from hold open.

Set: 16.0

Description: Stair - Hold Open

1	Anchor Hinge Set, Hvy Wt	TA792 5" x 4-1/2" (qty per part 2)	US26D	MK
1	Exit Device (rim, passage)	12 8815 ETP	US32D	SA
1	Surface Closer (interior)	DC6200 A10 or DC6210 A3; M73	689	RU
1	Kick Plate	K1050 10" 4BE CSK	US32D	RO
1	Mop Plate	K1050 6" 4BE CSK	US32D	RO
1	Electromagnetic Holder	998M (or to suit details)	689	RF
1	Head & Jamb Seal (adhesive)	S88BL		PE

Notes: Interface with building fire alarm system to release door(s) from hold open.
 Review locking requirements for stair to basement.

Set: 17.0

Description: Stair (Level of exit discharge) - Card Access

1	Anchor Hinge Set, Hvy Wt	TA792 5" x 4-1/2" (qty per part 2)	US26D	MK
1	Exit Device (rim, fail-secure)	12 43 64 8876 ETP	US32D	SA
1	Removable Core (interior)	CR8000 Keyed to existing system	626	RU
1	Cylinder (Sargent interior devices)			LFIC to suit device
	626		RU	
1	Surface Closer (interior)	DC6200 A10 or DC6210 A3; M73	689	RU
1	Kick Plate	K1050 10" 4BE CSK	US32D	RO
1	Mop Plate	K1050 6" 4BE CSK	US32D	RO
1	Head & Jamb Seal (adhesive)	S88BL		PE
1	Door Wiring Harness	QC Series (hinge to device)		MK
1	Frame Wiring Harness	QC Series (jamb to J-box)		MK
1	Power Supply	AQD4 Series (coord w/ security)		SU
1	Electric Power Transfer	EL-CEPT		SU
1	DPS & REX Devices	By Security Vendor		
1	Card Reader	By Security Vendor		

Notes:

Operation: Door is normally closed and locked. Valid card at reader unlocks outside lever for momentary access. Monitoring by door position switch. During a loss of power the door will default to secure. Free egress at all times. Lock status will not change when the fire

detection/suppression systems are activated. Approaching door on egress side will activate request to exit switch for appropriate monitor by EAC systems. Outside key override.

Set: 18.0

Description: Elev Vestibule - Hold Open

1	Anchor Hinge Set, Hvy Wt	TA792 5" x 4-1/2" (qty per part 2)	US26D	MK
1	Passage Latch	ML2010 PSA	626	RU
1	Surface Closer (interior)	DC6200 A10 or DC6210 A3; M73	689	RU
1	Kick Plate	K1050 10" 4BE CSK	US32D	RO
1	Mop Plate	K1050 6" 4BE CSK	US32D	RO
1	Electromagnetic Holder	998M (or to suit details)	689	RF
1	Head & Jamb Seal (adhesive)	S88BL		PE

Notes: Interface with building fire alarm system to release door(s) from hold open.

Set: 19.0

Description: Assembly

1	Anchor Hinge Set, Hvy Wt	TA792 5" x 4-1/2" (qty per part 2)	US26D	MK
1	Exit Device (rim, intruder)	LD (12 if rated) 43 49 8816 ETP	US32D	SA
2	Removable Core (interior)	CR8000 Keyed to existing system	626	RU
2	Cylinder (Sargent interior devices)			LFIC to suit device
	626	RU		
1	Surface Closer (interior)	DC6200 A10 or DC6210 A3; M73	689	RU
1	Kick Plate	K1050 10" 4BE CSK	US32D	RO
1	Mop Plate	K1050 6" 4BE CSK	US32D	RO
1	Door Stop	404 Wall; 441CU Floor (or per spec)		US26D
	RO			
1	Head & Jamb Seal (adhesive)	S88BL		PE

Set: 20.0

Description: Assembly Pair

2	Anchor Hinge Set, Hvy Wt	TA792 5" x 4-1/2" (qty per part 2)	US26D	MK
1	Key Removable Mullion	L980S	PC	SA
2	Exit Device (rim, intruder)	LD (12 if rated) 43 49 8816 ETP	US32D	SA
3	Removable Core (interior)	CR8000 Keyed to existing system	626	RU
2	Cylinder (Sargent interior devices)			LFIC to suit device
	626	RU		
1	Mullion Cylinder	64 980C1	US26D	SA
2	Door Closer (HD stop)	UNI7500 M	689	NO
2	Kick Plate	K1050 10" 4BE CSK	US32D	RO
2	Mop Plate	K1050 6" 4BE CSK	US32D	RO
2	Door Stop	404 Wall; 441CU Floor (or per spec)		US26D
	RO			
1	Threshold (coord w/ details)	271A FHSL14SS		PE
1	Mullion Gasket	5110BL		PE
1	Head & Jamb Seal (adhesive)	S88BL		PE

1 Astragal (adhesive, edge mount) [S772C](#) PE

Notes: Coordinate seals with frame material/Mfr. Door stops should be reviewed, overhead vs floor mount.

Set: 20.1

Description: Assembly Pair - Hold Open (floor)

2	Anchor Hinge Set, Hvy Wt	TA792 5" x 4-1/2" (qty per part 2)	US26D	MK
2	Exit Device (SVR,LBR,classrm,CD)		16 43 64	NB8713 ETP
	US32D	SA		
4	Removable Core (interior)	CR8000 Keyed to existing system	626	RU
4	Cylinder (Sargent interior devices)		LFIC to suit device	
	626	RU		
2	Surface Closer (interior)	DC6200 A10 or DC6210 A3; M73	689	RU
2	Kick Plate	K1050 10" 4BE CSK	US32D	RO
2	Mop Plate	K1050 6" 4BE CSK	US32D	RO
2	Electromagnetic Holder (floor)	980M	689	RF
1	Threshold (coord w/ details)	271A FHSL14SS		PE
1	Head & Jamb Seal (adhesive)	S88BL		PE
1	Astragal (adhesive, edge mount)	S772C		PE

Notes: Coordinate seals with frame material/Mfr.
 Interface with building fire alarm system to release door(s) from hold open.

Set: 21.0

Description: Single w/ Card Access

1	Anchor Hinge Set, Hvy Wt	TA792 5" x 4-1/2" (qty per part 2)	US26D	MK
1	Mortise Lock (fail-secure)	ML20906-SEC PSA LFIC	626	RU
1	Removable Core (interior)	CR8000 Keyed to existing system	626	RU
1	Surface Closer (interior)	DC6200 A10 or DC6210 A3; M73	689	RU
1	Kick Plate	K1050 10" 4BE CSK	US32D	RO
1	Mop Plate	K1050 6" 4BE CSK	US32D	RO
1	Door Stop	404 Wall; 441CU Floor (or per spec)		US26D
	RO			
1	Head & Jamb Seal (adhesive)	S88BL		PE
1	Door Wiring Harness	QC Series (hinge to device)		MK
1	Frame Wiring Harness	QC Series (jamb to J-box)		MK
1	Power Supply	AQD4 Series (coord w/ security)		SU
1	Electric Power Transfer	EL-CEPT		SU
1	Card Reader	By Security Vendor		

Notes:
 Operation: Door is normally closed and locked. Valid card at reader unlocks outside lever for momentary access. Monitoring by door position switch. During a loss of power the door will default to secure. Free egress at all times. Lock status will not change when the fire detection/suppression systems are activated. Approaching door from egress side will activate request to exit switch for appropriate monitor by EAC systems. Outside key override.

Set: 22.0

Description: Classroom - Hold Open

1	Anchor Hinge Set, Hvy Wt	TA792 5" x 4-1/2" (qty per part 2)	US26D	MK
1	Classroom Lock (inside indicator)	ML2052 PSA V01 LFIC	626	RU
2	Removable Core (interior)	CR8000 Keyed to existing system	626	RU
1	Surface Closer (interior)	DC6200 A10 or DC6210 A3; M73	689	RU
1	Kick Plate	K1050 10" 4BE CSK	US32D	RO
1	Mop Plate	K1050 6" 4BE CSK	US32D	RO
1	Electromagnetic Holder	998M (or to suit details)	689	RF
1	Head & Jamb Seal (adhesive)	S88BL		PE

Notes: Interface with building fire alarm system and remote release switch to release doors from hold open (typ).

Provide Finger guards for all doors in K and Pre-K areas, MK1A/MK1B x door height, color to be selected (fingersafe.com).

Review panic hardware requirement with code official for doors 405 and 406.

Set: 23.0

Description: Classroom - Hold Open; Panic

1	Anchor Hinge Set, Hvy Wt	TA792 5" x 4-1/2" (qty per part 2)	US26D	MK
1	Exit Device (rim, intruder)	LD (12 if rated) 43 49 8816 ETP	US32D	SA
2	Removable Core (interior)	CR8000 Keyed to existing system	626	RU
2	Cylinder (Sargent interior devices)			LFIC to suit device
	626	RU		
1	Surface Closer (interior)	DC6200 A10 or DC6210 A3; M73	689	RU
1	Kick Plate	K1050 10" 4BE CSK	US32D	RO
1	Mop Plate	K1050 6" 4BE CSK	US32D	RO
1	Electromagnetic Holder	998M (or to suit details)	689	RF
1	Head & Jamb Seal (adhesive)	S88BL		PE

Notes: Interface with building fire alarm system and remote release switch to release doors from hold open (typ).

Set: 24.0

Description: Music Vestibule - Hold Open; Panic

1	Anchor Hinge Set, Hvy Wt	TA792 5" x 4-1/2" (qty per part 2)	US26D	MK
1	Exit Device (rim, intruder)	LD (12 if rated) 43 49 8816 ETP	US32D	SA
2	Removable Core (interior)	CR8000 Keyed to existing system	626	RU
2	Cylinder (Sargent interior devices)			LFIC to suit device
	626	RU		
1	Surface Closer (interior)	DC6200 A10 or DC6210 A3; M73	689	RU
1	Kick Plate	K1050 10" 4BE CSK	US32D	RO
1	Mop Plate	K1050 6" 4BE CSK	US32D	RO
1	Electromagnetic Holder	998M (or to suit details)	689	RF

1	Head & Jamb Seal (adhesive)	S88BL		PE
1	Door Bottom (concealed, auto)	434ARL		PE

Notes: Interface with building fire alarm system and remote release switch to release doors from hold open (typ).

Set: 25.0

Description: Music - STC43; Hold Open; Panic

1	Anchor Hinge Set, Hvy Wt	TA792 5" x 4-1/2" (qty per part 2)	US26D	MK
1	Exit Device (rim, intruder)	LD (12 if rated) 43 49 8816 ETP	US32D	SA
2	Removable Core (interior)	CR8000 Keyed to existing system	626	RU
2	Cylinder (Sargent interior devices)			LFIC to suit device
	626	RU		
1	Surface Closer (interior)	DC6200 A10 or DC6210 A3; M73	689	RU
1	Kick Plate	K1050 10" 4BE CSK	US32D	RO
1	Mop Plate	K1050 6" 4BE CSK	US32D	RO
1	Electromagnetic Holder	998M (or to suit details)	689	RF
1	Head & Jamb Seal (adhesive)	S88BL		PE
1	Door Bottom (concealed, auto)	434ARL		PE

Notes: Interface with building fire alarm system and remote release switch to release doors from hold open (typ).

Coordinate hardware with STC assembly manufacturer.

Set: 26.0

Description: Classroom / Resource - Connecting

1	Anchor Hinge Set, Hvy Wt	TA792 5" x 4-1/2" (qty per part 2)	US26D	MK
1	Security Lock (2 indicators)	ML2022 PSA V11 LFIC	626	RU
2	Removable Core (interior)	CR8000 Keyed to existing system	626	RU
1	Surface Closer (interior)	DC6200 A10 or DC6210 A3; M73	689	RU
1	Kick Plate	K1050 10" 4BE CSK	US32D	RO
1	Mop Plate	K1050 6" 4BE CSK	US32D	RO
1	Door Stop	404 Wall; 441CU Floor (or per spec)		US26D
	RO			
1	Head & Jamb Seal (adhesive)	S88BL		PE

Set: 27.0

Description: Classroom Connecting - Surface Slider

1	Mortise Deadlock (hook bolt)	MS1850SN 45	628	AD
2	Removable Core (interior)	CR8000 Keyed to existing system	626	RU
2	Cylinder (Sargent interior devices)			LFIC to suit device
	626	RU		
1	Door Pull	RM3301-24" Mtg-Type 1XHD	US32D	RO
2	Lock Status Indicator	4089 less signage	130	AD

Notes: Track; sliding hardware; perimeter seals and door bottom supplied with door assembly.

Set: 28.0

Description: Classroom Storage; Prep; Kiln; Copy

1	Anchor Hinge Set, Hvy Wt	TA792 5" x 4-1/2" (qty per part 2)	US26D	MK
1	Classroom Lock	ML2055 PSA LFIC	626	RU
1	Removable Core (interior)	CR8000 Keyed to existing system	626	RU
1	Surface Closer (interior)	DC6200 A10 or DC6210 A3; M73	689	RU
1	Kick Plate	K1050 10" 4BE CSK	US32D	RO
1	Mop Plate	K1050 6" 4BE CSK	US32D	RO
1	Door Stop	404 Wall; 441CU Floor (or per spec)		US26D
	RO			
1	Head & Jamb Seal (adhesive)	S88BL		PE

Set: 29.0

Description: Servery - Hold Open

1	Anchor Hinge Set, Hvy Wt	TA792 5" x 4-1/2" (qty per part 2)	US26D	MK
1	Classroom Lock (inside indicator)	ML2052 PSA V01 LFIC	626	RU
2	Removable Core (interior)	CR8000 Keyed to existing system	626	RU
1	Surface Closer (interior)	DC6200 A10 or DC6210 A3; M73	689	RU
1	Kick Plate	K1050 10" 4BE CSK	US32D	RO
1	Mop Plate	K1050 6" 4BE CSK	US32D	RO
1	Electromagnetic Holder	998M (or to suit details)	689	RF
3	Silencer	608		RO

Notes: Interface with building fire alarm system and remote release switch to release doors from hold open (typ).

Set: 30.0

Description: Kitchen

1	Anchor Hinge Set, Hvy Wt	TA792 5" x 4-1/2" (qty per part 2)	US26D	MK
1	Classroom Lock (inside indicator)	ML2052 PSA V01 LFIC	626	RU
2	Removable Core (interior)	CR8000 Keyed to existing system	626	RU
1	Surface Closer (interior)	DC6200 A10 or DC6210 A3; M73	689	RU
1	Kick Plate	K1050 10" 4BE CSK	US32D	RO
1	Mop Plate	K1050 6" 4BE CSK	US32D	RO
1	Head & Jamb Seal (adhesive)	S88BL		PE
1	Sweep	18061CNB		PE

Set: 31.0

Description: Storage; Bldg Services Pair

2	Anchor Hinge Set, Hvy Wt	TA792 5" x 4-1/2" (qty per part 2)	US26D	MK
1	Dust Proof Strike	570	US26D	RO
2	Flush Bolt (manual)	555	US26D	RO
1	Storeroom Lock	ML2057 PSA LFIC	626	RU
1	Removable Core (interior)	CR8000 Keyed to existing system	626	RU

1	Surface Closer (interior)	DC6200 A10 or DC6210 A3; M73	689	RU
2	Kick Plate	K1050 10" 4BE CSK	US32D	RO
2	Mop Plate	K1050 6" 4BE CSK	US32D	RO
2	Door Stop RO	404 Wall; 441CU Floor (or per spec)		US26D
1	Threshold (coord w/ details)	271A FHSL14SS		PE
1	Head & Jamb Seal (adhesive)	S88BL		PE
1	Astragal (adhesive, edge mount)	S772C		PE
1	Astragal	357SP		PE

Set: 32.0

Description: Storage; Bldg Services

1	Anchor Hinge Set, Hvy Wt	TA792 5" x 4-1/2" (qty per part 2)	US26D	MK
1	Storeroom Lock	ML2057 PSA LFIC	626	RU
1	Removable Core (interior)	CR8000 Keyed to existing system	626	RU
1	Surface Closer (interior)	DC6200 A10 or DC6210 A3; M73	689	RU
1	Kick Plate	K1050 10" 4BE CSK	US32D	RO
1	Mop Plate	K1050 6" 4BE CSK	US32D	RO
1	Door Stop RO	404 Wall; 441CU Floor (or per spec)		US26D
1	Threshold (coord w/ details)	271A FHSL14SS		PE
1	Head & Jamb Seal (adhesive)	S88BL		PE

Set: 33.0

Description: Electric; Generator Pair

2	Anchor Hinge Set, Hvy Wt	TA792 5" x 4-1/2" (qty per part 2)	US26D	MK
1	Key Removable Mullion	12-L980	PC	SA
1	Exit Device (rim, storeroom)	12 43 64 8804 ETP	US32D	SA
1	Exit Device (rim, exit only)	12 43 8810 EO	US32D	SA
2	Removable Core (interior)	CR8000 Keyed to existing system	626	RU
2	Cylinder (Sargent interior devices) 626			LFIC to suit device RU
1	Mullion Cylinder	64 980C1	US26D	SA
2	Surface Closer (interior)	DC6200 A10 or DC6210 A3; M73	689	RU
2	Kick Plate	K1050 10" 4BE CSK	US32D	RO
2	Mop Plate	K1050 6" 4BE CSK	US32D	RO
2	Door Stop RO	404 Wall; 441CU Floor (or per spec)		US26D
1	Mullion Gasket	5110BL		PE
1	Head & Jamb Seal (adhesive)	S88BL		PE
1	Astragal (adhesive, edge mount)	S772C		PE

Set: 34.0

Description: Electric

1	Anchor Hinge Set, Hvy Wt	TA792 5" x 4-1/2" (qty per part 2)	US26D	MK
1	Exit Device (rim, storeroom)	12 43 64 8804 ETP	US32D	SA

1	Removable Core (interior)	CR8000 Keyed to existing system	626	RU
1	Cylinder (Sargent interior devices)		LFIC to suit device	
	626	RU		
1	Surface Closer (interior)	DC6200 A10 or DC6210 A3; M73	689	RU
1	Kick Plate	K1050 10" 4BE CSK	US32D	RO
1	Mop Plate	K1050 6" 4BE CSK	US32D	RO
1	Door Stop	404 Wall; 441CU Floor (or per spec)		US26D
	RO			
1	Head & Jamb Seal (adhesive)	S88BL		PE

Set: 35.0

Description: Stage Lift Pair

2	Anchor Hinge Set, Hvy Wt	TA792 5" x 4-1/2" (qty per part 2)	US26D	MK
1	Dust Proof Strike	570	US26D	RO
1	Flush Bolt Set (self-latching)	2845; 2945	US26D	RO
1	Classroom Lock	ML2055 PSA LFIC	626	RU
1	Removable Core (interior)	CR8000 Keyed to existing system	626	RU
2	Surface Closer (interior)	DC6200 A10 or DC6210 A3; M73	689	RU
2	Kick Plate	K1050 10" 4BE CSK	US32D	RO
2	Door Stop	404 Wall; 441CU Floor (or per spec)		US26D
	RO			
2	Silencer	608		RO

Set: 36.0

Description: Office; Conf; Nurse; Counsel

1	Anchor Hinge Set, Hvy Wt	TA792 5" x 4-1/2" (qty per part 2)	US26D	MK
1	Classroom Lock	ML2055 PSA LFIC	626	RU
1	Removable Core (interior)	CR8000 Keyed to existing system	626	RU
1	Kick Plate	K1050 10" 4BE CSK	US32D	RO
1	Mop Plate	K1050 6" 4BE CSK	US32D	RO
1	Door Stop	404 Wall; 441CU Floor (or per spec)		US26D
	RO			
3	Silencer	608		RO

Set: 37.0

Description: Office w/ Closer

1	Anchor Hinge Set, Hvy Wt	TA792 5" x 4-1/2" (qty per part 2)	US26D	MK
1	Classroom Lock (inside indicator)	ML2052 PSA V01 LFIC	626	RU
2	Removable Core (interior)	CR8000 Keyed to existing system	626	RU
1	Surface Closer (interior)	DC6200 A10 or DC6210 A3; M73	689	RU
1	Kick Plate	K1050 10" 4BE CSK	US32D	RO
1	Mop Plate	K1050 6" 4BE CSK	US32D	RO
1	Door Stop	404 Wall; 441CU Floor (or per spec)		US26D
	RO			
1	Head & Jamb Seal (adhesive)	S88BL		PE

Set: 38.0

Description: Restroom (Faculty)

1	Anchor Hinge Set, Hvy Wt	TA792 5" x 4-1/2" (qty per part 2)	US26D	MK
1	Staff Toilet Lock (2 indicators)	ML2029 PSA V21 LFIC	626	RU
1	Removable Core (interior)	CR8000 Keyed to existing system	626	RU
1	Surface Closer (interior)	DC6200 A10 or DC6210 A3; M73	689	RU
1	Kick Plate	K1050 10" 4BE CSK	US32D	RO
1	Mop Plate	K1050 6" 4BE CSK	US32D	RO
1	Door Stop	404 Wall; 441CU Floor (or per spec)		US26D
	RO			
3	Silencer	608		RO
1	Coat Hook	RM823	US32D	RO

Set: 39.0

Description: Restroom (single user)

1	Anchor Hinge Set, Hvy Wt	TA792 5" x 4-1/2" (qty per part 2)	US26D	MK
1	Privacy Lock w/ Indicator	ML2060 PSA V20	626	RU
1	Surface Closer (interior)	DC6200 A10 or DC6210 A3; M73	689	RU
1	Kick Plate	K1050 10" 4BE CSK	US32D	RO
1	Mop Plate	K1050 6" 4BE CSK	US32D	RO
1	Door Stop	404 Wall; 441CU Floor (or per spec)		US26D
	RO			
3	Silencer	608		RO

Set: 40.0

Description: Restroom (multi-user); Lockers

1	Anchor Hinge Set, Hvy Wt	TA792 5" x 4-1/2" (qty per part 2)	US26D	MK
1	Deadbolt (dbl cyl classrm)	DL4122 CT6	626	RU
2	Removable Core (interior)	CR8000 Keyed to existing system	626	RU
1	Push Pull	111x73C/73CL (deadbolt prep)	US32D	RO
1	Surface Closer (interior)	DC6200 A10 or DC6210 A3; M73	689	RU
1	Kick Plate	K1050 10" 4BE CSK	US32D	RO
1	Mop Plate	K1050 6" 4BE CSK	US32D	RO
1	Door Stop	404 Wall; 441CU Floor (or per spec)		US26D
	RO			
3	Silencer	608		RO

Set: 41.0

Description: Restroom (K and Pre-K)

1	Anchor Hinge Set, Hvy Wt	TA792 5" x 4-1/2" (qty per part 2)	US26D	MK
1	Passage Latch	ML2010 PSA	626	RU
1	Surface Closer (interior)	DC6200 A10 or DC6210 A3; M73	689	RU
1	Kick Plate	K1050 10" 4BE CSK	US32D	RO
1	Mop Plate	K1050 6" 4BE CSK	US32D	RO

1	Door Stop RO	404 Wall; 441CU Floor (or per spec)	US26D
3	Silencer	608	RO
1	Finger Guard Set	MK1A & MK1B (fingersafe.com)	

Set: 42.0

Description: Exam; Dentist

1	Anchor Hinge Set, Hvy Wt	TA792 5" x 4-1/2" (qty per part 2)	US26D	MK
1	Passage Latch	ML2010 PSA	626	RU
1	Kick Plate	K1050 10" 4BE CSK	US32D	RO
1	Mop Plate	K1050 6" 4BE CSK	US32D	RO
1	Door Stop RO	404 Wall; 441CU Floor (or per spec)	US26D	
3	Silencer	608	RO	

Set: 43.0

Description: Overhead or Specialty Door Assembly

1	Hardware	Supplied with door assembly	
---	----------	-----------------------------	--

Set: 44.0

Description: Misc Items; Owner Stock

2	Anchor Hinge Set, Hvy Wt	TA792 5" x 4-1/2" (qty per part 2)	US26D	MK
2	Classroom Lock (inside indicator)	ML2052 PSA V01 LFIC	626	RU
6	Removable X4 Core (exterior)	322401-N (to fit Sargent LFIC)	26	MC
6	Removable Core (interior)	CR8000 Keyed to existing system	626	RU
2	Door Closer (HD stop)	UNI7500 M	689	NO
2	Surface Closer (interior)	DC6200 A10 or DC6210 A3; M73	689	RU
2	Electromagnetic Holder	998M (or to suit details)	689	RF
10	Wiring Diagram (as required)	Elevation & Point-to-Point		
100	Key Blanks	Bldg Std Keyway		
1	Key Cabinet (per spec)	Including Set-up		
1	Finger Guard Set	MK1A & MK1B (fingersafe.com)		

Notes: Provide Finger guards for all doors in K and Pre-K areas, MK1A/MK1B x door height, color to be selected (fingersafe.com).

Set: 45.0

Description: Gate w/ Panic

1	Exit Device (rim,NL,CD)	16 43 64 8504	US32D	SA
1	Pull (offset)	862	US32D	SA
1	Removable X4 Core (exterior)	322401-N (to fit Sargent LFIC)	26	MC

Notes: Coord hardware with gate mfr. Gate needs to be designed/constructed to accommodate panic hardware.

Remainder of hardware supplied with gate assembly.

Set: 46.0

Description: Gate w/ Panic - Card Access

1	Exit Device (rim,NL,CD)	16 43 64 8504	US32D	SA
1	Pull (offset)	862	US32D	SA
1	Removable X4 Core (exterior)	322401-N (to fit Sargent LFIC)	26	MC
1	Electric Strike	9400; 9600-LBM	630	HS
1	SMART Pac Bridge Rectifier	2005M3		HS
1	Power Supply	AQD4 Series (coord w/ security)		SU
1	Card Reader	By Security Vendor		

Notes: Coord hardware with gate mfr. Gate needs to be designed/constructed to accommodate panic and electrified hardware.

Remainder of hardware supplied with gate assembly.

END OF SECTION 087100

SECTION 088000 - GLAZING

PART 1 - GENERAL

1.1 SUMMARY

- A. This Section includes glazing for the following products and applications, including those specified in other Sections where glazing requirements are specified by reference to this Section:
1. Windows.
 2. Doors.
 3. Interior borrowed lites, sidelights and transoms.
 4. Glazed entrances.
 5. Curtainwall framing.
 6. Storefront framing.
 7. Metal-framed skylights.
 8. Transaction windows.
 9. Folding glass storefronts.

1.2 DEFINITIONS

- A. Manufacturer: A firm that produces primary glass or fabricated glass as defined in referenced glazing publications.
- B. Interspace: Space between lites of an insulating-glass unit that contains dehydrated air or a specified gas.
- C. Deterioration of Coated Glass: Defects developed from normal use that are attributed to the manufacturing process and not to causes other than glass breakage and practices for maintaining and cleaning coated glass contrary to manufacturer's written instructions. Defects include peeling, cracking, and other indications of deterioration in metallic coating.
- D. Deterioration of Laminated Glass: Defects developed from normal use that are attributed to the manufacturing process and not to causes other than glass breakage and practices for maintaining and cleaning laminated glass contrary to manufacturer's written instructions. Defects include edge separation, delamination materially obstructing vision through glass, and blemishes exceeding those allowed by referenced laminated-glass standard.
- E. Deterioration of Insulating Glass: Failure of the hermetic seal under normal use that is attributed to the manufacturing process and not to causes other than glass breakage and practices for maintaining and cleaning insulating glass contrary to manufacturer's written instructions. Evidence of failure is the obstruction of vision by dust, moisture, or film on interior surfaces of glass.

1.3 PERFORMANCE REQUIREMENTS

- A. General: Provide glazing systems capable of withstanding normal thermal movement and wind and impact loads (where applicable) without failure, including loss or glass breakage attributable to the following: defective manufacture, fabrication, and installation; failure of sealants or gaskets to remain watertight and airtight; deterioration of glazing materials; or other defects in construction.
- B. Glass Design: Where glass thicknesses are indicated these are minimums and are for detailing only. Confirm glass thicknesses by analyzing Project loads and in-service conditions. Where glass thickness is not indicated design glass thickness and types of glass required by analyzing Project loads and in-service conditions. Provide glass lites for various size openings in nominal thicknesses indicated, but not less than thicknesses and in strengths (annealed or heat treated) required to meet or exceed the following criteria:
 - 1. Glass Thicknesses: Select minimum glass thicknesses to comply with ASTM E 1300, according to the following requirements:
 - a. Wind Loads: Provide glazing capable of resisting wind positive and negative pressures calculated according to the New York Building Code Section 1609.6 and the following criteria:
 - 1) Basic Wind Speed (3 second gust) = as indicated on Structural Drawings
 - 2) Wind Load Importance Factor I_w = as indicated on Structural Drawings
 - 3) Wind Speed Category = as indicated on Structural Drawings
 - 4) Other applicable criteria indicated on Structural Drawings.
 - b. Specified Design Snow Loads: As indicated on Structural Drawings
 - c. Probability of Breakage for Vertical Glazing: 8 lites per 1000 for lites set vertically or not more than 15 degrees off vertical and under wind action.
 - 1) Load Duration: 60 seconds or less.
 - d. Probability of Breakage for Sloped Glazing: 1 lite per 1000 for lites set more than 15 degrees off vertical and under wind and snow action.
 - 1) Load Duration: 30 days
 - e. Probability of Breakage for Vertical Glazing: 8 lites per 1000 for lites set vertically or not more than 15 degrees off vertical and under wind action.
 - 1) Load Duration: 60 seconds or less.
 - f. Maximum Lateral Deflection: For the following types of glass supported on all four edges, provide thickness required that limits center deflection at design wind pressure to 1/50 times the short side length or 1 inch (25 mm), whichever is less.
 - 1) For insulating glass.
 - 2) For laminated glass
 - 3) For monolithic-glass lites heat treated to resist wind loads.
 - g. Minimum Glass Thickness for Exterior Lites: Not less than 1/4" (6 mm).
 - h. Thickness of Tinted and Heat-Absorbing Glass: Provide the same thickness for each tint color indicated throughout Project.

- C. Thermal Movements: Provide glazing that allows for thermal movements resulting from the following maximum change (range) in ambient and surface temperatures acting on glass framing members and glazing components. Base engineering calculation on surface temperatures of materials due to both solar heat gain and nighttime-sky heat loss.
1. Temperature Change (Range): 120 deg F (67 deg C), ambient; 180 deg F (100 deg C), material surfaces.
- D. Thermal and Optical Performance Properties: Provide glass with performance properties specified based on manufacturer's published test data, as determined according to procedures indicated below:
1. For monolithic-glass lites, properties are based on units with lites 6 mm thick, unless otherwise indicated.
 2. For laminated-glass lites, properties are based on products of construction indicated.
 3. For insulating-glass units, properties are based on units with lites 6 mm thick and a nominal 1/2-inch- (13-mm-) wide interspace, unless otherwise indicated.
 4. Center-of-Glass U-Values: NFRC 100 methodology using LBL-35298 WINDOW 4.1 computer program, expressed as Btu/ sq. ft. x h x deg F (W/sq. m x K).
 5. Center-of-Glass Solar Heat Gain Coefficient: NFRC 200 methodology using LBL-35298 WINDOW 4.1 computer program.
 6. Solar Optical Properties: NFRC 300.

1.4 SUBMITTALS

- A. Product Data: For each glass product and glazing material indicated.
- B. Samples: For the following products, in the form of 12-inch- (300-mm-) square Samples for glass and of 12-inch- (300-mm-) long Samples for sealants. Install sealant Samples between two strips of material representative in color of the adjoining framing system.
1. Insulating glass for each designation indicated.
 2. Each type of laminated glass specified.
 3. Each type of fire-rated glass specified.
 4. For each color (except black) of exposed glazing sealant indicated.
 5. Spandrel glass
 6. Silk screened ceramic fritted glass, for each pattern indicated
- C. Glazing Schedule: Use same designations indicated on Drawings for glazed openings in preparing a schedule listing glass types and thicknesses for each size opening and location.
- D. Product Certificates: Signed by manufacturers of glass and glazing products certifying that products furnished comply with requirements.

1. For solar-control low-e-coated glass, provide documentation demonstrating that manufacturer of coated glass is certified by coating manufacturer
- E. Qualification Data: For firms and persons specified in "Quality Assurance" Article to demonstrate their capabilities and experience. Include lists of completed projects with project names and addresses, names and addresses of architects and owners, and other information specified.
- F. Preconstruction Adhesion and Compatibility Test Report: From glazing sealant manufacturer indicating glazing sealants were tested for adhesion to glass and glazing channel substrates and for compatibility with glass and other glazing materials.
- G. Product Test Reports: From a qualified testing agency indicating the following products comply with requirements, based on comprehensive testing of current products:
 1. Insulating glass.
 2. Coated float glass.
 3. Glazing sealants.
 4. Fire resistive glazing
- H. Warranties: Special warranties specified in this Section.

1.5 QUALITY ASSURANCE

- A. Installer Qualifications: An experienced installer who has completed glazing similar in material, design, and extent to that indicated for Project and whose work has resulted in construction with a record of successful in-service performance.
- B. Source Limitations: Obtain each type of glass from one primary-glass manufacturer.
- C. Source Limitations for Glass Sputter-Coated with Solar-Control Low-E Coatings: Where solar-control low-e coatings of a primary glass manufacturer that has established a certified fabricator program is specified, obtain sputter-coated solar-control low-e-coated glass in fabricated units from a manufacturer that is certified by coated-glass manufacturer
- D. Glass Product Testing: Obtain glass test results for product test reports in "Submittals" Article from a qualified testing agency based on testing glass products.
 1. Glass Testing Agency Qualifications: An independent testing agency with the experience and capability to conduct the testing indicated, as documented according to ASTM E 548.
- E. Elastomeric Glazing Sealant Product Testing: Obtain sealant test results for product test reports in "Submittals" Article from a qualified testing agency based on testing current sealant formulations within a 36-month period.

1. Sealant Testing Agency Qualifications: An independent testing agency qualified according to ASTM C 1021 to conduct the testing indicated, as documented according to ASTM E 548.
 2. Test elastomeric glazing sealants for compliance with requirements specified by reference to ASTM C 920, and where applicable, to other standard test methods.
- F. Preconstruction Adhesion and Compatibility Testing: Submit to elastomeric glazing sealant manufacturers, for testing indicated below, samples of each glass type, tape sealant, gasket, glazing accessory, and glass-framing member that will contact or affect elastomeric glazing sealants.
1. Use manufacturer's standard test methods to determine whether priming and other specific preparation techniques are required to obtain rapid, optimum adhesion of glazing sealants to glass, tape sealants, gaskets, and glazing channel substrates.
 - a. Perform tests under normal environmental conditions replicating those that will exist during installation.
 2. Submit not fewer than nine pieces of each type and finish of glass-framing members and each type, class, kind, condition, and form of glass (monolithic, laminated, and insulating units) as well as one sample of each glazing accessory (gaskets, tape sealants, setting blocks, and spacers).
 3. Schedule sufficient time for testing and analyzing results to prevent delaying the Work.
 4. For materials failing tests, obtain sealant manufacturer's written instructions for corrective measures, including the use of specially formulated primers.
 5. Testing will not be required if elastomeric glazing sealant manufacturers submit data based on previous testing of current sealant products for adhesion to, and compatibility with, glazing materials matching those submitted.
- G. Glazing for Fire-Rated Door Assemblies: Glazing for assemblies that comply with NFPA 80 and that are listed and labeled by UL, for fire ratings indicated, based on testing according to NFPA 252.
- H. Glazing for Fire-Rated Window Assemblies: Glazing for assemblies that comply with NFPA 80 and that are listed and labeled by UL, for fire ratings indicated, based on testing according to NFPA 257.
- I. Glazing for Fire-Rated Wall Assemblies: Glazing for assemblies that comply with NFPA 80 and that are listed and labeled by UL, for fire ratings indicated, based on testing according to NFPA 257, ASTM E119.
- J. Safety Glass: Category II materials complying with testing requirements in 16 CFR 1201 and ANSI Z97.1.
1. Subject to compliance with requirements, permanently mark safety glass with certification label of Safety Glazing Certification Council or another certification agency acceptable to authorities having jurisdiction.
 2. Safety glass includes fully tempered glass, laminated glass and fire-resistant glass.

- K. Fire-Rated Glass: Permanently mark fire-rated glass with certification label of certification agency acceptable to authorities having jurisdiction indicating manufacturer name, test standard and fire-rating.
- L. Glazing Publications: Comply with published recommendations of glass product manufacturers and organizations below, unless more stringent requirements are indicated. Refer to these publications for glazing terms not otherwise defined in this Section or in referenced standards.
 - 1. SIGMA Publications: SIGMA TM-3000, "Vertical Glazing Guidelines."
 - 2. GANA Publications: GANA'S "Glazing Manual" and "Laminated Glass Design Guide."
 - 3. IGMA Publication for Insulating Glass: SIGMA TM-3000, "Glazing Guidelines for Sealed Insulating Glass Units."
- M. Insulating-Glass Certification Program: Permanently marked either on spacers or on at least one component lite of units with appropriate certification label of the following inspecting and testing agency:
 - 1. Insulating Glass Certification Council.
 - 2. Associated Laboratories, Inc.
 - 3. National Accreditation and Management Institute.
- N. Preinstallation Conference: Conduct conference at Project site to comply with requirements in Division 01.

1.6 DELIVERY, STORAGE, AND HANDLING

- A. Protect glazing materials according to manufacturer's written instructions and as needed to prevent damage to glass and glazing materials from condensation, temperature changes, direct exposure to sun, or other causes.

1.7 PROJECT CONDITIONS

- A. Environmental Limitations: Do not proceed with glazing when ambient and substrate temperature conditions are outside limits permitted by glazing material manufacturers and when glazing channel substrates are wet from rain, frost, condensation, or other causes.
 - 1. Do not install liquid glazing sealants when ambient and substrate temperature conditions are outside limits permitted by glazing sealant manufacturer or below 40 deg F (4.4 deg C).

1.8 WARRANTY

- A. General Warranty: Special warranties specified in this Article shall not deprive Owner of other rights Owner may have under other provisions of the Contract Documents and shall be in addition to, and run concurrent with, other warranties made by Contractor under requirements of the Contract Documents.

- B. Manufacturer's Special Warranty on Coated-Glass Products: Written warranty, made out to Owner and signed by coated-glass manufacturer agreeing to furnish replacements for those coated-glass units that deteriorate as defined in "Definitions" Article, f.o.b. the nearest shipping point to Project site, within specified warranty period indicated below.
 - 1. Warranty Period: 10 years from date of Substantial Completion.
- C. Manufacturer's Special Warranty on Insulating Glass: Written warranty, made out to Owner and signed by insulating-glass manufacturer agreeing to furnish replacements for insulating-glass units that deteriorate as defined in "Definitions" Article, f.o.b. the nearest shipping point to Project site, within specified warranty period indicated below.
 - 1. Warranty Period: 10 years from date of Substantial Completion.
- D. Manufacturer's Special Warranty on Laminated Glass: Written warranty, made out to Owner and signed by laminated-glass manufacturer agreeing to furnish replacements for laminated-glass units that deteriorate as defined in "Definitions" Article, f.o.b. the nearest shipping point to Project site, within specified warranty period indicated below.
 - 1. Warranty Period: Five years from date of Substantial Completion.
 - 2. Warranty Period for Security Glass: Ten years from date of Substantial Completion.
- E. Manufacturer's Special Warranty on Fire Rated Glass: Written warranty, made out to Owner and signed by insulating-glass manufacturer agreeing to furnish replacements for insulating-glass units that deteriorate as defined in "Definitions" Article, f.o.b. the nearest shipping point to Project site, within specified warranty period indicated below.
 - 1. Warranty Period: 5 years from date of Substantial Completion.

PART 2 - PRODUCTS

2.1 PRIMARY FLOAT GLASS

- A. Float Glass: ASTM C 1036, Type I (transparent glass, flat), Quality q3 (glazing select); Class 1 unless otherwise indicated in schedules at the end of Part 3.

2.2 HEAT-TREATED FLOAT GLASS

- A. Fabrication Process: By horizontal (roller-hearth) process with roll-wave distortion parallel to bottom edge of glass as installed, unless otherwise indicated.
- A. Heat-Treated Float Glass: ASTM C 1048; Type I (transparent glass, flat); Quality q3 (glazing select); class, kind, and condition as indicated in schedules at the end of Part 3.

2.3 COATED FLOAT GLASS

- A. General: Provide coated glass complying with requirements indicated in this Article and in schedules at the end of Part 3.
 - 1. Provide Kind HS (heat-strengthened) coated float glass in place of coated annealed glass where needed to resist thermal stresses induced by differential shading of individual glass lites and to comply with glass design requirements specified in "Performance Requirements" Article. Provide Kind FT (fully tempered) where safety glass is indicated.
- B. Sputter-Coated Float Glass: ASTM C 1376, float glass with metallic-oxide or -nitride coating deposited by vacuum deposition process after manufacture and heat treatment (if any), and complying with other requirements specified in schedules at the end of Part 3.
 - 1. Basis of Design Product: Solarban 70 by Vitro Architectural Glass (formerly PPG Industries, Inc.) or equal.
- C. Silicone-Coated Spandrel Glass: ASTM C 1048, Condition C, Type I, Quality-Q3, and complying with other requirements specified.
 - 1. Basis of Design Product: Opacicoat-300 by ICD Coatings or equal
 - 2. Color(s): As selected by Architect from manufacturer's full range.
 - 3. Thickness of Coating: 6.50 mils dry, for fallout protection
- D. Ceramic-Coated Silk Screened Fritted Glass: ASTM C 1048, Type I, Condition B, Quality-Q3, and complying with other requirements specified.
 - 1. Basis of Design Product: Viraspan by Viracon or equal
 - 2. Color(s): As scheduled.
 - 3. Pattern: As scheduled.

2.4 FIRE RATED GLAZING

- A. Fire-Rated Glazing Product (Laminated Ceramic Glazing Material): Proprietary Category I and II safety glazing product in the form of 2 lites of clear ceramic glazing material laminated together to produce a laminated lite of 5/16-inch nominal thickness; polished on both surfaces, weighing 4 lb/sq. ft.; and as follows:
 - 1. Fire-Protection Rating: As indicated for the assembly in which glazing material is installed, and permanently labeled by a testing and inspecting agency acceptable to authorities having jurisdiction.
 - 2. Polished on both surfaces, transparent.
 - 3. Product: "FireLite Plus Premium" by Nippon Electric Glass Co., Ltd., and distributed by Technical Glass Products.
- B. Fire-Rated Glazing Product (Laminated Ceramic Glazing Material): Proprietary Category I and II safety glazing product in the form of multiple sheets of Pilkington Optiwhite high visible light transmission glass laminated with an intumescent interlayer.

1. Fire-Protection Rating: As indicated for the assembly in which glazing material is installed, and permanently labeled by a testing and inspecting agency acceptable to authorities having jurisdiction.
2. Interior Glazing Thickness for 90 Minute Openings: Single lite, 1-7/16" thick (Product Designation 90-102 with minimum 84% daylight transmission).
3. Polished on both surfaces
4. Product: "Pilkington Pyrostop" by Nippon Sheet Glass Co., Ltd., and distributed by Technical Glass Products.

2.5 LAMINATED GLASS

- A. Laminated Glass: Comply with ASTM C 1172 for kinds of laminated glass indicated and other requirements specified, including those in the Laminated-Glass Schedule at the end of Part 3.
- B. Interlayer: Interlayer material as indicated below, clear or in colors, and of thickness indicated with a proven record of no tendency to bubble, discolor, or lose physical and mechanical properties after laminating glass lites and installation.
 1. Interlayer Material: Polyvinyl butyral sheets
 2. Interlayer Thickness: .030" except provide .060" thickness for laminating two lites of heat strengthened glass together, and where scheduled.
 3. Interlayer Color: Clear.
- C. Laminating Process: Fabricate laminated glass to produce glass free of foreign substances and air or glass pockets as follows:
 1. Laminate lites with polyvinyl butyral interlayer in autoclave with heat plus pressure.
- D. Security Glazing: laminated glass product consisting of outer layers of glass with a custom security, heat strengthened, chemically bonded core. The patent pending core reacts to physical abuse like metal and will bend, but will not tear or rip like other security products. Security glazing shall be designed to replace glass used in openings that would normally be glazed with 1/4" or 5/16" glass.
 1. Basis of Design Product: SG5 by School Guard glass, or equal.
 2. Ratings:
 - a. UL972
 - b. 5-aa1 rated for 12 minutes
 - c. ASTM F1233 Class 1.4 (tested to 5 minutes of class 1.5 until failure)

2.6 INSULATING GLASS

- A. Insulating-Glass Units: Preassembled units consisting of sealed lites of glass separated by a dehydrated interspace, and complying with ASTM E 774 for Class CBA units and with requirements specified in this Article and in the Insulating-Glass Schedule at the end of Part 3.

1. Provide Kind HS (heat-strengthened) float glass in place of annealed glass where needed to resist thermal stresses induced by differential shading of individual glass lites and to comply with glass design requirements specified in "Performance Requirements" Article. Provide Kind FT (fully tempered) where safety glass is indicated. Provide heat soaked glass where scheduled.
- B. Overall Unit Thickness and Thickness of Each Lite: Dimensions indicated in the Insulating-Glass Schedule at the end of Part 3 are nominal and the overall thicknesses of units are measured perpendicularly from outer surfaces of glass lites at unit's edge.
- C. Sealing System: Dual seal, with primary and secondary sealants as follows:
 1. Manufacturer's standard sealants.
- D. Spacer Specifications: Manufacturer's standard spacer material and construction complying with the following requirements:
 1. Aluminum with mill or clear-anodized finish.
 2. Desiccant: Molecular sieve or silica gel, or blend of both.
 3. Corner Construction: Manufacturer's standard corner construction.

2.7 ELASTOMERIC GLAZING SEALANTS

- A. General: Provide products of type indicated, complying with the following requirements:
 1. Compatibility: Select glazing sealants that are compatible with one another and with other materials they will contact, including glass products, seals of insulating-glass units, and glazing channel substrates, under conditions of service and application, as demonstrated by sealant manufacturer based on testing and field experience.
 2. Suitability: Comply with sealant and glass manufacturers' written instructions for selecting glazing sealants suitable for applications indicated and for conditions existing at time of installation.
 3. Colors of Exposed Glazing Sealants: As selected by Architect from manufacturer's full range for this characteristic.
 4. Field-applied sealants shall have a VOC content of not more than 250 g/L.
- B. Single-Component Neutral-Curing Silicone Sealant: ASTM C 920; Type S; Grade NS; Class 50; Uses NT, M, G, A, and, as applicable to joint substrates indicated, O.
 1. Products:
 - a. Dow Corning Corporation; 791.
 - b. Dow Corning Corporation; 795.
 - c. GE Silicones; SilPruf NB SCS9000.
 - d. GE Silicones; UltraPruf II SCS2900.
 - e. Pecora Corporation; 865.
 - f. Pecora Corporation; 895.
 - g. Pecora Corporation; 898

- C. Glazing Sealants for Fire-Resistive and Fire Protective Glazing Products: Identical to products used in test assemblies to obtain fire-protection rating.

2.8 GLAZING TAPES

- A. Back-Bedding Mastic Glazing Tape: Preformed, butyl-based elastomeric tape with a solids content of 100 percent; nonstaining and nonmigrating in contact with nonporous surfaces; with or without spacer rod as recommended in writing by tape and glass manufacturers for application indicated; packaged on rolls with a release paper backing; and complying with ASTM C 1281 and AAMA 806.3 tape, for glazing applications in which tape is subject to continuous pressure.
- B. Expanded Cellular Glazing Tape: Closed-cell, PVC foam tape; factory coated with adhesive on both surfaces; packaged on rolls with release liner protecting adhesive; and complying with AAMA 800 for the following types:
 - 1. Type 1, for glazing applications in which tape acts as the primary sealant.
 - 2. Type 2, for glazing applications in which tape is used in combination with a full bead of liquid sealant.
- C. Glazing Tapes for Fire-Resistive and Fire Protective Glazing Products: Identical to products used in test assemblies to obtain fire-protection rating.

2.9 GLAZING GASKETS

- A. Glazing gaskets for storefront and entrance systems are specified in Division 08 Section "Aluminum-Framed Storefronts and Entrances".
- B. Glazing gaskets for glazed aluminum curtain wall systems are specified in Division 08 Section "Glazed Aluminum Curtain Walls."
- C. Glazing gaskets for all other sliding and swinging glazed doors and panels systems and glazed walls are specified in their respective Division 08 Sections.
- D. Glazing gaskets for metal-framed skylights are specified in Division 08 Section "Metal-Framed Skylights."

2.10 MISCELLANEOUS GLAZING MATERIALS

- A. General: Provide products of material, size, and shape complying with referenced glazing standard, requirements of manufacturers of glass and other glazing materials for application indicated, and with a proven record of compatibility with surfaces contacted in installation.
- B. Cleaners, Primers, and Sealers: Types recommended by sealant or gasket manufacturer.
- C. Setting Blocks: Silicone elastomeric material with a Shore A durometer hardness of 85, plus or minus 5.

- D. Spacers: Elastomeric blocks or continuous extrusions with a Shore A durometer hardness required by glass manufacturer to maintain glass lites in place for installation indicated.
- E. Edge Blocks: Elastomeric material of hardness needed to limit glass lateral movement (side walking).
- F. Cylindrical Glazing Sealant Backing: ASTM C 1330, Type O (open-cell material), of size and density to control glazing sealant depth and otherwise produce optimum glazing sealant performance.
- G. Perimeter Insulation for Fire-Resistive Glazing: Identical to product used in test assembly to obtain fire-resistance rating

2.11 FABRICATION OF GLASS AND OTHER GLAZING PRODUCTS

- A. Fabricate glass and other glazing products in sizes required to glaze openings indicated for Project, with edge and face clearances, edge and surface conditions, and bite complying with written instructions of product manufacturer and referenced glazing standard, to comply with system performance requirements.
- B. Grind smooth and polish exposed glass edges.

PART 3 - EXECUTION

3.1 EXAMINATION

- A. Examine framing glazing, with Installer present, for compliance with the following:
 - 1. Manufacturing and installation tolerances, including those for size, squareness, and offsets at corners.
 - 2. Presence and functioning of weep system.
 - 3. Minimum required face or edge clearances.
 - 4. Effective sealing between joints of glass-framing members.
- B. Proceed with installation only after unsatisfactory conditions have been corrected.

3.2 PREPARATION

- A. Clean glazing channels and other framing members receiving glass immediately before glazing. Remove coatings not firmly bonded to substrates.

3.3 GLAZING, GENERAL

- A. Comply with combined written instructions of manufacturers of glass, sealants, gaskets, and other glazing materials, unless more stringent requirements are indicated, including those in referenced glazing publications.

- B. Glazing channel dimensions, as indicated on Drawings, provide necessary bite on glass, minimum edge and face clearances, and adequate sealant thicknesses, with reasonable tolerances. Adjust as required by Project conditions during installation.
- C. Protect glass edges from damage during handling and installation. Remove damaged glass from Project site and legally dispose of off Project site. Damaged glass is glass with edge damage or other imperfections that, when installed, could weaken glass and impair performance and appearance.
- D. Apply primers to joint surfaces where required for adhesion of sealants, as determined by preconstruction sealant-substrate testing.
- E. Install setting blocks in sill rabbets, sized and located to comply with referenced glazing publications, unless otherwise required by glass manufacturer. Set blocks in thin course of compatible sealant suitable for heel bead.
- F. Do not exceed edge pressures stipulated by glass manufacturers for installing glass lites.
- G. Provide spacers for glass lites where the length plus width is larger than 50 inches (1270 mm) as follows:
 - 1. Locate spacers directly opposite each other on both inside and outside faces of glass. Install correct size and spacing to preserve required face clearances, unless gaskets and glazing tapes are used that have demonstrated ability to maintain required face clearances and to comply with system performance requirements.
 - 2. Provide 1/8-inch (3-mm) minimum bite of spacers on glass and use thickness equal to sealant width. With glazing tape, use thickness slightly less than final compressed thickness of tape.
- H. Provide edge blocking where indicated or needed to prevent glass lites from moving sideways in glazing channel, as recommended in writing by glass manufacturer and according to requirements in referenced glazing publications.
- I. Set glass lites in each series with uniform pattern, draw, bow, and similar characteristics.
- J. Where wedge-shaped gaskets are driven into one side of channel to pressurize sealant or gasket on opposite side, provide adequate anchorage so gasket cannot walk out when installation is subjected to movement.
- K. Square cut wedge-shaped gaskets at corners and install gaskets in a manner recommended by gasket manufacturer to prevent corners from pulling away; seal corner joints and butt joints with sealant recommended by gasket manufacturer.

3.4 TAPE GLAZING

- A. Position tapes on fixed stops so that, when compressed by glass, their exposed edges are flush with or protrude slightly above sightline of stops.

- B. Install tapes continuously, but not necessarily in one continuous length. Do not stretch tapes to make them fit opening.
- C. Where framing joints are vertical, cover these joints by applying tapes to heads and sills first and then to jambs. Where framing joints are horizontal, cover these joints by applying tapes to jambs and then to heads and sills.
- D. Place joints in tapes at corners of opening with adjoining lengths butted together, not lapped. Seal joints in tapes with compatible sealant approved by tape manufacturer.
- E. Do not remove release paper from tape until just before each glazing unit is installed.
- F. Apply heel bead of elastomeric sealant.
- G. Center glass lites in openings on setting blocks and press firmly against tape by inserting dense compression gaskets formed and installed to lock in place against faces of removable stops. Start gasket applications at corners and work toward centers of openings.
- H. Apply cap bead of elastomeric sealant over exposed edge of tape.

3.5 GASKET GLAZING (DRY)

- A. Fabricate compression gaskets in lengths recommended by gasket manufacturer to fit openings exactly, with stretch allowance during installation.
- B. Insert soft compression gasket between glass and frame or fixed stop so it is securely in place with joints miter cut and bonded together at corners.
- C. Center glass lites in openings on setting blocks and press firmly against soft compression gasket by inserting dense compression gaskets formed and installed to lock in place against faces of removable stops. Start gasket applications at corners and work toward centers of openings. Compress gaskets to produce a weathertight seal without developing bending stresses in glass. Seal gasket joints with sealant recommended by gasket manufacturer.
- D. Install gaskets so they protrude past face of glazing stops.

3.6 SEALANT GLAZING (WET)

- A. Install continuous spacers, or spacers combined with cylindrical sealant backing, between glass lites and glazing stops to maintain glass face clearances and to prevent sealant from extruding into glass channel and blocking weep systems until sealants cure. Secure spacers or spacers and backings in place and in position to control depth of installed sealant relative to edge clearance for optimum sealant performance.
- B. Force sealants into glazing channels to eliminate voids and to ensure complete wetting or bond of sealant to glass and channel surfaces.
- C. Tool exposed surfaces of sealants to provide a substantial wash away from glass.

3.7 PROTECTION AND CLEANING

- A. Protect exterior glass from damage immediately after installation by attaching crossed streamers to framing held away from glass. Do not apply markers to glass surface. Remove nonpermanent labels, and clean surfaces.
- B. Protect glass from contact with contaminating substances resulting from construction operations, including weld splatter. If, despite such protection, contaminating substances do come into contact with glass, remove them immediately as recommended by glass manufacturer.
- C. Examine glass surfaces adjacent to or below exterior concrete and other masonry surfaces at frequent intervals during construction, but not less than once a month, for build-up of dirt, scum, alkaline deposits, or stains; remove as recommended by glass manufacturer.
- D. Remove and replace glass that is broken, chipped, cracked, abraded, or damaged in any way, including natural causes, accidents, and vandalism, during construction period.
- E. Wash glass on both exposed surfaces in each area of Project not more than four days before date scheduled for inspections that establish date of Substantial Completion. Wash glass as recommended by glass manufacturer.

3.8 GLASS SCHEDULE

A. Exterior Glazing:

- 1. Exterior Doors: Provide 1 inch insulated tempered glass as follows:
 - a. Outboard Lite: 1/4-inch thick clear, fully tempered (Kind FT) glass, low-E coated on the second surface.
 - 1) Low-Emissivity Sputter Coating: Solarban 70; by Vitro Architectural Glass (formerly PPG Industries, Inc.)
 - b. Air Space: 1/2 inch, argon filled.
 - c. Inboard Lite: 1/4-inch thick clear, fully tempered (Kind FT) glass
 - d. Performance Characteristics:
 - 1) Visible Light Transmittance: Min 64%.
 - 2) Winter Nighttime U-Value: Max. 0.24
 - 3) Solar Heat Gain Coefficient (SHGC): Max. 0.27
 - 4) Light to Solar Gain: 2.37
 - 5) Outdoor Visible Light Reflectance: 12%
- 2. Bottom Panels of Storefront and Entrance Framing and Bottom Panels of Curtainwall Framing (including sidelites and transoms): Provide 1 inch insulated tempered glass as follows:
 - a. Outboard Lite: 1/4-inch thick clear, fully tempered (Kind FT) glass, low-E coated on the second surface.

- 1) Low-Emissivity Sputter Coating: Solarban 70; by Vitro Architectural Glass (formerly PPG Industries, Inc.)
 - b. Air Space: 1/2 inch, argon filled.
 - c. Inboard Lite: 1/4-inch thick clear, fully tempered (Kind FT) glass
 - d. Performance Characteristics:
 - 1) Visible Light Transmittance: Min 64%.
 - 2) Winter Nighttime U-Value: Max. 0.24
 - 3) Solar Heat Gain Coefficient (SHGC): Max. 0.27
 - 4) Light to Solar Gain: 2.37
 - 5) Outdoor Visible Light Reflectance: 12%
3. Storefront Framing used for Fixed Windows, Operable Vents and Upper Panels of Curtainwall Framing and Storefront Framing: Provide 1 inch insulated glass as follows:
- a. Outboard Lite: 1/4-inch thick clear, annealed glass, low-E coated on the second surface.
 - 1) Low-Emissivity Sputter Coating: Solarban 70; by Vitro Architectural Glass (formerly PPG Industries, Inc.)
 - b. Air Space: 1/2 inch, argon filled.
 - c. Inboard Lite: 1/4-inch thick clear, annealed glass
 - d. Performance Characteristics:
 - 1) Visible Light Transmittance: Min 64%.
 - 2) Winter Nighttime U-Value: Max. 0.24
 - 3) Solar Heat Gain Coefficient (SHGC): Max. 0.27
 - 4) Light to Solar Gain: 2.37
 - 5) Outdoor Visible Light Reflectance: 12%
4. Curtainwall and Storefront Spandrel Glazing: Provide 1 inch insulated glass, as follows:
- a. Outboard Lite: 1/4-inch thick clear, heat strengthened (Kind HS) float glass, low-E coated on the second surface.
 - 1) Low-Emissivity Sputter Coating: Solarban 70; by Vitro Architectural Glass (formerly PPG Industries, Inc.)
 - b. Air Space: 1/2 inch, argon filled.
 - c. Inboard Lite: 1/4-inch thick clear, heat strengthened (Kind HS) float glass, with silicone coating on the #4 surface
 - 1) Silicone Coating: Opacicoat-300 by ICD Coatings
 - 2) Color: As selected by Architect.
5. Entrance Framing and Doors at Gymnasium Locations: Provide 1 inch insulated laminated and tempered glass units as follows:
- a. Outboard Lite: 1/4-inch thick clear, fully tempered (Kind FT) low-E coated on the second surface.

- 1) Low-Emissivity Sputter Coating: Solarban 70; by Vitro Architectural Glass (formerly PPG Industries, Inc.)
 - b. Air Space: 1/2 inch, argon filled.
 - c. Inboard Lite: 1/4-inch thick clear, laminated glass.
 - d. Performance Characteristics:
 - 1) Visible Light Transmittance: Min 64%.
 - 2) Winter Nighttime U-Value: Max. 0.24
 - 3) Solar Heat Gain Coefficient (SHGC): Max. 0.27
 - 4) Light to Solar Gain: 2.37
 - 5) Outdoor Visible Light Reflectance: 12%
6. Clerestory Windows at Gymnasium Locations: Provide 1 inch insulated laminated and heat strengthened glass units as follows:
- a. Outboard Lite: 1/4-inch thick clear, heat strengthened (Kind HS) low-E coated on the second surface.
 - 1) Low-Emissivity Sputter Coating: Solarban 70; by Vitro Architectural Glass (formerly PPG Industries, Inc.)
 - b. Air Space: 1/2 inch, argon filled.
 - c. Inboard Lite: 1/4-inch thick clear, laminated glass with white translucent interlayer (by Viracon or equal.)
7. Storefront Used for Fixed Windows at Transom Locations: Provide 1-inch insulated fritted glass, as follows:
- a. Outboard Lite: 1/4-inch thick clear, heat strengthened (Kind HS) float glass, low-E coated on the second surface and ceramic-coated silk screen fritted pattern on second surface.
 - 1) Low-Emissivity Sputter Coating: Solarban 70; by Vitro Architectural Glass (formerly PPG Industries, Inc.)
 - 2) Ceramic-Coated Silk Screened Pattern: Viraspan 30% or 40% coverage (as selected by Architect), 1/8" dot pattern
 - a) Pattern: Screen 5006
 - b) Color: White opaque frit V175
 - b. Air Space: 1/2 inch, argon filled.
 - c. Inboard Lite: 1/4-inch thick clear, annealed glass.
8. Storefront Framing used for Fixed Windows and Operable Vents (for acoustic ratings, where indicated): Provide 1-3/4 inch triple glazed insulated glass as follows:
- a. Outboard Lite: 1/4-inch thick clear, annealed glass, low-E coated on the second surface.
 - 1) Low-Emissivity Sputter Coating: Solarban 70; by Vitro Architectural Glass (formerly PPG Industries, Inc.)
 - b. Air Space: 1/2 inch, argon filled.

- c. Center Lite: 1/4-inch thick clear, annealed glass
 - d. Air Space: 1/2 inch, argon filled.
 - e. Inboard Lite: 1/4-inch thick clear, annealed glass
9. Metal-Framed Skylights: Provide 1-7/16 inch insulated glass, as follows:
- a. Outboard Lite: 3/8-inch thick clear, heat strengthened (Kind HS) float glass, low-E coated on the second surface and ceramic-coated silk screen fritted pattern on second surface.
 - 1) Low-Emissivity Sputter Coating: Solarban 70; by Vitro Architectural Glass (formerly PPG Industries, Inc.).
 - 2) Ceramic-Coated Silk Screened Pattern: Viraspan 30% or 40% coverage (as selected by Architect), 1/8" dot pattern
 - a) Pattern: Screen 5006
 - b) Color: White opaque frit V175
 - b. Air Space: 1/2 inch, argon filled.
 - c. Inboard Lite: 9/16-inch thick clear, laminated glass.
 - 1) Provide two lites of annealed glass laminated together unless two lites of heat strengthened glass are required for strength.
 - 2) Interlayer Thickness: 0.060"
10. Insulated Tempered Glass for Folding Glass Storefront: Provide 15/16 inch insulated glass, as follows:
- a. Outboard Lite: 1/4-inch thick clear, fully tempered (Kind FT) float glass, low-E coated on the second surface.
 - 1) Low-Emissivity Sputter Coating: Solarban 70; by Vitro Architectural Glass (formerly PPG Industries, Inc.)
 - b. Air Space: Argon filled.
 - c. Inboard Lite: 1/4-inch thick clear, fully tempered (Kind FT) float glass

B. Interior Glazing, as Scheduled:

- 1. Non-Fire Rated Doors, Transoms, Sidelights and Borrowed Lights: 1/4 inch clear tempered glass.
- 2. Fire Rated Doors, Transoms, Sidelights and Borrowed Lights: Laminated ceramic glazing material 5/16 inches thick; "FireLite Plus Premium" by Nippon Electric Glass Co., Ltd., and distributed by Technical Glass Products.
- 3. Fire Rated Doors Where Specifically Scheduled: 90 minute Pilkington Pyrostop glazing material, 1-7/16" thick, by Nippon Electric Glass Co., Ltd., and distributed by Technical Glass Products.
- 4. Acoustic Rated Wood Doors: Dual glazed acoustic glazing with 1/4" and 3/8" laminated glass; adjust as required to match tested door assembly used on project.
- 5. Security Glazing for Doors and Transaction Windows as Scheduled: SG5 laminated glass product by School Guard Glass, or approved equal.

END OF SECTION 088000

SECTION 089000 - LOUVERS AND VENTS

PART 1 - GENERAL

1.1 SUMMARY

A. This Section Includes the Following:

1. Fixed, extruded-aluminum louvers.

B. Related Sections Include the Following:

1. Division 07 Section "Joint Sealants" for sealants installed in perimeter joints between louver frames and adjoining construction.
2. Division 23 Sections for louvers that are a part of mechanical equipment.

1.2 DEFINITIONS

A. Louver Terminology: Definitions of terms for metal louvers contained in AMCA 501 apply to this Section unless otherwise defined in this Section or in referenced standards.

B. Drainable-Blade Louver: Louver with blades having gutters that collect water and drain it to channels in jambs and mullions, which carry it to bottom of unit and away from opening.

1.3 PERFORMANCE REQUIREMENTS

A. Structural Performance: Provide louvers capable of withstanding the effects of gravity loads and the following loads and stresses within limits and under conditions indicated without permanent deformation of louver components, noise or metal fatigue caused by louver blade rattle or flutter, or permanent damage to fasteners and anchors. Wind pressures shall be considered to act on vertical projection of louvers.

1. Wind Loads: Uniform pressure (velocity pressure) of 18 lbf per sq. ft. acting inwards.

B. Thermal Movements: Provide louvers that allow for thermal movements resulting from the following maximum change (range) in ambient and surface temperatures by preventing buckling, opening of joints, overstressing of components, failure of connections, and other detrimental effects. Base engineering calculation on surface temperatures of materials due to both solar heat gain and nighttime-sky heat loss.

1. Temperature Change (Range): 120 deg F (67 deg C), ambient; 180 deg F (100 deg C), material surfaces.

C. Air-Performance, Water-Penetration, Air-Leakage, and Wind-Driven Rain Ratings: Provide louvers complying with performance requirements indicated, as demonstrated by

testing manufacturer's stock units identical to those provided, except for length and width according to AMCA 500-L.

1.4 SUBMITTALS

- A. Product Data: For each type of product indicated. For louvers specified to bear AMCA seal, include printed catalog pages showing specified models with appropriate AMCA Certified Ratings Seals.
- B. Shop Drawings: For louvers and accessories. Include plans, elevations, sections, details, and attachments to other Work. Show blade profiles, angles, and spacing.
- C. Samples for Verification: For each type of metal finish required.
- D. Product Certificates: Signed by manufacturers stating the location of the material manufacturer and the distance from the manufacturer to the Project site.

1.5 QUALITY ASSURANCE

- A. Source Limitations: Obtain louvers and vents through one source from a single manufacturer where indicated to be of same type, design, or factory-applied color finish.
- B. SMACNA Standard: Comply with recommendations in SMACNA's "Architectural Sheet Metal Manual" for fabrication, construction details, and installation procedures.

1.6 PROJECT CONDITIONS

- A. Field Measurements: Verify louver openings by field measurements before fabrication and indicate measurements on Shop Drawings.

PART 2 - PRODUCTS

2.1 MANUFACTURERS

- A. In other Part 2 articles where titles below introduce lists, the following requirements apply for product selection:
 - 1. Basis-of-Design Product: The design for each louver is based on the product named. Subject to compliance with requirements, provide either the named product or approved equivalent by one of the other manufacturers specified.
 - a. Construction Specialties.
 - b. Airolite Co.
 - c. Reliable Metal Products.
 - d. Industrial Acoustics Company.

2.2 MATERIALS

- A. Aluminum Extrusions: ASTM B 221 (ASTM B 221M), alloy 6063-T5 or T-52.T-52.

- B. Aluminum Sheet: ASTM B 209 (ASTM B 209M), alloy 3003 or 5005 with temper as required for forming, or as otherwise recommended by metal producer for required finish.
- C. Aluminum Castings: ASTM B 26/B 26M, alloy 319.
- D. Fasteners: Of same basic metal and alloy as fastened metal or 300 Series stainless steel, unless otherwise indicated. Do not use metals that are incompatible with joined materials.
 - 1. Use types and sizes to suit unit installation conditions.
 - 2. Use Phillips flat-head screws for exposed fasteners, unless otherwise indicated.
- E. Postinstalled Fasteners for Concrete and Masonry: Torque-controlled expansion anchors, made from stainless-steel components, with capability to sustain, without failure, a load equal to 4 times the loads imposed, for concrete, or 6 times the load imposed, for masonry, as determined by testing per ASTM E 488, conducted by a qualified independent testing agency.
- F. Bituminous Paint: Cold-applied asphalt emulsion complying with ASTM D 1187.

2.3 FABRICATION, GENERAL

- A. Assemble louvers in factory to minimize field splicing and assembly. Disassemble units as necessary for shipping and handling limitations. Clearly mark units for reassembly and coordinated installation.
- B. Maintain equal louver blade spacing to produce uniform appearance.
- C. Fabricate frames, including integral sills, to fit in openings of sizes indicated, with allowances made for fabrication and installation tolerances, adjoining material tolerances, and perimeter sealant joints.
- D. Include supports, anchorages, and accessories required for complete assembly.
- E. Where indicated, provide subsills made of same material as louvers or extended sills for recessed louvers.
- F. Join frame members to each other and to fixed louver blades with fillet welds, threaded fasteners, or both, as standard with louver manufacturer, concealed from view, unless otherwise indicated or size of louver assembly makes bolted connections between frame members necessary.

2.4 FIXED, EXTRUDED-ALUMINUM LOUVERS

- A. Horizontal, Single Drainable-Blade Louver:
 - 1. Basis-of-Design Product: Ruskin Model ELF375DX Drainable Stationary Louvers.
 - 2. Finish: Fluoropolymer 3-Coat System.
 - 3. Depth: 4-inches.

4. Frame and Blade Nominal Thickness: As required to comply with structural performance requirements, but not less than 0.081 inch.
5. Mullion Type: Fixed, hidden mullions shall allow for continuous line appearance for up to 120"
6. Performance Requirements:
 - a. Free Area: 54%.
 - b. Point of Beginning Water Penetration: 873 fpm at .01 oz/sf.
7. Sizes: Refer to Contract Drawings for sizes, configurations, and locations.
8. AMCA Seal: Mark units with AMCA Certified Ratings Seal.

2.5 LOUVER SCREENS

- A. General: Provide screen at each exterior louver.
 1. Screen Location for Fixed Louvers: Interior face.
 2. Screening Type: Bird screening. NO Insect screening allowed.
- B. Secure screens to louver frames with stainless-steel machine screws, spaced a maximum of 6 inches (150 mm) from each corner and at 12 inches (300 mm) o.c.
- C. Louver Screen Frames: Fabricate with mitered corners to louver sizes indicated.
 1. Metal: Same kind and form of metal as indicated for louver to which screens are attached. Reinforce extruded-aluminum screen frames at corners with clips.
 2. Finish: Same finish as louver frames to which louver screens are attached.
- D. Louver Screening for Aluminum Louvers:
 1. Bird Screening: Aluminum, 1/2-inch- (12.7-mm-) square mesh, 0.063-inch (1.6-mm) wire.

2.6 BLANK-OFF PANELS

- A. Insulated, Blank-Off Panels: Laminated panels consisting of an insulating core surfaced on back and front with metal sheets and attached to back of louver.
 1. Thickness: 1 inch (25 mm).
 2. Metal Facing Sheets: Aluminum sheet, not less than 0.032-inch (0.81-mm) nominal thickness.
 3. Insulating Core: Rigid, glass-fiber-board insulation.
 4. Edge Treatment: Trim perimeter edges of blank-off panels with louver manufacturer's standard channel frames, with corners mitered and with same finish as panels.
 5. Seal perimeter joints between panel faces and louver frames with gaskets or sealant.
 6. Panel Finish: As selected by Architect.
 7. Attach blank-off panels with clips.

2.7 FINISHES, GENERAL

- A. Comply with NAAMM's "Metal Finishes Manual for Architectural and Metal Products" for recommendations for applying and designating finishes.
- B. Finish louvers after assembly.

2.8 ALUMINUM FINISHES

- A. Finish designations prefixed by AA comply with system established by the Aluminum Association for designating aluminum finishes.
- B. High-Performance Organic Finish: AA-C12C42R1x (Chemical Finish: cleaned with inhibited chemicals; Chemical Finish: acid-chromate-fluoride-phosphate conversion coating; Organic Coating: as specified below). Prepare, pretreat, and apply coating to exposed metal surfaces to comply with coating and resin manufacturers' written instructions.
 - 1. Fluoropolymer 3-Coat System: Manufacturer's standard 3-coat, thermocured system consisting of specially formulated inhibitive primer, fluoropolymer color coat and clear topcoat containing not less than 70 percent polyvinylidene fluoride resin by weight; complying with AAMA 2605.
 - a. Color(s): As selected by Architect.

PART 3 - EXECUTION

3.1 EXAMINATION

- A. Examine substrates and openings, with Installer present, for compliance with requirements for installation tolerances and other conditions affecting performance.
 - 1. Proceed with installation only after unsatisfactory conditions have been corrected.

3.2 PREPARATION

- A. Coordinate setting drawings, diagrams, templates, instructions, and directions for installation of anchorages that are to be embedded in concrete or masonry construction. Coordinate delivery of such items to Project site.

3.3 INSTALLATION

- A. Locate and place louvers level, plumb, and at indicated alignment with adjacent work.
- B. Use concealed anchorages where possible. Provide brass or lead washers fitted to screws where required to protect metal surfaces and to make a weathertight connection.
- C. Form closely fitted joints with exposed connections accurately located and secured.

- D. Provide perimeter reveals and openings of uniform width for sealants and joint fillers, as indicated.
- E. Repair finishes damaged by cutting, welding, soldering, and grinding. Restore finishes so no evidence remains of corrective work. Return items that cannot be refinished in the field to the factory, make required alterations, and refinish entire unit or provide new units.
- F. Protect galvanized and nonferrous-metal surfaces from corrosion or galvanic action by applying a heavy coating of bituminous paint on surfaces that will be in contact with concrete, masonry, or dissimilar metals.
- G. Install concealed gaskets, flashings, joint fillers, and insulation as louver installation progresses, where weathertight louver joints are required. Comply with Division 7 Section "Joint Sealants" for sealants applied during louver installation.

3.4 ADJUSTING AND CLEANING

- A. Clean exposed surfaces of louvers that are not protected by temporary covering, to remove fingerprints and soil during construction period. Do not let soil accumulate until final cleaning.
- B. Before final inspection, clean exposed surfaces with water and a mild soap or detergent not harmful to finishes. Thoroughly rinse surfaces and dry.
- C. Restore louvers damaged during installation and construction so no evidence remains of corrective work. If results of restoration are unsuccessful, as determined by Architect, remove damaged units and replace with new units.
 - 1. Touch up minor abrasions in finishes with air-dried coating that matches color and gloss of, and is compatible with, factory-applied finish coating.

END OF SECTION 089000

SECTION 092116.23 - GYPSUM BOARD SHAFT WALL ASSEMBLIES

PART 1 - GENERAL

1.1 SUMMARY

- A. Section Includes: Gypsum board shaft wall assemblies.

1.2 ACTION SUBMITTALS

- A. Product Data: For each component of gypsum board shaft wall assembly.

1.3 DELIVERY, STORAGE, AND HANDLING

- A. Store materials inside under cover and keep them dry and protected against weather, condensation, direct sunlight, construction traffic, and other potential causes of damage. Stack panels flat and supported on risers on a flat platform to prevent sagging.

1.4 FIELD CONDITIONS

- A. Environmental Limitations: Comply with ASTM C 840 requirements or with gypsum board manufacturer's written recommendations, whichever are more stringent.
- B. Do not install interior products until installation areas are enclosed and conditioned.
- C. Do not install panels that are wet, moisture damaged, or mold damaged.
 - 1. Indications that panels are wet or moisture damaged include, but are not limited to, discoloration, sagging, and irregular shape.
 - 2. Indications that panels are mold damaged include, but are not limited to, fuzzy or splotchy surface contamination and discoloration.

PART 2 - PRODUCTS

2.1 PERFORMANCE REQUIREMENTS

- A. Fire-Resistance-Rated Assemblies: For fire-resistance-rated assemblies, provide materials and construction identical to those tested in assembly indicated according to ASTM E 119 by an independent testing agency.
- B. STC-Rated Assemblies: Provide materials and construction identical to those of assemblies tested according to ASTM E 90 and classified according to ASTM E 413 by a testing and inspecting agency.

2.2 GYPSUM BOARD SHAFT WALL ASSEMBLIES

- A. Fire-Resistance Rating: 1 hour and 2 hours as indicated.
- B. STC Rating: As indicated.
- C. Studs: Manufacturer's standard profile for repetitive members, corner and end members, and fire-resistance-rated assembly indicated.
 - 1. Depth: 2-1/2 inches (64 mm), 4 inches (102 mm) and 6 inches (152 mm) as indicated on the Partition Type Drawing.
 - 2. Minimum Base-Metal Thickness: 0.033 inch (0.84 mm).
- D. Runner Tracks: Manufacturer's standard J-profile track with manufacturer's standard long-leg length, but at least 2 inches (51 mm) long and matching studs in depth.
 - 1. Minimum Base-Metal Thickness: Matching steel studs.
- E. Room-Side Finish: As indicated.
- F. Shaft-Side Finish: Gypsum shaftliner board, moisture- and mold-resistant Type X.
- G. Insulation: Sound attenuation blankets.

2.3 PANEL PRODUCTS

- A. Panel Size: Provide in maximum lengths and widths available that will minimize joints in each area and that correspond with support system indicated.
- B. Gypsum Shaftliner Board, Type X: ASTM C 1396/C 1396M; manufacturer's proprietary fire-resistive liner panels with paper faces.
 - 1. Products: Subject to compliance with requirements, provide one of the following:
 - a. Lafarge North America, Inc.; Firecheck Type X Shaftliner.
 - b. National Gypsum Company; Gold Bond Brand Fire-Shield Shaftliner.
 - c. USG Corporation; Sheetrock Brand Gypsum Liner Panel.
 - d. American Gypsum; Shaft Liner.
 - 2. Thickness: 1 inch (25.4 mm).
 - 3. Long Edges: Double bevel.
- C. Gypsum Shaftliner Board, Moisture- and Mold-Resistant Type X: ASTM C 1396/C 1396M; manufacturer's proprietary fire-resistive liner panels with moisture- and mold-resistant core and surfaces.
 - 1. Products: Subject to compliance with requirements, provide one of the following:
 - a. Lafarge North America, Inc.; Firecheck Moldcheck Type X Shaftliner.
 - b. National Gypsum Company; Gold Bond Brand Fire-Shield Shaftliner XP.
 - c. USG Corporation; Sheetrock Brand Mold Tough Gypsum Liner Panel.
 - 2. Thickness: 1 inch (25.4 mm).
 - 3. Long Edges: Double bevel.

4. Mold Resistance: ASTM D 3273, score of 10 as rated according to ASTM D 3274.

D. Gypsum Board: As specified in Section 092900 "Gypsum Board."

2.4 NON-LOAD-BEARING STEEL FRAMING

A. Steel Framing Members: Comply with ASTM C 645 requirements for metal unless otherwise indicated.

1. Protective Coating: ASTM A 653/A 653M, G40 (Z120), hot-dip galvanized unless otherwise indicated.

2.5 AUXILIARY MATERIALS

A. General: Provide auxiliary materials that comply with manufacturer's written recommendations.

B. Trim Accessories: Cornerbead, edge trim, and control joints of material and shapes as specified in Section 092900 "Gypsum Board" that comply with gypsum board shaft wall assembly manufacturer's written recommendations for application indicated.

C. Steel Drill Screws: ASTM C 1002 unless otherwise indicated.

D. Track Fasteners: Power-driven fasteners of size and material required to withstand loading conditions imposed on shaft wall assemblies without exceeding allowable design stress of track, fasteners, or structural substrates in which anchors are embedded.

1. Expansion Anchors: Fabricated from corrosion-resistant materials, with capability to sustain, without failure, a load equal to 5 times design load, as determined by testing according to ASTM E 488 conducted by a qualified testing agency.
2. Power-Actuated Anchors: Fastener system of type suitable for application indicated, fabricated from corrosion-resistant materials, with capability to sustain, without failure, a load equal to 10 times design load, as determined by testing according to ASTM E 1190 conducted by a qualified testing agency.

E. Sound Attenuation Blankets: ASTM C 665, Type I (blankets without membrane facing) produced by combining thermosetting resins with mineral fibers manufactured from slag wool, or rock wool; Provide mineral-fiber SAFB.

F. Acoustical Sealant: As specified in Section 079200 "Sealants."

PART 3 - EXECUTION

3.1 EXAMINATION

- A. Examine substrates to which gypsum board shaft wall assemblies attach or abut, with Installer present, including hollow-metal frames, elevator hoistway door frames, cast-in anchors, and structural framing. Examine for compliance with requirements for installation tolerances and other conditions affecting performance.
- B. Examine panels before installation. Reject panels that are wet, moisture damaged, or mold damaged.
- C. Proceed with installation only after unsatisfactory conditions have been corrected.

3.2 PREPARATION

- A. Sprayed Fire-Resistive Materials: Coordinate with gypsum board shaft wall assemblies so both elements of Work remain complete and undamaged. Patch or replace sprayed fire-resistive materials removed or damaged during installation of shaft wall assemblies to comply with requirements specified in Section 078100 "Applied Fireproofing."
- B. After sprayed fire-resistive materials are applied, remove only to extent necessary for installation of gypsum board shaft wall assemblies and without reducing the fire-resistive material thickness below that which is required to obtain fire-resistance rating indicated. Protect remaining fire-resistive materials from damage.

3.3 INSTALLATION

- A. General: Install gypsum board shaft wall assemblies to comply with requirements of fire-resistance-rated assemblies indicated, manufacturer's written installation instructions, and ASTM C 754 other than stud-spacing requirements.
- B. Do not bridge building expansion joints with shaft wall assemblies; frame both sides of expansion joints with furring and other support.
- C. Install supplementary framing in gypsum board shaft wall assemblies around openings and as required for blocking, bracing, and support of gravity and pullout loads of fixtures, equipment, services, heavy trim, furnishings, wall-mounted door stops, and similar items that cannot be supported directly by shaft wall assembly framing.
 - 1. Reinforcing: Where handrails directly attach to gypsum board shaft wall assemblies, provide galvanized steel reinforcing strip with 0.033-inch (0.84-mm) minimum thickness of base metal (uncoated), accurately positioned and secured behind at least one layer of face panel.
- D. Penetrations: At penetrations in shaft wall, maintain fire-resistance rating of shaft wall assembly by installing supplementary steel framing around perimeter of penetration and fire protection behind boxes containing wiring devices, elevator call buttons, elevator floor indicators, and similar items.

- E. Isolate perimeter of gypsum panels from building structure to prevent cracking of panels, while maintaining continuity of fire-rated construction.
- F. Control Joints: Install control joints according to ASTM C 840 and in specific locations approved by Architect while maintaining fire-resistance rating of gypsum board shaft wall assemblies.
 - 1. Install control joints on 30 foot maximum centers, for all partitions, at locations indicated, and as detailed. Align control joints with door frames wherever possible, with space between edges of adjoining gypsum panels, as well as supporting framing behind gypsum panels.
- G. Sound-Rated Shaft Wall Assemblies: Seal gypsum board shaft walls with acoustical sealant at perimeter of each assembly where it abuts other work and at joints and penetrations within each assembly.
- H. Cant Panels: At projections into shaft exceeding 4 inches (102 mm), install 1/2- or 5/8-inch- (13- or 16-mm-) thick gypsum board cants covering tops of projections.
 - 1. Slope cant panels at least 75 degrees from horizontal. Set base edge of panels in adhesive and secure top edges to shaft walls at 24 inches (610 mm) o.c. with screws fastened to shaft wall framing.
 - 2. Where steel framing is required to support gypsum board cants, install framing at 24 inches (610 mm) o.c. and extend studs from the projection to shaft wall framing.
- I. Installation Tolerance: Install each framing member so fastening surfaces vary not more than 1/8 inch (3 mm) from the plane formed by faces of adjacent framing.

3.4 IDENTIFICATION

- A. Fire walls, fire barriers, fire partitions, smoke barriers and smoke partitions or any other wall required to have protected openings or penetrations shall be effectively and permanently identified with signs or stenciling. Such identification shall:
 - 1. Be located in accessible concealed floor, floor-ceiling or attic spaces.
 - 2. Be repeated at intervals not exceeding 30 feet (914 mm) measured horizontally along the wall or partition.
 - 3. Include lettering not less than 0.5 inch (12.7 mm)) in height, incorporating the followings wording: "FIRE AND/OR SMOKE BARRIER—PROTECT ALL OPENINGS," or other wording to reflect the wall type as indicated on the Code Summary Drawings.

3.5 PROTECTION

- A. Protect installed products from damage from weather, condensation, direct sunlight, construction, and other causes during remainder of the construction period.
- B. Remove and replace panels that are wet, moisture damaged, or mold damaged.

1. Indications that panels are wet or moisture damaged include, but are not limited to, discoloration, sagging, and irregular shape.
2. Indications that panels are mold damaged include, but are not limited to, fuzzy or splotchy surface contamination and discoloration.

END OF SECTION 092116.23

SECTION 092216 - NON-STRUCTURAL METAL FRAMING

PART 1 - GENERAL

1.1 SUMMARY

A. Section Includes:

1. Non-load-bearing steel framing systems for interior gypsum board assemblies.
2. Suspension systems for interior gypsum ceilings, soffits, and grid systems.

1.2 ACTION SUBMITTALS

A. Product Data: For each type of product.

PART 2 - PRODUCTS

2.1 DESCRIPTION

- A. Fire-Test-Response Characteristics: For fire-resistance-rated assemblies that incorporate non-load-bearing steel framing, provide materials and construction identical to those tested in assembly indicated according to ASTM E 119 by an independent testing agency.
- B. STC-Rated Assemblies: For STC-rated assemblies, provide materials and construction identical to those tested in assembly indicated according to ASTM E 90 and classified according to ASTM E 413 by an independent testing agency.

2.2 FRAMING SYSTEMS

- A. Framing Members, General: Comply with ASTM C 754 for conditions indicated.
1. Steel Sheet Components: Comply with ASTM C 645 requirements for metal unless otherwise indicated.
 2. Protective Coating: ASTM A 653/A 653M, G40 (Z120), hot-dip galvanized, unless otherwise indicated.
- B. Studs and Runners: ASTM C 645.
1. Steel Studs and Runners:
 - a. Minimum Base-Metal Thickness: 0.0296 inch, 20 ga. (0.752 mm).
 - b. Depth: As scheduled on Drawings for each location.
- C. Slip-Type Head Joints: Provide one of the following:
1. Single Long-Leg Runner System: ASTM C 645 top runner with 2-inch- (51-mm-) deep flanges in thickness not less than indicated for studs, installed with studs friction fit into top runner and with continuous cold rolled channel bridging

- attached to each stud located within 12 inches (305 mm) of the top of studs to provide lateral bracing.
2. Double-Runner System: ASTM C 645 top runners, inside runner with 2-inch- (51-mm-) deep flanges in thickness not less than indicated for studs and fastened to studs, and outer runner sized to friction fit inside runner.
 3. Deflection Track: Steel sheet top runner manufactured to prevent cracking of finishes applied to interior partition framing resulting from deflection of structure above; in thickness not less than indicated for studs and in width to accommodate depth of studs.
 - a. Products: Subject to compliance with requirements, provide one of the following:
 - 1) ClarkDietrich; MaxTrak Slotted Deflection Track
 - 2) Steel Network Inc. (The); VertiClip SLD Series.
 - 3) Telling Industries; True-Action™ Slotted Track.
- D. Flat Strap and Backing Plate: Steel sheet for blocking and bracing in length and width indicated.
1. Minimum Base-Metal Thickness: 0.033 inch, 20 ga. (0.84 mm).
- E. Cold-Rolled Channel Bridging and Bracing: Steel, 0.053-inch (1.34-mm) minimum base-metal thickness, with minimum 1/2-inch- (13-mm-) wide flanges.
1. Depth: 1-1/2 inches (38 mm) unless otherwise indicated.
 2. Clip Angle: Not less than 1-1/2 by 1-1/2 inches (38 by 38 mm), 0.068-inch- (1.72-mm-) thick, galvanized steel.
- F. Hat-Shaped, Rigid Furring Channels: ASTM C 645.
1. Minimum Base-Metal Thickness: 0.018 inch (0.45 mm).
 2. Depth: 7/8 inch (22.2 mm) unless otherwise indicated.
- G. Resilient Furring Channels: 1/2-inch- (13-mm-) deep, steel sheet members designed to reduce sound transmission.
1. Configuration: Asymmetrical.
- H. Cold-Rolled Furring Channels: 0.053-inch (1.34-mm) uncoated-steel thickness, with minimum 1/2-inch- (13-mm-) wide flanges.
1. Depth: 3/4 inch (19 mm) unless otherwise indicated.
 2. Furring Brackets: Adjustable, corrugated-edge type of steel sheet with minimum uncoated-steel thickness of 0.033 inch (0.8 mm).
 3. Tie Wire: ASTM A 641/A 641M, Class 1 zinc coating, soft temper, 0.062-inch- (1.59-mm-) diameter wire, or double strand of 0.048-inch- (1.21-mm-) diameter wire.

2.3 SUSPENSION SYSTEMS

- A. Tie Wire: ASTM A 641/A 641M, Class 1 zinc coating, soft temper, 0.062-inch- (1.59-mm-) diameter wire, or double strand of 0.048-inch- (1.21-mm-) diameter wire.
- B. Hanger Attachments to Concrete:
 - 1. Anchors: Fabricated from corrosion-resistant materials with holes or loops for attaching wire hangers and capable of sustaining, without failure, a load equal to 5 times that imposed by construction as determined by testing according to ASTM E 488 by an independent testing agency.
 - a. Type: Postinstalled, chemical anchor or postinstalled, expansion anchor.
 - 2. Powder-Actuated Fasteners: Suitable for application indicated, fabricated from corrosion-resistant materials with clips or other devices for attaching hangers of type indicated, and capable of sustaining, without failure, a load equal to 10 times that imposed by construction as determined by testing according to ASTM E 1190 by an independent testing agency.
- C. Wire Hangers: ASTM A 641/A 641M, Class 1 zinc coating, soft temper, 0.16 inch (4.12 mm) in diameter.
- D. Flat Hangers: Steel sheet, 1 by 3/16 inch (25 by 5 mm) by length indicated.
- E. Carrying Channels: Cold-rolled, commercial-steel sheet with a base-metal thickness of 0.053 inch (1.34 mm) and minimum 1/2-inch- (13-mm-) wide flanges.
 - 1. Depth: 1-1/2 inches (38 mm) unless otherwise indicated on Drawings.
- F. Furring Channels (Furring Members):
 - 1. Cold-Rolled Channels: 0.053-inch (1.34-mm) uncoated-steel thickness, with minimum 1/2-inch- (13-mm-) wide flanges, 3/4 inch (19 mm) deep.
 - 2. Steel Studs and Runners: ASTM C 645.
 - a. Minimum Base-Metal Thickness: 0.018 inch, 25 ga. (0.45 mm).
 - b. Depth: As indicated on Drawings.
 - 3. Hat-Shaped, Rigid Furring Channels: ASTM C 645, 7/8 inch (22 mm) deep.
 - a. Minimum Base-Metal Thickness: 0.018 inch (0.45 mm).
 - 4. Resilient Furring Channels: 1/2-inch- (13-mm-) deep members designed to reduce sound transmission.
 - a. Configuration: Asymmetrical or hat shaped.
- G. Grid Suspension System for Gypsum Board Ceilings: ASTM C 645, direct-hung system composed of main beams and cross-furring members that interlock.
 - 1. Products: Subject to compliance with requirements, available products that may be incorporated into the Work include, but are not limited to, the following:
 - a. Armstrong World Industries, Inc.; Drywall Grid Systems.

- b. Chicago Metallic Corporation; Drywall Grid System.
- c. USG Corporation; Drywall Suspension System.

2.4 AUXILIARY MATERIALS

- A. General: Provide auxiliary materials that comply with referenced installation standards.
 - 1. Fasteners for Metal Framing: Of type, material, size, corrosion resistance, holding power, and other properties required to fasten steel members to substrates.
- B. Isolation Strip at Exterior Walls: Provide one of the following:
 - 1. Asphalt-Saturated Organic Felt: ASTM D 226, Type I (No. 15 asphalt felt), nonperforated.
 - 2. Foam Gasket: Adhesive-backed, closed-cell vinyl foam strips that allow fastener penetration without foam displacement, 1/8 inch (3.2 mm) thick, in width to suit steel stud size.
- C. Pre-compressed Spring Hangers for Sound Isolation: Ceiling Hangers shall be fail safe and include a steel frame containing an AASHTO Bridge Bearing Quality LDS Rubber Element at the top and a nominal 1" deflection steel spring at the bottom. Springs shall be seated in an LDS cup with a rubber bushing extending through the box to prevent metal to metal contact between the steel suspension rod and the frame. Dynamic Stiffness of Cup and Element shall not exceed 1.4. The ID of the bushing must allow a 30° swing from side to side before rod contact. Springs shall be factory precompressed to 70% of the assigned deflection.
 - 1. Basis of Design product: Mason Industries 30NCC for 1-1/2 x 1/2 channel,.
 - 2. Submittals shall confirm AASHTO Quality and Dynamic Stiffness in addition to deflection.

PART 3 - EXECUTION

3.1 EXAMINATION

- A. Examine areas and substrates, with Installer present, and including welded hollow-metal frames, cast-in anchors, and structural framing, for compliance with requirements and other conditions affecting performance of the Work.
- B. Proceed with installation only after unsatisfactory conditions have been corrected.

3.2 PREPARATION

- A. Suspended Assemblies: Coordinate installation of suspension systems with installation of overhead structure to ensure that inserts and other provisions for anchorages to building structure have been installed to receive hangers at spacing required to support the Work and that hangers will develop their full strength.

1. Furnish concrete inserts and other devices indicated to other trades for installation in advance of time needed for coordination and construction.

B. Coordination with Sprayed Fire-Resistive Materials:

1. Before sprayed fire-resistive materials are applied, attach offset anchor plates or ceiling runners (tracks) to surfaces indicated to receive sprayed fire-resistive materials. Where offset anchor plates are required, provide continuous plates fastened to building structure not more than 24 inches (610 mm) o.c.
2. After sprayed fire-resistive materials are applied, remove them only to extent necessary for installation of non-load-bearing steel framing. Do not reduce thickness of fire-resistive materials below that required for fire-resistance ratings indicated. Protect adjacent fire-resistive materials from damage.

3.3 INSTALLATION, GENERAL

- A. Installation Standard: ASTM C 754, except comply with framing sizes and spacing indicated.
1. Gypsum Board Assemblies: Also comply with requirements in ASTM C 840 that apply to framing installation.
- B. Install supplementary framing, and blocking to support fixtures, equipment services, heavy trim, grab bars, toilet accessories, furnishings, or similar construction.
- C. Install bracing at terminations in assemblies.
- D. Do not bridge building control and expansion joints with non-load-bearing steel framing members. Frame both sides of joints independently.
- E. Cutting, Notching and Boring Holes in Nonstructural Steel Wall Framing:
1. Flanges and lips of nonstructural steel wall studs shall not be cut or notched.
 2. Holes in webs of nonstructural steel wall studs shall be permitted along the centerline of the web of the framing member, shall not exceed 1-1/2 inches (38 mm) in width or 4 inches (102 mm) in length, and the holes shall not be spaced less than 24 inches (610 mm) center to center from another hole or less than 10 inches (254 mm) from the bearing end.

3.4 INSTALLING FRAMED ASSEMBLIES

- A. Where studs are installed directly against exterior masonry walls or dissimilar metals at exterior walls, install isolation strip between studs and exterior wall.
- B. Install studs so flanges within framing system point in same direction.
1. Space studs at 16 inches (406 mm) o.c. unless otherwise indicated.
- C. Install tracks (runners) at floors and overhead supports. Extend framing full height to structural supports or substrates above suspended ceilings, except where partitions

are indicated to terminate at suspended ceilings. Continue framing around ducts penetrating partitions above ceiling.

1. Slip-Type Head Joints: Where framing extends to overhead structural supports, install to produce joints at tops of framing systems that prevent axial loading of finished assemblies.
 2. Door Openings: Screw vertical studs at jambs to jamb anchor clips on door frames; install runner track section (for cripple studs) at head and secure to jamb studs.
 - a. Install two studs at each jamb unless otherwise indicated.
 - b. Install cripple studs at head adjacent to each jamb stud, with a minimum 1/2-inch (13-mm) clearance from jamb stud to allow for installation of control joint in finished assembly.
 - c. Extend jamb studs through suspended ceilings and attach to underside of overhead structure.
 3. Other Framed Openings: Frame openings other than door openings the same as required for door openings unless otherwise indicated. Install framing below sills of openings to match framing required above door heads.
 4. Fire-Resistance-Rated Partitions: Install framing to comply with fire-resistance-rated assembly indicated and support closures and to make partitions continuous from floor to underside of solid structure.
 5. Sound-Rated Partitions: Install framing to comply with sound-rated assembly indicated.
 - a. Sound Isolation pads shall be installed as a continuous resilient layer separating the base and/or top plate of the stud wall assembly from the non-isolated floor and/or ceiling deck where shown on drawings. Wallboard shall be cut and installed to allow a 1/4" to 3/8" gap at the isolation joint for the installation of resilient non-hardening acoustical caulking.
 6. Curved Partitions:
 - a. Bend track to uniform curve and locate straight lengths so they are tangent to arcs.
 - b. Begin and end each arc with a stud, and space intermediate studs equally along arcs. On straight lengths of no fewer than two studs at ends of arcs, place studs 6 inches (150 mm) o.c.
- D. Install steel studs used as furring with clip angles at midpoint of wall span. Install additional clips to limit deflection to L/240 for walls finished with gypsum wall board and L/360 for walls finished with tile or plaster when subject to 5 psf (239 Pa) lateral load.
- E. Direct Furring: Attach to concrete or masonry with stub nails, screws designed for masonry attachment, or powder-driven fasteners spaced 24 inches (610 mm) o.c.
- F. Installation Tolerance: Install each framing member so fastening surfaces vary not more than 1/8 inch (3 mm) from the plane formed by faces of adjacent framing.

3.5 INSTALLING SUSPENSION SYSTEMS

- A. Install suspension system components in sizes and spacings indicated on Drawings, but not less than those required by referenced installation standards for assembly types and other assembly components indicated.
- B. Isolate suspension systems from building structure where they abut or are penetrated by building structure to prevent transfer of loading imposed by structural movement.
- C. Isolate suspension systems from building structure to provide sound dampening using spring hangers where indicated on Drawings.
- D. Suspend hangers from building structure as follows:
 - 1. Install hangers plumb and free from contact with insulation or other objects within ceiling plenum that are not part of supporting structural or suspension system.
 - a. Splay hangers only where required to miss obstructions and offset resulting horizontal forces by bracing, countersplaying, or other equally effective means.
 - 2. Where width of ducts and other construction within ceiling plenum produces hanger spacings that interfere with locations of hangers required to support standard suspension system members, install supplemental suspension members and hangers in the form of trapezes or equivalent devices.
 - a. Size supplemental suspension members and hangers to support ceiling loads within performance limits established by referenced installation standards.
 - 3. Wire Hangers: Secure by looping and wire tying, either directly to structures or to inserts, eye screws, or other devices and fasteners that are secure and appropriate for substrate, and in a manner that will not cause hangers to deteriorate or otherwise fail.
 - 4. Flat Hangers: Secure to structure, including intermediate framing members, by attaching to inserts, eye screws, or other devices and fasteners that are secure and appropriate for structure and hanger, and in a manner that will not cause hangers to deteriorate or otherwise fail.
 - 5. Do not attach hangers to steel roof deck.
 - 6. Do not attach hangers to permanent metal forms. Furnish cast-in-place hanger inserts that extend through forms.
 - 7. Do not attach hangers to rolled-in hanger tabs of composite steel floor deck.
 - 8. Do not connect or suspend steel framing from ducts, pipes, or conduit.
- E. Fire-Resistance-Rated Assemblies: Wire tie furring channels to supports.
- F. Grid Suspension Systems: Attach perimeter wall track or angle where grid suspension systems meet vertical surfaces. Mechanically join main beam and cross-furring members to each other and butt-cut to fit into wall track.

- G. Installation Tolerances: Install suspension systems that are level to within 1/8 inch in 12 feet (3 mm in 3.6 m) measured lengthwise on each member that will receive finishes and transversely between parallel members that will receive finishes.

END OF SECTION 092216

SECTION 092800 - GLASS-REINFORCED GYPSUM FABRICATIONS

PART 1 - GENERAL

1.1 SUMMARY

- A. This Section includes the following preformed products for interior use, fabricated in glass-reinforced gypsum:
 - 1. Column covers.
- B. Related Work include the following:
 - 1. Framing and furring for items requiring anchorage are specified in Division 05 Section "Metal Fabrications."
 - 2. Blocking, nailers, and shims for items requiring anchorage are specified in Division 06 Section "Miscellaneous Carpentry."
 - 3. Finishing of column covers is specified in Division 09 Section "Ceramic Tile."

1.2 SYSTEM PERFORMANCE REQUIREMENTS

- A. Fabricate and install glass-reinforced gypsum units to withstand, without failure or cracking, loads from gravity and structural movement, including thermally induced movement, and to resist other conditions of in-service use that the building will experience.

1.3 ACTION SUBMITTALS

- A. Product data for each type of product specified.
- B. Shop drawings showing thickness, finish, ornamentation, tolerances, and anchorage details. Indicate attachment methods, imbedded supports, reinforcement, fabrication, joint treatments, and supports.
- C. Samples for verifying glass-reinforced gypsum units. Show the full range of variations in detail expected.
 - 1. Glass-Reinforced Gypsum Units: 2-foot- (0.50-m-) long section with finished joint, typical of the units specified.

1.4 INFORMATIONAL SUBMITTALS

- A. Installer certificates signed by manufacturer certifying that Installers comply with requirements under "Quality Assurance" Article.

- B. Qualification data for firms and persons specified in "Quality Assurance" Article to demonstrate their capabilities and experience. Include lists of completed projects with project names and addresses, names and addresses of architects and owners, and other information specified.

1.5 QUALITY ASSURANCE

- A. Installer Qualifications: Engage an experienced Installer who has completed glass-reinforced gypsum installations similar in material, design, and extent to that indicated for this Project and with a construction record of successful in-service performance.
- B. Manufacturer Qualifications: Manufacturer must be able to show that he has at least 5 years experience in this type of work, has experienced personnel, physical facilities, established quality control procedures and management capacity sufficient to produce the required parts without causing delay of the project.
- C. Single Source Responsibility for Glass-Reinforced Gypsum Materials: Obtain glass-reinforced gypsum fabrications from a single manufacturer.
- D. Fire-Test-Response Characteristics: Provide glass-reinforced gypsum units with the following surface-burning characteristics as determined by testing identical products per ASTM E 84 by UL or another testing and inspecting agency acceptable to authorities having jurisdiction.
 - 1. Flame Spread: 25 or less.
 - 2. Smoke Developed: 450 or less.
- E. Mockups: Prior to installing glass-reinforced gypsum units, construct mockups for each form of construction and finish required to verify selections made under sample submittals and to demonstrate aesthetic effects as well as qualities of materials and execution. Build mockups to comply with the following requirements, using materials indicated for final unit of Work.
 - 1. Locate mockups on site in the location and of the size indicated or, if not indicated, as directed by Architect.
 - 2. Demonstrate the proposed range of aesthetic effects and workmanship.
 - 3. Apply specified tile finish to column covers.
 - 4. Retain and maintain mockups during construction in an undisturbed condition as a standard for judging the completed Work.
 - 5. Accepted mockups in an undisturbed condition at the time of Substantial Completion may become part of the completed Work.
- F. Engineering Responsibility: Engineer glass-reinforced gypsum units by qualified professional engineer legally authorized to practice in the jurisdiction where Project is located.

1.6 DELIVERY, STORAGE, AND HANDLING

- A. Deliver glass-reinforced gypsum units in factory-wrapped crates, packaged to keep units dry and free of moisture.
- B. Store glass-reinforced gypsum units at Project site to prevent cracking, distortion, warping, staining, or other physical damage.
- C. Comply with manufacturer's recommendations for storing and handling units.

1.7 PROJECT CONDITIONS

- A. Field Measurements: Verify dimensions by field measurements before fabricating glass-reinforced gypsum units and show recorded measurements on shop drawings. Coordinate fabrication schedule with construction progress to avoid delaying the Work.
- B. Space Enclosure and Environmental Limitations: Do not install glass-reinforced gypsum units until space is enclosed and weatherproof, and ambient temperature and humidity conditions are and will be continuously maintained at values near those indicated for final occupancy.
 - 1. Acclimatize glass-reinforced gypsum units by removing packaging and storing in the installation space not less than 48 hours before installation.

PART 2 - PRODUCTS

2.1 MANUFACTURERS

- A. Manufacturers: Subject to compliance with requirements, provide products by Castle Access Panels and Forms Inc. or equal products of one of the following:
 - 1. Decoform Corporation
 - 2. Casting Designs, Inc.
 - 3. GRG Technologies
 - 4. Plastrglas.

2.2 MATERIALS

- A. Gypsum Material: Provide alpha-based, calcined gypsum produced from materials complying with ASTM C 22.
- B. Glass Fibers: Comply with ASTM D 578 "E" glass type chopped into 1 inch lengths.
- C. Glass-Reinforced Gypsum Units: Glass fiber shall be 5 to 6 percent by weight of gypsum and glass mixture. Provide units identical to those tested for the following performance characteristics, per test method indicated below, by testing and inspecting organizations acceptable to authorities having jurisdiction.
 - 1. Hardness: 95 RH min Rockwell Scale.

2. Modulus of Rupture 3200 - 3500 psi when tested in accordance with ASTM C 109.
3. Modulus of Elasticity: 2.7 - 3.8 x 10⁶ psi when tested in accordance with ASTM C 109.
4. Coefficient of Linear Thermal Expansion: 8 x 10⁻⁶ inch/inch/deg F when tested in accordance with ASTM D 696.

- D. Material Compatibility: Provide GFRG products with surface characteristics prepared for mortar attachment of ceramic tile.

2.3 MISCELLANEOUS MATERIALS

- A. Embedded or Inserted Hardware: Complying with ASTM A 641, and integrated into the members without visibility on the finish face.
- B. Fasteners: Self-tapping gypsum wallboard screws.
- C. Adhesives: As recommended in manufacturer's printed instructions, and meeting VOC requirements of jurisdiction.
- D. Sealants: Refer to Section 079200 for sealant materials.

2.4 FABRICATION

- A. Basis of Design Product: GFRG Column Covers by Castle Access Panels & Forms, Inc. or equal.
1. Shape: Round
 2. Diameter: 30" and 28" (capital)
 3. Column Base: Mounted on concrete base.
 4. Column Top: Recessed capital, as indicated on Drawings.
 5. Shaft: Straight
 6. Shell Thickness: Minimum 1/4", and minimum 1/2" at edges.
 7. Appearance: Seamless.
- B. Fabricate units as large as possible to minimize joints.
- C. Fabricate units with smooth finished surfaces, prepared to accept application of ceramic tile finish. Repair hollows, voids, scratches, and finish surface imperfections.
- D. Dimensional Tolerances of Units: As follows:
1. Warpage or Bowing: Plus or minus 1/16 inch.
 2. Dimensional, all Directions: Plus or minus 1/8 inch.
 3. Plane Surface Straightness: Plus or minus 1/8 inch.
 4. Overall Assembled Length and Width: Plus or minus 1/8 inch per 10 feet.
 5. Out of Round: Plus or minus 1/16 inch.
 6. .

- E. Construct molds for column cover units of materials resulting in smooth, finished products conforming to profiles and dimensions indicated.
- F. Combine glass fiber and matrix slurry at rates to achieve desired mix proportions and glass content, and sprayed in accordance with manufacturer's instructions.
- G. Embed indicated or required inserts in matrix to develop full strengths. Embed items after required minimum body thickness have been achieved.
- H. Form columns to dimensions indicated. Tolerance as specified. Curved panels accurately formed to radii. Fabricate column covers in two sections with vertical butt joint, suitable for field finishing.
- I. Carefully remove units from molds and repair hollows, voids, scratches and other surface imperfections. Surface shall be primer ready.
- J. Factory fabricate accessories and trim components, hardware, including attachment devices, ready for installation.
- K. Provide base and ceiling joints as indicated, or if not indicated, as per manufacturer's standard detail.

2.5 FINISH

- A. Column cover panels shall be free of scratches and blemishes; column covers to be field finished as specified in Division 09 Sections.

PART 3 - EXECUTION

3.1 EXAMINATION

- A. Examine substrates areas and conditions with Installer present for compliance with requirements for maximum moisture content, installation tolerances, and other conditions affecting performance of glass-reinforced gypsum units. Do not proceed until unsatisfactory conditions have been corrected.

3.2 INSTALLATION

- A. Install glass-reinforced gypsum units plumb, level, true, and aligned with adjacent materials. Use concealed shims where required for alignment.
- B. Erection Tolerances: As follows:
 - 1. Plane Alignment (Panel to Panel): 1/16 inch (1.6 mm).
 - 2. Variation from Plumb: Plus or minus 1/8 inch (3.2 mm) per 10 feet (3 m).
 - 3. Variation from Straightness: Plus or minus 1/4 inch (6.3 mm) per 25 feet (7.6 m).
 - 4. Assembly Deflection: Not greater than the length of the assembly divided by 240.

5. Joint Alignment: Not more than 1/8 inch (3.2 mm).
 6. Joint Width: Not more than 3/8 inch (9.5 mm).
- C. Predrill fastener holes in ornamentation. Clean fastener holes, removing dirt and oil.
 - D. Screw fasteners in place by hand. Do not use pneumatic staple guns. Countersink flathead screws.
 - E. Fasteners as required to comply with dimensional tolerances and not less than 5/16 inch (7.9 mm) from edge and end.
 - F. Patch fastener holes with bedding compound and fiberglass tape applied flush with finish face. Sand patch smooth and level.
 - G. Attach pieces at joints with adhesive, and band or brace together until adhesive is cured. Cure adhesive according to manufacturer's printed instructions.
 - H. Joint Finishing: Comply with ASTM C 840. Provide smooth and contiguous surface.

END OF SECTION 092800

SECTION 092900 - GYPSUM BOARD

PART 1 - GENERAL

1.1 SUMMARY

A. Section Includes:

1. Interior gypsum board.
2. Cement board.
3. Sound-attenuation blankets

B. Related Requirements:

1. Section 092216 "Non-Structural Metal Framing" for non-structural framing and suspension systems that support gypsum board panels.
2. Section 092116.23 "Gypsum Board Shaft Wall Assemblies" for metal shaft-wall framing, gypsum shaft liners, and other components of shaft-wall assemblies.

1.2 ACTION SUBMITTALS

A. Product Data: For each type of product.

B. Samples: For the following products:

1. Trim Accessories: Full-size Sample in 12-inch- (300-mm-) long length for each trim accessory indicated.

1.3 QUALITY ASSURANCE

A. Mockups: Before beginning gypsum board installation, install mockups of at least 100 sq. ft. (9 sq. m) in surface area to demonstrate aesthetic effects and set quality standards for materials and execution.

1. Install mockups for the following:
 - a. Each level of gypsum board finish indicated for use in exposed locations.
2. Apply or install final decoration indicated, including painting and wallcoverings, on exposed surfaces for review of mockups.
3. Simulate finished lighting conditions for review of mockups.
4. Subject to compliance with requirements, approved mockups may become part of the completed Work if undisturbed at time of Substantial Completion.

1.4 DELIVERY, STORAGE AND HANDLING

A. Store materials inside under cover and keep them dry and protected against weather, condensation, direct sunlight, construction traffic, and other potential causes of damage. Stack panels flat and supported on risers on a flat platform to prevent sagging.

1.5 FIELD CONDITIONS

- A. Environmental Limitations: Comply with ASTM C 840 requirements or gypsum board manufacturer's written recommendations, whichever are more stringent.
- B. Do not install paper-faced gypsum panels until installation areas are enclosed and conditioned.
- C. Do not install panels that are wet, those that are moisture damaged, and those that are mold damaged.
 - 1. Indications that panels are wet or moisture damaged include, but are not limited to, discoloration, sagging, or irregular shape.
 - 2. Indications that panels are mold damaged include, but are not limited to, fuzzy or splotchy surface contamination and discoloration.

PART 2 - PRODUCTS

2.1 PERFORMANCE REQUIREMENTS

- A. Fire-Resistance-Rated Assemblies: For fire-resistance-rated assemblies, provide materials and construction identical to those tested in assembly indicated according to ASTM E 119 by an independent testing agency.
- B. STC-Rated Assemblies: For STC-rated assemblies, provide materials and construction identical to those tested in assembly indicated according to ASTM E 90 and classified according to ASTM E 413 by an independent testing agency.

2.2 GYPSUM BOARD, GENERAL

- A. Size: Provide maximum lengths and widths available that will minimize joints in each area and that correspond with support system indicated.

2.3 INTERIOR GYPSUM BOARD

- A. Manufacturers: Subject to compliance with requirements, provide products by one of the following:
 - 1. CertainTeed Corp.
 - 2. Georgia-Pacific Gypsum LLC.
 - 3. Lafarge North America Inc.
 - 4. National Gypsum Company.
 - 5. USG Corporation.
- B. Gypsum Wallboard: ASTM C 1396/C 1396M.
 - 1. Thickness: 1/2 inch (12.7 mm).
 - 2. Where drawings indicate regular type 5/8 inch (15.9 mm), provide 5/8 inch (15.9 mm) Type X indicated below.
 - 3. Long Edges: Tapered.
- C. Gypsum Board, Type X: ASTM C 1396/C 1396M.

1. Thickness: 5/8 inch (15.9 mm).
2. Long Edges: Tapered.

D. Moisture- and Mold-Resistant Gypsum Board: ASTM C 1396/C 1396M. With moisture- and mold-resistant core and paper surfaces, in 5/8 inch thickness unless otherwise indicated, with tapered edges; panels shall be classified as Type X

1. Mold Resistance: ASTM D 3273, score of 10 as rated according to ASTM D 3274.
2. Products: Subject to compliance with requirements, provide one of the following or equal:
 - a. National Gypsum Company; Type XP/PR
 - b. United States Gypsum Co.; Mold Tough

E. Abuse-Resistant Gypsum Board: ASTM C 1629/C 1629M.

1. Core: 5/8 inch (15.9 mm), Type X.
2. Long Edges: Tapered.
3. Mold Resistance: ASTM D 3273, score of 10 as rated according to ASTM D 3274.
4. Performance Data:
 - a. Surface Abrasion: ASTM C1629. Classification Level 2
 - b. Surface Indentation: ASTM C1629. Classification Level 1
 - c. Soft-body Impact Test: ASTM C1629. Classification Level 1
5. Products: Subject to compliance with requirements, provide one of the following or equal:
 - a. Protecta AR 100 Type X with Mold Defense; Lafarge North America Inc.
 - b. ProRoc Gypsum Board Panels; CertainTeed, Division of BPB.

F. Flexible Gypsum Board: ASTM C 1396/C 1396M. Manufactured to bend to fit radii and to be more flexible than standard regular-type gypsum board of same thickness.

1. Thickness: 1/4 inch (6.4 mm).
 - a. Long Edges: Tapered

2.4 SPECIALTY GYPSUM BOARD

A. Gypsum Board, Type C: ASTM C 1396/C 1396M. Manufactured to have increased fire-resistive capability.

1. Products: Subject to compliance with requirements, provide one of the following or equal:
 - a. CertainTeed Corp.; ProRoc Type C.
 - b. Lafarge North America Inc.; Firecheck Type C.
 - c. National Gypsum Company; Gold Bond Fire-Shield C.
 - d. USG Corporation; Firecode C Core.
2. Thickness: 5/8 inch (15.9 mm), unless otherwise indicated.
3. Long Edges: Tapered.
4. Provide where required by UL Design or NER 258.

B. Acoustic (Sound Dampening) Gypsum Board: Multi-layer gypsum panel engineered to provide maximum sound attenuation across a broad frequency range, meeting ASTM C1396, Federal Specification SS-L-30D Type III & Grade X.

1. Thickness: 1-3/8 inch.
2. Edges: Tapered
3. Core: Type X Core, UL Core Type QR545
4. Faces: 100% recycled paper on front, back and long edges
5. STC-rated Assemblies (per ASTM E90): 60-80
6. Flame Spread (per ASTM E84): Class A
7. Basis of Design product: QuietRock 545 by PABCO Gypsum, or equal.

2.5 TILE BACKING PANELS

- A. Cementitious Backer Units: ANSI A118.9 and ASTM C 1288 or 1325, with manufacturer's standard edges.
1. Products: Subject to compliance with requirements, provide one of the following:
 - a. CertainTeed Corp.; FiberCement BackerBoard.
 - b. Custom Building Products; Wonderboard.
 - c. James Hardie Building Products, Inc.; Hardiebacker 500.
 - d. National Gypsum Company, Permabase Cement Board.
 - e. USG Corporation; DUROCK Cement Board.
 2. Thickness: 1/2 inch (12.7 mm) or 5/8 inch (15.9 mm) as indicated.
 3. Mold Resistance: ASTM D 3273, score of 10 as rated according to ASTM D 3274.

2.6 TRIM ACCESSORIES

- A. Interior Trim: ASTM C 1047.
1. Material: Galvanized-coated steel sheet or rolled zinc
 2. Shapes:
 - a. Cornerbead.
 - b. Bullnose bead.
 - c. LC-Bead: J-shaped; exposed long flange receives joint compound.
 - d. L-Bead: L-shaped; exposed long flange receives joint compound.
 - e. Expansion (control) joint.
 - f. Curved-Edge Cornerbead: With notched or flexible flanges.
- B. Aluminum Trim: Extruded accessories of profiles and dimensions indicated.
1. Manufacturers: Subject to compliance with requirements, provide products by one of the following:
 - a. Fry Reglet Corp.
 - b. Gordon, Inc.
 - c. Pittcon Industries.
 2. Aluminum: Alloy and temper with not less than the strength and durability properties of ASTM B 221 (ASTM B 221M), Alloy 6063-T5.
 3. Finish:
 - a. Curved Drywall Trim: Corrosion-resistant primer compatible with joint compound and finish materials specified.
 - b. Extruded Aluminum Partition Closures: Clear anodized aluminum.
 4. Basis of Design Products:
 - a. Curved Drywall Trim: Provide Contura curved drywall trim by Gordon Inc. for locations indicated on the Drawings, in sizes required.

2.7 JOINT TREATMENT MATERIALS

- A. General: Comply with ASTM C 475/C 475M.
- B. Joint Tape:
 - 1. Interior Gypsum Board: Paper.
 - 2. Tile Backing Panels: As recommended by panel manufacturer.
- C. Joint Compound for Interior Gypsum Board: For each coat use formulation that is compatible with other compounds applied on previous or for successive coats.
 - 1. Prefilling: At open joints, beveled panel edges, and damaged surface areas, use setting-type taping compound.
 - 2. Embedding and First Coat: For embedding tape and first coat on joints, fasteners, and trim flanges, use factory mixed drying-type, all-purpose compound.
 - a. Use setting-type compound for installing paper-faced metal trim accessories.
 - 3. Fill Coat: For second coat, use factory mixed drying-type, all-purpose compound.
 - 4. Finish Coat: For third coat, use setting-type, sandable topping compound.
 - 5. Skim Coat: For final coat of Level 5 finish, use setting-type, sandable topping compound.
- D. Joint Compound for Tile Backing Panels:
 - 1. Cementitious Backer Units: As recommended by backer unit manufacturer.

2.8 AUXILIARY MATERIALS

- A. General: Provide auxiliary materials that comply with referenced installation standards and manufacturer's written recommendations.
- B. Steel Drill Screws: ASTM C 1002, unless otherwise indicated.
 - 1. Use screws complying with ASTM C 954 for fastening panels to steel members from 0.033 to 0.112 inch (0.84 to 2.84 mm) thick.
 - 2. For fastening cementitious backer units, use screws of type and size recommended by panel manufacturer.
- C. Laminating Adhesive: Adhesive or joint compound recommended for directly adhering gypsum panels to continuous substrate.
 - 1. Laminating adhesive shall have a VOC content of 50 g/L or less when calculated according to 40 CFR 59, Subpart D (EPA Method 24).
- D. Sound Attenuation Blankets: ASTM C 665, Type I (blankets without membrane facing) produced by combining thermosetting resins with mineral fibers manufactured from glass, slag wool, or rock wool.
 - 1. Fire-Resistance-Rated Assemblies: Provide mineral-fiber SAFB where required by the UL assembly.
- E. Acoustical Joint Sealant: As specified in Section 079200 "Joint Sealants"

- F. Sealant for Acoustical (Sound Dampening) Gypsum Board: QuietSeal Pro by PABCO Gypsum, or equal.
- G. Wrap for Electrical Devices in Acoustical (Sound Dampening) Gypsum Board Construction: QuietPutty by PABCO Gypsum, or equal.

PART 3 - EXECUTION

3.1 EXAMINATION

- A. Examine areas and substrates including welded hollow-metal frames and framing, with Installer present, for compliance with requirements and other conditions affecting performance.
- B. Examine panels before installation. Reject panels that are wet, moisture damaged, and mold damaged.
- C. Proceed with installation only after unsatisfactory conditions have been corrected.

3.2 APPLYING AND FINISHING PANELS, GENERAL

- A. Comply with ASTM C 840.
- B. Install ceiling panels across framing to minimize the number of abutting end joints and to avoid abutting end joints in central area of each ceiling. Stagger abutting end joints of adjacent panels not less than one framing member.
- C. Install panels with face side out. Butt panels together for a light contact at edges and ends with not more than 1/16 inch (1.5 mm) of open space between panels. Do not force into place.
- D. Locate edge and end joints over supports, except in ceiling applications where intermediate supports or gypsum board back-blocking is provided behind end joints. Do not place tapered edges against cut edges or ends. Stagger vertical joints on opposite sides of partitions. Do not make joints other than control joints at corners of framed openings.
- E. Form control and expansion joints with space between edges of adjoining gypsum panels.
- F. Cover both faces of support framing with gypsum panels in concealed spaces (above ceilings, etc.), except in chases braced internally.
 - 1. Unless concealed application is indicated or required for sound, fire, air, or smoke ratings, coverage may be accomplished with scraps of not less than 8 sq. ft. (0.7 sq. m) in area.
 - 2. Fit gypsum panels around ducts, pipes, and conduits.
 - 3. Where partitions intersect structural members projecting below underside of floor/roof slabs and decks, cut gypsum panels to fit profile formed by structural members; allow 1/4- to 3/8-inch- (6.4- to 9.5-mm-) wide joints to install sealant.

- G. Isolate perimeter of gypsum board applied to non-load-bearing partitions at structural abutments, except floors. Provide 1/4- to 1/2-inch- (6.4- to 12.7-mm-) wide spaces at these locations and trim edges with edge trim where edges of panels are exposed. Seal joints between edges and abutting structural surfaces with acoustical sealant.
- H. Attachment to Steel Framing: Attach panels so leading edge or end of each panel is attached to open (unsupported) edges of stud flanges first.
- I. STC-Rated Assemblies: Seal construction at perimeters, behind control joints, and at openings and penetrations with a continuous bead of acoustical sealant. Install acoustical sealant at both faces of partitions at perimeters and through penetrations. Comply with ASTM C 919 and with manufacturer's written recommendations for locating edge trim and closing off sound-flanking paths around or through assemblies, including sealing partitions above acoustical ceilings.
 - 1. Refer to Section 079200 for additional requirements.
 - 2. For assemblies containing acoustical (sound dampening) gypsum board, comply with manufacturer's directions for complete sound sealed installation. Seal room perimeter with recommended sealant and wrap electrical units with putty as per manufacturer's directions.
- J. Install sound attenuation blankets before installing gypsum panels unless blankets are readily installed after panels have been installed on one side.

3.3 APPLYING INTERIOR GYPSUM BOARD

- A. Install interior gypsum board in the following locations:
 - 1. Type X: Vertical surfaces unless otherwise indicated.
 - 2. Ceiling Type: Ceiling surfaces.
 - 3. Abuse-Resistant Type: As indicated on Drawings.
 - 4. Moisture- and Mold-Resistant Type: As indicated on Drawings.
 - 5. Type C: Where required for specific fire-resistance-rated assembly indicated.
 - 6. Acoustical (Sound Dampening) Type: As indicated on Drawings.
 - 7. Flexible Type: Apply in double layer at curved assemblies.
- B. Single-Layer Application:
 - 1. On ceilings, apply gypsum panels before wall/partition board application to greatest extent possible and at right angles to framing unless otherwise indicated.
 - 2. On partitions/walls, apply gypsum panels vertically (parallel to framing) unless otherwise indicated or required by fire-resistance-rated assembly, and minimize end joints.
 - a. Stagger abutting end joints not less than one framing member in alternate courses of panels.
 - b. At stairwells and other high walls, install panels horizontally unless otherwise indicated or required by fire-resistance-rated assembly.
 - 3. Fastening Methods: Apply gypsum panels to supports with steel drill screws.
- C. Multilayer Application:
 - 1. On ceilings, apply gypsum board indicated for base layers before applying base layers on walls/partitions; apply face layers in same sequence. Apply base

layers at right angles to framing members and offset face-layer joints one framing member, 16 inches (400 mm) minimum, from parallel base-layer joints, unless otherwise indicated or required by fire-resistance-rated assembly.

2. On partitions/walls, apply gypsum board indicated for base layers and face layers vertically (parallel to framing) with joints of base layers located over stud or furring member and face-layer joints offset at least one stud or furring member with base-layer joints, unless otherwise indicated or required by fire-resistance-rated assembly. Stagger joints on opposite sides of partitions.
3. Fastening Methods: Fasten base layers and face layers separately to supports with screws.

A. Laminating to Substrate: Where gypsum panels are indicated as directly adhered to a substrate (other than studs, joists, furring members, or base layer of gypsum board), comply with gypsum board manufacturer's written recommendations and temporarily brace or fasten gypsum panels until fastening adhesive has set.

B. Curved Surfaces:

1. Install panels horizontally (perpendicular to supports) and unbroken, to extent possible, across curved surface plus 12-inch- (300-mm-) long straight sections at ends of curves and tangent to them.
2. For double-layer construction, fasten base layer to studs with screws 16 inches (400 mm) o.c. Center gypsum board face layer over joints in base layer, and fasten to studs with screws spaced 12 inches (300 mm) o.c

3.4 APPLYING TILE BACKING PANELS

- A. Cementitious Backer Units: ANSI A108.11, at showers, tubs, and where indicated.
- B. Where tile backing panels abut other types of panels in same plane, shim surfaces to produce a uniform plane across panel surfaces.

3.5 INSTALLING TRIM ACCESSORIES

A. General: For trim with back flanges intended for fasteners, attach to framing with same fasteners used for panels. Otherwise, attach trim according to manufacturer's written instructions.

B. Control Joints: Install control joints according to ASTM C 840 and in specific locations approved by Architect for visual effect.

1. Install control joints on 30 foot maximum centers, for all partitions, at locations indicated, and as detailed. Align control joints with door frames wherever possible, with space between edges of adjoining gypsum panels, as well as supporting framing behind gypsum panels.
2. Install control joints at 50 foot maximum centers, with areas not to exceed 2,500 sq. ft. for all ceiling areas, at locations indicated, and as detailed.

C. Interior Trim: Install in the following locations:

1. Cornerbead: Use at outside corners unless otherwise indicated.
2. Bullnose Bead: Use where indicated.
3. LC-Bead: Use at exposed panel edges.

4. L-Bead: Use where indicated.
5. Curved-Edge Cornerbead: Use at curved openings.

D. Aluminum Trim: Install in locations indicated on Drawings.

3.6 FINISHING GYPSUM BOARD

- A. General: Treat gypsum board joints, interior angles, edge trim, control joints, penetrations, fastener heads, surface defects, and elsewhere as required to prepare gypsum board surfaces for decoration. Promptly remove residual joint compound from adjacent surfaces.
- B. Prefill open joints, rounded or beveled edges, and damaged surface areas.
- C. Apply joint tape over gypsum board joints, except for trim products specifically indicated as not intended to receive tape.
- D. Gypsum Board Finish Levels: Finish panels to levels indicated below and according to ASTM C 840:
 1. Level 1: Ceiling plenum areas, concealed areas, and where indicated.
 2. Level 2: Panels that are substrate for tile.
 3. Level 4: At all panel surfaces that will be exposed to view unless otherwise indicated.
 4. Level 5: Provide Level 5 finish at all areas where wall washed lighting is indicated and at surfaces scheduled to receive gloss paint, and elsewhere specifically indicated on Drawings and schedules.
- E. Cementitious Backer Units: Finish according to manufacturer's written instructions.

3.7 IDENTIFICATION

- A. Fire walls, fire barriers, fire partitions, smoke barriers and smoke partitions or any other wall required to have protected openings or penetrations shall be effectively and permanently identified with signs or stenciling. Such identification shall:
 1. Be located in accessible concealed floor, floor-ceiling or attic spaces.
 2. Be repeated at intervals not exceeding 30 feet (914 mm) measured horizontally along the wall or partition.
 3. Include lettering not less than 0.5 inch (12.7 mm)) in height, incorporating the followings wording: "FIRE AND/OR SMOKE BARRIER—PROTECT ALL OPENINGS," or other wording to reflect the wall type as indicated on the Code Summary Drawings.

3.8 PROTECTION

- A. Protect adjacent surfaces from drywall compound and promptly remove from floors and other non-drywall surfaces. Repair surfaces stained, marred, or otherwise damaged during drywall application.
- B. Protect installed products from damage from weather, condensation, direct sunlight, construction, and other causes during remainder of the construction period.

- C. Remove and replace panels that are wet, moisture damaged, and mold damaged.
 - 1. Indications that panels are wet or moisture damaged include, but are not limited to, discoloration, sagging, or irregular shape.
 - 2. Indications that panels are mold damaged include, but are not limited to, fuzzy or splotchy surface contamination and discoloration.

END OF SECTION 092900

SECTION 093100 - CERAMIC TILING

PART 1 - GENERAL

1.1 SUMMARY

A. This Section includes the following:

1. Porcelain tile
2. Ceramic tile
3. Quarry tile
4. Trim and edge accessories.
5. Waterproof membrane for tile installations
6. Stone thresholds.

B. Sealing of expansion, contraction, control, and isolation joints in tile surfaces is specified in Division 07 Section "Joint Sealant."

1.2 ACTION SUBMITTALS

A. Product data for each type of product specified.

B. Samples of each color of tile, marble threshold, or accessory to be provided, for verification purposes.

C. Samples of grout demonstrating full range of colors available, for initial selection purposes.

1.3 INFORMATIONAL SUBMITTALS

A. Qualification data for firms and persons specified in "Quality Assurance" article to demonstrate their capabilities and experience. Include list of completed projects with project names, addresses, names of Architects and Owners, plus other information specified.

1.4 QUALITY ASSURANCE

A. Single-Source Responsibility for Tile: Obtain each color, grade, finish, type, composition, and variety of tile from a single source with resources to provide products of consistent quality in appearance and physical properties without delaying progress of the Work.

B. Single-Source Responsibility for Setting and Grouting Materials: Obtain ingredients of a uniform quality from one manufacturer for each cementitious and admixture component and from one source or producer for each aggregate.

C. Installer Qualifications: Engage an experienced Installer who has successfully completed tile installations similar in material, design, and extent to that indicated for Project.

- D. Unit Mock-up: Provide mock-up on a board min. 2' x 2' in size, one for each different tile and grout color to be provided in the work; for final approval of grout color before ordering grout.
- E. In-Place Mock-up: Prepare mock-ups of types indicated below following requirements of this section. Reprepare mock-ups as many times as required by Architect until satisfactory result is obtained, as judged solely by Architect. Obtain Architect's approval of visual qualities before proceeding with work. Protect approved mock-ups until all work has been completed. Approved mock-ups will represent the minimum standard of acceptability for each portion of the work.
 - 1. Provide in-place sample minimum 5' x 5' of typical flooring layout in location directed by Architect.
 - 2. Provide mock-up of mosaic tile installed on one GFRG column as specified in Section 092800.

1.5 DELIVERY, STORAGE, AND HANDLING

- A. Deliver and store packaged materials in original containers with seals unbroken and labels intact until time of use. Comply with requirement of ANSI A137.1 for labeling sealed tile packages.
- B. Prevent damage or contamination to materials by water, freezing, foreign matter, and other causes.

1.6 PROJECT CONDITIONS

- A. Maintain environmental conditions and protect work during and after installation to comply with referenced standards and manufacturer's printed recommendations.
- B. Vent temporary heaters to exterior to prevent damage to tile work from carbon dioxide buildup.
- C. Maintain temperatures at 50 deg F (10 deg C) or more in tiled areas during installation and for 7 days after completion, unless higher temperatures are required by referenced installation standard or manufacturer's instructions.

1.7 EXTRA MATERIALS

- A. Extra Materials: Furnished from same production run as ceramic tile installed. Furnish 5% of each type and color of flooring material and 2% of each type and color of wall tile material provided in the work. Package materials with protective covering and identify with labels describing contents. Deliver extra materials to Owner.

PART 2 - PRODUCTS

2.1 MANUFACTURERS

- A. Basis-of-Design Manufacturers: The design for each tile type and other material specified is based on the product named. Subject to compliance with requirements, provide either the named product or a comparable product by one of the following manufacturers:
1. Tile:
 - a. American Olean; Div. of Dal-Tile International Corp
 - b. Creative Materials Corp.
 - c. Crossville Inc
 - d. Daltile; Div. of Dal-Tile International Inc.
 - e. Garden State Tile
 - f. Olympia Tile
 - g. Florida Tile Industries, Inc.
 - h. Summitville Tiles, Inc.
 - i. United States Ceramic Tile Company
 2. Mortars and Grouts:
 - a. Bostik Construction Products Div. (Hydroment)
 - b. Laticrete International Inc.
 - c. Mapei Corp.
 - d. TEC Specialty Construction Brands Inc.
 3. Waterproofing Membranes: The Noble Co.
 4. Termination, Trim and Transition Strips: Schluter

2.2 PRODUCTS, GENERAL

- A. ANSI Standard for Ceramic Tile: Comply with ANSI A137.1 "American National Standard Specifications for Ceramic Tile" for types, compositions, and grades of tile indicated.
1. Furnish tile complying with "Standard Grade" requirements unless otherwise indicated.
- B. ANSI Standard for Tile Installation Materials: Comply with ANSI standard referenced with products and materials indicated for setting and grouting.
- C. Colors, Textures, and Patterns: Where manufacturer's standard products are indicated for tile, grout, and other products requiring selection of colors, surface textures, patterns, and other appearance characteristics, provide specific products or materials complying with the following requirements:
1. Match color, texture, and pattern indicated by reference to manufacturer's standard designations for these characteristics.
 2. Provide tile trim and accessories that match color and finish of adjoining flat tile.
- D. Factory Blending: For tile exhibiting color variations within the ranges selected during sample submittals, blend tile in factory and package accordingly so that tile units taken from one package show the same range in colors as those taken from other packages and match approved samples.

- E. Large Format Tiles: Large format tiles are defined to be tiles with any one single side larger than 15".

2.3 TILE PRODUCTS

- A. Porcelain Floor Tile FT1: Provide flat tile complying with the following requirements:

1. Module Size: 12" x 24"
2. Thickness: 3/8"
3. Finish: Matte
4. Color: Park Lane Gray SO47
5. Basis of Design Product: Daltile "Society" or equal.
6. Location: Single user toilet rooms
7. Pattern: Running bond 1/3 overlap.
8. Grout Color: Laticrete #78 Sterling Silver

- B. Porcelain Floor Tile FT2: Provide flat tile complying with the following requirements:

1. Module Size: 12" x 24"
2. Thickness: 9.5mm
3. Finish: Velvet
4. Color: Grigio
5. Basis of Design Product: "Purestone" by Ceramiche Piemme or equal.
6. Location: At ramps where scheduled.
7. Pattern: Running bond 1/3 overlap.
8. Grout Color: Laticrete #89 Smoke Grey

- C. Quarry Tile Floor QT: Provide flat tile complying with the following requirements:

1. Module Size: 8" x 8"
2. Thickness: 1/2"
3. Finish: Textured, matte finish
4. Surface: Non-abrasive
5. Color: Ashen Grey OTO3
6. Basis of Design Product: Daltile "Quarry Tile Textures" or equal.
7. Location: Kitchen/food service
8. Grout Color: Laticrete #24 Natural Grey

- D. Porcelain Wall Tile WT1 through WT4: Provide flat tile complying with the following requirements:

1. Module Size: 12" x 24" rectified
2. Thickness: 8 mm
3. Finish: Polished
4. Colors: See Drawing A508 for wall finish elevation types which include a combination of the colors for all walls; combination vary on each level. Colors include:
 - a. PT1-Grey #11
 - b. PT2-Grey #12

- c. PT5-Turquoise 11
 - d. PT3-Blue 12
 - e. PT4-Bright Green 11.
5. Basis of Design Product: Creative Materials Corp. "Bellissimo" or equal.
 6. Location: Corridors
 7. Pattern: Running bond 1/3 overlap.
 8. Grout Color: Laticrete #89 Smoke Grey and/or #78 Sterling Silver as determined during mock-up preparation.
- E. Porcelain Mosaic Wall Tile WT6 through WT8: Provide flat tile complying with the following requirements:
1. Module Size: 1 by 1 inches
 2. Sheet Size: 12" x 12"
 3. Nominal Thickness: 3/16 inch.
 4. Mount Type: Mesh mounted.
 5. Shape: Penny rounds
 6. Finish: Gloss
 7. Colors:
 - a. WT6: RR07 Yellow
 - b. WT7: RR11 Cobalt Circle
 - c. WT8: RR12 Smoky Gray
 8. Basis of Design Product: Daltile "Retro Rounds" or equal.
 9. Location: Accent at Cafeteria.
 10. Grout Color:
 - a. WT6: Laticrete #44 Bright White
 - b. WT7 and WT8: Laticrete #42 Platinum and/or #88 Silver Shadow as determined during mock-up preparation
- F. Ceramic Wall Tile WT9: Provide flat tile complying with the following requirements:
1. Module Size: 3" x 9"
 2. Thickness: 10mm
 3. Finish: Glossy
 4. Color: White
 5. Basis of Design Product: Creative Materials Corp. "Coloration" or equal.
 6. Location: Multiuser toilet room field
 7. Pattern: Running bond 1/3 overlap.
 8. Grout Color: Laticrete #42 Platinum, final approval as determined during mock-up preparation.
- G. Ceramic Wall Tile WT10: Provide flat tile complying with the following requirements:
1. Module Size: 3" x 9"
 2. Thickness: 10mm
 3. Finish: Gloss
 4. Colors:

- a. CT1 Accent on Second Floor: Green 03
 - b. CT2 Accent on Third Floor- Blue 02)
 - c. CT3 Accent on 4th floor- Blue 05
 - d. CT4 Accent at Entry on First Floor Classrooms- Coloration Yellow 01
5. Basis of Design Product: Creative Materials Corp. "Coloration" or equal
 6. Location: Accent at toilet rooms, unless otherwise indicated.
 7. Pattern: Running bond 1/3 overlap.
 8. Grout Color: Laticrete #44 Bright White
- H. Ceramic Wall Tile WT11: Provide flat tile complying with the following requirements:
1. Module Size: 3" x 6"
 2. Thickness: 5/16"
 3. Finish: Glossy
 4. Color: Arctic White 0190
 5. Basis of Design Product: Daltile "Colorwheel Collection - Classic" or equal.
 6. Location: Single user toilet rooms field
 7. Pattern: Running bond 1/3 overlap.
 8. Grout Color: Laticrete #44 Bright White
- I. Ceramic Wall Tile WT12: Provide flat tile complying with the following requirements:
1. Module Size: 8" x 8"
 2. Finish: Matte
 3. Color/Pattern: Sapphire Colours
 4. Basis of Design Product: Wayne Tile "Valencia" or equal.
 5. Location: Circulation desk in Learning Commons.
 6. Grout Color: Laticrete #88 Silver Shadow
- J. Porcelain Wall Tile WT13: Provide flat tile complying with the following requirements:
1. Module Size: 12" x 24"
 2. Thickness: 8 mm
 3. Finish: Matte
 4. Color: Linen
 5. Basis of Design Product: Garden State Tile "Quill" or equal.
 6. Location: Lobby walls
 7. Installation: Install on end (vertically) running bond
 8. Grout Color: Laticrete #90 Light Pewter, final approval as determined during mock-up preparation.
- K. Trim Units: Provide tile trim units with inside and outside corners and to comply with following requirements:
1. Ceramic Wall Base WTB: Sanitary cove base Daltile Classic Collection , 6"H Color: Desert Grey X114.
 - a. Base with Flat Top: Provide at all single user toilet rooms.

- b. Base with Bullnose Cap: Provide at Community Building basement (locker rooms) toilet rooms.
 - c. Grout Color: Match floor tile; provide Laticrete #78 Sterling Silver.
2. Quarry Tile Base: Daltile cove base Q3585 4" x 8" matching quarry tile floors.
 - a. Grout Color: Match floor tile; provide Laticrete #24 Natural Grey.
 3. For Coordination Purposes: Precast terrazzo sanitary base 6"h at Multiuser toilet rooms to match specified flooring color (terrazzo base is specified in Section 096623.)
 4. Single User Toilet Room: At wainscot height tile cap with Daltile Jolly S-1/212J, ½" x 12" in Arctic White

2.4 STONE AND PRE-CAST TERRAZZO THRESHOLDS

- A. General: Provide stone that is uniform in color and finish, fabricated to sizes and profiles indicated or required to provide transition between tile surfaces and adjoining finished floor surfaces.
 1. Bevel edges at 1:2 slope, aligning lower edge of bevel with adjacent floor finish. Limit height of bevel to 1/2 inch (12.7 mm) or less, and finish bevel to match face of threshold.
- B. Marble Thresholds: Provide marble thresholds complying with ASTM C 503 requirements for exterior use and for abrasion resistance where exposed to foot traffic, a minimum hardness of 10 per ASTM C 241.
 1. Provide white marble thresholds.
 2. Provide at single-user toilet rooms, locker room, gender neutral loading dock toilet room, and elsewhere as scheduled.
- C. Precast Terrazzo Thresholds: Provide at toilet room locations where scheduled, thresholds shall match adjacent terrazzo floors; terrazzo thresholds are specified in Section 096623.

2.5 WATERPROOFING/CRACK ISOLATION FOR TILE INSTALLATIONS

- A. General: Provide products that comply with ANSI A118.10 and the descriptions in this Article.
- B. Polyethylene-Sheet Waterproofing: Manufacturer's standard proprietary product consisting of composite sheets, 60 inches (1524 mm) wide by a nominal thickness of 0.030-inch (0.76 mm), composed of an inner layer of nonplasticized, chlorinated polyethylene sheet faced on both sides with laminated, high-strength, nonwoven polyester material, designed for embedding in latex-portland cement mortar and as the substrate for latex-portland cement mortar setting bed. Provide at all locations for thin-setting.
 1. Products: Provide Nobleseal TS manufactured by the Noble Company, or approved equal.

2. Location: Use at all thin set tile floors in bathrooms.

2.6 SETTING MATERIALS

- A. Medium-Bed, Latex-Portland Cement Mortar. Comply with requirements in ANSI A118.4. Provide product that is approved by manufacturer for application thickness of up to 3/4 inch. Provide one of the following, or approved equal:
 1. MegaLite® Ultimate Crack Prevention Large Format Tile Mortar by Custom Building Products.
 2. 4-XLT by Laticrete.
 3. Large Tile and Stone Mortar by Mapei
- B. Latex-Portland Cement Mortar: Two component mortar system, comply with ANSI A118.4. Provide one of the following, or approved equal:
 1. Laticrete 317 with Laticrete 333 additive; Laticrete International, Inc.
 2. Kerabond with Keralastic; Mapei Corp.
 3. Or equivalent.

2.7 GROUTING MATERIALS

- A. Water-Cleanable Epoxy Grout for General Use: ANSI A118.3. with a VOC content of 65 g/L or less when calculated according to 40 CFR 59, Subpart D (EPA Method 24). Grout shall be stain resistant, color fast, mold and mildew inhibiting, non-sag, suitable for joints 1/16" to 1/2" and sanded type suitable for installing with glazed tiles.
 1. Basis of Design Product: Laticrete "Spectralock Pro Epoxy Grout" or equal.
 2. Colors: As selected by Architect.
- B. Chemical-Resistant Epoxy Grout for Unglazed Quarry Tile: ANSI A118.3; provide the following, or approved equal, in colors as selected by Architect:
 1. SP-100 Stainless Epoxy Grout; Laticrete International, Inc.
 2. Kerapoxy; Mapei Corp

2.8 MISCELLANEOUS MATERIALS

- A. Metal Edge Strips: Zinc alloy or stainless steel terrazzo strips, 1/8-inch wide at top edge with integral provision for anchorage to mortar bed or substrate unless otherwise indicated.
- B. Notched Trowel: Use type recommended by tile manufacturer for setting large-format tiles, for setting bed thickness utilized.
- C. Termination, Trim and Transition Strips: Provide Schluter units in Type 304 stainless steel as scheduled below, or indicated on Drawings.
 1. At all floor tile color transitions provide Schluter "SCHIENE E-100".

2. Wall Tile Outside Corners Trim and Top Cap of Corridor Wall Tile: RONDEC by Schluter or equal.
 - D. Trowelable Underlayments and Patching Compounds: Latex-modified, portland-cement-based formulation provided or approved by tile manufacturer for applications indicated.
 - E. Grout Release: Product indicated below that is formulated to protect exposed surfaces of tile against adherence of mortar and grout; compatible with tile, mortar, and grout products; and easily removable after grouting is completed without damaging grout or tile.
 1. Mapei "UltraCare Grout Release".
 2. Miracle Sealants Co. "511 Impregnator"
 - F. Tile Cleaner: A neutral cleaner capable of removing soil and residue without harming tile and grout surfaces, specifically approved for materials and installations indicated by tile and grout manufacturers.
 - G. Grout Sealers: Water-based sealer for tile for protection from stains, as follows:
 1. Mapei "UltraCare Grout Sealer".
 2. Miracle Sealants Co. "511 Impregnator"
- 2.9 MIXING MORTARS AND GROUT
- A. Mix mortars and grouts to comply with requirements of referenced standards and manufacturers including those for accurate proportioning of materials, water, or additive content; type of mixing equipment, selection of mixer speeds, mixing containers, mixing time, and other procedures needed to produce mortars and grouts of uniform quality with optimum performance characteristics for application indicated.

PART 3 - EXECUTION

3.1 EXAMINATION

- A. Examine substrates and areas where tile will be installed, with Installer present, for compliance with requirements for installation tolerances and other conditions affecting performance of installed tile.
 1. Verify that substrates for setting tile are firm, dry, clean, and free from oil or waxy films and curing compounds.
 2. Verify that installation of grounds, anchors, recessed frames, electrical and mechanical units of work, and similar items located in or behind tile has been completed before installing tile.
 3. Verify that subfloors are free of cracks, ridges, depressions, scale, and foreign deposits of any kind.
 4. Perform moisture test at rate of one per 2,000 sq.ft.

5. Verify that concrete substrates are within the flatness tolerances required for setting large format tiles.

- B. Do not proceed with installation until unsatisfactory conditions have been corrected.

3.2 PREPARATION

- A. General: Comply with manufacturer's installation specifications to prepare substrates indicated to receive tile.
- B. Use trowelable leveling and patching compounds per manufacturer's directions to fill cracks, holes, and depressions in substrates and to patch and level floors as required to provide suitable substrate for tile application.
- C. Remove coatings, including curing compounds, and other substances that could interfere with adhesion of tile by using a grinder, sander, or polishing machine with a heavy-duty wire brush.
- D. Broom or vacuum clean substrates to be covered by tiles immediately before tile installation. Following cleaning, examine substrates for moisture, alkaline salts, carbonation, or dust.
- E. Blending: For tile exhibiting color variations within the ranges selected during sample submittals, verify that tile has been blended in factory and packaged accordingly so that tile units taken from one package show the same range in colors as those taken from other packages and match approved samples. If not factory blended, either return to manufacturer or blend tiles at Project site before installing.
- F. Transitions: Transitions of floor surfaces must be level. Use transition and edge pieces as required to obtain level abutting surfaces, meeting ADA requirements.
- G. For large format tiles thin-set with medium bed mortar, provide the following surface preparation:
 1. Level substrates to 1/8-inch variance in 10 feet, with no more than 1/16 inch variation in 24 inches by one of the following methods:
 - a. Provide self-leveling hydraulic cement underlayment throughout project where new floor tile is installed.
 - b. Grind concrete floor substrates and patch with trowelable leveling and patching compound to achieve indicated flatness.
 - c. Skim coat and patch wall surfaces using manufacturer approved trowel-applied cement-based compound to bring surface into acceptable tolerances.
 2. There shall be no abrupt irregularities greater than 1/32"

3.3 INSTALLATION, GENERAL

- A. ANSI Tile Installation Standard: Comply with parts of ANSI 108 series of tile installation standards included under "American National Standard Specifications for the Installation

of Ceramic Tile" that apply to type of setting and grouting materials and methods indicated.

- B. TCNA Installation Guidelines: TCNA "Handbook for Ceramic Tile Installation"; comply with TCNA installation methods indicated.
- C. Extend tile work into recesses and under or behind equipment and fixtures to form a complete covering without interruptions except as otherwise shown. Terminate work neatly at obstructions, edges, and corners without disrupting pattern or joint alignments.
- D. Accurately form intersections and returns. Perform cutting and drilling of tile without marring visible surfaces. Carefully grind cut edges of tile abutting trim, finish, or built-in items for straight aligned joints. Fit tile closely to electrical outlets, piping, fixtures, and other penetrations so that plates, collars, or covers overlap tile.
 - 1. Cut and grind tile edges where they abut curved surfaces to produce a close and uniform abutting joint.
- E. Jointing Pattern: Lay tile in grid pattern. Align joints when adjoining tiles on floor, base, walls, and trim are same size. Lay out tile work and center tile fields in both directions in each space or on each wall area. Adjust to minimize tile cutting. Provide uniform joint widths unless otherwise shown.
 - 1. For tile mounted in sheets, make joints between tile sheets same width as joints within tile sheets so that extent of each sheet is not apparent in finished work
- F. Tile Patterns: Comply with pattern indicated on drawings.
- G. Expansion Joints: Provide expansion joints, control joints and pressure relieving joints of widths and at locations as per TCNA Handbook Construction #EJ171. Do not saw cut joints after installation of tiles.
 - 1. Sealing of joints is included in Division 07 Section "Joint Sealers."
- H. Apply grout release to tile surfaces prior to grouting. Prepare a small mock-up area of grout release application for Architect's approval before proceeding with application of grout release to installed tile surfaces.
- I. Grout tile to comply with ANSI A108.10.

3.4 WATERPROOFING INSTALLATION

- A. Install waterproofing to comply with waterproofing manufacturer's written instructions to produce a waterproof membrane of uniform thickness bonded securely to substrate.
- B. Do not install tile over waterproofing until waterproofing has cured and been tested to determine that it is watertight.

3.5 FLOOR INSTALLATION METHODS

- A. Floor Tile: Install tile to comply with requirements indicated below for setting bed methods, TCNA installation methods related to types of subfloor construction, and grout types:
1. Concrete subfloor, TCNA F205, modified to comply with tile manufacturer's installation instructions, and as follows:
 - a. Bond Coat for Tile: Medium-Bed, Latex-Portland Cement Mortar, ANSI A108.5 over subfloor.
 - b. Grout: Epoxy grout specified for general use.
 - c. Setting bed thickness shall be as required to produce finished floor surface at correct level for project.
 - d. Provide at non-wet floors.
 2. Concrete subfloor with waterproofing/crack suppression membrane, TCNA F205 modified to comply with membrane manufacturer's installation instructions, details on drawings and as follows:
 - a. Bond Coat for Membrane: Medium-Bed, Latex-Portland Cement Mortar, ANSI A108.5 over subfloor.
 - b. Sheet membrane over bond coat, extend up walls 4 inches
 - c. Bond Coat for Tile: Medium-Bed, Latex-Portland Cement Mortar—ANSI A108.5 over membrane
 - d. Grout: Epoxy grout specified for general use.
 - e. Provide at toilet room floors.
 3. Quarry Tile, Concrete subfloor, TCNA F113 (thin set application), and as follows:
 - a. Bond Coat for Tile: Latex-portland cement mortar, ANSI A108.5 over subfloor.
 - b. Apply grout release prior to grouting.
 - c. Grout: Epoxy grout specified for quarry tile.
- B. Joint Widths:
1. Porcelain Tile: 3/32".
 2. Quarry Tile: 3/8"
- C. Metal Edge Strips: Install at locations indicated or where exposed edge of tile flooring meets carpet, wood, or other flooring that finishes flush with top of tile.
- D. Transition Strips: Install at all edges where new tile meets existing flooring to ensure a smooth transition meeting ADA requirements.
- E. Stone and Pre-Cast Terrazzo Thresholds: Install stone thresholds at tile transitions at restrooms. Allow for bevel/chamfer as required. Set in same type of setting bed as abutting field tile unless otherwise indicated. Sealant is specified in Section 079200.

3.6 WALL INSTALLATION METHODS

- A. Wall Tile: Install tile to comply with requirements indicated below for setting-bed methods, TCNA installation methods related to subsurface wall conditions, and grout types:
 - 1. Gypsum Board and Cement Board - TCNA W243, and as follows:
 - a. Bond Coat for Tile: Latex-portland cement mortar, ANSI A108.5 over gypsum board.
 - b. Grout: Epoxy.
 - 2. Concrete Masonry Units - TCNA W202, and as follows:
 - a. Bond Coat for Large Format Tile: Medium-Bed, Latex-Portland Cement Mortar, ANSI A108.5 over concrete masonry units.
 - b. Bond Coat for Other Tile: Latex-portland cement mortar, ANSI A108.5, over concrete masonry units.
 - c. Grout: Epoxy
- B. Joint Widths: 1/16".

3.7 CLEANING AND PROTECTION

- A. Cleaning: Upon completion of placement and grouting, clean all ceramic tile surfaces so they are free of foreign matter.
 - 1. Remove grout residue from tile as soon as possible.
 - 2. Unglazed tile may be cleaned with acid solutions only when permitted by tile and grout manufacturer's printed instructions, but no sooner than 14 days after installation. Protect metal surfaces, cast iron, and vitreous plumbing fixtures from effects of acid cleaning. Flush surface with clean water before and after cleaning.
- B. Finished Tile Work: Leave finished installation clean and free of cracked, chipped, broken, unbonded, and otherwise defective tile work.
- C. Provide final protection and maintain conditions in a manner acceptable to manufacturer and installer that ensures that tile is without damage or deterioration at time of Substantial Completion.
 - 1. Prohibit foot and wheel traffic from tiled floors for at least 7 days after grouting is completed.
- D. Before final inspection, remove protective coverings and rinse neutral cleaner from tile surfaces.

END OF SECTION 093100

The following additions, substitutions, or clarifications are extracted from the (5) Bid Addenda issued with this project during bidding. This insert is intended to summarize addendum information relevant to this specification section. See Bid Addenda issued by the City of Yonkers for complete contract document changes.

Bid Addendum No. 4:

Part 2 products- 2.2 C. The cafeteria ceiling tile changes to ACT1 as specified.

SECTION 095113 - ACOUSTICAL PANEL CEILINGS

PART 1 - GENERAL

1.1 SUMMARY

- A. This Section includes ceilings consisting of acoustical panels and exposed suspension systems.
- B. Related Sections include the following:
 - 1. Acoustical sealants are specified in Division 07 Section "Joint Sealants"

1.2 ACTION SUBMITTALS

- A. Product Data: For each type of product specified
- B. Coordination Drawings: Reflected ceiling plans drawn to scale and coordinating penetrations and ceiling-mounted items. Show the following:
 - 1. Ceiling suspension members.
 - 2. Method of attaching hangers to building structure.
 - 3. Ceiling-mounted items including lighting fixtures, diffusers, grilles, speakers, sprinklers, access panels, and special moldings.
 - 4. Minimum Drawing Scale: 1:100
- C. Samples for Verification: For each component indicated and for each exposed finish required, prepared on samples of size indicated below.
 - 1. 6-inch- (150-mm-) square samples of each acoustical panel type, pattern, and color.
 - 2. Set of 12-inch- (300-mm-) long samples of exposed suspension system members, including moldings, for each color and system type required.

1.3 INFORMATIONAL SUBMITTALS

- A. Product Test Reports: Indicate compliance of acoustical panel ceilings and components with requirements based on comprehensive testing of current products.
- B. Research/Evaluation Reports: Evidence of acoustical panel ceiling's and components' compliance with building code in effect for Project, from a model code organization acceptable to authorities having jurisdiction.
- C. Maintenance Data: For finishes to include in maintenance manuals.

1.4 QUALITY ASSURANCE

- A. Installer Qualifications: Engage an experienced installer who has completed acoustical panel ceilings similar in material, design, and extent to that indicated for this Project and with a record of successful in-service performance.
- B. Source Limitations: Obtain each type of acoustical ceiling panel and supporting suspension system through one source from a single manufacturer..
- C. Fire-Test-Response Characteristics: Provide acoustical panel ceilings that comply with the following requirements:
 - 1. Fire-Resistance Characteristics: Where indicated, provide acoustical panel ceilings identical to those of assemblies tested for fire resistance per ASTM E 119 by UL or another testing and inspecting agency acceptable to authorities having jurisdiction.
 - a. Fire-Resistance Ratings: Indicated by design designations from UL's "Fire Resistance Directory" or from the listings of another testing and inspecting agency .
 - b. Identify materials with appropriate markings of applicable testing and inspecting agency.
 - 2. Surface-Burning Characteristics: Provide acoustical panels with the following surface-burning characteristics complying with ASTM E 1264 for Class A materials as determined by testing identical products per ASTM E 84:
 - a. Smoke-Developed Index: 450 or less

1.5 DELIVERY, STORAGE, AND HANDLING

- A. Deliver acoustical panels and suspension system components to Project site in original, unopened packages and store them in a fully enclosed space where they will be protected against damage from moisture, direct sunlight, surface contamination, and other causes.
- B. Before installing acoustical panels, permit them to reach room temperature and a stabilized moisture content.
- C. Handle acoustical panels carefully to avoid chipping edges or damaging units in any way.

1.6 PROJECT CONDITIONS

- A. Environmental Limitations: Do not install acoustical panel ceilings until spaces are enclosed and weatherproof, wet-work in spaces is complete and dry, work above ceilings is complete, and ambient temperature and humidity conditions are maintained at the levels indicated for Project when occupied for its intended use.

1.7 COORDINATION

- A. Coordinate layout and installation of acoustical panels and suspension system with other construction that penetrates ceilings or is supported by them, including light fixtures, HVAC equipment, fire-suppression system, and partition assemblies.

1.8 EXTRA MATERIALS

- A. Extra Materials: Furnished from same production run as acoustical ceiling panels installed. Furnish 5% of each type and color of material provided in the work. Package materials with protective covering and identify with labels describing contents. Deliver extra materials to Owner.

PART 2 - PRODUCTS

2.1 MANUFACTURERS

- A. Basis of Design Products: Subject to compliance with requirements, provide specified products by Armstrong World Industries or equivalent products.

2.2 ACOUSTICAL PANELS

- A. Acoustical Panel Standard: Provide manufacturer's standard panels of configuration indicated that comply with ASTM E 1264 classifications as designated by types, patterns, acoustical ratings, and light reflectances, unless otherwise indicated.
 - 1. Mounting Method for Measuring Noise Reduction Coefficient: Type E-400; plenum mounting in which face of test specimen is 15-3/4 inches (400 mm) away from test surface per ASTM E 795.
 - 2. Provide fire-resistance rated panels where indicated.
- B. Acoustical Panels for Acoustical Panel Ceiling ACT 1: Where this designation is indicated, provide panels complying with the following:
 - 1. Classification: Panels fitting ASTM E 1264 for Type IV, wet-formed mineral fiber with membrane-faced overlay; Form 2, water felted.
 - 2. Pattern: Panels fitting ASTM E 1264 pattern designation (description) E (lightly textured).
 - 3. Color: White.
 - 4. Light Reflectance Coefficient: Not less than LR 0.85.
 - 5. Noise Reduction Coefficient: 0.85
 - 6. Ceiling Attenuation Class: 35
 - 7. AC: 170
 - 8. Fire Rating: Class A
 - 9. Sag Resistance Treatment: Armstrong HumiGuard Plus
 - 10. Anti-Mold and Mildew Treatment: BioBlock+
 - 11. VOC: GREENGUARD Gold Certified low VOC emissions
 - 12. Warranty: 30 year
 - 13. Edge Detail: Square tegular.
 - 14. Thickness: 1 inch.
 - 15. Size: 24 by 24 inches.
 - 16. Basis of Design Product: Armstrong CALLA #2822.
 - 17. Location: Corridors.

- C. Acoustical Panels for Acoustical Panel Ceiling ACT 2: Where this designation is indicated, provide panels complying with the following:
1. Classification: Panels fitting ASTM E 1264 for Type IV, wet-formed mineral fiber with membrane-faced overlay; Form 2, water felted.
 2. Pattern: Panels fitting ASTM E 1264 pattern designation (description) E (lightly textured).
 3. Color: White.
 4. Noise Reduction Coefficient: 0.85
 5. Ceiling Attenuation Class: 35
 6. AC: 170
 7. Fire Rating: Class A
 8. Sag Resistance Treatment: Armstrong HumiGuard Plus
 9. Anti-Mold and Mildew Treatment: BioBlock+
 10. VOC: GREENGUARD Gold Certified low VOC emissions
 11. Warranty: 30 year
 12. Edge Detail: Square tegular.
 13. Thickness: 1 inch.
 14. Size: 24 by 48 inches.
 15. Basis of Design Product: Armstrong CALLA #2823.
 16. Location: Cafeteria
- D. Acoustical Panels for Acoustical Panel Ceiling ACT3: Where this designation is indicated, provide acoustical panels complying with the following:
1. Classification: Panels fitting ASTM E 1264 for Type III, wet-formed mineral fiber with painted finish; Form 1, nodular.
 2. Pattern: Panels fitting ASTM E 1264 pattern designation (description) E (lightly textured).
 3. Color: White.
 4. Surface: Factory-applied latex paint
 5. Light Reflectance Coefficient: Not less than LR 0.85.
 6. Noise Reduction Coefficient: 0.75
 7. Ceiling Attenuation Class: 35
 8. AC: 170
 9. Fire Rating: Class A
 10. Sag Resistance Treatment: Armstrong HumiGuard Plus
 11. Anti-Mold and Mildew Treatment: BioBlock
 12. Low VOC Emissions: GREENGUARD Gold Certified
 13. Warranty: 30 year
 14. Edge Detail: Angled tegular
 15. Thickness: 7/8 inch.
 16. Size: 24 by 24 inches.
 17. Basis of Design Product: Armstrong Cirrus High NRC Tegular #556, or equal.
 18. Location: Classrooms.
- E. Acoustical Panels for Acoustical Panel Ceiling ACT4: Where this designation is indicated, provide panels complying with the following:

1. Classification: Panels fitting ASTM E 1264 for Type IX, mineral base with scrubbable pigmented or clear finish; Form 2, water felted.
2. Pattern: Panels fitting ASTM E 1264 pattern designation (description) G (smooth).
3. Color: White
4. Light Reflectance Coefficient: Not less than LR 0.89.
5. Noise Reduction Coefficient: N/A
6. Ceiling Attenuation Class: 33
7. AC: N/A
8. Fire Rating: Class A
9. Sag Resistance Treatment: Armstrong HumiGuard Plus
10. Anti-Mold and Mildew Treatment: BioBlock
11. Low VOC Emissions: GREENGUARD Gold Certified
12. Warranty: 30 years
13. Edge Detail: Square Lay-in.
14. Thickness: 5/8 inch.
15. Size: 24 by 24 inches.
16. Basis of Design Product: Armstrong Kitchen Zone #673.
17. Location: Kitchen/ Servery

- F. Acoustical Panels for Music Room Ceiling: Panel consists of a 6 to 7 pcf density acoustically absorptive core, with a special high acoustic performance layer laminated to the face (1-1/16" overall thickness) which is designed to receive a non-bridging acoustically transparent coating. A 1 mil clear vapor barrier is adhered to panel back. Provide mounting clips on panel back to accommodate suspension system.

1. NRC: 0.85
2. L/R: 90%
3. Fire Rating: Class A
4. Weight: 1.05 psf.
5. Size: 3' x 8'.
6. Color: White CSW-100
7. Quantity: 9
8. Basis of Design Product: Decoustics Claro finish panels by CertainTeed Ceilings, or equal.

2.3 METAL SUSPENSION SYSTEMS

- A. Metal Suspension System Standard: Provide manufacturer's standard direct-hung metal suspension systems of types, structural classifications, and finishes indicated that comply with applicable ASTM C 635 requirements.

1. Provide fire-resistance rated metal suspension system where indicated

- B. Suspension System for Acoustical Panel Ceilings ACT1, ACT-2, ACT3 and ACT4: Wide-Face, Capped, Double-Web, Steel Suspension System: Main and cross runners roll formed from cold-rolled steel sheet, prepainted, electrolytically zinc coated, or hot-dip galvanized according to ASTM A 653/A 653M, G30 (Z120) coating designation, with prefinished 15/16-inch- (24-mm-) wide metal caps on flanges; other characteristics as follows:

1. Structural Classification: Intermediate-duty system.
 2. End Condition of Cross Runners: Override (stepped) or butt-edge type, as standard with manufacturer.
 3. Face Design: Flush face.
 4. Cap Material:
 - a. Steel sheet for ACT1 and 3.
 - b. Aluminum for ACT4.
 5. Cap Finish: Manufacturer's standard factory-applied painted finish in white.
 6. Basis of Design Product: Armstrong Prelude XL.
- C. Suspension System for Acoustical Ceiling in Music Room: Direct mount (attach with clips) F5 mounting.
- D. Attachment Devices: Size for five times design load indicated in ASTM C 635, Table 1, Direct Hung, unless otherwise indicated.
1. Power-Actuated Fasteners in Concrete: Fastener system of type suitable for application indicated, fabricated from corrosion-resistant materials, with clips or other accessory devices for attaching hangers of type indicated, and with capability to sustain, without failure, a load equal to 10 times that imposed by ceiling construction, as determined by testing per ASTM E 1190, conducted by a qualified testing and inspecting agency.
- E. Wire Hangers, Braces, and Ties: Provide wires complying with the following requirements:
1. Zinc-Coated Carbon-Steel Wire: ASTM A 641/A 641M, Class 1 zinc coating, soft temper.
 2. Size: Select wire diameter so its stress at three times hanger design load (ASTM C 635, Table 1, Direct Hung) will be less than yield stress of wire, but provide not less than 0.106-inch- (2.69-mm-) diameter wire.
- F. Metal Edge Moldings and Trim: Type and profile indicated or, if not indicated, manufacturer's standard moldings for edges and penetrations that fit acoustical panel edge details and suspension systems indicated; formed from sheet metal of same material, finish and color as that used for exposed flanges of suspension system runners.
- G. Hold-Down Clips: Where indicated or required for fire-rating, provide manufacturer's standard hold-down clips spaced 24 inches (610 mm) o.c. on all cross tees.
- 2.4 ACOUSTICAL SEALANT
- A. Refer to Division 07 Section "Joint Sealants".

PART 3 - EXECUTION

3.1 EXAMINATION

- A. Examine substrates and structural framing to which acoustical panel ceilings attach or abut, with Installer present, for compliance with requirements specified in this and other Sections that affect ceiling installation and anchorage, and other conditions affecting performance of acoustical panel ceilings.
- B. Proceed with installation only after unsatisfactory conditions have been corrected.

3.2 PREPARATION

- A. Coordination: Furnish layouts for cast-in-place anchors, clips, and other ceiling anchors whose installation is specified in other Sections.
- B. Measure each ceiling area and establish layout of acoustical panels to balance border widths at opposite edges of each ceiling. Avoid using less-than-half-width panels at borders, and comply with layout shown on reflected ceiling plans.

3.3 INSTALLATION

- A. General: Install acoustical panel ceilings to comply with publications referenced below per manufacturer's written instructions and CISCA's "Ceiling Systems Handbook."
 - 1. Standard for Ceiling Suspension System Installations: Comply with ASTM C 636.
 - 2. Fire-Rated Assembly: Install fire-rated ceiling systems according to tested fire-rated design.
- B. Suspend ceiling hangers from building's structural members and as follows:
 - 1. Install hangers plumb and free from contact with insulation or other objects within ceiling plenum that are not part of supporting structure or of ceiling suspension system.
 - 2. Splay hangers only where required to miss obstructions; offset resulting horizontal forces by bracing, countersplaying, or other equally effective means.
 - 3. Where width of ducts and other construction within ceiling plenum produces hanger spacings that interfere with location of hangers at spacings required to support standard suspension system members, install supplemental suspension members and hangers in form of trapezes or equivalent devices. Size supplemental suspension members and hangers to support ceiling loads within performance limits established by referenced standards and publications.
 - 4. Secure wire hangers to ceiling suspension members and to supports above with a minimum of three tight turns. Connect hangers directly either to structures or to inserts, eye screws, or other devices that are secure; that are appropriate for substrate; and that will not deteriorate or otherwise fail due to age, corrosion, or elevated temperatures.
 - 5. Do not attach hangers to steel deck tabs.
 - 6. Do not attach hangers to steel roof deck. Attach hangers to structural members.

7. Space hangers not more than 48 inches (1200 mm) o.c. along each member supported directly from hangers, unless otherwise indicated; and provide hangers not more than 8 inches (200 mm) from ends of each member.
- C. Install edge moldings and trim of type indicated at perimeter of acoustical ceiling area and where necessary to conceal edges of acoustical panels.
1. Apply acoustical sealant in a continuous ribbon concealed on back of vertical legs of moldings before they are installed.
 2. Screw attach moldings to substrate at intervals not more than 16 inches (400 mm) o.c. and not more than 3 inches (75 mm) from ends, leveling with ceiling suspension system to a tolerance of 1/8 inch in 12 feet (3 mm in 3.6 m). Miter corners accurately and connect securely.
 3. Do not use exposed fasteners, including pop rivets, on moldings and trim.
- D. Install suspension system runners so they are square and securely interlocked with one another. Remove and replace dented, bent, or kinked members.
- E. Install acoustical panels with undamaged edges and fitted accurately into suspension system runners and edge moldings. Scribe and cut panels at borders and penetrations to provide a neat, precise fit.
1. Arrange directionally patterned acoustical panels as indicated on reflected ceiling plans.
 2. Install hold-down clips in areas indicated, in areas required by authorities having jurisdiction, and for fire-resistance ratings; space as recommended by panel manufacturer's written instructions, unless otherwise indicated.

3.4 CLEANING

- A. Clean exposed surfaces of acoustical panel ceilings, including trim, edge moldings, and suspension system members. Comply with manufacturer's written instructions for cleaning and touchup of minor finish damage. Remove and replace ceiling components that cannot be successfully cleaned and repaired to permanently eliminate evidence of damage.

END OF SECTION 095113

SECTION 095116 - ACOUSTIC BOARD CEILING PANELS

PART 1 - GENERAL

1.1 SUMMARY

- A. This Section includes Tectum acoustical board panels installed as follows:
 - 1. Direct mounted to ceiling surfaces.
- B. Related Sections include the following:
 - 1. Acoustical sealants are specified in Division 07 Section "Joint Sealants"
 - 2. Concealed suspension systems for Tectum panels are specified in Division 09 Section "Non-Structural Metal Framing"
 - 3. Field painting of Tectum panels is specified in Division 09 Section "Painting."

1.2 ACTION SUBMITTALS

- A. Product data for each type of product specified. Include data on physical characteristics, material densities, fastening and attachment methods, acoustical performance data, and flame resistance characteristics.
- B. Coordination Drawings: Reflected ceiling plans drawn to scale and coordinating penetrations and ceiling-mounted items. Show the following:
 - 1. Ceiling suspension members.
 - 2. Method of attaching hangers to building structure.
 - 3. Ceiling-mounted items including lighting fixtures, diffusers, grilles, speakers, sprinklers, access panels, and special moldings.
 - 4. Minimum Drawing Scale: 1:100

1.3 INFORMATIONAL SUBMITTALS

- A. Product certificates signed by acoustic board manufacturer certifying materials furnished comply with specified requirements.
- B. Certified test reports showing compliance with requirements for fire performance characteristics and physical properties.
- C. Maintenance Data: For finishes to include in maintenance manuals.

1.4 QUALITY ASSURANCE

- A. Fire Performance Characteristics: Provide acoustic boards with the following surface burning characteristics as determined by testing identical products per ASTM E 84 by UL or other testing and inspecting organizations acceptable to authorities having jurisdiction.

Identify acoustic boards with appropriate markings of applicable testing and inspecting organization.

1. Flame Spread: 25 or less.
2. Smoke Developed: 450 or less.

B. Installer Qualifications: Arrange for installation of acoustic boards by a firm that can demonstrate successful experience in installing similar in type and quality to those required for this Project.

C. Source Limitations: Obtain each type of acoustical board and supporting suspension system through one source from a single manufacturer.

1.5 DELIVERY, STORAGE, AND HANDLING

A. Protect units during transit, delivery, storage, and handling to prevent damage, soilage, and deterioration.

B. Before installing acoustical panels, permit them to reach room temperature and a stabilized moisture content.

1.6 PROJECT CONDITIONS

A. Maintain a constant temperature not less than 70°F in installation areas for at least ten (10) days before and ten (10) days after installation.

B. Field Measurements: Where units are indicated to be fitted to other construction, check actual dimensions of other construction by accurate field measurements; show recorded measurements on final shop drawings. Coordinate manufacturing schedule with construction progress to avoid delay of Work.

1.7 COORDINATION

A. Coordinate layout and installation of acoustical board panels and suspension system with other construction that penetrates ceilings or is supported by them, including light fixtures, HVAC equipment, fire-suppression system, and partition assemblies..

PART 2 - PRODUCTS

2.1 MANUFACTURERS:

A. Basis-of-Design Manufacturer: Subject to compliance with requirements, provide acoustic board and suspension systems manufactured by Armstrong World Industries or an approved equivalent.

2.2 ACOUSTIC BOARDS:

- A. Acoustic Board Ceiling Panels: Aspen wood fibers bonded with inorganic hydraulic cement. Product shall comply with the following:
 - 1. Size: 4' x 8'.
 - 2. Thickness: 1".
 - 3. Surface Burning/Flame Spread Characteristics: Class A.
 - 4. Edges: Long edges beveled, square ends.
 - 5. NRC: .90
 - 6. Color: Natural, for field painting.
 - 7. Mounting Method: For direct application to ceiling surfaces using 3/4" furring channels (similar to D20 mounting).
 - 8. Warranty: 30 years.
 - 9. Basis of Design Product: "Tectum Finale" by Armstrong World Industries, or approved equivalent

2.3 MOUNTING SYSTEMS AND MATERIALS

- A. Concealed Suspension Systems for Tectum Panels: Armstrong World Industries, Inc.; Drywall Grid Systems; refer to Division 09 Section "Non-Structural Metal Framing" for specifications. Provide all required hangars and all other components as specified in this section.
- B. Fasteners: Provided by or approved by manufacturer for installation conditions indicated.
- C. Adhesive: Manufacturer's standard low odor, VOC compliant, non-flammable latex based adhesive recommended for use and substrate.

PART 3 - EXECUTION

3.1 EXAMINATION

- A. Examine substrates and structural framing to which acoustical board ceilings attach or abut, with Installer present, for compliance with requirements specified in this and other Sections that affect ceiling installation and anchorage, and other conditions affecting performance of acoustical panel ceilings.
- B. Proceed with installation only after unsatisfactory conditions have been corrected

3.2 PREPARATION

- A. For direct application, clean substrates of projections and substances detrimental to application of panels. Follow manufacturer's printed instructions for surface preparation.
- B. Acclimate acoustic boards to room temperature for 48 hours prior to installation.
- C. Coordination: Furnish layouts for cast-in-place anchors, clips, and other ceiling anchors whose installation is specified in other Sections.

- D. Measure each ceiling area and establish layout of acoustical panels to balance border widths at opposite edges of each ceiling. Avoid using less-than-half-width panels at borders, and comply with layout shown on reflected ceiling plans.
- E. Field paint Tectum panels prior to installation.
 - 1. Field painting is specified in Division 09 Section "Painting".

3.3 INSTALLATION

- A. Do not use materials that are unsound, warped, bowed or twisted.
- B. Install acoustic boards plumb, level, true, and aligned with adjacent materials.
 - 1. Scribe and cut acoustic boards to fit adjoining work.
 - 2. Install to tolerance of 1/32 inch in 8 feet for plumb and level.
 - 3. Coordinate with materials and systems that may be in or adjacent to acoustic boards. Provide cutouts for mechanical and electrical items that penetrate.
 - 4. Install in accordance with approved shop drawings.
- C. Surface Application of Tectum Panels: Plan acoustic board layout, balancing acoustic board sizes at corners. Mechanically fasten and adhere acoustic boards to substrate in accordance with manufacturer's written instructions. Stagger joints between acoustic boards and substrate material.
- D. Concealed Suspension System Mounting of Tectum Panels: Install concealed drywall suspension system as specified in Division 09 Section "Non-Structural Metal Framing". Mechanically fasten acoustic boards to framing system in accordance with manufacturer's written instructions.
- E. Install edge moldings and trim of type indicated at perimeter of acoustical ceiling area and where necessary to conceal edges of acoustical panels. Comply with manufacturer's written installation instructions.

3.4 ADJUSTING AND CLEANING

- A. Repair damaged or defective acoustic boards where possible to eliminate functional or visual defects. Where not possible to repair, replace acoustic boards.
- B. Remove excess adhesive at finished seams, perimeter edges, and adjacent surfaces.
- C. Use cleaning methods recommended by the acoustic board manufacturer.
- D. Replace acoustic boards that cannot be cleaned.

3.5 PROTECTION

- A. Provide final protection and maintain conditions that ensure acoustic boards are without damage or deterioration at time of Substantial Completion.

13 January 2022
Conformed Specifications
SED #66-23-00-01-0-346-001

Yonkers Joint Schools Construction Board
Community School 35

END OF SECTION 095116

SECTION 095429 - WOOD PANEL ACOUSTICAL CEILING SYSTEMS

PART 1 - GENERAL

1.1 SUMMARY

- A. This Section includes acoustical wood perforated panels and suspension system.

1.2 ACTION SUBMITTALS

- A. Product Data: For each type of product specified
- B. Coordination Drawings: Reflected ceiling plans drawn to scale and coordinating penetrations and ceiling-mounted items. Show the following:
 - 1. Ceiling suspension members.
 - 2. Method of attaching hangers to building structure.
 - 3. Ceiling-mounted items including lighting fixtures, diffusers, grilles, speakers, sprinklers, access panels, and special moldings.
 - 4. Minimum Drawing Scale: 1:100
- C. Samples for Verification: For each component indicated and for each exposed finish required, prepared on samples of size indicated below.
 - 1. 12-inch- (300-mm-) square samples of each panel type, pattern, and color.
 - 2. Set of 12-inch- (300-mm-) long samples of exposed suspension system members, including moldings, for each color and system type required.

1.3 INFORMATIONAL SUBMITTALS

- A. Product Test Reports: Indicate compliance of panel ceilings system with requirements based on comprehensive testing of current products.
- B. Research/Evaluation Reports: Evidence of panel ceiling's compliance with building code in effect for Project, from a model code organization acceptable to authorities having jurisdiction.
- C. Maintenance Data: For finishes to include in maintenance manuals.

1.4 QUALITY ASSURANCE

- A. Installer Qualifications: Engage an experienced installer who has completed wood acoustical panel ceilings similar in material, design, and extent to that indicated for this Project and with a record of successful in-service performance.
- B. Source Limitations: Obtain each type of wood acoustical panel system through one source from a single manufacturer.

- C. Fire-Test-Response Characteristics: Provide wood acoustic panel ceilings and walls that comply with the following requirements:
 - 1. Surface-Burning Characteristics: Provide wood acoustic panels meeting Class A requirements tested per ASTM E 84.

1.5 DELIVERY, STORAGE, AND HANDLING

- A. Deliver wood acoustic panels and suspension system components to Project site in original, unopened packages and store them in a fully enclosed space where they will be protected against damage from moisture, direct sunlight, surface contamination, and other causes.
- B. Before installing wood acoustic panels, permit them to reach room temperature and a stabilized moisture content.
- C. Handle wood acoustic panels carefully to avoid chipping edges or damaging units in any way.

1.6 PROJECT CONDITIONS

- A. Environmental Limitations: Do not install wood acoustic panel ceilings until spaces are enclosed and weatherproof, wet-work in spaces is complete and dry, work above ceilings is complete, and ambient temperature and humidity conditions are maintained at the levels indicated for Project when occupied for its intended use.

1.7 COORDINATION

- A. Coordinate layout and installation of wood acoustic panels and suspension system with other construction that penetrates ceilings or walls or is supported by them, including light fixtures, HVAC equipment, fire-suppression system, and partition assemblies.

1.8 EXTRA MATERIALS

- A. Extra Materials: Furnished from same production run as acoustical ceiling panels installed. Furnish 5% of each type and color of material provided in the work. Package materials with protective covering and identify with labels describing contents. Deliver extra materials to Owner.

PART 2 - PRODUCTS

2.1 WOOD ACOUSTIC PANELS

- A. Perforated Wood Veneer Acoustic Panels: Wood veneer of the following species, cut and matching applied to a core material.

1. Wood Species and Cut for Transparent Finish: Grade A Select Maple, plain sawn/sliced.
2. Face Profile: 8/8/2 (Where the first two numbers describe the distance between holes vertically and horizontally and the third number describes the diameter of the perforation. Where two numbers are listed with a dash, the first number describes the rear hole and the second number describes the face hole.)
3. Rear Perforation: T-hole perforation - dual diameter holes on panel, smaller diameter hole at the face of the panel meeting the larger diameter hole at rear of panel. This option will serve to increase low frequency absorption performance.
4. Core: Class A fire rated medium density fiberboard (MDF) core (when tested according to ASTM E-84 procedures)
5. Panel Size: As indicated on Drawings.
6. Panel Edges: Edgebanding on all sides of panel.
7. Backing: Black, nonwoven glass fiber matt (60 g/m² density) shall be adhered to rear of panel.
8. Acoustic insulation to be included behind panels shall be 1" thick, 6 lb/ft³ density fiberglass
9. No edge molding required.
10. Cutouts factory completed with full finished edges at cut.
11. Finish: Factory finish with clear natural lacquer with matte finish.
12. Basis of Design Product: Topperfo 8/8/2T by Topakustik, or equal.

2.2 SUSPENSION SYSTEMS

- A. Suspension System: Full accessibility suspension grid system consisting of a primary U-profile grid member, a secondary Omega Profile, spring bar, and torsion springs to support the weight of the panels. The panel edge profile can be dictated by design and returns or trim are possible with this system as the panels are downwardly accessible. Attachment to structure is the responsibility of the installing contractor to meet all local codes and regulations. It is recommended that the attachment be achieved with a threaded rod supplied by the installing contractor.
1. Hardware included in this system consists of the U-profile main runner, Omega profile secondary runner with slots to accept springs, spring bar mounted to panels with custom profile to allow sliding of springs as necessary to fit Omega profile slots, torsion springs, special screws to attach hardware to rear perforations, transverse panel stiffening hardware, and any wall connection profiles required.
 2. Panels remove with a special tool provided with material that allows for a simple downward release of the spring from the grid. Panels can then be fully removed from the grid by pressing the springs to release from the Omega profile slot.
 3. Basis of Design Product: S-11 (Torsion Spring)
- B. Attachment Devices: Size for five times design load indicated in ASTM C 635, Table 1, Direct Hung, unless otherwise indicated.
1. Power-Actuated Fasteners in Concrete: Fastener system of type suitable for application indicated, fabricated from corrosion-resistant materials, with clips or other accessory devices for attaching hangers of type indicated, and with capability to sustain, without failure, a load equal to 10 times that imposed by ceiling

construction, as determined by testing per ASTM E 1190, conducted by a qualified testing and inspecting agency.

- C. Wire Hangers, Braces, and Ties: Provide wires complying with the following requirements:
 - 1. Zinc-Coated Carbon-Steel Wire: ASTM A 641/A 641M, Class 1 zinc coating, soft temper.
 - 2. Size: Select wire diameter so its stress at three times hanger design load (ASTM C 635, Table 1, Direct Hung) will be less than yield stress of wire, but provide not less than 0.106-inch- (2.69-mm-) diameter wire.

PART 3 - EXECUTION

3.1 EXAMINATION

- A. Examine substrates and structural framing to which wood acoustic panels and suspension systems attach or abut, with Installer present, for compliance with requirements specified in this and other Sections that affect ceiling installation and anchorage, and other conditions affecting performance of panel ceilings and walls.
- B. Proceed with installation only after unsatisfactory conditions have been corrected.

3.2 PREPARATION

- A. Coordination: Furnish layouts for cast-in-place anchors, clips, and other anchors whose installation is specified in other Sections.
- B. Measure each area and establish layout of panels to balance border widths at opposite edges of each ceiling or wall. Avoid using less-than-half-width panels at borders, and comply with layout shown on reflected ceiling plans and shop drawings.

3.3 CEILING INSTALLATION

- A. General: Install panel ceilings to comply with publications referenced below per manufacturer's written instructions and CISCA's "Ceiling Systems Handbook."
 - 1. Standard for Ceiling Suspension System Installations: Comply with ASTM C 636.
- B. Suspend ceiling hangers from building's structural members and as follows:
 - 1. Install hangers plumb and free from contact with insulation or other objects within ceiling plenum that are not part of supporting structure or of ceiling suspension system.
 - 2. Splay hangers only where required to miss obstructions; offset resulting horizontal forces by bracing, countersplaying, or other equally effective means.
 - 3. Where width of ducts and other construction within ceiling plenum produces hanger spacings that interfere with location of hangers at spacings required to support

- standard suspension system members, install supplemental suspension members and hangers in form of trapezes or equivalent devices. Size supplemental suspension members and hangers to support ceiling loads within performance limits established by referenced standards and publications.
4. Secure wire hangers to ceiling suspension members and to supports above with a minimum of three tight turns. Connect hangers directly either to structures or to inserts, eye screws, or other devices that are secure; that are appropriate for substrate; and that will not deteriorate or otherwise fail due to age, corrosion, or elevated temperatures.
 5. Do not attach hangers to steel deck tabs.
 6. Do not attach hangers to steel roof deck. Attach hangers to structural members.
 7. Space hangers not more than 48 inches (1200 mm) o.c. along each member supported directly from hangers, unless otherwise indicated; and provide hangers not more than 8 inches (200 mm) from ends of each member.
- C. Install edge moldings and trim of type indicated at perimeter of ceiling area and where necessary to conceal edges of panels.
- D. Install suspension system runners so they are square and securely interlocked with one another. Remove and replace dented, bent, or kinked members.
- E. Install panels with undamaged edges and fitted accurately into suspension system runners and edge moldings. Scribe and cut panels at borders and penetrations to provide a neat, precise fit.
1. Arrange directionally patterned panels as indicated on reflected ceiling plans.
 2. Install clips to attach panels to suspension system in conformance with manufacturer's directions..

3.4 CLEANING

- A. Clean exposed surfaces of wood acoustic panels, including trim, edge moldings, and suspension system members. Comply with manufacturer's written instructions for cleaning and touchup of minor finish damage. Remove and replace components that cannot be successfully cleaned and repaired to permanently eliminate evidence of damage.

END OF SECTION 095429

SECTION 096466 - WOOD ATHLETIC FLOORING

PART 1 - GENERAL

1.1 SUMMARY

- A. This Section includes the following:
 - 1. Solid-wood strip flooring.
 - 2. Subfloor panels with resilient pads and metal anchor channels.
 - 3. Vapor barrier.
 - 4. Finishing wood floors.
 - 5. Floor markings
 - 6. Ventilating wall base.

1.2 ACTION SUBMITTALS

- A. Product Data: For each type of product indicated.
- B. Shop Drawings: Show installation details including location and layout of each type of wood flooring and accessory. Include expansion provisions and trim details. Include scaled layout drawing of game line markings and locations of floor sleeves for equipment.
- C. Samples for Initial Selection: Manufacturer's color charts showing colors and glosses available for the following:
 - 1. Floor finish.
 - 2. Game line paint.
- D. Samples for Verification: For each type of wood flooring and accessory, with stain color and finish required, approximately 12 inches (300 mm) long and of same thickness and material indicated for the Work. Include sample sets showing the full range of normal color and texture variations expected.

1.3 INFORMATIONAL SUBMITTALS

- A. Qualification Data: for installer and manufacturer.
- B. Test Reports: Independent testing report showing the flooring system has passed all performance criteria.
- C. Maintenance instructions.

1.4 QUALITY ASSURANCE

- A. Installer Qualifications: An experienced installer who has completed wood athletic flooring systems similar in material, design, and extent to that indicated for this Project and is approved by the flooring manufacturer to install their flooring system.
- B. Manufacturer Qualifications: Manufacturer shall be a member in good standing of the Maple Flooring Manufacturers Association (MFMA).
- C. Source Limitations: Obtain each type of material and product from one source with resources to provide materials and products of consistent quality in appearance and physical properties.
- D. Maple Flooring: Comply with MFMA grading rules for grade and cut.
 - 1. Certification: Provide flooring that carries MFMA Certification Mark on each piece.
- E. Wood flooring system shall meet or exceed the following performance criteria:
 - 1. MFMA PUR
 - 2. DIN 18032 Part2 2001
 - 3. DIN 18032 Part2 1991
 - 4. ASTM F2772 Sport Floor Standards
 - 5. FIBA International Standards
 - 6. EN 14904 Standards

1.5 DELIVERY, STORAGE, AND HANDLING

- A. Deliver wood flooring materials in unopened cartons or bundles.
- B. Protect wood flooring from exposure to moisture. Do not deliver wood flooring until after concrete, masonry, plaster, ceramic tile, and similar wet-work is complete and dry.
- C. Store wood flooring materials in a dry, warm, well-ventilated, weathertight location.
- D. Move wood flooring into spaces where it will be installed, at least seven days before installation.

1.6 PROJECT CONDITIONS

- A. Conditioning: Maintain relative humidity of 35% to 50% and an ambient temperature between 55 and 80 deg F in spaces to receive wood flooring for at least seven days before installation, during installation, and for at least seven days after installation. After post-installation period, maintain relative humidity and ambient temperature planned for building occupants.
 - 1. For unfinished products, open sealed packages to allow wood flooring to acclimatize.
 - 2. Do not install flooring until it adjusts to the relative humidity of and is at the same temperature as the space where it is to be installed.

3. Close spaces to traffic during flooring installation and for time period after installation recommended in writing by flooring and finish manufacturers.
- B. Moisture Testing of Concrete Substrates: Perform moisture tests recommended by manufacturer and as follows:
1. Testing Procedures: Perform moisture meter tests as required by wood flooring manufacturers.
 - a. Moisture Meter Testing: Relative humidity test using in situ probes, ASTM F 2170.
 2. Proceed with installation only after substrates do not exceed maximum relative humidity level measurement acceptable to flooring material manufacturer.
- C. Do not install floor system until concrete has been cured 60 days, unless otherwise permitted by flooring manufacturer.

PART 2 - PRODUCTS

2.1 MANUFACTURERS

- A. Manufacturers: Provide Basis of Design system manufactured by Robbins Sport Surfaces or equal system by one of the following:
1. Action Floor Systems
 2. Conner Sports.

2.2 WOOD ATHLETIC FLOORING SYSTEM

- A. Basis of Design System: provide Robbins Bio-Channel Star floor system by Robbins, Inc. or equal. system consists of maple strip flooring, subflooring, resilient pads, and metal anchor channels.
- B. Maple Strip Flooring: Northern hard maple (*Acer saccharum*), kiln dried.
1. Grade: Second & Better.
 2. Cut: Flat grain.
 3. Type: Finger-jointed
 4. Lengths: Nominal 15 to 96 inches complying with MFMA grading rules, unless otherwise required for patterns indicated.
 5. Matching: Tongue and groove, side matched and end matched.
 6. Expansion Feature: XL Plus technology to reduce or eliminate routine spacing for expansion.
 7. Backs: Channeled (kerfed) for stress relief.
 8. Thickness: 25/32 inch
 9. Face Width: 2-1/4 inches.
 10. Basis of Design Product: Continuous Strip XLPLUS by Robbins, or equal.

- C. Subfloor/Underlayment: Premanufactured plywood panels factory prepared to receive anchor channels.
 - 1. Basis of Design Product: Bio-Channel Star by Robbins or equal.
- D. Resilient Pads: 9/16" Zero/G shock pad by Robbins.
- E. Metal anchor channels.

2.3 FINISHING MATERIALS

- A. Urethane Finish System: Complete system of compatible components that is recommended by finish manufacturer for application indicated.
 - 1. VOC Content: When calculated according to 40 CFR 59, Subpart D (EPA Method 24), as follows:
 - a. Finish Coats and Floor Sealers: Not more than 350 g/L.
 - 2. Type: Solvent-based, oil-modified.
 - 3. Floor Sealer: Pliable, penetrating type.
 - 4. Finish Coats: Formulated for multicoat application on wood flooring.
 - 5. Manufacturers: Provide products by flooring manufacturer or one of the following as approved by flooring manufacturer:
 - a. Bona Sport Poly; Bona.
 - b. DuraSeal Masterline Oil Polyurethane Gloss; Dura Seal.
 - c. 450 Gym Finish; Hillyard Floor Treatments.
- B. Wood Filler: Formulated to fill and repair seams, defects, and open-grain hardwood floors; compatible with finish system components and recommended by filler and finish manufacturers for use indicated. If required to match approved samples, provide pigmented filler.
- C. Game-Line and Marker Paint: High-gloss enamel compatible with finish and recommended by finish and paint manufacturers for this purpose.
 - 1. Colors: all colors as indicated on Drawings
 - a. 2 colors for game lines of basketball and volleyball.
 - b. 3 additional colors for Y logo

2.4 ACCESSORY MATERIALS

- A. Vapor Retarder: ASTM D 4397, polyethylene sheet not less than 6.0 mils (0.15 mm) thick.
- B. Fasteners and Adhesives: Type and size recommended by manufacturer, but not less than those recommended by the following:
 - 1. MFMA for application indicated for maple flooring.

2. Channel Anchors: Type recommended by flooring manufacturer.
- C. Wall Base: 6" high molded vented cove base with pre-molded outside corners, in color selected by Architect.
- D. Provide all accessories at door thresholds for a complete installation.

2.5 INSTALLATION ACCESSORIES

- A. Trowelable Underlayments and Patching Compounds: Latex-modified, portland-cement-based formulation provided or approved by flooring manufacturer for applications indicated.

PART 3 - EXECUTION

3.1 EXAMINATION

- A. Examine substrates, areas, and conditions, with Installer present, for compliance with requirements, installation tolerances, and other conditions affecting performance of wood flooring. Proceed with installation only after unsatisfactory conditions have been corrected.
- B. Concrete Slabs: Verify that concrete slabs comply with requirements specified Division 03 Section "Cast-in-Place Concrete."
 1. Grind high spots and fill low spots to provide a maximum 1/8-inch deviation in any direction when checked with a 10-foot straight edge.
 2. Use trowelable leveling and patching compounds per flooring manufacturer's directions to fill cracks, holes, and depressions in substrates and to patch and level floors as required to provide suitable substrate for flooring application.
- C. Concrete Moisture Testing: Perform moisture meter test as per manufacturer's directions and in accordance with ASTM F 2170, as follows:
 1. Perform tests so that each test area does not exceed 200 sq. ft. (18.6 sq. m) and perform not less than 2 tests in each installation area with test areas evenly spaced in installation area.
 2. Proceed with installation only after substrates have maximum relative humidity of 85% or less.

3.2 INSTALLATION

- A. General: Comply with flooring system manufacturer's written instructions, but not less than recommendations of MFMA applicable to flooring type indicated for maple flooring.
- B. Pattern: Lay flooring parallel with the long dimension of the space to be floored, unless otherwise indicated.

- C. Expansion Space: Provide expansion space at walls and other obstructions and terminations of flooring of not less than 2".
- D. Vapor Retarder: Install a layer of polyethylene sheet over concrete slab with edges overlapped minimum 6" and sealed, and turned up behind baseboards.
- E. Subfloor/Underlayment: Place subfloor assembly in end-to-end manner, staggering end joints in adjacent rows, with 1/4" gap between panels. Place panels on a 45 degree angle to the direction of the maple flooring. Install solid blocking under bleachers in the stacked position, at doorways and elsewhere as recommended by manufacturer.
- F. Anchor Channels: Place metal anchor channels in preformed slots in the subfloor panels., and anchor in pre-routed holes.
- G. Solid-Wood Strip and Plank Flooring: Install maple flooring parallel to main playing court by power nailing at intervals recommended by manufacturer. End joints shall be properly driven up. Provide spacing for humidity control as recommended by flooring manufacturer.
- H. Installation Tolerances: 1/8 inch in 10 feet variance from level.

3.3 SANDING AND FINISHING

- A. Machine-sand flooring to remove offsets, ridges, cups, and sanding-machine marks that would be noticeable after finishing. Vacuum and tack with a clean cloth immediately before applying finish.
- B. Apply filler according to manufacturer's written instructions.
 - 1. Fill open-grained hardwood.
 - 2. Fill and repair seams and defects.
- C. Apply floor sealer according to finish manufacturer's written instructions, in number of coats recommended by finish manufacturer.
- D. Apply floor finish according to finish manufacturer's written instructions. Apply in number of coats recommended by finish manufacturer for application indicated, but not less than two.
- E. Lines and Markers: After applying sealer coats, screening, and vacuuming of floor, lay out lines, fields and other markings as indicated for colored enamel application. Mask flooring to provide sharp edges. Apply gym enamel 1.0 mil thick, in colors as indicated. Where game lines cross, break minor game line at intersection; do not overlap lines.
 - 1. For game markings, use current rules of the National Federation of High School Association or other association having jurisdiction.
- F. Install base trim and other cover trim as indicated for expansion spaces at edges and interruptions of flooring. Cement or screw to walls.

3.4 PROTECTION

- A. Cover installed wood flooring to protect it from damage or deterioration, before and after finishing, during remainder of construction period. Use heavy kraft-paper or other suitable covering. Do not use plastic sheet or film that could cause condensation.
 - 1. Do not cover site-finished floors with kraft paper, or any other material, until finish reaches full cure, but not less than seven days after applying last coat.

END OF SECTION 096466

SECTION 096500 - RESILIENT FLOORING AND ACCESSORIES

PART 1 - GENERAL

1.1 SUMMARY

A. This Section includes the following:

1. Homogeneous sheet vinyl flooring.
2. Luxury vinyl tile
3. Rubber floor tile
4. Rubber wall base.
5. Stair accessories.
6. Resilient flooring accessories.

B. Related Work Specified Elsewhere:

1. Ventilating cove base for wood athletic flooring is specified in Division 09 Section "Wood Athletic Flooring."

1.2 ACTION SUBMITTALS

A. Product data for each type of product specified.

B. Samples for verification purposes in form of actual flooring or sections of accessories for each color and pattern specified.

1. For heat-welding bead, manufacturer's standard-size samples, but not less than 9 inches (230 mm) long, of each color specified.

C. Shop Drawings: Indicate decorative pattern layout, if any. Show location of seams and edges. Indicate location of columns, doorways, enclosing partitions, built-in furniture, cabinets, and cutout locations.

1.3 INFORMATIONAL SUBMITTALS

A. Maintenance data for resilient flooring and accessories.

1.4 QUALITY ASSURANCE

A. Installer Qualifications: Engage an installer who is competent in the technique required by sheet flooring manufacturer for heat-welding seams.

B. Single-Source Responsibility for Floor Tile and Accessories: Obtain each type, color, and pattern of tile and accessory from a single source; all stair accessories shall be from one manufacturer.

- C. Single-Source Responsibility for Sheet Flooring and Accessories: Obtain each type, color, and pattern of sheet floor covering specified from one source with resources to provide products of consistent quality in appearance and physical properties without delaying the Work.
- D. Fire Performance Characteristics: Provide resilient flooring with the following fire performance characteristics as determined by testing products per test method indicated below by UL or another testing and inspecting agency acceptable to authorities having jurisdiction.
 - 1. Critical Radiant Flux: 0.45 watts per sq. cm or more, Class 1, per ASTM E 648 or NFPA 253.

1.5 DELIVERY, STORAGE, AND HANDLING

- A. Store resilient materials on flat surface in dry space protected from the weather with ambient temperatures maintained between 50 deg F (10 deg C) and 90 deg F (32 deg C).
- B. Store rolls of sheet flooring upright.
- C. Move floor coverings and installation accessories into spaces where they will be installed at least 48 hours before installation, unless longer conditioning periods are recommended in writing by manufacturer.

1.6 PROJECT CONDITIONS

- A. Maintain a minimum temperature of 70 deg F (21 deg C) in spaces to receive resilient flooring for at least 72 hours prior to installation, during installation, and for not less than 72 hours after installation. After this period, maintain a temperature of not less than 55 deg F (13 deg C).
- B. Moisture Testing of Concrete Substrates: Perform moisture tests recommended by manufacturer and as follows:
 - 1. Testing Procedures: Perform calcium chloride or moisture meter tests as required by floor topping and resilient tile manufacturers.
 - a. Calcium Chloride Testing: Anhydrous calcium chloride test, ASTM F 1869.
 - b. Moisture Meter Testing: Relative humidity test using in situ probes, ASTM F 2170.
 - 2. Proceed with installation only after substrates do not exceed maximum moisture-vapor-emission rate or relative humidity level measurement acceptable to flooring material manufacturer.
- C. Do not install flooring or accessories until they are at the same temperature as the space where they are to be installed.
- D. Close spaces to traffic during flooring installation.

1.7 SEQUENCING AND SCHEDULING

- A. Install flooring and accessories after other finishing operations, including painting, have been completed.

1.8 EXTRA MATERIALS

- A. Extra Materials: Furnished from same production run as resilient tile, base and accessories installed. Furnish 5% of each type and color of material provided in the work. Package materials with protective covering and identify with labels describing contents. Deliver extra materials to Owner.

- 1. Extra materials of sheet floor covering is not required.

PART 2 - PRODUCTS

2.1 MANUFACTURERS

- A. Available Manufacturers: Subject to compliance with requirements, manufacturers offering products which may be incorporated in the Work include, but are not limited to, the following:

- 1. Tiles and Sheet:
 - a. Armstrong World Industries
 - b. Mannington
 - c. Mohawk Group
 - d. Patcraft
 - e. Shaw Hard Surface
 - f. Tarkett
- 2. Base and Other Accessories:
 - a. Armstrong
 - b. Endura
 - c. Roppe
 - d. Johnsonite
- 3. Rubber Landing Tiles and Stair Treads:
 - a. Endura Large Tile
 - b. Nora
 - c. Johnsonite
 - d. Roppe

2.2 PRODUCTS, GENERAL

- A. Colors, Textures, and Patterns: Provide tile, sheet goods and accessories in color, texture and pattern to match specified products. Colors and patterns indicated by reference to manufacturer's name and designations are for color and pattern identification only and are not intended to limit selection of other manufacturer's products with similar

colors and patterns. If no colors or patterns are indicated, provide color(s) and pattern(s) as selected by Architect from manufacturer's standards.

- B. Resilient flooring and base shall comply with RFCI FloorScore Program.

2.3 RESILIENT TILE FLOORING

- A. Luxury Vinyl Tile LVT1: Luxury vinyl tile complying with ASTM F1700, Class III, Type B and as follows:

1. Basis of Design Product: Tarkett Color Play Collection, Color Beam pattern, or equal.
2. Size: 18" x 18"
3. Wear Layer Thickness: 32 mil
4. Total thickness: 0.120"
5. Finish: Emboss - Quarry
6. Surface Treatment: Techtonic
7. Warranty: 25 years.
8. Color: Manta Grey C114.
9. Installation: Monolithic.
10. Location: Classrooms field tile.

- B. Luxury Vinyl Tile LVT2: Luxury vinyl tile complying with ASTM F1700, Class III, Type B and as follows:

1. Basis of Design Product: Tarkett Riot Static, or equal.
2. Size: 18" x 18"
3. Wear Layer Thickness: 32 mil
4. Total thickness: 0.120"
5. Surface Treatment: Techtonic
6. Warranty: 25 years.
7. Color: Sun 10122QU.
8. Installation: Quarter turned.
9. Location: First Floor Classrooms accent tile.

- C. Luxury Vinyl Tile LVT3: Luxury vinyl tile complying with ASTM F1700, Class III, Type B and as follows:

1. Basis of Design Product: Tarkett Riot Static, or equal.
2. Size: 18" x 18"
3. Wear Layer Thickness: 32 mil
4. Total thickness: 0.120"
5. Surface Treatment: Techtonic
6. Warranty: 25 years.
7. Color: Lime 10121QU.
8. Installation: Quarter turned.
9. Location: Second Floor Classrooms accent tile.

- D. Luxury Vinyl Tile LVT4: Luxury vinyl tile complying with ASTM F1700, Class III, Type B and as follows:
1. Basis of Design Product: Tarkett Static, or equal.
 2. Size: 18" x 18"
 3. Wear Layer Thickness: 32 mil
 4. Total thickness: 0.120"
 5. Surface Treatment: Techtonic
 6. Warranty: 25 years.
 7. Color: Cyan 10112QU.
 8. Installation: Quarter turned.
 9. Location: Third Floor Classrooms accent tile.
- E. Luxury Vinyl Tile LVT5: Luxury vinyl tile complying with ASTM F1700, Class III, Type B and as follows:
1. Basis of Design Product: Tarkett Static, or equal.
 2. Size: 18" x 18"
 3. Wear Layer Thickness: 32 mil
 4. Total thickness: 0.120"
 5. Surface Treatment: Techtonic
 6. Warranty: 25 years.
 7. Color: Dark 10116QU.
 8. Installation: Quarter turned.
 9. Location: Fourth Floor Classrooms accent tile.
- F. Luxury Vinyl Tile LVT6: Luxury vinyl tile complying with ASTM F1700, Class III, Type B and as follows:
1. Basis of Design Product: Patcraft Mark Making I509V, or equal.
 2. Size: 6" x 48"
 3. Wear Layer Thickness: 20 mil
 4. Total thickness: 0.197"
 5. Finish: Exoguard+
 6. Color: Pure 00500.
 7. Installation: Staggered.
 8. Location: Learning Commons field color.
- G. Luxury Vinyl Tile LVT7: Luxury vinyl tile complying with ASTM F1700, Class III, Type B and as follows:
1. Basis of Design Product: Patcraft Mark Making I509V, or equal.
 2. Size: 6" x 48"
 3. Wear Layer Thickness: 20 mil
 4. Total thickness: 0.197"
 5. Finish: Exoguard+
 6. Color: Bliss 00250.
 7. Installation: Staggered.
 8. Location: Learning Commons accent color

- H. Luxury Vinyl Tile LVT8: Luxury vinyl tile complying with ASTM F1700, Class III, Type B and as follows:
1. Basis of Design Product: Patcraft Mark Making I509V, or equal.
 2. Size: 6" x 48"
 3. Wear Layer Thickness: 20 mil
 4. Total thickness: 0.197"
 5. Finish: Exoguard+
 6. Color: Watercolor 00400.
 7. Installation: Staggered.
 8. Location: Learning Commons accent color
- I. Luxury Vinyl Tile LVT9: Luxury vinyl tile complying with ASTM F1700, Class III, Type B and as follows:
1. Basis of Design Product: Tarkett Contour collection, Modern Stone pattern, or equal.
 2. Size: 18" x 18"
 3. Wear Layer Thickness: 1 mil
 4. Total thickness: 0.120"
 5. Surface Treatment: Techtonic
 6. Warranty: 25 years.
 7. Color: Rialto PCMS0631QU.
 8. Installation: Quarter turned.
 9. Location: Makerspace and Art Room field.
- J. Luxury Vinyl Tile LVT10: Luxury vinyl tile complying with ASTM F1700, Class III, Type B and as follows:
1. Basis of Design Product: Tarkett Contour collection, Modern Wood pattern, or equal.
 2. Size: 6" x 48"
 3. Wear Layer Thickness: 1 mil
 4. Total thickness: 0.120"
 5. Surface Treatment: Techtonic
 6. Warranty: 25 years.
 7. Color: Canadian Maple PCMD3306NG.
 8. Installation: Plank.
 9. Location: Health suite, Faculty Lounge
- K. Luxury Vinyl Tile LVT11: Luxury vinyl tile complying with ASTM F1700, Class III, Type B and as follows:
1. Basis of Design Product: Tarkett Static, or equal.
 2. Size: 18" x 18"
 3. Wear Layer Thickness: 32 mil
 4. Total thickness: 0.120"
 5. Surface Treatment: Techtonic

6. Warranty: 25 years.
7. Color: Mottle 10016.
8. Installation: Quarter turned.
9. Location: Art Room accent tile.

L. Rubber Floor Tile RF: Rubber floor tile complying with ASTM F1344, and as follows:

1. Basis of Design Product: Norament Grano.
2. Size: 39.53" x 39.53"
3. Tile Thickness: 0.14
4. Colors:
 - a. RF-1: 5317 Agapanthus
 - b. RF-2: 5302 Angelica Road
5. Installation: Monolithic
6. Location: OT room.

2.4 RESILIENT SHEET FLOORING

A. Homogeneous Sheet Vinyl Flooring VSF: High performance homogeneous sheet vinyl flooring

1. Basis of Design Product: Tarkett Melodia collection, Melodia 3.0 pattern.
2. Roll Width: 6.5 ft.
3. Wear Layer Thickness: 0.080" (2mm)
4. Total Thickness: 0.080" (2mm)
5. Surface Treatment: Polyurethane - Reinforced, meeting ASTM F410
6. Color: Mariblu 0979.
7. Location: Health Suite
8. Accessories: Provide blue welding rod.

2.5 RESILIENT WALL BASE

A. Rubber Wall Base: ASTM F 1861, Type TP, Group 1 (solid), 4" high, 1/8" thick, smooth surface, and as follows:

1. Style: Straight (toeless) style for all carpeted areas and cove base with toe (set-on type) elsewhere
2. Lengths: Coils in manufacturer's standard length.
3. Inside and Outside Corners: Preformed.
4. Products: Rubber Base by Johnsonite/Tarkett.
5. Colors: As selected by Architect.

B. Homogeneous Sheet Vinyl Cove Base: Provide integral flash cove wall base using sheet flooring.

2.6 RESILIENT STAIR ACCESSORIES

A. Stair Treads and Risers : Rubber one-piece tread/riser combination meeting ASTM F-2169, Type TS, Class 2, Group 1 and/or 2, Grade 2 and as follows:

1. Nosing Style: Square, hinged.
2. Thickness: 0.20 inches
3. Depth: 19.88 inches.
4. Height: 1.77 inches.
5. Length: As required to fit each stair tread in one piece.
6. Surface Texture: Hammered.
7. Solid Rubber Colored Insert Strip: 2" wide, in contrasting color for visually-impaired.
 - a. Insert Strip Color: Nora 0985.
8. Basis of Design Products and Colors:
 - a. Stair A and C: Norament Grano by Nora, in the following colors:
 - 1) Stair A: 5325 Balsam
 - 2) Stair C: 5318 Blue Tansy.
 - b. Stair B and All Other Stairs (except Cafeteria): Norament Satura by Nora in color 5121 Hydra.

B. Rubber Tile at Stair Landings: Rubber tile matching tread/riser units for each location.

1. Tile Size: 39.53" x 39.53"
2. Tile Thickness: 0.14"
3. Basis of Design Products: Norament Grano and Satura by Nora.
4. Colors: Match adjacent tread/riser units.

2.7 MISCELLANEOUS RESILIENT ACCESSORIES

- A. Colors: As selected by Architect from manufacturer's full range of colors produced for accessory molding complying with requirements indicated.
- B. Rubber Accessory Moldings: Provide rubber accessory molding complying with the following:
 1. Product Description: Carpet edge for glue-down applications, carpet nosing, reducer strip for resilient flooring, and tile and carpet joiner.
 - a. Provide rubber transition strip at resilient floor tile color changes - at doors.
 2. Profile and Dimensions: As indicated or required.
- C. Heat-Welding Bead: Solid-strand product of floor covering manufacturer for heat-welding seams.
 1. Color and Pattern: Match color and pattern of sheet floor covering.
- D. Metal Accessories for Homogeneous Sheet Wall Base:
 1. Tarkett Covecap CCC-XX-C in color and pattern matching sheet floor covering.

2.8 INSTALLATION ACCESSORIES

- A. Concrete Slab Primer: Nonstaining type as recommended by flooring manufacturer.
- B. Concrete Sealer: Type recommended and approved by resilient flooring manufacturer and adhesive manufacturer to ensure proper adhesion of resilient flooring to substrate.
- C. Trowelable Underlayments and Patching Compounds: Latex-modified, portland-cement-based formulation provided or approved by flooring manufacturer for applications indicated.
- D. Adhesives (Cements): Products supplied by resilient flooring and accessory manufacturers, of type recommended to suit resilient products and substrate conditions.
- E. Heat-Welding Bead: Solid-strand product of floor covering manufacturer for heat-welding seams.
 - 1. Color and Pattern: Match color and pattern of sheet floor covering.
- F. Floor Polish: Acrylic type, as recommended by flooring material manufacturer.

PART 3 - EXECUTION

3.1 EXAMINATION

- A. General: Examine areas where installation of flooring will occur, with Installer present, to verify that substrates and conditions are satisfactory for flooring installation and comply with flooring manufacturer's requirements and those specified in this Section.
- B. Concrete Subfloors: Verify that concrete slabs comply with ASTM F 710 and the following:
 - 1. Slab substrates are dry and free of curing compounds, sealers, hardeners, and other materials whose presence would interfere with bonding of adhesive. Determine adhesion and dryness characteristics by performing bond tests recommended by flooring manufacturer.
 - 2. Finishes of subfloors comply with tolerances and other requirements specified in Division 03 Section "Cast-In-Place Concrete" for slabs receiving resilient flooring.
 - 3. Subfloors are free of cracks, ridges, depressions, scale, and foreign deposits of any kind.
- C. Concrete Moisture Emission Tests: Perform calcium chloride test and moisture meter test as per manufacturer's directions, as follows, and other tests if recommended by resilient flooring and adhesive manufacturer:
 - 1. Perform moisture test at rate of one per 2,000 sq.ft. of new and existing floor area to be covered.
 - 2. Report test results in writing to Architect, and Contractor within 24 hours after tests are completed. Reports of concrete moisture emission tests shall contain the Project identification name and number, date of test location of test within structure.

3. Perform additional moisture emission tests of in-place concrete when test results indicate specified moisture content has been exceeded, as directed by Architect.
 - a. Repeat test one week after initial test minimally and additionally repeat test if required by field conditions to determine moisture levels in area of resilient flooring application.

- D. Do not proceed with installation until unsatisfactory conditions have been corrected.
- E. Only if it is not possible to provide a concrete substrate with acceptable moisture levels, then a surface applied moisture mitigation system shall be used that meets the requirements of ASTM F3010 Standard Practice for Two-Component Resin Based Membrane-Forming Moisture Mitigation Systems for Use Under Resilient Floor Coverings.

3.2 PREPARATION

- A. General: Comply with manufacturer's installation specifications to prepare substrates indicated to receive flooring.
- B. Use trowelable leveling and patching compounds per flooring manufacturer's directions to fill cracks, holes, and depressions in substrates and to patch and level floors as required to provide suitable substrate for flooring application.
- C. Remove coatings, including curing compounds, and other substances that are incompatible with flooring adhesives by using a grinder, sander, or polishing machine with a heavy-duty wire brush.
- D. Broom or vacuum clean substrates to be covered by flooring immediately before installation of flooring. Following cleaning, examine substrates for moisture, alkaline salts, carbonation, or dust.
- E. Apply concrete slab primer, if recommended by flooring manufacturer, prior to applying adhesive. Apply according to manufacturer's directions.
- F. Seal concrete substrates as required by moisture test results to ensure proper adhesion of resilient flooring to substrate.

3.3 SHEET FLOORING INSTALLATION

- A. General: Comply with sheet floor covering manufacturer's written installation instructions.
- B. Unroll sheet floor coverings and allow them to stabilize before cutting and fitting, if recommended in writing by manufacturer.
- C. Lay out sheet floor coverings to comply with the following requirements:
 1. Maintain uniformity of sheet floor covering direction.
 2. Arrange for a minimum number of seams and place them in inconspicuous and low-traffic areas, and not less than 6 inches (150 mm) away from parallel joints in flooring substrates.

3. Match edges of sheet floor coverings for color shading and pattern at seams according to manufacturer's written recommendations.
 4. Avoid cross seams.
- D. Scribe, cut, and fit sheet floor coverings to butt neatly and tightly to vertical surfaces and permanent fixtures, including built-in furniture, cabinets, pipes, outlets, edgings, door frames, thresholds, and nosings.
 - E. Extend sheet floor coverings into toe spaces, door reveals, closets, and similar openings.
 - F. Maintain reference markers, holes, and openings that are in place or marked for future cutting by repeating on finish flooring as marked on subfloor. Use chalk or other nonpermanent, nonstaining marking device.
 - G. Install sheet floor coverings on covers for telephone and electrical ducts, and similar items in finished floor areas. Maintain overall continuity of color and pattern with pieces of flooring installed on covers. Tightly adhere edges to perimeter of floor around covers and to covers.
 - H. Adhere sheet floor coverings to flooring substrates to comply with floor covering manufacturer's written instructions, including those for trowel notching, adhesive mixing, and adhesive open and working times.
 1. Produce completed installation without open cracks, voids, raising and puckering at joints, telegraphing of adhesive spreader marks, and other surface imperfections.
 - I. Heat-Welded Seams: Rout joints and heat weld with welding bead, permanently fusing sections into a seamless floor covering. Prepare, weld, and finish seams according to manufacturer's written instructions and ASTM F 1516 to produce surfaces flush with adjoining floor covering surfaces.
 - J. Hand roll sheet floor coverings in both directions from center out to embed floor coverings in adhesive and eliminate trapped air. At walls, door casings, and other locations where access by roller is impractical, press floor coverings firmly in place with flat-bladed instrument.

3.4 TILE INSTALLATION

- A. General: Comply with tile manufacturer's installation directions and other requirements indicated that are applicable to each type of tile installation included in Project.
- B. Lay out tiles from center marks established with principal walls so tiles at opposite edges of room are of equal width. Install tiles square with room axis, unless otherwise indicated.
- C. Match tiles for color and pattern by selecting tiles from cartons in same sequence as manufactured and packaged, if so numbered. Cut tiles neatly around all fixtures. Discard broken, cracked, chipped, or deformed tiles.
 1. Lay tiles in decorative patterns as indicated on Drawings.

- D. Scribe, cut, and fit tiles to butt tightly to vertical surfaces and edgings.
- E. Extend tiles into toe spaces, door reveals, closets, and similar openings.
- F. Maintain reference markers, holes, and openings that are in place or marked for future cutting by repeating on finish flooring as marked on subfloor. Use chalk or other nonpermanent, nonstaining marking device.
- G. Install tiles on covers for telephone and electrical ducts, and similar items in finished floor areas. Maintain overall continuity of color and pattern with pieces of flooring installed on covers. Tightly adhere edges to perimeter of floor around covers and to covers.
- H. Adhere tiles to flooring substrates without producing open cracks, voids, raising and puckering at joints, telegraphing of adhesive spreader marks, or other surface imperfections in completed tile installation.
- I. Use full spread of adhesive applied to substrate in compliance with tile manufacturer's directions including those for trowel notching, adhesive mixing, and adhesive open and working times.
- J. Hand roll tiles where required by tile manufacturer.

3.5 INSTALLATION OF WALL BASE AND ACCESSORIES

- A. General: Install resilient accessories according to manufacturer's written installation instructions.
- B. Provide integral flash cove wall base by extending homogeneous sheet vinyl flooring 4 in. up the wall using adhesive, welding rod, and accessories recommended and approved by the flooring manufacturer. Install metal cap at top of base.
- C. Apply resilient wall base to walls, pilasters, casework, and other permanent fixtures in rooms and areas where base is required. Install wall base in lengths as long as practicable. Tightly adhere wall base to substrate throughout length of each piece, with base in continuous contact with horizontal and vertical substrates.
 - 1. On masonry surfaces or other similar irregular substrates, fill voids along top edge of resilient wall base with manufacturer's recommended adhesive filler material.
 - 2. Install preformed corners as per manufacturer's directions.
- D. Place resilient accessories so they are butted to adjacent materials of type indicated and bond to substrates with adhesive. Install reducer strips at edges of flooring that otherwise would be exposed.

3.6 INSTALLATION OF RESILIENT STAIR TREADS/RISERS

- A. Apply resilient treads/risers to stairs as indicated and according to manufacturer's written installation instructions.

- B. Use stair-tread-nose filler, according to resilient tread manufacturer's written instructions, to fill nosing substrates that do not conform to tread contours.

3.7 CLEANING AND PROTECTION

- A. Perform the following operations immediately after completing installation:
 - 1. Remove visible adhesive and other surface blemishes using cleaner recommended by manufacturers.
 - 2. Sweep or vacuum floor thoroughly.
 - 3. Do not wash floor until after time period recommended by resilient flooring manufacturer.
 - 4. Damp-mop flooring to remove black marks and soil.
- B. Protect flooring against mars, marks, indentations, and other damage from construction operations and placement of equipment and fixtures during remainder of construction period. Use protection methods indicated or recommended by flooring manufacturer.
 - 1. Apply protective floor polish to flooring surfaces that are free from soil, visible adhesive, and surface blemishes. Coordinate selection of floor polish with Owner's maintenance service requirements.
 - 2. Cover flooring with undyed, untreated building paper until inspection for Substantial Completion.
- C. Clean flooring not more than 4 days prior to dates scheduled for inspections intended to establish date of Substantial Completion in each area of Project. Clean flooring using method recommended by manufacturer.
 - 1. Strip protective floor polish that was applied after completing installation prior to cleaning.
 - 2. Reapply floor polish after cleaning.

END OF SECTION 096500

The following additions, substitutions, or clarifications are extracted from the (5) Bid Addenda issued with this project during bidding. This insert is intended to summarize addendum information relevant to this specification section. See Bid Addenda issued by the City of Yonkers for complete contract document changes.

Bid Addendum No. 4:

2.4 Logos- The extent of “artwork” for the logo is shown on the bid drawings. If additional artwork is required for fabrication the contractor will be required to include graphic services in their bid.

2.5 Precast Epoxy terrazzo Item B.4a- Base terrazzo in the multiuser toilet rooms is to match the adjacent terrazzo, not tile flooring as indicated.

This project is a poured terrazzo flooring project and is clearly specified, terrazzo tile is not equal and will not be considered.

SECTION 096623 - RESINOUS MATRIX TERRAZZO FLOORING

PART 1 - GENERAL

1.1 SUMMARY

A. This Section includes the following:

1. Epoxy-resin, thin-set terrazzo with integral wall base.
2. Thin-set, precast epoxy terrazzo coved base.
3. Thin-set, precast terrazzo thresholds.
4. Precast epoxy terrazzo stair treads and risers.
5. Precast epoxy terrazzo cladding for seating platforms in Cafeteria
6. Epoxy-resin, thin-set terrazzo logo
7. Crack suppression/isolation membrane.

B. Related Work Specified Elsewhere:

1. Division 03 Section "Cast-in-Place Concrete" for concrete substrate requirements.

1.2 ACTION SUBMITTALS

A. Product Data: For each type of terrazzo, component material, and accessory specified.

B. Shop Drawings: Include terrazzo fabrication and installation requirements. Include plans, elevations, sections, component details, and attachments to other Work. Show layout of the following:

1. Divider and control- and expansion-joint strips.
2. Base and border strips.
3. Precast terrazzo jointing and edge configurations.
4. Terrazzo patterns and logos.
5. Treads and risers on metal stair substrate.
6. Abrasive strip placement.
7. Crack suppression/isolation membrane placement.

C. Samples for Verification: Maximum of three 6-inch- (150-mm-) minimum square samples of each precast and cast-in-place terrazzo color and type required, showing the full range of color, texture, and pattern variations expected. Prepare samples of the same thickness and from the same material to be used for the Work. Provide minimum 6-inch- (150-mm-) long samples of each exposed strip item required.

1. Provide up to three sets of samples for verification of color for epoxy terrazzo flooring and precast units, as required to obtain Architect's approval.

1.3 INFORMATIONAL SUBMITTALS

- A. Qualification Data: For firms and persons specified in the "Quality Assurance" Article to demonstrate their capabilities and experience. Include lists of completed projects with project names and addresses, names and addresses of architects and owners, and other information specified.
- B. Material Certificates: Certificates signed by suppliers or manufacturers certifying that each material complies with requirements.
- C. Maintenance Data: Submit two copies of maintenance recommendations of NTMA or maintenance product members of NTMA.

1.4 QUALITY ASSURANCE

- A. Installer Qualifications:
 - 1. Installer shall be a contractor member of NTMA and shall perform all work in accordance with NTMA standards.
 - 2. Installer not a contractor member of NTMA shall have 10 years experience, completed terrazzo installations similar in material, design, and extent to that indicated for this Project, and shall submit a record of successful in-service performance.
 - 3. Installer shall have successfully completed a minimum of 5 projects involving custom designed logos installed in terrazzo flooring.
- B. Source Limitations: Obtain primary terrazzo materials through one source from a single manufacturer. Provide secondary materials including patching and fill material, joint sealant, and repair materials of type and from source recommended by manufacturer of primary materials.
- C. Source Limitations for Marble: Obtain each color, grade, type, and variety of marble from one source with resources to provide materials of consistent quality in appearance and physical properties without delaying the Work.
- D. NTMA Standards: Comply with the National Terrazzo and Mosaic Association's (NTMA) Guide Specification and written recommendations for terrazzo type indicated, unless more stringent requirements are specified.
- E. Mockups: Before installing terrazzo, construct mockups for each type and color required to verify selections made under Sample submittals and to demonstrate aesthetic effects and qualities of materials and execution. Build mockups to comply with the following requirements, using materials indicated for completed Work.
 - 1. Locate mockups in the location and of the size indicated or, if not indicated, as directed by Architect.
 - 2. Include integral base with poured-in-place floor.

3. Notify Architect 7 days in advance of dates and times when mockups will be constructed.
4. Demonstrate the proposed range of aesthetic effects and workmanship.
5. Obtain Architect's approval of mockups before proceeding with terrazzo installation.
6. Maintain mockups during construction in an undisturbed condition as a standard for judging the completed Work.
7. Approved mockups in an undisturbed condition at the time of Substantial Completion may become part of the completed Work.

F. Preinstallation Conference: Conduct conference at Project site to comply with requirements of Division 01 Section "Project Meetings." Review methods and procedures related to installation including, but not limited to, the following:

1. Inspect and discuss condition of substrate and preparatory work required to be performed.
2. Review and finalize construction schedule and verify availability of materials, Installer's personnel, equipment, and facilities needed to make progress and avoid delays.
3. Review dust-control procedures.

1.5 DELIVERY, STORAGE, AND HANDLING

- A. Deliver materials to Project site in suppliers' original wrappings and containers, labeled with source's or manufacturer's name, material or product brand name, and lot number, if any. Deliver materials in a manner to prevent damage to containers and/or bags.
- B. Store materials in their original, undamaged packages and containers, inside a well-ventilated area protected from weather, moisture, soiling, extreme temperatures, and humidity. Storage area temperature to be between 50 deg F (10 deg C) and 90 deg F (32 deg C).

1.6 PROJECT CONDITIONS

- A. Environmental Limitations: Maintain temperature above 50 deg F (10 deg C) for 72 hours before and during terrazzo installation. The minimum slab temperature for crack suppression system must be conditioned to 60°F before commencing installation, during installation, and for at least 72 hours after installation is complete.
- B. Do not install flooring if subfloor moisture emission rate exceeds indicated amounts when tested by calcium chloride moisture test or relative humidity test, with subfloor temperatures not less than 55 deg F.
 1. Calcium Chloride Moisture Test: Not more than 3 lb/1000 sq. ft./24 hours when tested according to ASTM F1869 using anhydrous calcium chloride.
 2. Relative Humidity Test: Maximum 75 percent relative humidity measurement when tested according to ASTM F2170 using in-situ probes.

- C. Control and collect dust produced by grinding operations. Protect adjacent construction from detrimental effects of grinding operations.
 - 1. Provide dustproof partitions and temporary enclosures to limit dust and migration and to separate areas from noise.

PART 2 - PRODUCTS

2.1 MANUFACTURERS

- A. Manufacturers: Subject to compliance with requirements, provide one of the following systems or equal:
 - 1. Crossfield Products Corp., Dex-O-Tex Division; Cheminert Terrazzo
 - 2. General Polymers Corporation, a Sherwin Williams Company; Thin-Set Epoxy Terrazzo #1100.
 - 3. Concord Terrazzo Company, Inc.; TERRAZZCO Groutless™ EZPour Epoxy 158
 - 4. Key Resin Company; Key Epoxy Terrazzo #108.
 - 5. Terrazzo & Marble Supply Companies; Terroxy Resin Systems Epoxy Matrix

2.2 MATERIALS

- A. Water: Potable.
- B. Marble Chips: Sizes conforming to NTMA gradation standards for mix and thickness indicated, with Ha 10 minimum abrasive-hardness value when tested according to ASTM C 241, 0.75 percent maximum 24-hour absorption rate, dust content of less than 1 percent by weight, and containing no deleterious or foreign matter. Colors as required to match Architect approved samples.
- C. Other Aggregates: One-sided mirror fragments or glass, as required.
- D. Epoxy-Resin Matrix: Provide matrix complying with NTMA's "Guide Specification for Epoxy Terrazzo" in color required for mix indicated.
 - 1. Shore Hardness at 24 Hours: 85/65 at 24 hours, when tested per ASTM D 2240.
 - 2. 100% concrete failure minimum, with 350 psi minimum tensile strength.
 - 3. Compressive Strength: Minimum of 11,000 psi when tested per ASTM D 695.
 - 4. Tensile Strength: Minimum of 6,000 psi when tested per ASTM D 638.
 - 5. Flexural Strength: Minimum of 10,000 psi when tested per ASTM D 790.
 - 6. Flammability: Self-extinguishing over concrete, tested per ASTM D 635.
 - 7. Abrasion Resistance: 70-90 milligrams lost when tested per ASTM D 4060.
- E. Thin-Set Divider Strips: Angle or T type, 3/8 inch (9.5 mm) deep, and as follows:
 - 1. Material: White zinc alloy.

2. Top Width: 1/8 inch (3.2 mm).
 3. Thickness: 16 gage.
- F. Control-Joint/Expansion Joint Strips: T-type strips with neoprene expansion insert matching material, thickness, and color of divider strips in depth required for topping thickness indicated.
1. Top Width: 1/8 inch (3.2 mm).
- G. Accessory Strips: Match divider-strip width, material, and color, unless otherwise indicated. Use the following types of accessory strips as required to provide a complete installation:
1. Edge beads for exposed edges of terrazzo.
 2. Base-bead strips for exposed top edge of terrazzo base.
- H. Patching and Fill Material for Epoxy Terrazzo: Resinous product of or approved by terrazzo manufacturer and recommended by manufacturer for application indicated.
- I. Joint Sealants: Recommended by terrazzo and sealant manufacturers and complying with requirements in Division 07 Section "Joint Sealants"
- J. Moisture-Vapor-Emission-Control Membrane: Two-component, high-solids, high-density, low-odor, epoxy-based membrane-forming product produced by epoxy terrazzo manufacturer that reduces moisture emission from concrete substrate to not more than 3 lb of water/1000 sq. ft. in 24 hours.
- K. Crack Suppression/Isolation Membrane: As recommended, produced and supplied by approved terrazzo resin formulator, having minimum 120 percent elongation potential per ASTM D 412.
1. Reinforcement: Fiberglass scrim, as required.
- L. Divider-Strip Adhesive: Epoxy-resin adhesive recommended by manufacturer for this use and acceptable to thin-set terrazzo resin manufacturer.
- M. Thin-Set Terrazzo Primer: Two-component resin or other compound recommended by thin-set terrazzo resin manufacturer for priming substrate.
- N. Thin-Set Terrazzo Finishing Grout: Thin-set terrazzo resin manufacturer's resin-based finishing grout.
- O. Cleaner: Chemically neutral cleaner with pH factor between 7 and 10 that is biodegradable, phosphate free, and recommended by cleaner manufacturer for use on terrazzo type indicated.
- P. Sealer: Slip- and stain-resistant, penetrating-type sealer that is chemically neutral with pH factor between 7 and 10, does not affect color or physical properties of terrazzo type

indicated, is recommended by sealer manufacturer for this use, and complies with NTMA Guide Specification for terrazzo type indicated.

1. Use sealers that have a VOC content of not more than 200 g/L when calculated according to 40 CFR 59, Subpart D (EPA Method 24)

2.3 MIXES

A. Epoxy-Resin, Thin-Set Terazzo: Comply with NTMA's "Guide Specification for Epoxy Terrazzo" and resin manufacturer's written instructions for component proportions and mixing.

1. Colors and Patterns: Provide the following based on Terroxy Resin System colors, or equal products.
 - a. T-1 (Corridor Field): TM21-1433
 - b. T-2 (Corridor Border): TM21-1924
 - c. T-3 (Accent Border, Second Floor): TM21-1468
 - d. T-4 (Accent Border, Third Floor): TM21-1469
 - e. T-5 (Accent Border, Fourth Floor): TM21-1470
 - f. T-6: TM21-1467
 - g. Terrazzo Logo/Emblem in Lobby (7'-0" diameter): Four colors as selected by Architect.
2. Thickness: 1/4" or 3/8" depending on aggregates used.

2.4 LOGOS

A. Create custom logo using waterjet technique to cut shapes into which terrazzo is poured. Comply with design indicated on the Drawings and artwork provided by the Architect.

2.5 PRECAST EPOXY TERRAZZO

A. Manufacturers: Subject to compliance with requirements, provide products one of the following or equal:

1. Romoco Precast Terrazzo Products
2. Wausau Tile, Inc.; Terra Paving Products Division
3. Concord Terrazzo Company, Inc.; TERRAZZCO

B. Precast Epoxy Terrazzo Base Units: 1/4 inch (6.4 mm) thick; cast in maximum lengths possible, but not less than 36 inches (900 mm); with rounded, finished top edge.

1. Type: Cove base.
 - a. Provide curved units at cafeteria columns to fit column radius.
2. Height: 6"
3. Outside Corner Units: With finished returned edges at outside corner.
4. Color and Pattern:

- a. At multi-user toilet rooms, match adjacent tile flooring.
 - b. At cafeteria columns, provide scheduled color.
 - c. At ramps, as selected by Architect.
- C. Precast Terrazzo Stair Tread and Riser Units and Cladding for Seating Platform in Cafeteria: Comply with NTMA's written recommendations for fabricating precast cementitious terrazzo units in sizes and profiles indicated. Reinforce units as required by unit sizes, profiles, and thicknesses and as recommended by manufacturer.
1. Type: One-piece tread/riser units
 2. Basis of Design Product: #E-31 manufactured by Wausau Tile or equal.
 3. Colors and Patterns:
 - a. White T-1, where indicated
 - b. Grey T-2, where indicated.
 4. Sizes: As indicated on Drawings
 5. Thickness: 3/4" thick
 6. Stair Treads and Landings: Three-line abrasive inserts at nosings in black.
 - a. Abrasive Strips: Fabricate with surface of abrasive strip positioned 1/16 inch (1.6 mm) higher than terrazzo surface
 7. Edges at Seating Platforms: Eased radius and polished.
 8. Seams at Precast Stairs and Seating Platforms: As indicated on Drawings.
- D. Precast Terrazzo Thresholds: Comply with NTMA's written recommendations for fabricating precast cementitious terrazzo units in sizes and profiles indicated. Reinforce units as required by unit sizes, profiles, and thicknesses and as recommended by manufacturer. thresholds shall be ADA compliant. Sizes and profiles as indicated on Drawings.
- E. Setting Materials for Precast Terrazzo:
1. Epoxy Adhesive: Two component, compatible with terrazzo units and substrate.

PART 3 - EXECUTION

3.1 EXAMINATION

- A. Examine substrates and areas, with Installer present, for compliance with requirements for installation tolerances and other conditions affecting performance of terrazzo. Do not proceed with installation until unsatisfactory conditions, including levelness tolerances, have been corrected.
- B. Concrete Subfloors: Verify that concrete slabs comply with ASTM F 710 and the following:

1. Slab substrates are dry and free of curing compounds, sealers, hardeners, and other materials whose presence would interfere with bonding of terrazzo
 2. Finishes of subfloors comply with tolerances and other requirements specified in Division 03 Section "Cast-In-Place Concrete" for slabs receiving resilient flooring.
 3. Subfloors are free of cracks, ridges, depressions, scale, and foreign deposits of any kind.
 4. Verify that concrete substrates are dry and moisture-vapor emissions are within acceptable levels according to manufacturer's written instructions
- C. Concrete Moisture Emission Tests: Perform calcium chloride test or relative humidity test as per manufacturer's directions, as follows, and other tests if recommended by terrazzo flooring manufacturer:
1. Perform moisture test at rate of one per 2,000 sq.ft. of floor area to be finished.
 2. Report test results in writing to Architect, and Contractor within 24 hours after tests are completed. Reports of concrete moisture emission tests shall contain the Project identification name and number, date of test location of test within structure.
 3. Perform additional moisture emission tests of in-place concrete when test results indicate specified moisture content has been exceeded, as directed by Architect.
 - a. Repeat test one week after initial test minimally and additionally repeat test if required by field conditions to determine moisture levels in area of terrazzo flooring application.
- D. Do not proceed with installation until unsatisfactory conditions have been corrected or after installation of moisture-vapor-emission-control membrane on substrate areas that fail testing.

3.2 PREPARATION

- A. Prepare thin-set-terrazzo substrates according to resin manufacturer's written instructions.
1. Clean substrates of substances that impair terrazzo's bond, including oil, grease, and curing compounds.
 2. Repair damaged and deteriorated concrete substrates to acceptable condition.
 3. Level existing concrete subfloor to required flatness tolerances; not to vary more than 1/4 inch from true plane in a 10 foot span.
 4. Roughen concrete substrates before installing terrazzo according to NTMA's and epoxy flooring manufacturer's written recommendations.
 5. Leave surface free of dust, dirt, laitance and efflorescence.
- B. Cracks: Locate cracks and joints in concrete substrates. Verify location of control joints and expansion joints in epoxy terrazzo flooring.
1. After examining existing conditions of substrate, prepare and submit a written report of existing conditions and Installer's proposed plan for installation of crack suppression membrane; include specific recommendations on type and location of crack suppression membrane system to be provided. Obtain Architect's approval

of proposed plan before commencing with installation of crack suppression membrane system.

- C. Moisture-Vapor-Emission-Control Membrane: Install according to manufacturer's written instructions.
 - 1. Install on concrete substrates that fail preinstallation moisture testing.
- D. Substrate-Crack-Suppression Membrane: Install crack suppression/isolation membrane in accordance with manufacturer's recommendations and as per Installer's approved plan.
 - 1. Prepare and prefill substrate cracks with membrane material.
 - 2. Install membrane in areas to receive terrazzo.
 - 3. Reinforce membrane with fiberglass scrim as required.
- E. Protect other work from dust generated by grinding operations. Control dust to prevent air pollution and comply with governing environmental protection regulations.
 - 1. Erect and maintain temporary enclosures and other suitable methods to limit dust migration and to ensure adequate ambient temperatures and ventilation conditions during installation.

3.3 EPOXY TERRAZZO INSTALLATION

- A. General: Comply with NTMA Guide Specification for terrazzo type indicated and NTMA's written recommendations for substrate preparation and terrazzo installation.
- B. Prime thin-set-terrazzo substrates according to resin manufacturer's written instructions.
- C. Install divider and accessory strips according to NTMA's written recommendations.
- D. Install control-joint strips back-to-back directly above substrate control joints and according to NTMA's written recommendations.
- E. Install angle- or T-type strips and similar accessories in adhesive setting bed without voids below strips. Provide mechanical anchorage of strips as required for adequate attachment of strips to substrate.
- F. Install and finish poured-in-place terrazzo base at the same time the adjacent terrazzo flooring is installed.
- G. Assemble logo template on substrate by installing waterjet cut shapes, shop-fabricated and shipped to the site, as per approved template and layout shop drawing. Logo surface shall be level with surrounding terrazzo floor surface. Fill shapes with terrazzo to match approved colored rendering shop drawing.
- H. Thin-Set Terrazzo: Place, cure, grind, grout, and finish thin-set terrazzo according to resin manufacturer's written instructions and NTMA Guide Specification for thin-set terrazzo

type indicated. Ensure fluids from grinding operations do not react with divider and control-joint strips and stain marble chips. Delay fine grinding until heavy trade work is complete and construction traffic through area is restricted.

- I. Cut out and replace terrazzo areas that evidence lack of bond with substrate or underbed, including areas that emit a "hollow" sound when tapped. Cut out terrazzo areas in panels defined by strips and replace to match adjacent terrazzo, or repair panels according to NTMA's written recommendations, as approved by Architect.
- J. Construction Tolerances: Limit terrazzo surfaces' variation from level to 1/4 inch in 10 feet (6.4 mm in 3 m).

3.4 PRECAST EPOXY TERRAZZO

- A. Set units using method recommended by NTMA and manufacturer unless otherwise indicated. Set units with alignment level and true to dimensions, varying 1/8 inch (3.2 mm) maximum in length, height, or width.
 - 1. Use epoxy adhesive to install treads, risers, seating platform units, thresholds and wall base according to ANSI 108.6.
- B. Seal joints between units with joint sealants.

3.5 CLEANING AND PROTECTING

- A. Remove grinding dust from installation and adjacent areas.
- B. Cure the thin-set epoxy terrazzo flooring in compliance with manufacturer's directions, taking care to prevent contamination during stages of the installation and prior to completion of the curing process.
- C. Rinse surfaces with water and allow to dry thoroughly.
- D. Seal surfaces according to NTMA's written recommendations. Apply sealer according to sealer manufacturer's written instructions.
- E. Protect the thin-set epoxy terrazzo flooring system from damage and wear during other phases of the construction operation, using temporary coverings as recommended by the manufacturer, if required. Remove temporary covering just prior to Substantial Completion.
- F. Clean the thin-set epoxy terrazzo flooring system just prior to final inspection, using materials and procedures suitable to the system manufacturer.

END OF SECTION 096623

SECTION 096813 - TILE CARPETING

PART 1 - GENERAL

1.1 SUMMARY

- A. Section includes modular carpet tile.
- B. Related Requirements:
 - 1. Division 09 Section "Resilient Flooring and Accessories" for resilient wall base and accessories installed with carpet tile.

1.2 PREINSTALLATION MEETINGS

- A. Preinstallation Conference: Conduct conference at Project site
 - 1. Review methods and procedures related to carpet tile installation including, but not limited to, the following:
 - a. Review delivery, storage, and handling procedures.
 - b. Review ambient conditions and ventilation procedures.
 - c. Review subfloor preparation procedures.

1.3 ACTION SUBMITTALS

- A. Product Data: For each type of product.
 - 1. Include manufacturer's written data on physical characteristics, durability, and fade resistance.
 - 2. Include installation recommendations for each type of substrate.
- B. Shop Drawings: Show the following:
 - 1. Columns, doorways, enclosing walls or partitions, built-in cabinets, and locations where cutouts are required in carpet tiles.
 - 2. Carpet tile type, color, and dye lot.
 - 3. Type of subfloor.
 - 4. Type of installation.
 - 5. Pattern of installation.
 - 6. Pattern type, location, and direction.
 - 7. Pile direction.
 - 8. Type, color, and location of insets and borders.
 - 9. Type, color, and location of edge, transition, and other accessory strips.
 - 10. Transition details to other flooring materials.
- C. Samples: For each of the following products and for each color and texture required. Label each Sample with manufacturer's name, material description, color, pattern, and designation indicated on Drawings and in schedules.

1. Carpet Tile: Full-size Sample.
 2. Exposed Edge, Transition, and Other Accessory Stripping: 12-inch- (300-mm-) long Samples.
- D. Product Schedule: For carpet tile. Use same designations indicated on Drawings.
- E. Maintenance Data: For carpet tile to include in maintenance manuals specified in Division 01. Include the following:
1. Methods for maintaining carpet tile, including cleaning and stain-removal products and procedures and manufacturer's recommended maintenance schedule.
 2. Precautions for cleaning materials and methods that could be detrimental to carpet tile.
- F. Sustainability: Provide the Statement of the Achievement Level the carpet has attained for Gold, 52 to 70 points, based on specific Sustainable Attribute Performance for all product stages according to ANSI/NSF 140.

1.4 INFORMATIONAL SUBMITTALS

- A. Qualification Data: For Installer.
- B. Product Test Reports: For carpet tile, for tests performed by a qualified testing agency.
- C. Sample Warranty: For special warranty.

1.5 CLOSEOUT SUBMITTALS

- A. Maintenance Data: For carpet tiles to include in maintenance manuals. Include the following:
 1. Methods for maintaining carpet tile, including cleaning and stain-removal products and procedures and manufacturer's recommended maintenance schedule.
 2. Precautions for cleaning materials and methods that could be detrimental to carpet tile.

1.6 MAINTENANCE MATERIAL SUBMITTALS

- A. Furnish extra materials, from the same product run, that match products installed and that are packaged with protective covering for storage and identified with labels describing contents.
 1. Carpet Tile: Full-size units equal to 5 percent of amount installed for each type indicated, but not less than 10 sq. yd. (8.3 sq. m).

1.7 QUALITY ASSURANCE

- A. Installer Qualifications: An experienced installer who is certified by the International Certified Floorcovering Installers Association at the Commercial II certification level.
- B. Performance Characteristics of Carpet Tile: Provide carpet tile identical to that tested for the following performance characteristics, per test methods indicated:
 - 1. Flammability: Passes DOC FF 1-70 Pill Test.
 - 2. Flame Spread: Meets NFPA Class 1 when tested under ASTM E-648 Glue Down.
 - 3. Smoke Density: 450 or less, Flaming Mode when tested under NBS Smoke Chamber NFPA-258.
 - 4. Static: No more than 3.5 KV when tested under AATCC-134.
 - 5. Specific Optical Density: Not more than 300 in first 4 minutes tested in flaming or non-flaming mode when tested under ASTM E662.
 - 6. Critical Radiant Flux: 0.45 watts per sq. cm or more per ASTM E 648 or NFPA 253.
- C. Mockups: Before installing carpet tile, install mockups for each type of carpet tile installation required to demonstrate aesthetic effects and qualities of materials and execution. Install mockups to comply with the following requirements, using materials indicated for the completed Work:
 - 1. Install mockups in the location and of the size indicated or, if not indicated, as directed by Architect.
 - 2. Notify Architect seven days in advance of dates and times when mockups will be installed.
 - 3. Demonstrate the proposed range of aesthetic effects and workmanship.
 - 4. Obtain Architect's approval of mockups before starting work.
 - 5. Maintain mockups during construction in an undisturbed condition as a standard for judging the completed Work.
 - 6. Remove mockups when directed.
 - 7. Approved mockups may become part of the completed Work if undamaged at time of Substantial Completion..

1.8 DELIVERY, STORAGE, AND HANDLING

- A. Comply with CRI Carpet Installation Standard 2011.
- B. Store carpeting per manufacturer's recommendations for allowable temperature and humidity range. Products shall not be allowed to become damp.
- C. Remove carpeting from packaging and store in unoccupied, ventilated areas (100% outside air supply, minimum of 1.5 air changes per hour, no recirculation) for 24-72 hours prior to installation. Carpeting shall not be stored with materials which have high emissions of VOCs or other contaminants. Materials with high short-term emissions include, but are not limited to: adhesives, sealants and glazing compounds (specifically those with petrochemical vehicles or carriers); paint, wood preservatives, and finishes; control and/or expansion joint fillers; hard finishes requiring adhesive installation;

gypsum board (with associated finish processes and products); and composite or engineered wood products with formaldehyde binders

1.9 FIELD CONDITIONS

- A. Comply with CRI Carpet Installation Standard 2011 for temperature, humidity, and ventilation limitations.
- B. Environmental Limitations: Do not deliver or install carpet tiles until spaces are enclosed and weathertight, wet work in spaces is complete and dry, and ambient temperature and humidity conditions are maintained at occupancy levels during the remainder of the construction period.
- C. Do not install carpet tiles over concrete slabs until slabs have cured and are sufficiently dry to bond with adhesive and concrete slabs have pH range recommended by carpet tile manufacturer.
- D. Where demountable partitions or other items are indicated for installation on top of carpet tiles, install carpet tiles before installing these items.

1.10 WARRANTY

- A. Special Warranty for Carpet Tiles: Manufacturer agrees to repair or replace components of carpet tile installation that fail in materials or workmanship within specified warranty period.
 - 1. Warranty does not include deterioration or failure of carpet tile due to unusual traffic, failure of substrate, vandalism, or abuse.
 - 2. Failures include, but are not limited to, more than 10 percent edge raveling, snags, runs, dimensional stability, excess static discharge, loss of tuft bind strength, loss of face fiber, and delamination.
 - 3. Warranty Period: Lifetime.

PART 2 - PRODUCTS

2.1 CARPET TILE

- A. Manufacturers: Provide specified Basis of Design products or equal manufactured by one of the following manufacturers:
 - 1. Interface
 - 2. Mannington
 - 3. Milikin
 - 4. Mohawk Commercial Carpet
 - 5. Shaw
 - 6. Tandus Centiva
- B. Sustainable Carpet Certification: Provide carpet tile that has a NSF/ANSI 140 rating of Gold or better.

- C. Emissions: Provide carpet tile that complies with testing and product requirements of Carpet and Rug Institute's "Green Label Plus" program.
- D. Carpet Tile CPT1:
 - 1. Construction: Stratatec patterned loop pile
 - 2. Fiber Content: Antron Lumina Nylon
 - 3. Dye Method: Solution dyed
 - 4. Machine Gage: 5/64 in.
 - 5. Pile Thickness: 0.080 in
 - 6. Average Pile Height: 0.185 in.
 - 7. Stitches per Inch: 10
 - 8. Primary Backing: Synthetic non woven
 - 9. Secondary Backing: ethos Modular
 - 10. Size: 24 in x 24 in
 - 11. Guarantees: Lifetime limited.
 - 12. Basis of Design Product: Tarkett "2ndPower" 04987.
 - 13. Color(s): Storm Trooper 71607
 - 14. Installation: Vertical Ashlar
 - 15. Location: Offices.
- E. Trowelable Leveling and Patching Compounds: Latex-modified, hydraulic-cement-based formulation provided or recommended by carpet tile manufacturer.
- F. Adhesives: Water-resistant, mildew-resistant, nonstaining, pressure-sensitive type to suit products and subfloor conditions indicated, that complies with flammability requirements for installed carpet tile and is recommended by carpet tile manufacturer for releasable installation.
 - 1. Adhesives shall have a VOC content of 50 g/L or less when calculated according to 40 CFR 59, Subpart D (EPA Method 24).
- G. Metal Edge/Transition Strips: Extruded aluminum with mill finish of profile and width shown, of height required to protect exposed edge of carpet, and of maximum lengths to minimize running joints.
- H. Carpet Edge Guard: Refer to Division 09 Section "Resilient Flooring and Accessories."

PART 3 - EXECUTION

3.1 EXAMINATION

- A. Examine substrates, areas, and conditions, with Installer present, for compliance with requirements for maximum moisture content, alkalinity range, installation tolerances, and other conditions affecting carpet tile performance. Examine carpet tile for type, color, pattern, and potential defects.
- B. Concrete Subfloors: Verify that concrete slabs comply with ASTM F 710 and the following:

1. Slab substrates are dry and free of curing compounds, sealers, hardeners, and other materials that may interfere with adhesive bond. Determine adhesion and dryness characteristics by performing bond and moisture tests recommended by carpet tile manufacturer. Do not install flooring if subfloor moisture emission rate exceeds indicated amounts.
 - a. Calcium Chloride Testing: Perform anhydrous calcium chloride test, ASTM F 1869. Proceed with installation only after substrates do not exceed the maximum moisture-vapor-emission rate acceptable to flooring manufacturer.
 - b. Moisture Meter Testing: Perform relative humidity test using in situ probes, ASTM F 2170. Proceed with installation only after substrates have relative humidity level measurement acceptable to flooring material manufacturer.
 - c. Testing Procedures
 - 1) Where flooring is indicated to be applied to structural concrete topping or concrete slab-on-grade substrates, perform moisture meter tests.
 - 2) Where flooring is indicated to be applied to areas where hydraulic cement topping is installed, perform calcium chloride or moisture meter tests as required by topping manufacturer.
2. Subfloor finishes comply with requirements specified in Section 033000 "Cast-in-Place Concrete" for slabs receiving carpet tile.
3. Subfloors are free of cracks, ridges, depressions, scale, and foreign deposits.

C. Proceed with installation only after unsatisfactory conditions have been corrected.

3.2 PREPARATION

- A. General: Comply with CRI Carpet Installation Standard 2011, Section 7, "Site Conditions; All Installations," and with carpet tile manufacturer's written installation instructions for preparing substrates indicated to receive carpet tile installation.
- B. Use trowelable leveling and patching compounds, according to manufacturer's written instructions, to fill cracks, holes, depressions, and protrusions in substrates. Fill or level cracks, holes and depressions 1/8 inch (3 mm) wide or wider and protrusions more than 1/32 inch (0.8 mm) unless more stringent requirements are required by manufacturer's written instructions.
- C. Remove coatings, including curing compounds, and other substances that are incompatible with adhesives and that contain soap, wax, oil, or silicone, without using solvents. Use mechanical methods recommended in writing by carpet tile manufacturer.
- D. Clean metal substrates of grease, oil, soil and rust, and prime if directed by adhesive manufacturer. Rough sand painted metal surfaces and remove loose paint. Sand aluminum surfaces, to remove metal oxides, immediately before applying adhesive.

- E. Broom and vacuum clean substrates to be covered immediately before installing carpet tile.

3.3 INSTALLATION

- A. General: Comply with CRI Carpet Installation Standard 2011, Section 18, "Modular Carpet," and with carpet tile manufacturer's written installation instructions.
- B. Installation Method: As recommended in writing by carpet tile manufacturer.
- C. Maintain dye lot integrity. Do not mix dye lots in same area.
- D. Cut and fit carpet tile to butt tightly to vertical surfaces, permanent fixtures, and built-in furniture including cabinets, pipes, outlets, edgings, thresholds, and nosings. Bind or seal cut edges as recommended by carpet tile manufacturer.
- E. Extend carpet tile into toe spaces, door reveals, closets, open-bottomed obstructions, removable flanges, alcoves, and similar openings.
- F. Maintain reference markers, holes, and openings that are in place or marked for future cutting by repeating on finish flooring as marked on subfloor. Use nonpermanent, nonstaining marking device.
- G. Install pattern parallel to walls and borders, unless otherwise indicated.

3.4 CLEANING AND PROTECTION

- A. Perform the following operations immediately after installing carpet tile:
 - 1. Remove excess adhesive, seam sealer, and other surface blemishes using cleaner recommended by carpet tile manufacturer.
 - 2. Remove yarns that protrude from carpet tile surface.
 - 3. Vacuum carpet tile using commercial machine with face-beater element.
- B. Protect installed carpet tile to comply with CRI Carpet Installation Standard 2011, Section 20, "Protecting Indoor Installations."
 - 1. Restrict traffic over adhesive installations for a minimum of 48 hours to allow proper adhesive cure.
 - 2. Restrict exposure to water from cleaning or other sources for a minimum of 30 days.
 - 3. If required to protect the finished floor covering from dirt or paint, or if additional work is to be done after the installation, cover carpeting with a non-staining building material paper.
 - 4. Protect the installation from rolling traffic by using sheets of hardboard or plywood in affected areas.
- C. Protect carpet tile against damage from construction operations and placement of equipment and fixtures during the remainder of construction period. Use protection methods indicated or recommended in writing by carpet tile manufacturer.

13 January 2022
Conformed Specifications
SED #66-23-00-01-0-346-001

Yonkers Joint Schools Construction Board
Community School 35

END OF SECTION 096813

SECTION 097750 - FIBER REINFORCED PLASTIC COATED PANELS

PART 1 - GENERAL

1.1 SUMMARY

- A. This Section includes fiberglass reinforced polyester (FRP) panels and high pressure laminate (HPL) faced fiberglass reinforced plastic (FRP) for cladding walls, columns and casework.

1.2 ACTION SUBMITTALS

- A. Product data for each type of product specified. Include data on physical characteristics, durability, fade resistance, and flame resistance characteristics.
- B. Samples for initial selection purposes of each type and color available for fiber reinforced plastic coated panels and molding accessory required of size indicated below:
 - 1. 3 inch square sample of each fiber reinforced plastic coated panel specified.
 - 2. 6-inch long sample of each molding accessory.

1.3 INFORMATIONAL SUBMITTALS

- A. Product certificates signed by fiber reinforced plastic coated panel manufacturer certifying materials furnished comply with specified requirements.
- B. Certified test reports showing compliance with requirements for fire performance characteristics and physical properties.
- C. Maintenance data for inclusion in Division 01 Section "Closeout Procedures." Include the following:
 - 1. Methods for maintaining fiber reinforced plastic coated panels.
 - 2. Precautions for use of cleaning materials and methods that could be detrimental to finishes and performance.

1.4 QUALITY ASSURANCE

- A. Fire Performance Characteristics: Provide fiber reinforced plastic coated panels with the following surface burning characteristics as determined by testing identical products per ASTM E 84 by UL or other testing and inspecting organizations acceptable to authorities having jurisdiction. Identify fiber reinforced plastic coated panels with appropriate markings of applicable testing and inspecting organization.
 - 1. Flame Spread: 25 or less.
 - 2. Smoke Developed: 450 or less.

- B. Installer Qualifications: Arrange for installation of fiber reinforced plastic coated panels by a firm that can demonstrate successful experience in installing similar in type and quality to those required for this Project.

1.5 DELIVERY, STORAGE, AND HANDLING

- A. Protect units during transit, delivery, storage, and handling to prevent damage, soilage, and deterioration.

1.6 PROJECT CONDITIONS

- A. Maintain a constant temperature not less than 70°F in installation areas for at least ten (10) days before and ten (10) days after installation.
- B. Field Measurements: Where units are indicated to be fitted to other construction, check actual dimensions of other construction by accurate field measurements; show recorded measurements on final shop drawings. Coordinate manufacturing schedule with construction progress to avoid delay of Work.

PART 2 - PRODUCTS

2.1 MANUFACTURERS:

- A. Basis-of-Design Manufacturer: Subject to compliance with requirements, provide FRP products as manufactured by Marlite, Division of Commercial and Architectural Products, Inc. or an approved equivalent by one of the following:
 - 1. Crane Composites, Inc.
 - 2. Kal-Lite.

2.2 FRP PANELS:

- A. FRP Panels: High gloss fiberglass reinforced polyester panels 0.09" thick with pebbled embossed textured surface, Class A fire rating, 4-feet wide by height required.
 - 1. Color: As selected by Architect.
 - 2. Basis of Design Product: Standard FRP by Marlite, or equal.
 - 3. Location: Wall cladding in kitchen, food prep areas and elsewhere as scheduled.
- B. High Pressure Laminate (HPL) faced Fiberglass Reinforced Plastic (FRP): Exceptionally high wear resistant panel fabricated by thermally bonding melamine impregnated surfacing materials directly to the FRP core.
 - 1. Panel Size: 47-1/2" x 95-1/2" x 3/32" (nominal)
 - 2. Class A fire rating
 - 3. Impact Test: ASTM D5420-04 product on 1/2" Drywall; minimal damage

4. Colors:
 - a. Blond Echo #7939 at Cafeteria booths.
 - b. Custom color Formica Sarum Twill #8827-58 oriented horizontally in the Library/Learning Commons for desk and column wrap.
5. Basis of Design Product: Induro by Marlite, or equal.
- C. Accessories: Provide inside corner, outside corner, division molding and edge trim moldings by same manufacturer, matching wall panels.
- D. Adhesive: Manufacturer's standard low odor, VOC compliant, non-flammable latex based adhesive for use and substrate.
- E. Sealant: Manufacturer's standard clear silicone sealant meeting local VOC requirements.

PART 3 - EXECUTION

3.1 PREPARATION

- A. Examine substrates for compliance with requirements for installation tolerances and other conditions affecting installation and performance of fiber reinforced plastic coated panels. Do not proceed with installation until unsatisfactory conditions have been corrected.

3.2 PREPARATION

- A. Clean substrates of projections and substances detrimental to application.
- B. Acclimate panels to room temperature for 48 hours prior to installation.
- C. Follow manufacturer's printed instructions for surface preparation.

3.3 INSTALLATION

- A. Do not use materials that are unsound, warped, bowed or twisted.
- B. Install fiber reinforced plastic coated panels plumb, level, true, and aligned with adjacent materials.
 1. Scribe and cut panels to fit adjoining work.
 2. Install to tolerance of 1/32 inch in 8 feet for plumb and level.
 3. Coordinate with materials and systems that may be in or adjacent to panels. Provide cutouts for mechanical and electrical items that penetrate.
- C. Plan fiber reinforced plastic coated panel layout, balancing panel sizes at corners.
 1. Adhere division molding and work from center of wall to corners.

2. Adhere FRP panels to substrate in accordance with manufacturer's written instructions.
3. Stagger joints between panels and substrate material.
4. Provide moldings at all sides of panels. Adhere ceiling line and curb moldings in place with sealant, and provide sealant in molding channels prior to insertion of panels.
5. Remove excess sealant from panel surfaces immediately.

3.4 ADJUSTING AND CLEANING

- A. Repair damaged or defective fiber reinforced plastic coated panels where possible to eliminate functional or visual defects. Where not possible to repair, replace fiber reinforced plastic coated panels.
- B. Remove excess adhesive at finished seams, perimeter edges, and adjacent surfaces.
- C. Use cleaning methods recommended by the fiber reinforced plastic coated panel manufacturer.
- D. Replace panels that cannot be cleaned.

3.5 PROTECTION

- A. Provide final protection and maintain conditions that ensure panels are without damage or deterioration at time of Substantial Completion.

END OF SECTION 097750

SECTION 098413 - ACOUSTICAL WALL PANELS

PART 1 - GENERAL

1.1 SUMMARY

- A. This Section includes the following:
 - 1. Fabric-wrapped acoustical wall panels.

1.2 SUBMITTALS

- A. Product Data: For each type of fabric, panel edge, acoustical fill and core material specified.
- B. Shop Drawings: Include attachment devices; and details at head, base, joints, corners, and intersections with shelves, countertops, doors, electrical outlets and switches, thermostats, and other components. Indicate panel edge and core materials.
 - 1. Include elevations showing panel sizes and direction of fabric weave.
- C. Samples for Verification: For the following products. Prepare Samples from the same material to be used for the Work.
 - 1. Fabric: Full-width by 36-inch- (1000-mm-) long Sample from dye lot to be used for the Work, with specified treatments applied. Show complete pattern repeat. Mark top and face of fabric.
 - 2. Sample Panels: No larger than 36 by 36 inches (1000 by 1000 mm). Show joints, panel edges, and attachment methods.
- D. Maintenance Data: For acoustical wall panels to include in maintenance manuals specified in Division 01. Include fabric manufacturers cleaning and stain-removal recommendations.

1.3 QUALITY ASSURANCE

- A. Installer Qualifications: An experienced installer who has completed work similar in material, design, and extent to that indicated for this Project and whose work has resulted in installation with a record of successful in-service performance.
- B. Fire-Test-Response Characteristics: Provide acoustical wall panels with the following surface-burning characteristics as determined by testing identical products per ASTM E 84 by UL or another testing and inspecting agency acceptable to authorities having jurisdiction.
 - 1. Flame Spread: 25 or less.
 - 2. Smoke Developed: 450 or less.

- C. Fabric facing shall meet NFPA 701.

1.4 DELIVERY, STORAGE, AND HANDLING

- A. Protect acoustical wall panels from excessive moisture in shipment, storage, and handling. Deliver in unopened bundles and store in a dry place with adequate air circulation.
- B. Before installing acoustical wall panels, permit them to reach room temperature and a stabilized moisture content.

1.5 PROJECT CONDITIONS

- A. Environmental Limitations: Do not install acoustical wall panels until spaces are enclosed and weatherproof, wet-work in spaces is complete and dry, work above ceilings is complete, and ambient temperature and humidity conditions are maintained at the levels indicated for Project when occupied for its intended use.
- B. Field Measurements: Verify acoustical wall panels sizes by field measurements before fabrication and indicate measurements on Shop Drawings. Coordinate fabrication schedule with construction progress to avoid delaying the Work.

1.6 COORDINATION

- A. Coordinate layout and installation of acoustical wall panels with other construction that penetrates panels, including light fixtures, electrical outlets, HVAC thermostats and similar assemblies.

1.7 WARRANTY

- A. General Warranty: Special warranty specified in this Article shall not deprive Owner of other rights Owner may have under other provisions of the Contract Documents and shall be in addition to, and run concurrent with, other warranties made by Contractor under requirements of the Contract Documents.
- B. Special Warranty: Written warranty, signed by acoustical wall panel manufacturer agreeing to repair or replace panels that fail in materials or workmanship within specified warranty period. Failures include, but are not limited to, fabric sagging, distorting, or releasing from panel edge.

- 1. Warranty Period: Two years from date of Substantial Completion.

PART 2 - PRODUCTS

2.1 ACOUSTICAL WALL PANELS

- A. Acoustical Panels: Provide acoustical wall panels as follows:

1. Edge Profile: Square.
2. Edge Material: Resined
3. Nominal Panel Thickness: 2 inch
4. Core: 6 to 7 pcf medium density core glass fiber board
5. Fabric Facing: 56" W Guliford of Maine FR701 Style 2100 in two colors as follows:
 - a. 2' x 2' Panels: Sky 740.
 - b. 1' x 2' Panels: Sapphire 745.
6. Shapes: Flat wall panels in rectangular shape.
7. Size: As indicated on Drawings for each location.
8. Mounting Method: Manufacturer's standard mounting clips and leveling clips concealed attachment system.
9. Basis of Design Product: Decoustics Type AP Acoustic Panels, or equal.

2.2 MATERIALS

- A. Glass-Fiber Board: ASTM C 612, Type IA or Types IA and IB; 6-7 pcf density, unfaced, dimensionally stable, molded rigid board, with maximum flame-spread and smoke-developed indexes of 25 and 50, respectively
- B. Fasteners: Types and sizes recommended by core manufacturer, steel drill screws complying with ASTM C 1002 for applications over steel framing.

2.3 FABRICATION

- A. Acoustical Wall Panels: Fabric straight and on the grain. No seams are allowed.
- B. Apply fabric to smooth side of panel.
- C. Stretch fabric tight and square without puckers, ripples, sagging, or distortions. Adhere fabric to panel face.
- D. Mounting Devices: Concealed mounting clips and leveling clips on back of panel, as supplied by manufacturer to support weight of panel and for substrate being fastened to.

PART 3 - EXECUTION

3.1 EXAMINATION

- A. Examine fabric, substrates, and conditions, with Installer present, for compliance with requirements, installation tolerances, and other conditions affecting performance of acoustical wall panels.
 1. Proceed with installation only after unsatisfactory conditions have been corrected.

3.2 INSTALLATION

- A. Install acoustical wall panels in locations indicated with vertical surfaces and edges plumb, top edges level and in alignment with other panels, and scribed to fit adjoining work accurately at borders and at penetrations; and with fabric installed square to the grain. Comply with panel core manufacturer's written instructions for installation of panels using type of mounting accessories indicated or, if not indicated, as recommended by manufacturer.
 - 1. Coordinate panel layout with steel framing locations for fastener placing and spacing
- B. Panel Joints: No greater than 1/16-inch expansion space between adjoining panels, and 1/4-inch at floor, ceiling and around windows and door frames, etc.
- C. Take care in handling panels with clean hands, so as not to soil fabric material.
- D. Attach acoustical wall panels to underlying construction according to manufacturer's written instructions, by mechanically fasten panels to metal framing members, through use of z-clip system, or adhesively fasten to substrate as per manufacturer's directions.
- E. At exterior corners, butt panels together with light contact to produce close fitting, uniform joints. Do not force panels into place.
- F. At interior corners, butt adjoining panels together with light contact to produce close fitting, uniform joints. Do not force panels into place.
- G. At vertical joints between panels in the same plane, butt panels at edges with light contact to produce close fitting, uniform joints. Do not force panels into place.
- H. Cut holes in panels for services according to manufacturer's written instructions to avoid loosening facing at openings.

3.3 CLEANING AND PROTECTING

- A. Clean exposed faces of installed panels, and related materials, and adjacent surfaces. Comply with fabric manufacturer's recommendations for cleaning methods and materials.
- B. Provide final protection and maintain conditions, in a manner acceptable to manufacturer and Installer, that ensure installation is without damage or deterioration at the time of Substantial Completion.

END OF SECTION 098413

SECTION 099100 - PAINTING

PART 1 - GENERAL

1.1 SUMMARY

- A. This Section includes surface preparation and the application of paint and stain systems on the following interior and exterior substrates:
1. Concrete masonry units (CMU).
 2. Concrete
 3. Steel and iron.
 4. Galvanized metal.
 5. Gypsum board.
 6. Wood
 7. Metal decking and framing at ceilings
 8. Tectum panels at ceilings.
- B. Related Sections include the following:
1. Division 05 Sections for shop priming of metal substrates with primers specified in this Section.

1.2 ACTION SUBMITTALS

- A. Product Data: For each type of product indicated.
- B. Shp Drawings: Provide for individually painted numerals in stairwell. Include elevations, and full-size templates of typical numeral.
- C. Samples for Initial Selection: For each type of topcoat product indicated.
- D. Samples for Verification: For each type of paint system and in each color and gloss of topcoat indicated.
1. Submit Samples on rigid backing, 8 inches (200 mm) square.
 2. Step coats on Samples to show each coat required for system.
 3. Label each coat of each Sample.
 4. Label each Sample for location and application area.
- E. Product List: For each product indicated, include the following:
1. Cross-reference to paint system and locations of application areas. Use same designations indicated on Drawings and in schedules.
 2. Printout of current "MPI Approved Products List" for each product category specified in Part 2, with the proposed product highlighted.

1.3 INFORMATIONAL SUBMITTALS

- A. Qualifications of applicator of painted numerals on stairwell walls.

1.4 QUALITY ASSURANCE

- A. MPI Standards: Maintain copy of this standard at the Project site at all times.
 - 1. Products: Complying with MPI standards indicated and listed in "MPI Approved Products List."
 - 2. Preparation and Workmanship: Comply with requirements in "MPI Architectural Painting Specification Manual" for products and paint systems indicated.
- B. Mockups: Apply benchmark samples of each paint system indicated and each color and finish selected to verify preliminary selections made under sample submittals and to demonstrate aesthetic effects and set quality standards for materials and execution.
 - 1. Architect will select one surface to represent surfaces and conditions for application of each paint system specified in Part 3.
 - a. Wall and Ceiling Surfaces: Provide samples of at least 100 sq. ft.
 - b. Stained Concrete Floor: Provide samples of at least 100 sq. ft.
 - c. Painted Numerals in Stairwell: Provide one full size numeral.
 - d. Other Items: Architect will designate items or areas required.
 - 2. Apply benchmark samples after permanent lighting and other environmental services have been activated.
 - 3. Final approval of color selections will be based on benchmark samples.
 - a. If preliminary color selections are not approved, apply additional benchmark samples of additional colors selected by Architect at no added cost to Owner.
- C. Applicator Qualifications for Painted Numerals in Stairwell: Professional sign painter with minimum 5 years of sign painting experience similar in nature to work of this project.

1.5 DELIVERY, STORAGE, AND HANDLING

- A. Store materials not in use in tightly covered containers in well-ventilated areas with ambient temperatures continuously maintained at not less than 45 deg F (7 deg C).
 - 1. Maintain containers in clean condition, free of foreign materials and residue.
 - 2. Remove rags and waste from storage areas daily.

1.6 PROJECT CONDITIONS

- A. Apply paints only when temperature of surfaces to be painted and ambient air temperatures are between 50 and 95 deg F (10 and 35 deg C).
- B. Do not apply paints when relative humidity exceeds 85 percent; at temperatures less than 5 deg F (3 deg C) above the dew point; or to damp or wet surfaces.

- C. Do not apply paints in snow, rain, fog, or mist; when relative humidity exceeds 85 percent; at temperatures less than 5 deg F (3 deg C) above the dew point; or to damp or wet surfaces.

PART 2 - PRODUCTS

2.1 MANUFACTURERS

- A. Manufacturers: Subject to compliance with requirements, provide products by one of the following:
 - 1. Benjamin Moore & Co.
 - 2. PPG Architectural Finishes, Inc.
 - 3. Sherwin-Williams Company (The).
 - 4. Tnemec

2.2 PAINT, GENERAL

- A. Material Compatibility:
 - 1. Provide materials for use within each paint system that are compatible with one another and substrates indicated, under conditions of service and application as demonstrated by manufacturer, based on testing and field experience.
 - 2. For each coat in a paint system, provide products recommended in writing by manufacturers of topcoat for use in paint system and on substrate indicated.
- B. VOC Content of Field-Applied Interior Paints and Coatings: Provide products that comply with the following limits for VOC content, exclusive of colorants added to a tint base, when calculated according to 40 CFR 59, Subpart D (EPA Method 24) and the OTC (Ozone Transport Commission) restrictions; these requirements do not apply to paints and coatings that are applied in a fabrication or finishing shop:
 - 1. Flat Paints, Coatings, and Primers: VOC content of not more than 50 g/L.
 - 2. Nonflat Paints, Coatings, and Primers: VOC content of not more than 150 g/L.
 - 3. Anti-Corrosive and Anti-Rust Paints Applied to Ferrous Metals: VOC not more than 250 g/L.
 - 4. Floor Coatings: VOC not more than 100 g/L.
 - 5. Shellacs, Clear: VOC not more than 730 g/L.
 - 6. Shellacs, Pigmented: VOC not more than 550 g/L.
 - 7. Flat Topcoat Paints: VOC content of not more than 50 g/L.
 - 8. Nonflat Topcoat Paints: VOC content of not more than 150 g/L.
 - 9. Anti-Corrosive and Anti-Rust Paints Applied to Ferrous Metals: VOC not more than 250 g/L.
 - 10. Floor Coatings: VOC not more than 100 g/L.
 - 11. Shellacs, Clear: VOC not more than 730 g/L.
 - 12. Shellacs, Pigmented: VOC not more than 550 g/L.
 - 13. Primers, Sealers, and Undercoaters: VOC content of not more than 200 g/L.

14. Dry-Fog Coatings: VOC content of not more than 400 g/L.
 15. Zinc-Rich Industrial Maintenance Primers: VOC content of not more than 340 g/L.
 16. Pre-Treatment Wash Primers: VOC content of not more than 420 g/L.
 17. Fire Retardant Paint: VOC content of not more than 60 g/L.
- C. Colors: As scheduled on the Paint Color List following this section. Colors listed are for color matching purposes only.

PART 3 - EXECUTION

3.1 EXAMINATION

- A. Examine substrates and conditions, with Applicator present, for compliance with requirements for maximum moisture content and other conditions affecting performance of work.
- B. Maximum Moisture Content of Substrates: When measured with an electronic moisture meter as follows:
1. Concrete: 12 percent.
 2. Masonry: 12 percent.
 3. Gypsum Board: 12 percent.
 4. Wood: 15 percent
- C. Verify suitability of substrates, including surface conditions and compatibility with existing finishes and primers.
- D. Begin coating application only after unsatisfactory conditions have been corrected and surfaces are dry.
1. Beginning coating application constitutes Contractor's acceptance of substrates and conditions.

3.2 PREPARATION

- A. Comply with manufacturer's written instructions and recommendations in "MPI Architectural Painting Specification Manual" applicable to substrates indicated.
- B. Remove plates, machined surfaces, and similar items already in place that are not to be painted. If removal is impractical or impossible because of size or weight of item, provide surface-applied protection before surface preparation and painting.
1. After completing painting operations, use workers skilled in the trades involved to reinstall items that were removed. Remove surface-applied protection if any.
 2. Do not paint over labels of independent testing agencies or equipment name, identification, performance rating, or nomenclature plates.

- C. Clean substrates of substances that could impair bond of paints, including dirt, oil, grease, and incompatible paints and encapsulants.
 - 1. Remove incompatible primers and reprime substrate with compatible primers as required to produce paint systems indicated.
- D. Concrete Substrates: Remove release agents, curing compounds, efflorescence, and chalk. Do not paint surfaces if moisture content or alkalinity of surfaces to be painted exceeds that permitted in manufacturer's written instructions.
- E. Concrete Masonry Substrates: Remove efflorescence and chalk. Do not paint surfaces if moisture content or alkalinity of surfaces to be painted exceeds that permitted in manufacturer's written instructions.
- F. Steel Substrates: Remove rust and loose mill scale. Clean using methods recommended in writing by paint manufacturer.
- G. Galvanized-Metal Substrates: Remove grease and oil residue from galvanized sheet metal fabricated from coil stock by mechanical methods to produce clean, lightly etched surfaces that promote adhesion of subsequently applied paints.
- H. Gypsum Board Substrates: Do not begin paint application until finishing compound is dry and sanded smooth.
- I. Wood: Clean surfaces of dirt, oil, and other foreign substances with scrapers, mineral spirits, and sandpaper, as required. Sand surfaces exposed to view smooth and dust off.
 - 1. Scrape and clean small, dry, seasoned knots, and apply a thin coat of white shellac or other recommended knot sealer before applying primer. After priming, fill holes and imperfections in finish surfaces with putty or plastic wood filler. Sand smooth when dried.
 - 2. Prime, stain, or seal wood to be painted immediately on delivery. Prime edges, ends, faces, undersides, and backsides of wood, including cabinets, counters, cases, and paneling.
 - 3. Seal tops, bottoms, and cutouts of unprimed wood doors with a heavy coat of varnish or sealer immediately on delivery.
 - 4. When transparent finish is required, backprime with spar varnish or polyurethane.

3.3 APPLICATION

- A. Apply paints according to manufacturer's written instructions.
 - 1. Use applicators and techniques suited for paint and substrate indicated.
 - 2. Paint surfaces behind movable equipment and furniture same as similar exposed surfaces. Before final installation, paint surfaces behind permanently fixed equipment or furniture with prime coat only.
 - 3. Paint front and backsides of access panels, removable or hinged covers, and similar hinged items to match exposed surfaces.

- B. Application Procedures: Apply paints and coatings by brush or roller according to the manufacturer's directions, except as noted below. Spray application is not permitted for trim, ceilings and walls, unless specifically approved by Architect in advance for each individual situation. Roller application on woodwork is not permitted.
1. Apply paints to produce surface films without cloudiness, spotting, holidays, laps, brush marks, roller tracking, runs, sags, ropiness, or other surface imperfections. Cut in sharp lines and color breaks.
 2. Brushes: Use brushes best suited for the type of material applied. Use brush of appropriate size for the surface or item being painted.
 3. Rollers: Use rollers of carpet, velvet back, or high-pile sheep's wool as recommended by the manufacturer for the material and texture required.
- C. Minimum Coating Thickness: Apply paint materials no thinner than manufacturer's recommended spreading rate. Provide the total dry film thickness of the entire system as recommended by the manufacturer.
- D. Tint each undercoat a lighter shade to facilitate identification of each coat if multiple coats of same material are to be applied. Tint undercoats to match color of topcoat, but provide sufficient difference in shade of undercoats to distinguish each separate coat.
- E. If undercoats or other conditions show through topcoat, apply additional coats until cured film has a uniform paint finish, color, and appearance.
- F. Apply paints to produce surface films without cloudiness, spotting, holidays, laps, brush marks, roller tracking, runs, sags, ropiness, or other surface imperfections. Cut in sharp lines and color breaks.
- G. Painting Mechanical and Electrical Work: Paint items exposed in equipment rooms and occupied spaces including, but not limited to, the following:
1. Mechanical Work:
 - a. Uninsulated metal piping.
 - b. Uninsulated plastic piping.
 - c. Pipe hangers and supports.
 - d. Tanks that do not have factory-applied final finishes.
 - e. Visible portions of internal surfaces of metal ducts, without liner, behind air inlets and outlets.
 - f. Duct, equipment, and pipe insulation having cotton or canvas insulation covering or other paintable jacket material.
 - g. Mechanical equipment that is indicated to have a factory-primed finish for field painting.
 2. Electrical Work:
 - a. Switchgear.
 - b. Panelboards.
 - c. Electrical equipment that is indicated to have a factory-primed finish for field painting.

3.4 FIELD QUALITY CONTROL

- A. Testing of Paint Materials: Owner reserves the right to invoke the following procedure at any time and as often as Owner deems necessary during the period when paints are being applied:
1. Owner will engage the services of a qualified testing agency to sample paint materials being used. Samples of material delivered to Project site will be taken, identified, sealed, and certified in presence of Contractor.
 2. Testing agency will perform tests for compliance with product requirements.
 3. Owner may direct Contractor to stop applying paints if test results show materials being used do not comply with product requirements. Contractor shall remove noncomplying-paint materials from Project site, pay for testing, and repaint surfaces painted with rejected materials. Contractor will be required to remove rejected materials from previously painted surfaces if, on repainting with complying materials, the two paints are incompatible.

3.5 CLEANING AND PROTECTION

- A. At end of each workday, remove rubbish, empty cans, rags, and other discarded materials from Project site.
- B. After completing paint application, clean spattered surfaces. Remove spattered paints by washing, scraping, or other methods. Do not scratch or damage adjacent finished surfaces.
- C. Protect work of other trades against damage from paint application. Correct damage to work of other trades by cleaning, repairing, replacing, and refinishing, as approved by Architect, and leave in an undamaged condition.
- D. At completion of construction activities of other trades, touch up and restore damaged or defaced painted surfaces.

3.6 EXTERIOR PAINTING SCHEDULE

- A. General: Provide listed products or equal products of other named manufacturers in Part 2.
- B. Steel and Iron Substrates: Polyurethane, Pigmented, Epoxy Zinc Rich Primer and High-Build Epoxy Coating System: Gloss or Semi-Gloss as selected by the Architect.
1. Prime Coat: Epoxy Zinc Rich Primer. Tnemec: Tneme-Zinc Series 90-97 or equal.
 2. Intermediate Coat: High-performance, polyamide-epoxy coating; High-Build Epoxy Marine Coating, Low Gloss: Tnemec: Hi-Build Epoxoline, Series 66, tinted slightly lighter than top coat., or equal
 3. Topcoat (Gloss)t: Aliphatic Acrylic Polyurethane, Two-Component, Pigmented, Gloss: Tnemec Endura-Shield II Series 1074.
 4. Topcoat (Semi-Gloss)t: Aliphatic Acrylic Polyurethane, Two-Component, Pigmented, Semi-Gloss: Tnemec Endura-Shield II Series 1075.

- C. Zinc-Coated (Galvanized) Metal: Full-gloss, acrylic latex enamel finish - 2 coats - self-priming.
 - 1. Prime Coat: Gloss acrylic latex enamel paint; MPI # 114, X-Green 114, 154, X-Green 154, 164, LEED 2009, LEED V4.
 - a. Benjamin Moore Ultra Spec D.T.M. Acrylic Gloss Enamel HP28
 - 2. Top Coat: Gloss acrylic latex enamel paint; MPI # 114, X-Green 114, 154, X-Green 154, 164, LEED 2009, LEED V4.
 - a. Benjamin Moore Ultra Spec D.T.M. Acrylic Gloss Enamel HP28

3.7 INTERIOR PAINTING SCHEDULE

- A. General: Provide listed products or equal products of other named manufacturers in Part 2.
- B. Gypsum Board Ceilings: Eggshell acrylic finish.
 - 1. Prime Coat: Latex-based, interior primer; MPI # 50, X-Green 50, 149, X-Green 149, LEED 2009, LEED V4, CHPS Certified.
 - a. Benjamin Moore; Ultra Spec 500 Interior Latex Primer N534
 - 2. Intermediate Coat and Topcoat: Low-luster (eggshell or satin), acrylic-latex, interior enamel; MPI # 52, X-Green 52, 145, X-Green 145, 139, X-Green 139, LEED 2009 LEED V4, CHPS Certified.
 - a. Benjamin Moore; Ultra Spec 500 Interior Latex Eggshell N538.
- C. Gypsum Drywall Walls: Semi-gloss, acrylic finish.
 - 1. Prime Coat: Latex-based, interior primer; MPI # 50, X-Green 50, 149, X-Green 149, LEED 2009, LEED V4, CHPS Certified.
 - a. Benjamin Moore; Ultra Spec 500 Interior Latex Primer N534
 - 2. Intermediate Coat and Topcoat: Semigloss acrylic-latex, interior enamel; MPI # 43, X-Green 43, 146, X-Green 146, 140, X-Green 140, LEED 2009, LEED V4, CHPS Certified.
 - a. Benjamin Moore; Ultra Spec 500 Latex Semigloss N539.
- D. Gypsum Drywall Walls at Bathrooms and Janitor's Closets (and where scheduled): Semi-Gloss, waterborne acrylic epoxy finish.
 - 1. Prime Coat: Latex or two component epoxy-based, interior primer; MPI # 6, 17, X-Green 17, 39, 137, X-Green 137, LEED Credit, CHPS Certified.
 - a. Benjamin Moore; Fresh Start Multi-Purpose Primer N023.

2. Intermediate Coat and Topcoat: Two component semi-gloss acrylic-epoxy; Interior/Exterior Epoxy (water based), LEED 2009.
 - a. Benjamin Moore; Corotech Pre-Catalyzed Waterborne Epoxy Semi-Gloss V341.
- E. Hollow Metal Doors, Frames, and Sidelights, and Ferrous Metals: Semigloss, acrylic-enamel finish.
1. Prime Coat: Rust-Inhibitive Primer (Water Based), MPI #107, X-Green 107, 134, LEED 2009, CHPS Certified.
 - a. Benjamin Moore; Super Spec HP Acrylic Metal Primer P04.
 2. Intermediate Coat and Topcoat: Factory-formulated semigloss acrylic-latex enamel for interior application; MPI # 141, X-Green 141, 153, X-Green 153, LEED 2009, LEED V4.
 - a. Benjamin Moore; Ultra Spec HP D.T.M. Acrylic Semi-Gloss Enamel, HP29
- F. Exposed Structural Steel Coated with Intumescent Fireproofing: Semigloss, acrylic-enamel finish. Note: Paint must be compatible with intumescent coating and must be approved by the intumescent fireproofing manufacturer for topcoating their product
1. Topcoat: Factory-formulated semigloss acrylic-latex enamel for interior application; MPI # 141, X-Green 141, 153, X-Green 153, LEED 2009, LEED V4.
 - a. Benjamin Moore; Ultra Spec HP D.T.M. Acrylic Semi-Gloss Enamel, HP29
- G. Concrete Masonry Units (CMU): Alkyd, water-based finish; in sheen as selected by Architect.
1. Prime Coat/Block Filler: MPI # 4, X-Green 4, LEED 2009, LEED V4, CHPS Certified.
 - a. Benjamin Moore Super Spec Masonry Interior/Exterior Hi-Build Block Filler 206.
 2. Intermediate Coat and Topcoat: Alkyd, water-based finish; LEED 2009, LEED V4, CHPS Certified. One of the following:
 - a. Satin: Benjamin Moore Advance Waterborne Interior Alkyd Satin 792.
 - b. Semi-Gloss: Benjamin Moore Advance Waterborne Interior Alkyd Semi-Gloss 793.
 - c. High Gloss: Benjamin Moore Advance Waterborne Interior Alkyd Gloss 794.
- H. Concrete Masonry Units (CMU) at Bathrooms and Janitor's Closets (and where scheduled): Semi-Gloss, waterborne acrylic epoxy finish.
1. Prime Coat: Acrylic block filler primer; LEED 2009.
 - a. Benjamin Moore; Corotech Acrylic Block Filler V114..
 2. Intermediate Coat and Topcoat: Two component semi-gloss acrylic-epoxy; Interior/Exterior Epoxy (water based), LEED 2009.

- a. Benjamin Moore; Corotech Pre-Catalyzed Waterborne Epoxy Semi-Gloss V341
- I. Painted Woodwork: Semigloss, acrylic finish.
 1. Prime Coat: Latex-based, interior primer; MPI # 50, X-Green 50, 149, X-Green 149, LEED 2009, LEED V4, CHPS Certified.
 - a. Benjamin Moore; Ultra Spec 500 Interior Latex Primer N534
 2. Intermediate Coat and Topcoat: Semigloss acrylic-latex, interior enamel; MPI # 43, X-Green 43, 146, X-Green 146, 140, X-Green 140, LEED 2009, LEED V4, CHPS Certified.
 - a. Benjamin Moore; Ultra Spec 500 Latex Semigloss N539.
 - J. Stained Wood and Woodwork: Satin, waterborne clear acrylic urethane over stain.
 1. Stain Coat: Penetrating wood stain, water-based; MPI # 186 LEED Credit.
 - a. Lenmar (Benjamin Moore); Waterborne Interior Wiping Stain 1WB.1300 (240 g/L)
 2. Intermediate Coat and Topcoat: Satin, interior waterborne clear acrylic urethane varnish; MPI # 121, 128.
 - a. Lenmar (Benjamin Moore); Waterborne Aqua-Plastic Urethane Satin, 1WB.1427 (335 g/L)
 - K. Natural-Finish Wood and Woodwork: Satin, waterborne clear acrylic urethane.
 1. Three Finish Coats: Satin, interior waterborne clear acrylic urethane varnish; MPI # 121, 128.
 - a. Lenmar (Benjamin Moore); Waterborne Aqua-Plastic Urethane Satin, 1WB.1427 (335 g/L).
 - L. Metal Decking and Framing Exposed at Ceilings: Flat dryfall finish.
 1. Prime Coat: Benjamin Moore; Corotech Prep All Universal Metal Primer V132.
 2. Top Coat: Benjamin Moore; Coronado Super Kote 5000 Dry Fall Alkyd Flat 105, MPI # 55.
 - M. Tectum Ceilings: Flat dryfall finish. Prime if required by manufacturer.
 1. First and Second Coat: Benjamin Moore; Coronado Super Kote 5000 Dry Fall Alkyd Flat 105, MPI # 55.
 - N. Concrete Floors: Semigloss, waterborne epoxy Polyamide self-priming finish - VOC Range <250; with slip resistant additive.
 1. Intermediate Coat and Topcoat: Benjamin Moore; I.M.C. Acrylic Epoxy Gloss #M43/M44. Applied at a dry film thickness of not less than 1.5 mils (0.038 mm).
 2. Additive: H&C Sharkgrip Slip Resistant Additive, or equal.

- O. Concrete Floors, Stained: Waterborne acrylic stain; apply one coat or two coats as directed by Architect based on mock-up approval. (one coat is more transparent, two coats is opaque)
 - 1. First Coat: Insul-X (Benjamin Moore) TuffCrete Waterborne Acrylic Concrete Stain CST-2000 (153 g/L), MPI # 58.
 - 2. Second Coat (If required): Insul-X (Benjamin Moore) TuffCrete Waterborne Acrylic Concrete Stain CST-2000 (153 g/L), MPI # 58.

END OF SECTION 099100

PAINT COLORS. IF SUBSTITUTED DRAWDOWNS WITH THE CLOSEST MATCH TO BE SUBMITTED FOR REVIEW.

TAG	GENERAL LOCATION	COLOR NO.	COLOR NAME	COMMENTS
P1	WALLS THROUGHOUT	SW7056	RESERVED WHITE	BASE COLOR EVERYWHERE BUT COMMUNITY WING ROOMS, ART ROOM, & MAKERSPACE.
P2	HM DOOR FRAMES	SW7649	SILVERPLATE	
P3	SOFFITS, GWB CEILINGS	SW7007 - CEILING BRIGHT WHITE		NOT AT CLASSROOM ENTRY NICHE, MULTI-USER TOILET ROOMS OR CORRIDOR NOOKS, EXTERIOR SOFFIT EIFS
P4	<u>DARK ACCENTS</u>			CLASSROOM ENTRY CEILINGS, CORRIDOR NICHE,
P4a	FIRST FLOOR	SW6906	LEMON TWIST	FIRST FLOOR
P4b	SECOND FLOOR	SW6711	PARAKEET	SECOND FLOOR
P4c	THIRD FLOOR	SW9048	SURFIN'	THIRD FLOOR
P4d	FOURTH FLOOR	SW6804	DIGNITY BLUE	FOURTH FLOOR, LOCKER ROOMS
P5	<u>LIGHT ACCENTS</u>			CLASSROOM ACCENT WALLS, MULTIUSER TOILET ROOM CEILINGS, STAIRWELL ACCENTS
P5a	PREK, K SINGLE USER TOILET ROOMS WALLS	SW1666	VENETIAN YELLOW	
P5b	2ND FLOOR	SW9031	PRIMAVERA	ALSO IN ART ROOM & MAKERSPACE
P5c	3RD FLOOR	SW6779	LIQUID BLUE	ALSO IN ART ROOM & LIBRARY
P5d	4TH FLOOR	SW7071	GRAY SCREEN	
P5e	SINGLE USER GENDER NEUTRAL	SW9055	BILLOWY BREEZE	
P6	STRIPE @ COMMUNITY WING	SW6683	BEE	
P7	COMMUNITY WING	SW7004	SNOWBOUND	BASE COLOR FOR ALL ROOMS IN COMMUNITY WING AS WELL AS ART ROOM & MAKERSPACE
P8	OFFICE ACCENT 1	SW9053	AQUA FRIA	FAULTY ROOM, COPY ROOM, & HEALTH SUITE
P9	OFFICE ACCENT 2	SW6521	NOTABLE HUE	MAIN OFFICE, PRINCIPAL SECRETARY OFFICE, & CONFERENCE ROOM
P10	STEEL STAIR B BEAM ONLY VISABLE FROM OUTSIDE			
P10a	LOWEST BEAM	SW6717	LIME RICKEY	
P10b	MIDDLE BEAM	SW6794	FLYWAY	
P10c	UPPER BEAM	SW6959	BLUE CHIP	
P11	LIBRARY ACCENT	SW 6695	MIDDAY	
P12	LIBRARY WALLS	SW7628	WINDFRESH WHITE	
P13	DOWNSPOUT PAINT COLOR	TBD		
P14	EXTERIOR PIPE RAIL	SW7068	GRIZZLE GREY	
P15	EIFS ROOF AREA	SW7017	DORIAN GRAY	
P16	CONCRETE FLOOR	SW7650	ELLIE GRAY	LOADING DOCK
P17	STAIR STRINGER	SW6256	SERIOUS GRAY	INC.UNDERSIDE, BUT NOT AT GWB
P18-20	open colors TBD			
	plus black and white			

SECTION 101000 - VISUAL DISPLAY SURFACES

PART 1 - GENERAL

1.1 SUMMARY

- A. This Section includes the following types of visual display boards:
 - 1. Porcelain enamel markerboards.
 - 2. Cork tackboards
 - 3. Sliding whiteboards on track system with hanging hardware.
 - 4. Magnetic boards.
- B. Related Work Specified Elsewhere:
 - 1. Sliding whiteboard doors for Makerspace and Learning Commons are specified in Division 06 Section "Interior Architectural Woodwork."

1.2 SUBMITTALS

- A. Product Data: Provide manufacturer's product data for each type of visual display board specified.
- B. Shop Drawings: For each type of visual display board required, including dimensioned elevations. Show location of joints between individual panels where unit dimensions exceed maximum panel length. Include sections of typical trim members. Show anchors, grounds, reinforcement, accessories, layout, and installation details.
- C. Samples for initial selection purposes in form of manufacturer's color charts showing full range of colors available for tackboards.
- D. Samples for Verification: Of the following products, showing color and texture or finish selected. Where finishes involve normal color and texture variations, include Sample sets showing the full range of variations expected. Prepare Samples from the same material to be used for the Work.
 - 1. Markerboards: Actual sections of porcelain enamel finish for each type of markerboard required not less than 8-1/2 by 11 inches, mounted on the substrate indicated for the final Work. Include a panel for each type, color, and texture required.
 - 2. Tackboards: Sample panels of actual materials to be supplied in the finished Work, not less than 8-1/2 by 11 inches (215 by 280 mm), mounted on the substrate indicated for the final Work. Include a panel for each type, color, and texture required.
 - 3. Magnetic Boards: One full-size sample of finishes magnetic board, which upon approval may be used in the Work.

1.3 QUALITY ASSURANCE

- A. Source Limitations: Obtain visual display boards through one source from a single manufacturer.
- B. Fire-Test-Response Characteristics: Provide materials with the surface-burning characteristics indicated, as determined by testing identical products per ASTM E 84 by UL or another testing and inspecting agency acceptable to authorities having jurisdiction. Identify materials with appropriate markings of applicable testing and inspecting agency.
 - 1. Class A
- C. Provide GREENGUARD certified products.

1.4 PROJECT CONDITIONS

- A. Field Measurements: Verify field measurements before preparation of Shop Drawings and before fabrication to ensure proper fitting. Coordinate fabrication schedule with construction progress to avoid delaying the Work.
 - 1. Allow for trimming and fitting where taking field measurements before fabrication might delay the Work.
 - 2. Established Dimensions: Where field measurements cannot be made without delaying the Work, establish dimensions and proceed with fabricating markerboards without field measurements. Coordinate wall construction to ensure actual dimensions correspond to established dimensions.

1.5 WARRANTY

- A. General Warranty: The special porcelain enamel warranty specified in this Article shall not deprive the Owner of other rights the Owner may have under other provisions of the Contract Documents and shall be in addition to, and run concurrent with, other warranties made by the Contractor under requirements of the Contract Documents.
- B. Porcelain Enamel Warranty: Furnish the manufacturer's written warranty, agreeing to replace porcelain enamel markerboards that do not retain their original writing and erasing qualities, become slick and shiny, or exhibit crazing, cracking, or flaking, provided the manufacturer's instructions with regard to handling, installation, protection, and maintenance have been followed.
 - 1. Warranty Period: 50 years.

PART 2 - PRODUCTS

2.1 MANUFACTURERS

- A. Available Manufacturers: Subject to compliance with requirements, manufacturers offering products that may be incorporated into the Work include, but are not limited to, the following:
1. Porcelain Enamel Markerboards:
 - a. Claridge Products and Equipment, Inc.
 - b. Greensteel, Inc.
 - c. Lemco, Inc.
 2. Tackboards:
 - a. Best-Rite Chalkboard Co.
 - b. Carolina Chalkboard Co.
 - c. Claridge Products and Equipment, Inc.
 - d. Ghent Manufacturing, Inc.
 - e. Greensteel, Inc.
 - f. Lemco, Inc.
 - g. Marsh Chalkboard Company.
 3. Sliding Whiteboards on Track System with Hanging Hardware: Track Technology Systems Inc.
 4. Magnetic Boards: Hale Manufacturing or Media Technologies.

2.2 MATERIALS, GENERAL

- A. Low-Emitting Materials: All composite wood, engineered wood, or agrifiber products (e.g., plywood, particleboard, medium density fiberboard) shall contain no added urea-formaldehyde resins. Laminating adhesives used to fabricate on-site and shop-applied composite wood and agrifiber assemblies shall contain no added urea-formaldehyde resins. Acceptable resins and binders include, but are not limited to, phenol formaldehyde and methyl diisocyanate (MDI)
- B. VOC Limits for Installation Adhesives and Glues: Use installation adhesives that comply with the following limits for VOC content when calculated according to 40 CFR 59, Subpart D (EPA Method 24):
1. Wood Glues: 30 g/L.
 2. Contact Adhesive: 80 g/L

2.3 TACKBOARDS

- A. Cork Tackboards: Color impregnated cork board composed of 1/4" thick self-healing, burlap backed cork laminated to a 1/4" hardboard backing, surrounded by 5/8" wide aluminum face trim.
1. Color(s): As selected by Architect for each location.
 2. Size(s): As indicated on Drawings. Refer to Tackboard and Whiteboard Schedule.
 3. Frame Style: 5/8" face, mitered corners, clear satin anodized aluminum finish.
 4. Corkboard Material: Claridge Cork
 5. Basis of Design Product: 800 Series Type CO by Claridge or equal.

2.4 MARKERBOARDS, FIXED

- A. Porcelain Enamel Markerboards: Provide balanced, high-pressure-laminated porcelain enamel boards of 3-ply construction consisting of face sheet, core material, and backing.
- B. Face Sheet: 0.024-inch (0.61-mm) enameling grade steel especially processed for temperatures used in coating porcelain on steel. Coat exposed face and edges with a 3-coat process consisting of primer, ground coat, and color cover coat. Coat concealed face with a 2-coat process consisting of primer and ground coat. Fuse cover and ground coats to steel at manufacturer's standard firing temperatures, but not less than 1200 deg F (649 deg C).
 - 1. Cover Coat (Markerboards): Provide manufacturer's standard, light-colored, special writing surface with gloss finish intended for use with erasable dry markers.
- C. Core: Core: 3/8-inch- (9.5-mm-) thick, particleboard core material complying with requirements of ANSI A208.1, Grade 1-M-1.
- D. Backing Sheet: Backing Sheet: 0.015-inch- (0.38-mm-) thick, aluminum-sheet backing.
- E. Laminating Adhesive: Provide the manufacturer's standard moisture-resistant thermoplastic-type adhesive.
- F. Markerboard Color: #100 White.
- G. Basis of Design Product: LCS 3 Markerboard by Claridge, or equivalent.
- H. Unit Markerboards: Basis of Design is Claridge 800 Series with 5/8" Face Trim, or equal.
 - 1. Accessories: Full length marker tray and map rail with two map hooks.
 - 2. Frame Style: 5/8" face, mitered corners, clear satin anodized aluminum finish.
 - 3. Sizes: As indicated on Drawings. Refer to Tackboard and Whiteboard Schedule.

2.5 SLIDING MARKERBOARDS WITH TRACK SYSTEM AND HANGING HARDWARE

- A. Sliding Whiteboards (DB-1 and DB-2): Steel markerboards with glossy surface fabricated from 18 gauge cold rolled steel with double-formed 90 degree edges on all four sides, and glossy white surface for dry erase markers. Frameless markerboard shall have multiple horizontal steel channeled stiffeners adhered to markerboard back surface, designed to be attached to sliding track system.
 - 1. Basis of Design Product: Diversiboard MB by Track Technology Systems Inc. or equal.
 - 2. Sizes: As indicated on Drawings. Refer to Tackboard and Whiteboard Schedule
 - 3. Provide music lines on the whiteboards in the music room.
- B. Sliding Whiteboard Hardware: Provide sliding track mount, dual-track system, including tracks and rollers, carriages, connectors and rails that attach white boards, and a

mechanical brake; provide additional track sections and custom roller lengths as required for complete assembly.

1. Basis of Design Product: Diversitrack by Track Technology Systems Inc. or equal.
2. Track Length: As indicated on Drawings. Refer to Tackboard and Whiteboard Schedule.

2.6 MAGNETIC BOARDS

- A. Custom fabricate magnetic boards from DF stile/rail maple end panels with perforated metal infill in the frame. Back shall be finished and flush to the wood frame. Size 30"w x 46"h.
1. Basis of Design Product: Model #EP4630 by Hale Manufacturing, or equal product by Media Technologies.

2.7 ACCESSORIES

- A. Metal Trim and Accessories: Fabricate frames and trim of not less than 0.062-inch- (1.57-mm-) thick, extruded-aluminum alloy, size and shape as indicated, to suit type of installation. Provide straight, single-length units. Keep joints to a minimum. Miter corners to a neat, hairline closure.
1. Where size of visual display boards or other conditions require support in addition to normal trim, provide structural supports or modify trim as indicated or as selected by the Architect from manufacturer's standard structural support accessories to suit conditions indicated.
- B. Mounting Accessories: Provide angle clip hangers and mounting adhesive supplied by manufacturer.
- C. Flag Holders: Provide a flag holder accessory for each classroom.

2.8 FABRICATION

- A. Assembly: Provide factory-assembled tackboards and markerboard units in single units without joints.

2.9 FINISHES

- A. General: Comply with NAAMM "Metal Finishes Manual" for recommendations relative to application and designations of finishes.
- B. Finish designations prefixed by "AA" conform to the system established by the Aluminum Association for designating aluminum finishes.
- C. Class II Clear Anodized Finish: AA-M12C22A31 (Mechanical Finish: as fabricated, nonspecular; Chemical Finish: etched, medium matte; Anodic Coating: Class II Architectural, clear film thicker than 0.4 mil).

PART 3 - EXECUTION

3.1 EXAMINATION

- A. Examine wall surfaces, with Installer present, for compliance with requirements and other conditions affecting installation of visual display boards.
 - 1. Surfaces to receive markerboards shall be free of dirt, scaling paint, and projections or depressions that would affect smooth, finished surfaces of markerboards.
 - 2. Surfaces to receive tackboards and magnetic boards shall be dry and free of substances that would impair the bond between tackboards or magnetic boards and substrate
 - 3. Do not proceed with installation until unsatisfactory conditions have been corrected.

3.2 INSTALLATION

- A. Deliver factory-built visual display boards completely assembled in one piece without joints, where possible. If dimensions exceed panel size, provide 2 or more pieces of equal length as acceptable to the Architect. When overall dimensions require delivery in separate units, prefit components at the factory, disassemble for delivery, and make final joints at the site. Use splines at joints to maintain surface alignment.
- B. Install units in locations and at mounting heights as indicated on drawings; comply with manufacturer's installation instructions. Keep perimeter lines straight, plumb, and level. Provide grounds, clips, backing materials, adhesives, brackets, anchors, trim, and accessories necessary for a complete installation.
- C. Coordinate Project-site-assembled units with grounds, trim, and accessories. Join parts with a neat, precision fit.

3.3 ADJUST AND CLEAN

- A. Verify that accessories required for each unit have been properly installed
- B. Clean units in accordance with the manufacturer's instructions. Break in markerboards only as recommended by the manufacturer.

END OF SECTION 101000

The following additions, substitutions, or clarifications are extracted from the (5) Bid Addenda issued with this project during bidding. This insert is intended to summarize addendum information relevant to this specification section. See Bid Addenda issued by the City of Yonkers for complete contract document changes.

Bid Addendum No. 4:

Note: Power for the light for display case in Section 101200 is noted on the ceiling plan not the power plan.

SECTION 101200 - DISPLAY CASES

PART 1 - GENERAL.

1.1 SUMMARY

- A. This Section includes the following:
 - 1. Illuminated display cases, recessed.
- B. Related Sections include the following:
 - 1. Division 26 Sections for wiring and other electrical work associated with illuminated display cases.

1.2 ACTION SUBMITTALS

- A. Product Data: Include construction details, material descriptions, dimensions of individual components and profiles, and finishes for display cases.
- B. Shop Drawings: Include plans, elevations, sections, details, and attachments to other work.
 - 1. Wiring Diagrams: Power, signal, and control wiring for illuminated units
- C. Samples for Initial Selection: For units with factory-applied color finishes as follows:
 - 1. Colored cork tackpanel surface, demonstrating complete line of available colors.

1.3 QUALITY ASSURANCE

- A. Source Limitations: Obtain each type of product through one source from a single manufacturer.
- B. Product Options: Drawings indicate size, profiles, and dimensional requirements of display cases bulletin boards and are based on the specific system indicated.
 - 1. Do not modify intended aesthetic effects, as judged solely by Architect, except with Architect's approval. If modifications are proposed, submit comprehensive explanatory data to Architect for review.
- C. Fire-Test-Response Characteristics: Provide tack surface with the surface-burning characteristics indicated, as determined by testing identical products per ASTM E 84 by UL or another testing and inspecting agency acceptable to authorities having jurisdiction. Identify materials with appropriate markings of applicable testing and inspecting agency

- D. Electrical Components, Devices, and Accessories: Listed and labeled as defined in NFPA 70, Article 100, by a testing agency acceptable to authorities having jurisdiction, and marked for intended use.

1.4 PROJECT CONDITIONS

- A. Field Measurements: Verify recessed openings by field measurements before fabrication and indicate measurements on Shop Drawings.
 - 1. Established Dimensions: Where field measurements cannot be made without delaying the Work, establish opening dimensions and proceed with fabricating products without field measurements. Coordinate wall construction to ensure that actual opening dimensions correspond to established dimensions

PART 2 - PRODUCTS

2.1 MATERIALS

- A. Hardboard: AHA A135.4, tempered.
- B. Particleboard: ANSI A208.1, Grade 1-M-1, made with binder containing no urea formaldehyde.
- C. Fiberboard: ANSI A208.2, Grade MD, made with binder containing no urea formaldehyde.
- D. Cork Sheet: Color impregnated cork material calendared onto a jute backing, meeting with flame-spread index of Class B when tested according to ASTM E 84.
- E. Extruded-Aluminum Bars and Shapes: ASTM B 221, Alloy 6063.
- F. Aluminum Tubing: ASTM B 429, Alloy 6063.
- G. High-Pressure Plastic Laminate: NEMA LD 3.
- H. Clear Tempered Glass: ASTM C 1048, Kind FT, Condition A, Type I, Class 1, Quality q3, with exposed edges seamed before tempering, and 3/16" thick, unless otherwise indicated.
- I. Fasteners: Provide screws, bolts, and other fastening devices made from same material as items being fastened. Provide types, sizes, and lengths to suit installation conditions.

2.2 DISPLAY CASE

- A. Recessed, Plywood-Framed Cabinet: Factory-fabricated cabinet, with top, bottom, and sides fabricated from plywood with colored cork covered tack assembly on back inside surface, glazed doors at front, and extruded-aluminum angle trim on face to cover edge of recessed opening.

1. Frame: Aluminum 2" capping angle frame with heavy duty built-in sliding glass door track.
2. Doors: Aluminum bottom framed sliding glass door, fully frame doors at 72" or higher. Glass shall be 3/16" clear tempered glass.
3. Aluminum Finish: Clear anodized.
4. Plywood Board Sides, Returns and Backs: 3/4" thick White Maple plywood covered in 1/4" thick Forbo vinyl impregnated cork, in color selected by Architect.
5. Shelving: 3/8" thick clear tempered glass shelves with polished edges, supported on Knappe and Vogt 180-80 series standards and brackets. Provide standards mounted in rear surface for full height of display case.
6. Lighting: Recessed LED light bar, top mounted, 120V
7. Lock: Ratchet type.
8. Display Case Size: As indicated on Drawings.
9. Basis-of-Design Product: The design for display cases is based on 900 DC Series by Tablet & Ticket. Subject to compliance with requirements, provide the named product or a comparable product by one of the following:
 - a. A-1 Visual Systems.
 - b. ADP/Lemco, Inc.
 - c. Best-Rite Manufacturing.
 - d. Ghent Manufacturing Inc.
 - e. Poblocki & Sons.

2.3 FABRICATION

- A. Fabricate display cases to requirements indicated for dimensions, design, and thickness and finish of materials.
- B. Use metals and shapes of thickness and reinforcing to produce flat surfaces, free of oil canning, and to impart strength for size, design, and application indicated.
- C. Fabricate cabinets and door frames with reinforced corners, mitered to a hairline fit, with no exposed fasteners.

PART 3 - EXECUTION

3.1 EXAMINATION

- A. Examine walls, with Installer present, for compliance with requirements for installation tolerances, surface conditions of wall, and other conditions affecting performance of work.
- B. Examine roughing-in for electrical power system to verify actual locations of connections before installation of illuminated units.
- C. Examine walls and partitions for suitable framing depth where recessed units will be installed
- D. Proceed with installation only after unsatisfactory conditions have been corrected.

3.2 PREPARATION

- A. Prepare recesses for display cases as required by type and size of unit.

3.3 INSTALLATION

- A. General: Install units in locations and at mounting heights indicated on Drawings, or if not indicated, at heights indicated below. Keep perimeter lines straight, plumb, and level. Provide grounds, clips, backing materials, adhesives, brackets, anchors, trim, and accessories necessary for complete installation.

- 1. Mounting Height: Install product at heights to conform to Americans with Disabilities Act Accessibility Guidelines (ADAAG) and applicable local amendments and regulations.

- B. Recessed Display Cases: Attach units to wall framing with fasteners at not more than 16 inches o.c. Attach aluminum trim over edges of recessed display cases and conceal grounds and clips. Attach trim with fasteners at not more than 24 inches o.c..

- C. Comply with requirements in Division 26 for connecting illuminated display cases.

- D. Install display case shelving level and straight.

3.4 ADJUSTING AND CLEANING

- A. Adjust doors to operate smoothly without warp or bind and contact points meet accurately. Lubricate operating hardware as recommended by manufacturer.

- B. Touch up factory-applied finishes to restore damaged or soiled areas.

END OF SECTION 101200

SECTION 101400 - SIGNAGE

PART 1 - GENERAL

1.1 SUMMARY

A. This Section includes the following:

1. Panel signs.
2. Plaques
3. Signage accessories
4. Dimensional letters.

1.2 ACTION SUBMITTALS

A. Product Data: Include construction details, material descriptions, dimensions of individual components and profiles, and finishes for each type of sign.

B. Shop Drawings: Include plans, elevations, and large-scale sections of typical members and other components. Show mounting methods, grounds, mounting heights, layout, spacing, reinforcement, accessories, and installation details.

1. Provide message list for each sign, including large-scale details of wording, lettering, and braille layout.
2. Provide full size template of engraved plaque sign.
3. Provide full-size spacing templates for individually mounted dimensional letters and numbers

C. Samples for Initial Selection: For each type of sign material indicated that involves color selection.

1. Panel Signs: Samples of each finish type and color, on not less than 4-inch squares of plastic material, showing the full range of colors available

D. Samples for Verification: For each type of sign, include the following Samples to verify color selected:

1. Panel Signs: Full-size Samples of each type of sign required.
2. Dimensional Letters and Symbols: Provide full-size representative samples of each dimensional letter type and symbol required, showing letter style, color, and material finish and method of attachment
3. Approved samples will be returned for installation into Project.

1.3 INFORMATIONAL SUBMITTALS

A. Qualification Data: For Installer.

- B. Maintenance Data: For signage cleaning and maintenance requirements to include in maintenance manuals.

1.4 QUALITY ASSURANCE

- A. Installer Qualifications: An employer of workers trained and approved by signage manufacturer.
- B. Source Limitations: Obtain each sign type through one source from a single manufacturer.
- C. Regulatory Requirements: Comply with ANSI A.117.1 - 2017 and with code provisions as adopted by authorities having jurisdiction.
 - 1. Interior Code Signage: Provide signage as required by accessibility regulations and requirements of authorities having jurisdiction. These include, but are not limited to, the following:
 - a. Room Capacity.
 - b. Elevator Signs.
 - c. Stairway Identification.
 - d. Signs for Accessible Spaces.

1.5 COORDINATION

- A. For signs supported by or anchored to permanent construction, advise installers of anchorage devices about specific requirements for placement of anchorage devices and similar items to be used for attaching signs.
 - 1. For signs supported by or anchored to permanent construction, furnish templates for installation of anchorage devices.

PART 2 - PRODUCTS

2.1 MANUFACTURERS

- A. Available Manufacturers: Subject to compliance with requirements, manufacturers offering products that may be incorporated in the Work include, but are not limited to, the following:
 - 1. Manufacturers of Panel Signs: Crown Sign Systems.
 - 2. Manufacturers of Plaques:
 - a. Advance Corporation; Braille-Tac Division.
 - b. A. R. K. Ramos.
 - c. Gemini Incorporated.
 - d. Matthews International Corporation; Bronze Division.
 - e. Metal Arts; Div. of L&H Mfg. Co.
 - f. Mills Manufacturing Company.
 - g. Nelson-Harkins Industries.

- h. Southwell Company (The).
3. Manufacturers of Dimensional Letters and Symbols:
- a. Advance Corporation; Braille-Tac Division.
 - b. A. R. K. Ramos.
 - c. ASI-Modulex, Inc.
 - d. Gemini Incorporated.
 - e. Innerface Sign Systems, Inc.
 - f. Metal Arts; Div. of L&H Mfg. Co.
 - g. Mills Manufacturing Company.
 - h. Mohawk Sign Systems.
 - i. Nelson-Harkins Industries.
 - j. Southwell Company (The).

2.2 PANEL SIGNS

- A. General: Provide signs that comply with requirements indicated for materials, thicknesses, finishes, colors, designs, shapes, sizes, and details of construction.
- 1. Produce sign surfaces constructed to remain flat under installed conditions within tolerance of plus or minus 1/16 inch (1.5 mm) measured diagonally.
 - 2. Sign materials shall meet a Class A finish.
- B. Interior Panel Signs: Provide lettering, graphics and background materials in styles and colors to match those specified on Drawings, and below. .
- 1. Produce smooth, even, level sign surfaces, constructed to remain flat under installed conditions within a tolerance of plus or minus 1/16 inch (1.58 mm) measured diagonally.
 - 2. Lettering and Braille Content: Provide uppercase letters raised 1/32 inch (.79 mm), and grade 2 braille for each specific location. Minimum text height: 5/8 inch (15.8 mm).
 - 3. Pictograms: Provide graphics raised 1/32 inch (.79 mm), with minimum 6 inch (152.4 mm) high background field, and lettering and braille written description directly below.
 - 4. Basis of Design Products: Crown Sign Systems Snap Lock Insert
 - 5. Typical Signage Type A through L:
 - a. Insert Background: 1/16" acrylic
 - b. Text: 1/32" applied acrylic
 - c. Frame: Plastic
 - d. Sign Mounting: Tape and screws
 - e. Colors:
 - 1) All frames shall be a light grey matching paint color - Sherwin Williams Ellie Gray SW7650
 - 2) Symbols and font shall be custom color to match floor color
 - 3) Inserts for Type A and B signs shall be custom color to match floor color combined with maple laminate as indicated on Drawings.
 - 4) Maple laminate for all signs shall be Wilsonart "Kensington Maple" 10776-60

- 5) Paint colors in School Building shall match:
 - a) First floor-SW6906 Lemon Twist
 - b) Second Floor- SW6711 Parakeet
 - c) Third Floor-SW9048 Surfin'
 - d) Fourth floor- SW6804 Dignity Blue
 - 6) Paint Color in Community Building: SW6804 Dignity Blue
6. Type W Directional Signage:
 - a. Insert Background: 1/16" acrylic
 - b. Text Subsurface: Engraved and paint filled
 - c. Frame: Plastic
 7. Directional maps shall have graphics of floor plan taken off the Contract Documents.
 8. Provide specified signage as scheduled.

2.3 PANEL ACCESSORIES

A. Mounting Methods:

1. Two-Face Tape: Manufacturer's standard high-bond, foam-core tape, 0.045 inch (1.14 mm) thick, with adhesive on both sides; 3M "VHB Heavy Duty Mounting Tape" or equal.
2. Adhesive: As recommended by sign manufacturer.
3. Mechanical Fasteners: Stainless steel screws.

2.4 PLAQUES

A. Cast Plaques: Provide cast metal plaque, as follows:

1. Plaque Material: Bronze.
2. Edge Style: Single line border.
3. Mounting: Concealed studs for projected mounting on substrate.
4. Thickness: 3/4" thick.
5. Finish: Leatherette with brushed surface.
6. Color: 1315 Dark Oxide polished. with satin clear coat.
7. Copy, Size and Shape: Raised copy, Arial font, and as indicated on Drawings.

2.5 DIMENSIONAL LETTERS AND SYMBOLS

A. Metal Cutout Characters: Characters with uniform faces; square-cut, smooth edges; precisely formed lines and profiles. Comply with the following requirements.

1. Material: Sheet or plate stainless.
2. Thickness:
 - a. Wall Mounted: 1 inch thick.
 - b. Canopy Mounted: 1/2" deep

3. Finish: #4 directional satin finish
 4. Height:
 - a. Wall mounted: 12".
 - b. Canopy mounted: 8"
 5. Lettering Style/Font: As indicated on Drawings
 6. Lettering Content: COMMUNITY SCHOOL 35
 7. Mounting:
 - a. Wall Mounted: Pin mounted, flush to wall surface.
 - b. Canopy Surface: Attached to 1/8" extruded aluminum canopy fascia with concealed fasteners. Bottom 2" of the canopy may not be penetrated
- B. Acrylic Cutout Characters: Characters with uniform faces; square-cut, smooth edges; precisely formed lines and profiles. Comply with the following requirements.
1. Material: Integral colored acrylic.
 2. Thickness: 1 inch thick.
 3. Color: As selected by the Architect for each location.
 4. Height: As indicated on Drawings for each location.
 5. Lettering Style/Font: As indicated on Drawings
 6. Lettering Content: Numerals as indicated on Drawings, and corresponding to the room number.
 7. Mounting: Pin mounted, flush to wall surface.
- C. Anchors and Inserts: Use toothed steel or lead expansion bolt devices for drilled-in-place anchors. Furnish inserts, as required, to be set into concrete or masonry work.

PART 3 - EXECUTION

3.1 EXAMINATION

- A. Examine substrates, areas, and conditions, with Installer present, for compliance with requirements for installation tolerances and other conditions affecting performance of work.
- B. Verify that items, including anchor inserts, provided under other sections of Work are sized and located to accommodate signs.
- C. Examine supporting members to ensure that surfaces are at elevations indicated or required to comply with authorities having jurisdiction and are free from dirt and other deleterious matter.
- D. Proceed with installation only after unsatisfactory conditions have been corrected.

3.2 INSTALLATION

- A. General: Locate interior wall signs and accessories where indicated, in accordance with ANSI A.117.1 - 2017 and with code provisions as adopted by authorities having jurisdiction, using mounting methods of the type described and in compliance with the manufacturer's instructions.
 - 1. Install signs level, plumb, and at the height indicated, with sign surfaces free from distortion or other defects in appearance.
 - 2. Mount signs on wall adjacent to the latch side of door, unless otherwise indicated. Where there is no wall space to the latch side of the door, including at double leaf doors, mount sign on the nearest adjacent wall as approved by the Architect. Mount signs at 48-inches (1219 mm) from the baseline of the lowest characters to the finished floor.
 - 3. Locate signs to allow approach within 3-inches (75 mm) of sign without encountering protruding objects or standing within swing of door.
- B. Wall-Mounted Panel Signs and Directories: Attach signs to wall surfaces using methods indicated below:
 - 1. Mechanical Fasteners: Use nonremovable mechanical fasteners placed through predrilled holes. Attach signs with fasteners and anchors suitable for secure attachment to substrate as recommended in writing by sign manufacturer.
- C. Glass-Mounted Panel Signs: Provide backer panel that matches color and size of panel sign and adhere to glass surface. Mount panel signs to backer panel using self-adhesive methods.
- D. Dimensional Letters and Symbols: Mount letters and symbols using standard fastening methods recommended by the manufacturer for letter form, type of mounting, mounting substrate, and condition of exposure indicated. Provide heavy paper template to establish letter spacing and to locate holes for fasteners

3.3 CLEANING AND PROTECTION

- A. After installation, clean soiled sign surfaces according to manufacturer's written instructions. Protect signs from damage until acceptance by Owner.

3.4 INTERIOR SIGN SCHEDULE

- A. Provide signage as indicated and scheduled on Drawings.
- B. Coordinate with Architect for occupancy capacity numbers to include on signage

END OF SECTION 101400

SECTION 102113 - TOILET COMPARTMENTS

PART 1 - GENERAL

1.1 SUMMARY

- A. This Section includes solid-plastic polymer resin units as follows:
 - 1. Toilet Enclosures: Floor-mounted, overhead braced.
 - 2. Urinal Screens: Wall hung
- B. Related Requirements:
 - 1. Section 102800 "Toilet and Bath Accessories" for toilet tissue dispensers, grab bars, and similar accessories mounted on toilet compartments.

1.2 ACTION SUBMITTALS

- A. Product data for each type and style of toilet compartment and screen specified. Include details of construction relative to materials, fabrication, and installation. Include details of anchors, hardware, and fastenings.
- B. Shop drawings for fabrication and erection of toilet compartment assemblies not fully described by product drawings, templates, and instructions for installation of anchorage devices built into other work.
 - 1. Show locations of reinforcement and cutouts for compartment-mounted toilet accessories.
- C. Samples for Verification: Of each type of color and finish required for units, prepared on 6-inch- (150-mm-) square samples of same thickness and material indicated for Work

1.3 QUALITY ASSURANCE

- A. Coordination: Furnish inserts and anchorages which must be built into other work for installation of toilet compartments and related items. Coordinate delivery with other work to avoid delay.
- B. Fire-Test-Response Characteristics: Provide toilet compartment materials with surface-burning characteristics as indicated below, as determined by testing identical to those required in this Section, per ASTM E 84, by a testing and inspecting agency acceptable to authorities having jurisdiction. Identify toilet compartments with appropriate markings of applicable testing and inspecting agency.
 - 1. Flame Spread: 200 or less.
 - 2. Smoke Developed: Less than 450, or Smoke Density: less than 75 per ASTM D 2843

- C. Flammability of Self-Supporting Plastics: 1.2 inches (30.5-mm) per minute or less per ASTM D 635.
- D. Ignition Properties of Plastic: Not less than 650 Deg. F (343.3 Deg. C) per ASTM D 1929.

1.4 PROJECT CONDITIONS

- A. Field Measurements: Verify dimensions in areas of installation by field measurements before fabrication and indicate measurements on Shop Drawings. Coordinate fabrication schedule with construction progress to avoid delaying the Work.

1.5 WARRANTY

- A. Warranty shall not deprive the Owner of other rights or remedies that the Owner may have under other provisions of the Contract Documents and is in addition to and runs concurrent with other warranties made by the Contractor under requirements of the Contract Documents.
- B. Provide a manufacturer's warranty covering the material and workmanship for a period of ten years from the date of final acceptance.
- C. Repair or replace any part which becomes defective or breaks during the warranty period.

PART 2 - PRODUCTS

2.1 MANUFACTURERS

- A. Available Manufacturers: Subject to compliance with requirements, manufacturers offering products that may be incorporated into the Work include, but are not limited to, the following:
 - 1. ASI Accurate Partitions
 - 2. Bradley
 - 3. General Partitions Mfg. Corp.
 - 4. Global Partitions
 - 5. Metpar Corp.
 - 6. Scranton Products (Santana/Comtec/Capital)

2.2 MATERIALS

- A. General: Provide materials which have been selected for surface flatness and smoothness. Exposed surfaces which exhibit pitting, seam marks, roller marks, stains, discolorations, telegraphing of core material, or other imperfections on finished units are not acceptable.
- B. Solid-Plastic, Polymer Resin: High-density polyethylene (HDPE) with homogenous color throughout. Provide material not less than 1 inch (25 mm) thick with seamless construction and eased edges in color and pattern as follows:

1. Texture: Pebble grained.
 2. Color: Blue 9509.
 3. Basis of Design Product: HDPE Solid Plastic Partitions by ASI Accurate Partitions, or equal.
- C. Pilaster Shoes and Sleeves (Caps): ASTM A 666, Type 302 or 304 stainless steel, not less than 0.0312 inch (0.8 mm) thick and 3 inches (75 mm) high, finished to match hardware.
- D. Full-Height (Continuous) Brackets: Manufacturer's standard design for attaching panels and screens to walls and pilasters of the following material:
1. Material: Clear-anodized aluminum.
- E. Hardware and Accessories: Manufacturer's standard design, heavy-duty operating hardware and accessories of the following material:
1. Material: Stainless steel.
- F. Overhead Bracing: Manufacturer's standard continuous, extruded-aluminum head rail with antigrip profile in manufacturer's standard finish.
- G. Heat-Sink Strip: Manufacturer's standard continuous, extruded-aluminum strip fastened to exposed bottom edges of solid-polymer components to prevent burning .
- H. Anchorages and Fasteners: Manufacturer's standard exposed fasteners of stainless steel or chrome-plated steel or brass, finished to match hardware, with theft-resistant-type heads. Provide sex-type bolts for through-bolt applications. For concealed anchors, use hot-dip galvanized or other rust-resistant, protective-coated steel.

2.3 FABRICATION

- A. General: Provide standard doors, panels, screens, and pilasters fabricated for compartment system. Provide units with cutouts and drilled holes to receive compartment-mounted hardware, accessories, and grab bars, as indicated.
- B. Overhead-Braced Compartments: Provide anodized aluminum angle supports and leveling bolts at pilasters as recommended by manufacturer to suit floor conditions. Make provisions for setting and securing continuous, extruded, aluminum, antigrip, overhead bracing at top of each pilaster. Provide shoe at each pilaster to conceal supports and leveling mechanism.
- C. Screens: Attach with anchoring devices as recommended by manufacturer to suit supporting structure. Set units to provide support and to resist lateral impact.

- D. Doors: Unless otherwise indicated, provide 24-inch- (610-mm-) wide in-swinging doors for standard toilet compartments and 36-inch- (914-mm-) wide out-swinging doors with a minimum 32-inch- (813-mm-) wide clear opening for compartments indicated to be handicapped accessible.
1. Hinges: Continuous spring-loaded type fabricated from extruded aluminum with nylon separators at knuckles and stainless pivot pins, that can be adjusted to hold door open at any angle up to 90 degrees. Provide theft proof fasteners concealed under a snap-on cover.
 2. Latch and Keeper: Manufacturer's standard surface-mounted latch unit with combination rubber-faced door strike and keeper designed for emergency access. Provide units that comply with accessibility requirements of authorities having jurisdiction at compartments indicated to be handicapped accessible.
 3. Coat Hook: Manufacturer's standard combination hook and rubber-tipped bumper, sized to prevent door from hitting compartment-mounted accessories.
 4. Door Bumper: Manufacturer's standard rubber-tipped bumpers at out-swinging doors or entrance screen doors.
 5. Door Pull: Manufacturer's standard unit that complies with accessibility requirements of authorities having jurisdiction at out-swinging doors. Provide units on both sides of doors at compartments indicated to be handicapped accessible.

PART 3 - EXECUTION

3.1 EXAMINATION

- A. Examine areas and conditions, with Installer present, for compliance with requirements for fastening, support, alignment, operating clearances, and other conditions affecting performance of the Work.
1. Confirm location and adequacy of blocking and supports required for installation.
- B. Proceed with installation only after unsatisfactory conditions have been corrected.

3.2 INSTALLATION

- A. General: Comply with manufacturer's written installation instructions. Install units rigid, straight, plumb, and level. Provide clearances of not more than 1/2 inch (13 mm) between pilasters and panels and not more than 1 inch (25 mm) between panels and walls. Secure units in position with manufacturer's recommended anchoring devices.
1. Secure panels to walls and panels with continuous brackets attached to the panel. Locate wall bracket fasteners so holes for wall anchors occur in masonry or tile joints. Secure panels in position with manufacturer's recommended anchoring devices.
- B. Overhead-Braced Compartments: Secure pilasters to floor and level, plumb, and tighten installation with devices furnished. Secure overhead brace to each pilaster with not less

than two fasteners. Hang doors and adjust so that tops of doors are parallel with overhead brace when doors are in closed position.

- C. Screens: Attach with anchoring devices according to manufacturer's written instructions and to suit supporting structure. Set units level and plumb and to resist lateral impact.

3.3 ADJUST AND CLEAN

- A. Hardware Adjustment: Adjust and lubricate hardware according to manufacturer's written instructions for proper operation. Set hinges on in-swinging doors to hold open approximately 30 degrees from closed position when unlatched. Set hinges on out-swinging doors and swing doors in entrance screens to return to fully closed position.
- B. Provide final protection and maintain conditions that ensure toilet compartments and screens are without damage or deterioration at the time of Substantial Completion.

END OF SECTION 102113

The following additions, substitutions, or clarifications are extracted from the (5) Bid Addenda issued with this project during bidding. This insert is intended to summarize addendum information relevant to this specification section. See Bid Addenda issued by the City of Yonkers for complete contract document changes.

Bid Addendum No. 3:

Basis of Design product: SA4 by Modernfold. Contractor shall allow for ten (10) panels for installation width of approximately 27 feet length. Contractor responsible for coordination of structural supports and arrangement of finish spaces (walls, ceilings, etc.) with final approved partition wall assembly.

SECTION 102226 - OPERABLE PARTITIONS

PART 1 - GENERAL

1.1 SUMMARY

- A. This Section includes the following:
 - 1. Manually operated, single panel partitions.

1.2 SYSTEM PERFORMANCE REQUIREMENTS

- A. Acoustical Performance: Provide operable panel partitions tested by a qualified testing agency for the following acoustical properties according to test methods indicated:
 - 1. Sound Transmission Requirements: Operable panel partition assembly tested in a full-scale opening, 14 by 9 feet (4267 by 2743 mm), for laboratory sound transmission loss performance according to ASTM E 90, determined by ASTM E 413, and rated for not less than the STC indicated.

1.3 SUBMITTALS

- A. Product Data: Material descriptions, construction details, finishes, installation details, and operating instructions for each type of operable panel partition, component, and accessory specified. Include data on acoustical performance, surface-burning characteristics, and durability.
- B. Shop Drawings: Show location and extent of operable panel partitions. Include plans, elevations, sections, details, attachments to other construction, and accessories. Indicate dimensions; weights; conditions at openings and for storage; and required installation, storage, and operating clearances. Indicate location and installation requirements for hardware and track, and direction of travel. Show blocking to be provided by others. Include the following:
 - 1. Calculations: Calculate requirements for supporting operable panel partitions and verify capacity of carriers and track components to support loads; indicate deflection limits for partition and adjacent construction.
- C. Setting Drawings: For embedded items and cutouts required in other work, including support beam punching template.
- D. Samples for Initial Selection: Manufacturer's color charts showing the full range of colors available for units with factory-applied color finishes.
 - 1. Include similar Samples of accessories involving color selection.

- E. Samples for Verification: For each type of exposed finish required, prepared on Samples of size indicated below and of same thickness and material indicated for the Work. If finishes involve normal color and texture variations, include sample sets showing the full range of variations expected.
 - 1. Panel Face Material: Manufacturer's standard-size unit, not less than 3 inches (75 mm) square.
- F. Product Certificates: Signed by manufacturers of operable panel partitions certifying that products furnished comply with requirements.
- G. Qualification Data: For firms and persons specified in "Quality Assurance" Article to demonstrate their capabilities and experience. Include lists of completed projects with project names and addresses, names and addresses of architects and owners, and other information specified.
- H. Product Test Reports: From a qualified testing agency indicating that each operable panel partition complies with requirements, based on comprehensive testing of current products.
- I. Maintenance Data: For the following to include in maintenance manuals specified in Division 1:
 - 1. Panel face finishes and finishes for exposed trim and accessories. Include precautions for cleaning materials and methods that could be detrimental to finishes and performance.
 - 2. Seals, hardware, track, carriers, and other operating components.

1.4 QUALITY ASSURANCE

- A. Installer Qualifications: An experienced installer who is certified in writing by the operable panel partition manufacturer as qualified to install the manufacturer's partition systems for work similar in material, design, and extent to that indicated for this Project.
- B. Fire-Test-Response Characteristics: Provide operable panel partitions with the following fire-test-response characteristics, as determined by testing identical products per test method indicated below by UL or another testing and inspecting agency acceptable to authorities having jurisdiction. Identify materials with appropriate markings of applicable testing and inspecting agency.
 - 1. Surface-Burning Characteristics: As follows, per ASTM E 84:
 - a. Flame Spread: 25 or less.
 - b. Smoke Developed: 450 or less.

1.5 PROJECT CONDITIONS

- A. Field Measurements: Verify operable panel partition openings and storage arrangements by field measurements before fabrication and indicate measurements on Shop Drawings. Coordinate fabrication schedule with construction progress to avoid delaying the Work.

1. Established Dimensions: Where field measurements cannot be made without delaying the Work, establish opening and storage dimensions and proceed with fabricating operable panel partitions without field measurements. Coordinate construction to ensure that actual opening dimensions correspond to established dimensions.

1.6 WARRANTY

- A. Special Warranty: Manufacturer's standard form in which manufacturer agrees to repair or replace components of operable panel partitions that fail in materials or workmanship within specified warranty period.
 1. Failures include, but are not limited to, the following:
 - a. Faulty operation of operable panel partitions.
 - b. Deterioration of metals, metal finishes, and other materials beyond normal wear.
 2. Warranty Period: One year from date of Substantial Completion.

PART 2 - PRODUCTS

2.1 PRODUCTS AND MANUFACTURERS

- A. Basis of Design Product: Provide Acousti-Seal Encore Single Panel operable wall by Modernfold Inc., or equal product by one of the following:
 1. Hufcor Inc.
 2. Panelfold Inc.

2.2 MATERIALS

- A. Steel Frame: Steel sheet, not less than 16 gauge.
- B. Vinyl-Coated Fabric Wall Covering: Manufacturer's standard, mildew-resistant, washable, reinforced heavy-duty vinyl-coated fabric wall covering; complying with CFFA-W-101-D for type indicated; Class A.
 1. Total Weight: 30 oz. per lin. yd.
 2. Color/Pattern: As selected by Architect from manufacturer's full range.
- C. Medium-Density Fiberboard: ANSI A208.2, made with binder containing no urea formaldehyde.

2.3 OPERABLE PANEL PARTITIONS

- A. Panel Operation: Manually operated, single panelstop supported with operable floor seals and automatic top seals.

- B. Panel Construction: Provide top reinforcement as required to support panel from suspension components and provide reinforcement for hardware attachment. Fabricate panels with tight hairline joints and concealed fasteners. Fabricate panels so finished in-place partition is rigid; level; plumb; aligned, with tight joints and uniform appearance; and free of bow, warp, twist, deformation, and surface and finish irregularities.
 - 1. Panels shall be nominal 4-1/4" thick in manufacturer's standard 51" width. All panel horizontal and vertical framing elements shall be formed steel.
 - 2. Panel skin shall be 16 gauge roll-formed steel wrapping around panel edge. Panel skins shall be lock formed and welded directly to the frame for unitized construction
 - 3. Panel finish shall be reinforced vinyl, with steel markerboard work surfaces where indicated.
 - 4. Panel weight shall be 11.9 lb./sq.ft.
 - 5. Panel STC shall be 56 or better.
- C. Dimensions: Fabricate operable panel partitions, from manufacturer's standard sizes, to form an assembled system of dimensions indicated on Drawings and verified by field measurements.
- D. Trimless Edges: Fabricate exposed panel edges so finish facing wraps uninterrupted around panel, covering edge and resulting in an installed partition with facing visible on vertical panel edges, without trim, for minimal sightlines at panel-to-panel joints.
- E. Hardware: Manufacturer's standard as required to operate operable panel partition and accessories; with decorative, protective finish.

2.4 SEALS

- A. General: Provide types of acoustical seals indicated that produce operable panel partitions complying with acoustical performance requirements and the following:
 - 1. Seals made from materials and profiles that minimize sound leakage.
 - 2. Seals fitting tight at contact surfaces and sealing continuously between adjacent panels and between operable panel partition perimeter and adjacent surfaces, when operable panel partition is extended, closed, and in place.
- B. Vertical Seals: Deep-nesting, interlocking astragals of a reversible tongue-and-groove configuration mounted on each edge of panel, with continuous PVC acoustical seal.
- C. Horizontal Top Seals: Continuous-contact, extruded-PVC automatic operable seal exerting uniform constant pressure on track when extended.
- D. Horizontal Bottom Seals: PVC-faced, mechanical, retractable, constant-force-contact seal exerting uniform constant pressure on floor when extended, ensuring horizontal and vertical sealing and resisting panel movement.

1. Automatically Operated for Acoustical Panels: Extension and retraction of bottom seal automatically operated by movement of partition, with operating range not less than 4 inches (100 mm) between retracted seal and floor finish
 - a. Basis of Design Product: SA4 by Modernfold.

2.5 FINISH FACING

- A. General: Provide finish facings that comply with indicated fire-test-response characteristics and that are factory applied to operable panel partitions with appropriate backing, using mildew-resistant nonstaining adhesive as recommended by facing manufacturer's written instructions.
 1. Apply facings free from air bubbles, wrinkles, blisters, and other defects, with edges tightly butted, and with invisible seams complying with Shop Drawings for location, and with no gaps or overlaps. Horizontal butted edges or seams are not permitted. Tightly secure and conceal raw and selvage edges of facing for finished appearance.
 2. Where facings with directional or repeating patterns or directional weave are indicated, mark facing top and attach facing in same direction.
 3. Match facing pattern 72 inches (1830 mm) above finished floor.

2.6 SUSPENSION SYSTEMS

- A. Suspension Tracks: Steel with adjustable steel hanger rods for overhead support, designed for type of operation, size, and weight of operable panel partition indicated. Size track to support partition operation and storage without damage to suspension system, operable panel partitions, or adjacent construction. Limit track deflection to no more than 0.10 inch (2.5 mm) between bracket supports. Provide a continuous system of track sections and accessories to accommodate configuration and layout indicated for partition operation and storage.
 1. Basis of Design Product: #RT200 Multi-Directional Track by Modernfold or equal.
- B. Carriers: Steel trolley system as required for configuration type, size, and weight of partition and for easy operation; with steel tired ball-bearing wheels.
- C. Steel Finish: Factory-applied, corrosion-resistant, protective coating, unless otherwise indicated.

2.7 ACCESSORIES

- A. Provide dry erase marker boards on each panel. Marker boards shall be 4'-0" high by full panel width, centered horizontally on the full width of the panels with wallcovering above and below.

PART 3 - EXECUTION

3.1 EXAMINATION

- A. Examine flooring, structural support, and opening, with Installer present, for compliance with requirements for installation tolerances and other conditions affecting performance of operable panel partitions. Proceed with installation only after unsatisfactory conditions have been corrected.

3.2 INSTALLATION

- A. General: Comply with ASTM E 557, operable panel partition manufacturer's written installation instructions, Drawings, and approved Shop Drawings.
- B. Install operable panel partitions and accessories after other finishing operations, including painting, have been completed.
- C. Install panels from marked packages in numbered sequence indicated on Shop Drawings.
- D. Broken, cracked, chipped, deformed, or unmatched panels are not acceptable.

3.3 ADJUSTING

- A. Adjust operable panel partitions to operate smoothly, easily, and quietly, free from binding, warp, excessive deflection, distortion, nonalignment, misplacement, disruption, or malfunction, throughout entire operational range. Lubricate hardware and other moving parts.

3.4 CLEANING AND PROTECTION

- A. Clean soiled surfaces on completing installation of operable panel partitions, to remove dust, adhesives, and other foreign materials according to manufacturer's written instructions.
- B. Provide final protection and maintain conditions, in a manner acceptable to manufacturer and Installer, that ensure operable panel partitions are without damage or deterioration at time of Substantial Completion.
- C. Replace panels that cannot be cleaned and repaired, in a manner approved by Architect, before time of Substantial Completion.

3.5 DEMONSTRATION

- A. Engage a factory-authorized service representative to train Owner's maintenance personnel to adjust, operate, and maintain operable panel partitions.

END OF SECTION 102226

SECTION 102800 - TOILET AND BATH ACCESSORIES

PART 1 - GENERAL

1.1 SUMMARY

- A. This Section includes the following:
1. Washroom accessories.
 2. Mirrors.
 3. Baby changing station.
 4. Shower accessories
 5. Installation of Owner furnished washroom accessories

1.2 SUBMITTALS

- A. Product Data: For each type of product indicated. Include the following:
1. Construction details and dimensions.
 2. Anchoring and mounting requirements, including requirements for cutouts in other work and substrate preparation.
 3. Material and finish descriptions.
 4. Features that will be included for Project.
 5. Manufacturer's warranty.
- B. Product Schedule: Indicating types, quantities, sizes, and installation locations by room of each accessory required.
1. Identify locations using room designations indicated on Contract Drawings.
 2. Identify products using designations indicated on Contract Drawings.
- C. Maintenance Data: For toilet and bath accessories to include in maintenance manuals, including replaceable parts and service recommendations.

1.3 QUALITY ASSURANCE

- A. Source Limitations: For products listed together in the same articles in Part 2, provide products of same manufacturer unless otherwise approved by Architect.
- B. Inserts and Anchorages: Furnish accessory manufacturer's standard inserts and anchoring devices that must be set in concrete or built into masonry. Coordinate delivery with other work to avoid delay.

1.4 COORDINATION

- A. Coordinate accessory locations with other work to prevent interference with clearances required for access by people with disabilities, and for proper installation, adjustment, operation, cleaning, and servicing of accessories.
- B. Deliver inserts and anchoring devices set into concrete or masonry as required to prevent delaying the Work.

1.5 WARRANTY

- A. Special Mirror Warranty: Manufacturer's standard form in which manufacturer agrees to replace mirrors that develop visible silver spoilage defects and that fail in materials or workmanship within specified warranty period.
 - 1. Warranty Period: Fifteen (15) years from date of Substantial Completion.

PART 2 - PRODUCTS

2.1 MANUFACTURERS

- A. Basis-of-Design Products: The design for toilet accessories is based on certain named equipment. Subject to compliance with requirements, provide the named product or an equivalent product by one of the following:
 - 1. A & J Washroom Accessories, Inc.
 - 2. American Dryer, Inc.
 - 3. American Specialties, Inc.
 - 4. Bradley Corporation.
 - 5. Bobrick Washroom Equipment
 - 6. Construction Specialties Inc.

2.2 MATERIALS

- A. Stainless Steel: ASTM A 666, Type 304, 0.0312-inch (0.8-mm) (22-gage) minimum nominal thickness, unless otherwise indicated.
- B. Steel Sheet: ASTM A 1008/A 1008M, Designation CS (cold rolled, commercial steel), 0.0359-inch (0.9-mm) (20-gage) minimum nominal thickness.
- C. Galvanized Steel Sheet: ASTM A 653/A 653M, with G60 (Z180) hot-dip zinc coating.
- D. Galvanized Steel Mounting Devices: ASTM A 153/A 153M, hot-dip galvanized after fabrication.
- E. Fasteners: Screws, bolts, and other devices of same material as accessory unit and tamper-and-theft resistant where exposed, and of galvanized steel where concealed.
- F. Chrome Plating: ASTM B 456, Service Condition Number SC 2 (moderate service).

- G. ABS Plastic: Acrylonitrile-butadiene-styrene resin formulation.

2.3 GRAB BARS

- A. Grab Bars; Stainless Steel Type: Provide grab bars with wall thickness not less than 18 gage (1.27 mm thick), concealed mounting with snap lock covers, satin finish, 1-1/2-inch (38.1 mm) clearance between wall surface and inside face of bar, outside diameter of 1-1/4 inches (32 mm).
 - 1. Basis of Design Product: Bobrick Series B-5806, or equal, in dimensions and configurations as indicated on Contract Drawings..

2.4 MIRROR UNITS

- A. Stainless Steel Framed Mirror Units: Fabricate frame from 1/2 by 1/2 by 3/8 inch channel shapes with square corners mitered, welded, and ground smooth, from satin-finished stainless. Provide shock absorbing strips and perimeter frame and for full size of back, with galvanized steel back, concealed wall hanger and theft-proof fasteners. Bobrick B-165, or approved equivalent.
 - 1. Sizes: 4'-0"w x 3'-0"h and 2'-0"w x 3'-0"h, as indicated on Drawings.

2.5 BABY CHANGING STATIONS

- A. Horizontal, Wall-Mounted Unit : Wall-mounted diaper-changing station with stainless steel exterior finish and blow-molded high-density grey polyethylene with Microban antimicrobial interior. Provide built-in liner dispenser that holds 25 KB150-99 sanitary liners. Provide reinforced full-length steel-on-steel hinge mechanism with 11-gauge steel mounting plates and mounting hardware. Provide unit with pneumatic shock-absorbing operating mechanism, and contoured changing surface with safety strap and 2 bag hooks. Unit complies with ASTM F 2285-04 Standard Consumer Safety Performance Specification for Diaper Changing Tables for Commercial Use .
 - 1. Basis of Design Product: Provide Model KB110-SSWM manufactured by Koala Kare.

2.6 SHOWER ACCESSORIES

- A. Shower Curtain Track: Extruded 6063-T5 aluminum alloy track with clear satin anodized finish designed for surface mounting to ceiling. Track shall be nominally 1-3/8"W x 3/4"H with .058" wall thickness. Provide tracks with all necessary connectors, splicing clamps, end stops and other accessories as required.
 - 1. Basis of Design Track: C/S 6062 by Construction Specialties, or equal.
 - 2. Curtain Carriers: Roller-type carriers with virgin nylon wheels and axles, metal bead chains, and metal hooks; provide one per curtain grommet.
 - a. Spool Carriers: C/S SP062 by Construction Specialties or equal.

3. Track Accessories: Provide end caps, connectors, end stops, coupling sleeves, wall brackets, and other accessories as required for secure and operational installation. Provide a quantity of carriers for 6-inch (150-mm) spacing the full length of the curtain plus 1 additional carrier
- B. Shower Curtain: Curtain fabric to be vinyl, intrinsically fire retardant, and antimicrobial. Provide C/S Sure-Check linen fabric in color selected by Architect, manufactured by CS Cubicle Curtains a division of Construction Specialties or equal. Fabricate as follows:
1. Width: Equal to track length from which curtain is hung plus 10 percent, but not less than 12 inches.
 2. Length: Equal to floor-to-ceiling height minus 2 inches from finished ceiling at top and 1 inch above finished floor.
 3. Top Hem: Not less than 1 inch and not more than 1-1/2 inches wide, triple thickness, reinforced with integral web, and double stitched.
 - a. Grommets: 2-piece, rolled-edge, rustproof, nickel-plated brass and spaced not more than 6 inches o.c.
 4. Bottom and Side Hems: Not less than 1 inch wide, reinforced, triple thickness, and single stitched.
 5. Seams: Not less than 1/2 inch wide, double turned and double stitched.
 6. Curtain Top: 20-inch- wide no. 40 nylon mesh with overlapped seams and double-lock stitching to body of curtain, and a clear vinyl window of width as selected by Architect.

2.7 OTHER WASHROOM ACCESSORIES

- A. All other washroom accessories indicated on Drawings shall be furnished by Owner. Install all Owner-furnished washroom accessories.

2.8 FABRICATION

- A. General: No names or labels are permitted on exposed faces of toilet and bath accessory units. On either interior surface not exposed to view or on back surface, provide identification of each accessory item either by a printed, waterproof label or a stamped nameplate indicating manufacturer's name and product number
- B. Surface-Mounted Toilet Accessories, General: Except where otherwise indicated, fabricate units with tight seams and joints, exposed edges rolled. Hang doors and access panels with full-length, continuous hinges. Equip units for concealed anchorage and with corrosion-resistant backing plates.
- C. Recessed Toilet Accessories, General: Except where otherwise indicated, fabricate units of all-welded construction, without mitered corners. Hang doors or access panels with full-length, stainless steel piano hinge. Provide anchorage that is fully concealed when unit is closed.
- D. Keys: Provide universal keys for internal access to accessories for servicing and resupplying. Provide minimum of six (6) keys to Owner's representative.

PART 3 - EXECUTION

3.1 INSTALLATION

- A. Install accessories according to manufacturers' written instructions, using fasteners appropriate to substrate indicated and recommended by unit manufacturer. Install units level, plumb, and firmly anchored in locations and at heights indicated.
- B. Secure mirrors to walls in tamperproof manner with special hangers, toggle bolts, or screws. Set units plumb, level, and square at locations indicated, according to manufacturer's written instructions for type of substrate involved.
- C. Grab Bars: Install to withstand a downward load of at least 250 lbf (1112 N), when tested according to method in ASTM F 446, and in compliance with ADA Regulations.
- D. Baby Changing Table: Mount to wall in accordance with manufacturer's directions to support loading capacity.
- E. Shower Curtain Track: Surface-mount curtain track on ceiling surface by fastening track through finished ceiling to steel support framing above ceiling using metal fasteners of type and at spacing recommended by manufacturer.
 - 1. Install ceiling-mounted tracks at intervals of not less than 24 inches.
 - 2. Center fastener in track to insure unencumbered carrier operation.
 - 3. Wherever possible, install curtain track in uninterrupted lengths to avoid splices.
- F. Shower Curtain: Attach curtain to hangers just prior to Substantial Completion to ensure curtain is clean and undamaged at time of Owner's acceptance of work.

3.2 ADJUSTING AND CLEANING

- A. Adjust toilet accessories for unencumbered, smooth operation. Verify that mechanisms function smoothly. Replace damaged or defective items.
- B. Remove temporary labels and protective coatings.
- C. Clean and polish exposed surfaces according to manufacturer's written recommendations after removing temporary labels and protective coatings.

END OF SECTION 102800

SECTION 102900 - MEDICAL ACCESSORIES

PART 1 - GENERAL

1.1 SUMMARY

A. This Section includes the following:

1. Medicine storage cabinet.

1.2 SUBMITTALS

A. Product Data: For each type of product indicated

B. Product Schedule: Indicating types, quantities, sizes, and installation locations by room of each accessory required.

1. Identify locations using room designations indicated on Contract Drawings.
2. Identify products using designations indicated on Contract Drawings.

C. Submit keys to cabinet with closeout submission.

1.3 WARRANTY

A. Special Warranty: Manufacturer's standard form in which manufacturer agrees to replace cabinets that exhibit defects and that fail in materials or workmanship within specified warranty period.

1. Warranty Period: Twelve (12) years from date of Substantial Completion.

PART 2 - PRODUCTS

2.1 LOCKING MEDICINE STORAGE CABINET

A. Narcotics Cabinet: Provide heavy-duty, 20 gauge painted steel cabinet with one double locking door, having the following characteristics:

1. Two Shelves: One fixed and one adjustable and removable shelf with choice of four locations
2. High security pick-resistant tubular lock with four keys. keys have unique lock sequences
3. Full length stainless steel pinned non-removable door hinge.
4. Predrilled holes in the back for mounting on a wall, cabinet or other solid surface (wall mounting hardware included).
5. Dimensions of 29.5"H x 23.5"w x 10.5"d
6. Powder coat paint finish in gloss beige.

7. Basis of Design Product: Narcotics Cabinet, Large, Standard Line, Single Door/Double Lock, #2830AQ by Harloff, or equal.

PART 3 - EXECUTION

3.1 INSTALLATION

- A. Install accessories according to manufacturers' written instructions, using fasteners appropriate to substrate indicated and recommended by unit manufacturer. Install units level, plumb, and firmly anchored in locations and at heights indicated.
- B. Secure cabinet to walls in concealed, tamperproof manner with special hangers, toggle bolts, or screws. Set units plumb, level, and square at locations indicated, according to manufacturer's written instructions for type of substrate involved.

3.2 CLEANING

- A. Remove temporary labels and protective coatings.
- B. Clean exposed surfaces according to manufacturer's written recommendations after removing temporary labels and protective coatings.

END OF SECTION 102900

SECTION 105113 - METAL LOCKERS

PART 1 - GENERAL

1.1 SUMMARY

- A. This Section includes the following:
 - 1. Wardrobe lockers, double tier and single tier, knocked-down type, including ADA compliant lockers.
 - 2. Ventilated athletic lockers, double-tier, knocked-down type, including ADA compliant lockers.
 - 3. Locker room benches, ADA compliant.

1.2 ACTION SUBMITTALS

- A. Product Data: Include construction details, material descriptions, dimensions of individual components and profiles, and finishes for each type of locker and bench.
- B. Shop Drawings: Include plans, elevations, sections, details, and attachments to other Work.
 - 1. Show locker fillers, trim, base, and accessories.
 - 2. Include locker-numbering sequence of lockers.
- C. Samples for Initial Selection: For units with factory-applied color finishes.
- D. Samples for Verification: For the following products, in manufacturer's standard sizes, showing the full range of color, texture, and pattern variations expected. Prepare Samples from the same material to be used for the Work.
 - 1. Lockers.

1.3 INFORMATIONAL SUBMITTALS

- A. Maintenance Data: For adjusting, repairing, and replacing locker doors and latching mechanisms to include in maintenance manuals specified in Division 01.
- B. Qualification Data: For qualified Installer.

1.4 QUALITY ASSURANCE

- A. Installer Qualifications: Manufacturer's authorized representative who is trained and approved for installation of units required for this Project.

- B. Source Limitations: Obtain locker units, benches and accessories through one source from a single manufacturer.
- C. Regulatory Requirements: Where metal lockers and benches are indicated to comply with accessibility requirements, comply with the U.S. Architectural & Transportation Barriers Compliance Board's "Americans with Disabilities Act (ADA) and Architectural Barriers Act (ABA) Accessibility Guidelines for Buildings and Facilities" and ICC/ANSI A117.1
- D. Lockers shall be GREENGUARD Gold Certified by UL Environment through the GREENGUARD Certification Program.

1.5 DELIVERY, STORAGE, AND HANDLING

- A. Do not deliver lockers until spaces to receive them are clean, dry, and ready for locker installation.
- B. Protect lockers from damage during delivery, handling, storage, and installation..

1.6 WARRANTY

- A. Special Warranty: Manufacturer's standard form in which manufacturer agrees to repair or replace components of metal lockers that fail in materials or workmanship, excluding finish, within specified warranty period.
 - 1. Failures include, but are not limited to, the following:
 - a. Structural failures.
 - b. Faulty operation of latches and other door hardware.
 - 2. Damage from deliberate destruction and vandalism is excluded.
 - 3. Warranty: Lifetime from date of Substantial Completion.

1.7 EXTRA MATERIALS

- A. Furnish extra materials that match products installed and that are packaged with protective covering for storage and identified with labels describing contents. Provide 5% full-size units of each of the following metal locker hardware items:
 - 1. Locks.
 - 2. Hinges
 - 3. Hooks.

PART 2 - PRODUCTS

2.1 MANUFACTURERS

- A. Available Manufacturer: Provide Basis of Design lockers and benches by Lyon or equal lockers by one of the following:

1. DeBourgh Manufacturing Co.
2. List Industries, Inc.
3. Penco

2.2 MATERIALS

- A. Cold-Rolled Steel Sheet: ASTM A 366/A 366M, matte finish, suitable for exposed applications, and stretcher leveled or roller leveled to stretcher-leveled flatness.
- B. Electrolytic Zinc-Coated Steel Sheet: ASTM A 591/A 591M, commercial quality, coating Class C; mill phosphatized; suitable for exposed applications; and stretcher leveled or roller leveled to stretcher-leveled flatness.
- C. Steel Tube: ASTM A 500, cold rolled
- D. Fasteners: Zinc- or nickel-plated steel, slotless-type exposed bolt heads, and self-locking nuts or lock washers for nuts on moving parts.
- E. Anchors: Material, type, and size required for secure anchorage to each substrate.
 1. Provide nonferrous-metal or hot-dip galvanized anchors and inserts on inside face of exterior walls, for corrosion resistance.
 2. Provide toothed-steel or lead expansion sleeves for drilled-in-place anchors.

2.3 WARDROBE AND VENTILATED (ATHLETIC) LOCKERS

- A. Basis of Design Products: Provide the following, or equal:
 1. Wardrobe Lockers in Kitchen: Heavy Duty Corridor Lockers by Lyon.
 2. Wardrobe Lockers in Corridors (Recessed) : PDQ Plus by Lyon.
 3. Athletic Lockers: Heavy Duty Ventilated Lockers by Lyon.
- B. Body: Locker body components shall be fabricated of cold rolled steel specially formed for added strength and rigidity and to ensure tight joints at fastening points, in the following thicknesses.
 1. Wardrobe Lockers: 24 gauge
 2. Ventilated (Athletic) Lockers: 16 gauge with 18 gauge backs.
 - a. Provide solid sides for ventilated lockers, not perforated.
- C. Frames: Fabricate from channel shape, not less than 16 gauge steel. Provide vertical door frame members with additional 3/8 inch (9.5 mm) flange as a continuous door strike.
- D. Doors: Fabricate doors from one piece 14 gauge sheet steel with full channel formation of adequate depth to fully conceal lock bar on lock side, channel formation on hinge side, right angle formations across top and bottom, with holes for attaching number plates.

1. Wardrobe Lockers: Provide louvered doors in manufacturer's standard louver pattern.
 2. Ventilated (Athletic) Lockers: Doors shall be punched with diamond shaped perforations.
- E. Door Jambs: Single tier lockers shall have three door jambs; double tier tier lockers shall have two jambs welded to side of door frames to engage locking device. Design and gauge of jamb shall prevent freeing of locking device by prying. Each jamb shall have easily replaceable soft rubber bumper.
- F. Hinges: Provide two inch high, 0.050" thick steel, five knuckle, double spun, full loop, tight pin hinges, projection welded to door frame and securely fastened to the door with steel rivets. Provide three hinges on single-tier locker doors over 48 inches high and two hinges on all other doors.
- G. Quiet Locking Device: Single tier locking device shall engage frame at three points; double tier at two points. Channel shaped locking device with full length reinforcing ribs shall be a quiet design utilizing nylon guide inserts to reduce metal-to-metal contact. The locking device shall include a latch finger that engages the 12-gauge door jamb. Lock bar shall be enclosed on three sides and operate within the channel formation of the door. Locking device shall be prelocking so mechanism can be locked in open position – door locking automatically when closed. Doors also to be provided with lock hole filler to permit use of a built-in lock.
- H. Die-Cast Handle: Provide recessed chrome-plated zinc alloy die-cast case and handle attached to latch bar concealed inside door and tamperproof. No moving parts are to operate against outside surface of locker. Padlock attachment to be integral part of lift, which shall be attached directly to locking bar and protected by fixed handle housing. Handle to provide built in padlock strike. The recessed handle shall be 4-1/8"w x 6-1/16"h x 1-1/4"d. Multiple tier lockers shall be equipped with a 16-gauge door pull with padlock attachment when not used with built in locks.
- I. Shelves: Single tier lockers shall have one shelf approximately 9" below top. Flanged on all four sides for strength with the front flange turned 45 degrees for safety and attached at no less than two points through each side flange. Only single tier lockers have shelves. Fabricate shelves in the following thicknesses.
1. Wardrobe Lockers: 24 gauge
 2. Ventilated (Athletic) Lockers: 16 gauge.
- J. Sizes and Configurations:
1. Corridor Lockers: Double-tier wardrobe lockers 15" w x 12"d x 72"h.
 2. Locker Room Lockers: Double-tier ventilated (athletic) lockers 15" w x 15"d x 78"h
 3. Kitchen Lockers: Single-tier wardrobe lockers 12" w x 12"d x 66"h.
- K. Configuration: Double tier and single tier.

2.4 ADA LOCKER BENCHES

- A. Provide bench units with overall assembly height of 17-1/2 inches (445 mm).
- B. Bench Tops: Manufacturer's standard one-piece units, with rounded corners and edges.
 - 1. Size: Minimum 20-inch- (508-mm-) wide by 1-1/4 inches thick.
 - 2. Laminated clear Maple with one coat of clear sealer on all surfaces and one coat of clear lacquer on top and sides.
- C. Pedestals: Provide pedestal supports, with predrilled fastener holes, complete with fasteners and anchors, and as follows:
 - 1. Type: Tubular, minimum 1-1/2-inch (38-mm) diameter, single piece heavy-duty cast iron or steel pedestal support or cast iron base not more than 6'-0" o.c., with provisions for fastening to floor and securing to bench. Provide all anchorages.
 - 2. Furnish a minimum of four pedestals for each bench, with pedestal spacing not more than 72 inches (1820 mm) o.c..
 - 3. Pedestal color as selected by Architect.

2.5 LOCKS

- A. Fabricate lockers to receive the following locking devices:
 - 1. Padlocks.

2.6 LOCKER ACCESSORIES

- A. Interior Equipment: Furnish each locker with the following items, unless otherwise indicated:
 - 1. Hooks: Manufacturer's standard zinc-plated, ball-pointed steel. Provide one double-prong ceiling hook, and three single-prong wall hooks for single-, double-, and triple-tier units. Attach hooks with at least two fasteners.
- B. Number Plates: Manufacturer's standard etched, embossed, or stamped, aluminum number plates with numerals at least 3/8 inch (9 mm) high. Number lockers in sequence indicated. Attach plates to each locker door, near top, centered, with at least two aluminum rivets.
- C. Filler Panels: Manufacturer's standard; fabricated from minimum 0.0478-inch- (1.20-mm-) thick steel sheet in an unequal leg angle shape, and finished to match lockers. Provide slip joint filler angle formed to receive filler panel.
- D. Finished End Panels: Finished to match lockers, and designed for concealing exposed ends of nonrecessed lockers.

- E. Continuous Sloping Tops: Fabricated from 0.048-inch (1.21-mm) nominal-thickness steel sheet, with a pitch of approximately 20 degrees.
 - 1. Provide for kitchen lockers and athletic lockers.
- F. Legs: 6" high, manufacturer's standard construction. Provide closed front and end bases for legs.
 - 1. Provide for kitchen lockers and athletic lockers.

2.7 FABRICATION

- A. Fabrication shall be on the unit principle, each locker with individual door and frame, individual top, bottom, back, and shelves, with common intermediate divisions separating compartments.
- B. Accessible Lockers: Fabricate as follows:
 - 1. Locate bottom shelf no lower than 15 inches (381 mm) above the floor.
 - 2. Where hooks, coat rods, or additional shelves are provided, locate no higher than 48 inches (1219 mm) above the floor.

2.8 FINISHES, GENERAL

- A. Finish all steel surfaces and accessories, except prefinished stainless-steel and chrome-plated surfaces.
- B. Comply with NAAMM's "Metal Finishes Manual for Architectural and Metal Products" for recommendations for applying and designating finishes.
- C. Protect mechanical finishes on exposed surfaces from damage by applying a strippable, temporary protective covering before shipping.
- D. Appearance of Finished Work: Variations in appearance of abutting or adjacent pieces are acceptable if they are within one-half of the range of approved Samples. Noticeable variations in the same piece are not acceptable. Variations in appearance of other components are acceptable if they are within the range of approved Samples and are assembled or installed to minimize contrast.

2.9 STEEL SHEET FINISHES

- A. Surface Preparation: Clean surfaces of dirt, oil, grease, mill scale, rust, and other contaminants that could impair paint bond. Use manufacturer's standard methods.
- B. Baked-Enamel Finish: Immediately after cleaning and pretreating, apply manufacturer's standard baked-enamel finish consisting of a thermosetting topcoat. Comply with paint manufacturer's written instructions for applying and baking to achieve a minimum dry film

thickness of 1.4 mils (0.036 mm) on doors, frames, and legs, and 1.1 mils (0.028 mm) elsewhere.

1. Color and Gloss: As follows:
 - a. Corridor Lockers: Combination alternating Brilliant Blue 500764 and Monorail Grey GY655-7S.
 - b. Locker Room Lockers: Two premier colors selected by Architect
 - c. Kitchen Lockers: One premier color selected by Architect

PART 3 - EXECUTION

3.1 EXAMINATION

- A. Examine substrate for suitable conditions where metal lockers are to be installed.
 1. Proceed with installation only after unsatisfactory conditions have been corrected.

3.2 INSTALLATION

- A. Assemble lockers in accordance with manufacturer's directions.
- B. Install metal lockers and accessories level, plumb, rigid, and flush according to manufacturer's written instructions.
- C. Anchor lockers to floors and walls at intervals recommended by manufacturer, but not more than 36 inches (910 mm) o.c. Install anchors through backup reinforcing plates where necessary to avoid metal distortion, using concealed fasteners.
- D. Fit exposed connections of trim, fillers, and closures accurately together to form tight, hairline joints, with concealed fasteners and splice plates.
- E. Attach boxed end panels with concealed fasteners to conceal exposed ends of nonrecessed lockers.
- F. Attach finished end panels with fasteners only at perimeter to conceal exposed ends of nonrecessed lockers.
- G. Attach sloping-top units to metal lockers, with closures at exposed ends.
- H. Fixed Locker Benches: Securely fasten tops of pedestals to undersides of bench tops, and anchor bases to floor.

3.3 ADJUSTING, CLEANING, AND PROTECTION

- A. Adjust doors and latches to operate easily without binding. Verify that integral locking devices operate properly.

- B. Clean interior and exposed exterior surfaces and polish stainless-steel and nonferrous-metal surfaces.
- C. Protect lockers from damage, abuse, dust, dirt, stain, or paint. Do not permit locker use during construction.
- D. Touch up marred finishes, or replace locker units that cannot be restored to factory-finished appearance. Use only materials and procedures recommended or furnished by locker manufacturer.

END OF SECTION 105113

SECTION 105200 - FIRE-PROTECTION SPECIALTIES

PART 1 - GENERAL

1.1 SUMMARY

- A. This Section includes the following:
 - 1. Portable fire extinguishers.
 - 2. Fire-protection cabinets for portable fire extinguishers.
 - 3. Fire-protection accessories.

1.2 SUBMITTALS

- A. Product Data: Include construction details, material descriptions, dimensions of individual components and profiles, and finishes for fire-protection specialties.
 - 1. Fire Extinguishers: Include rating and classification.
 - 2. Cabinets: Include roughing-in dimensions, details showing mounting methods, relationships of box and trim to surrounding construction, door hardware, cabinet type, trim style, and panel style.

1.3 QUALITY ASSURANCE

- A. Source Limitations: Obtain fire extinguishers and cabinets through one source from a single manufacturer.
- B. NFPA Compliance: Fabricate and label fire extinguishers to comply with NFPA 10, "Standard for Portable Fire Extinguishers."
- C. NYS Fire Code Compliance: Fabricate and label fire extinguishers to comply with New York State Fire Code.
- D. Fire Extinguishers: FM listed and labeled for type, rating, and classification specified.
- E. Fire-Rated Fire-Protection Cabinets: Listed and labeled to comply with requirements of ASTM E 814 for fire-resistance rating of walls where they are installed

PART 2 - PRODUCTS

2.1 MANUFACTURERS

- A. Manufacturers: Subject to compliance with requirements, provide products by one of the following:
 - 1. J.L. Industries, Inc.

2. Kidde: Walter Kidde, The Fire Extinguisher Co.
3. Larsen's Manufacturing Company.
4. Potter-Roemer; Div. of Smith Industries, Inc.

2.2 MATERIALS

- A. Cold-Rolled Steel Sheet: Carbon steel, complying with ASTM A 366/A 366M, commercial quality, stretcher leveled, temper rolled.
- B. Stainless-Steel Sheet: ASTM A 666, Type 304.

2.3 PORTABLE FIRE EXTINGUISHERS

- A. General: Provide fire extinguishers of type, size, and capacity for each fire-protection cabinet and mounting bracket indicated.
- B. Multipurpose Dry-Chemical Type: UL-rated 4-A:60-B:C, 10-lb (4.5-kg) nominal capacity, in enameled-steel container.
 1. Available Product: MP 10, Larsen's Manufacturing Company.

2.4 FIRE-PROTECTION CABINETS

- A. Basis-of-Design Product: Occult Series Model SS 2409, as manufactured by Larsen's Manufacturing Co., or an approved equivalent product by one of the following:
 1. JL Industries, Inc.
 2. Kidde Fyrnetics.
 3. Potter Roemer; Div. of Smith Industries, Inc.
- B. Cabinet Construction: Provide manufacturer's standard box (tub), with trim, frame, door, and hardware to suit cabinet type, trim style, and door style indicated. Weld joints and grind smooth. Miter and weld perimeter door frames.
 1. Fire-Rated Cabinets: Listed and labeled to meet requirements of ASTM E 814 for fire-resistance rating of wall where it is installed.
 - a. Construct fire-rated cabinets with double walls fabricated from 0.0478 inch (1.2 mm) thick, cold-rolled steel sheet lined with minimum 5/8 inch (16 mm) thick, fire-barrier material.
 - b. Provide factory-drilled mounting holes.
- C. Cabinet Size: Suitable for specified fire extinguisher.
- D. Cabinet Style: Trimless, with concealed hinge and closed door completely covering cabinet flange.

- E. Cabinet Construction: Provide manufacturer's standard box (tub), with trim, frame, door, and hardware to suit cabinet type, trim style, and door style indicated. Weld joints and grind smooth. Miter and weld perimeter door frames.
 - 1. Cabinet Material: Enameled-steel sheet.
 - 2. Recessed Cabinet: Cabinet box fully recessed in walls of depth indicated; with box flange overlapping surrounding wall surface and fully concealed by door when in closed position.

- F. Door Construction: Fabricate doors according to manufacturer's standards, of materials indicated, and coordinated with cabinet types and trim styles selected.
 - 1. Door Material: Stainless steel sheet
 - 2. Door Style: Flush, solid panel.
 - 3. Door Hardware: Ensure hardware meets ADA requirements. Provide manufacturer's built-in cylinder lock system (*Larsen-Loc™*), or approved equivalent, and door-operating hardware of proper type for cabinet type, trim style, and door material and style indicated. Provide either lever handle with cam-action latch, or exposed or concealed door pull and friction latch. Provide concealed or continuous-type hinge permitting door to open 180 degrees.
 - 4. Lettering: Provide factory applied lettering that reads "IN CASE OF FIRE ONLY - PULL FIRMLY ON HANDLE."

2.5 ACCESSORIES

- A. Mounting Brackets: Manufacturer's standard steel, designed to secure extinguisher, of sizes required for types and capacities of extinguishers indicated, with plated or baked-enamel finish. Provide brackets for extinguishers not located in cabinets.

- B. Identification: Provide lettering to comply with authorities having jurisdiction for letter style, color, size, spacing, and location. Locate as indicated by Architect.
 - 1. Identify fire extinguisher in fire protection cabinet with the words "FIRE EXTINGUISHER."
 - a. Location: Applied to cabinet door.
 - b. Application Process: Die cut.
 - c. Lettering Color and Style: As selected by Architect.

 - 2. Identify bracket-mounted extinguishers with the words "FIRE EXTINGUISHER" in red letter decals applied to wall surface.

2.6 FINISHES

- A. Comply with NAAMM's "Metal Finishes Manual for Architectural and Metal Products" for recommendations for applying and designating finishes.

- B. Protect mechanical finishes on exposed surfaces from damage by applying a strippable, temporary protective covering before shipping.

- C. Surface Preparation: Clean surfaces of dirt, oil, grease, mill scale, rust, and other contaminants that could impair paint bond using manufacturer's standard methods.
- D. Steel Finishes: Manufacturer's standard baked-enamel paint in color selected by Architect for the interior of cabinet.
- E. Stainless Steel, No. 4 finish for door and frame.

PART 3 - EXECUTION

3.1 EXAMINATION

- A. Examine roughing-in for hose valves, hose racks, and cabinets to verify actual locations of piping connections before cabinet installation.
- B. Examine walls and partitions for suitable framing depth and blocking where recessed and semirecessed cabinets are to be installed.
- C. Examine fire extinguishers for proper charging and tagging.
 - 1. Remove and replace damaged, defective, or undercharged units.
- D. Proceed with installation only after unsatisfactory conditions have been corrected.

3.2 INSTALLATION

- A. Comply with manufacturer's written instructions for installing fire-protection specialties.
- B. Install in locations and at mounting heights indicated or, if not indicated, at heights acceptable to authorities having jurisdiction.
 - 1. Prepare recesses for cabinets as required by type and size of cabinet and trim style.
 - 2. Fasten mounting brackets to structure, square and plumb.
 - 3. Fasten cabinets to structure, square and plumb.

3.3 ADJUSTING, CLEANING, AND PROTECTION

- A. Adjust cabinet doors that do not swing or operate freely.
- B. Refinish or replace cabinets and doors damaged during installation.
- C. Provide final protection and maintain conditions that ensure that cabinets and doors are without damage or deterioration at the time of Substantial Completion.

END OF SECTION 105200

SECTION 105213 - AUTOMATED EXTERNAL DEFIBRILLATOR (AED) SPECIALTIES

PART 1 - GENERAL

1.1 SUMMARY

- A. This Section includes the following:

1. Cabinets for Automated External Defibrillator (AED) unit.

1.2 SUBMITTALS

- A. Product Data: Include construction details, material descriptions, dimensions of individual components and profiles, and finishes for AED specialties.

1. Cabinets: Include roughing-in dimensions, details showing mounting methods, relationships of box and trim to surrounding construction, door hardware, cabinet type, trim style, and panel style.

1.3 QUALITY ASSURANCE

- A. Source Limitations: Obtain AED cabinets through one source from a single manufacturer.

PART 2 - PRODUCTS

2.1 MATERIALS

- A. Cold-Rolled Steel Sheet: Carbon steel, complying with ASTM A 366/A 366M, commercial quality, stretcher leveled, temper rolled.

2.2 AED CABINETS

- A. Basis-of-Design Product: 1400 Series AED Cabinet as manufactured by JL Industries, Inc. or an approved equivalent product by one of the following:

1. Allied Medical Products
2. Phillips Healthcare.
3. Physio-Control
4. ZOLL Medical.

- B. Cabinet Construction: Provide manufacturer's standard box (tub), with trim, frame, door, and hardware to suit cabinet type, trim style, and door style indicated. Weld joints and grind smooth. Miter and weld perimeter door frames.

1. Cabinet Size: Suitable for any size AED unit.
2. Cabinet Style: Exposed one-piece trim and door frame.
3. Cabinet Material: Enameled-steel sheet.

4. Semi-Recessed Cabinet: Semi-recessed cabinet partially concealed in walls, with 2-1/2" or 3" rolled edge trim overlapping wall surface.
- C. Door Construction: Fabricate doors according to manufacturer's standards, of materials indicated, and coordinated with cabinet types and trim styles selected.
1. Door Material: Enameled-steel sheet.
 2. Door Style: Full acrylic or tempered glass glazing with pull handle and AED graphics on door.
- D. Accessories: Provide the following:
1. Audible alarm 85dba, powered by 9 volt battery. Provide with on/off switch
 2. Strobe light, powered by 9 volt battery, built-in to cabinet or mounted above cabinet as required by field conditions.

2.3 FINISHES

- A. Comply with NAAMM's "Metal Finishes Manual for Architectural and Metal Products" for recommendations for applying and designating finishes.
- B. Protect mechanical finishes on exposed surfaces from damage by applying a strippable, temporary protective covering before shipping.
- C. Surface Preparation: Clean surfaces of dirt, oil, grease, mill scale, rust, and other contaminants that could impair paint bond using manufacturer's standard methods.
- D. Steel Finishes: Manufacturer's standard baked-enamel paint in color selected by Architect.

PART 3 - EXECUTION

3.1 EXAMINATION

- A. Examine walls and partitions for suitable framing depth and blocking where recessed and semirecessed cabinets are to be installed.
- B. Proceed with installation only after unsatisfactory conditions have been corrected.

3.2 INSTALLATION

- A. Comply with manufacturer's written instructions for installing AED specialties.
- B. Install in locations and at mounting heights indicated or, if not indicated, at heights acceptable to authorities having jurisdiction.
 1. Prepare recesses for cabinets as required by type and size of cabinet and trim style.
 2. Fasten cabinets to structure, square and plumb.

3.3 ADJUSTING, CLEANING, AND PROTECTION

- A. Adjust cabinet doors that do not swing or operate freely.
- B. Refinish or replace cabinets and doors damaged during installation.
- C. Provide final protection and maintain conditions that ensure that cabinets and doors are without damage or deterioration at the time of Substantial Completion.

END OF SECTION 105213

SECTION 105316 - CANOPIES

PART 1 - GENERAL

1.1 SUMMARY

A. This Section includes the following:

1. Fixed metal canopies.

B. Related Sections include the following:

1. Division 05 Section "Metal Fabrications" for blocking, shims, reinforcing, and supplemental support members for connecting to canopy frame and anchorage.
2. Division 06 Section "Miscellaneous Carpentry" for blocking, nailers, shims, reinforcing, framing, and furring for connecting to canopy frame and anchorage.

1.2 PERFORMANCE REQUIREMENTS

A. General: Design, fabricate, and install canopies to withstand loads from gravity, wind, snow, ponding, drift and structural movement, including thermally induced movement; and to resist, without failure, other conditions of in-service use, including exposure to weather.

B. Structural Performance: Provide canopies capable of withstanding the effects of gravity loads and the following loads and stresses within limits and under conditions indicated:

1. Wind Loads: Determine loads based on the minimum design wind pressures indicated on drawings.
2. Snow Loads: Determine loads based on the minimum design snow loads indicated on drawings.

C. Thermal Movements: Provide canopies that allow for thermal movements resulting from the following maximum change (range) in ambient and surface temperatures by preventing buckling, opening of joints, overstressing of components, failure of connections, tearing of fabric, and other detrimental effects. Base engineering calculation on surface temperatures of materials due to both solar heat gain and nighttime-sky heat loss.

1. Temperature Change (Range): 120 deg F, ambient; 180 deg F, material surfaces.

1.3 SUBMITTALS

A. Product Data: Include styles, material descriptions, construction details, fabrication details, dimensions of individual components and profiles, mounting accessories, features, and finishes for canopies.

- B. Shop Drawings: Show location and extent of canopies. Include elevations, sections, and details not shown in Product Data. Show materials, fabrication, dimensions, mounting heights, connections, anchorages, installation details, attachments to other work, operational clearances, and relationship to adjoining work.
 - 1. Show locations for blocking, reinforcement, and supplementary structural support to be provided by others.
 - 2. For installed products indicated to comply with design loads, include structural analysis data signed and sealed by the qualified professional engineer responsible for their preparation. Calculate requirements for supporting canopies. Verify capacity of members and connections to support loads and verify loads, point reactions, and locations for attachment of canopies to structure with those indicated on Drawings.
- C. Samples for Initial Selection: For each colored or finished component of each type of canopy indicated.
- D. Welding certificates.
- E. Qualification Data: For Installer, fabricator and professional engineer.
- F. Research/Evaluation Reports: For anchors and fasteners.
- G. Maintenance Data: For canopies to include in maintenance manuals.
- H. Warranty: Special warranty specified in this Section.

1.4 QUALITY ASSURANCE

- A. Fabricator Qualifications: Shop that employs skilled workers who custom-fabricate products similar to those required for this Project and whose products have a record of successful in-service performance.
 - 1. Fabricator's responsibilities include fabricating and installing canopies and providing professional engineering services needed to assume engineering responsibility.
- B. Source Limitations: Obtain canopies through one source from a single manufacturer.
- C. Welding: Qualify procedures and personnel according to the following:
 - 1. AWS D1.1/D1.1M, "Structural Welding Code--Steel."
 - 2. AWS D1.2, "Structural Welding Code--Aluminum."
- D. Regulatory Requirements: Provide canopies complying with or exceeding requirements of Building Code of New York State.

1.5 PROJECT CONDITIONS

- A. Weather Limitations: Proceed with installation only when existing and forecasted weather conditions permit installation of canopies in exterior locations to be performed according to manufacturers' written instructions and warranty requirements.
- B. Field Measurements: Where canopy installation is indicated to fit to other work, verify dimensions of other work by field measurements before fabrication and indicate measurements on Shop Drawings. Allow clearances for fenestration operation throughout the entire operating range. Notify Architect of discrepancies. Coordinate fabrication schedule with construction progress to avoid delaying the Work.

1.6 WARRANTY

- A. Special Warranty: Manufacturer's standard form in which manufacturer and fabricator agree to repair or replace components of canopies that fail in materials or workmanship within specified warranty period.
 - 1. 20 years warranty.

PART 2 - PRODUCTS

2.1 SOLID METAL CANOPY

- A. Solid Metal Canopy: Fabricate from aluminum decking and frame, and as follows:
 - 1. Framing and fascia shall be extruded aluminum, alloy 6063-T6, in profile and thickness as indicated on drawings and as required for design loading conditions.
 - 2. Decking shall be 0.078" thick square corrugated aluminum decking 2-3/4" deep
 - 3. Supports shall be hanger rods type.
 - 4. Fascia shall be .125" thick, in 12" smooth face style.
 - 5. Finish shall be 2-coat Kynar in color selected by Architect from all available choices.
 - 6. Basis-of-Design Product: Mapes Super Lumideck by Mapes Industries, Inc., or equal.
- B. Canopy shall be fabricated in the shop and shipped in a knocked-down condition for field assembly.

PART 3 - EXECUTION

3.1 EXAMINATION

- A. Examine substrates, areas, and conditions, with Installer present, for compliance with requirements for supporting members, blocking, inserts, installation tolerances, and other conditions affecting performance.
 - 1. Proceed with installation only after unsatisfactory conditions have been corrected.

3.2 INSTALLATION, GENERAL

- A. General: Install canopies at locations and in position indicated, securely connected to supports, free of rack, and in proper relation to adjacent construction. Use mounting methods of types described and in compliance with Shop Drawings and fabricator's written instructions.
- B. Site Assembly:
 - 1. All connections shall be mechanically assembled utilizing 3/16 fasteners with a minimum shear stress of 350 lb. Pre-welded or factory-welded connections are not acceptable.
 - 2. Decking shall be designed with interlocking extruded aluminum members with mechanical fasteners field applied to provide structural integrity.
 - 3. Concealed drainage. Water shall drain from covered surfaces into intermediate trough and be directed to downspout from rear gutter
- C. Install canopies after other finishing operations, including joint sealing and painting, have been completed.
- D. Anchoring to In-Place Construction: Use anchors, fasteners, fittings, hardware, and installation accessories where necessary for securing canopies to structural support and for properly transferring load to in-place construction.
- E. Corrosion Protection: Coat concealed surfaces of aluminum that will come into contact with grout, concrete, masonry, wood, or dissimilar metals with a heavy coat of bituminous paint.
- F. Coordinate canopy installation with flashing and joint-sealant installation so these materials are installed in sequence and manner that prevent exterior moisture from passing through completed exterior wall and roof assemblies.

3.3 CLEANING AND PROTECTION

- A. Clean canopy surfaces after installation, according to manufacturer's written instructions.
- B. Touchup Painting: Immediately after erection, clean field welds, connections, and abraded areas. Paint uncoated and abraded areas with same or compatible material as used for shop-applied finish painting.
 - 1. Apply by brush or spray to provide a minimum 2.0-mil (0.05-mm) dry film thickness.
- C. Provide final protection and maintain conditions, in a manner acceptable to manufacturer and Installer, that ensure that canopies are without damage or deterioration at time of Substantial Completion.
- D. Replace damaged canopies that cannot be repaired, in a manner approved by Architect, before time of Substantial Completion.

13 January 2022
Conformed Specifications
SED #66-23-00-01-0-346-001

Yonkers Joint Schools Construction Board
Community School 35

END OF SECTION 105316

SECTION 110633 - STAGE CURTAINS AND RIGGING

PART 1 - GENERAL.

1.1 SUMMARY

- A. This Section includes the following types of stage curtain rigging and stage curtains:
 - 1. Front-setting curtains including front curtain and valance.
 - 2. Traveler curtains (legs).
 - 3. Dead-hung battens for curtains.
 - 4. Stage tracks for curtains.

1.2 DEFINITIONS

- A. Batten: Steel pipe supporting curtain by means of cables or chains from overhead structural support.
- B. Overlap: Track that extends beyond curtain centerline to ensure closure of biparting curtain.
- C. Rigging: General term for hardware used to move scenery, lights, or curtains on or over the stage.
- D. Scrim: Loosely woven fabric curtain that appears opaque when lit from the front and transparent when backlit.
- E. Trim: Adjustment of height or level of curtain or equipment.

1.3 PERFORMANCE REQUIREMENTS

- A. Structural Performance: Provide rigging capable of withstanding the effects of the following design loads and the weight of stage curtains.
 - 1. Design Loads: As indicated.

1.4 SUBMITTALS

- A. Product Data: For each type of product indicated.
- B. Shop Drawings: Show fabrication and installation details for stage curtains. Include plans, elevations, sections, details, attachments to other work, and the following:
 - 1. Operating clearances.
 - 2. Requirements for supporting curtains, track, and equipment. Verify capacity of each track and rigging component to support loads.

3. Locations of equipment components, switches, and controls. Differentiate between manufacturer-installed and field-installed wiring.
 4. Include structural analysis data for rigging signed and sealed by the qualified professional engineer responsible for their preparation.
- C. Samples for Initial Selection: For each type of stage curtain indicated; include color charts showing the full range of colors, textures, and patterns available, together with a 12-inch-(300-mm-) square sample (any color) of each type fabric.
- D. Samples for Verification: For each type of fabric from dye lot to be used for the Work, with specified treatments applied, and showing complete pattern and texture repeat, if any. Mark top and face of fabric. Prepare Samples of size indicated below.
1. Size: Not less than 36 inches (900 mm) square.
- E. Product Certificates: For each type of product, signed by product manufacturer.
1. Fabric: Give name of flame-retardant chemical used, identification of applicator, treatment method, application date, allowable life span for treatment, and details of any restrictions and limitations.
 2. Rigging: Suspended battens and tracks comply with requirements.
- F. Qualification Data: For Installer. Include lists of completed projects with project names and addresses, names and addresses of architects and owners, and other information specified.
- G. Maintenance Data: For stage curtains and rigging to include in maintenance manuals.
- H. Warranties: Special warranties specified in this Section.

1.5 QUALITY ASSURANCE

- A. Installer Qualifications: A firm or individual experienced in installing stage curtains and rigging similar in material, design, and extent to those indicated for this Project, whose work has resulted in applications with a record of successful in-service performance.
- B. Fire-Test-Response Characteristics: Provide stage curtains with the fire-test-response characteristics indicated, as determined by testing identical products per test method indicated below by UL or a testing and inspecting agency acceptable to authorities having jurisdiction.
1. Flame-Resistance Ratings: NFPA 701.
 2. Permanently attach label to each fabric of curtain assembly indicating whether fabric is inherently and permanently flame resistant or treated with flame-retardant chemicals, and whether it will require retreatment after designated time period or cleaning.

- C. Preinstallation Conference: Conduct conference at Project site to comply with requirements in Division 1 Section "Project Management and Coordination."

1.6 PROJECT CONDITIONS

- A. Field Measurements: Verify stage-curtain openings and the dimensions of other construction by field measurements before fabrication and indicate measurements on Shop Drawings.

1.7 WARRANTY

- A. Special Warranty for Rigging Equipment: Manufacturer's standard form in which manufacturer agrees to repair or replace components of rigging equipment that fail in materials or workmanship within specified warranty period.

- 1. Failures include, but are not limited to faulty operation of rigging equipment.

- B. Warranty Period: Two years from date of Substantial Completion.

PART 2 - PRODUCTS

2.1 CURTAIN FABRICS

- A. General: Provide fabrics inherently and permanently flame resistant to comply with requirements indicated. Provide fabrics from the same dye lot.

- B. Polyester Velour: Napped fabric of 100 percent Avora polyester weighing not less than 22 oz./linear yard, with product weight 1.4 lbs/linear yard; inherently and permanently flame resistant; 64-inch (1372-mm) minimum width.

- 1. Basis of Design Product: 22 oz. Encore™ Synthetic Velour, IFR by Rose Brand or equal product by one of the following:
 - a. J. L. de Ball America, Inc.
 - b. KM Fabrics, Inc.

- 2. Colors, Textures, and Patterns: Bermuda.

- C. Lining: Yarn-dyed denim cloth of 100 percent cotton; woven in a warp-faced twill; 54-inch (1372-mm) minimum width.

- D. Commando: 100 percent cotton short-napped fabric weighing not less than 16 oz./linear yard (495 g/linear meter) before flame-retardant treatment; twill weave with soft uniform texture; 54-inch (1372-mm) minimum width.

- 1. Products: Subject to compliance with requirements, provide one of the following:
 - a. Dazian; Duvetyne Heavy Weight.
 - b. Fred Krieger & Co., Inc.; Heavy Commando.

- c. Rose Brand; Black Commando.
- d. Valley Forge Fabrics, Inc.; Commando.

2.2 CURTAIN FABRICATION

- A. General: Affix permanent label, stating compliance with requirements of authorities having jurisdiction, in accessible location on curtain not visible to audience. Provide vertical seams, unless otherwise indicated. Arrange vertical seams so they do not fall on faces of pleats. Do not use fabric cuts less than one-half width.
 - 1. Vertical Hems: Provide vertical hems not less than 2 inches (50 mm) wide, and not less than 4 inches (102 mm) wide at borders, valance, and tormentors, with not less than a 1-inch (25-mm) tuck, and machine-sewn with no selvage material visible from front of curtain. Sew open ends of hems closed.
 - 2. Leading Edge Turnbacks: Provide turnbacks formed by folding not less than 12 inches (300 mm) of face fabric back, with not less than a 1-inch (25-mm) tuck, and secured by sewing turnbacks vertically.
 - 3. Top Hems: Reinforce top hems by double-stitching 3-1/2-inch- (89-mm-) wide, heavy jute webbing to top edge with not less than 2 inches (50 mm) of face fabric turned under.
 - 4. Pleats: Provide 75 percent fullness in curtains, exclusive of turnbacks and hems, by sewing additional material into 3-inch (75-mm) double-stitched box pleats spaced at 12 inches (300 mm) o.c. along top hem reinforcement.
 - 5. Grommets: Brass, No. 3, centered on each box pleat and 1 inch (25 mm) from corner of curtain, for snaps or S-hooks.
 - a. For black curtains, provide brass or aluminum grommets with black finish.
 - 6. Bottom Hems:
 - a. For curtains that do not hang to the floor, provide hems not less than 3 inches (75 mm) deep with 3/4-inch (19-mm) weight tape.
 - b. For floor-length curtains, provide hems not less than 6 inches (150 mm) deep with separate, interior, 100 percent cotton, heavy canvas chain pocket equipped with proof coil chain. Stitch chain pockets so chain will ride 2 inches (50 mm) above finished bottom edge of curtain.
 - 1) Proof Coil Chain: Grade 30, No. 8, zinc plated, 3/16 inch (4.7 mm), ASTM A 413/A 413M.
 - 7. Velour Curtains: Fabricate with the fabric nap down.
 - 8. Lining: Provide lining for each curtain in same fullness as face fabric, and finished 2 inches (50 mm) shorter than face fabric. Attach lining to face fabric along bottom and side seams with 4-inch- (100-mm-) long strips of heavy woven cotton tape.
- B. Tie Lines: Braided soft cotton, black or white to best match curtain; not less than 5/8 inch (16 mm) wide by 36 inches (900 mm) long.
- C. Fabricate curtains from the following material and requirements:

1. Front Stage Curtain and Valence: Velour with lining. Valence shall be board mounted.
2. Travelers (Legs): Commando Cloth (no liner).

2.3 RIGGING

- A. Curtain Battens: Fabricate battens from steel pipe with a minimum number of joints. As necessary for required lengths, connect pipe with a drive-fit pipe sleeve not less than 18 inches (450 mm) long, and secure with four flush rivets, plug welds, threaded couplings, or another equally secure method. Shop-paint completed pipe battens with black paint and with 1-inch- (25-mm-) wide yellow stripe at the center of each batten.
1. Steel Pipe: ASTM A 53/ A 53M, Grade A, standard weight (Schedule 40), black, 1-1/2-inch (40-mm) nominal diameter, unless otherwise indicated.
- B. S-Hooks: Track manufacturer's heavy-duty plated-wire hooks.
- C. Snap Hooks: Track manufacturer's heavy-duty hooks.
- D. Supports, Clamps, and Anchors: Sheet steel in manufacturer's standard thicknesses, galvanized after fabrication according to ASTM A 153/A 153M, Class B.
- E. Trim and Support Cable: 1/4-inch- (6-mm-) diameter, 7x19 galvanized steel aircraft cable with a breaking strength of 7000 lb (3175 kg). Provide fittings complying with cable manufacturer's written recommendations for size, number, and method of installation, including a drop-forged galvanized turnbuckle to allow for leveling.
- F. Trim and Support Chain: Grade 80 hardened alloy steel chain rated for overhead lifting, ASTM A 391/A 391M.
- G. Inserts, Bolts, Rivets, and Fasteners: Manufacturer's standard corrosion-resistant units.
- H. Steel Track: Fabricate of roll-formed, galvanized, commercial-quality, zinc-coated steel sheet; complying with ASTM A 653/A 653M, G60 (Z180) coating designation, with continuous bottom slot, and with each half of track in one continuous piece.
1. Available Products: Subject to compliance with requirements, products that may be incorporated into the Work include, but are not limited to, the following:
 - a. Automatic Devices Company; Besteel 100 series.
 - b. H & H Specialties Inc.; 200 series
 2. Minimum Base-Metal Thickness: Not less than 0.0528 inch (1.35 mm)

2.4 STEEL-CURTAIN-TRACK FABRICATION

- A. Medium-Duty Track System: Equip track with adjustable, single- and double-end pulley and floor blocks containing guarded ball-bearing wheels. Provide single curtain carriers of plated steel with a pair of nylon wheels riveted parallel to body. Provide one master

carrier, for each leading curtain edge, of plated steel with two pairs of nylon wheels and with two line clamps per carrier. Equip carriers with plated-steel swivel eye for attaching curtain snap or S-hook. Provide end stops for track and an adjustable floor block designed for maintaining proper tension on 1/4-inch (6-mm) stretch-resistant operating cord consisting of braided synthetic-fiber jacket over solid, synthetic-fiber, linear, center filaments.

1. Operating Line: Manufacturer's standard 3/8-inch (9-mm) stretch-resistant operating cord consisting of braided synthetic-fiber jacket over solid, synthetic-fiber, linear, center filaments.
2. Track Lap Clamp: Metal to match track channel for attaching double-sectioned track at center overlap.
3. Curtain Carriers: For track spaced at 12 inches (300 mm) o.c.
4. Fold Guide: Equip carriers with rear-fold or backpack guide and rubber spacers to permit offstage curtain folding, sized for use with operating line if any.
5. Basis of Design Product: Automatic Devices Company "Besteel Model 171-N" or equal by H&H Specialties Inc.

PART 3 - EXECUTION

3.1 EXAMINATION

- A. Examine areas and conditions, with Installer present, for compliance with requirements for supporting members, blocking, installation tolerances, clearances, and other conditions affecting performance of stage-curtain work. Proceed with installation only after unsatisfactory conditions have been corrected.
- B. Examine inserts, clips, blocking, or other supports required to be installed by others to support tracks and battens. Proceed with installation only after unsatisfactory conditions have been corrected.

3.2 INSTALLATION, GENERAL

- A. Install stage-curtain system according to track manufacturer's and curtain fabricator's written instructions.

3.3 BATTEN INSTALLATION

- A. Install battens by suspending at heights indicated with trim and support cable spaced to support load, but do not exceed 10 feet (3 m) o.c.
 1. Cable: Secure cables either directly to structures or to inserts, eye screws, or other devices that are secure and appropriate to substrate and that will not deteriorate or fail with age or elevated temperatures. Attach other cable end to pipe clamps with turnbuckles, moused or fixed with nuts after adjustment, to prevent loosening.
 2. Chain: Secure chain with load-rated terminations.

3.4 TRACK INSTALLATION

- A. Batten-Hung Tracks: Install track by suspending from pipe batten with manufacturer's track clamp hangers attached to batten pipe clamps at spacing, according to manufacturer's written instructions.
- B. Spacing: Do not exceed the following dimensions between supports:
 - 1. Medium-Duty Track: 48 inches (1219 mm).
- C. Install track for center-parting curtains with not less than 24-inch (600-mm) overlap of track sections at center, supported by special lap clamps.

3.5 CURTAIN INSTALLATION

- A. Track Hung: Secure curtains to track carriers with track manufacturer's special heavy-duty S-hooks or snap hooks.
- B. Batten Hung: Secure curtains to pipe battens with trim and support cable tie lines or chains.

3.6 DEMONSTRATION

- A. Engage a factory-authorized service representative to test system and to train Owner's personnel to rig, adjust, operate, and maintain stage curtains, tracks, and draw-curtain machines. Refer to Division 1 Section "Demonstration and Training."

END OF SECTION 110633

SECTION 111319 - STATIONARY LOADING DOCK EQUIPMENT

PART 1 - GENERAL

1.1 SUMMARY

- A. This Section includes the following:
 - 1. Dock lifts (scissors lifts).
- B. Related Sections include the following:
 - 1. Division 26 Sections for electrical wiring and connections for loading dock equipment

1.2 DEFINITIONS

- A. Operating Range: Maximum amount of travel above and below the loading dock level.
- B. Working Range: Recommended amount of travel above and below the loading dock level for which loading and unloading operations can take place.

1.3 SUBMITTALS

- A. Product Data: Include construction details, material descriptions, rated capacities, operating characteristics, furnished specialties, accessories, dimensions of individual components and profiles, and finishes.
- B. Shop Drawings: Show fabrication and installation details. Include plans, elevations, sections, details, and attachments to other work.
 - 1. For installed products indicated to comply with design loads, include structural analysis data signed and sealed by the qualified professional engineer responsible for their preparation.
 - 2. Wiring Diagrams: Power, signal, and control wiring.
- C. Qualification Data: For Installer and professional engineer.
- D. Product Test Reports: Based on evaluation of tests performed by manufacturer and supervised and verified by a qualified independent professional engineer, indicate compliance of dock levelers with requirements of MH 30.1 for determining rated capacity, which is based on comprehensive testing within the last two years of current products.
 - 1. Submittal Form: According to MH 30.1, Appendix A.
- E. Maintenance Data: For loading dock equipment to include in maintenance manuals.

- F. Warranties: Special warranties specified in this Section.

1.4 QUALITY ASSURANCE

- A. Installer Qualifications: Manufacturer's authorized representative who is trained and approved for installation of units required for this Project.
- B. Source Limitations: Obtain each type of loading dock equipment through one source from a single manufacturer.
- C. Preinstallation Conference: Conduct conference at Project site to comply with requirements in Division 01.

1.5 PROJECT CONDITIONS

- A. Field Measurements: Indicate measurements on Shop Drawings.
 - 1. Established Dimensions: Where field measurements cannot be made without delaying the Work, establish recessed pit dimensions and proceed with fabricating loading dock equipment without field measurements. Coordinate loading dock construction to ensure that actual dimensions correspond to established dimensions.

1.6 COORDINATION

- A. Coordinate installation of anchorages for loading dock equipment. Furnish setting drawings, templates, and directions for installing anchorages, including sleeves, concrete inserts, anchor bolts, and items with integral anchors, that are to be embedded in concrete or masonry. Deliver such items to Project site in time for installation.
- B. Recessed Loading Dock Equipment: Coordinate size and location of pits to ensure proper clearances and operation of equipment.
 - 1. Concrete, reinforcement, and formwork requirements are specified in Division 03 Section "Cast-in-Place Concrete."
- C. Electrical Requirements: Coordinate wiring requirements and current characteristics of loading dock equipment with building electrical system. See Division 26 Sections.

1.7 WARRANTY

- A. Special Warranty for Lifts: Manufacturer's standard form in which manufacturer agrees to repair or replace dock-leveler components that fail in materials or workmanship within specified warranty period.
 - 1. Failures include, but are not limited to, the following:
 - a. Structural failures including cracked or broken structural support members and load-bearing welds.

- b. Deck plate failures including cracked plate or permanent deformation in excess of 1/4 inch (6 mm) between deck supports.
 - c. Hydraulic system failures including failure of hydraulic seals and cylinders.
 - d. Faulty operation of operators, control system, or hardware.
2. Warranty Period for Structural Assembly: 10 years from date of Substantial Completion.
 3. Warranty Period for Hydraulic System: Two years from date of Substantial Completion.
 4. Warranty Period for Electrical System: Two years from date of Substantial Completion.
 5. Warranty Period for Mechanical Components: Two years from date of Substantial Completion.
 6. Warranty Period for Labor: Two years from date of Substantial Completion.
 7. Warranty shall be for unlimited usage of the leveler for the specified rated capacity over the term of the warranty.

PART 2 - PRODUCTS

2.1 MATERIALS

- A. Steel Plates, Shapes, and Bars: ASTM 36/A 36M.
- B. Rolled-Steel Floor Plate: ASTM A 786/A 786M, rolled from steel plate complying with ASTM A 572/A 572M, Grade 55 (380).
- C. Steel Tubing: ASTM A 500, cold formed.
- D. Welding Rods and Bare Electrodes: Select according to AWS specifications for metal alloy welded.

2.2 DOCK LIFTS (SCISSORS LIFTS)

- A. General: Scissors-type hydraulic dock lift of capacity, size, and construction indicated; complete with controls, safety devices, and accessories required.
 1. Platform Size: 6' x 10'
 2. Lift Capacity: 8,000 lbs
 3. Axle Capacity, Ends: 6,500 lbs
 4. Axle Capacity, Sides: 5,000 lbs
 5. Lowered Height: 12"
 6. Travel: 58"
 7. Speed: 10 fpm
 8. Power Unit: 5 HP
 9. Basis of Design Product: Model 3220 Recessed Dock Lift manufactured by Advance Lifts, Inc. or equal by one of the following:
 - a. Autoquip Inc.
 - b. Southworth Inc

- B. Quality Standard: MH 29.1, "Safety Requirements for Industrial Scissors Lifts."
- C. Hydraulic Operating System: Self-contained, electric, hydraulic power unit for raising and lowering lift; of size, type, and operation needed for capacity of lift indicated; controlled from a remotely located push-button station.
 - 1. Power Unit: Consisting of continuous-duty motor, high-pressure gear pump, valve manifold, oil-line filters, and oil reservoir.
 - a. Hydraulic Pit Lift: Provide 5 HP, 230VAC, 60 Hz, 3 phase rating; pre-wired power unit.
 - b. Equip manifold with relief valve, check valve, pressure-compensated flow-control valve, and solenoid valve and with provisions for lowering lift manually if power fails.
 - c. Equip reservoir, valve manifold, and pressure line with oil-line filters.
 - 2. Cylinders: Equip lift with no less than two heavy duty machine grade cylinders with mechanical internal stops and return lines from breather vents to the reservoir. Cylinder rods shall be chrome plated and polished. The cylinders shall be equipped with flow controls to prevent free fall in compliance with MH29.1.
 - 3. Remote-Control Station: Multibutton control station of the constant-pressure type with UP and DOWN push buttons. Controller shall consist of magnetic motor starter with 3-pole adjustable overloads and 24-V control transformer with 4-A, fused secondary prewired to terminal strips and enclosed in NEMA ICS 6, Type 12 box.
 - a. Upper-Travel-Limit Switch: Equip unit with manufacturer's standard, adjustable, upper-travel-limit switch.
 - b. Hydraulic Pit Lift: Provide optional quick disconnect push button control.
 - 4. Hydraulic Oil: Provide biodegradable hydraulic oil for lift.
- D. Construction: Fabricate lift from structural-steel shapes rigidly welded and reinforced for maximum strength, safety, and stability. Design assembly to withstand deformation during both operating and stored phases of service. Provide mounting brackets and removable lifting eyes for ease of installation.
 - 1. Platform: Fabricate platform from heavy steel plate with beveled toe guards on all four sides to comply with requirements of MH 29.1.
 - 2. Hinged Bridge: Hinged, throw-over bridge bolted to full-length, heavy-duty, piano-type hinge welded to toe guard at end of platform. Provide bridge complete with heavy-duty lifting chains. Chamfer edge of bridge to minimize obstructing wheels of material-handling vehicles.
 - 3. Scissors Mechanism: Fabricate leg members from heavy, steel-formed tube members to provide maximum strength and rigidity.
 - 4. Bearings: Equip lift with lifetime lubricated bearings for minimum maintenance.

5. Handrails: Equip lift with removable handrails on two sides of platform. Handrails shall be 42 inches high with midrail and 4-inch- (102-mm-) high kick plate at bottom. Mount rail sockets flush with platform surface.
6. Maintenance Leg: Removable, safety maintenance leg or hinged, safety maintenance bars.
7. Toe Protection: Along entire unprotected side of lifts; painted yellow with black stripes to comply with ANSI Z535.1.
8. Bi-Parting Gates: Provide bi-parting gate accessory for both of the 6' sides (52" clear width).

2.3 FINISHES, GENERAL

- A. Comply with NAAMM's "Metal Finishes Manual for Architectural and Metal Products" for recommendations for applying and designating finishes.
- B. Finish loading dock equipment after assembly and testing.
- C. Galvanizing: Hot-dip galvanize items as indicated to comply with applicable standard listed below:
 1. ASTM A 123/A 123M for iron and steel loading dock equipment.
 2. ASTM A 153/A 153M for iron and steel hardware for loading dock equipment.
- D. Painted Surfaces: Provide manufacturer's standard paint system in color selected by Architect.

PART 3 - EXECUTION

3.1 EXAMINATION

- A. Examine areas and conditions, with Installer present, for compliance with requirements for installation tolerances and other conditions affecting performance of loading dock equipment.
- B. Examine roughing-in for electrical systems for loading dock equipment to verify actual locations of connections before equipment installation.
- C. Examine walls and floors of pits for suitable conditions where recessed loading dock equipment is to be installed. Pits shall be plumb and square and properly sloped for drainage from back to front of loading dock.
- D. Proceed with installation only after unsatisfactory conditions have been corrected.

3.2 PREPARATION

- A. Coordinate size and location of loading dock equipment indicated to be attached to or recessed into concrete or masonry, and furnish anchoring devices with templates, diagrams, and instructions for their installation.

- B. Set curb angles in concrete edges of dock-leveler recessed pits with tops flush with loading platform. Fit exposed connections together to form hairline joints.
- C. Clean recessed pits of debris.

3.3 INSTALLATION

- A. General: Install loading dock equipment, including motors, pumps, control stations, wiring, safety devices, and accessories as required for a complete installation.
 - 1. Rough-in electrical connections according to requirements specified in Division 26.

3.4 ADJUSTING AND CLEANING

- A. Adjust loading dock equipment for proper, safe, efficient operation.
- B. Test lifts for vertical travel within operating range indicated.
 - 1. Perform a full load test ascertaining the lift makes smooth, level and accurate starts and stops.
 - 2. Perform final tests in presence of the Owner's representative.
- C. Provide operation and maintenance training for Owner's representative.
- D. Restore marred, abraded surfaces to their original condition.

END OF SECTION 111319

The following additions, substitutions, or clarifications are extracted from the (5) Bid Addenda issued with this project during bidding. This insert is intended to summarize addendum information relevant to this specification section. See Bid Addenda issued by the City of Yonkers for complete contract document changes.

Bid Addendum No. 4:

Provide a quantity of 2 refrigerators and 2 microwaves in room faculty 107. Provide a locking stainless, ADA undercounter refrigerator at Exam room 106N similar or equal to Uline ADA U-ADA24RS-13B

SECTION 113100 - RESIDENTIAL APPLIANCES

PART 1 - GENERAL

1.1 SUMMARY

A. This Section includes the following:

1. Refrigerator
2. Microwave
3. Icemaker

1.2 SUBMITTALS

- A. Product Data: For each type of product indicated. Include operating characteristics, dimensions of individual appliances, and finishes for each appliance.
- B. Appliance Schedule: For appliances; use same designations indicated on Drawings.
- C. Manufacturer Certificates: Signed by manufacturers certifying that products comply with requirements.
- D. Product Test Reports: Based on evaluation of comprehensive tests performed by manufacturer and witnessed by a qualified testing agency, for each product.
- E. Research/Evaluation Reports: For each product.
- F. Maintenance Data: For each product to include in maintenance manuals.
- G. Warranties: Special warranties specified in this Section.

1.3 QUALITY ASSURANCE

- A. Installer Qualifications: An employer of workers trained and approved by manufacturer for installation and maintenance of units required for this Project.
- B. Source Limitations: Obtain residential appliances through one source.
1. Provide products from same manufacturer for each type of appliance required.
- C. Product Options: Information on Drawings and in Specifications establishes requirements for product's aesthetic effects and performance characteristics. Aesthetic effects are indicated by dimensions, arrangements, alignment, and profiles of components and assemblies as they relate to sightlines, to one another, and to adjoining construction. Performance characteristics are indicated by criteria subject to verification by one or more methods including preconstruction testing, field testing, and in-service performance.

- D. Regulatory Requirements: Comply with provisions of the following product certifications:
1. NFPA: Provide electrical appliances listed and labeled as defined in NFPA 70, Article 100, by a testing agency acceptable to authorities having jurisdiction, and marked for intended use.
 2. UL and NEMA: Provide electrical components required as part of residential appliances that are listed and labeled by UL and that comply with applicable NEMA standards.
 3. ANSI: Provide gas-burning appliances that comply with ANSI Z21 Series standards.
 4. NAECA: Provide residential appliances that comply with NAECA standards
- E. Regulatory Requirements, Accessibility: Where residential appliances are indicated to comply with accessibility requirements, comply with ANSI A117.1 - 2017 regulations.
1. Operable Parts: Provide controls with forward reach no higher than 48 inches (1219 mm) above the floor, horizontal front reach no more than 25 inches (635 mm), horizontal side reach no more than 24 inches (610 mm), and that do not require tight grasping, pinching, or twisting of the wrist and that operate with a force of not more than 5 lbf (22.2 N).
 2. Refrigerator/Freezer: Provide 50 percent of freezer space within 54 inches (1370 mm) of the floor.
- F. Energy Ratings: Provide residential appliances that carry labels indicating energy-cost analysis (estimated annual operating costs) and efficiency information as required by the FTC Appliance Labeling Rule.
1. Provide appliances that qualify for the EPA/DOE ENERGY STAR product labeling program.
- G. Preinstallation Conference: Conduct conference at Project site to comply with requirements in Division 01.

1.4 WARRANTY

- A. Special Warranties: Manufacturer's standard form in which manufacturer of each appliance specified agrees to repair or replace residential appliances or components that fail in materials or workmanship within specified warranty period.
1. Refrigerator: One year parts and labor.
 2. Microwave: One year parts and labor; five years magnetron tube.
 3. Icemaker: 3 years parts and labor / 5 years compressor parts.

PART 2 - PRODUCTS

2.1 APPLIANCES

- A. Microwave: 2.2 cu. ft. countertop microwave oven 1200 watts.

1. Color: Stainless steel
2. Power Levels: 10
3. Control Type: Electronic touch
4. Display: Electronic digital display with clock.
5. Turntable: Glass
6. Turntable Size: 16 inches
7. Control Features: Sensor cooking controls, inverter defrost technology
8. Unit Dimensions: 13-3/4" h x 19-1/2" d x 24"w
9. Basis of Design Product: GE #JES2251SJ or equal.

B. Refrigerators: Energy Star 21.1 cu. ft. capacity, top-freezer refrigerator.

1. Color: White.
2. Configuration: Freestanding, top-freezer refrigerator with textured rounded doors.
3. Defrost Type: Frost free.
4. Temperature Management: Air tower in freezer
5. Control Type: Upfront temperature controls.
6. Dispenser: No dispenser
7. Icemaker: Factory installed icemaker
8. Refrigerator Shelves and Freezer Floor: Spill proof.
9. Freezer Shelves: One
10. Freezer Door Bins: Two.
11. Refrigerator Shelves: Two
12. Refrigerator Drawers: Three
13. Case Dimensions: 66.75"h x 34"d x 32.875"w
14. Basis of Design Product: GE #GIE21GTHWW, or equal.

C. Undercounter Micro Chewblet Icemaker: Compact footprint and front-ventilated design to fit undercounter with no side, top or back clearances required. Rear utility access shall allow for rear electrical and plumbing connection with no rear clearance required. Legs shall be removable. Bin and shroud shall be removable for service and maintenance. Units shall have the following features:

1. Stainless steel evaporator, auger and top bearing.
2. Oversized, heavy duty, tapered roller bearing.
3. Energy efficient, uses 25% less energy and 40% less water than comparable machines.
4. Air cooled condenser
5. Low water safety circuit
6. Automatic flushing and semi-automatic cleaning cycle.
7. Ice Type: Chewblet
8. Dimensions: 23-1/2"w x 26"d x 39"h (with legs) or 33" h (without legs)
9. Electrical: 115V / 60 Hz/ 1 phase, 8 amps
10. NSF listed
11. Basis of Design Unit: UMD425A80 Maestro Plus Series by Follett, or equal.

2.2 FINISHES, GENERAL

- A. Comply with NAAMM's "Metal Finishes Manual for Architectural and Metal Products" for recommendations for applying and designating finishes.
- B. Protect mechanical finishes on exposed surfaces from damage by applying a strippable, temporary protective covering before shipping.
- C. Color-Coated and Stainless-Steel Finish: Provide appliances with manufacturer's standard finish complying with manufacturer's written instructions for surface preparation including pretreatment, application, baking, color, gloss, and minimum dry film thickness for painted finishes or ground and polished stainless-steel surfaces for uniform, directionally textured finish.

PART 3 - EXECUTION

3.1 EXAMINATION

- A. Examine conditions, with Installer present, for compliance with requirements for installation tolerances and other conditions affecting performance of work.
- B. Examine roughing-in for piping systems to verify actual locations of piping connections before equipment installation.
- C. Proceed with installation only after unsatisfactory conditions have been corrected.

3.2 INSTALLATION, GENERAL

- A. General: Comply with manufacturer's written instructions.
- B. Built-in Equipment: Securely anchor units to supporting cabinets or countertops with concealed fasteners. Verify that clearances are adequate for proper functioning and rough openings are completely concealed.
- C. Freestanding Equipment: Place units in final locations after finishes have been completed in each area. Verify that clearances are adequate to properly operate equipment.
- D. Utilities: Refer to Divisions 22 and 26 for plumbing and electrical requirements.

3.3 CLEANING AND PROTECTION

- A. Test each item of residential appliances to verify proper operation. Make necessary adjustments.
- B. Verify that accessories required have been furnished and installed.
- C. Remove packing material from residential appliances and leave units in clean condition, ready for operation.

13 January 2022
Conformed Specifications
SED #66-23-00-01-0-346-001

Yonkers Joint Schools Construction Board
Community School 35

END OF SECTION 113100

**DIVISION 11
SECTION 11 40 00**

TABLE OF CONTENTS

SPECIFIC CONDITIONS	PAGE NUMBERS
PART 1- GENERAL	114000-01
PART 2- PRODUCTS	114000-15
PART 3- EXECUTION	114000-48
PART 4- EQUIPMENT	114000-53
BID QUOTATION SUMMARY FORM	114000-54
EQUIPMENT SPECIFICATIONS	114000-55 through 114000-72
FABRICATION DETAILS	114000-73 through 114000-92
APPENDIX:	
A. Brochure Lead Sheet Submittal	114000-93
B. Alternate/Substitution Request Form	114000-94 & 114000-95
C. Sample Itemized Bid Proposal Form	114000-96
D. Mandatory Alternate Proposal Form	114000-97
E. Alternate Proposal Form	114000-98

SECTION 114000 - FOODSERVICE EQUIPMENT

PART 1 – GENERAL

This document was prepared to inform of the specific information and requirements. If there is anything in this document that is in conflict with the documents provided by the Architect the architects documents shall prevail. Please review these requirements carefully.

1.1 PREPARATION & PRESENTATION OF BIDS

All bids submitted are to include item number, quantity, Item name, status, unit price and total for each item, with a separate sub-total price for buy-out and fabricated equipment combined, delivery, installation and performance bond. Any and all City, State, occupational and government taxes which are applicable to this installation shall be included and added as a separate charge to this bid. All figures shall be included in a grand total contract price.

1.2 RELATED DOCUMENTS

A. General provisions of the contract, including General Conditions, Supplementary Conditions and General Documents, other Division I specification Documents and other Division I specification sections apply under this section.

1.3 SCOPE OF WORK

- A. Furnish all labor, materials and services necessary for the provision (furnish and install) of food service equipment to achieve the highest level of quality throughout and in strict accordance with the Contract Documents and local codes including that which is reasonably inferred. No extra charge will be allowed for that which the Food Service Equipment Contractor should have been familiar.
- B. Supervise and provide required instructions for work to be performed by other contractors in connection with requirements for all equipment under this section in order to achieve complete and operable equipment and systems to satisfy equipment manufacturer's recommendations.
- C. Check completed rough-ins for conformance to dimension rough-in plans. On projects with new construction or extensive renovation this check needs to occur before slabs are poured and walls are closed in. Submit field report to Owner identifying material variances.
- D. Be responsible for the disassembly (if required), removal, storage and protection (at contractor's expense), handling and setting in place all of those items designed in the contract documents as existing/relocate, existing/modify, and existing/relocate/modify at the appropriate time.
- E. Within the scope of this work the Foodservice Equipment Contractor needs to provide and install any and all options and/or accessories incidental to the installation of the equipment to allow it to perform its desired function and conform to the manufacturer's recommendations for the installation.

1.4 RELATED WORK SPECIFIED ELSEWHERE

- A. Floors and setting beds, quarry tile and base, masonry pads, walls and finishes, ceilings and related building work: Divisions 3 through 9.
 - 1. Quarry tile floor finish to be etched, if required, prior to setting food service equipment in place.
- B. Wall backing to support all wall mounted equipment: Division 5 and/or 9.
- C. All water, waste, indirect waste piping from sinks and ventilators, steam and gas services to the equipment including all shut-off valves, plumbing trim, traps, etc., and final connections to the equipment except as specified herein: Division 22 – Plumbing.
- D. All floor sinks and floor drains: Division 22 - Plumbing.
- E. Piping sleeves for refrigeration and drain lines through building floors: Division 22 - Plumbing.
- F. All electric services and components including wiring to and final connections to all equipment except as specified herein: Division 26 - Electrical.
- G. Grounding type receptacles for all wall mounted outlets to be used for plug-in equipment: Division 26 - Electrical.
- H. Make penetrations in building walls as required to accommodate installation of food service equipment including, among other items, routing of remote refrigeration lines: Division 4, 5 and/or 9.
- I. Removal of existing food service equipment not scheduled for reuse: Division 2.
- J. Installation of mechanical gas shut off valve(s) to shut-off gas supply to cooking equipment in the event of a fire: Division 23 - HVAC.
- K. All hood or ventilator duct work upstream from the connection position: Division 23 - HVAC.
- L. Sub-floor, water proofing, floor depressions, and related building work for cold storage rooms: Divisions 2 through 9.
- M. Concrete setting bed, 6 Mil Visqueen vapor barrier, slab urethane insulation with adequate R value rating, floor and cove base quarry tile with wire mesh and epoxy grout at depressed cold storage rooms: Division 3 through 9.
- N. Furnishing and installation of conduit at cold storage rooms in cooperation with the Food Service Equipment Contractor: Division 26 - Electrical.
- O. Installation of light fixtures furnished loose at cold storage rooms: Division 26 – Electrical.
- P. Connection of cold storage room temperature alarm system to the building security system: Division 26 - Electrical.
- Q. Conduit and connections between cold storage room temperature probes and remote temperature recording devices.
- R. Furnishing and installation of main power lines to refrigeration systems control panel and wiring for control/defrost heaters between panel and coils in accordance with factory supplied wiring diagrams and local codes: Division 26 - Electrical.
- S. Final connection of the recirculating and city water to refrigeration rack: Division 23 - HVAC.
- T. Installation of flexible quick disconnects for water connections to counter-top dispensing units provided “By Owner” and “By Vendor”: Division 22 - Plumbing - Plumbing.
- U. Furnish and install plugs and Neoprene Cords to Countertop Equipment Provided “By owner “ and “By vendor”: Division 26 – Electrical.
- V. Furnish and install Z-bar support framing for ceiling mounted foodservice equipment units including, but not limited to, ventilators, condensate hoods, utensil/pot racks, insulated ceiling panels of cold storage rooms, Note: Foodservice

Equipment contractor will furnish and install hangers from equipment to framing or other support system.

- W. Conduit for beer/beverage lines from beer system power packs/soda systems to dispensing locations: Division 26 – Electrical.
- X. Conduit for refrigeration piping through inaccessible areas, such as under slab on grade: Division 26 – Electrical.
- Y. All field wiring and interconnections required between sub-assemblies for complete and operable systems: Division 26 – Electrical.
- Z. Grease interceptors. Division 22
- AA. Insulated indirect waste lines from ice bins, (non-walk-in) evaporator coils and cold bain maries.

1.5 OWNER/PURVEYOR FURNISHED EQUIPMENT

- A. Utility connections shown on CFL drawings for purveyor furnished equipment are representative of equipment necessary to support the Owner's requirements. Obtain and coordinate manufacturer, model number and utility requirements and represent utility requirements on dimensioned rough-in plans.
- B. Food Service Equipment Contractor to verify requirements and equipment sizes or other characteristics necessary to represent Owner/Operator items completely on the shop drawing submittals even though they may be listed as "NIC/Not in Contract" in the Equipment Specification sections of this document.
- C. Provide flexible disconnects for utility connections (gas, water and steam) to appropriate trades for Owner/Purveyor provided equipment items as specified.

1.6 MODIFICATIONS TO EXISTING EQUIPMENT

- A. Fire Suppression Systems
 - 1. Any modifications necessary to an existing fire suppression system as the result of changes to an exhaust hood or the replacement or rearrangement of equipment to make it comply with local codes are the responsibility of the FSE Contractor.
- B. Confirm that options & accessories specified for modifications to existing equipment units scheduled for reuse are compatible with the manufacturer/model number of the existing units prior to order placement. Notify Consultant accordingly.

1.7 REGULATIONS

- A. All work and materials shall be in accordance with the latest rules and/or regulations of agencies/ authorities having jurisdiction. All regulations, including building codes, and other codes applying to this jurisdiction should be followed. In addition all equipment shall comply with the following:
 - 1. National Electric Manufacturer's Association (N.E.M.A.).
 - 2. Underwriter's Laboratories Inc. (U.L.), must bear label.
 - 3. National Electric code, (N.E.C.).
 - 4. National Sanitation Foundation, (N.S.F.), must bear label.
 - 5. American Society of Mechanical Engineers must carry the (A.S.M.E.) stamp.
 - 6. American Gas Association (A.G.A.).
 - 7. State and Local Health Department Requirements.
- B. The Contract Documents shall govern whenever they require larger sizes or higher standards than are required by regulations.

- C. The regulations shall govern whenever the Contract Documents require something which will violate the regulations.
- D. When seismic regulations are applicable, all equipment shall be fabricated and installed in accordance with those regulations. All seismic requirements shall be shown on all submittals. Submit requested information to the agencies and authorities having jurisdiction.
- E. No extra charge will be paid for furnishing items required by the regulations, but not specified and/or shown on the drawings.
- F. Rulings and interpretations of the enforcing agencies shall be considered a part of the regulations.
- G. The Food Service Equipment Contractor is responsible to maintain the accuracy of equipment drawings and cut books to reflect as built conditions due to equipment deletions, manufacturer and/or model number changes and unanticipated changes to site conditions. It will be the Food Service Equipment Contractor's sole responsibility to notify the Health Department having jurisdiction of all revisions until the project is issued its Certificate of Occupancy.

1.8 ALTERNATES / SUBSTITUTIONS

- A. Alternates/Substitutions must be equal in all respects to the base equipment specified. Alternate/Substitutions must state the manufacturer, model number and include illustration, specifications, capacities and operational data.
- B. All fabricated equipment shall be by one manufacturer acceptable to the Owner and Designer. If the methods specified and detailed are not in accordance with the Food Service Equipment Contractor's methods, he may quote as an alternate /substitutions, using his methods and standards. The alternate /substitutions shall include an itemization of all differences.
- C. If alternates/substitutions require different building conditions, electrical, plumbing, ventilation, etc., from those specified, a complete list of those changes for each item shall be included. If no changes are required, a statement to that effect shall be included. The costs for such changes requested after the bid due date shall be the responsibility of the Food Service Equipment Contractor.
- D. Alternates/substitutions submitted after the bid due date will not be considered. Acceptance or rejection of alternates/substitutions will be at the discretion of the Owner and/or Designer.
- E. The above requirements are waived for alternates requested in the equipment specifications. If an alternate is selected, include the alternate and the requirements for the alternate in all submittals.
- F. When alternates are listed in the item specifications and the primary manufacturer is unable to provide the item(s) specified (i.e. bankruptcy), the F.S.E. Contractor shall provide the equipment from an alternate manufacturer for the same price as originally proposed in the bid quotation.
- G. Alternates/substitution request form is to be completed for each alternate /substitution being requested. See appendix section.

1.9 REVIEW OF CONTRACT DOCUMENTS

- A. Unless expressly stipulated, and in a timely manner, no additional allowances will be made for Contractors or Manufacturers for errors, omissions or ambiguities not reported at time of bidding.
- B. Carefully review and compare the Contract Documents and at once report to Owner and/or Designer any errors, ambiguities, inconsistencies or omissions. Unless expressly stipulated, and in a timely manner, Food Service Equipment Contractor shall be liable to Owner or Designer for any damage resulting from such errors, inconsistencies or omissions in the Contract Documents. Work shall not be done without approved Drawings, Specifications and/or Modifications and without receiving prior written authorization from Owner or Designer.
- C. Where discrepancies are discovered between the drawings and the specifications, regarding quality or quantity, the higher quality or the greater quantity is to be included in the Bid Proposal.
- D. Foodservice Equipment Contractors responsible for verifying and coordinating all items provided in this Section, with the drawings, specifications, manufacturer's requirements, submittals, actual site conditions, adjacent items and associated (Sub-) Contractors; to assure that there are no discrepancies or conflicts. This is to include, but not limited to, quantities, dimensions, clearances required, direction of operation, door swings, utilities, fabrication details and methods, installation requirements, etc.
- E. All accessory items listed in the itemized specifications section are the responsibility of the foodservice equipment contractor. Careful review of these accessories are required as they may not all be provided by detail C-2-3B, Cutting Board w/ Bracket may be listed in the itemized specifications as an accessory to a Jade griddle. This item is not available from Jade. The foodservice equipment contractor will obtain this item from the appropriate source (custom fabricator) to fulfill the specification.

1.10 DRAWINGS

- A. The drawings which constitute a part of the contract indicate the arrangement and location of equipment. Should it be necessary to deviate from this arrangement in order to meet structural conditions, such deviation shall be made without expense to Owner.
- B. The data given herein on the drawings is reasonably exact but extreme accuracy is not guaranteed. Drawings are for the assistance and guidance of the Food Service Equipment Contractor and exact locations, distances and levels will be governed by the building. The Food Service Equipment Contractor shall accept his contract with this understanding.
- C. The following list of drawings as prepared by Clevenger Frable LaVallee, Inc. shall be considered as a part of the bidding documents and shall bear an issue date of November 1, 2021 Bid Issue KA-1,2,3,4 and 5.

1.11 WARRANTY

- A. All equipment, fixtures and materials furnished and installed shall be guaranteed against defect in workmanship and material. All repairs and replacements which may have become apparent and necessary by reasons of such defects, during the first year after final completion and acceptance of equipment installation, shall be made without cost and expense to the Owner. All such repairs and replacements are ultimately the responsibility of the Foodservice Equipment Contractor and are

ultimately the responsibility of the Foodservice Equipment Contractor and shall be made at a time and during hours satisfactory to the Owner.

- B. For all commercially manufactured equipment that has a refrigeration system and semi-hermetic compressors, furnish an additional four (4) year warranty on all compressors.
- C. Warranty period shall commence with final acceptance of installation by Owner.
- D. Components of equipment subject to replacement prior to one years use and those items which may fail due to improper or inadequate periodic maintenance by the Owner/Operator are not intended to be included within the scope of the warranty.
- E. Provide all labor, material, refrigerant, and incidental expenses to maintain the temperatures specified on all refrigeration systems. Systems to be kept in first class working condition for a period of one (1) year from date of acceptance by Owner, or the date systems are put into operation, whichever occurs first, without additional cost to the Owner.
- F. Equipment that fails to perform will be removed and replaced with items of equal value at no expense to the Owner. Work required to replace equipment that has failed to perform will be completed at the convenience of the Owner.

1.12 DISCREPANCIES

- A. Where discrepancies are discovered between the drawings and the specifications, regarding quality or quantity, the higher quality or the greater quantity is to be included in the Bid Proposal.
- B. Contractor is responsible for verifying and coordinating all items provided in this Section, with the drawings, specifications, manufacturer's requirements, submittals, actual site conditions, adjacent items, and associated (Sub-) Contractors; to assure that there are no discrepancies or conflicts. This is to include, but not be limited to, quantities, dimensions, clearances required, direction of operation, door swings, utilities, fabrication details and methods, installation requirements, etc.
- C. Contractor to notify the Architect, in writing, of any discrepancies discovered; and await written clarification prior to proceeding with the items or areas in question.

1.13 SUBMITTALS

- A. Pre-Requisite to Submittals
 1. Obtain the latest Architectural plans from the Architect. F.S.E. Contractor shall review, and the shop drawings shall be prepared to reflect, the most current set of Architectural floor plans.
 2. Confirm routing & distribution requirements with General Contractor /Construction Manager.
 3. Confirm schedule for shop drawing submittals.
- B. Submittal Content
 1. All submittals are to be presented concurrently as separate electronic files. Piecemeal submittals (i.e. cutbooks one week, custom fab the next week) will be rejected.
 2. Separate, stand alone, electronic files are to be provided for each submittal including, if applicable, cutbook submittal, dimensioned rough-in plan submittal, exhaust hood submittal, walk-in cooler submittal, custom fabrication submittal, engineered system submittal, etc.
 3. All the cutsheets are to be included in one cutbook submittal file, all dimensioned rough-in plans are to be included in one dimensioned rough-in plan submittal file, etc.

4. DO NOT BIND MULTIPLE SUBMITTALS INTO ONE FILE.

5. Files containing multiple submittals (cutbook, rough-ins, custom fabrication, etc.) will be REJECTED.

NOTE to GC's / CM's: When the Kitchen Equipment Contractor submits individual files as specified to you for submission **DO NOT BIND THEM INTO ONE FILE.**

Multiple submittals bound into one file will be rejected.

C. Quality of Submittals

1. Submittals are to be of high quality, reflecting a high degree of accuracy and consistent with the specifications and drawings. **The Foodservice Equipment Contractor will REVIEW AND STAMP shop drawings from specified manufacturers to confirm that their drawings reflect the consultant's intent prior to submitting these for the Consultant's review.** The drawings will be returned without review if the drawings are not stamped or do not reflect the Consultant's intent.
2. Drawings are to be submitted at the appropriate scale. **Shop drawings submitted that are "not to scale" will be rejected.**

D. Standard of Measurement

Submittals will conform to the standard of measurement in the country where the project is located. All submittals for projects in the U.S. will reflect U.S. measurement (feet/inches). Inches are to be represented in fractions, not decimals.

E. Incomplete/Inaccurate Submittals

1. Submittals that do not satisfy the requirements of this section will be rejected.

F. Checking:

1. Checking product data, rough-in drawings, wall backing drawings, shop drawings, and refrigeration drawings by Designer is for design concept only, and does not relieve the Food Service Equipment Contractor of responsibility for compliance with Contract Documents, verification of utilities with equipment requirements for conformity and location, verification of all dimensions of equipment and building conditions or reasonable adjustments due to deviations.
2. Drawings shall be prepared on the Food Service Equipment Contractor's sheets and by his employees. In those cases where the Food Service Equipment Contractor relies on electronic files provided by the Consultant at the request of the Owner, the Food Service Equipment Contractor is reminded of the importance of the shop drawing preparation and review phase. The availability of electronic files for purposes of expediting the submittal process is not intended to short-cut the thought process required to achieve a complete and accurate submittal.
3. Submittals require approval prior to ordering equipment or starting fabrication.

G. Mailing and Distribution:

1. After checking, distribute cutbooks and drawings as directed by the General Contractor or Construction Manager.

H. Response to Inspection List:

1. FSEC shall respond to the inspection list prepared by the Consultant within five (5) working days from receipt by either initiating corrective action to the items noted or by submitting a written report addressing the disputed items.

I. Submittal - Conformance Check

Kitchen Equipment Contractor shop drawing submittal is to conform to the following requirements

1. Product Data Sheets (Cutsheets) Checklist

After award of contract and before proceeding with the purchase of manufactured equipment, submit one (1) bound set of product data sheets. The set will consist of:

- a) Cover sheet with project name, name and contact information of KEC.
- b) Table of Contents of all items listing item names and item numbers.
- c) Submit Owner approved Alternate/ Substitution Request form for any alternates/ substitutions previously approved by the Owner.
- d) Lead sheet for all scheduled equipment items in numerical sequence by item number (1, 2, 3, 4, etc.). Including all new, existing, future and by Owner/Operator/Vendor item showing: Item number; quantity; description; manufacturer's name, address & telephone; model number; specified options & accessories & modifications; utility requirements and special notes. (See Figure 1 in appendix).
- e) Manufacturer product data sheets and/or shop drawings.
- f) Separate product data sheet submittal from other shop drawing submittals.
- g) Cutbooks must be reviewed and stamped by the KEC to indicate they conform to the submittal requirements prior to submission.

Do not cut and paste Consultants Itemized specification in the lead sheet. Cutbook submittals with incomplete or missing lead sheets will be rejected. Consultant will not review the cutbook submittal without accompanying dimensioned rough-in plans. Cutbooks submitted without dimensioned rough-in plans will be rejected.

Submittals that do not satisfy the requirements as outlined in Section 1.13 SUBMITTALS of the 114000 Foodservice Equipment Specification will be rejected.

2. Dimensioned Rough-in Shop Drawings Checklist:

- a) Submit 1/4" scale rough-in drawings for checking that reflect the final architectural background(s) requested and obtained from the Architect.
- b) Show dimension, ventilation requirements, floor and wall sleeves, plumbing, gas, steam, and electrical connections for food service equipment, including all equipment items supplied by the Owner, Product Suppliers, Operator, etc. on drawings.
- c) Size and locate concrete pad dimensions, depressions and special conditions as required for equipment.
- d) Prepare elevations and sections of special work for use of the respective trades.
- e) Represent building conditions that affect the installation or performance of food service equipment items on drawings.
- f) The following shall each be drawn on separate sheets and/or plans: Equipment Plan; Plumbing; Electrical; Building Works & Ventilation; Refrigeration and Beverage Systems.

- g) Tag utility connections and reference to a schedule of utility requirements using the same item number assigned by the Food Service Consultant. For example, Item 13, Mixer on the Consultant's plan becomes E-13 on the dimensioned electrical rough-in plan and P-13 on the dimensioned plumbing rough-in plan.

Submittals that do not satisfy the requirements as outlined in Section 1.13 SUBMITTALS of the 114000 Foodservice Equipment Specification will be rejected.

3. Wall Backing Shop Drawings Checklist:

- a) Verify wall construction type. Wall backing not be required on masonry wall construction.
- b) Wall backing is required for items that are wall mounted as noted on CFL standard detail C-1-2A
- c) Show location, size and dimension of all wall backing required include detail sheet C-1-2A. Any backing required will be provided and installed by the General Contractor.
- d) Building Works Plan must be submitted for checking and forwarded to the General Contractor in time for the wall backing to be installed prior to closing of the walls.

Submittals that do not satisfy the requirements as outlined in Section 1.13 SUBMITTALS of the 114000 Foodservice Equipment Specification will be rejected.

4. Fabricated Shop Drawings Checklist:

- a) Submit Owner approved Alternate/ Substitution Request form for any alternates/ substitutions previously approved by the Owner.
- b) Prepare and submit shop drawings for all custom fabricated items included in this contract.
- c) The detail drawings shall be submitted at a minimum of 3/4" scale for elevations and 1-1/2" scale for sections and on a minimum sheet size of 24" x 36".
- d) Drawings shall show all dimensions, all details of construction, installation, and relation to adjoining and related work.
- e) Drawings shall show all reinforcements, anchorage and other related work required for the complete installation of all fixtures.
- f) Fabrication details and section drawings shall be prepared to reflect "worst case" conditions and illustrate close tolerances.
- g) Fabricated shop drawings shall be consistent with the bidding documents. Any variances that may require changes to the building utility systems should be discussed with the Designer prior to submission.
- h) Fabrication drawings shall show manufacturer, model number and all equipment items, including those of other manufacturers, drawn to scale. For example, elevation drawings of counters with undercounter equipment shall show item number, manufacturer and model number of undercounter equipment drawn to scale.
- i) When custom stainless and or custom millwork counters for cafeteria serving areas are included in the KEC scope of work, the Foodservice Equipment Contractor is required to provide a complete set of fully coordinated shop drawings representing all equipment and materials provided by multiple manufacturers including millwork

or stainless steel counters, stone or composite counter tops and all foodservice equipment items. As part of the shop drawing submittal process, the FSE Contractor will provide a fully coordinated set of custom stainless and / or custom millwork shop drawings reflecting all items "In Contract" and related items "Not in Contract". Those parties providing any equipment "Not in Contract" will be responsible for submitting product data/ shop drawings for specific items they are providing. The Food Service Equipment Contractor will be responsible for obtaining and reflecting those requirements in the fabricated shop drawing submittal. The drawing set should include a floor plan identifying all units and their relationship to one another, plan details for each item at a scale of $\frac{1}{2}'' = 1'-0''$, elevation drawings at $\frac{3}{4}'' = 1'-0''$ and sections/detail drawings a $1 \frac{1}{2}'' = 1'-0''$ identifying:

1. Dimensions and locations of all countertop cut-outs for drop-in equipment and related equipment flanges.
2. The overall dimension that drop-in equipment units extend below the countertop.
3. The exact size and locations of all food shields. Size and locate all uprights relative to counter and adjacent equipment units.
4. Where counters contain countertop mounted units, identify the size and location of same.
5. The relationship of all items "In Contract" to items "Not in Contract".
6. Cut-outs for remote controls, utility routing, access to drains, ventilation requirements, etc.
7. Details of food shield mounting requirements.
8. Details of food service equipment installation in stone or composite countertops, if applicable, consistent w/ the manufacturer's recommendations including a plan view of joints proposed for stone or composite tops.

Where cafeteria service counters (referenced above) or other Millwork assemblies (including, but not limited to bar die & top, back bar, service stations, millwork buffet units, etc.) are not in the F.S.E. Contractor's scope of work, the F.S.E. Contractor will provide product data on those "in contract" items that relate to the millwork assemblies being provided by Others sufficient to enable Others to prepared by others they will be submitted to the F.S.E. Contractor for review and coordination. Fully coordinated shop drawings, satisfying the requirements outlined above, will then be submitted to the Architect for review and approval.

- j) Shop drawings submittals are to reflect all standard details specified by the Consultant. Consultant approval of shop drawings does not preclude the Foodservice Equipment Contractor from providing the details specified.
- k) For self-contained refrigeration systems located within cabinet body construction, confirm the recommended free area of ventilation with the manufacturer and coordinate the location of the ventilation louvers with the custom fabricator.

- l) All custom fabricated equipment items are to be accounted for in the drawing submittal.
- m) Confirm that all built-in utilities (plumbing and electrical) are accounted for and minimize their impact on storage and functionality.
- n) Only Approved Certified Fabricators/Installers as listed by the Solid Surface Material Manufacturer **will be accepted**.
- o) Drawings must be reviewed and stamped by the KEC to indicate that they conform to the submittal requirements prior to submission.

Submittals that do not satisfy the requirements as outlined in Section 1.13 SUBMITTALS of the 114000 Foodservice Equipment Specification will be rejected.

5. Exhaust Hood Shop Drawings Checklist:

- a) Submit Owner approved Alternate/ Substitution Request form for any alternates/ substitutions previously approved by the Owner.
- b) Shop drawings submitted for exhaust hoods are to reflect exhaust/ make-up air data represented on the “plans and specifications” including identical duct collar quantities, size and location, CFM requirements and static pressure. Drawings submitted for approved substitutions or drawings from alternate manufacturers listed as “equal” in the item specification of this document are not excluded from this requirement.
- c) Fabrication drawings shall show manufacturer, model number and all equipment items, including those of other manufacturers, drawn to scale. For example, elevation drawings of exhaust hoods shall show manufacturer, model number and cooking appliances drawn to scale.
- d) Note that duct and fan systems will not be re-engineered to conform to shop drawings showing different exhaust/ make-up air data than those specified. See Part I – General, 1.7 Alternates, E.
- e) Account for all scheduled items.
- f) When specified, pre-piping of the fire suppression system must be shown.
- g) Provide elevations showing all equipment units below the exhaust hood.
- h) Provide wiring schematic for fire suppression system, if provided by exhaust hood manufacturer.
- i) Provide the “sequence of operation” in the event of a fire under the exhaust hood.
- j) Size and locate any remote control panels on the drawing.
- k) Drawings must be reviewed and stamped by the KEC to indicate that they conform to the submittal requirements prior to submission.

Submittals that do not satisfy the requirements as outlined in Section 1.13 SUBMITTALS of the 114000 Foodservice Equipment Specification will be rejected.

6. Food Shield Shop Drawings Checklist:

- a) Shop drawings shall show manufacturer, model number and all equipment items including those of other manufacturers drawn to scale.
- b) Submit Owner approved Alternate/ Substitution Request form for any alternates/ substitutions previously approved by the Owner.
- c) Account for all food shields in the submission.
- d) Drawings must be consistent with design intent regarding on/off controls for lighting and heat lamps when specified.
- e) Show all details and wiring diagrams for any transformers and related utility connections.
- f) Provide finishes, options, and accessories and mounting details.
- g) Drawings must be reviewed and stamped by the KEC to indicate that they

conform to the submittal requirements prior to submission.

Submittals that do not satisfy the requirements as outlined in Section 1.13

SUBMITTALS of the 114000 Foodservice Equipment Specification will be rejected.

7. Floor Trough Shop Drawings Checklist:

- a) Specify the manufacturer and model numbers on the submittal.
- b) Submit Owner approved Alternate/ Substitution Request form for any alternates/ substitutions previously approved by the Owner.
- c) Account for all floor trough units in the submission.
- d) Specify all gauges, finishes, options, accessories and details.
- e) Confirm that the flange detail provided is consistent with the finished flooring proposed by the Architect. Drawings to represent special "sandwich" flange requirement for sheet good flooring, when specified by the Architect.
- f) Drawings must be reviewed and stamped by the KEC to indicate that they conform to the submittal requirements prior to submission.

Submittals that do not satisfy the requirements as outlined in Section 1.13

SUBMITTALS of the 114000 Foodservice Equipment Specification will be rejected.

8. Walk-In Cooler Shop Drawings Checklist:

- a) Specify the manufacturer and model numbers on the submittal.
- b) Submit Owner approved Alternate/ Substitution Request form for any alternates/ substitutions previously approved by the Owner.
- c) Confirm that the floor details shown are consistent with the specifications.
- d) Properly dimension fixtures (L x W x H)
- e) Confirm options and accessories to those specified.
- f) Confirm that the refrigeration systems submitted, if provided by the walk-in manufacturer, are consistent with the specification.
- g) Drawings must be reviewed and stamped by the KEC to indicate that they conform to the submittal requirements prior to submission.
- h) Note that no horizontal sliding doors w/ floor mounted stay wheels will be accepted.

Submittals that do not satisfy the requirements as outlined in Section 1.13

SUBMITTALS of the 114000 Foodservice Equipment Specification will be rejected.

9. Refrigeration Rack Shop Drawings Checklist:

- a) Drawings and specification sheets with refrigeration piping showing actual line sizes and system allocation, evaporators, compressors, condensers, and required valves and accessories.
- b) All items identified, including model, any required electrical characteristics and BTU load as applicable.
- c) Submit Owner approved Alternate/ Substitution Request form for any alternates/ substitutions previously approved by the Owner.
- d) Confirm that the rack accounts for all the refrigeration loads specified.
- e) Dimension the refrigeration rack (L x W x H) properly, including service and ventilation clearances.
- f) Confirm options and accessories to those specified.
- g) Confirm that the drawing properly accounts for field wiring and identifies those responsible, consistent with the specification.
- h) Confirm that emergency power is detailed properly when specified.
- i) Submit manufacturer's drawings and manufacturer's specification sheets for approval prior to commencing work.
- j) The drawings must be reviewed and stamped by the KEC to indicate that they conform to the submittal requirements prior to submission.

Submittals that do not satisfy the requirements as outlined in Section 1.13
SUBMITTALS of the 114000 Foodservice Equipment Specification will be rejected.

- J. Solid Surface Materials Shop Drawings
 - 1. Only Approved Certified Fabricator/Installers as listed by the Solid Surface Material Manufacturer **will be accepted**.
 - 2. The Food Service Equipment Contractor must provide drawings detailing the fabrication and installation methods of the food service equipment in the solid surface material.

1.14 PARTS AND SERVICE MANUALS

- A. Furnish two (2) bound sets of parts and service manuals.
 - 1. The manual shall include a table of contents in numerical sequence referencing item number and item name.
 - 2. The manuals shall include a source directory for parts and service for all items.
 - 3. The manuals shall be submitted in time to allow review and transmittal to the Owner/Operator prior to start-up and demonstration of the equipment. Manuals must be submitted before the Owner will issue final acceptance of the installation.
- B. Furnish "As - Built" plans of foodservice areas. Note that all submittals must be revised through the course of completing the project to reflect all as built conditions.

1.15 VERIFICATION AND COORDINATION OF PROJECT/DATA

- A. Range Lines:

All front manifold range lines shall be assembled and aligned at the factory before shipment, including back guards, high shelves and salamanders.
- B. Pans and Inserts
Verify sizes directly w/ the Owner/Operator on the following representative items before ordering equipment relating to these items:
 - a) Steam Pans
 - b) Sheet Pans
 - c) Trays
 - d) Glass and Cup Racks
 - e) Plate Sizes
 - f) Cup Sizes

Include verification of tray orientation and spacing at locations of soiled tray return areas, tray make-up areas, etc.
- C. Color selections "By Architect" upon contract award submit a listing of those items requiring "color selection by Architect" directly to the architect along with information from the manufacturer including color charts, detailing the choices available.
- D. Quietness of Operation
Quietness of operation of all food service and refrigeration equipment is a requirement. Remove or repair any equipment producing objectionable noise.
- E. Delivery and Entry
Verify all conditions at the building, particularly door openings, stairwells, elevator cab sizes and passageways prior to submitting your proposal. Foodservice Equipment Contractor proposals are to include the costs associated with delivery access to satisfy the intent of the design. The cost of manufacturing equipment in multiple sections and providing welded field joints (non-welded spline joints not

acceptable), as may be required to enable delivery, are to be included in the proposal. All special equipment, handling charges, window removal, equipment substitution, etc. included in change order requests related to delivery access that should have been known to the Foodservice Equipment Contractor prior to contract award will be rejected.

Coordinate access with the General Contractor to insure delivery of equipment to the required areas. Coordination shall include, but not be limited to, early delivery, hoisting, window removal and/or delay of wall construction.

F. Connection Terminals

All equipment will be complete with standard connections as they relate to their Country of Origin. It shall be the responsibility of the Food Service Equipment Contractor to provide any and all required adaptors to assure the proper connection to the conditions at the job site.

G. Site Verification

Notify Designer, Owner and the General Contractor in writing if, in the Food Service Equipment Contractor's opinion the job site is not adequate to insure proper installation of the equipment. Notification shall be in writing with sufficient time to effect corrective measures to meet the installation schedule.

H. Cold Storage Rooms and Refrigeration Systems

1. Coordinate the timely installation of the wearing floors inside the cold storage rooms with the General Contractor to prevent prolonged exposure of the floor insulation.
2. Confirm that the cold storage rooms are not used by any other trade for storage or work areas. Repair or replace any damaged areas of the cold storage rooms, if the damage was caused due to the cold storage rooms being used for storage or work areas.
3. Be responsible for determining the acceptability of the location of the remote refrigeration condensing units in regard to ambient temperature, noise and accessibility. If the condensing unit location is determined to be unacceptable for any reason, advise Owner and request direction in writing.

I. Millwork Coordination

1. Coordinate with the Millwork Contractor by providing the following information to the Millwork Contractor prior to the preparation of their millwork shop drawings:
 - a) Provide equipment sizing information for all foodservice equipment relating to millwork items.
 - b) Provide cut-out dimensions for all equipment units that drop-in or are built into the counter tops, counter aprons, etc.
 - c) Identify dimensions/clearances required between heated drop-in units and adjacent cabinet body millwork.
 - d) Carefully coordinate the locations of controls for ease of employee access.
 - e) For self-contained refrigeration systems located within the millwork cabinet body confirm the recommended free area of ventilation with the manufacturer and coordinate the location of the ventilation louver(s) with the Millwork Contractor.
 - f) Ship units of equipment that impact dimensions and construction of millwork to the Millwork Contractor.
 - g) Refer to 1.11, H. 5 and 6 for additional requirements.

PART 2 - PRODUCTS

2.1 COMMERCIALY MANUFACTURED EQUIPMENT

- A. All items of standard equipment shall be the latest model at time of delivery.
- B. Manufacturer's directions shall be followed in cases where the manufacturers of articles used in this contract furnish directions or prints covering points not shown on the drawings or specifications.
- C. All doors shall be hinged as shown on plans.
- D. Refrigerated Items
 - 1. All reach-in refrigerators and freezers with remote refrigeration systems shall be complete with condensate evaporator when no floor drain is available.
 - 2. When a condensate evaporator is required, it shall be complete with thermostatic expansion valves at the evaporator.
 - 3. Refrigerated drawer units are to be provided with stainless steel drawer liners and stainless steel full size pans. Food Service Equipment Contractor to furnish each drawer with two (2) 12" x 20" x 4" deep 18 ga. stainless steel pans.
 - 4. When a removable plate rail/cutting board is specified for an equipment stand, the Food Service Equipment Contractor is to coordinate cutting board support locations with work top cooking appliances to provide access for operations and service.
 - 5. The refrigerant for medium and low temperature fixtures to be CFC free and conform to the Montreal Protocol Agreement.
 - 6. All refrigerated fixtures are to be provided with a flush mounted exterior thermometer.
 - 7. All refrigeration Systems to be provided with 5 year compressor warranty and 1 year service agreement.
 - 8. Doors/drawers on refrigerated fixtures are to be provided with cylinder door locks, keyed alike to the extent possible, unless specified with a alternate locking devise.
 - 9. All glass panels provided as part of refrigerated display cases are to be made of insulated glass.
- E. Free-standing work tables and counters with flanged feet shall be secured to the floor with smooth head stainless steel fasteners or with pins concealed in all legs of the table/counter, when specified.
- F. All equipment units that "pass thru" wall openings are to have an "equal" finish on front and rear. The intent is that the equipment unit will project a finished "look" on the rear (kitchen side) as on the front (customer side).

- G. Provide water treatment units/systems (including surge tanks) for installation by the Plumbing Division suited to the application and anticipated volume for items “in contract” and those units provided “by vendor”, “by product supplier” or “by owner” as follows:

Postmix beverages:

Low to medium volume:

Coldrink Single PF EV9293-21 with 7FC EV9692-61 cartridge\

High volume:

Coldrink Twin PF EV9293-22 with two each 7FC EV9692-61 cartridges

Coffee:

Low to medium volume:

Insurice Single PF EV9293-01 w/ (1) EV9692-31 4FC-S cartridge

High volume:

Insurice Twin PF EV9293-22 w/ (2) EV9692-71 7FC-S cartridges

Ice makers:

Ice Cubers:

Less than 650#/day (except Hoshizaki): Insurice Single PF-I2000 EV9324-21

Hoshizaki up to 650#/day: Insurice Twin PF-I2000 EV9324-22

800# - 1200#/day (except Hoshizaki): Insurice Twin PF-I2000 EV9324-22

Hoshizaki 800# - 1300#/day: Insurice Triple 7FC-S EV9327-74

1300# - 1600#/day (except Hoshizaki): Insurice Triple 7FC-S EV9327-74

All cubers greater than 1600#/day (and Hoshizaki greater than 1300#/day):

Insurice Quad 7FC-S EV9327-44

Ice Flakers/Nugget:

Less than 650#/day: Insurice Single PF-I2000 EV9324-21

650# - 1000#/day: Insurice Twin PF-I2000 EV 9324-22

1200# - 2000#/day: Insurice Triple 7FC-S: EV9327-73

Combination:

Less than 3.33 gpm – High Flow CSR Twin EV 9330-42

3.33 – 7.5: High Flow CSR Triple 7FC EV9329-73

Up to 10 gpm: High Flow CSR Quad 7FC EV EV9329-74

Up to 15 gpm: Endurance Quad High Flow EV9437-32

Up to 15 gpm: Endurance Self-Clean High Flow EV9437-42

Steams (boiler only):

Countertop and floor less than 1.67 gpm: Kleensteam CT EV9797-50

Less than 2.5 gpm: Kleensteam EV9797-21

Flow rates less the 5gpm Kleensteam II Twin EV9797-22

Provide wall mounted rack per detail C-19-4 when surge tank is wall mounted.

Provide suitable sized dunnage rack for floor mounted surge tank.

Provide three sets of filters for the system provided, that's one set for the system to operate & two sets of filters for back-up/replacement.

- H. Food Service Equipment Flexible Connectors
1. Gas Cooking Equipment Connections: FSE Contractor shall furnish gas cooking appliances with appropriately sized (length, diameter and BTU capacity) Dormont Safety System gas connector assemblies.
 - a. Gas appliances (movable and non- anchored stationary)
Dormont Series 16xxKITCF2S inclusive of: Gas connector, 2 Swivel Max Swivels, coiled restraining cable and hardware, and SafetyQuik combination valve/quick disconnect.
 - b. Gas appliances (Floor anchored Stationary)-
Dormont Series 16xxBP connector.
All gas connection devices shall be CSA and NSF compliant.
 2. Appliances requiring water supply
 - a. Counter top Equipment
FSE Contractor shall supply countertop coffee brewing and dispensing equipment with Dormont SwirlHose retractable connectors including 2-way water quick disconnect. Sizing in diameter and length shall be sufficient to GPM requirements of appliance and length to the water source. NSF Approved. This includes equipment "in contract", and those items "by vendor", "by product supplier" or "by owner".
 - b. Cooking equipment with water supply required-
FSE Contractor shall supply Dormont Series WxxBP2Q connectors inclusive of the connector and a 2 way water quick disconnect on all movable and non anchored equipment requiring a water feed. (Cold or Hot) Size shall be determined based on GPM requirements and proximity to water source. Wheeled (castered) equipment will require appropriately sized coiled restraining device. Dormont series: RDC.
 - c. Cooking appliances with steam supply required-
FSE shall supply Dormont Series HxxBIP2Q connectors inclusive of the connector and a 2 way quick disconnect on all movable and non anchored equipment requiring a steam feed. Connector steam source. Wheeled (castered) equipment will require appropriately sized coiled restraining device. Dormont series: RDC
 3. Remote Refrigeration, Mobile Units.
When specified, FSE Contractor shall provide and make final connection to remote refrigerated fixtures with flexible pull-out assemblies for refrigerant from Packless Industries. Units fabricated of red brass tubing with continuous helical corrugation covered by bronze braid. Standard models have an SAE male flare at one end and an SAE female flair swivel of the same size at the other end. U.L. and C.S.A. approved. Provide pull-out assemblies of diameter, length (custom, if required) and connector type as recommended by the manufacturer for each application.
 4. Positioning Devices
When required by Authority having jurisdiction, mobile (wheeled) cooking equipment shall be held in position utilizing the Dormont Safety-Set device. Dormont: part # PS.
 5. Division 23 to connect all quick-disconnect hoses for water and gas to equipment.

I. Buy Out Equipment

The following is a list of standards for all "buy out" equipment:

1. The intent is that exposed metal surfaces of buy-out equipment units have a Stainless steel finish except where the model number of the unit dictates aluminum. For those items where stainless fronts, tops, rears and sides are "optional" we expect that a stainless finish will be provided in those areas where the finish is exposed.
2. All range units if not provided with a rear riser as a standard component by the manufacturer are to be provided with a stub back (min.).
3. Provide any/all stacking/mounting kits as may be required per the manufacturers recommendations for stacking equipment units together (for example: ice makers positioned on top of soda/ice dispensers), built-in/drop-in units into custom fabricated fixtures, etc.
4. Accessories may be required that are not available from the manufacturer of the specified equipment. The Food Service Equipment Contractor shall provide those accessories as separate items. As an example, a Jade JGT-2436 griddle may be specified with a cutting board and support bracket per detail C-2-3B. This support bracket specified is not available from Jade. It needs to be custom fabricated. The cost of the cutting board and support bracket needs to be included in the price of the griddle in the Food Service Equipment Contractor's proposal to the Owner. A thorough review of all accessories specified is necessary to properly account for their cost and avoid schedule delays.
5. Size casters for proper fit of undercounter equipment units at no additional cost to the Owner.

2.2 PLUMBING WORK

- A. Provide suitable pipe slots, chases and/or do all drilling, punching and cutting of equipment required to provide access for Division 22 - Plumbing connections and/or runs. Such work performed at the job site shall be of the same quality as similar work in the shop.
- B. To insure proper clearance for cleaning, all horizontal piping lines shall be run at the highest possible elevation and not less than 6" (150 mm) above floor, through equipment wherever possible.
- C. Indirect waste piping shall be installed in accordance with the codes in effect at the job site. Piping shall run as described hereinafter, and shall discharge into floor sinks. Extend piping to a point of at least 2" (50 mm) above rim of floor sink and cut bottom on 45 degree angle. All indirect waste piping shall be installed and routed in a manner to insure proper drainage and shall conform with shelves, spaces, equipment or building conditions. Secure all indirect waste piping as required to achieve same.
 1. Indirect waste piping from ice bins, ice pans and similar items shall be insulated to prevent condensation.
- D. Water inlets shall be located above the positive water level to prevent siphoning of liquids into the water system. Wherever conditions shall require a submerged inlet, a suitable type of check valve and vacuum breaker shall be placed on the fixture to form part of same to prevent siphoning.
- E. Where exposed, piping and fittings shall be chrome plated.
- F. All valves shall be American made to insure availability of replacement parts.

G. FAUCETS

1. Faucets shall be furnished on all sinks, bain maries, water stations and other fixtures as specified and shall be supplied with non-splash aerator, and water saving devices where required by local codes. Unless otherwise specified, faucets shall be provided as follows, for installation by Division 22 - Plumbing: (Note: All faucets to be from the same manufacture).

Type 1: Faucet (1/2 Splash)
Fisher Model 3251 (8" Spout)*
T&S Model B—0231 with #60 x (8" Spout)

Type 2: Faucet (3/4 Splash)
Fisher Model 5414 (14" Spout)
T&S Model B-0290 (12" Spout)

Type 3: Faucet (1/2 Deck)
Fisher Model 3311 (8" Spout)*
T&S Model B-1121 (8" Spout)

Type 4: Faucet (3/4 Deck)
Fisher Model 5314 (14" Spout)
T&S Model B-0293 (12" Spout)

Type 5: Faucet (1/2 Deck)
Fisher Model 1821 (Gooseneck)*
T&S Model B-1142 (Gooseneck)

Type 5A: Faucet (1/2 Splash)
Fisher Model 1945 (Gooseneck)*
T&S Model B-0331 (Gooseneck)

Type 5B: Faucet (1/2 Deck)
Fisher Model 3525

Type 6: Faucet (1/2 Deck)
Fisher Model 3010 (INDEX HOT)
T&S Model B-207 (INDEX-HOT)

Type 7: Pre-Rinse Faucet (1/2 Splash)
Fisher Model 2210-WB
T&S Model B-0133B W/Wall Bracket

Type 7A: Pre-Rinse Faucet (1/2 Deck)
Fisher Model 2310-WB
T&S Model B-0113 W/Wall Bracket

Type 8: Fill Faucet (1/2 Wall) Double Jointed Swing Sprout
Chicago Model 515 (INDEX COLD)
T&S Model B-592

Type 9:	Dipperwell & Faucet Fisher Model 3041 Component Hardware Model K27-1010
Type 10:	Water Fill Faucet & Drain Pan Fisher Model 1400 Component Hardware Model K27-1000
Type 11:	Pre-Rinse Add On Faucet Fisher Model 2901 add-on faucet.* T&S Model B- 155 ADD-ON-FAUCET
Type 12:	Glass Rack Fill Faucet (1/2 deck- hot/cold water) Fisher Model 1117-WB with #82104 Single Deck Dual Control Valve
Type 13:	Not Assigned
Type 14	Faucet (1/2 Deck) Fisher Model 3525 (Gooseneck) T&S Model B-1141 (Gooseneck)
Type 14A:	Faucet (1/2 Splash) Fisher Model 1996 (Gooseneck) T&S Model 1146 (Gooseneck)
Type 14B:	Faucet (1/2 Deck) at Fabricated Hand Sink Located in Worktop Fisher Model 3526 (Gooseneck) T&S Model B-1141 with #120x Rigid Gooseneck & #B-0413 Adaptor
Type 15:	Faucet (1/2 Deck) at Fabricated Hand Sink Located Below Worktop T&S Model -0202
Type 16:	Fill Faucet (1/2 Wall) at Range Spreader Fisher Model 3710 (INDEX COLD) T&S Model B-0212 (INDEX COLD)

*Size spout to position water flow at center of waste connection.

H. DRAINS AND WASTES

1. Furnish all necessary drains and wastes with the equipment as follows:

Type 1: Drain (1-1/2" & 2") - Rotary handle without overflow, flat strainer. Fisher Model 28932

Type 2: Drain (1-1/2" & 2") - Basket Strainer without overflow, basket strainer. Fisher Model 28983.

Type 3: Drain (1-1/2") - Drain with standpipe. Fisher Model 6541-2400 waste socket, 6550-2100 lock nut, 6580-5000 tail piece and 6571 standpipe (length as required)

Type 4: Drain (1") - Drain with standpipe. Fisher Model 6240-2100 waste socket with 6280-5000 washer, 6250-2100 lock nut and 6271 standpipe (length as required).

Type 5: Drain (1-1/2") - Open. Fisher Model 6541-2400 waster socket, 6550-2100 lock nut, 6580-5000 washer and 6544-0000 tail piece.

Type 6: Drain (1-1/2" & 2") - Rotary handle with overflow, flat strainer. Fisher Model 28940 (verify length and height of overflow assembly with sink size).

Type 7: Drain (1-1/2" & 2") - Rotary handle with overflow and basket strainer. Fisher Model 28959 (verify length and height of overflow assembly with sink size).

2. All rotary wastes/lever wastes are to be provided with a # 14 ga. stainless steel valve bracket located a sink bowl front. Refer to Detail C-8-5 for construction.

3. Unless specified otherwise, all custom fabricated sinks (except hand sinks) are to be provided with Type 1 wastes. Custom fabricated hand sinks are to be provided with Type 2 wastes.

- I. Food Service Equipment Contractor to coordinate plumbing interconnections at field joints, completed by Division 22 - Plumbing, on equipment assembled at the job site.

J. Floor Troughs

1. When specified, floor troughs are to be properly dimensioned on the F.S.E.C.'s building works rough-in plan. Careful coordination is required so that trough grate removal is unobstructed by adjacent equipment units. Further, where troughs are specified in front of tilting units (braising pans, kettles), the equipment is to be placed so that the center of the pour path on the tilting unit aligns with the center line of the trough. Food Service Equipment Contractor to provide trough flange type best suited to accommodate finished flooring specified by Architect.

2.3 ELECTRICAL WORK

- A. For all fabricated equipment, furnish and install all outlets, switches, controls, conduit, service fittings and load centers. Load centers shall be complete with

- individual "visi-trip" circuit breakers for each device built into or forming an integral part of the unit. Furnish to Division 26 - Electrical a wiring schematic including circuit breaker diagram for load center.
- B. Insure that all equipment furnished under this contract shall be so wired, wound or constructed as to conform with the characteristics of electrical and other services at the premises.
- C. Appliances shall be new, of manufacturer's current production and furnished complete with motors drive mechanism, starters and controllers, including master switches, timers, cut-outs, reversing mechanism and other electrical equipment if and as applicable. Wiring and connection diagrams shall be furnished with electrically operated machines and for all fabricated equipment.
- D. Only rigid steel conduit shall be used, zinc coated where unexposed and chrome plated where exposed. All conduit wiring shall be run concealed wherever possible. Conduit shall be continuous from outlet to outlet and from outlet to load center circuit or pull boxes and shall enter and be secured in such a manner that each system shall be electrically continuous throughout. All conduits shall be thoroughly and substantially supported by accepted industry practices.
- E. Supply on each motor driven appliance or electrical heating unit, a suitable control switch or starter of proper type wherever such equipment is not provided with same.
- F. All plug-in equipment, shall have plugs and neoprene cords furnished and installed. Coordinate work with Division 26 - Electrical so that the receptacles provided will match the specific plugs installed as part of the plug-in equipment. Any changes on cords and plugs required in the field due to lack of coordination between Division 26 - Electrical and Food Service Equipment Contractor shall be the latter's responsibility.
- G. All surface mounted receptacles indicated for fabricated equipment are to have Component Hardware Group, Inc. model R58-1010 or R58-1029 or equal aluminum box complete with satin finish stainless steel cover and receptacle as indicated below:
1. 2-pole, 3-wire grounding 20 amp; 125V.
Hubbell #5352 or equal (NEMA 5-20R).
 2. 2-pole, 3-wire grounding 20 amp; 250V.
Hubbell #5461 or equal (NEMA 6-20R).
 3. 2-pole, 3-wire grounding 30 amp; 250V.
Hubbell #9330 or equal (NEMA 6-30R).
- H. All built-in receptacles indicated for fabricated equipment are to be 2" x 4" x 1-1/2" deep "Handy Box" tack welded to fixture and fitted with receptacle indicated above and satin finish stainless steel cover. Splash mounted receptacles to be horizontal with all others vertical.
1. 30 AMP, 250 V receptacles require a 2-1/8" deep "Handy Box". If splash mounted, increase splash width to 2-1/2".
- I. All switches, controls, etc., shall be conspicuously labeled as to use with phenolic plastic name plates screwed to adjacent surfaces, with white recessed lettering on black background. Submit a sample to the Designer for approval.
- J. All electrically heated, fabricated equipment shall be internally wired to a thermostatic control and an "on/off" red neon light indicator, both to be mounted in a terminal box with a removable access panel and located outside the heated area. Wiring to be nickel-plated copper, properly insulated.

- K. All cold storage room electrical components shall be provided with conduit, splice boxes, switches, fittings, etc. concealed within the insulated panels at time insulation is foamed in place. Conduit shall extend up within wall panels, through ceiling panels ready for EYS fittings and final connection by Division 26 - Electrical.
 - L. Provide all incandescent bulbs and fluorescent tubes required for equipment under this section. Fluorescent tubes, for food service display equipment, to be high natural color fluorescent lamp "Color-Gard 50" as manufactured by Duro-Test Corporation 1-800-937-0900 ext 7020 (or equal).
 - M. Food Service Equipment Contractor to coordinate electrical interconnections, completed by Division 26 - Electrical, at field joints on equipment assembled at the job site.
 - N. All wiring within custom fabricated counters and tables to be concealed. Wiring to heat lamps and display lighting (Part of food shield assembly) to be concealed.
- 2.4 FOOD SERVICE EQUIPMENT (COMMERCIAL & FABRICATED)
- A. Lamps
Food Service Equipment Contractor shall furnish all lamps as recommended by the manufacturer, or as specified, required for all food service equipment light fixtures. Lamps will be installed by Division 26 - Electrical.
 - B. Cutting Boards
All cutting boards provided for "buy-out" and custom fabricated equipment to be manufactured by Richlite. For custom fabricated application provided the size and thickness as indicated in the documents. For "buy-out" items provide same size and thickness as would otherwise be provided by the manufacturer of the "buy-out" item.
- 2.5 MOUNTING HEIGHTS FOR FOOD SERVICE EQUIPMENT
- A. Wall Shelving
Confirm mounting height of all wall mounted food service equipment with Owner's representative prior to installation.
 - B. Fire Suppression System
Fire Suppression System tank/control cabinet to be mounted tight to finished ceiling at location shown on plan.
- 2.6 VENTILATION WORK
- A. Provide all labor, material and services required; verify sizes and locations of duct connections; and provide all exposed duct work from hoods, ventilators, and dishwashers to 4" above finished ceiling for final connection to building duct work by division 23 - HVAC.
 - B. All exposed ducts etc. to be stainless steel.
 - C. Food Service Equipment Contractor to verify field conditions and provide and install matching trim and closure panels (as required) to close gaps between exhaust hoods, adjacent walls and ceilings. All trim and closure panels to be provided by ventilator manufacturer.
 - D. Provide stamped and sealed drawings for exhaust hoods and fire suppression systems when required by the authority having jurisdiction.

2.7 FABRICATED EQUIPMENT

Following is a list of approved manufacturers for custom fabrication. **Bidders must provide pricing in their base bid for the specified manufacturer and any mandatory alternate manufacturer as listed in the individual item specifications for each custom fabricated item. Manufacturers not specified in the item specification section must be submitted as an alternate. See 1.7 Alternates/ Substitutions.**

All State Fabricators Corp	Cranston, RI	(401) 785-3900
Carbone Metal Fabricator	Chelsea, MA	(617) 884-0237
FSF Manufacturing, Inc.	Oviedo, FL	(407) 971-8280
Low Temp Manufacturing Co.	Jonesboro, GA	(770) 478-8803
Pro Stainless, Inc.	Keyser, WV	(304) 788-5041
South Jersey Metal (SJM)	Deptford, NJ	(856) 228-0642

No alternates to the manufacturers listed above will be accepted.

Following is a list of approved manufacturers for food shields. **Bidders must provide pricing in their base bid for the specified food shield manufacturer and any mandatory alternate manufacturer listed in the individual item specifications for each food shield item. Manufacturers not specified in the item specification section must be submitted as an alternate. See 1.7 Alternates/ Substitutions.**

BrassSmith	Denver, CO.	(800)-662-9595
Versa Gard	Norcross, GA.	(404)-248-9200
Premier	Atlanta, GA	(800)-251-5800

No alternates to the manufacturers listed above will be accepted.

NOTE: Approved Millwork Fabricators: See section 2.8

- A. Special Fabricated Equipment
All specially fabricated equipment must be by one manufacturer acceptable to Designer and the Owner.
- B. Workmanship
All work must be done in an approved workmanlike manner to the complete satisfaction of Designer and the Owner.
- C. Stainless Steel
All stainless steel shall be the U.S. standard gauge, 18-8, type 304, finish as noted in paragraph 2.05N.
- D. Galvanized Steel
All galvanized steel shall be electro-galvanized.
- E. Welding and Soldering
 - 1. All seams and joints shall be shop welded or soldered as the nature of the material may require. Welds to be ground smooth and polished to match original finish.
 - 2. Framework of galvanized steel shall be welded construction. Where galvanizing has been burned off, the weld shall be touched up with high grade aluminum paint.
- F. Sound Deadening
 - 1. The underside of all metal top tables, counters, drainboards, sinks and dishtables shall be provided with sound deadening material similar to Component Hardware Model Q85-5225 Tacky Tape; 3/4" wide x 3/32" thick strips. Spray or painted material or exposed mastic will not be acceptable.
- G. Metal Top Construction
 - 1. All seams and joints shall be one-piece welded construction, reinforced on the underside with galvanized steel secured to top with weld studs and stainless steel or chrome plated cap nuts so tops can support heavy weight

- without deflection. Cross braces to be not more than 48" (120 cm) on center.
2. Tops supporting coffee urns, ice/soda dispensers, Etc...shall have additional bracing to support the heavy loads.
 3. Field joints in stainless steel tops; where required due to limitation of sheet sizes, equipment sizes or installation requirements shall be welded, ground smooth and polished to blend with adjacent surfaces.
 4. If inverted hat sections are used in lieu of channels, close ends.
- H. Fasteners
1. Exposed bolt heads will not be permitted on fixtures.
 2. Butt joints made by riveting straps under seams and then filled with solder will not be accepted.
 3. Rivets of any kind, including pop-rivets, will not be accepted.
 4. Exposed screw heads, when necessary, shall be one of the same material as the pieces joined and countersunk flush.
 5. Exposed bolt ends not permitted. Chrome plated hexagon type cap nuts to be provided on all exposed bolt ends.
- I. Rolled Edges
Rolls shall be as detailed with corners bullnosed, welded, ground and polished.
- J. Corners
Dishtables, drainboards, splashbacks and turned up edges shall have 1/2" (15 mm) or larger radius bends in all horizontal and vertical corners, coved at intersections unless specified otherwise.
- K. Enclosed Cabinet Bases
Bases shall be made of 18 gauge stainless steel sheets reinforced by forming the metal. Sides and partitions shall terminate at front in a 2" (50 mm) wide fully enclosed mullion and welded at intersections. Shelves are to be removable where detailed. Exposed ends, partitions and shelves are stainless steel.
FSEC to coordinate size, quantity and location of louvered openings for sufficient ventilation of food service equipment.
- L. Legs and Cross Rails
1. Equipment legs and cross rails shall be 1-5/8" (40 mm) 16 gauge stainless steel tubing unless otherwise noted. All welds at cross rails shall be continuous and ground smooth. Tack welds are not acceptable. Tops of legs to be fitted with Component Hardware Model # A20-0206 16 gauge stainless steel gusset or approved equal. Gussets are to be secured as hereinafter described to fixtures.
 - a. Sinks:
Weld gussets to triangular 12 ga. stainless steel gusset plates, which are in turn welded to underside of sinks.
 - b. Tables and Dishtables:
To metal top tables and dishtables with gussets which shall be welded to reinforcing channel/hat sections 14 gauge or heavier.
 - c. Wood tops:
Welded stainless steel hat sections to support top and be held in place with stainless steel metal screws in slotted holes of flanges.
 2. Bottom of legs to be fitted with Component Hardware Mode # A 10-0851 with locking ring adjustable stainless steel foot or approved equal. Foot plug to be welded, ground and polished. When flanged feet are specified, use Component Hardware Model # A-10-0854 adjustable stainless steel

foot or approved equal.

3. Enclosed cabinet bases mounted on 6" (150 mm) high legs are to be equipped with Component Hardware Model # A52-9907 adjustable stainless steel counter legs or approved equal.

M. Metal Gauge

Unless otherwise noted in itemized specification or details, all gauges to be manufactured to the following minimum thickness:

Stainless Steel USS Gauge	Decimal Thickness	Millimeter Thickness
12	.1094	2.78
14	.0781	1.98
16	.0625	1.59
18	.0500	1.27
20	.0375	0.95

N. Materials

All fabricated items to be provided in gauge, metal type and finish per the following table.

Description	Gauge	Metal	Finish No.
Dishtable, Table and Counter tops	14	S.S	4
Hat Sections/Channel:			
Unexposed	14	Galvanized	4
Exposed	14	S.S	4
Counter Body:			
Framework	14	Galvanized	
Aprons, Partitions, Backs and Ends	18	S.S	4
Shelves (Intermediate)	18	S.S	4
Shelves (Base Shelf)	16	S.S	4
Refrigerators Interiors	20	S.S	2B
Doors			
Outside Faces	18	S.S	4
Inside Faces	20	S.S	2B
Drawer Pans			
General	18	S.S	2B
Plastic Refrigerated	18	Uniroyal "Royalite" Series S.S	2B
Shelf			
Wall Mounted	16	S.S	4
Fixture Mounted	16	S.S	4
Table	16	S.S	4
Refrigerator		S.S Wire	

Shelf Bracket (Exposed)	14	S.S	4
Ventilators & Hoods			
Exterior Frame	14	S.S	4
Interior	18	S.S	4
Plenum	16	S.S	4
Ducts			
Unexposed	16	Galvanized	Weld
Exposed	16	S.S	4-Weld
Dishmachine	18	S.S	4-Weld
Wall Flashing	20	S.S	4
Equipment Legs & Cross Rails			
	16	S.S Tubing	4

- O. Closure
 Return backsplashes, when exposed to have enclosed finished rear.
 Exposed backs of all fixtures, back splashes, shelves, etc., shall be closed.
 Exposed backs of counter top equipment in an island configuration will be provided with a full height stainless steel enclosure to conceal utility connections.
 Where the rear of a piece of equipment placed in a wall opening is exposed and unfinished, the FSEC will provide a finished rear.
- P. Casters
 Casters shall be Colson Caster Corp. Series 2, or equal, non-marking, ball bearing NSF approved type with greaseproof polyurethane tires, Wheels shall be 5" (130 mm) diameter. Minimum width treads of 1-1/4" (30 mm). Minimum capacity per caster 250 lbs. (115kg). Where a set of four casters is specified, two are to be provided w/ brakes.
- Q. Sinks
 1. Fabricated sinks shall have corners same as for metal tops. One piece welded construction with bottom pitched to drains and double wall partitions (see standard detail C-8-5 & C-8-8). Multiple compartments shall have continuous and seamless flush front exteriors. Openings between compartments or applied panel will not be accepted.
 2. Sink insets shall be 14 gauge stainless steel welded as integral part of top.
- R. Drawers
 All drawer pans shall have all corners coved. Pan to be mounted on fabricated 14 gauge stainless steel angle cradle frame. Frame to be supported on Component Hardware Model S-52 or approved equal full extension slides with 200 lbs. (91 kg.) capacity per pair. Pan to be easily removable without the use of tools. Drawer fronts shall be double pan type with sound deadening material. Drawer shall be self-closing.
- S. Doors
 1. All metal doors to be double pan type reinforced and stiffened to prevent flexing and filled with sound deadening material.
 2. Sliding doors shall be mounted on large ball bearing quiet rollers in 14 gauge stainless steel overhead tracks and be removable without the use of tools. Sliding doors shall be self-closing.

3. Hinged doors shall be flush type, mounted on heavy duty, stainless steel, lift-off hinges.
 4. Door catches shall be heavy duty, 4 way (mortise or surface application) with adjustable spring loaded ball tension, Model M22-2430 as manufactured by Component Hardware Inc. or equal.
- T. Hardware
1. All hardware shall be of heavy duty construction and identified on shop drawings by manufacturer and model number and shall be subject to final approval by Designer.
 2. All hardware shall be identified with manufacturer's name and number so that broken or worn parts may be replaced.
- U. Breaker Strips
- All ice pans, ice bins, refrigerated pans, hot food, Bain Marie pans and cabinets shall be provided with breaker strips where adjoining top or cabinet face materials to prevent condensation. Breaker strips shall be fastened with stainless steel, counter sunk screws. Pop rivets will not be accepted.
- V. Insulation
- All insulation shall be board form or foamed-in-place polyurethane. Fiberglass insulation shall not be used. Heated areas shall have minimum of 1" thick at sides and 2" thick at bottom. Cold areas shall be thickness indicated on details or drawings. Insulation shall be bonded to all surfaces.
- W. Refrigerated Items
1. All reach-in refrigerators and freezers with remote refrigeration systems shall be complete with condensate evaporator when no floor drain is available.
 2. When a condensate evaporator is required, it shall be complete with thermostatic expansion valves at the evaporator.
 3. Fabricated compartments, refrigerated shelves, plates, etc., shall be provided with a 20 gauge steel box to house expansion valves when valve is remote from evaporator. Install in base of fixtures or in a concealed position.
 4. All refrigerated compartments shall be fitted with a flush mounted exterior dial thermometer with chrome-plated bezels. Thermometers shall be adjustable and shall be calibrated after installation.
 5. Refrigerator hardware for fabricated refrigerator compartments shall be heavy duty components. Hinges shall be self-closing. Latches to be magnetic edge mount type with cylinder lock, keyed alike to the extent possible, unless specified or noted.
 6. Refrigerated drawer units are to be provided with stainless steel drawer liners and stainless steel full size pans. Food Service Equipment Contractor to furnish each drawer with two (2) 12" x 20" x 4" deep 18 ga. stainless steel pans. Provide drawers with cylinder lock, keyed alike to the extent possible, unless specified or noted.
 7. When a removable plate rail/ cutting board is specified for an equipment stand, the Food Service Equipment Contractor is to coordinate cutting board support locations with work top cooking appliances to provide access for operations and service.
 8. The refrigerant for medium and low temperature fixtures to be CFC free and conform to the Montreal Protocol Agreement.
 9. All refrigeration systems to be provided with 5 year compressor warranty

and 1 year service agreement.

- X. Louvered Shelving
At location of three (3) compartment or pot wash sinks, wall shelving to be louvered to facilitate drainage and air drying. Construction of shelving to be the same as solid shelving as noted under 2.05M. See CFL standard detail C-1-2.
- Y. Flanged Feet Pinned to Floor
Free-standing work tables and counters with flanged feet shall be secured to the floor with smooth head stainless steel fasteners or with pins concealed in all legs of the table/counter when specified.
- AA. Backsplash "Returns"
Backsplashes on tables and counters are to be returned at the sides where adjacent wall, columns and other equipment to match the dimension of the adjacent element.
- AB. Wall Flashing
Wall flashing to include component hardware Model # J64-1450 divider bars and Model # J-63-1451 cap strips as required.
- AC. Protection of Tops/Shelves
In order to protect finishes of fabricated items, all exposed horizontal surfaces of counter, tables & shelves are to be covered with cardboard & held in place with duct tape until such time that the work of related trades is complete.
- AD. Adapter Bars
Provide adapter bars for "buy-out" equipment units where adapter bars are listed as an option/accessory by the manufacturer. Provide maximum number of adapter bars based on the smallest pan size to be used.
- AE. Remote Controls
Remote controls for equipment units built into custom fabricated assemblies shall be recess-mounted to protect the controls from damage. Surface mounted remote controls are not acceptable.

2.8 MILLWORK EQUIPMENT

Approved Millwork Contractors: The following is a list of Millwork Contractors that are approved as subcontractors on this project. The bidders must include pricing from one (1) of these contractors in their base bid. Pricing from an alternate millwork contractor of the Food Service Equipment Contractor's choice may be shown as a "deduct alternate" on the bid quotation form in the space provided.

American Foodservice	Savannah, TN	(800)-447-4693
Interior Creations Inc.	Philadelphia, PA	(215)-425-9390
Legere Woodworking Co.	Avon, CT	(860)-674-0392
RPI	Medford, NJ	(609)-714-2330

A. Workmanship and Fabrication:

The following general requirements shall govern the construction of millwork built fixtures, except where otherwise noted.

1. Work shall be performed by skilled craftsmen of the trade and shall be of the highest quality throughout, in such a manner as to fulfill the intent of the Contract Documents.
2. Fabrication, finishing, and installation of millwork specified in this section, shall be by one Contractor and shall not be sublet unless specifically approved by the Designer.
3. Woodwork to be 3/4" plywood throughout except at wet or moisture areas (such as sinks, beverage counters, water stations,) where 3/4" marine plywood is required.

4. Woodwork counters shall be constructed to support the full weight of operating appliances without any deflection of the counter top. Where cut-outs are required in counter tops, appropriate framing needs to be provided around the cut-out to fully support the top in level position.
 5. All miter joints shall be tight with no gaps or open spaces. Filling of miter joints with crack filler prior to finishing is not acceptable. Loose joints shall be hairline, flat, in single plane, with no exposed screws, nails or other fasteners. All dimensions, reveals and joints shall be held exact.
 6. All fixtures shall be assembled in single and complete units as the dimensions will permit shipment to and installation at the building. Large pieces requiring sectional construction shall have their parts accurately fitted and aligned with each other, and provided with ample screws, glue and bolt blocks, tongues, grooves and splines, dowels, mortises and tenons, screws, bolts or suitable means of concealed fastening, as required to render the work substantial, rigid and permanently secured in proper position.
 7. Sufficient additional material shall be allowed to permit accurate scribing to walls, floors and related work, and due allowance made wherever possible for such shrinkage as may develop after installation. Single and sectional units shall be provided with adequate cleating, blocking, crating and other forms of protection as required to prevent damage, soiling and deterioration during transit, delivery, storage and handling.
 8. Framing and blocking members shall be assembled with bolted and screwed connections and should be secured to the structural backing with cinch, expansion screws or toggle bolts, as required; spaced and installed to insure ample strength and rigidity. Rails and stiles shall be mortised and tenoned, work neatly mitered and membered, all butt joints made flush and smooth, and all permanent joints made up with water resistant glue. All fixtures shall be assembled without face screws or nails, except where it may be necessary to attach trim items. All face screws or nails which are necessary shall be countersunk and plastic wood or wood plugs used to cover head, and the plug neatly touched up. The heads of all screws used in any assembly shall be countersunk below the surface.
- B. Joints
1. Mortise and tenon, spline, dowel and/or pin block and glue work to avoid use of nails wherever practical. Make butt joints with an approved device for prevention of separation of members. Blind nail and conceal.
- C. Plastic Laminate (HDPL)
1. Plastic laminate shall be bonded to all exposed surfaces with contact cement fast bond #30, as manufactured by 3-M Products Company, or equal, to minimum 3/4" fir faced plywood applied under high pressure. Reject plastic laminate or plastic backing shall be used to prevent warping, unless otherwise specified. All edges shall be carefully sanded to smooth finish, removing burns, nicks and cut marks.
 2. Plastic laminate joints shall be finished without wavy and unsightly joints. Joints need not be mitered except if specified. Hand sand edges to a slight chamfer.
 3. Plastic Laminate products to be High Pressure Decorative Laminate as specified under AWI Standards.
 4. Foodservice Equipment Contractor to confirm installation requirements with

food service equipment manufacturer where equipment units penetrate the counter top. Foodservice Equipment Contractor to coordinate installation requirements suggested by the manufacturer with the Millwork Contractor.

- D. Doors, Hinged
 - 1. Hinged doors shall be fabricated of 3/4" thick plywood with plywood full perimeter edging with plastic laminate on face and self-edging on exposed sides. Door hinges, pulls and catches shall be supplied and installed as detailed and to be as manufactured by HAFELE or equal.
- E. Doors, Sliding
 - 1. Sliding doors shall be fabricated of solid core plywood with hardwood edges and constructed similar to hinged doors. Doors shall be mounted on E-Z Glides track. Doors shall be removable without the use of tools. Rubber stops shall be provided concealed in end stile or mullion.
- F. Doors, Tambour Sliding
 - 1. Tambour sliding doors shall be fabricated of individual hardwood slats, 3/8" by 3/4" round on 2 edges and glued to 20 ounce duck canvas or reject elastic vinyl plastic or equal and shall be provided with hardwood end stile with integral door pull. Track shall be lined with laminated plastic or equally smooth surface and guides at top and bottom shall be fabricated hardwood. Provide lock-pin for sliding doors.
- G. Access Panels/Louver Panels/Louver Doors
 - 1. Access Panels: Shall be fabricated of 3/4" thick plywood and shall be fabricated to be removable for access. Each access panel shall be provided with 2 (two) magnetic catches at top and 2 (two) 3/16" positioning pins at bottom (unless otherwise specified or detailed on drawings).
 - 2. Louvered Panels: Are required in woodwork at all locations where proper ventilation is necessary for the efficient performance and operation (exhaust and/or supply) of the food service equipment compressor.
Types: (When specified)
 - a) Louvered panel constructed same as Access Panel except provided with louvers, spaced to conceal equipment yet provide adequate ventilation. Provide black color screening on rear with protective edges to prevent tearing.
 - b) Louvered panel to be extruded aluminum, Model ADL-5TC-4 W/RSM 4 Frame, spray painted to match plastic laminate of woodwork, as manufactured by Reliable Inc., Geneva, AL (205) 684-3621 or equal.
 - c) FSEC to coordinate size, quantity and location of louvered opening for sufficient ventilation of food service equipment.
 - 3. Louvered Doors:
 - a) Must have concealed hardware to resemble access panels. Doors to have nylon roller friction type heavy duty catch and heavy duty concealed stainless steel adjustable hinge.
 - b) Plastic laminate fronts. Provide kiln dried pine shutter type slats. Wood to be free of knots with smooth grain, epoxy painted to match laminate selection. No raw wood surfaces will be acceptable. Paint or laminate as needed between slats.
 - c) Slats to be fixed, positioned to conceal equipment from sight.
 - d) Provide black color screening/mesh on rear of door with protective edges to prevent tearing.

- e) FSEC to coordinate size, quantity and location of louvered opening for sufficient ventilation of food service equipment
- H. Drawers
 - 1. Drawers shall have dovetail construction, well glued and blocked. Fronts shall be not less than 3/4" thick plywood. Sides and back shall be 1/2" thick fabricated of Birch, Maple, or Sycamore except where extension slides are used, in which case the sides shall be 5/8" thick. Bottom shall be milled into fronts and sides. Drawers shall be provided with suitable stops. Provide pulls as detailed or specified and to be as manufactured by HAFELE or equal.
 - 2. The inside surfaces of all drawers shall receive one coat of Penetrating Primer and one coat of glass lacquer.
- I. Painted Finishes
 - 1. Painted finishes shall have exposed surfaces free from defects and blemishes that would show after being finished, regardless of grade specified. All surfaces specified to receive a paint or enamel finish shall receive one crosscoat of lacquer type undercoat. The undercoat shall be of appreciably different color from that of the finish coat, and of proper ground color with relation to the finish coat. After the undercoat has been thoroughly dried, surfaces shall be sanded smooth and two coats of enamel shall be applied. Back painting shall be provided for all cabinet and woodwork prior to installation.
- J. Interior & Wall Shelves
 - 1. Cabinet interiors and wall shelves shall be laminated as specified under Section 3 Plastic Laminate.
- K. Corian Tops
 - 1. Surfaces shall be Corian (methyl methacrylate binder) as manufactured by E.I. DuPont Nemours & Co., Inc. Wilmington, DE, or approved equal.
 - 2. Color and pattern shall be selected by the Designer, and physical properties shall conform to manufacturer's standard specifications. The material shall be homogenous; not coated laminate, or of composite construction.
 - 3. Corian sheet shall be 1/2" for counter tops, and backsplashes unless otherwise specified.
 - 4. General installation to conform with manufacturer's standard details in order to maintain product warranty, i.e. cut outs for drop in equipment.
 - 5. Foodservice Equipment Contractor to confirm installation requirements with food service equipment manufacturer where equipment units penetrate the counter top. Foodservice Equipment Contractor to coordinate installation requirements suggested by the manufacturer with the Millwork Contractor.
- L. Measurements
 - 1. Before proceeding with fabrication of woodwork required to be fitted to other construction, obtain field measurements and certify dimensions and Shop Drawing details as required for accurate fit.
- M. Pre-Cut Openings/Templates
 - 1. Contractor to obtain templates and or accurate dimensions for sizing of cutouts required in millwork from Food Service Equipment Contractor so that cutouts can be completed in shop.

- N. Wood Base Construction At Floor Drain
 1. Fabricate notch in base for floor drain locations as required in employee areas (field dimensioning required).
 2. In public areas, provide boxed out opening within base cabinet for floor drain locations (field dimensioning required). Provide stainless steel liner in box with top flange sealed in place.
- O. Submittal
 1. Shop Drawings:
 - a) Submit Shop Drawings showing location of each item, dimensioned plans and elevations, large scale details, attachment devices and other components including hardware schedule(s).
 - b) All the required cut-outs for food service equipment to be properly sized and located on Millwork Shop Drawings. Contractor to confirm locations of cut-outs with the Food Service Equipment Contractor prior to submitting Millwork Shop Drawings for approval.
 - c) The Contractor shall not be relieved of responsibility for any deviation from the requirements of the Contract Documents unless the Contractor has received written approval for the deviation.
 - d) Coordinate submittal requirement with FSE contractor. See 1.11 Submittals of Specific Conditions, K. Coordination Drawings.
- P. Product, Delivery, Storage and Handling
 1. Protect woodwork during transit, delivery, storage and handling to prevent damage, soiling and deterioration.
- Q. Job Conditions
 1. Examine site conditions affecting this Work. Report unsatisfactory conditions to the General Contractor and do not proceed until those conditions have been corrected. Commencing work implies acceptance of conditions existing at the site as satisfactory to the outcome of this Work.
 2. The responsible division shall advise the General Contractor of temperature and humidity requirements for woodwork installation areas.
 3. Fire Retarding:
 - a) Where required by code, all required materials are to be treated with fire retardant chemicals to achieve the required flame spreading performance rating. Retardant chemicals must be a type approved by local authorities.
 - b) Provide all fire retardant treated blocking as required for installation of Woodwork.
- R. Execution
 1. Inspection:

The responsible division must examine the substrates and conditions under which the work is to be installed and notify the Designer in writing of unsatisfactory conditions. Do not proceed with work until unsatisfactory conditions have been corrected in a manner acceptable to The responsible division.
 2. Preparation:

Prior to installation of woodwork, examine shop fabricated work for completion and complete work as required including back priming and removal of packing.

3. Installation:
 - a) Install the work plumb, level, true and straight with no distortions.
 - b) Shim, as required, using concealed shim and/or levelers. Install to a tolerance of 1/8" in 8'-0" for plumb and level, and with 1/32" maximum offset in flush adjoining surfaces, 1/8" maximum offsets in revealed adjoining surfaces.
 - c) Scribe and cut work to fit adjoining work and refinish cut surfaces or repair damaged finish at cuts. Scribe base as required to hard floors, such as wood and marble.
4. Wood Base/Standing and Running Trim:

Install with minimum number of joints possible, using full-length pieces (from maximum length of lumber available) to the greatest extent possible. No joints in verticals (standing). Stagger joints in adjacent and related members. Blind fasten all joints. No exposed fasteners shall be accepted.
- S. Adjustment, Cleaning, Finishing and Protection:
 1. Repair damaged and defective woodwork wherever possible to eliminate defects functionally and visually; where not possible to repair properly, replace woodwork. Adjust joinery for uniform appearance.
 2. Clean woodwork on exposed and semi-exposed surfaces. Touch-up shop-applied finishes to restore damaged or soiled areas.
 3. Contractor shall provide protection and maintain protection necessary to ensure that the work will be without damage or deterioration at the time of acceptance.

2.9 STANDARD DETAILS

CFL Standard Details (referred to as detail C-8-5, for example) included as part of specifications are to be considered guides to quality and scope of work involved. Where shop practices dictate, alternate construction methods and component items of equal manufacturer may be substituted. It will be the responsibility of the Food Service Equipment Contractor to prove the quality of the proposed methods.

2.10 COLD STORAGE ROOMS

- A. All prefabricated cold storage rooms shall be manufactured by one manufacturer and installed by factory supervised installer.
- B. Interior finished ceiling height shall be 8'-0" unless otherwise specified.
- C. Materials
 1. Insulation shall be non-burning urethane, foamed in place, not frothed or rigid board-foam.
 - a) Insulation shall be CFC free 4" thick foamed -in-place.
 - b) Insulation shall have a thermal conductivity (K-factor) not to exceed (0.14 B.T.U./hour/square foot) as tested on ASTM C-177, at 75° F. (24° C.) mean temperature and an overall coefficient of heat transfer factor (U) not to exceed 0.029.
 - c) Insulation shall be rated as self extinguishing and fire retardant type. Flammability characteristics per ASTM E-84 shall be less than 25 flame spread and less than 450 smoke density, in accordance with U.B.C. Section 1717.
 - d) Classification; Class 1 Uniform Building Code, U.B.C. Part VIII, Section 4201-4203. Class A National Fire Protection Association N.F.P.A. Number 101, "Life Safety Code", FM, UL, NSF Standard #7

- and approved for use in New York City.
2. Aluminum sheets used as a facia for wall and ceiling panels shall be stucco aluminum not less than 0.040" thick.
 3. Stainless steel sheets used as a facia for wall and ceiling panels shall be 20 gauge. Other stainless steel shall be the gauge specified. All stainless steel shall be 18-8, type 304, #3 finish unless otherwise specified.
 4. Galvanized steel sheets and/or galvalume used as a facia for wall and ceiling panels shall be prime finish, not less than 20 gauge complying with ASTM 525 and with G90 coating.
 5. When specified, wall protection panels shall be Fiberglass Reinforced Polyester (FRP-X) Paneling 3/32" thick, embossed, white color or as specified with low smoke and less than 25 flame spread rating.
- D. Panel Construction
1. Panels shall consist of precision die formed metal pans with 1/2" to 3/4" flanged perimeter, foamed in place urethane insulation between interior and exterior pans, thoroughly checked for gauge and accuracy. Panels shall be of same size wherever possible and shall be interchangeable with panels of like size. Metal pans shall be treated on the inside with a preparation coating of bonding agent to ensure a stable adhesion with the chemical bonding capabilities of the insulation.
 2. Wall and ceiling panels shall be 4" thick and contain 100% foamed in place insulation and shall not have any internal wood or metal structural members. To ensure tight fitting joints, all panel edges shall have foamed in place urethane tongues and grooves and a flexible vinyl gasket foamed in place on the interior and exterior of all edges.
 3. Panels shall be rigidly coupled by a cam action hooked locking device. Locking device shall be foamed in place, maximum 48" on center. Locking device shall be accessible from the inside to facilitate installation in confined areas and shall be provided with press-fit caps to close wrench holes. Joints between panels shall be sealed at interior and exterior edges with a PVC gasket or an odorless nontoxic, synthetic polymerized sealant, to maintain continuity.
 - a) Wall panels shall have a minimum of three (3) locking devices between each panel, located in the center, lower corner and upper corner.
 - b) Ceiling panels shall have a minimum of two (2) locking devices between ceiling panel and at wall panels, located at each corner of the wall panel. Ceiling panel joints shall be offset from wall panel joints.
 - c) Pre-fabricated floor panels shall have a minimum of two (2) locking devices between each floor panel and at wall panels, located at each corner of the wall panel.
 4. All interior vertical corners shall be coved with a 1/2" radius.
 5. Exterior panels, interior partitions, corner panels, ceiling panels and "T" intersection panels shall be matching construction.
- E. Wall/Ceiling Support System
1. Ceiling panels shall have a maximum deflection of 1/240 of the span under uniform loading of twenty (20) pounds per square foot. When the ceiling panels require a support system, the Manufacturer shall submit details and structural calculations to an engineer for approval prior to fabrication. A

- copy of the approved submittal shall be forwarded to Owner and Designer.
2. An indoor ceiling panel support system, when required, shall be furnished and installed using a self-supported system or with a hanger wire network attached to hanger brackets, designed to engage with the female lock pins imbedded within the roof panel foam core, spaced 4'-0" on center, per the item specification.
- F. Floor Types and Conditions
1. TYPE I - Insulated depressed building floor with quarry tile finish to be as follows:
 - a) The floor shall be constructed at the job site in a depressed slab.
 - b) Cold storage room flat bottom wall panels shall extend down into the bottom of the depression. G.C. to provide two (2) 2" thick layers (or as specified) of rigid board foam urethane with staggered joints in depression over vapor barrier, installed after walls are in place. In freezers use Class I for floor insulation of not less than R-8/inch at 20°F.
 - c) On top of floor insulation G.C. to provide a protective covering of 15 pounds felt. Over lap joints 6". Flash up sides to height of wall base.
 - d) When indicated on contract documents, finished floor outside the cold storage rooms shall ramp up 1" to the floor inside by the G.C. The finished floor between cold storage rooms shall be ramped as well when indicated.
 - e) Provide coved base quarry tile (by General Contractor) at interior perimeter and at exposed exterior panel walls.
 2. TYPE II - Pre-fabricated Floor Types to be as follows (per itemized specifications):
 - a) The 4" floor shall be pre-fabricated NSF-approved metal-clad, foamed-in-place urethane insulated panels. Floor panel construction and insulation to match that of wall and ceiling panels. Floor panels shall be fully coved with a minimum of 3/8" radius. The exposed wearing surface will be metal-clad with a finish as indicated in the itemized specifications. Exterior bottom face of floor shall be clad with galvanized steel or galvalume.
 - b) When indicated in itemized specifications, the 4" floor panels are to be heavy-duty with factory structural support that transfers the weight-bearing capacity to the building sub-floor via internally foamed-in-place supports on approximate 12" centers.
 - c) The 2" floor shall be pre-fabricated NSF-approved metal-clad, foamed-in-place urethane insulated panels. Floor panel construction and insulation to match that of wall and ceiling panels. Floor panels shall be fully coved with a minimum of 3/8" radius. The exposed wearing surface will be metal-clad with a finish as indicated in the itemized specifications. Exterior bottom face of floor shall be clad with galvanized steel or galvalume.
NOTE: Heavy-duty structural floor option is not available on 2" floors.
 - d) When indicated in itemized specifications, the wearing surface is to be finished with Altro Atlas 40, First Choice or Protect-All (Oscoda Plastics) seamless flooring with a 6" coved base at interior perimeter of floor.

- e) The factory provided floor is to be 5/8" foamed-in-place marine-grade plywood. The standard factory metal skin is to be eliminated so that the seamless floor can adhere directly to this plywood surface.
 - f) Interior/exterior ramps with non-slip treads shall be furnished where specified and/or indicated on drawings.
 - g) Provide coved base quarry tile at exposed exterior panel walls.
- G. Door and Door Frames
- 1. Door sizes shall be 36" wide x 84" high or as specified, hinged as indicated on plan. Door shall be able to remain open when opened over 120°.
 - 2. Door shall be infitting, flush mounted, double panned 20 gauge stainless steel interior and exterior panels or as specified with foamed-in-place urethane insulation, 4" thick minimum. Same construction as for wall panels. Corners of doors shall be Heliarc welded, ground and polished.
 - 3. Furnish and install a removable threshold at each low temperature door, constructed of 16 gauge stainless steel.
 - 4. Provide a heating element on the ambient side of each freezer/ food bank door frame head, jambs and threshold. The heating element shall be a dual 120 volt, 240 watt with thermostatic control, factory prewired to a "GS" splice box located above the door on the roof exterior. Division 26 - Electrical shall make final connection.
 - 5. Gasket shall be extruded polyvinyl chloride with vulcanized corners and continuous magnetic core at sides and top of door frame. The stainless steel jamb facing shall extend to protect the gasket.
 - 6. Door shall be adjusted to be self-closing after installation and floor is finished.
 - 7. Sill wipers for Type I floors shall be adjustable, extruded neoprene secured by removable stainless steel retainer strip and fasteners.
 - 8. Each hinged door shall have:
 - a) Kick plate of 1/8" diamond plate 3'-0" high and full width of door. Mount on the interior and exterior face of each door and door section.
 - b) Hinges, three (3) each per door, shall be Kason 1253 Series, or approved equal, cam lift, zinc die cast and polished chrome plated
 - c) Latch shall be Kason 1239 Series, or approved equal, heavy duty chrome plated brass with adjustable keeper, interior safety release and provisions for padlocking. Padlock by others.
 - d) Door closer shall be Kason Model 1095 or approved equal.
 - e) Hardware shall be mounted with 12 gauge reinforced steel tapping plates and machine screws.
 - f) Heated viewport approximately 14" square (or as specified), minimum triple thermopane glass. Viewport wiring to be concealed within door and out top of door, complete with flex cable to recessed splice box within door section.
 - g) 2-1/2" dial thermometer flush mounted, to monitor the interior temperature of cold storage room, surface mounted on door panel. When specified, provide door panel with flush mounted 4-1/2" diameter dial thermometer in lieu of factory standard.
 - h) Schlage, or equal, mortise lock with recessed thumb turn on exterior door only.

9. Door section shall be self supporting constructed similar to wall panels with 4" foamed in place urethane core. No wood framing will be permitted.
 10. Each sliding door opening shall have a secondary door similar to Eliason FCD-120 or equal. Door(s) to be clear PVC with top mounted gravity operated hinge sized to suit the opening per the manufacturer's recommendations.
- H. Light Fixtures and Switches
1. Quantity of light fixtures shall be as indicated on the electrical plan.
 2. Light fixtures;
 - a) Incandescent: Kason # 1801, light fixture with # 1804 plastic coated globe with wire guard and sized to receive one 100 watt bulb unless otherwise specified.
 - b) Fluorescent: Shall be Lithonia Commercial Model DMW 240 120 CW 48" double fluorescent light fixtures with low temp ballast designed to operate at the temperature of the Cold Storage Room(s).
 3. Cold storage rooms with doors at each end shall have three way switches on the exterior.
 4. Light switches shall be three way or four way, AC, pre-switch, mounted in recessed "FS" boxes with grey Hypolan, weatherproof plate and unbreakable red plastic pilot light lens constant burning on interior and indicating on exterior.
 4. Light switches shall be factory mounted on the latch side of doors and prewired with rigid conduit and wiring run within the wall panel, terminated in a vapor tight splice box mounted on the interior wall near ceiling. Manufacturer shall provide a 1-1/4" diameter hole in ceiling panel with a loose escutcheon through which Division 26 - Electrical shall make final connections.
 6. F.S.E. Contractor shall furnish the required number of incandescent /fluorescent bulbs/tubes for each light fixture.
- I. Audio-Visual Temperature Alarm
1. When specified, an audio visual temperature alarm shall be furnished for each cold storage room.
Unless specified otherwise, unit shall be Modularm Corporation (or equal) flush mounted with stainless steel cover plate, mounted on the exterior door section of each cold storage room, pre-wired with rigid conduit and wiring run within the wall panel using "FS" recessed box on the exterior and terminated in a "GS" splice box mounted on the interior near the ceiling. Manufacturer shall provide a 1-1/4" diameter hole in ceiling panel with loose escutcheon through which Division 26 - Electrical shall make final connection. Where there are multiple compartment cold storage rooms, alarms will be ganged into a common alarm panel.
 2. Temperature alarm system shall consist of solid state audio alarm, silence button, trouble light, digital read out, indicator/failure lights, controller, time clock and stainless steel cover and battery back-up.
 3. Control panel for the temperature alarm system to be located where shown on plans. F.S.E. Contractor to coordinate with appropriate trades for installation of panel.
 4. Provide contacts for eventual connection to building alarm system.
 5. When the door does not open into an ambient area, the temperature alarm

system be factory installed, as specified above, in a remote wall panel with an ambient face that will not interfere with other equipment and functions and identified with a name plate of the room being monitored. The sensor capillary shall be extruded as required and, when necessary, run in electrical conduit. Provide escutcheon plates on each side of each partition penetrated.

J. Food Banks

1. When specified, furnish Food Banks with a Honeywell Model DR-4300-12 chart recorder or equal. Chart recorder to be 7-day record, single pen unit with probe.
2. Chart recorder to be located where shown on plans. F.S.E. Contractor to coordinate with appropriate trades for installation of panel.
3. Conduit, control wiring and interconnection between probe (at blower coil location) and chart recorder to be by Division 26 - Electrical.

K. Door Fan Switch

1. When specified, a door fan switch shall be provided for each low-temperature cold storage room, when it opens into a non-refrigerated area, to shut off evaporator coil fan motors when the door is opened.
2. Door fan switch shall be factory mounted on the door jamb and prewired with rigid conduit and wiring within the wall panel to a splice box located on the interior near the ceiling. Manufacturer shall provide a 1-1/4" hole in ceiling panel with a loose escutcheon through which Division 26 - Electrical shall make interconnection to the evaporator coil(s) fan motors.

L. Closure Panels

1. Closure panels shall be furnished and installed to close the space between the exterior top of the cold storage room and the finished ceiling of the building.
2. Panels to match exterior panel finish. Panels to be lift out type with side turned in to form a pan. At ceilings, securely fasten a channel and at face of cold storage room, securely fasten an angle for panel to slip into. Channel and angle to match panel material.
3. When exterior finish is FRP-X, the closure panel shall be white stucco aluminum.
4. When the area does not have a finished ceiling, closure panels shall not be required, unless otherwise specified or required by the health department.

M. Trim

1. Vertical trim strips and angles to match cold storage room exterior finish. Trim to be applied with a minimum of exposed fasteners to fully seal cold storage room adjacent walls, etc.
2. The FRP-X paneling with a "J" end cap molding is to be extended past the end of the cold storage room wall to the building wall and caulked with silicone as required.

N. Ramps and Sills

Ramps and sills when required shall be prefabricated 16 gauge stainless steel ramps with 14 gauge galvanized reinforcing and urethane foamed in place insulation. Wearing surface to have Altro Atlas 40 or ProtectALL (Oscoda Plastics). See specifications and drawings for size and shape. All door sections shall be provided with minimum 14 gauge stainless steel sill plate complete with heater cable as stated under door section. Sill to be either built into ramp/pre-fabricated floors or to be part of door section on insulated depressed building floors. Sills to

be removable for replacement of heater cable.

- O. Utility Penetrations
 - 1. Provide openings in ceiling and wall panels to accommodate all electrical, refrigeration and drain lines.
 - 2. Seal all openings with silicone after lines have been run and before installation of escutcheons.
- P. Escutcheons
 - 1. Provide sufficient quantity of 5" diameter blank stainless steel escutcheons to trim all interior and exposed exterior penetrations.
 - 2. Provide cutting of proper size hole in blanks and panel penetrations.
- Q. Pressure Relief Vent
 - 1. Pressure relief vent shall be factory installed at each low-temperature cold storage room door.
 - 2. Pressure relief vent shall be electrically heated, 120 volt and have aluminum screen.
- R. Corner Guards
 - 1. Provide corner guards on the exterior outside corners. The corner guards shall be 4"x4"x48" 16 gauge stainless steel secured to wall panels with a full bed of contact adhesive. When FRP-X finish is specified, corner molding shall be omitted behind the corner guard.
 - 2. Corner guards on the interior outside corners shall be 2" x 2" by height of wainscot or 48" high 16 gauge stainless steel secured to wall panels with a full bed of contact adhesive. When FRP-X is specified, outside corner molding shall be omitted behind corner guards.
 - 3. Provide full height corner guards on exposed corners of interior door casings.
- S. Divider with Gate
 - Divider and gate, when specified, shall be aluminum expand-x where indicated on drawings.
 - 1. Panel mesh shall be flattened aluminum expand-x heliarc welded to aluminum frame.
 - 2. Frame shall be 1-1/2" by 1-1/2" by 1/8" aluminum 6061-T6 angle. Frame shall have 3" space at bottom and 6" space at top.
 - 3. Horizontal stiffeners shall be 1-1/2" x 1-1/2" x 1-1/8" aluminum angle.
 - 4. Floor plates shall be 3" by 3" x 1/4" aluminum heliarc welded to angle posts.
 - 5. Gate shall be of same construction as divider, 2'-10" wide with lock similar to that specified for insulated doors.
- T. Rub Rails - Interior/ Exterior
 - When specified, rub rails shall be located where indicated on plans.
 - 1. Rub rails shall be continuous lengths of 18 gauge stainless steel "U" shaped hat section secured to wall with stainless steel sheet metal screws 18" O.C. Exposed ends shall be bevel cut, capped, welded, ground and polished.
- U. Strip Curtain
 - Strip curtain when specified, shall be Model M-200 manufactured by Curtron Industries Inc. with closed brackets, or approved equal.

- V. Door Locking Bars
 - 1. Door locking bars, when specified, shall be 1/8" by 2" stainless steel two piece, hinged and secured at each end with interior safety release. Bar shall swivel and where the ends meet in the center shall have a 2" long 90° "L" drilled to receive padlock, padlock by others.
 - 2. When a door locking bar is specified, the latch specified in paragraph G.10.C shall be replaced with a Kason Model 577 polished chrome plated door pull, or approved equal.
- W. Identification Signs
 - 1. At exterior of each Cold Storage Room provide and permanently affix engraved plastic name plates with maximum 3/4" high letters and number identifying each Cold Storage Room and Refrigeration System to match "as built" diagram. Name plate to be mounted with adhesive below respective digital thermometer alarm. A similar name plate with 1/2" high letters is to be installed in a like manner on the evaporator coil(s) at all other items having a remote Refrigeration System.

2.11 REMOTE REFRIGERATION SYSTEMS

- A. All remote refrigeration systems shall be furnished and installed by one contractor, unless otherwise specified. Provide all components necessary for a complete and operable system. System to be fully capable of satisfying the refrigeration requirements for each fixture as defined by the manufacturer of each fixture.
- B. It is the responsibility of Division 11400 to follow all applicable codes and current refrigeration industry standards and practices when determining line sizes and installing and starting up remote refrigeration equipment.
- C. Compressor and Condensing Units
 - 1. Units shall be factory assemblies complete with hermetic units below 1 HP, semi-hermetic units 1 HP and larger, air or water cooled condenser, depending upon building conditions and specifications, high-low pressure controls, suction accumulator on low temperature system, sight glass, liquid line dryer, suction and discharge service valves, liquid receiver, and electric control panel. The electrical control panel shall be furnished with magnetic motor starter, defrost timer clock, and contractors in accordance with "Refrigeration Schedule". Compressor capacities shall be based on Air Conditioning and Refrigeration Institute (A.R.I) Standards. The refrigerant for medium and low temperature fixtures to be CFC free and conform to the Montreal Protocol Agreement.
 - 2. Capacities shall be based on the following:
 - a) Compartment temperature and evaporating temperature greater than 32°F (0°C) 18 to 20 hours operations.
 - b) Compartment temperature greater than 32°F (0°C) and evaporating temperature less than 32°F (0°C) 16 hours operation.
 - c) Compartment temperature and evaporating temperature less than 32°F (0°C) 18 hours operation.
 - 3. Condensing units shall be mounted on a steel base to effect a quiet operation. All rotating parts to be carefully balanced for minimum vibration and lubricated with forced or splash oil system. Receiver shall be sized for a complete pump down of the system and shall be shell type with fusible plug.
 - 4. Compressor units to be provided with suction and discharge back setting

- type service valves and standard machinery finish.
5. Motors shall be single speed, maximum 1750 R.P.M. compound wound ball bearings or sleeve bearing. Double squirrel cage motors with high starting torque set and low starting current to be used in a 3 phase application.
 6. All machines to be equipped with quick acting type high-low pressure control switches having adjustable range and differential and high pressure cut-out. Cut-out to be automatic reset type.
 7. For air-cooled units the condenser shall be a standard manufactured part of the equipment. Condensing temperatures shall be based upon (100°F 38°C) ambient air.
 8. Other components and accessories, such as suction filter and crank case heater shall be furnished when specified in the itemized specifications.
- D. Motor Starters-Contactors
1. All single phase motors shall be provided with mounted and internally wired contactors, except where pre-wired units are furnished without contactors. Single phase compressors shall be provided with built-in thermal and electrical overload protection.
 2. All three phase motors shall be provided with magnetic type starters with quick trip overload elements matched for motor amperage except where overload protection is built into the compressor motor and the manufacturer supplies a contactor instead of a starter. Overload heater element shall be sized according to manufacturer's recommendations. Compressor motor starters shall be definite purpose starters with manual reset.
 3. Starters shall be installed upon surfaces free from excessive vibrations.
 4. Where starters are required for installation in a motor control center, make and model of control center shall be verified and starters provided to match.
- E. Oil Separator
1. Provide oil separators, except when Compressor Manufacturer requires otherwise, 34°F, (1°C) and below and install as near as possible to the compressor. The return line shall be connected to the top of the crank-case above the oil level. Where compressor does not have connection for oil return line from separator, connect to a tee in the suction line adjacent to the compressor. Exposed oil return line to be provided with shut-off valve of the packless stem type.
- F. Compressor Racks
1. Racks shall be of the number of tiers and quantity to accommodate the number of condensing units specified for each rack assembly and allow for service clearance and ventilation. Review and confirm access into building or housing requirements to roof top locations.
 2. Racks shall be fabricated with structural steel of size and quantity to properly support the equipment to be installed on the rack. In special applications where building access is limited, construct rack framing with Dexion of Unistrut material.
 3. Racks shall be all welded construction with welds ground smooth.
 4. After completion of fabrication the complete rack shall be cleaned, primed and painted with top quality oil base enamel.
 5. Each rack shall be equipped with a pre-wired duplex outlet.
 6. Racks shall be pre-wired to a circuit breaker panel and pre-plumbed to a header (when specified water cooled) requiring a single point electrical and plumbing connection.

7. Racks shall have UL or equivalent approval.
 8. Special Conditions: For custom built racks for individual condensing units provide Dxion Angle Iron.
- G. Coils and Cooling Units
1. Units shall be direct expansion type of size and design to effect required temperature, humidity and to suit application intent.
 2. Units shall be hung from the ceiling with 1/2" nylon rods with plated steel nuts and washers. Rods shall extend through ceiling to bracing adequate for the suspended weight. Bracing shall be furnished as required, penetrations shall be sealed and trimmed with escutcheon plates.
 3. Units shall be installed tight to ceiling. All installations adjacent to walls shall be set out a minimum distance conforming to manufacturer's directions, to ensure proper air circulation and performance.
 4. Units with fan or blower and motor shall have thermal overload protection and be wired as indicated in "Refrigeration Schedule".
 5. Defrost cycle shall be based on the following:
 - a) Coils for 32°F (0°C) and lower shall have an electric defrost controlled by a time clock mounted on the compressor rack or at evaporators locations inter-wired by Division 26 - Electrical.
 - b) Coils for 33° (0.6°C) and 34°F (1°C) shall have an air defrost controlled by a time clock mounted on the compressor rack or at evaporators locations inter-wired by Division 26 - Electrical.
 - c) Coils for temperature above 34°F (1°C) shall have an air defrost in the off cycle controlled by proper sizing of the coil and the compressor.
 6. Location of coils shall be coordinated with shelving and floor sink locations.
 7. All coils for fabricated refrigerators and/or freezers shall be installed for accessibility and replacement.
- H. Penetration Sleeves and Plates
1. Service line penetrations of insulation to accommodate electrical conduit, refrigerant and drain lines, shall be limited to a minimum with service stubbed through insulation or locations predetermined by respective divisions.
 2. Where service lines penetrate insulated walls, the opening shall be packed with caulking, before trimming with escutcheon plate.
 3. Where service lines penetrate building walls outside of foodservice areas, the opening shall be packed with "Perma-Gum" and foam caulking.
 4. All exposed ends of sleeves, both inside and outside of compartments, are to be trimmed with 24 gauge stainless steel escutcheon plates, furnished as blanks in which respective work divisions shall cut required line holes and install.
- I. Refrigerant Piping
1. Copper tubing for refrigerant piping shall conform to ASTM standard specifications, serial designation B-88. All piping shall be type "L" ACR hard copper or cleaned and sealed soft type "L" tubing, dry seal or equal as indicated. Forged or wrought copper fitting with sweat or soldered joints shall be used.
 2. Tubing shall be cut only with a tube cutter and sized with a sizing tool.
 3. Piping shall be exposed to view as required by the standard safety code for mechanical refrigeration.

4. The liquid suction lines from condensing units to coil shall be sized and run as shown on the "Refrigeration Schedule" and Refrigeration Drawings.
 5. Piping run within cold storage rooms shall be finished with aluminum paint.
 6. For exposed areas, accessible furred ceiling spaces and in walls or excavated trench type installations, hard copper tubing shall be used. Exposed tubing shall be run in a manner to preclude damage by activities in the area; or shall be protected by conduit, furnished and installed as part of this contract. Conduit shall have water evacuated and both ends completely sealed.
 7. For piping run in conduit through inaccessible areas, such as under slab on grade, continuous one piece soft copper tubing shall be used with no joints. In lieu of large piping in conduit, especially vertical runs, random lines may be used; carefully fabricated and assembled to ensure equal pressure drop. Conduit required through inaccessible areas is provided and installed by the Electrical Division. Conduit shall have water evacuated, both ends completely sealed and be watertight.
 8. Ends of lines shall be capped to prevent contamination and opened only at time of final connection.
 9. Suction lines shall be sized for a maximum pressure drop from evaporator to compressor 2 lbs. (0.9 kg.) for high and medium temperature systems, and of 1 lb. (0.45 kg.) for low temperature systems and shall allow gas velocities of not less than 750 FPM (3.8 M/sec.) in horizontal runs and 1500 FPM (97.6 M/sec.) in vertical risers. Liquid lines shall be sized for a maximum pressure drop of 3 lbs. (1.36 kg.) from receiver to evaporator.
 10. Tubing runs shall be graded or pitched to prevent trapping of oil. Suction lines shall pitch 1/2"/10"-0" minimum.
- J. Joints and Connections
1. Fittings shall be long radius wrought copper only as manufactured by Mueller Brass Company or equal.
 2. Vertically run suction lines shall have one piece of manufactured oil "P" traps. Line to be sized for proper velocity for oil return to compressor(s).
 3. 1/8" NPT by 1/4 fl. half union for all suction and discharge service valves with 1/4 fl. cap.
 4. Reduction in piping size shall be made with a manufactured reducer coupling.
 5. Flare nuts shall be short forged or frost proof.
 6. All surfaces to be joined must be prepared and cleaned. When soldering stop or solenoid valves, wrap valves with moist fabric to absorb excessive heat. Stop valves shall be partly open. When soldering expansion valves or pressure regulating valves, remove power assembly, if necessary, to prevent damage by excessive heat.
 7. Copper joints shall be made with Handy & Harmon "Sil-Fos" brazing alloy, "Phoson 15", "Silvaloy 15" or equal; melting point of 1185-1350°F; (640°C. - 732°C.) silver content not less than 15%.
 8. Copper to brass joints shall be made with Handy & Harmon "Easy Flo 45" brazing alloy "Silvaloy 45", "Mueller 122" or equal; melting point of 1125-1145°F, (607°-618°C.) silver content not less than 45%.

- K. Hangers and Supports
1. For all piping not run in conduit, provide adjustable hangers, anchors or straps as required. Hanger spacing shall not exceed 8'-0".
 2. Insulated copper piping shall be provided with approved type sleeves at hanger points.
 3. All insulated copper piping shall be isolated from supports by means of felt wrapping or with "Trisolater" by Semco or approved equal.
 4. Vertical piping shall be supported at intervals with spring type hangers or a substantial pipe at case of the pipe. All horizontal pipe runs connected to vertical risers must be adequately supported.
 5. For suspended conduit, support shall be by means of hanger permitting screw adjustments. Sufficient hangers shall be used to provide support, allow expansion and limit vibration.
- L. Piping Sleeves
1. Provide sleeves through walls which allow for fully insulated lines. Extend sleeves entirely through wall and dress each end with a chromium plated wall plate neatly fitted against the wall, securely fastened and sealed in place. All sleeves through wall shall be of standard weight steel pipe.
 2. Piping lines and sleeves at wall or floor penetrations shall be caulked and made vermin proof at all locations.
- M. Piping Insulation
1. Suction lines run in conduit shall be insulated according to ambient and humidity conditions to prevent condensation and freezing.
 2. Refrigeration suction lines outside of refrigerated compartments, not run in conduit, shall be insulated back to compressors with Armstrong Armaflex AP foamed plastic insulation or as determined by code. Thickness of material shall suit service, ambient and humidity conditions, to prevent condensation, minimum thickness 1/2" (15 mm.).
 3. Cold Storage Room freezer drain lines extended through adjacent cooler compartments shall be insulated with 1/2" (15 mm) minimum thickness of Armstrong Armaflex AP foamed plastic insulation to prevent condensation. Carefully seal end of insulation tight against cooler wall surface.
 4. Piping for cooling water services or refrigerant piping exposed to freezing ambient temperatures shall be insulated with 1/2" (15 mm) minimum thickness of Armstrong Armaflex AP foamed plastic insulation. Paint exterior installation with Armaflex paint.
 5. Thickness of material shall suit service, ambient and humidity conditions to prevent condensation.
 6. Joints shall be sealed with Armstrong 520 adhesive. Insulation shall be continuous through clamps. Provide additional insulation where suction lines must be run within 12" or less of water or underground waste lines.
- N. Heat Interchangers
- All blower controls, unit coolers, plate type evaporators and other evaporators where specified, are to be provided with heat interchangers, with a capacity to match the condensing unit.
- O. Temperature Control
1. Temperature control of cold storage rooms shall be by line voltage thermostats operating liquid line solenoids.
 2. Temperature control for remote normal temperature refrigerator shall be by low pressure switch setting.

3. Temperature in each cold storage room compartment shall be controlled by electric thermostat, Ranco No. 010-1408, located within compartment and sensing element positioned to avoid fan discharge air stream.
- P. Valves and Accessories
1. All valves and controls shall be standard weight and suitable for service purpose intended, and subject to approval by the Designer.
 2. Provide shut-off valves and service port for each refrigerated fixture for multiplex installations to enable service personnel to service one (1) fixture while other fixture(s) connected to the same compressor can continue to operate.
 3. Each system shall include condensing unit with standard valving, refrigerant piping, refrigerant, evaporator(s), liquid and suction line isolation valves within 5'-0" (1500 mm) of evaporators, thermostatic expansion valve for evaporator, heat exchanger, filter-dryer, liquid line solenoids for Cold Storage Rooms and liquid indicator.
 4. Vibration eliminators on compressor suction and discharge lines, size same as piping, as manufactured by Anaconda.
 5. Refrigerant shut-off valves shall be as manufactured by Henry or Superior Valve Company. Valves shall be placed and in liquid line for each condensing unit and in each liquid line to each evaporator.
 6. Expansion valves shall be Sporlan, or approved equal, furnished and installed in the liquid line at the evaporator, unless provided with manufactured equipment. External equalizer expansion valves shall be provided for coils fitted with refrigerant distributor.
 7. A Sporlan, or approved equal, drier shall be provided at the compressor. Up to 3HP shall be a Catch-All series; larger than 3HP shall be angle replaceable cartridge series, or approved equal.
 8. Each liquid line sight glass shall be Sporlan "See All" moisture and liquid indicator and shall be full line size, or approved equal.
 9. Solenoid valves shall be Sporlan, or approved equal, line voltage, manual lift stem type, to operate at maximum of 2 lbs. (0.9kg.) pressure drop across the valve. Valves shall be full line size, using silver solder connection as applicable. A liquid line solenoid, normally closed, shall be used with temperature controller for each Cold Storage Room compartment coil on a system.
 10. Include a suction line filter with access valve adjacent to compressor. Filter shall be a Superior "F" Series or equal.
 11. EPR, CTR, and/or CDA valves shall be Alco or Sporlan, or approved equal.
 12. Suction accumulators shall be Refrigeration Research 3700 series or Virginia VA series, or approved equal.
 13. Discharge line mufflers shall be Refrigeration Research M-10 and M-15 or AC and RS S-6300 series, or approved equal.
 14. Time clocks shall be Paragon, or approved equal.
- Q. Drain Lines
- Type "L" copper coil drain lines extended to exterior of refrigerated compartments over floor sinks (drain) with "S" traps at termination ends.
1. Provide clean out "T" and cap at each change of direction in the lines. Provide individual drain lines for each coil unless otherwise specified. Drain lines shall be run tight to refrigeration compartment walls with minimum pitch of 2" per foot.

2. Drain lines inside low temperature compartments shall be equipped with drain line heaters wired by electrical division. Drain lines in low-temperature compartments shall be extended into adjacent, medium, or high temperature compartments to reduce length of drain line heater required. (Drain line in low temp compartment to be insulated with Armaflex ½" insulation by the Foodservice Equipment Contractor).
 3. Drain lines on the exterior of refrigerated compartment shall be painted with chrome tone paint.
- R. Refrigerant/Compressor Oil Reclaim
1. For existing refrigeration systems which may be reused, abandoned or where site conditions warrant, the system(s) refrigerant, oil and/or other components shall be reclaimed and contained by certified personnel in conformance to Refrigerants and Hazardous Waste criterion as specified by the Environmental Protection Agency and/or Montreal Protocol Guide Lines & Requirements.

PART 3 - EXECUTION

3.1 DELIVERY AND INSTALLATION

- A. Delivery
 - 1. The equipment shall be delivered and installed on schedule. Coordinate all work with the General Contractor and other divisions as required.
 - 2. Extra charges resulting from special handling or shipment shall be paid by the Food Service Equipment Contractor if insufficient time was allowed in placing factory orders to ensure normal shipment.
- B. The work shall be accomplished so as not to delay the project construction schedule, interfere or conflict with the work being performed by other contractors. Work shall be coordinated and integrated to prevent conflict of work necessitating changes to work already completed. Should conflicts occur, notify the Owner for his coordination in its resolution.
- C. Verify all required field dimensions before fabrication.
- D. Include all alternations to walls, floors and ceiling necessary for work, except otherwise shown or specified, accomplished in a manner satisfactory to the Architect and the Designer. Holes through structural beams shall be prohibited unless written approval has been granted by the Architect.
- E. Cut holes in equipment for pipe, drains, electric outlets, etc., as required for this installation. Work shall conform to highest standards of workmanship and shall include welded sleeves, collars, ferrules or escutcheons.
- F. Repair all damage to the premises as a result of this installation.
- G. Remove daily all debris from the site related to this installation.
- H. Remove any plates, components or component covers installed at the factory before installing the FRP-X panels at cold storage rooms and reinstall them afterwards along with the items furnished loose for mounting on the exterior face of the wall panels.
- I. Space between all equipment to wall, ceiling, floors, masonry pads, and adjoining units not portable and with enclosed bodies shall be completely sealed against entrance of food particles or vermin by means of trim strips, welding, soldering or mastic. Mastic shall be General Electric Silicone Construction Sealant Series SCS1200 (NSF approved) in appropriate color.
- J. Any exposed utility services down from above on the surface of a wall servicing food service equipment items are to be covered with an appropriately sized three sided stainless steel enclosure w/ #4 finish mechanically fastened to the wall.
- K. Trademarks and names of fabricator shall not be fastened to any items without written approval of Clevenger Frable LaVallee, Inc.
- L. All items shall be installed plumb, square, level and in proper elevation, plane location and in alignment with other work.
- M. Exposed rear and sides of food service equipment to be provided with finish to match front of unit.
- N. During delivery and installation, protect all equipment from abuse with materials (cardboard, masonite, bubble wrap, foam, etc) suited to the task. To obtain final approval, equipment needs to be provided free of "dings and dents".
- O. Cold Storage Rooms
 - 1. The cold storage rooms shall be delivered and installed on schedule by factory supervised and approved installers. Coordinate the work with the General Contractor and other trades as necessary.
 - 2. Become fully familiar with the job site and the architectural drawings and

specifications. Provide the necessary job site coordination with the various trades to insure job site conditions will meet the requirements of the cold storage rooms.

3. Establish a time schedule with the General Contractor that will insure the job site coordination with the various trades to insure job site conditions will meet the requirements of the cold storage rooms.
4. All work shall be designed and manufactured to comply with field conditions and fitted with proper joints and sections.
5. During curing and cleaning of the wearing floors inside the cold storage rooms, the cold storage room doors shall be left open and the rooms well ventilated to prevent damage to the interior. "Keep Out" signs shall be posted at each open door.
6. After the installation of the cold storage rooms and prior to the installation of the wearing floor and after the wearing floor has cured, the cold storage room doors are to be closed and locked.
7. Where the floor is depressed or floorless, walls shall be anchored to the building floor with a concealed 18 gauge galvanized steel floor track with drive pins 2'-0" on center and sealed at interior and exterior edges with a bead of sealant.

P. Refrigeration Systems

1. Refrigeration systems and connecting piping shall be installed as indicated in contract documents in a manner that provides complete and operational systems and eliminates any noise and vibration being transmitted to any part of the building.
2. Piping shall be installed to permit normal inspection, service, removal of the condensing units and their components and view of sight glasses and allow expansion and contraction without damage to the system.
3. Extreme care shall be taken to keep the entire system clean and dry.
4. Nitrogen gas shall flow through piping being welded to prevent scaling. The Owner or Designer shall have the option of cutting a maximum of three (3) welded fittings to inspect for the proper use of nitrogen. Food Service Equipment Contractor shall replace fittings at his cost where scaling is present.
5. Suction and discharge line vibration eliminators shall be furnished and installed parallel to the compressor shaft and secured at outlet end as required to eliminate vibration in rigid piping.
6. All refrigeration lines shall be factory extended to one end of the compressor rack in a neat and orderly manner and shall be supported and anchored with "Unistrut" or equal clamps and channels. Ends of lines shall be capped against contamination.
7. Compressors and all accessories on the compressor rack shall be factory mounted and pre-wired to a main circuit breaker control panel with individual circuit breakers wired to a main breaker disconnect requiring a single power connection. All wiring shall be run inside a code approved raceway.
8. Condenser water supply and return header shall be factory pre-plumbed using hard copper tubing with shut-off valves for supply and return for each.
 - a) Provisions shall be provided for connection to city water for emergency use.
 - b) Verify water system pressure and provide all necessary components to insure proper operation of the water cooled system and the return

- of the water to the recirculating system.
9. If, in the opinion of the Food Service Equipment Contractor, additional ventilation is required to ensure correct operating temperatures, he shall so state in a letter to Owner and/or Designer for evaluation and decision before installation.
- Q. Refrigeration System Instructions and Identification
1. Food Service Equipment Contractor shall at each component of every system identify it with the letter/number shown on the Refrigeration Schedule. The identification shall be with black paint, decal, or other approved permanent method. Plastic tape labels are unacceptable. Identification shall be in an easily seen location.
- R. Refrigeration Piping Testing
1. Notify Owner and/or Designer in advance when a test is being made and ready for inspection.
 2. Each system shall be pressure tested for leaks. All valves shall be fully open during the test.
 3. Tests are to be accomplished as follows:
 - a) Charge the systems with refrigerant through the port of liquid shut off valves of the receivers to a pressure of 10 to 20 p.s.i.
 - b) Add dry nitrogen, the supply of which shall be equipped with a pressure regulating valve to provide the specified pressure.
 - c) Carefully test all joints for leaks using either a Halide torch or an electronic Halogen leak detector.
 4. The Owner or Designer shall approve all tests.
 5. Precautions shall be taken to disconnect the low pressure controls for protection of the bellows during testing.
- S. Refrigeration System Evacuation
1. Advise Owner and/or Designer when the evacuation of the system is to start, so the procedures can be checked.
 2. Evacuation shall be with an Airserco, Stroke KC8R or Robinaire, 150021 vacuum pump with an indicating gauge registering pressure in microns. Pump shall be connected to the system with a 5/8" O.D. line or larger.
 3. Evacuate both high and low sides to 500 microns. Break the vacuum with refrigerant to 0 p.s.i. evacuate the high and low sides below 500 microns; Break the vacuum with refrigerant; evacuate high and low sides to 100 microns; and then break vacuum to 0 p.s.i. with the refrigerant to be used in the system.
- T. Foodservice Equipment Contractor to confirm installation requirements with food service equipment manufacturer where equipment units penetrate the counter top [stainless steel, plastic laminate, solid surface, stone (natural & man-made)]. Foodservice equipment Contractor to coordinate installation requirements suggested by the manufacturer with the Millwork Contractor.
- 3.2 START-UP & DEMONSTRATION
- A. All equipment under this section shall be cleaned and ready for operation at time building is turned over to the Owner.
 - B. Provide a factory authorized service representative to be present when installation is put into operation. Per the manufacturer's recommendations, he shall put into proper operation per the manufacturer's recommendations all equipment and instruct the Owner's employees in the proper use and maintenance of all items in

- this contract.
- C. Where engineered systems are specified that require specialized knowledge/skill to put equipment into operation (including, but not limited to ventless hoods, tray accumulators, combination oven steamers, utility distribution systems, water wash control panels, refrigeration rack systems, conveyor type dishmachines, single tank upright dishmachines, flight type dishmachines, pulper systems, conveyORIZED soiled dishtable assemblies, cook-chill systems and their major components, cooking suites, potwashing machines and conveyORIZED tray make-up systems, etc.) the Food Service Equipment Contractor is to provide start-up and adjustment per the manufacturer's recommendations by a factory trained service technician. The Food Service Equipment Contractor will include start-up and adjustment per the manufacturer's recommendations by a factory trained service technician and authorized by the manufacturer for starting up the equipment and putting it into operation in concert with related work performed by other divisions shall be included in their pricing proposal for all aforementioned items.
 - D. At the completion of the start - up procedure, the Food Service Equipment Contractor will provide documentation to the Owner which is prepared by the service agent indicating that the equipment was put into operation per the manufacturer's recommendations.
 - E. All accessory items listed in the itemized specifications section are the responsibility of the foodservice equipment contractor. Careful review of these accessories are required as they may not all be available from the manufacturer. Detail C-2-3B, Cutting Board w/Bracket may be listed in the itemized specifications as an accessory to a Jade griddle. This item is not available from Jade. The Foodservice Equipment Contractor will obtain this item from the appropriate source (custom fabricator) to fulfill the specifications
 - F. Refrigeration System Start-up
 1. Charge each system with the refrigerant specified in the Refrigeration Schedule.
 2. All systems and controls shall be set and checked for proper operation at temperatures specified in the Refrigeration Schedule.
 3. Check compressors for proper oil level. Refrigerant oil shall be Suniso 3G, inhibited only, delivered to job site in sealed containers. Oil shall be added to the system to maintain 1/4" to 1/2" sight glass.
 4. Check all electrical circuits by Division 26 - Electrical for compliance with the manufacturer's specifications. Division 26 - Electrical shall make corrections to his wiring as required. The Food Service Equipment Contractor shall be responsible for corrections in his wiring and/or components as required.
 5. The manufacturer's requirements for lubrication shall be checked and followed before the operation of fan and pump motors, and/or associated equipment.
 6. Furnish and install, where directed by the Owner, copies of the Refrigeration Schedule and Refrigeration Floor Plan, framed with a glass covering. The Refrigeration Floor Plan shall show the location of all EPR, CTR, and/or CDA valves, solenoid valves, and other controls for easy location and services.
 7. Provide a set of "As Built Drawings" to Owner upon completing the installation. Drawings shall include refrigeration line runs and wiring diagrams. Drawings shall be submitted in the form of reproducible sepias.

- G. Review the refrigeration systems, operation, maintenance, emergency procedures, and proper service procedures with the Owner's Engineering Staff. Provide a competent serviceman who shall remain for a minimum of eight (8) hours during the first day of operations.
- H. Where concrete has been poured inside a low temperature cold storage room it shall be allowed to cure twenty-eight (28) days, minimum seven (7) days before starting the refrigeration system. After the curing period the temperature shall be brought down in regulated stages. The temperature shall be brought down as follows: to 40°F. (5°C.) held twenty-four (24) hours; to 20°F. (-6°C.) held twenty-four (24) hours; and then to specified temperature.
- I. During start-up provide all required instruction for operation and maintenance of equipment, after one year guarantee period.
- J. The fire suppression system shall be tested for the authorities in the Owner's presence. Certificates shall be obtained and provided to the Owner from the authorities and from the Fire Insurance Rating Bureau.
- K. After installation and hook-up, verify air volumes at each exhaust and make-up air duct. A report shall be submitted to the Owner of all readings. All incorrect air volumes shall be rechecked after adjustment.

3.3 MAINTENANCE SCHEDULE

- A. Provide final operation warranty and service inspections thirty (30) days before warranty expiration. Any service or repair requirements shall be performed before the end of the warranty period.
- B. Copies of all warranty service calls and inspection reports shall be mailed to the Owner and building operations engineer.
- C. The Owner may call an outside company at the expense of the Food Service Equipment Contractor, if the Food Service Equipment Contractor does not arrive within four (4) hours of the time called in response to an emergency call.

PART 4 - EQUIPMENT

4.1 REGULAR MANUFACTURED EQUIPMENT

- A. Provide equipment with standard finishes and accessories unless specifically deleted or superseded by the contract documents.

4.2 FABRICATED EQUIPMENT

- A. Provide arrangement and configuration as shown on plans, elevations and standard detail drawings.

4.3 BID QUOTATION SUMMARY FORM

- A. Proposals submitted for this project that do not include and itemized schedule of values consistent with the equipment schedule will be rejected.

Bid Quotation Summary Form

Total Bid Pricing with/

	Prime Specifications	Mandatory Alternates	Approved Alternates
Subtotal Equipment			
Delivery			
Installation			
Taxes			
Grand Total			
Performance Bond			

FSE Contractor to Furnish the names of Sub-Contractors:

Stainless Steel Fabricator _____
 Millwork Fabricator _____
 Refrigeration Contractor _____
 Installer _____

We Acknowledge Addendum(s) _____, Dated _____ the above bid is in Accordance with the Bid Documents, Except as Noted.

The Undersigned Acknowledges That They Have Read and Understand the Instructions to Bidders, General Conditions and Specific Conditions and, If The Successful Bidder, Will Fully Comply With All Articles and Sections Contained Therein.

Firm _____
 Signature _____
 Print Name _____
 Date _____

4.4 FOOD SERVICE EQUIPMENT SPECIFICATIONS

ITEM #1 EXHAUST HOOD

Quantity: One (1)

Manufacturer: Captive-Aire

Model: 6024AM-ND-2

The model ND-2 is an exhaust only canopy hood rated for all types of cooking equipment. The hood shall have the size, shape and performance specified on drawings and mounted 6'-8" AFF. Construction shall be type 300 stainless steel series with a #4 polish where exposed. The use of galvanized steel, or 430 stainless steel is not acceptable. Individual component construction shall be determined by the manufacturer and ETL. Construction shall be dependent on the structural application to minimize distortion and other defects. All seams, joints and penetrations of the hood enclosure to the lower outermost perimeter that directs and captures grease-laden vapor and exhaust gases shall have a liquid-tight continuous external weld in accordance with NFPA 96.

Hood shall be wall type with a minimum of four connections for hanger rods. Corner hanging angles have a 5/8" x 1-1/2" slot pre-punched at the factory, allowing hanging rods to be used for quick and safe installation. The hood shall be furnished with

U.L. classified filters, supplied in size and quantity as required by ventilator.

The hood manufacturer shall supply complete computer generated submittal drawings including hood sections view(s) and hood plan view(s).

These drawings must be available to the engineer, architect and owner for their use in construction, operation and maintenance.

Exhaust duct collar to be 4" high with 1" flange. Duct sizes, CFM and static pressure requirements shall be as shown on drawings. Static pressure requirements shall be precise and accurate; air velocity and volume information shall be accurate within 1-ft increments along the length of the ventilator.

U.L. Listed recessed Allanson round LED fixtures and LED lights shall be installed and pre-wired to a junction box. The light fixtures shall be installed with a maximum of 4'0" spacing on center and allow up to a standard light bulb.

The hood shall have:

A double wall insulated front to eliminate condensation and increase rigidity. The insulation shall have a flexural modulus of 475 EI, meet UL 181 requirements and be in accordance with NFPA and 90B.

An integral front baffle to direct grease laden vapors toward the exhaust filter bank.

A built-in wiring chase provided for outlets and electrical controls on the hood face and shall not penetrate the capture area or require an external chaseway.

Removable grease cup for easy cleaning.

RTD Temperature sensor(s) for each duct.

One (1) lot stainless steel enclosure paneling, at all open sides, to finished ceiling (F.S.E. Contractor to verify height). Paneling must be supplied by Exhaust Hood Manufacturer and installed by F.S.E. Contractor. Adhere to Specific Conditions for installation of fabricated equipment.

Ventilator to be U.L. and NSF listed and be in full accordance with NFPA 96 and all state/local codes/ordinances applicable.

F.S.E. Contractor to supply the necessary mounting rods for hanging ventilator.

The hood shall be ETL Listed as "Exhaust Hood Without Exhaust Damper", ETL Sanitation Listed and built in accordance with NFPA 96. The hood shall be listed for 450°F cooking surfaces at 150 CFM/ft, 600°F cooking surfaces at 200 CFM/ft, and 700°F cooking surfaces at 250 CFM/ft.

Options:

Utility Cabinet with Fire Suppression System on Right side.

Captrate Combo, Captrate Solo, stainless steel baffle, aluminum baffle, and high velocity cartridge filters Pre-piping of the Item 2, Fire Suppression System is to be provided by the Exhaust Hood manufacturer at the time of hood fabrication.

Pre-piping to include fusible-link detector bracket assemblies and cable runs, and wet-chemical manifold piping, duct collar and plenum protection piping with termination nozzles, and cooking appliance nozzle drops with termination nozzles.

Location of cooking appliance nozzle drops are to be fully dimensioned on hood submission drawings.

Fusible link detector and wet chemical piping terminations to be coordinated with the FSE Contractor and clearly indicated on hood submission drawings.

Access to the fusible links for inspection and change-outs to be provided. The hood manufacturer and FSE Contractor to coordinate their efforts to assure the necessary access.

Supply air plenum boxes w/ full length internal removable baffle mounted at finished ceiling height.

Refer to preliminary drawings #4898410

FSE Contractor is responsible for fit of equipment. Prior to releasing hoods for fabrication, FSE Contractor needs to verify field conditions (existing &/or proposed) and to determine clearances to all structural items, obstructions, etc. The FSE Contractor will coordinate with other trades to confirm that the hood can be mounted as proposed and that the ductwork and final connection can be accommodated without conflict. Failure to perform this step may result in modifications to the exhaust hood at the FSE Contractor's expense.

ITEM #2 FIRE SUPPRESSION SYSTEM

Quantity: One (1)

Manufacturer: Ansul

Model: R-102

Fire protection system to be provided and installed by FSE Contractor per detail C-22-6 and C-22-7. System to be Ansul R102 system, wet chemical with the following specifications:

Wet chemical suppressant.

System U.L.300 listed, installed in accordance with manufacturer's recommendations, and comply with NFPA 17A, NFPA 96 and all applicable codes.

System to be pre-piped and fusible link detection incorporated with ventilator sections by ventilator manufacturer at time of construction.

Wherever possible, system piping shall be concealed. Exposed piping, conduit and nozzles shall be smooth chrome-plated or stainless steel.

Fusible link assemblies shall be unexposed within the ventilator bodies or within enclosed boxes recessed into ventilator roof.

System shall be shipped complete with tanks, automan release, remote manual release.

Cylinders and controls shall be mounted on wall where shown on plan tight to underside of finished ceiling and not conflict with equipment below. Junction boxes for connections to Automan to be located above finished ceiling.

Mechanically activated gas shut off valve with mechanical reset is to be furnished by the FSE Contractor and installed by the Plumbing Contractor.

Coordination and cabling to valve by FSE Contractor.

Shunt trip type breaker disconnect provided and installed by the Electrical Division.

FSE Contractor to coordinate shunt trip breaker requirements with the Electrical Contractor.

System to provide plenum and duct collar protection and surface protection for equipment underneath Item 1, Exhaust Hood.

FSE Contractor will be required to obtain all permits and arrange for system inspection and testing to achieve an approved operating system.

FSE Contractor to coordinate with Electrical Division for connection to building alarm system.

Operator to return mobile appliances to correct position below surface protection nozzles after cleaning.

Provide UL listed ANSUL flexible fire suppression distribution hose with permanent UL approved restraining cable for salamander broilers and similar cooking devices mounted on castered appliances.

Remote pull station:

- Fire Protection System remote manual activation stations are to be recessed wall-mounted, with the cabling conduit recessed within the wall.
- Remote pull stations are to be located along pathways between the protected equipment and area exits, and in accord with any governing local code requirements and/ or system manufacturer recommendations. FSE Contractor to confirm placement of remote fire pulls w/ Fire Suppression System Subcontractor and reflect code compliant placement on dimensioned rough-in plans.
- FSE Contractor shall coordinate the efforts between the Fire Protection System subcontractor, any other trades, and with local code enforcement officials, as may be necessary to comply with local codes.
- If the FSE contractor determines that, for any reason, the flush mounting of the remote fire pulls is not possible an appropriate and timely "Inability to Comply" statement must be furnished to Foodservice Consultant for their review and response.

ITEM #3 WALL FLASHING
Quantity: One (1)
Manufacturer: CFLFAB
Model: WALL FLASHING

Provide 20 ga. stainless steel wall flashing, approximately 19'-6' per detail C-2-11. Stainless steel flashing to extend from floor or top of wall tile base to underside of Item 1, Exhaust Hood.

- Equal sections.

ITEM #4 CONVECTION OVEN, DOUBLE, GAS
Quantity: One (1)
Manufacturer: Blodgett
Model: DFG-100 DBL

Convection Oven, gas, double-deck, standard depth, capacity (5) 18" x 26" pans per compartment, (SSD) solid state digital controls, 2-speed fans, interior light, simultaneous operated doors with glass, stainless steel front, sides & top, 6" stainless steel legs, flue connector, (2) 1/2 HP, 55,000 BTU each, cETL, NSF, CE

- 3 year parts, 2 year labor and 2 additional year door warranty (parts only), standard
- Natural gas
- 115v/60/1-ph, 6.0 amps, 1/2 hp, 2-wire with ground, NEMA 5-15P (per deck), standard
- Top Oven: Solid State digital with Pulse Plus and Cook & Hold, standard
- Bottom Oven: Solid State digital with Pulse Plus and Cook & Hold, standard
- Draft diverter or Draft hood must be selected below
- 4" low profile plate casters (set)
- Gas manifold
- 48" flexible gas hose with quick disconnect 2 Swivel Max Swivel & restraining device

ITEM #5 GAS COUNTERTOP GRIDDLE
Quantity: One (1)
Manufacturer: Vulcan
Model: 948RX-30

Heavy Duty Griddle, countertop, gas, 48" W x 30" D cooking surface, 1" thick polished steel griddle plate, embedded mechanical snap action thermostat every 12", millivolt pilot safety, electric spark or manual ignition, front manifold gas shut-off valve, low profile, stainless steel front, sides, front grease trough, 4" back & tapered side splashes, 4" adjustable legs, 108,000 BTU, CSA, NSF

- 1 year limited parts & labor warranty, standard
- Natural gas (specify elevation if over 2,000 ft.)
- 120v/50/60/1-ph, 1.0 amp, NEMA 5-15P, standard
- Equipment Stand, universal, 49" W x 24" H, 1/2" marine edge, undershelf, stainless steel, 5" casters
- 48" flexible gas hose with quick disconnect 2 Swivel Max Swivel & restraining device.
- Cutting board accessory with 3/4" thick Richlite cutting board.

ITEM #6 RANGE, 4 OPEN BURNERS
Quantity: One (1)
Manufacturer: Vulcan
Model: V4B36S

V Series Heavy Duty Range, gas, 36", (4) 35,000 BTU open burners, cast iron grates, standard oven, stainless steel front, front top ledge, sides, base, burner box & stub back, 190,000 BTU, 6" adjustable legs, CSA, NSF

- 1 year limited parts & labor warranty, standard
- Natural gas (specify elevation if over 2,000 ft.)
- 1" NPT pressure regulator with reducer (Natural gas)
- 1-1/4" rear gas connection, standard
- Rear gas connection: cap & cover, both ends
- Single-deck flow-thru hi-shelf, non-overlapping, 36"
- Casters, 6", adjustable (set of 4) (2 with locks)
- 48" flexible gas hose with quick disconnect 2 Swivel Max Swivel & restraining device

ITEM #7 TILTING SKILLET BRAISING PAN, GAS
Quantity: One (1)
Manufacturer: Cleveland Range
Model: SGL30TR

DuraPan Tilting Skillet, gas, 30-gallon capacity, modular open base, standard with hydraulic hand tilt with quick lowering feature, stainless steel construction, includes spring-assisted cover, gallon markings and electronic spark ignition, stainless steel level adjustable feet, CE, NSF, 91,000 BTU, IPX6

- 1-year parts & labor warranty, standard
- Performance start-up included at customer request after equipment is installed (Free Water Quality Check included) (contact Cleveland Sales Representative for details)
- Natural Gas
- 120v/60/1-ph, 1.8 amps NEMA 5-15P, standard
- Power Tilt, with hand tilt override
- 2" tangent draw-off valve, front mounted left side (Note: May require additional lead time, contact factory)
- Double Pantry Faucet and Bracket.

ITEM #8 FLOOR TROUGH
Quantity: One (1)
Manufacturer: IMC/Teddy
Model: ASFT-2424-SGAS

Unit of size, shape and location shown on plan.

This item to be set and installed by General Contractor.

Quarry tile floor finish to be etched, if required, prior to setting food service equipment in place.

Provide grating sections of equal size not to exceed 20" long. Removal of grating to be unobstructed by adjacent equipment.

Provide shop drawings of size and scale outlined in specific conditions.

Coordinate structural conditions and floor penetrations with General Contractor. Fabricate trough depth and connections accordingly.

Confirm finished flooring type with Architect. Coordinate flange type w/ manufacturer.

- Grating to be anti-slip (top & bottom), stainless steel.
- Anti-splash floor trough, 6" deep].
- Seepage flange and "weep" holes (for above grade application only).

ITEM #9 HAND SINK
Quantity: Two (2)
Manufacturer: Eagle
Model: HSA-10-F

Hand Sink, wall mount, 13-1/2" wide x 9-3/4" front-to-back x 6-3/4" deep bowl, 304 stainless steel construction, splash mount gooseneck faucet, basket drain, deep-drawn seamless design-positive drain, inverted "V" edge, NSF

- Wrist Handles for faucet, NSF

ITEM #10 SPARE NO.

ITEM #11 REACH-IN FREEZER
Quantity: Two (2)
Manufacturer: Continental Refrigerator
Model: 2FENSA

Extra-Wide Freezer, reach-in, 57"W, two-section, self-contained refrigeration, stainless steel exterior, aluminum interior, standard depth, full-height solid doors, cylinder locks, electronic control with digital display, unit can be adjusted to operate as low as -10°F, hi-low alarm, electric condensate evaporator, R290 Hydrocarbon refrigerant, 1/2 HP, cETLus, NSF, Made in USA, ENERGY STAR

- Standard warranty (for the United States & Canada Only): 3 year parts and labor; additional 4 year compressor part
- 115v/60/1-ph, 9.0 amps, cord, NEMA 5-15P, standard
- Left Door hinged on left & right door hinged on right, standard
- Casters, swivel, with brakes (5" diameter rubber tires) set of 4 (6" height)

ITEM #12 MOP SINK CABINET
Quantity: One (1)
Manufacturer: Eagle Group
Model: F1916-VSCS

Mop Sink Cabinet, single width, 25"W x 22-1/4"D x 84-1/4"H, slanted top, holds (2) mops, (2) hinged doors with transverse rod handles & keyed locks, 8" deep mop sink with service faucet, (1) 12"D fixed overhead shelf, includes 30" spray hose & spray hose bracket, 430 stainless steel construction, NSF

- Upgrade to type 300 stainless steel cabinet, add -SE to model number

ITEM #13 TABLE, ISLAND TYPE
Quantity: One (1)
Manufacturer: LTI
Model: Custom Fabrication

Unit to be of size and shape as shown on plan x 36" high per details C-1-1A Type "A" and C-7-1C.

- Mount on set of 5" diameter polyurethane swivel casters, two (2) diagonal with brakes.
- Undershelf per C-7-1C.
- 20" x 20" x 5" deep utility drawer constructed similar to details C-1-3A, C-1-3C and C-1-3D, No lock hasp.
- Angle slides at bottom of drawer w/ one (1) Richlite 1/2" thick cutting board per detail C-1-3C.

ITEM #14 TABLE W/SINKS
Quantity: One (1)
Manufacturer: LTI
Model: Custom Fabrication

Unit to be of size and shape as shown on plan x 36" high per details C-1-1A Type "A" and C-7-1B.

- Provide shelf, table mounted, single tier of size and shape as shown on plan per details C-7-8.
- Two (2) compartment sink; sink bowls to be 20" x 20" x 12" deep. Provide each sink with Type 1 rotary waste. Provide Type 3 faucet. Construction similar to C-7-1B.
- Provide 120 volt receptacle and empty J-box in stainless steel bracket mounted to underside of table. (as shown on electrical plan)
- Provide unit with undershelf right and left of sinks per C-7-1C.
- Apron across sink bowls.
- Rear crossrails.

ITEM #15 THREE (3) COMPARTMENT SINK
Quantity: One (1)
Manufacturer: LTI
Model: Custom Fabrication

Unit to be of size and shape as shown on plan x 34" high to drainboard level with 10" high splash per details C-1-1A Type "D" edge, C-1-1B backsplash, C-8-1 and C-8-5. (Define) end splashes as shown on plan. (3) sinks - wash 24", rinse 24", sanitize 24", all 14" deep with flush front construction and the following requirements:

- Open base type table, no undershelves.
- Front to back and rear crossrails.
- Two Type 1 faucets w/ 12" spouts.

ITEM #16 SHELF, TWO-TIER, WALL MOUNTED
Quantity: One (1)
Manufacturer: LTI
Model: Custom Fabrication

Unit to be of size and shape as shown on plan per detail C-1-2 with the following requirements:

- Louvers per detail C-1-2D - laser cut.
- Two tier unit.
- Two-tier unit, first tier (lower shelf) to be 12" wide, second tier (upper) to be 15" wide.

ITEM #17 POT & PAN SHELIVING RACK
Quantity: One (1)
Manufacturer: Metro
Model: PR48ES

Mobile Pot & Pan Rack, 48"W x 24"D x 68"H, (4) shelves solid embossed stainless steel (2) 5MP polyurethane swivel casters & (2) 5MPB polyurethane swivel casters with brake, NSF

ITEM #18 HOT CABINET, MOBILE
Quantity: One (1)
Manufacturer: Winston Foodservice
Model: HL4022-AL

CVap Low Wattage Holding Cabinet, full-size, insulated, without fan, adjustable universal wire slides, 3-1/2" OC, accommodates (14) 18" x 26" or (28) 12" x 20" or (14) 2/1 GN pans, 90°F to 180°F temperature range, (2) hinged solid dutch doors with magnetic latch, electronic differential controls, digital display, manual water fill, stainless steel interior, aluminum exterior, NSF, CE, UL, cUL, UL-Sanitation

- 1 year limited warranty is standard (excluding gaskets, lamps, hoses, power cords, glass panels & evaporators) - for equipment operated in the US & Canada
- 120v/60/1-ph, 1685 watts, 14.0 amps, (US) NEMA 5-15P
- Left-hand
- Locking door handle (per door)
- H3 3" swivel casters (2) with brakes, standard

ITEM #19 COUNTER W/SINK
Quantity: One (1)
Manufacturer: LTI
Model: Custom Fabrication

Unit to be of size and shape as shown on plan x 36" high w/ 6" splash per detail C-1-1A Type "A" edge, C-1-1B Type "A" backsplash and C-2-1. Provide with the following:

- Sink compartment w/undershelf and hinged door per detail C-2-2 and C-2-1E.
- 16" x 20" x 10" deep sink w/ Type 3 faucet.
- Equal double pan doors, hinged per plan and constructed per detail C-2-2, horizontal pull.
- Adjustable intermediate shelf behind each door.

ITEM #20 MILK COOLER
Quantity: One (1)
Manufacturer: Nor-Lake
Model: AR122SSS/0-A

Open Front Milk Cooler, 48-5/8" W, drop front, 12 case capacity, (3) heavy duty floor racks, thermometer, stainless steel exterior and interior, four corner bumpers, locking swivel casters, 1/5 HP, 115v/60/1-ph, 3.1 amps, cord, NEMA 5-15P, UL, cUL, UL-Sanitation

- Standard warranty: 3 year parts and labor warranty, 5 year compressor
- Replacement Parts warranty: 90 day warranty on replacement parts
- Plug into receptacle provide as part of Item 21.

ITEM #21 SERVING COUNTER, HOT FOOD, ELECTRIC
Quantity: One (1)
Manufacturer: LTI
Model: SLBT1732-HC

Top: Solid surface tops to be fabricated from 1/2" thick Dupont Corian, color selected by architect/owner. Solid surface to be installed onto the counter with a 3/4" plywood substrate. Solid surface top to have 2" eased edge on all sides. All counter tops to have a one-piece appearance with no visible seams and edges to be polished smooth and to include cut-outs as required for drop-ins. All cut-outs to be fully supported with proper framing support. All cut-outs for hot items will be provided with a thermal shield, vertical support frame to support thermal frame off the surface of the top and wrapped with Nomex Thermal material. Provide properly sized plastic grommets for cut-outs that require them. Top to measure 204" L X 32" W X 32" or 34" H.

Body: The body is to be manufactured with an 11-gauge galvanized steel frame. The 1/8" thick steel to be precision cut by a computer operated laser to ensure exact fit and finish, resulting in a square and level final counter. At each corner, the framework will include an 11-gauge triangular steel support for additional strength. Additional 1 1/2" x 1 1/2" x 1/8" galvanized angle frame will be welded to the framework where required for increased strength and support. Body exterior to be fabricated from 18-gauge stainless steel panels to be made removable to allow for service access. Working side of counter body to have 18-gauge stainless steel. Provide stainless steel lower shelves where possible for storage on the operators' side. Make shelves removable for cleaning. Provide a convenience outlet, flush mount type, to be 120VAC or 208VAC, prewired and fused as required as shown on drawings. Receptacle to be recessed in stainless steel housing on a body surface to accept owner supplied milk cooler
Body to be two different heights as shown on drawings and will be internally bolted to provide a seamless look.

Food Shield: Over the hot food and convertible well section provide a straight front tempered glass full-service protector case, to consist of all component hardware CNC machined in 6061-T6 aluminum to +/- 002". End and top glass panels are 3/8" clear tempered. Both meet ANSI Z97.1 specification for safety and performance and ASTM C1048-04 specifications for heat treated glass. All hardware supplied in a satin clear anodized aluminum finish. All glass with ground and polished edges. Provide with heat lamps and led lights where indicated on drawings. Protector cases to be surface mounted with no exposed screw heads.

Food Shield: Over the cold pan section provide a straight front tempered glass self-service buffet shield, to consist of all component hardware CNC machined in 6061-T6 aluminum to +/- 002". End and top glass panels are 3/8" clear tempered. Both meet ANSI Z97.1 specification for safety and performance and ASTM C1048-04 specifications for heat treated glass. All hardware supplied in a satin clear anodized aluminum finish. All glass with ground and polished edges. Provide with led lights where indicated on drawings. Food shield to be surface mounted with no exposed screw heads.

Provide 4 ea. model DI-TW-4T TW Series Hot Food Wells. Dry moist electric hot food wells to be die-stamped stainless steel pans with 1/4" raised beaded edge. Wells to be bottom mounted. Interior pan to be 18-gauge, 304 stainless-steel, deep drawn with coved corners and fully insulated with fiberglass insulation. The exterior jacket to be constructed with 18-gauge stainless steel. Each hot food well to use a 500-watt heat source with solid state digital controls for maximum energy efficiency. Provide with touch pad digital controller. All controls to be fully accessible. All wells are wired to a circuit breaker for current overload protection. Wells to be UL listed and approved. Wells to have concealed elements and can be used either dry or wet. Drains to be plumbed into the storage base below and location determined at shop drawing review.

All equipment to be built in accordance with the Underwriters Laboratories, Inc. and the National Sanitation Foundation, Inc. standards and shall bear the Underwriters Laboratories, Inc. listing label for safety and the Underwriters Laboratories classification label for sanitation.

Continuous tray slide, full length mounted at 30" AFF. 14 ga. s/s w/ 1/2" inverted "V" edge, stainless steel fixed brackets.

Daisy chained assembly w/ cord and plug to Item 25, Cashier Counter as shown on CFL drawing KA-3, Electrical Plan.

Provide per preliminary shop drawing OPT11959 dated 6/4/21.

ITEM #22 COLD FOOD WELL UNIT, DROP-IN, REFRIGERATED
Quantity: One (1)
Manufacturer: LTI
Model: DI-QSCHFP-1-T

Provide a convertible Hot/Cold Unit where shown on drawings. Well to be individual 12" x 20" opening. Well to have the ability to either; heat, refrigerate, or hold frozen product. All wells to be individually operated with separate controls and drains. Unit to be constructed of 14-gauge 304 stainless steel, welded, ground and polished with a thermal break provided between the top and refrigerated interior. Interior pan to be 18-gauge 304 stainless steel, fully welded, ground and polished with a 3/4" open drain. Unit to be fully insulated with 2-1/2" to 3" urethane insulation. The exterior jacket to be constructed of heavy gauge stainless steel. Refrigeration system to be a hermetically sealed compressor operating on R-507 (HFC) refrigerant and will include controls. Well to also operate as an energy efficient hot food well using a 500-watt heat source digitally controlled. Hugged edge.

Daisy chained assembly w/ cord and plug to Item 25, Cashier Counter as shown on CFL drawing KA-3, Electrical Plan.

Provide per preliminary shop drawing OPT11959 dated 6/4/21.

ITEM #23 SERVING COUNTER, COLD FOOD
Quantity: One (1)
Manufacturer: LTI

Body of unit and food shield specified as part of Item 21.

Provide Model DI-2050TA-T, Tempest Aire Cold Pan, a 4 pan, mechanically cooled cold pan to be 18-gauge stainless steel fully welded construction with ¼" covered corners. Cold pan to be pitched to a standard 1" brass drain, which is extended to value below the base. All cold pans to be furnished with urethane insulation on the bottom and all four sides of the pan. The exterior of the insulation is jacketed in a galvanized housing. Pan to be fully separated from the counter-top by a full perimeter breaker strip. Cold pans are to allow for all size steam table pans, 6" deep. Temp-est Aire cold pan shall be 9" deep and include a patented forced air refrigeration system. Cold pan includes low velocity fan(s) and an advanced cold wall design operation on R-507 refrigerant. **Cold pan to meet or exceed NSF7 standards while allowing food pans to remain flush to the counter-top.**

Provide cross ventilated compressor housings in rear of refrigerated counter with removable louvered access panels to allow for ease of service. Front of housing to be left open to allow for maximum ventilation. Interior of housing to have easy access slide-out channels to accommodate condensing unit. Condensing unit to contain a fully hermetic condensing unit connected to the cold pan with all necessary controls for proper operation. System to be hooked-up, tested in the factory, and made ready to be plugged in on the job. Condensing unit to be properly sized to the evaporator load.

Daisy chained assembly w/ cord and plug to Item 25, Cashier Counter as shown on CFL drawing KA-3, Electrical Plan.

Provide per preliminary shop drawing OPT11959 dated 6/4/21.

ITEM #24 SPARE NO.

ITEM #25 CASH REGISTER STAND
Quantity: One (1)
Manufacturer: LTI

Body of unit and food shield specified as part of Item 21.

- Provide an 18-gauge stainless steel cashier liner center of counter as shown on drawing. Provide a drawer assembly: non-locking, to have 18-gauge stainless steel removable pan. Pan to be 20"x20"x5" deep, one piece, die stamped with fully covered corners. 16 gauge stainless, steel drawer face complete with integral handle. Set-in stainless-steel channel frame and mounted on roller bearing slides. Provide 1 pull out shelf at cashier section. Provide and install a convenience outlet, flush mount type, to be 120VAC/15 amp, prewired and fused as required data, wired to junction box below. Provide recessed into face of cashier liner a data cable port for POS supplied by owner. Counter height to be 34". Knockout with grommet for POS terminal.

Daisy chained assembly cord and plug, single connection, NEMA-14-50P, serves Items 20, 21, 22 and 23. POS not included in this load.

ITEM #26 POS TERMINAL
Quantity: One (1)
Status: By Owner

This item is not in contract.

The specification is for reference only.

The item is shown on the drawing for informational purposes and generally represents the size/capacity of unit to be provided by the Owner.

Utility requirements for equipment provided by Owner will be confirmed by the FSE Contractor and represented on the dimensioned rough-in plans for use by the construction trades.

ITEM #27 SPARE NO.

ITEM #28 SPARE NO.

ITEM #29 UNIVERSAL PAN RACK
Quantity: Two (2)
Manufacturer: Cres Cor
Model: 207-UA-13A

Rack, Mobile Utility, full height, open sides, (13) universal slides on 4-1/2" centers, multi-purpose, adjustable at 1-1/2" intervals, welded extruded aluminum frame, end loading, NSF

- Standard Warranty: 3 year parts, 1-year labor warranty, lifetime guarantee against rust & corrosion
- Corner bumpers

ITEM #30 SHELVING UNIT
Quantity: Eight (8)
Manufacturer: Metro
Model: 5X567GX3

MetroMax i Shelving Unit, of size and shape shown on plan. (4) polymer posts 74" H, (5) open grid polymer shelves with Microban antimicrobial protection, 600 lb. capacity per shelf, antimicrobial protection, KD, NSF

ITEM #31 SPARE NO.

ITEM #32 WALK IN REFRIGERATION

Quantity: One (1)
Manufacturer: Norlake
Model: Finline

Unit to be a Refrigerator +35° F. of size and shape as shown on plan x 9' - 2" high. Wall and ceiling panels shall be 4" urethane, U.L.Flame Spread 25 insulation. Panels are without wooden structural members. Thru ceiling door electrical assembly as shown on detail E-1-4.

Provide one (1) lot removable closure panels with channels, the same finish as exterior panels to ceiling. (F.S.E. Contractor to verify ceiling height). Closure to be louvered for top mounted condensing units (define)

One (1) lot of trim strip, where required to close in wall gaps, of same finish as exterior panels to finished ceiling. (F.S.E. Contractor to verify height).

Unexposed exterior finish to be galvalume.

Unit must comply with the Jan. 1, 2009 Federal Energy Regulations.

Options:

- Floorless with flat bottom wall panels in recess. (2) 2" layers of Slab urethane insulation (R-28), vapor barrier and quarry tile w/ minimum 2" setting bed by General Contractor.
- .040 embossed aluminum white interior and exposed exterior.
- Hinged entrance door w/ 14" x 14" vision panel, Kason K-1094 automatic door closer, three (3) Kason polished chrome hinges with spring assists, and Kason #27C polished chrome handle, hinged as shown on plan. Hinged doors to be 36" wide x 84" high with third hinge.
- Approved Kason #157752 48" LED 2-bulb, low-temp light fixtures for ceiling and Kason #157750 LED light fixture at each door installed and wired by the Electrical Division per detail E-1-4.(See electrical plan for quantity and location of lights and switches)
- Modularm 75LC, recessed with thru ceiling door electrical as shown on detail E-1-4.
- 2-1/2" dial thermometer flush-mounted.
- IP-1 Inside Panic Alarm for use with Modularm 75LC installed on interior door frame.
- Vinyl rub rail one level on exposed exterior mounted to cap the top of the wainscot, including door and door frame kickplates
- 4" x 4" x height of walk-in (in two pieces) x 1/8" diamond plate corner guards at exposed corners. Bottom piece from top of coved base tile/ Protect-All to the rub rail and the top piece from the top of the rub rail to the exposed top of the ceiling.
- 1/8" aluminum diamond tread kick plate, 3'- 0" high on door exterior and up to the bottom frame of the view window on the door interior. Exterior and interior of door jambs to be 3' high. Do not use pop rivet fasteners. Use counter-sunk stainless steel phillips-head screws to secure treadplate.\Wainscot on exposed exterior, 1/8" aluminum diamond plate. Provide panels 36" high and field cut to align panels with top of kickplate on door and achieve tight joint w/ top of tile.

CLEVENGER FRABLE LAVALLEE INC. FIT & FINISH REQUIREMENT:

Fit & Finish: The top closure, side trim strips, 1/8" aluminum diamond plate wainscot, and the vinyl rub rail are all to be back-ordered by the Foodservice Equipment Contractor. Once the walk-in is constructed and the finish floor work completed, the Foodservice Equipment Contractor is required to measure accurately for these accessories per the CFL details shown on the submittal drawings. Tread plate panels are to be secured to walk-in with countersunk, stainless steel, phillips head screws. Also, the audio-visual alarm probe wire and the dial thermometer probe wire must be uncoiled, extended and fastened neatly to the walls with the attachment clips that are provided by the manufacturer.

Per Clevenger Frable LaVallee, Inc. specification requirement, the GC is to insure and the FSEC is to confirm that the floor slab in the walk-in footprint area meets an FF50 flatness and an FL40 levelness standard as defined by the American Concrete Institute prior to the walk-in being erected. This requirement is necessary to insure proper fit of modular insulated panels and achieve level/plumb end result.

ITEM #33 CONDENSING UNIT, AIR COOLED
Quantity: One (1)
Manufacturer: Nor-Lake
Model: MSMD012AC

F.S.E.C. to provide the necessary refrigeration lines required to operate and maintain the refrigeration system for Item 32, refrigerated compartment. Unit to be part of the remote refrigeration system for Item 34, Evaporator Coil.

- F.S.E.C. to coordinate with the electrical/ plumbing contractor to provide a complete and operable refrigeration system.
- Provide start-up, five (5) year compressor warranty and one (1) year refrigeration service contract.
- Division 26 to wire to safety disconnect switch.
- Provide indoor ambient package.
- Unit to be located above cooler.

ITEM #34 REFRIGERATION COIL, MED TEMP
Quantity: One (1)
Manufacturer: Nor-Lake
Model: E1MD0136A-TA2

Unit to be adequately sized to operate Item 32, Refrigerator Compartment @ +35° F. Electrical hook-up and interconnecting of system to be by the Electrical Contractor. Indirect waste line extended to floor sink (drain) by FSE Contractor. Refer to Specific Conditions 2.10 Cold Storage Rooms, P. Drain Lines.

ITEM #35 SPARE NO.

ITEM #36 DISHTABLE, CLEAN (FUTURE)
Quantity: One (1)
Manufacturer: LTI
Model: Custom Fabrication

Unit to be of size and shape as shown on plan x 34" high to drainboard level with 10" high splash per details C-1-1A Type "D" edge, C-1-1B backsplash and C-8-1. Left end splash as shown on plan.

Provide with the following:

- Open base type table, no undershelf.
- Front to back crossbracing only.

ITEM #37 DISHWASHER, DOOR TYPE (FUTURE)
Quantity: One (1)
Manufacturer: Hobart
Model: AM15-2

Dishwasher, door type, hot water/chemical sanitizing, 58-65 racks/hour, straight-thru or corner, solid-state controls with digital status, with booster heater, electric tank heat, PRV included, auto-fill, stainless steel tank, frame, doors & feet, 208-240/60/3, 5 kW (machine); 208-240/60/3, 5 kW (booster) ENERGY STAR

- Standard warranty - 1-Year parts, labor & travel time during normal working hours within the USA
- Single point electrical connect AM15 kit (field installation required) (3 phase booster machines only)
- Drain water tempering kit
- Installation of DWT kit only (NET)
- Peg rack
- Combination rack
- Water hammer arrestor kit, includes 3/4" brass pressure regulator valve

ITEM #38 SOILED DISHTABLE (FUTURE)
Quantity: One (1)
Manufacturer: LTI
Model: Custom Fabrication

Unit to be of size and shape as show on plan x 34" high to drainboard level with 10" high splash per details C-1-1A, Type "D" edge, C-1-1B backsplash and C-8-1. Right end splash as shown on plan. Provide with the following:

- Provide open base type table, no undershelf.
- Pre-rinse sink 20" x 20" x 7" deep with Type 1 waste and stainless steel rack guide per details C-8-5 and C-8-10.
- Provide front to back and rear crossrails
- Provide a pass-thru window of length as shown on plan constructed similar to detail C-8-15.
- Soiled dish drop ledge per detail C-8-3A.

ITEM #39 SHELF, WALL MOUNTED (FUTURE)
Quantity: One (1)
Manufacturer: LTI
Model: Custom Fabrication

Unit to be of size and shape as shown on plan per detail C-1-2 with the following requirements:

- Two tier unit.
- Two-tier unit, first tier (lower shelf) to be 12" wide, second tier (upper) to be 15" wide.

ITEM #40 CONDENSATE HOOD (FUTURE)
Quantity: One (1)
Manufacturer: Captive-Aire
Model: 4824VHB-G-ND

Vapor Hood with full perimeter gutter. Unit to be of size and shape as shown on plan x 24" high. One (1) lot stainless steel enclosure paneling, at all open sides, to finished ceiling (F.S.E. Contractor to verify height). Paneling must be supplied by Exhaust Hood Manufacturer and installed by F.S.E. Contractor. Adhere to Specific Conditions for installation of fabricated equipment.

Ventilator to conform with NSF Standard #2, be in full conformance with the International Mechanical Code and all applicable state/local codes/ordinances.

F.S.E. Contractor to supply the necessary mounting rods for hanging ventilator.

Exhaust air requirements as shown on plans.

Exhaust riser factory installed.

Options:

- Sliding balancing damper.
- 304 S/S 100% Applicable
- Refer to preliminary drawing #4898410

FSE Contractor is responsible for fit of equipment. Prior to releasing hoods for fabrication, FSE Contractor needs to verify field conditions (existing &/or proposed) and to determine clearances to all structural items, obstructions, etc. The FSE Contractor will coordinate with other trades to confirm that the hood can be mounted as proposed and that the ductwork and final connection can be accommodated without conflict. Failure to perform this step may result in modifications to the exhaust hood at the FSE Contractor's

ITEM #41 SPARE NO.

ITEM #42 SPARE NO.

ITEM #43 WALK IN FREEZER
Quantity: One (1)
Manufacturer: Norlake
Model: Finline

Unit to be a Freezer -10° F. of size and shape as shown on plan x 8' – 7 5/8" high. Wall and ceiling panels shall be 4" urethane, U.L. Flame Spread 25 insulation. Panels are without wooden structural members.

Thru ceiling door electrical assembly as shown on detail E-1-4.

Provide one (1) lot removable closure panels with channels, the same finish as exterior panels to ceiling. (F.S.E. Contractor to verify ceiling height).

Closure to be louvered for top mounted condensing units.

One (1) lot of trim strip, where required to close in wall gaps, of same finish as exterior panels to finished ceiling. (F.S.E. Contractor to verify height).

Unexposed exterior finish to be galvalume.

Unit must comply with the Jan. 1, 2009 Federal Energy Regulations.

Options:

- 4" structural floor w/ built-in structural grid, 3/4" marine plywood. Built-in interior ramp.
- Hinged entrance door w/ 14" x 14" vision panel, Kason K-1094 automatic door closer, three (3) Kason polished chrome hinges with spring assists, and Kason #27C polished chrome handle, hinged as shown on plan. Hinged doors to be 36" wide x 84" high with third hinge.
- Approved Kason #157752 48" LED 2-bulb, low-temp light fixtures for ceiling and Kason #157750 LED light fixture at each door installed and wired by the Electrical Division per detail E-1-4.(See electrical plan for quantity and location of lights and switches)
- Modularm 75LC, recessed with thru ceiling door electrical as shown on detail E-1-4.
- 2-1/2" dial thermometer flush-mounted.
- IP-1 Inside Panic Alarm for use with Modularm 75LC installed on interior door frame.
- Vinyl rub rail one level on exposed exterior mounted to cap the top of the wainscot, including door and door frame kickplates
- Titan Thermoplastic Safety Flooring w/ plywood substrate per manufacturer's recommendations on insulated panel floor w/ 6" high coved base at interior perimeter. Color selected by Architect. Factory authorized installation by HCH-HPF Flooring, Inc. (Phone: 973-300-4551)
- 1/8" aluminum diamond tread kick plate, 3'- 0" high on door exterior and up to the bottom frame of the view window on the door interior. Exterior and interior of door jambs to be 3' high. Do not use pop rivet fasteners. Use counter-sunk stainless steel phillips-head screws to secure treadplate.
- Wainscot on exposed exterior, 1/8" aluminum diamond plate. Provide panels 36" high and field cut to align panels with top of kickplate on door and achieve tight joint w/ top of tile.

CLEVENGER FRABLE LAVALLEE INC. FIT & FINISH REQUIREMENT:

Fit & Finish: The top closure, side trim strips, 1/8" aluminum diamond plate wainscot, and the vinyl rub rail are all to be back-ordered by the Foodservice Equipment Contractor. Once the walk-in is constructed and the finish floor work completed, the Foodservice Equipment Contractor is required to measure accurately for these accessories per the CFL details shown on the submittal drawings. Tread plate panels are to be secured to walk-in with countersunk, stainless steel, phillips head screws. Also, the audio-visual alarm probe wire and the dial thermometer probe wire must be uncoiled, extended and fastened neatly to the walls with the attachment clips that are provided by the manufacturer.

Per Clevenger Frable LaVallee, Inc. specification requirement, the GC is to insure and the FSEC is to confirm that the floor slab in the walk-in footprint area meets an FF50 flatness and an FL40 levelness standard as defined by the American Concrete Institute prior to the walk-in being erected. This requirement is necessary to insure proper fit of modular insulated panels and achieve level/plumb end result.

ITEM #44 CONDENSING UNIT, AIR COOLED
Quantity: One (1)
Manufacturer: Nor-Lake
Model: MSLD020AC

F.S.E.C. to provide the necessary refrigeration lines required to operate and maintain the refrigeration system for Item 43, Freezer Compartment. Unit to be part of the remote refrigeration system for Item 45, Evaporator Coil.

F.S.E.C. to coordinate with the electrical/ plumbing contractor to provide a complete and operable refrigeration system.

Provide start-up, five (5) year compressor warranty and one (1) year refrigeration service contract. Division 26 to wire to safety disconnect switch.

- Provide indoor ambient package.
- Unit to be located above walk-in
- Loose timeclock (freezer only) installed above walk-in freezer.
- Condensing unit w/ protective cover.

ITEM #45 EVAPORATOR COIL, LOW TEMPERATURE
Quantity: One (1)
Manufacturer: Nor-Lake
Model: E1LD0076B-TE2

Unit to be adequately sized to operate Item 43, Freezer Compartment @ -10° F.

Electrical hook-up and interconnecting of system to be by the Electrical Contractor.

Heat tape for low temp coil drain line furnished and set-in-place by the FSE Contractor.

Final electrical connection to heat tape by Electrical Division.

Indirect waste line extended to floor sink (drain) by FSE Contractor. Refer to Specific Conditions 2.10 Cold Storage Rooms, P. Drain Lines.

ITEM #46 HAND SINK (FUTURE)
Quantity: One (1)
Manufacturer: Eagle Group
Model: HSAN-10-F

Hand Sink, wall mount, 9-3/4" x 13-1/2" x 6-3/4" deep bowl, splash mount gooseneck faucet, deep-drawn seamless design-positive drain, inverted "V" edge, 304 stainless steel construction, NSF.

4.5 FABRICATION DETAILS

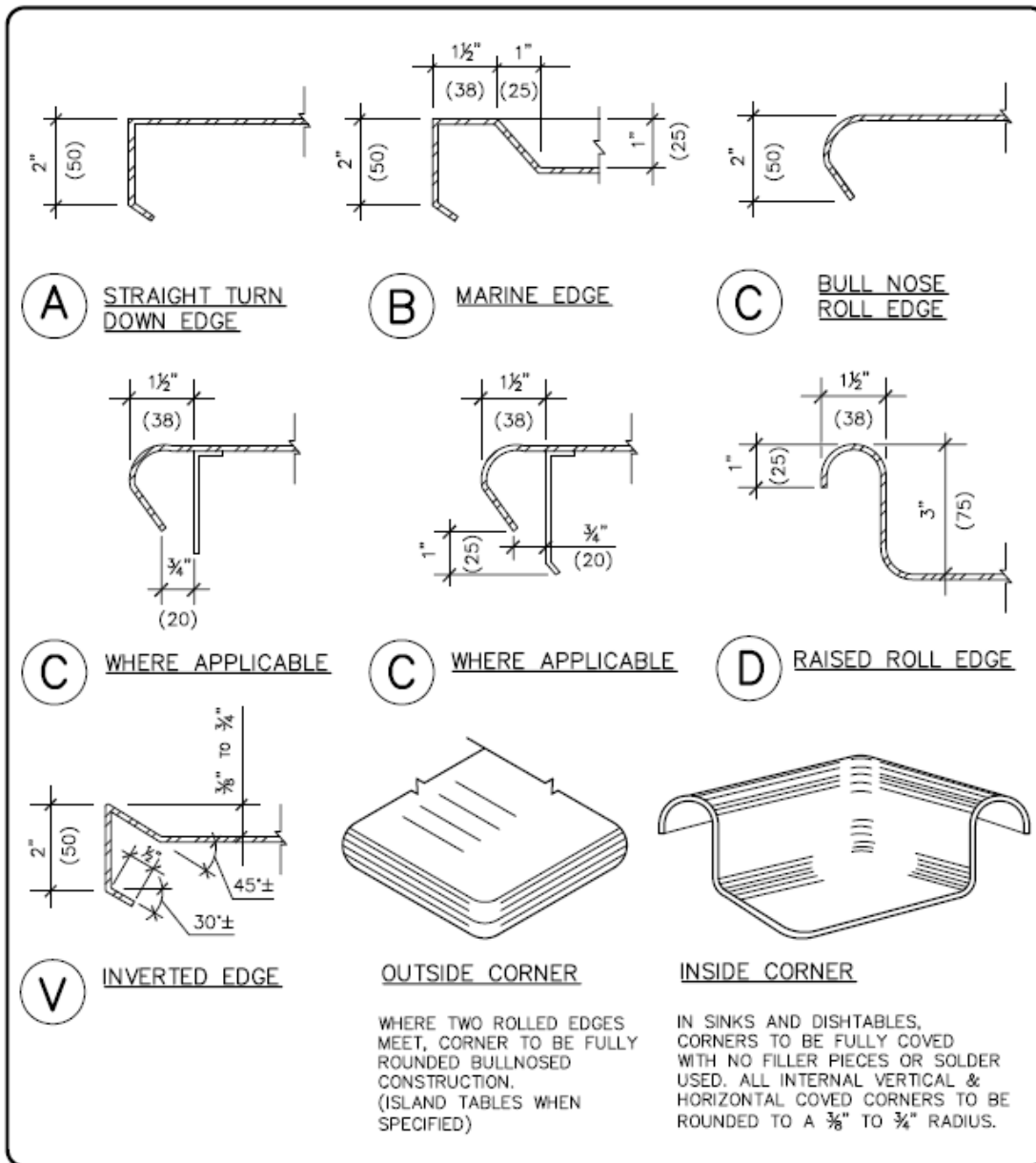

Clevenger Frable
 FOODSERVICE & LAUNDRY
 CONSULTING & DESIGN
LaVallee
 39 WESTMORELAND AVE., WHITE PLAINS, NY 10606
 TEL: 914/997-9660 FAX: 914/997-9671

EDGE DETAIL

05-07-12

C-1-1A

G:\XPDETS\FABRICATION DETAILS\C-1-1A

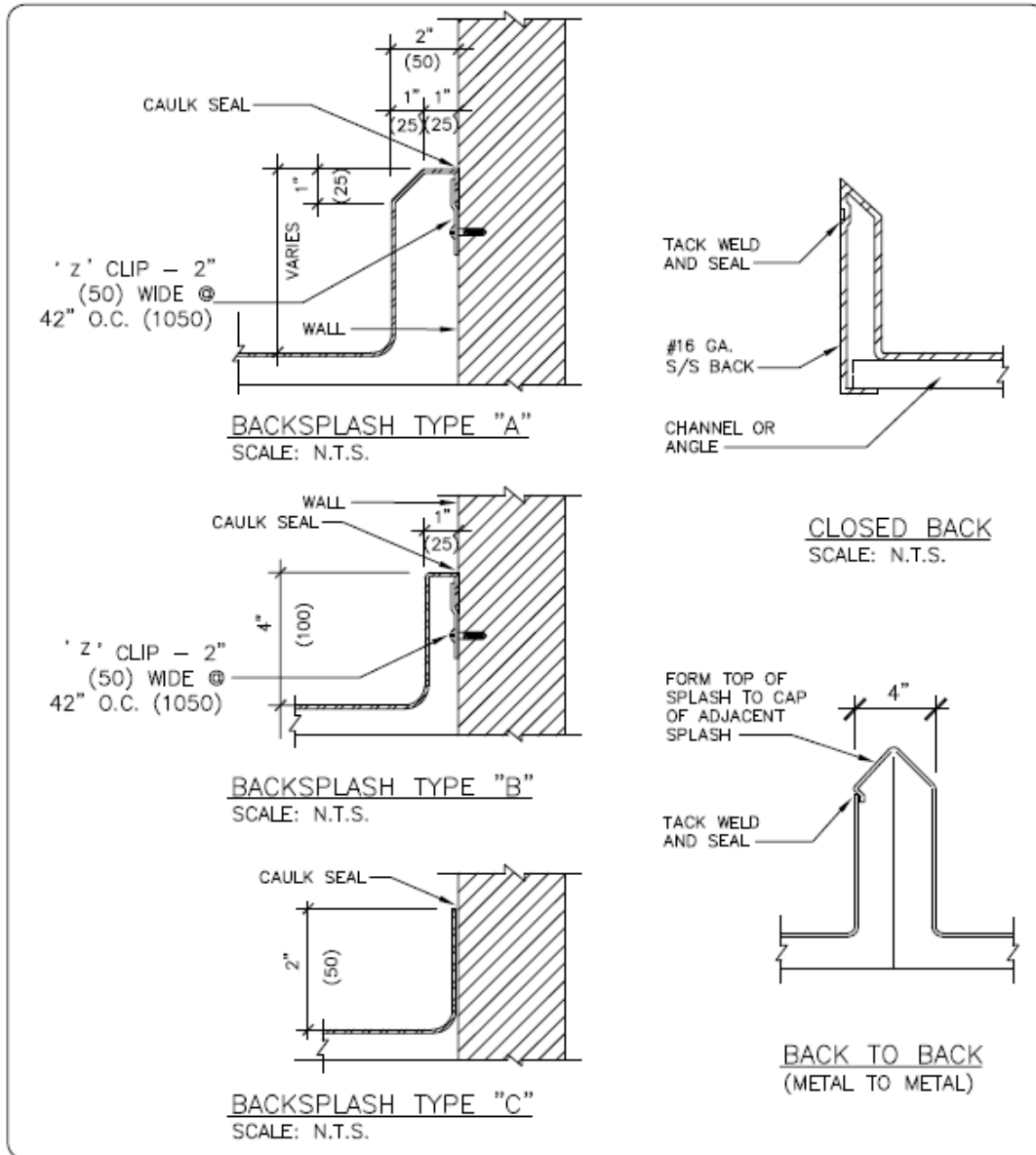

Clevenger Frable
 FOODSERVICE & LAUNDRY
 CONSULTING & DESIGN
LaVallee
 39 WESTMORELAND AVE., WHITE PLAINS, NY 10606
 TEL: 914/997-9660 FAX: 914/997-9671

BACK SPLASH DETAIL

05-08-12

C-1-B

G:\XPDETS\FABRICATION DETAILS\C-1-1B

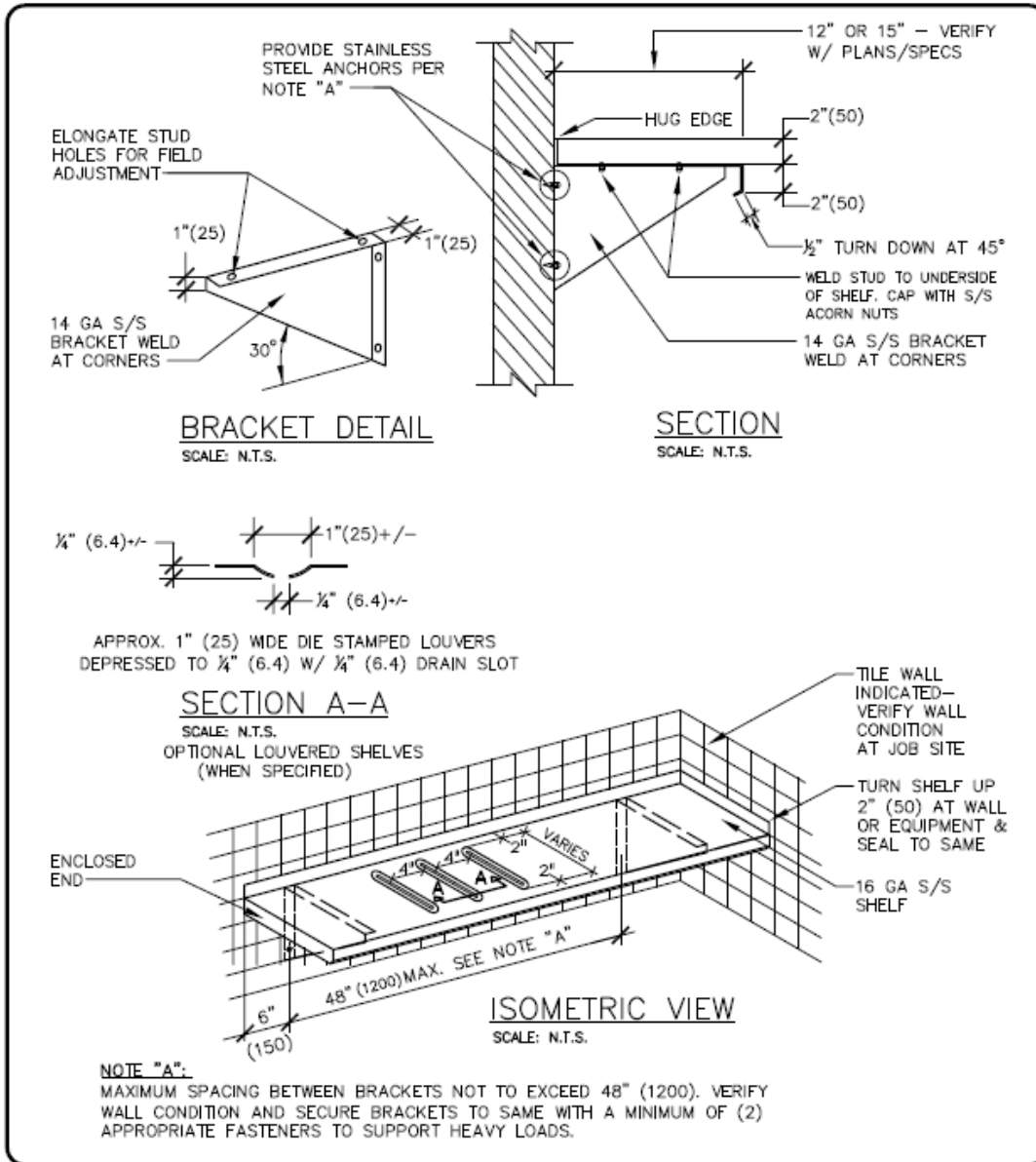

Clevenger Frable
 FOODSERVICE & LAUNDRY
 CONSULTING & DESIGN
 39 WESTMORELAND AVE., WHITE PLAINS, NY 10606
 TEL: 914/997-9660 FAX: 914/997-9671

EXPOSED BRACKET WALL
 MOUNTED OVERSHELF

07-12-13

C-1-2

G:\XPDETS\FABRICATION DETAILS\C-1-2

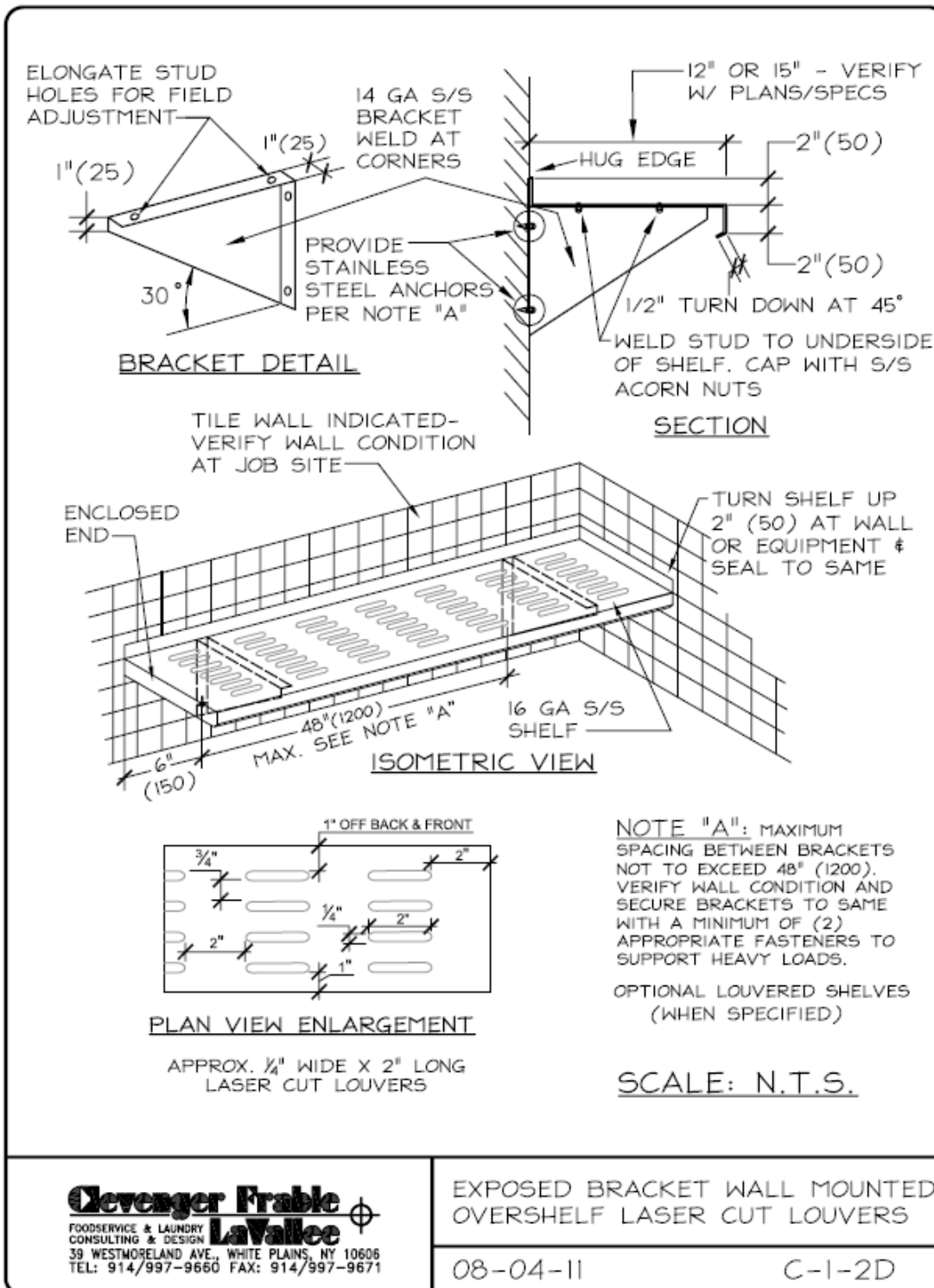

G:\KPDSETS\FABRICATION DETAILS\C-1-2D

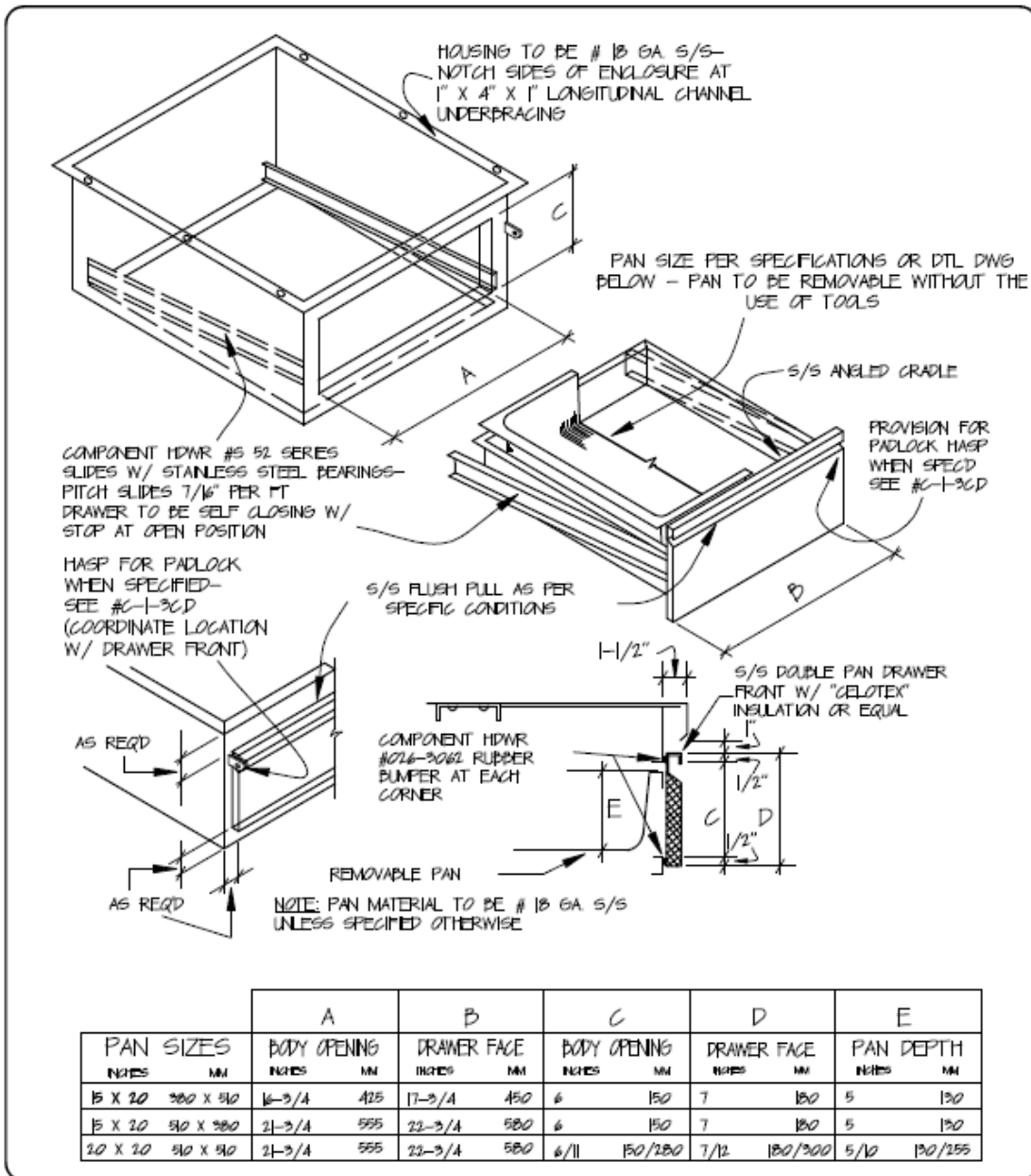

PAN SIZES INCHES	A		B		C		D		E			
	INCHES	MM	INCHES	MM	INCHES	MM	INCHES	MM	INCHES	MM		
15 X 20	380	910	16-3/4	425	17-3/4	450	6	150	7	180	5	130
15 X 20	340	880	21-3/4	555	22-3/4	580	6	150	7	180	5	130
20 X 20	340	940	21-3/4	555	22-3/4	580	6/11	150/280	7/12	180/300	5/10	130/255

Clevenger Frable
LaVallee
 FOODSERVICE & LAUNDRY
 CONSULTING & DESIGN
 39 WESTMORELAND AVE., WHITE PLAINS, NY 10606
 TEL: 914/997-9660 FAX: 914/997-9671

STANDARD DRAWER DETAIL
 REMOVABLE PAN TYPE

6/09

C-1-3A

© 2009 CLEVENGER FRABLE LAVALLEE

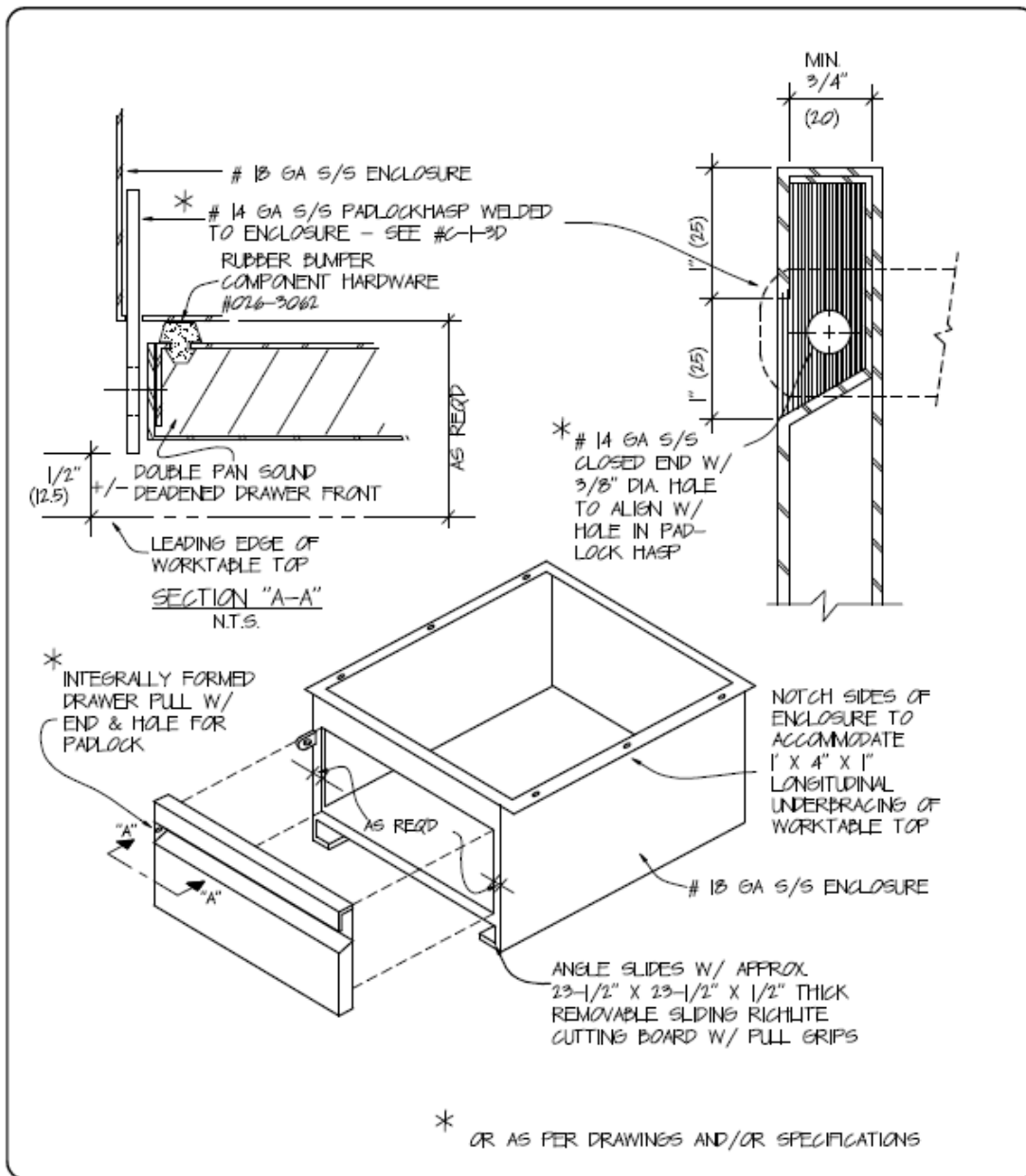

Cleaver Frable 
LaVallee
 FOODSERVICE & LAUNDRY CONSULTING & DESIGN
 39 WESTMORELAND AVE., WHITE PLAINS, NY 10606
 TEL: 914/997-9660 FAX: 914/997-9671

DOOR/DRAWER PULL
 DOOR FRONT

6/09

C-1-30

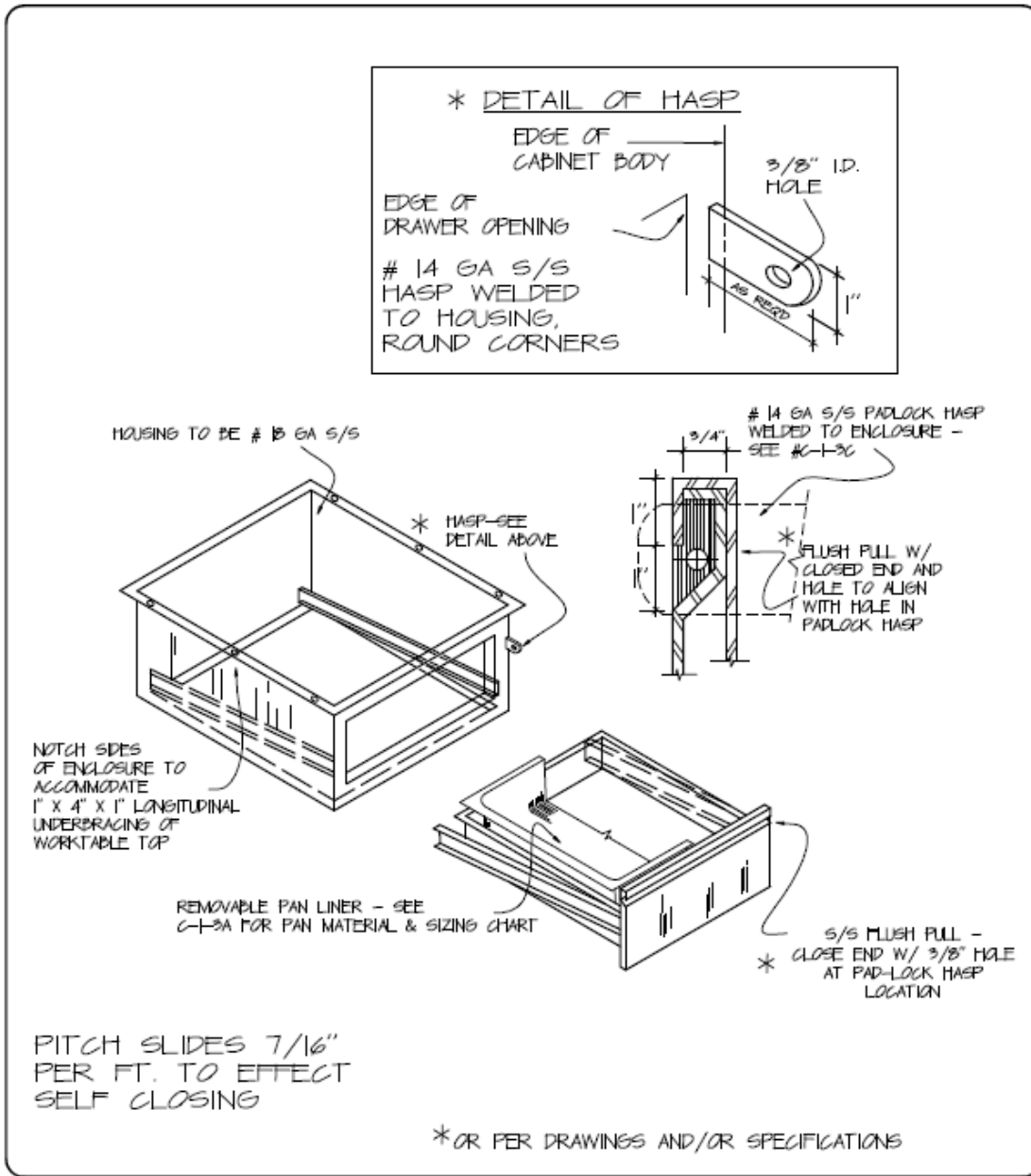

Clevenger Frable 
LaVallee
 FOODSERVICE & LAUNDRY
 CONSULTING & DESIGN
 39 WESTMORELAND AVE., WHITE PLAINS, NY 10606
 TEL: 914/997-9660 FAX: 914/997-9671

DRAWER PADLOCK
 HASP DETAIL
 (VFY PADLOCK REQ W/
 SPEC'S)

7/09

C-1-3D

QUALITY FABRICATION DELIVERED

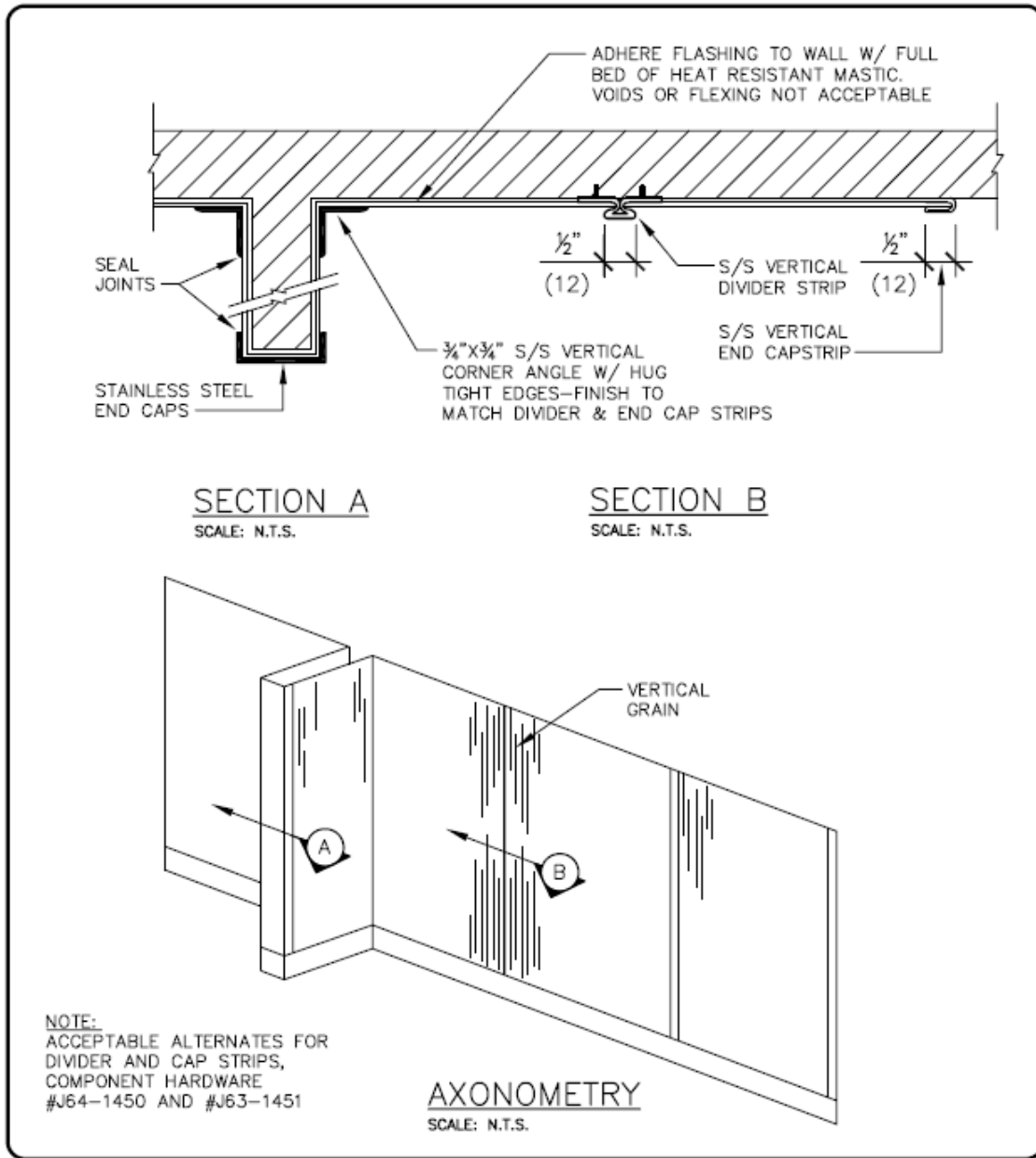

Clevenger Frable 
 FOODSERVICE & LAUNDRY CONSULTING & DESIGN
LaVallee
 39 WESTMORELAND AVE., WHITE PLAINS, NY 10606
 TEL: 914/997-9660 FAX: 914/997-9671

WALL FLASHING DETAIL

11-23-12

C-2-11

G:\KPDETS\FABRICATION DETAILS\C-2-11

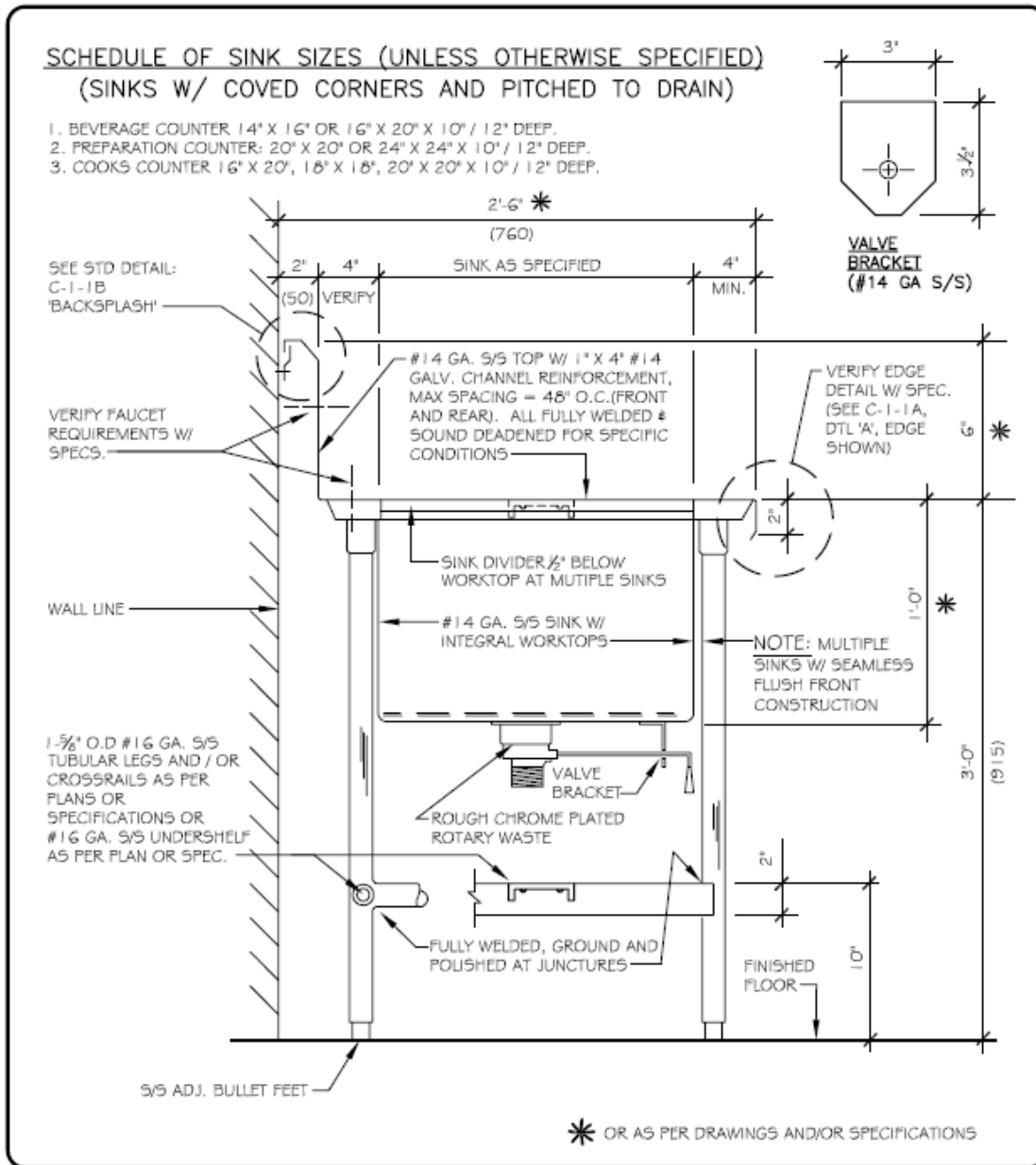

<p>Clevenger Frable FOODSERVICE & LAUNDRY CONSULTING & DESIGN LaVallee 39 WESTMORELAND AVE., WHITE PLAINS, NY 10606 TEL: 914/997-9660 FAX: 914/997-9671</p>	<p>TYPICAL WORKTABLE W/ SINKS</p> <p>12-12-11 C-7-1B</p>
--	--

G:\KPDETS\FABRICATION DETAILS\C-7-1B

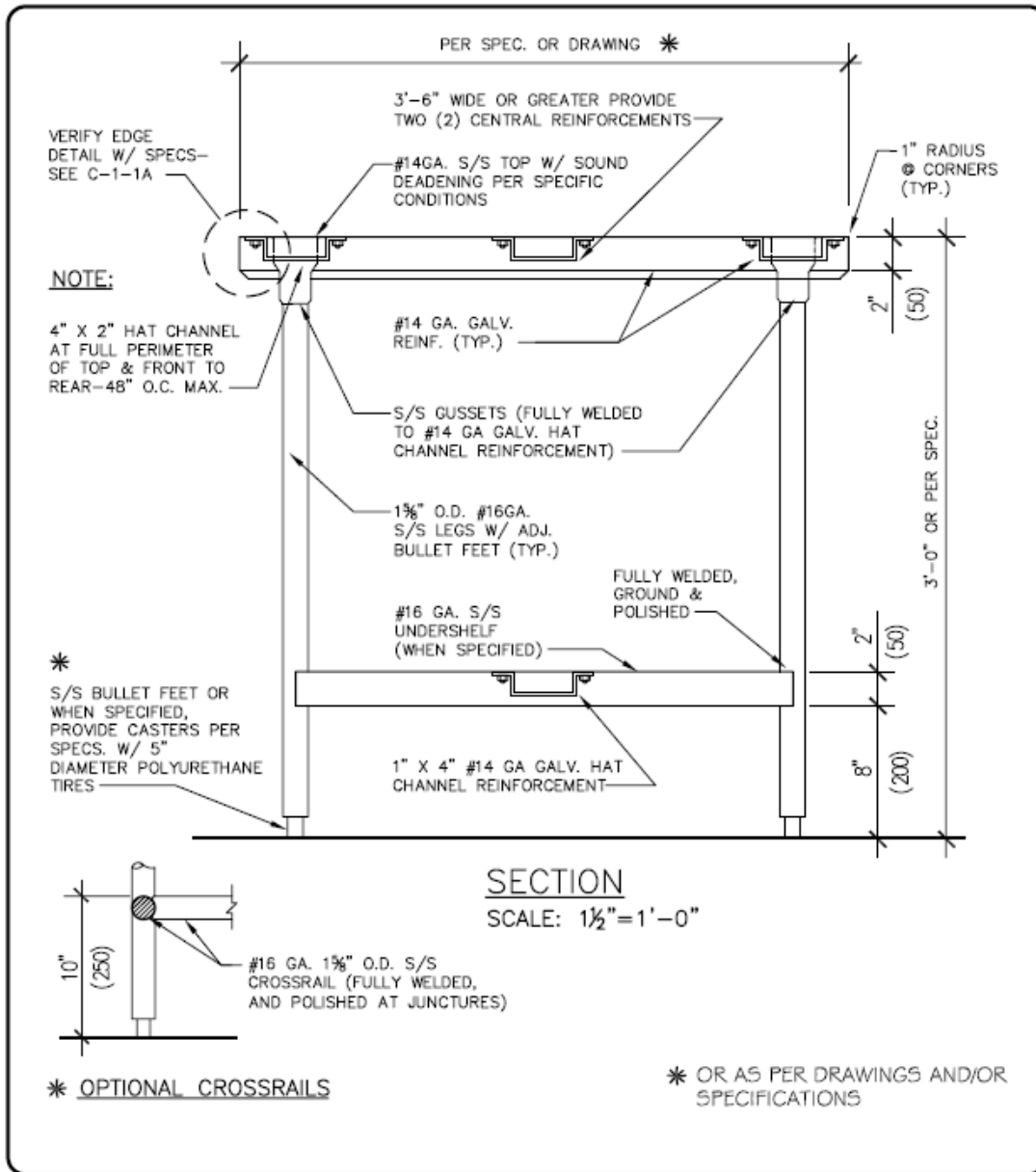

<p>Clevenger Frable FOODSERVICE & LAUNDRY CONSULTING & DESIGN LaVallee 39 WESTMORELAND AVE., WHITE PLAINS, NY 10606 TEL: 914/997-9660 FAX: 914/997-9671</p>	TYPICAL ISLAND TYPE WORKTABLE	
	12-12-11	C-7-1C

G:\KPDETS\FABRICATION DETAILS\C-7-1C

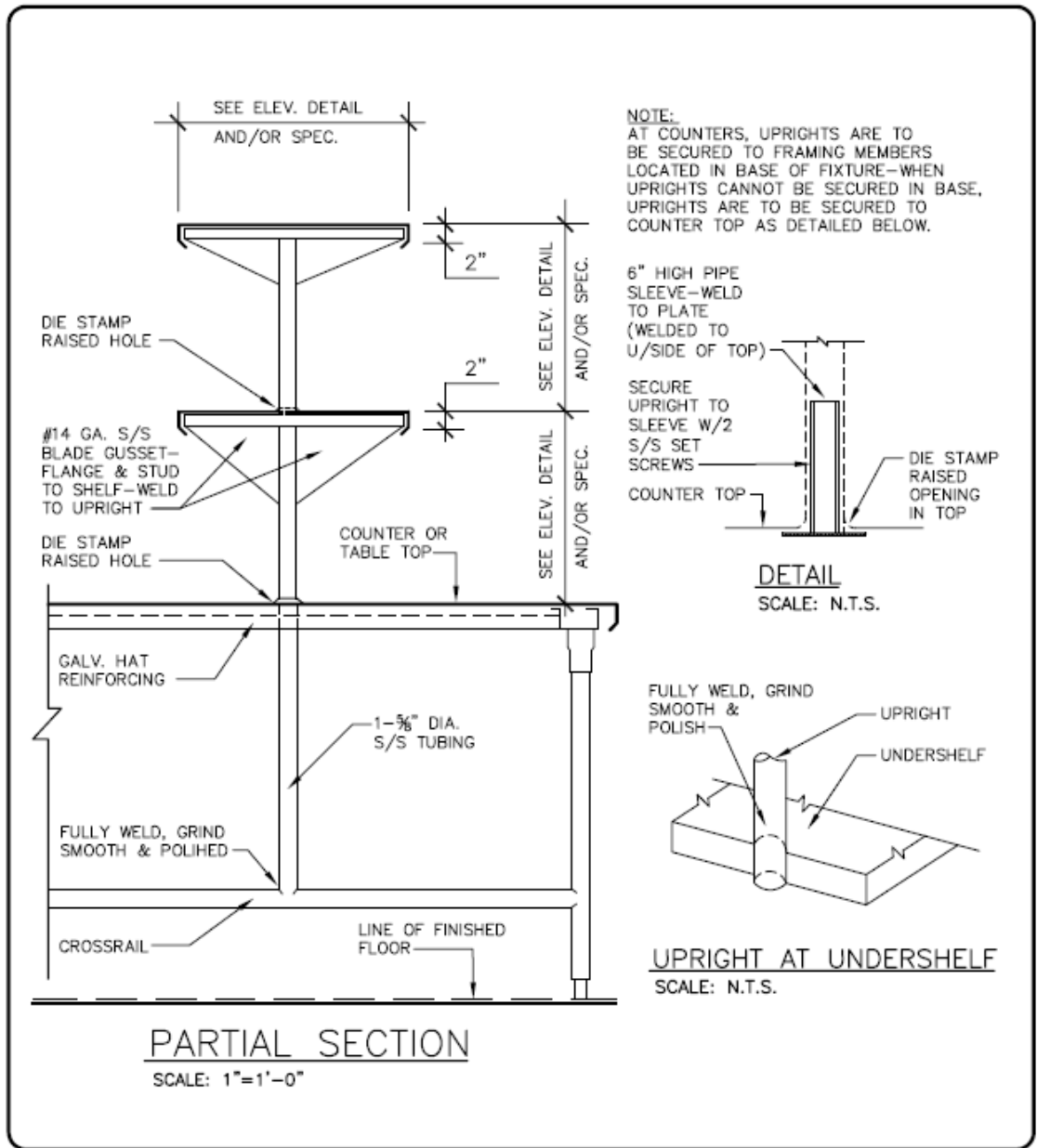

<p>Clevenger Frable  FOODSERVICE & LAUNDRY CONSULTING & DESIGN LaVallee 39 WESTMORELAND AVE., WHITE PLAINS, NY 10606 TEL: 914/997-9660 FAX: 914/997-9671</p>	<p>FIXED MOUNTED OVERSHELF(S)</p>	
	<p>06-07-12</p>	<p>C-7-8</p>

G:\KPDETS\FABRICATION DETAILS\C-7-8

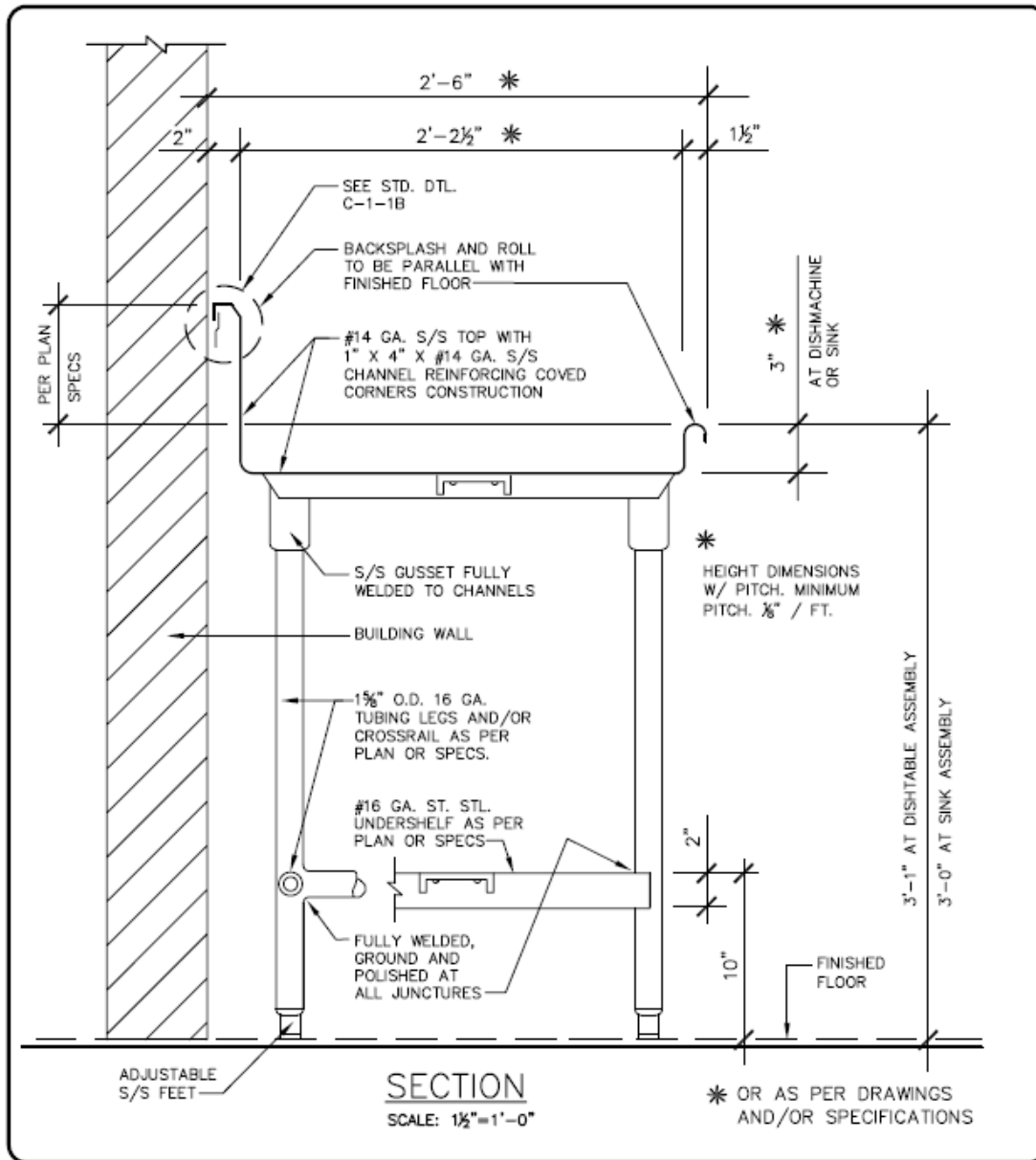

<p>Clevenger Frable FOODSERVICE & LAUNDRY CONSULTING & DESIGN LaVallee 39 WESTMORELAND AVE., WHITE PLAINS, NY 10606 TEL: 914/997-9660 FAX: 914/997-9671</p>	DISHTABLE-DRAINBOARD	
	05-16-12	C-8-1

G:\KPDETS\FABRICATION DETAILS\C-8-1

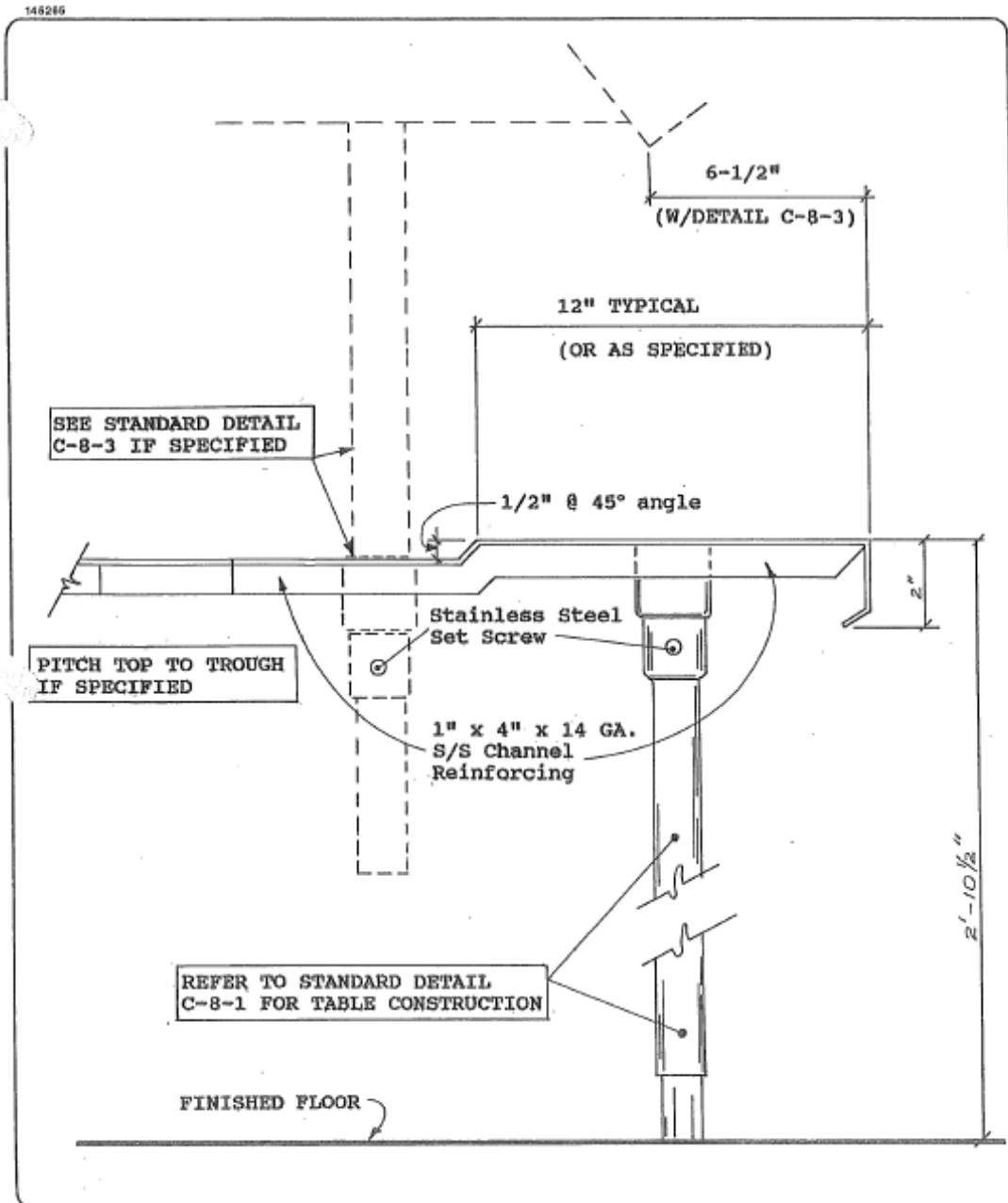

Clevenger Frable
FOODSERVICE & LAUNDRY
CONSULTING & DESIGN
LaVallee

SOILED DISH DROP LEDGE
DEC 90
C-8-3A

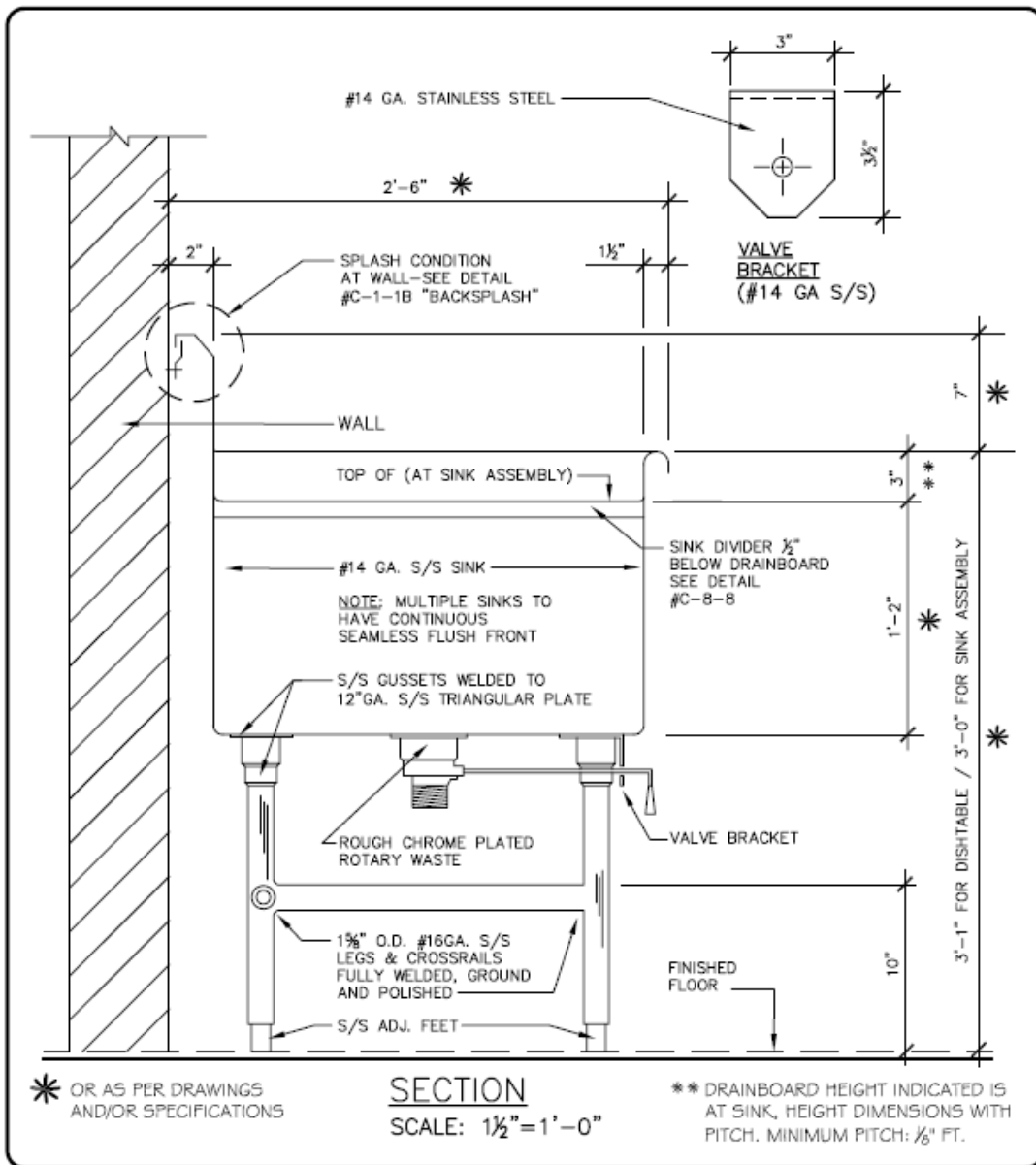

<p>Clevenger Frable FOODSERVICE & LAUNDRY CONSULTING & DESIGN 39 WESTMORELAND AVE., WHITE PLAINS, NY 10606 TEL: 914/997-9660 FAX: 914/997-9671</p>	SINK ASSEMBLY	
	05-21-12	C-8-5

G:\KPDETS\FABRICATION DETAILS\C-8-5

145265

SCRAP BASKETS: (2) # 16 GA. STAINLESS STEEL BASKETS, COVED CORNERS, HEM TOP 1". PERFORATE SIDES AND BOTTOM WITH 1/4" HOLES 5/8 O.C. WELD 1/2 DIA. 1" HIGH S/S ROD FEET IN PLACE

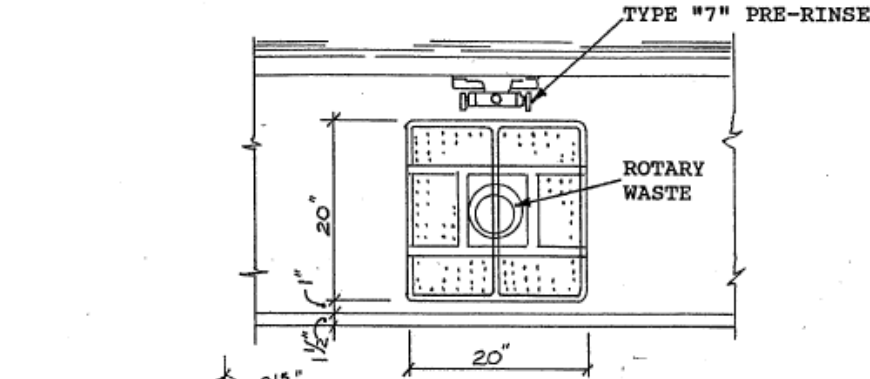

PLAN VIEW

NOTE:
 FOR DISPOSER APPLICATION,
 DELETE ROTARY WASTE AND
 VALVE BRACKET AND SCRAP
 BASKETS - WELD IN
 ADAPTOR COLLAR AND
 INSTALL DISPOSER AS PER
 MANUFACTURER'S SPEC.

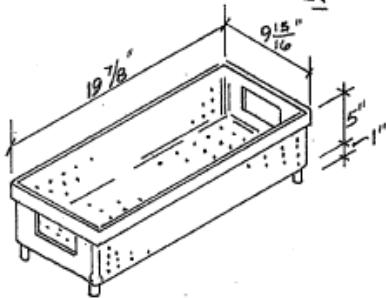

1" X 3/4" 14 GA. S/S
 CHANNEL FRAME. FRAME
 TO SET FLUSH W/DISHTABLE.

PROVISION FOR WATER
 INLET WHEN DISPOSER
 IS SPECIFIED

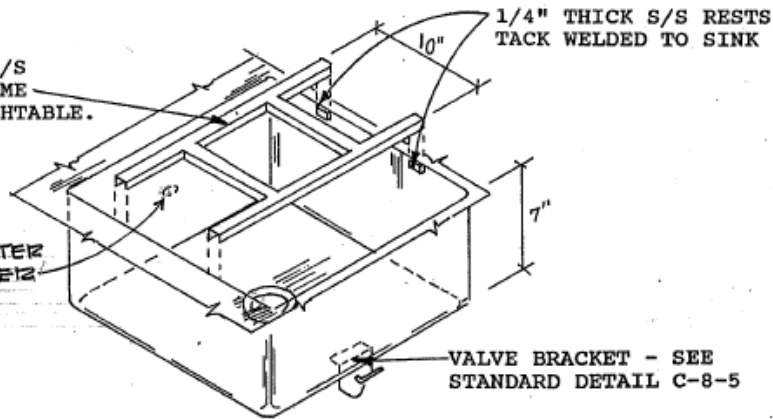

ISOMETRIC

Clevenger Frable
 FOODSERVICE & LAUNDRY
 CONSULTING & DESIGN **LaVallee**

**PRE-RINSE SINK & REMOVABLE
 RACK GUIDE DETAIL**

DECEMBER 2016

C-8-10

UNITED REPROGRAPHICS

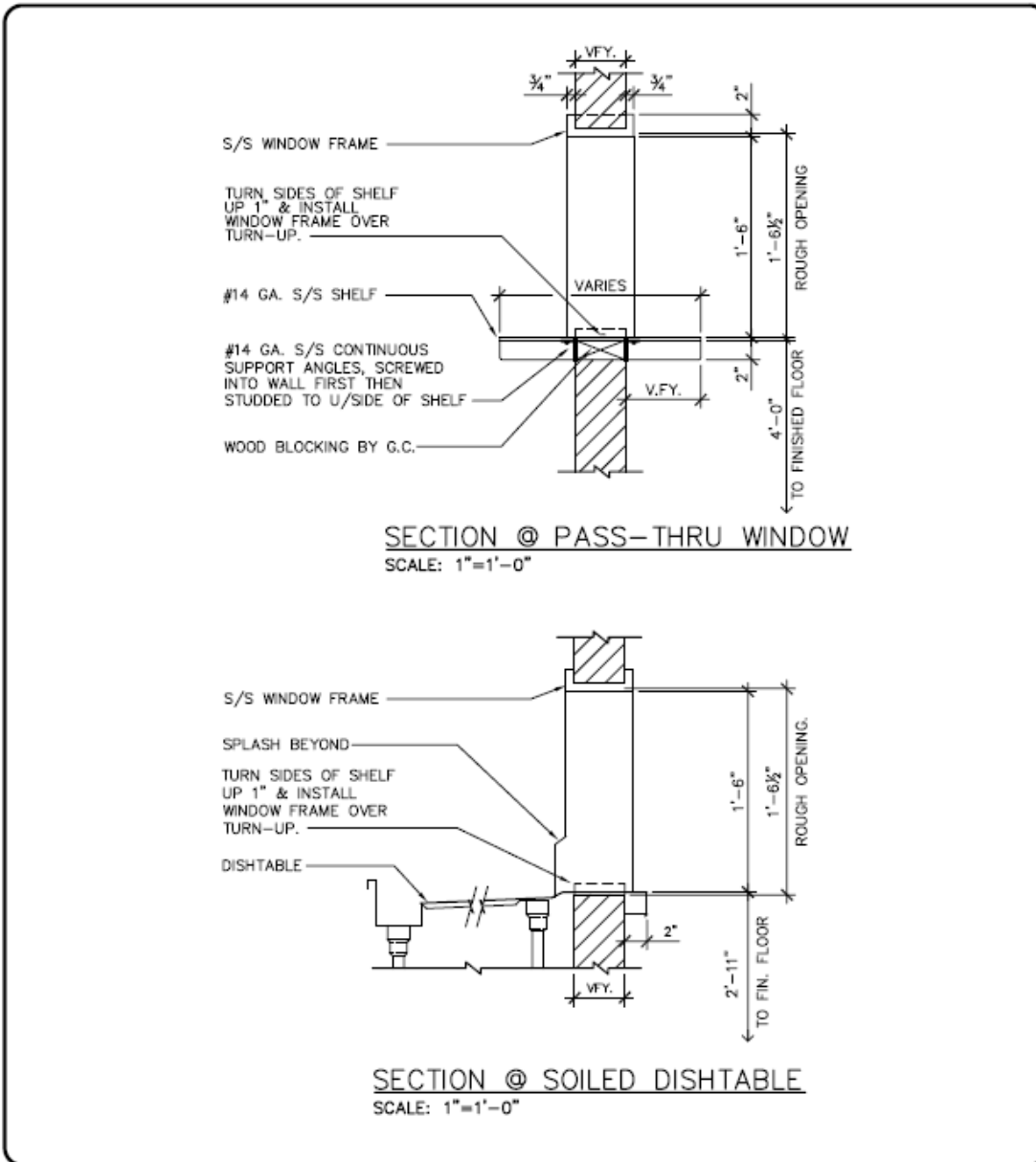

<p>Clevenger Frable  FOODSERVICE & LAUNDRY CONSULTING & DESIGN 39 WESTMORELAND AVE., WHITE PLAINS, NY 10606 TEL: 914/997-9660 FAX: 914/997-9671</p>	<p>PASS-THRU WINDOW DETAILS</p>	
	<p>05-23-12</p>	<p>C-8-15</p>

G:\KPDETS\FABRICATION DETAILS\C-8-15

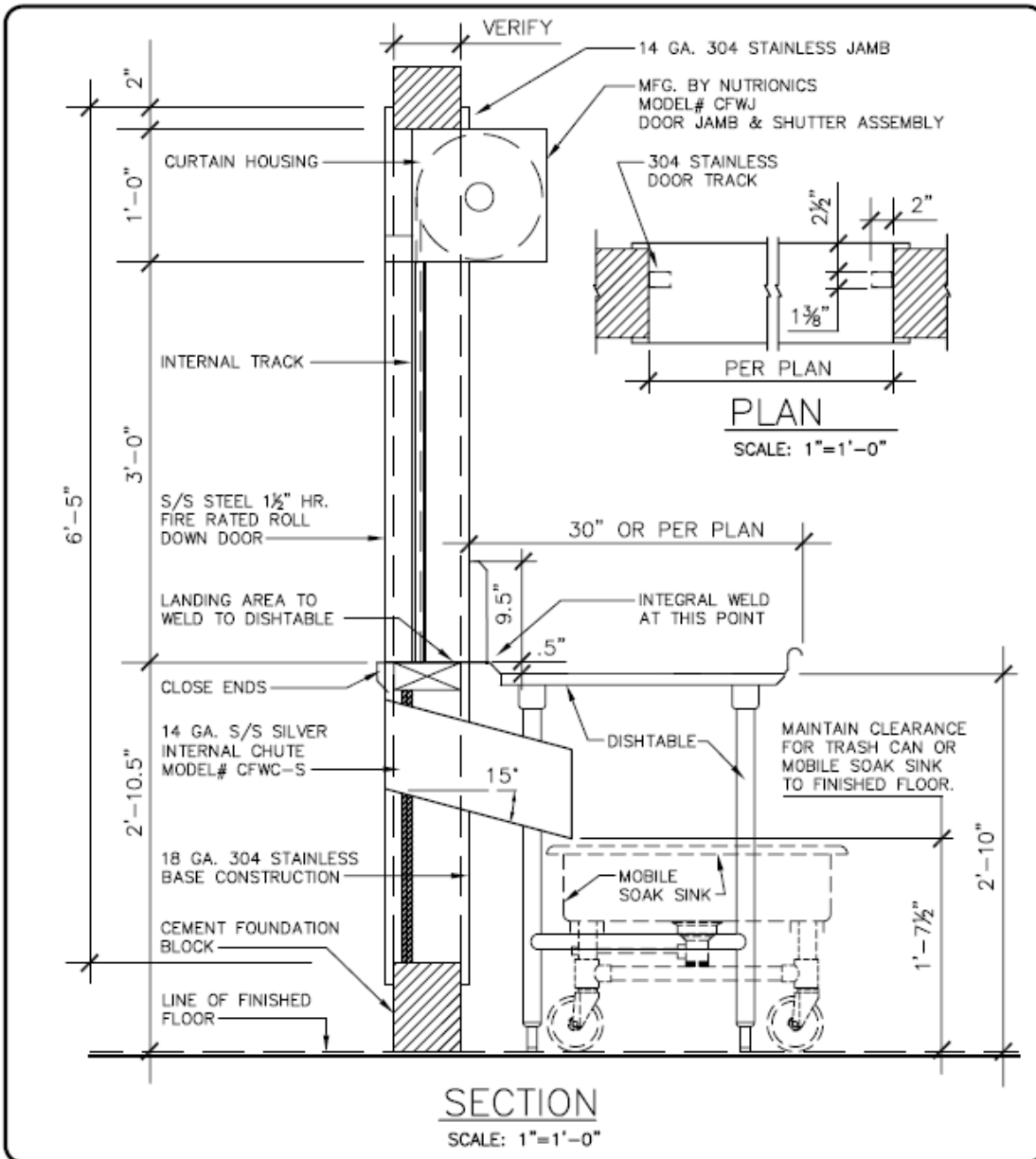

Clevenger Frable
 FOODSERVICE & LAUNDRY
 CONSULTING & DESIGN
LaVallee
 39 WESTMORELAND AVE., WHITE PLAINS, NY 10606
 TEL: 914/997-9660 FAX: 914/997-9671

PRE-FABRICATED DOOR
 JAMB ASSEMBLY & ROLL
 DOWN SHUTTER

08-08-11 C-8-15B

G:\KPDETS\FABRICATION DETAILS\C-8-15B

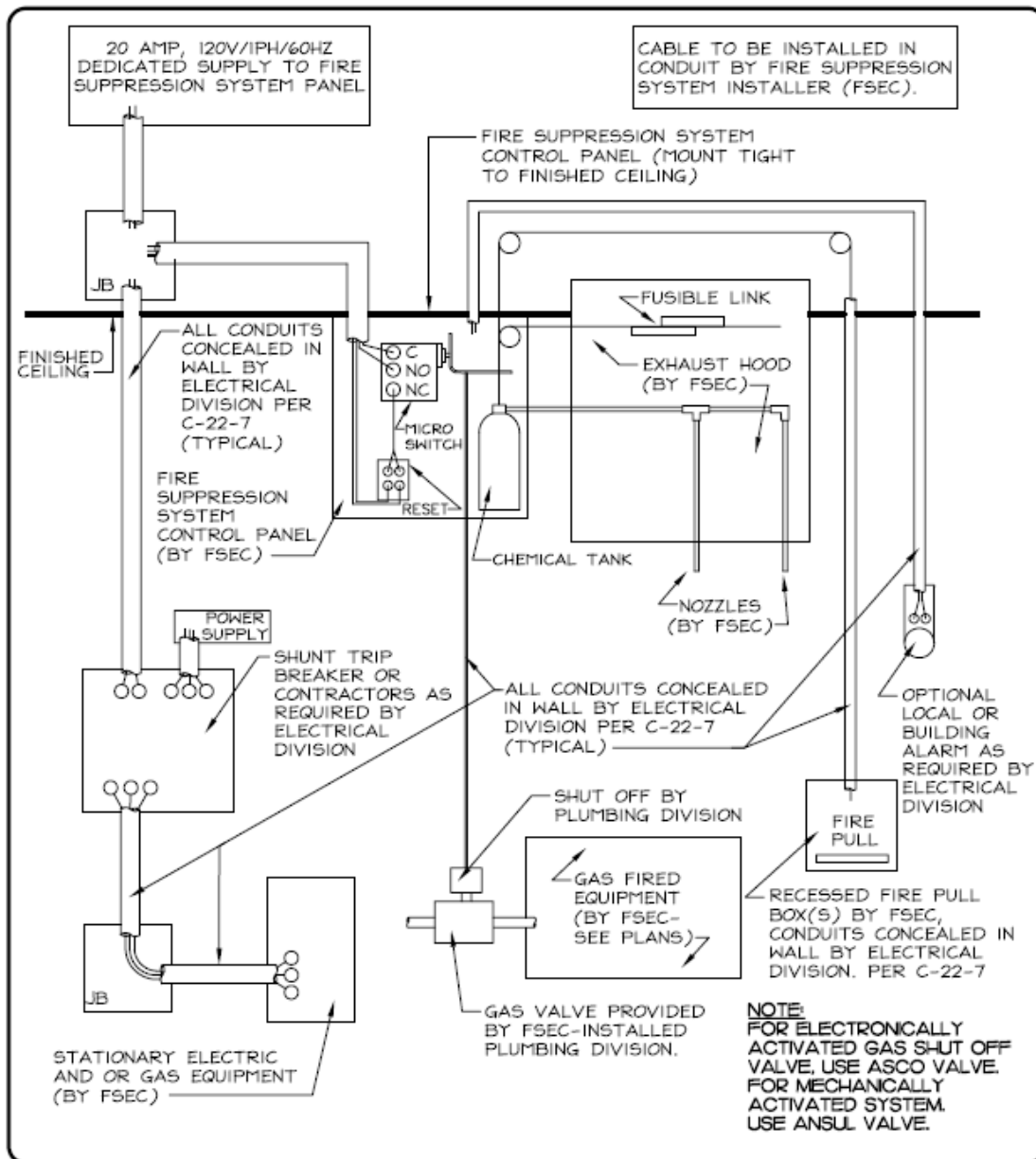

Clevenger Frable
 FOODSERVICE & LAUNDRY CONSULTING & DESIGN
LaVallee
 39 WESTMORELAND AVE., WHITE PLAINS, NY 10606
 TEL: 914/997-9660 FAX: 914/997-9671

TYPICAL
 FIRE SUPPRESSION
 SYSTEM

05-08-12

C-22-6

G:\KPDETS\BUILDING WORKS\C-22-6

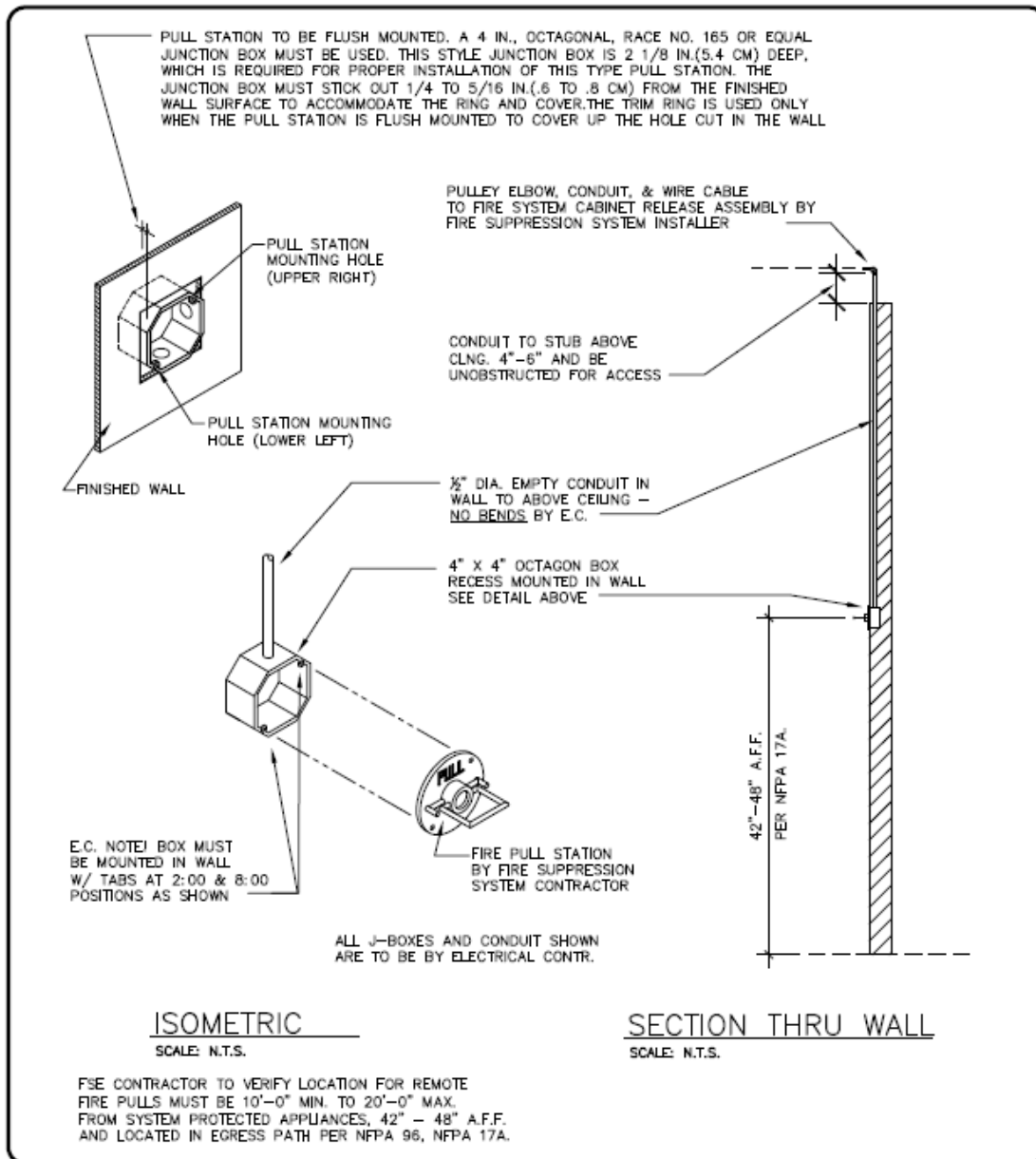

<p>Clevenger Frable FOODSERVICE & LAUNDRY CONSULTING & DESIGN LaVallee 39 WESTMORELAND AVE., WHITE PLAINS, NY 10606 TEL: 914/997-9660 FAX: 914/997-9671</p>	<p>FIRE SYSTEM REMOTE PULL DETAIL (CONDUIT CONCEALED TO ABOVE CEILING)</p> <p>06-06-12 C-22-7</p>
---	--

G:\KPDETS\BLDCWKS\C-22-7

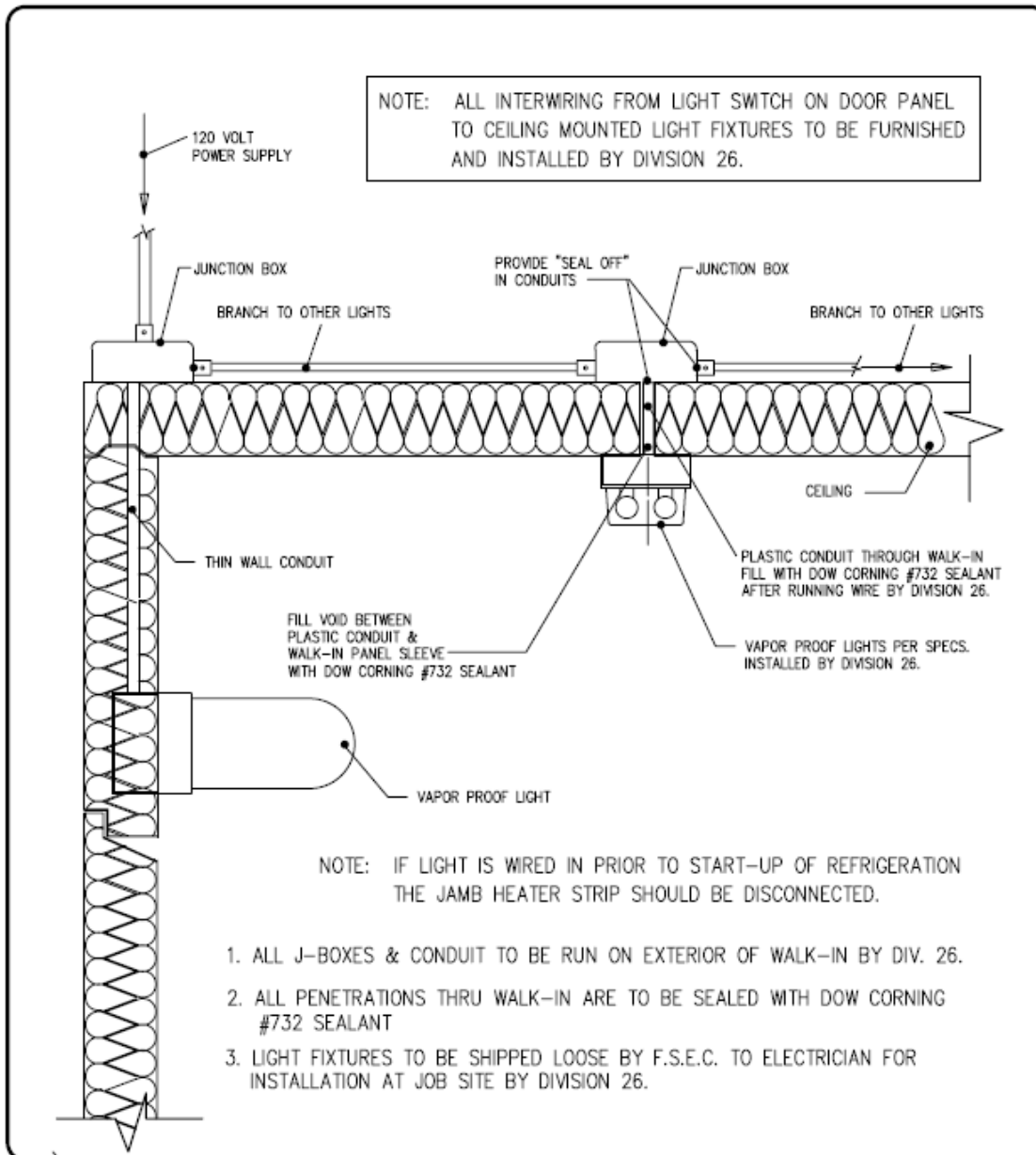

<p>Clevenger Frable </p> <p>FOODSERVICE & LAUNDRY CONSULTING & DESIGN LaVallee</p> <p>39 WESTMORELAND AVE., WHITE PLAINS, NY 10606 TEL: 914/997-9660 FAX: 914/997-9671</p>	<p>WALK-IN REFRIGERATOR LIGHT INSTALLATION</p>	
	<p>02-16-12</p>	<p>E-1-4</p>

G: /KPDETS/CSR DETAILS/CAD FILES/E-1-4



Project Name _____

BROCHURE LEAD SHEET:

ITEM NO: _____ QUANTITY: _____
 DESCRIPTION: _____
 MANUFACTURER: _____
 MODEL NUMBER: _____
 DESCRIPTION: _____

UTILITIES:

ELECTRICAL

	VOLTS	CYCLE	PHASE	CONN	AFF	NEMA	AMPS	KW	HP	MCA	MOCP
1											

GAS

	SIZE	MBTU	KW
1			

STEAM

	INLET SIZE	RETURN SIZE	PISG (min)	PSIG (max)
1				

WATER

	HOT SIZE	HOT AFF	HOT GPH	COLD SIZE	COLD AFF	FILTERED SIZE	FILTERED AFF	CONDENSER INLET SIZE	CONDENSER OUTLET SIZE
1									

WASTE

	INDIRECT SIZE	DIRECT SIZE
1		

ACCESSORIES, ATTACHMENTS OR REMARKS:

1. _____
2. _____
3. _____
4. _____
5. _____
6. _____

Appendix A



**ALTERNATE **
SUBSTITUTION
REQUEST

Project: _____ Substitution Request Number: _____
From: _____
To: _____ Date: _____
CFL Project Number: _____
Re: _____ Contract For: _____

Specification Title: _____ Description: _____
Section: _____ Page: _____ Article/Paragraph: _____

Proposed Substitution: _____
Manufacturer: _____ Address: _____ Phone: _____
Trade Name: _____ Model No.: _____
Installer: _____ Address: _____ Phone: _____

History: New product 2-5 years old 5-10 yrs old More than 10 years old

Differences between proposed substitution and specified product: _____

Point-by-point comparative data attached - REQUIRED BY CFL

Reason for not providing specified item: _____

Similar Installation:
Project: _____ Architect: _____
Address: _____ Owner: _____
Date Installed: _____

Proposed substitution affects other parts of Work: No Yes; explain _____

Savings to Owner for accepting substitution: _____ (\$ _____).

Proposed substitution changes Contract Time: No Yes [Add] [Deduct] _____ days.

Supporting Data Attached: Drawings Product Data Samples Tests Reports _____

Appendix B		
------------	--	--

**ALTERNATE **
SUBSTITUTION

REQUEST
(Continued)

The Undersigned certifies:

- Proposed substitution has been fully investigated and determined to be equal or superior in all respects to specified product.
- Same warranty will be furnished for proposed substitution as for specified product.
- Same maintenance service and source of replacement parts, as applicable, is available.
- Proposed substitution will have no adverse effect on other trades and will not affect or delay progress schedule.
- Cost data as stated above is complete. Claims for additional costs related to accepted substitution which may subsequently become apparent are to be waived.
- Proposed substitution does not affect dimensions and functional clearances.
- Payment will be made for changes to building design, including A/E design, detailing, and construction costs caused by the substitution.
- Coordination, installation, and changes in the Work as necessary for accepted substitution will be complete in all respects.

Submitted by: _____

Signed by: _____

Firm: _____

Address: _____

Telephone: _____

Attachments: _____

CFL's REVIEW AND ACTION

- Substitution approved - Make submittal in accordance with 114000 Specifications Section 1.13 Submittal
- Substitution approved as noted - Make submittal in accordance with 114000 Specifications Section 1.13 Submittal
- Substitution rejected - Use specified materials.
- Substitution Request received too late - Use specified materials.

Signed by:

Date:

Additional Comments: Contractor Subcontractor Supplier Manufacturer CFL _____

Appendix B		
------------	--	--



Sample Itemized Bid Proposal Form:

Item #	Description & Accessories	Qty.	Sell	Sell Total
21	Food Slicer, Electric Globe Model No. 3600N	1 ea	\$3,271.00	\$3,271.00
	Globe Premium Slicer, 13" dia. steel alloy knife blade, manual, gear-driven knife system, start/stop touchpad controls, 2" angled drip groove on slicer table, knife ring guard with removable deflector, knife cover interlock and dual gear slice-thickness adjustment, 45: carriage angle, 12: food chute carriage, stainless steel construction, ½ HP, 115v/60/1=ph, 7.0 amps, NEMA 5-15P, cETLus, NSF/ANSI 8-2010, Made in USA			
	1 year labor warranty from date of original installation (not to exceed 18 months from factory shipment)	1 ea		
	2 year parts warranty (excludes wear/expendable parts) 15 year drive gears warranty (see Warranty sheet for complete details)	1 ea 1 ea		
NOTE:	This model does not include automatic shut off. The Globe 4600N includes an automatic shut off.			

Appendix C

SECTION 114900 - GYMNASIUM EQUIPMENT

PART 1 - GENERAL

1.1 SUMMARY

- A. This Section includes the following gymnasium equipment:
 - 1. Swing-down electric basketball backstops.
 - 2. Wall protection mats.
 - 3. Floor sleeves for badminton and volleyball equipment
- B. Related Sections: The following Sections contain requirements that relate to this Section:
 - 1. Division 26 Sections for conduit, wiring, junction boxes and components supplied and installed by the Electrical Contractor in connection with electric motors and electronic equipment for gymnasium equipment.

1.2 SUBMITTALS

- A. Product data for each type of gymnasium equipment, including manufacturer's specifications, assembly and installation instructions, and maintenance recommendations.
 - 1. Motors: Show nameplate data, ratings, characteristics, and mounting arrangements
- B. Shop drawings indicating layout of gymnasium equipment coordinated with field measurements, connections and relationship to adjoining work, accessories, types of materials, and finishes.
- C. Wiring diagrams from manufacturer for electrically operated equipment.
- D. Samples for initial selection purposes in form of manufacturer's color charts consisting of actual units or sections of units showing full range of colors and textures available for each exposed material involving such selections.
- E. Samples for verification in the form of 12-inch (300-mm) square pieces of wall protection mat fabric specified.
- F. Operating and maintenance data for inclusion in Operating and Maintenance Manual specified in Division 01 including detailed instructions indicating proper means for operating and maintaining each type of gymnasium equipment and accessory required.
- G. Qualification data for firms and persons specified in "Quality Assurance" Article to demonstrate their capabilities and experience. Include list of completed projects with project names, addresses, names of Architects and Owners, and other information specified.

1.3 QUALITY ASSURANCE

- A. Installer Qualifications: Engage an experienced Installer to perform unit of work of this section who has specialized in the installation of types of gymnasium equipment required for this project and who is acceptable to, or certified by, manufacturer of the equipment.
- B. Source Quality Control: Provide each type of gymnasium equipment and related accessories by a single manufacturer.
- C. Electrical Components, Devices, and Accessories: Listed and labeled as defined in NFPA 70, Article 100, by a testing agency acceptable to authorities having jurisdiction, and marked for intended use.

1.4 PROJECT CONDITIONS

- A. Field Measurements: Check actual dimensions of construction affecting gymnasium equipment by accurate field measurements before fabrication; show recorded measurements on final shop drawings. Coordinate fabrication schedule with construction progress to avoid delay of Work.
 - 1. Where field measurements cannot be made without delaying the Work, guarantee dimensions and proceed with fabrication of equipment without field measurements.

1.5 WARRANTY

- A. General: Warranties specified in this Article shall not deprive the Owner of other rights the Owner may have under other provisions of the Contract Documents and will be in addition to and run concurrent with other warranties made by the Contractor under requirements of the Contract Documents.
- B. Warranty: Submit a written warranty, executed by the manufacturer, agreeing to repair or replace gymnasium equipment that fails in materials or workmanship within the specified warranty period as follows:
 - 1. Glass backboards: Lifetime warranty against breakage.
 - 2. Bolt-on safety padding: 8 year warranty.

PART 2 - PRODUCTS

2.1 MANUFACTURERS

- A. Available Manufacturers: Subject to compliance with requirements, manufacturers offering gymnasium equipment which may be incorporated in the work include, but are not limited to, the following:
 - 1. Draper Inc.
 - 2. Jaypro Sports, LLC.
 - 3. Porter Athletic Equipment Company.

4. Schelde North America.

2.2 MATERIALS

- A. Steel Pipe and Plate: Manufacturer's standard heavy-walled steel pipe and plate, zinc plated.
- B. Extruded Aluminum: ASTM B 221, alloy 6063-T6
- C. Aluminum Sheet: Alloy and temper recommended by manufacturer for use intended and as required for proper application of finish indicated but with not less than the strength and durability properties specified in ASTM B 209 for 5005-H15.
- D. Backboard Material: Clear tempered glass, 1/2" thick, meeting ASTM C 1048, Condition A (uncoated surfaces), Type I (transparent glass, flat), Class 1 (clear), Quality q3 (glazing select), Kind FT (fully tempered).
- E. Fasteners: Manufacturer's standard non-corroding through-connection type; screws are not acceptable.

2.3 CEILING SUPPORTED BASKETBALL BACKSTOP AND ACCESSORIES

- A. Backstop: Ceiling supported, forward-folding basketball backstop consisting of the frame, front brace, key-operated winch and cabling, rectangular banks/padding, safety lock and all necessary support framing and accessories required to suspend the system from the building structure. Provide backstop capable of being height adjusted from 8'-0" to 10'-0" above finished floor.
 1. Frame: Backstops shall be a welded together main frame constructed from steel mechanical tubing to form a rigid tetrahedral "T" design of back-to-back right triangles. The main stem (center strut) shall be 6" OD 11-gauge steel tubing, the top of the "T" shall be 4" OD 11-gauge steel tubing, and the side braces shall be 2¼" OD 14-gauge steel tubing. Side braces shall join stem no higher than 4'-6" above goal.
 2. Front Brace: The folding front brace shall be jackknife type, fully adjustable, self-locking in the down position and constructed of 2½" OD 13-gauge (outer) steel tubing and 2¼" OD 14-gauge (inner) steel tubing
 3. Support Framing: Manufacturer's standard min. 4" O.D. pipe secured to the building structural framing by means of precision die-formed metal support fittings. Reinforce and brace framing as required to provide rigid and secure support.
 4. Hoist Cable: 1/4 inch diameter galvanized aircraft cable with 7000 lb ultimate breaking strength.
 5. Basis of Design Product: EZ Fold TF-20S by Draper or equal.
- B. Accessories:
 1. Back Board Height Adjustment: Provide system mounting directly to backstop specified to eliminate any strain on the backboard should a player hang on the front goal. Incorporate a compact 115 volt, gear motor type linear actuator with 600

- pound thrust capacity to raise and lower the goal height electronically, with integral limit switches automatically shut off at 8' and 10' goal heights, and controlled by a removable Powr-Stick portable electric control. Draper No. 503096
2. Winch: Heavy duty electric winch designed to hold unit at any position when raising or lowering. Provide individually operated flush mounted hesitation type key switch for each backstop. Provide winch with fully enclosed worm gear set which does not require lubrication; gear shaft connected directly to hoist drum without chains; 1 HP motor, 120 VAC.
 - a. Basis of Design Product: Draper 503085 or equal.
 3. Safety Lock: Fully automatic and resetting retracting spring inertia type lock with 2 inch wide nylon belt strap rated at 6,000 lbs inside cast aluminum housing, secured to overhead superstructure, extending a maximum of 35 feet. Provide unit designed to automatically lock backstop in position at any time in storage or during the raising or lowering cycle due to sudden surge of speed or malfunction. Provide at all folding backstops
 - a. Basis of Design Product: Draper 503049 Posilock or equal
 4. Retractor Reel: Reel designed to mount near the upper hinge point of the backstop drop frame to automatically retract both the hoist cable and safety lock strap from the area of play when the backstop is in the down position. Provide for main court units
 5. Power Control Unit: PowerStick that includes a rotary control switch with UP and DOWN positions and a center off position that plugs into a special receptacle mounted on the height adjuster frame. Quantity: 1.

2.4 BACKBOARDS AND GOALS (Provide at each backstop)

- A. Backboards: Provide 72" x 42" rectangular glass superboard backboards with extruded aluminum frame, and border and target "fired in" for permanence; unitized welded strut adapter designed to transfer impact loading on goal directly to the perimeter structural framing; molded high density polyurethane foam safety padding with continuous integral steel attachment channels designed to bolt on to backstop;
 1. Backstop Basis of Design Product: Draper 503136 or equal.
 2. Safety Padding Basis of Design Product: Color as selected by Architect.
- B. Breakaway Goal and Net: Movable, breakaway design with manufacturer's standard breakaway mechanism including positive-lock, adjustable pressure release, complying with NCAA and NFHS specifications, and automatic reset. Provide movable ring with rebound characteristics identical to those of fixed, nonmovable ring
 1. Basis of Design Product: Draper 503576 or equal

2.5 WALL PROTECTION MATS

- A. Basis of Design Product: Jaypro Wallguard Fire/Impact Wall Padding, or equivalent.

- B. Wall protection mats shall consist of wall-mounted padded panels and all necessary support framing and accessories required to secure the system to the building walls, columns and doors.
- C. Wall Protection Mats: Bonded polyurethane fire-retardant high impact foam filler padding cemented to min. 7/16" thick fire retardant OSB backing and covered with a flame retardant vinyl-coated nylon fabric. Fabric shall meet NFPA 701. Bull nose perimeter, and fold, wrap, and staple face fabric to the back of the backing. Extend the plywood backing beyond the top and bottom edges of the padding to provide a nailing strip for securing the mat to the wall.
- D. Wall Mat Dimensions: 2" thick by 6' -0" high by 2' -0" wide, unless otherwise noted. Fabricate special panels for those wrapping corners, columns, or indicated to have non-standard shapes or configuration. Provide custom cut-outs for all wall-mounted electrical devices and other items indicated.
- E. Furring: Wood furring wrapped in vinyl fabric matching pads. Provide continuous at top, mid point and bottom of pads, and at ends of runs.
- F. Panel Fabric Color: As selected by Architect from manufacturer's standard colors selections.

2.6 FLOOR SLEEVES

- A. Badminton Floorplate and Sleeve: 5-1/4" outside diameter solid brass floorplate with tubular steel sleeve; Sports Imports Model KA45 or equal.
- B. Volleyball Floorplate and Sleeve: 6-5/8" outside diameter solid brass floorplate with tubular steel sleeve; Sports Imports Model KA25 or equal.

PART 3 - EXECUTION

3.1 EXAMINATION

- A. Examine substrates, areas, and conditions, with Installer present, for compliance with requirements for alignment of mounting substrates, installation tolerances, operational clearances, accurate locations of connections to building electrical system, and other conditions affecting performance.
 - 1. Verify critical dimensions.
 - 2. Examine supporting structure.
 - 3. Examine wall assemblies, where reinforced to receive anchors and fasteners, to verify that locations of concealed reinforcements have been clearly marked. Locate reinforcements and mark locations.
 - 4. Proceed with installation only after unsatisfactory conditions have been corrected.

3.2 INSTALLATION

- A. Deliver gymnasium equipment to project site when spaces or building components which are to receive them have been completed.
 - 1. Do not install wall protection mats until wall finishes have been installed or applied.
- B. Install the gymnasium equipment in accordance with manufacturer's recommendations.
- C. Coordinate with other trades (structural framing, wall finishes, electrical wiring and components) for associated work which needs to be completed or sequenced with the work of this Section.
- D. Assemble/install gymnasium equipment in location shown or directed by Architect, and verify that components are complete and in proper working order.
- E. Instruct Owner's designated personnel in proper handling, use, adjusting, and maintenance of units.

3.3 ADJUSTMENT AND CLEANING

- A. Upon completion of installation, including work of other trades, lubricate, test, and adjust each gymnasium equipment to operate easily and in compliance with manufacturer's specifications.
- B. Clean installed equipment on exposed and semiexposed surfaces. Touch up shop-applied finishes to restore damaged or soiled areas.

3.4 PROTECTION

- A. Provide final protection and maintain conditions, in a manner acceptable to manufacturer and Installer, that ensures that gymnasium equipment is without damage or deterioration at time of Substantial Completion.

END OF SECTION 114900

SECTION 115213 - PROJECTION SCREENS

PART 1 - GENERAL

1.1 SUMMARY

- A. This Section includes the following:
 - 1. Electrically operated front projection screens.
- B. Related Sections: The following Sections contain requirements that relate to this Section:
 - 1. Division 26 Sections for electrical wiring, connections, and installation of control switches for electrically operated projection screens.

1.2 SUBMITTALS

- A. Product data for each type of screen specified.
- B. Shop drawings showing layout and types of projection screens. Include the following:
 - 1. Location of screen centerline relative to ends of screen case.
 - 2. Location of wiring connections.
 - 3. Location of seams in viewing surfaces.
 - 4. Drop length.
 - 5. Connections to supporting structure for pendant- and recess-mounted screens.
 - 6. Anchorage details.
 - 7. Details of juncture of exposed surfaces with adjacent finishes.
 - 8. Frame details.
 - 9. Accessories.
 - 10. Wiring Diagrams: For electrically operated units.
- C. Maintenance Data: For projection screens to include in maintenance manuals.

1.3 QUALITY ASSURANCE

- A. Single Source Responsibility: Obtain screens from a single manufacturer as a complete unit, including necessary mounting hardware and accessories.
- B. Electrical Components, Devices, and Accessories: Listed and labeled as defined in NFPA 70, Article 100, by a testing agency acceptable to authorities having jurisdiction, and marked for intended use.

1.4 DELIVERY, STORAGE, AND HANDLING

- A. Do not deliver projection screens until building is enclosed, other construction within spaces where screens will be installed is substantially complete, and installation of screens is ready to take place.

1.5 COORDINATION

- A. Coordinate layout and installation of projection screens and ceiling-mounted projector mounts with adjacent construction, including ceiling framing, light fixtures, HVAC equipment, fire-suppression system, and partitions.

PART 2 - PRODUCTS

2.1 ELECTRICALLY OPERATED FRONT PROJECTION SCREENS

- A. Electrically Operated Front Projection Screens, General: Manufacturer's standard units consisting of case, screen, motor, controls, mounting accessories, and other components necessary for a complete installation. Provide units that are listed and labeled as an assembly by UL or another testing and inspecting agency acceptable to authorities having jurisdiction.
 - 1. Line Voltage Control: Remote, 3-position control switch installed in recessed metal device box with flush cover plate.
 - a. Single Station Control Switch: Sustained contact, rocker switch for 110-120V current.
 - b. Color of Cover Plate and Rocker Switch: White
 - 2. Motor in Roller: Instant-reversing motor of size and capacity recommended by screen manufacturer; with permanently lubricated ball bearings, automatic thermal-overload protection, preset limit switches to automatically stop screen in up and down positions, and positive-stop action to prevent coasting. Mount motor inside roller with vibration isolators to reduce noise transmission.
 - 3. Screen Mounting: Top edge securely anchored to rigid metal roller and bottom edge formed into a pocket holding a 3/8-inch- (9.5-mm-) diameter metal rod with ends of rod protected by plastic caps.
 - a. Roller for motor in roller supported by vibration- and noise-absorbing supports.
- B. Electrically Operated Screens for Surface Mounting to Wall or Ceiling: Motor in roller units designed and fabricated for surface mounting to wall or ceiling surfaces; with aluminum case enclosing screen roller.
 - 1. Basis of Design Product: Provide Da-Lite Cosmopolitan by Legrand AV Inc., or equal by one of the following:
 - a. Draper Inc.
 - b. Stewart Filmscreen Corporation
 - 2. Provide metal or metal-lined wiring compartment on units with motor in roller.

3. Screen Case: Extruded aluminum, white finish.
 4. Provide screen case with metal brackets for mounting to wall or ceiling surfaces as required.
 5. Motor: 110-120 VAC.
 6. Provide integrated low voltage control unit and wireless remote control.
- C. Screen Material and Viewing Surface: Flexible projection fabric with gain of 1.0, and half angle of 60 degrees
1. Basis of Design Products: Provide Da-Lite Matte White by Legrand AV Inc., or equal by one of the following:
 - a. Draper Inc.
 - b. Stewart Filmscreen Corporation.
 2. Mildew Resistance: Rating of 0 or 1 when tested according to ASTM G 21.
 3. Flame Resistance: Passes NFPA 701.
 4. Seamless Construction: Provide screens in sizes indicated, without seams.
 5. Edge Treatment: Black masking borders.
 6. Provide additional black drop in locations as indicated on Drawings
 7. Screen format: 16:10 Wide Format
 8. Size of Viewing Surface: 72-1/2"h x 116"w.

PART 3 - EXECUTION

3.1 INSTALLATION

- A. General: Install projection screens at locations indicated to comply with screen manufacturer's written instructions.
- B. Install front projection screens with screen cases in position and relationship to adjoining construction as indicated, securely anchored to supporting substrate, and in manner that produces a smoothly operating screen with plumb and straight vertical edges and plumb and flat viewing surfaces when screen is lowered.
 1. Test electrically operated units to verify that screen, controls, limit switches, closure and other operating components are in optimum functioning condition.

3.2 PROTECTION AND CLEANING

- A. Protect projection screens after installation from damage during construction. If despite such protection damage occurs, remove and replace damaged components or entire unit as required to provide units in their original, undamaged condition.

END OF SECTION 115213

SECTION 11 68 14 – PLAYGROUND SURFACING

PART 1 GENERAL

1.1 SUMMARY

- A. This Section includes playground surfacing meeting the recommendations set forth by Consumer Product and Safety Commission, ASTM standards, and the Americans with Disabilities Act.

1.2 REFERENCES

- A. Materials and installation shall be in accordance with the latest revisions of the following codes, standards and specifications, except where more stringent requirements have been specified herein:
 - 1. American Society for Testing and Materials (ASTM)
 - a. F1292-13 Standard Specification for Impact Attenuation of Surfacing Materials Within the Use Zone Playground Equipment
 - b. F1951-08 Standard Specification for Determination of Accessibility of Surface Systems Under and Around Playground Equipment
 - c. D2047-13 Method for Static Coefficient of Friction of Polish-Coated Flooring Surfaces as Measured by the James Machine
 - 2. Americans with Disabilities Act Accessibility Guidelines
 - 3. Uniform Federal Accessibility Standards (UFAS) FED-SD-795
 - 4. Architectural and Engineering Instructions (9AI) Design Criteria

1.3 SUBMITTALS

- A. In addition to those submittals identified in the General Provisions, the following items shall be submitted:
 - 1. One original hard copy of the submittal package will be provided upon request.
 - 2. Manufacturer's descriptive data and installation instructions.
 - 3. Manufacturer's details showing depths of wear course, sub-base materials and edge details.
 - 4. Upon request, a listing of as least three installations where products similar to those proposed for use have been installed and have been in service for

a minimum of three years. This list shall include address of installation, date of installation, contact person and phone number.

5. A signed statement by an authorized official certifying that the surfacing system meets the requirements of ASTM F 1292-13 for a head first fall from the highest accessible play surface.
 6. A signed statement from the manufacturer of the poured-in-place surfacing attesting that all materials under this section shall be installed only by the Manufacturer's Trained Installers.
 7. A certificate of insurance shall be provided by the manufacturer / installer for poured-in-place surfacing for use as playground safety surfacing covering both general and product liability, of not less than \$1,000,000 for each occurrence, \$2,000,000 general aggregate. The issuing underwrite shall be AA rated.
 8. Upon request, a 3" round sample of the material for this project.
- B. Samples of any material shall be submitted at the Engineers request.

1.4 PERFORMANCE REQUIREMENTS

- A. Area Safety: Poured-in-place surfacing within playground equipment use zones shall meet or exceed the performance requirements of ADA, CPSC, and Fall Height Test ASTM F 1292-13. The surface must yield both, a peak deceleration of no more than 200 G-max and a Head Injury Criteria (HIC) value of no more than 1,000 for a head first fall from the highest designated play surface of the play equipment being installed.
- B. Accessibility Note: Children's outdoor play areas shall be in compliance with the Uniform Federal Accessibility Standards (UFAS) FED-STD-795 and the Architectural and Engineer Instructions (9AEI) Design Criteria. The requirements of the Americans with Disabilities Act Accessibility Guidelines (ADAAG) 28 CFR Part 36 that provide equal or greater accessibility than the requirements of UFAS must also be met in the children's outdoor play areas.
- C. Surface intends to serve as an accessible path of travel for persons with disabilities shall be firm, stable and slip resistant, and shall meet the requirements of ASTM 1951-08, ASTM 1292-13, and ASTM D2047.
- D. Surfaces shall be manufactured and installed by trained, experienced company employees.

1.5 DELIVERY, STORAGE AND HANDLING.

- A. All materials and equipment shall be delivered and stored in accordance with the manufacturer's recommendations.

1.6 PROJECT SITE CONDITIONS

- A. Poured-in-place surfacing must be installed on a dry 2" asphalt binder course, with no prospect of steady or heavy rain within the initial drying period, and within the recommended temperature range of the manufacturer. Installation in weather conditions of extreme heat, cold (less than 45 degree F), and/or high humidity may affect cure time, and the structural integrity of the final product. Immediate surrounding sites must be reasonably free of dust conditions or this could affect the look of the final surface.
- B. Sequencing and Scheduling: Poured-in-place surfacing shall be installed after all playground equipment, shade structures, signs and any other items that will be within the surfacing area. Surface installation will be coordinated by an approved installer.

1.7 WARRANTY

- A. Poured-in-place surface shall maintain required impact attenuation characteristics and be guaranteed against defects in workmanship and materials for a limited five (5) year period or as specified and agreed upon per alternate contract. Warranty will be specific to maintenance requirements and performance standards of completed product.

PART 2 PRODUCTS

2.1 MANUFACTURERS

- A. The following manufacturers are named to establish a standard of quality necessary for the Project.
 - 1. Soft Fusion manufactured by A & D Recreation, Inc. (Mamaroneck, NY)
 - 2. Or equal

2.2 PRODUCT SCOPE

- A. Poured-in-place surface shall consist of 100% recycled SBR rubber material mixed with a polyurethane binder and capped with EPDM or TPV granule mixed with a polyurethane binder. It shall consist of a uniform material manufactured in such a way that the top portion meets the requirements specified herein for wear surface. The type of safety surfacing shall be a poured-in-place system and shall be indicated on the drawings.

2.2 CUSHION LAYER SECTION

- A. Impact Attenuating Cushion Layer: Cushion Layer consists of shredded styrene butadiene rubber (SBR) adhered with a 100% solids polyurethane binder to form a resilient porous material. Strands of SBR may vary from 0.5 mm to 2.0 mm in

thickness by 3.0 mm to 20mm in length. Foam or standard rubber granules are not to be permitted in Cushion Layer.

- B. Binder shall be between 12-14% of the total weight of the material, and shall provide 100% coating of the SBR particles. The Cushion Layer shall be compatible with the Wear Course and must meet requirements herein for impact attenuation.

2.3 WEAR COURSE

- A. Wear Course shall consist of Ethylene Propylene Diene Monomer (EPDM) or Thermal Plastic Vulcanized (TPV) granules with a polyurethane binder formulated to produce a porous, uniform, seamless surface up to 2,000 square feet.
- B. EPDM shall be peroxide cured with an EPDM content of 26% and shall include a Processing aid to prevent hardness with 26% poly content to maintain dynamic testing characteristics, weatherization and UV stability.
- C. ASTM D 2240 (Shore A) hardness of 55-65, not less than 26% rubber hydrocarbons.
- D. Size of EPDM granules shall be 2-4mm across. Binder shall be not less than 20% of total weight of rubber used in the Wear Course, and shall provide 100% coating of the EPDM particles.
- E. TPV shall be angular granules with a (Shore A) hardness of 55-65 and particle size between 1-4mm. Binder shall be not less than 20% of total weight of rubber used in the Wear Course, and shall provide 100% coating of the EPDM particles.
- F. Thickness of Wear course shall be ½”.
- G. Coefficient of Friction, when wet: 0.80, minimum, when tested in accordance with ASTM D2047.

2.4 BINDER

- A. No Toluene Diphenel Isocyanate (TDI) shall be used.
- B. No filler materials shall be used in urethane such as plasticizers and the catalyzing agent shall contain no heavy metals.
- C. Weight of polyurethane shall be no less than 8 ½ lbs. /gal and no more than 9 ½ lbs. /gal.
- D. Manufacturer is permitted to modify the type of urethane required to match extreme weather conditions.

E. Substitutions must be equal to or exceed original quality.

2.4 MATERIALS

A. Materials shall be or equal to:

Wear Course- EPDM Granules

Manufacturer- Midwest Elastomers, Inc.
As Distributed by- A & D Recreation, Inc.
Location Used- Playground Area

Wear Course- TPV Granules

Manufacturer- American Rubber
As Distributed by- A & D Recreation, Inc.
Location Used- Playground Area

Cushion Layer- Shredded SBR

Manufacturer- Midwest Elastomers, Inc. or American Rubber
As Distributed by- A & D Recreation, Inc.
Location Used- Playground Area

Binder- Stobielast S 136.00- Normal Weather Conditions

Manufacturer- Stockmeier Urethanes
As Distributed by- A & D Recreation, Inc.
Location Used- Playground Area

Binder- Stobielast S 106.00- Extreme Heat and Humidity

Manufacturer- Stockmeier Urethanes
As Distributed by- A & D Recreation, Inc.
Location Used- Playground Area

Binder- Stobielast S 36.99- Cold and Arid Conditions

Manufacturer- Stockmeier Urethanes
As Distributed by- A & D Recreation, Inc.
Location Used- Playground Area

Binder- Stobielast S 151.99- Aliphatic

Manufacturer- Stockmeier Urethanes
As Distributed by- A & D Recreation, Inc.
Location Used- Playground or Water Play Areas

PART 3 EXECUTION

3.1 SITE PREPARATION

- A. Finished Grade/Slope: Verify that finished elevations of adjacent areas are as indicated on the architectural or site plans, that the appropriate sub-grade elevation has been established for the particular safety surface to be installed, and that the subsurface has been installed per architectural, site or equipment plans while meeting accessibility and use zone requirements.
- B. Sub Base: Sub base may be asphalt, concrete, or aggregate. Tolerance of sub base shall be within 1/8" in 10'. Verify that aggregate sub base has been fully compacted in 2" watered lifts to 95% or greater.
- C. Curing of Asphalt and Concrete: If poured-in-place surfacing is installed, verify that concrete sub base has cured (all areas appear white in color usually between 3-7 days) and that all concrete curing compound and other deleterious substances that might adversely affect adhesion have been removed. Surface shall be clean and dry. Asphalt cure time requires 14 days. Once the new asphalt has cured, it must be pressure washed prior to the surfacing being installed. The contractor shall be responsible for flooding the pad to insure proper slope and tolerance. Any Areas holding enough water to cover a flat nickel shall be patched prior to arrival of our installation crews.
- D. Drainage: Verify that sub-surfacing drainage, if required, has been installed to provide positive drainage.

3.2 INSTALLATION

- A. Poured-in-Place Surfacing: Components of the poured-in-place surfacing shall be mixed on site in a rotating tumbler to ensure components are thoroughly mixed and are in accordance with manufacturer's recommendations. Installation of surfacing shall be seamless up to 2,000 square feet per day and completely bonded to sub base. Material shall cover all foundations and fill around all elements penetrating the surface.
- B. Cushion Layer: Whenever practical, cushion layer of surfacing material shall be installed in one continuous pour on the same day of up to 2,000 square feet. When a second pour is required, step the seam and fully coat the step of the previous work with polyurethane binder to ensure 100% bond with new work. Apply adhesive in small quantities so that new cushion layer can be placed before the adhesive dries.
- C. Wear Course: Wear Course must be either high quality peroxide cured EPDM or TPV granules. Wear surface shall be bonded to Cushion Layer. If necessary, additional primer will be used between the Cushion Layer and Wear Course. Apply adhesive to Cushion Layer in small quantities allowing the Wear Course to be applied before the adhesive dries. Surface shall be hand troweled to a smooth, even finish. Except where the Wear Course is composed of differing color patterns, pour shall be

continuous and seamless up to 2,000 square feet per day. Where seams are required due to color change, size, or adverse weather, a step configuration will be constructed to maintain Wear Course integrity. The edge of initial pour shall be coated with adhesive and wearing surface mixture shall be immediately applied. Pads with multiple seams are encouraged to include a top coat of urethane binder before being placed into use. Butt joint seams are not acceptable except for repairs. Under special conditions and with owner's written approval, seams may be permitted in the same color pad. Consult with manufacturer for specific applications.

- D. Perimeter: For installations over new or existing concrete, the perimeter must be saw cut to provide a keyway 1" deep by 1" wide, or formed during pour, with surfacing rolled down inside void. Primer adhesive must be applied to all sides of the void. When connecting to a concrete curb or border the inside vertical edge shall be primed with adhesive and the final 2" of the Cushion Layer shall be tapered to allow the wear surface material to be 1 1/5" to 2" thick where it joins the concrete edge.
- E. For installations over new or existing asphalt, a curb or other type of border must be installed around the entire pad. Primer adhesive must be applied to the inside vertical edge of the border before poured-in-place surfacing installation.
- F. Thickness: Construction methods, such as the use of measured screeds or guides shall be employed to ensure that the full depth of specified surfacing material is installed. Surfacing system thickness throughout the playground equipment use zone shall be as required to meet the impact attenuation requirements specified herein.
- G. Clean up: Manufacturer's installers shall work to minimize excessive adhesive on adjacent surfaced or play equipment. Spills of excess adhesive shall be promptly cleaned.
- H. Protection: The safety surface shall be allowed to fully cure in accordance with the Manufacturer's instructions. The surfacing shall be protected by the owner from all traffic during the curing period of 48 hours or as instructed by the manufacturer.

END OF SECTION 11 68 14

SECTION 116843 – SCOREBOARDS AND ACCESSORIES

PART 1 - GENERAL

1.1 SUMMARY

A. Section Includes:

1. Single-sided LED basketball (multi-sport) scoreboards.
2. Single-sided LED basketball game/shot clocks.
3. Control console.

B. Related Requirements:

1. Division 26 Sections for conduit, wiring, junction boxes and other electrical components required for scoreboards and accessories.
2. Division 27 Sections for data connections required for scoreboards and accessories.

1.2 ACTION SUBMITTALS

A. Product Data: For each type of product.

B. Shop Drawings: For scoreboards and accessories.

1. Include fabrication and installation details and attachments to other work.
2. Show scoreboard mounting heights, locations of supplementary supports to be provided by other installers, and accessories.
3. Show message list, tpestyles, graphic elements, and layout for each scoreboard.
4. Show locations of electrical service and data connections.
5. Include diagrams for power, signal, and control wiring.

1.3 INFORMATIONAL SUBMITTALS

A. Qualification Data: For Installer.

B. Sample Warranty: For special warranty.

1.4 CLOSEOUT SUBMITTALS

A. Maintenance Data: For scoreboards and accessories to include in maintenance manuals.

1.5 QUALITY ASSURANCE

- A. Installer Qualifications: Manufacturer of scoreboards and accessories or an entity that employs installers and supervisors who are trained and approved by manufacturer.
- B. Single Source Responsibility: Scoreboards and accessories shall be provided by a single manufacturer.

1.6 FIELD CONDITIONS

- A. Environmental Limitations: Do not install scoreboards until finishes are in place in the area of installation and environmental conditions are within ranges acceptable to scoreboard manufacturer.
- B. Field Measurements: Verify actual locations of walls and other construction contiguous with scoreboards by field measurements before fabrication and indicate measurements on Shop Drawings.

1.7 WARRANTY

- A. Special Warranty: Manufacturer agrees to repair or replace components of scoreboards that fail in materials or workmanship within specified warranty period.
 - 1. Warranty Period: One year from date of Substantial Completion.

PART 2 - PRODUCTS

2.1 PERFORMANCE REQUIREMENTS

- A. Electrical Components, Devices, and Accessories: Listed and labeled as defined in NFPA 70, by a qualified testing agency, and marked for intended location and application.
- B. ETL listed to UL 48
- C. NEC compliant
- D. FCC compliant
- E. ETL listed to CSA 22.2 #207

2.2 SCOREBOARDS

- A. Scoreboard: Indoor single-sided LED basketball scoreboard displays period time to 99:59, HOME and GUEST scores to 99, PERIOD to nine, PLAYER to 99, PLAYER FOUL to 9, PLAYER POINTS to 99, TEAM FOULS to 99, TIME OUTS LEFT to 9 and

indicates possession and bonus. Scoreboard can also score volleyball and wrestling. During the last minute of the period, the clock displays time to 1/10 of a second. Provide the following features:

1. Basis of Design Product: Daktronics BB-3123 Scoreboard by Daktronics, Inc., or equal by one of the following:
 - a. NEVCO
 - b. Varsity Scoreboards
2. Construction: Aluminum alloy 5052 sheet; scoreboard back, face, and perimeter: 0.063" thick
3. Dimensions: 6'-0" high, 10'-0" wide, 6" deep
4. Weight: 260 Lbs.
5. Power Requirements: 120VAC, 400W, 3.3 Amp
6. Face Color: As selected by Architect.
7. Digits: Amber/Red/Green LED color digits, ColorSmart® LED digit technology.
8. Captions: Vinyl, in color selected by Architect. HOME and GUEST captions: 6" high and all other captions: 4" high. FOUL AND PLYR/FOUL/PTS captions are on changeable panels, all other captions applied directly to scoreboard face.
9. Accessories:
 - a. Vinyl striping applied around scoreboard face; color as selected by Architect.
 - b. Horn
 - c. Standalone Time of Day (scoreboard acts as a clock when control console is unplugged/off)
 - d. Wireless radio receiver 2.4 GHz; two controllers required, one for each scoreboard.
 - e. Volleyball and wrestling captions applied to a reversable caption panel.

2.3 GAME AND SHOT CLOCKS

- A. Single-sided basketball game and shot clock timer displays game time to 99:59 and shot times up to a value of 99 seconds. It can also count down from any preset time between 0 and 99 seconds. During the last minute of the period, game time is displayed to 1/10 of a second. A hand-held start/stop/reset switch is included. Provide the following features:
 1. Basis of Design Product: Daktronics BB-2115 Game/Shot Clock by Daktronics, Inc., or equal by one of the following:
 - a. NEVCO
 - b. Varsity Scoreboards
 2. Construction: Aluminum alloy 5052 sheet; scoreboard back, face, and perimeter: 0.063" thick
 3. Dimensions: 2'-4" high, 2'-5" wide, 6" deep
 4. Weight: 30 Lbs.

5. Power Requirements: 120VAC, 50W, 0.5 Amp
6. Face Color: As selected by Architect.
7. Digits: Amber LED color game clock digits and red LED color shot clock digits, PanaView® LED digit technology.
8. Accessories:
 - a. Horn
 - b. Wireless radio receiver 2.4 GHz

2.4 CONTROL CONSOLE

- A. Scoring Console: Wireless console shall be capable of scoring multiple sports using changeable keyboard inserts, recalling clock, score, and period information if power is lost, and running Time of Day and Segment Timer modes.
 1. Basis of Design Product: All Sport 5000 Controller by Daktronics, or equal by one of the following:
 - a. NEVCO
 - b. Varsity Scoreboards
 2. Features:
 - a. Aluminum enclosure to house electronics
 - b. Sealed membrane water-resistant keyboard
 - c. 32-character LCD to verify entries and recall information currently displayed
 - d. Power cord that plugs into a standard grounded outlet; 3 watts max
 - e. Soft-sided carrying case
 3. Accessories: 2.4 GHz spread spectrum radio system with frequency hopping technology and 64 non-interfering channels; system includes a transmitter installed inside the console and a receiver installed inside the scoreboard(s)

PART 3 - EXECUTION

3.1 EXAMINATION

- A. Examine substrates, areas, and conditions, with Installer present, for compliance with requirements for installation tolerances and other conditions affecting performance of the Work.
- B. Verify that scoreboard support surfaces are within tolerances to accommodate scoreboards.
- C. Verify that data and electrical service is correctly sized and located to accommodate scoreboards. Verify that placement of conduit and junction boxes are as specified and indicated in plans and shop drawings

- D. Proceed with installation only after unsatisfactory conditions have been corrected.

3.2 SCOREBOARD INSTALLATION

- A. General: Install scoreboards using installation methods indicated and according to manufacturer's written instructions and approved shop drawings.
 - 1. Install scoreboards level, plumb, and at locations and heights indicated, with scoreboard surfaces free of distortion and other defects in appearance.
 - 2. Before installation, verify that scoreboard components are clean and free of materials or debris that would impair installation.
 - 3. Install scoreboard control wiring in conduit as per approved shop drawings.

3.3 CONTROLLER INSTALLATION

- A. Provide boxes, cover plates and jacks in locations per plans.
- B. Test connect control unit to all jacks and check for proper operation of control unit, scoreboard and all features. Leave control unit in carrying case and other loose accessories with Owner's designated representative.

3.4 TESTING, ADJUSTING AND CLEANING

- A. Remove and replace damaged or deformed scoreboards and scoreboards that do not comply with specified requirements. Replace scoreboards with damaged or deteriorated finishes or components that cannot be successfully repaired by finish touchup or similar minor repair procedures.
- B. Remove temporary protective coverings and strippable films as scoreboards are installed.
- C. On completion of installation, clean exposed surfaces of scoreboards according to manufacturer's written instructions, and touch up minor nicks and abrasions in finish. Maintain scoreboards in a clean condition during construction and protect from damage until acceptance by Owner.
- D. Test operation of scoreboards, shot clocks, and other accessories for complete range of possible functions.

3.5 DEMONSTRATION AND TRAINING

- A. Instruct Owner's personnel in proper use, operation, and maintenance of scoreboards and accessories. Train Owner's personnel in procedures to follow in identifying sources of operational failures or malfunctions.

13 January 2022
Conformed Specifications
SED #66-23-00-01-0-346-001

Yonkers Joint Schools Construction Board
Community School 35

END OF SECTION 116843

Casework Schedule

New Community School at the St. Denis Site

ROOM LOCATION	ITEM	TAG	QTY	COMPANY/COMPANY ITEM TYPE	DESCRIPTION
FIRST FLOOR					
<u>102</u> Main Office	Teacher's Wardrobe & Storage	S-15	1	Sheldon Laboratory Systems T358222-721 - 35"W	
<u>103</u> Pre-K Classroom-2	Tall Double Door Storage Cabinet	S-10	1	Sheldon Laboratory Systems T358216-200 - 35"W	
	Teacher's Wardrobe & Storage	S-15	1	Sheldon Laboratory Systems T358222-721 - 35"W	
<u>104</u> Pre-K Classroom-1	Tall Double Door Storage Cabinet	S-10	1	Sheldon Laboratory Systems T358216-200 - 35"W	
	Teacher's Wardrobe & Storage	S-15	1	Sheldon Laboratory Systems T358222-721 - 35"W	
<u>112</u> Pre-K Classroom-4	Tall Double Door Storage Cabinet	S-10	1	Sheldon Laboratory Systems T358216-200 - 35"W	
	Teacher's Wardrobe & Storage	S-15	1	Sheldon Laboratory Systems T358222-721 - 35"W	
<u>113</u> Pre-K Classroom-3	Tall Double Door Storage Cabinet	S-10	1	Sheldon Laboratory Systems T358216-200 - 35"W	
	Teacher's Wardrobe & Storage	S-15	1	Sheldon Laboratory Systems T358222-721 - 35"W	
SECOND FLOOR					
<u>201</u> Kindergarten-2	Tall Double Door Storage Cabinet	S-10	1	Sheldon Laboratory Systems T358216-200 - 35"W	
	Teacher's Wardrobe & Storage	S-15	1	Sheldon Laboratory Systems T358222-721 - 35"W	
<u>202</u> Kindergarten-1	Tall Double Door Storage Cabinet	S-10	1	Sheldon Laboratory Systems T358216-200 - 35"W	
	Teacher's Wardrobe & Storage	S-15	1	Sheldon Laboratory Systems T358222-721 - 35"W	
<u>204</u> 2nd Grade Classroom-1	Tall Double Door Storage Cabinet	S-10	1	Sheldon Laboratory Systems T358216-200 - 35"W	
	Teacher's Wardrobe	S-16L	1	Sheldon Laboratory Systems T248216-121 - 24"W LH	
<u>205</u> 2nd Grade Classroom-2	Tall Double Door Storage Cabinet	S-10	1	Sheldon Laboratory Systems T358216-200 - 35"W	
	Teacher's Wardrobe	S-16R	1	Sheldon Laboratory Systems T248216-120 - 24"W RH	
<u>206</u> 2nd Grade Classroom-3	Tall Double Door Storage Cabinet	S-10	1	Sheldon Laboratory Systems T358216-200 - 35"W	
	Teacher's Wardrobe	S-16L	1	Sheldon Laboratory Systems T248216-121 - 24"W LH	
<u>210</u> 1st Grade Classroom-2	Tall Double Door Storage Cabinet	S-10	1	Sheldon Laboratory Systems T358216-200 - 35"W	
	Teacher's Wardrobe	S-16L	1	Sheldon Laboratory Systems T248216-121 - 24"W LH	
<u>211</u> 1st Grade Classroom-3	Tall Double Door Storage Cabinet	S-10	1	Sheldon Laboratory Systems T358216-200 - 35"W	
	Teacher's Wardrobe	S-16R	1	Sheldon Laboratory Systems T248216-120 - 24"W RH	
<u>217</u> 1st Grade Classroom-1	Tall Double Door Storage Cabinet	S-10	1	Sheldon Laboratory Systems T358216-200 - 35"W	
	Teacher's Wardrobe	S-16R	1	Sheldon Laboratory Systems T248216-120 - 24"W RH	
<u>218</u> Kindergarten-3	Tall Double Door Storage Cabinet	S-10	1	Sheldon Laboratory Systems T358216-200 - 35"W	
	Teacher's Wardrobe & Storage	S-15	1	Sheldon Laboratory Systems T358222-721 - 35"W	
<u>220</u> Special Education	Tall Double Door Storage Cabinet	S-10	1	Sheldon Laboratory Systems T358216-200 - 35"W	
	Teacher's Wardrobe	S-16L	1	Sheldon Laboratory Systems T248216-121 - 24"W LH	
THIRD FLOOR					

<u>301</u> 4th Grade Classroom-2	Tall Single Door Storage Cabinet	S-13L	1	Sheldon Laboratory Systems T188216-101 - 18"W LH	
	Teacher's Wardrobe	S-16R	1	Sheldon Laboratory Systems T248216-120 - 24"W RH	
<u>302</u> 4th Grade Classroom-1	Tall Single Door Storage Cabinet	S-13R	1	Sheldon Laboratory Systems T188216-100 - 18"W RH	
	Teacher's Wardrobe	S-16L	1	Sheldon Laboratory Systems T248216-121 - 24"W LH	
<u>304</u> 3rd Grade Classroom-1	Tall Single Door Storage Cabinet	S-13R	1	Sheldon Laboratory Systems T188216-100 - 18"W RH	
	Teacher's Wardrobe	S-16L	1	Sheldon Laboratory Systems T248216-121 - 24"W LH	
<u>305</u> 3rd Grade Classroom-2	Tall Single Door Storage Cabinet	S-13L	1	Sheldon Laboratory Systems T188216-101 - 18"W LH	
	Teacher's Wardrobe	S-16R	1	Sheldon Laboratory Systems T248216-120 - 24"W RH	
<u>306</u> 3rd Grade Classroom-3	Tall Single Door Storage Cabinet	S-13R	1	Sheldon Laboratory Systems T188216-100 - 18"W RH	
	Teacher's Wardrobe	S-16L	1	Sheldon Laboratory Systems T248216-121 - 24"W LH	
<u>310</u> 5th Grade Classroom-2	Tall Single Door Storage Cabinet	S-13R	1	Sheldon Laboratory Systems T188216-100 - 18"W RH	
	Teacher's Wardrobe	S-16L	1	Sheldon Laboratory Systems T248216-121 - 24"W LH	
<u>311</u> 5th Grade Classroom-3	Tall Single Door Storage Cabinet	S-13L	1	Sheldon Laboratory Systems T188216-101 - 18"W LH	
	Teacher's Wardrobe	S-16R	1	Sheldon Laboratory Systems T248216-120 - 24"W RH	
<u>314</u> Art	Teacher's Wardrobe	S-16R	1	Sheldon Laboratory Systems T248216-120 - 24"W RH	
	Art Storage	DSW-1	1	Diversified Woodcrafts GSC-8 - 40"W	
<u>317</u> 5th Grade Classroom-1	Tall Single Door Storage Cabinet	S-13L	1	Sheldon Laboratory Systems T188216-101 - 18"W LH	
	Teacher's Wardrobe	S-16R	1	Sheldon Laboratory Systems T248216-120 - 24"W RH	
<u>318</u> 4th Grade Classroom-3	Tall Single Door Storage Cabinet	S-13L	1	Sheldon Laboratory Systems T188216-101 - 18"W LH	
	Teacher's Wardrobe	S-16R	1	Sheldon Laboratory Systems T248216-120 - 24"W RH	
<u>319b</u> Music Storage	Teacher's Wardrobe	S-16L	1	Sheldon Laboratory Systems T248216-121 - 24"W LH	Contains a full length straight grille door and 4 adjustable shelves
	Standard Music Storage	WG-01	2	Wenger UltraStor Adjust. Shelf Option 68"H_#78 (27 1/2"W x 29 1/4"D)	Contains a full length straight grille door and 4 adjustable shelves
	Standard Music Storage	WG-02	1	Wenger UltraStor Adjust. Shelf Option 68"H_#79 (27 1/2"W x 29 1/4"D)	Contains a full length straight grille door and 4 adjustable shelves
	Standard Music Storage	WG-03	2	Wenger UltraStor Adjust. Shelf Option 68"H_#81 (27 1/2"W x 29 1/4"D)	Contains a full length straight grille door and 4 adjustable shelves
	Standard Music Storage	WG-04	1	Wenger UltraStor Adjust. Shelf Option 68"H_#83 (48 1/2"W x 29 1/4"D)	Contains a full length straight grille door and 4 adjustable shelves
FOURTH FLOOR					
<u>401</u> 6-8 Grade Classroom-5	Teacher's Wardrobe & Storage	S-15	1	Sheldon Laboratory Systems T358222-721 - 35"W	
<u>402</u> 6-8 Grade Classroom-4	Teacher's Wardrobe & Storage	S-15	1	Sheldon Laboratory Systems T358222-721 - 35"W	
<u>404</u> 6-8 Grade Classroom-1	Teacher's Wardrobe & Storage	S-15	1	Sheldon Laboratory Systems T358222-721 - 35"W	
<u>405</u> 6-8 Grade Classroom-2	Teacher's Wardrobe & Storage	S-15	1	Sheldon Laboratory Systems T358222-721 - 35"W	
<u>406</u> 6-8 Grade Classroom-3	Teacher's Wardrobe & Storage	S-15	1	Sheldon Laboratory Systems T358222-721 - 35"W	

13 January 2022
Conformed Specifications
 SED #66-23-00-01-0-346-001

410	6-8 Grade Classroom-9	Teacher's Wardrobe & Storage	S-15	1	Sheldon Laboratory Systems T358222-721 - 35"W	
411	6-8 Grade Classroom-10	Teacher's Wardrobe & Storage	S-15	1	Sheldon Laboratory Systems T358222-721 - 35"W	
414	Science	Teacher's Desk w/ Sink	S-20	1	Sheldon Laboratory Systems Instructor Desk - 20696 (ADA)	Classic series Maple
		Student Tables	S-21	11	Sheldon Laboratory Systems Utility Table - U542430R	New Classic Style Designer Series Grizzly Gray Base w/ Black Top
		ADA Student Table	S-22	1	Sheldon Laboratory Systems Adjust. Student Table (ADA) - 19922	New Classic Style Designer Series Grizzly Gray Base w/ Black Top
		Microscope Cabinet	S-18	1	Sheldon Laboratory Systems T248216-171 - 24"W LH	
		Tall Double Door Storage Cabinet	S-12	1	Sheldon Laboratory Systems T308216-200 - 42"W	
		Sink Cabinet Double Double	S-S1	2	Sheldon Laboratory System S253622-200 - 35"W	Classic series Maple
		Sink Cabinet ADA Sink Casework	S-S2	1	Sheldon Laboratory System MODEL NUMBER? - 36"W (ADA 34"H)	Classic series Maple
		Base Cabinet Single Door with 1 Drawer	S-01R	2	Sheldon Laboratory Systems B183622-400 - 18"W RH	Classic series Maple
		Base Cabinet Single Door with 1 Drawer	S-01L	2	Sheldon Laboratory Systems B183622-401 - 18"W LH	Classic series Maple
		Base Cabinet Open Shelf	S-05	3	Sheldon Laboratory Systems B423622-000 - 42"W	Classic series Maple
		ADA Base Cabinet Single Door with 1 Drawer	S-02L	1	Sheldon Laboratory Systems B183622-401 - 18"W LH (ADA 34"H)	Classic series Maple
		ADA Base Cabinet Double Door with 1 Drawer	S-04	1	Sheldon Laboratory Systems B303622-410 - 35"W (ADA 34"H)	Classic series Maple
		Wall Cabinet Single Door - Solid	S-06R	2	Sheldon Laboratory Systems W183012-100 - 18"W RH	Classic series Maple
		Wall Cabinet Single Door - Solid	S-06L	2	Sheldon Laboratory Systems W183012-101 - 18"W LH	Classic series Maple
		Wall Cabinet Single Door - Solid	S-07R	1	Sheldon Laboratory Systems W243012-100 - 24"W RH	Classic series Maple
		Wall Cabinet Double Door - Solid	S-08	3	Sheldon Laboratory Systems W423012-200 - 42"W	Classic series Maple
		Wall Cabinet Double Door - Glass	S-09	2	Sheldon Laboratory Systems W353012-250 - 35"W	Classic series Maple
414a	Science Prep	Teacher's Wardrobe & Storage	S-15	1	Sheldon Laboratory Systems T358222-721 - 35"W	Classic series Maple
		Acid / Flammable Metal Storage	S-23	1	Sheldon Laboratory Systems SC4236 - 35"L	
		Sink Cabinet ADA Sink Casework	S-S2	1	Sheldon Laboratory System MODEL NUMBER? - 36"W (ADA 34"H)	Classic series Maple
		ADA Base Cabinet Single Door with 1 Drawer	S-03R	1	Sheldon Laboratory Systems B243622-400 - 24"W RH (ADA 34"H)	Classic series Maple
		ADA Base Cabinet Double Door with 1 Drawer	S-04	1	Sheldon Laboratory Systems B303622-410 - 35"W (ADA 34"H)	Classic series Maple
		ADA Base Cabinet Single Door with 1 Drawer	S-02L	1	Sheldon Laboratory Systems B183622-401 - 18"W LH (ADA 34"H)	Classic series Maple
417	6-8 Grade Classroom-8	Tall Double Door Storage Cabinet	S-15	1	Sheldon Laboratory Systems T358222-200 - 35"W	Classic series Maple
418	6-8 Grade Classroom-7	Tall Double Door Storage Cabinet	S-15	1	Sheldon Laboratory Systems T358222-200 - 35"W	Classic series Maple
419	Special Education	Tall Double Door Storage Cabinet	S-15	1	Sheldon Laboratory Systems T358222-200 - 35"W	Classic series Maple

The following additions, substitutions, or clarifications are extracted from the (5) Bid Addenda issued with this project during bidding. This insert is intended to summarize addendum information relevant to this specification section. See Bid Addenda issued by the City of Yonkers for complete contract document changes.

Bid Addendum No. 4:

Part 2 .2 Basis of Design Products

Item A. Manual Double Roll shades- Replace "Clutch- Operated Flexshade by Draper or equal" to "Provide Clutch -Operated Flexshade NEXD by Draper or equal"

Clarification- Type 6- Shades on doors- Provide Draper Flexshade CL single roller, blackout material

SECTION 122413 - ROLLER WINDOW SHADES

PART 1 - GENERAL

1.1 SUMMARY

- A. This Section includes
 - 1. Manual operation dual light-filtering and blackout shades.
 - 2. Manual operation light-filtering shades.
 - 3. Manual operation blackout shades.
 - 4. Motor operation blackout shades

1.2 ACTION SUBMITTALS

- A. Product Data: For each type of product indicated. Include styles, material descriptions, construction details, dimensions of individual components and profiles, features, finishes, and operating instructions.
 - 1. Motorized Shade Operators: Include operating instructions.
 - 2. Motors: Show nameplate data, ratings, characteristics, and mounting arrangements
 - 3. Motor controllers.
- B. Shop Drawings: Show location and extent of roller shades. Include elevations, sections, details, and dimensions not shown in Product Data. Show installation details, mountings, attachments to other Work, operational clearances, and relationship to adjoining work
 - 1. Motorized Shade Operators: Show locations and details for installing operator components, switches, and controls. Indicate motor size, electrical characteristics, drive arrangement, mounting, and grounding provisions.
 - 2. Wiring Diagrams: Power, system, and control wiring.
- C. Samples for Verification:
 - 1. Shade Material: Not less than 12-inch- (300-mm-) square section of fabric, from dye lot used for the Work, with specified treatments applied. Show complete pattern repeat. Mark top and face of material.
- D. Window Treatment Schedule: Include roller shades in schedule using same room designations indicated on Drawings.

1.3 INFORMATIONAL SUBMITTALS

- A. Maintenance Data: For roller shades to include in maintenance manuals. Include the following:
 - 1. Methods for maintaining roller shades and finishes.

2. Precautions about cleaning materials and methods that could be detrimental to fabrics, finishes, and performance.
3. Operating hardware.
4. Motorized shade operator.
5. Motor controllers.

1.4 QUALITY ASSURANCE

- A. Installer Qualifications: An experienced installer who has completed installation of roller shades similar in material, design, and extent to that indicated for this Project and whose work has resulted in construction with a record of successful in-service performance
- B. Source Limitations: Obtain roller shades through one source from a single manufacturer.
- C. Fire-Test-Response Characteristics: Provide roller shade band materials with the fire-test-response characteristics indicated, as determined by testing identical products per test method indicated below by UL or another testing and inspecting agency acceptable to authorities having jurisdiction:
 1. Flame-Resistance Ratings: Passes NFPA 701.
- D. Electrical Components, Devices, and Accessories: Listed and labeled as defined in NFPA 70, Article 100, by a testing agency acceptable to authorities having jurisdiction, and marked for intended use.
- E. Mockups: Build mockups to verify selections made under sample submittals and to demonstrate aesthetic effects and qualities of materials and execution.
 1. Build mockups of in-place full-size window shade unit in the location as directed by Architect.
 2. Provide one mock-up for each type of window shade fabric and shade configuration (dual and single shades) provided in the Work.
 3. Approved mockups may become part of the completed Work if undisturbed at time of Substantial Completion.

1.5 DELIVERY, STORAGE, AND HANDLING

- A. Deliver shades in factory packages, marked with manufacturer and product name, fire-test-response characteristics, and location of installation using same room designations indicated on Drawings and in a window treatment schedule.

1.6 PROJECT CONDITIONS

- A. Environmental Limitations: Do not install roller shades until construction and wet and dirty finish work in spaces, including painting, is complete and ambient temperature and humidity conditions are maintained at the levels indicated for Project when occupied for its intended use.

- B. Field Measurements: Where roller shades are indicated to fit to other construction, verify dimensions of other construction by field measurements before fabrication and indicate measurements on Shop Drawings. Allow clearances for operable glazed units' operation hardware throughout the entire operating range.

1.7 WARRANTY

- A. Motorized Roller Shade Hardware, and Shadecloth: Manufacturer's standard non-depreciating twenty-five year limited warranty.
- B. Roller Shade Motors and Motor Control Systems: Manufacturer's standard non-depreciating five-year warranty

PART 2 - PRODUCTS MANUFACTURERS

- A. Basis of Design Manufacturer: Provide specified shade systems by Draper Shade & Screen Co., Inc. or equivalent by one of the following:
 - 1. MechoShade System, Inc.
 - 2. Hunter Douglas Window Fashions.
 - 3. Levolor Contract; a Newell Company; Joanna
 - 4. Silent Gliss USA, Inc
- B. Provide motor controller and keypad by Somfy or equal.

2.2 BASIS OF DESIGN PRODUCTS

- A. Manual Double-Roll Shades: Provide Clutch-Operated FlexShade by Draper or equal.
- B. Manual Single-Roll Shades: Provide Clutch-Operated FlexShade NEXD by Draper or equal
- C. Motorized Single-Roll Shades: Provide Motorized FlexShade AC by Draper or equal.

2.3 MATERIALS

- A. Glare Control Fabric, 1% Open Mesh Type: 2 x 2 basketweave fabric style fabricated from 36% fiberglass & 64% vinyl, .020 inches thick; provide Mermet E-Screen or equal.
 - 1. Color: 007001 Pearl Grey
- B. Room Darkening Fabric, Opaque Type: Opaque fabric style fabricated from 100% polyester with acrylic flocked backing (PVC-Free), .030 inches thick; provide Phifer SheerWeave SW7000 or equal.
 - 1. Color: V41 Canyon.
- C. Brackets: Plated steel, with adequate projection to clear all window fixtures

- D. Aluminum Extrusions: Alloy and temper recommended by manufacturer for use intended and as required for proper application of finish indicated but not less than the strength and durability properties specified in ASTM B 221 for 6063-T5.

2.4 FABRICATION

- A. Product Description: Roller shade consisting of a roller, a means of supporting the roller, a flexible sheet or band of material carried by the roller, a means of attaching the material to the roller, a bottom bar, and an operating mechanism that lifts and lowers the shade
- B. Components: Noncorrosive, self-lubricating materials.
- C. Rollers: Electrogalvanized or epoxy primed steel or extruded-aluminum tube of diameter and wall thickness required to support and fit internal components of operating system and the weight and width of shade band material without sagging; designed to be easily removable from support brackets; with manufacturer's standard method for attaching shade material.
- D. Direction of Roll: Regular, from back of roller.
- E. Mounting Brackets:
 - 1. Dual Roll Shades: Galvanized or zinc-plated steel, specially designed for mounting two rollers on a single bracket with fascia.
 - 2. Single Roll Shades: Galvanized or zinc-plated steel, style for between jamb mounting unless otherwise indicated.
- F. Fascia: L-shaped, formed-steel sheet or extruded aluminum; long edges returned or rolled; continuous panel concealing front and bottom of shade roller, brackets, and operating hardware and operators; length as required for between the jambs mounting; removable design for access
- G. Bottom Bar: Steel or extruded aluminum, with plastic or metal capped ends. Provide concealed, by pocket of shade material, internal-type bottom bar with concealed weight bar as required for smooth, properly balanced shade operation..
- H. Light-Blocking Shade Hardware: Designed for eliminating all visible light gaps when shades are fully closed; manufacturer's standard side channels and perimeter seals, including sill light seal attached to bottom bar, for eliminating light gaps when shades are closed.
 - 1. Provide Exposed LightSeal Hem Bar with soft vinyl welt at bottom in lieu of sill channel for all blackout shades.
 - 2. For dual-shade system, provide for the shade mounted closest to the glass or wall only.
- I. Manual Shade Operation: Bead chain clutch operator.

1. Bead Chain Material: #10 stainless steel chain with 120 lb. breaking strength.
 2. Operator Location: On left or right side of shade as directed by Architect for each location.
- J. Shade Units: Obtain units fabricated in sizes to fill window and other openings as follows, measured at 74 deg F (23 deg C):
1. Shade Units Installed between (Inside) Jambs: Edge of shade not more than 1/4 inch (6 mm) from face of jamb. Length equal to head to sill dimension of opening in which each shade is installed.
 2. Shade Units Installed Outside Jambs: Width and length as indicated, with terminations between shades of end-to-end installations at centerlines of mullion or other defined vertical separations between openings.
- K. Installation Fasteners: Fabricated from metal that is noncorrosive to shade hardware and adjoining construction and to support shades as required by manufacturer's written instructions.
- L. Color-Coated Finish: For metal components exposed to view, apply manufacturer's standard baked finish complying with manufacturer's written instructions for surface preparation including pretreatment, application, baking, and minimum dry film thickness.
- M. Colors of Metal and Plastic Components Exposed to View: As selected by Architect from manufacturer's full range unless otherwise indicated.

2.5 MOTORIZED ROLLER SHADE OPERATORS

- A. General: Provide factory-assembled motorized shade operation systems designed for lifting shades of type, size, weight, construction, use, and operation frequency indicated. Provide operation systems of size and capacity and with features, characteristics, and accessories suitable for Project conditions and recommended by shade manufacturer, complete with electric motors and factory-prewired motor controls, remote-control stations, remote-control devices, power disconnect switches, enclosures protecting controls and all operating parts, and accessories required for reliable operation without malfunction. Include wiring from motor controls to motors. Coordinate operator wiring requirements and electrical characteristics with the building electrical system.
- B. Comply with NFPA 70.
- C. Control Equipment: Comply with NEMA ICS 1, NEMA ICS 2, and NEMA ICS 6 with NFPA 70 Class 2 control circuit, maximum 24-V ac or dc
- D. Electric Motors: UL-approved or -recognized, asynchronous, totally enclosed, insulated, capacitor-start motors, complying with NEMA MG 1, with thermal overload protection, brake, permanently lubricated bearings, and limit switches; sized by shade manufacturer to start and operate size and weight of shade considering service factor or considering Project's service conditions without exceeding nameplate ratings.
1. Service Factor: According to NEMA MG 1, unless otherwise indicated.

2. Motor Characteristics: Single phase, 120 V, 60 Hz.
 3. Motor Mounting: Within manufacturer's standard roller enclosure.
- E. Motor Control System: Shades shall be operated by a control panel on the wall; location as indicated.
1. Provide individual group control motor controller and dry contact keypad by Somfy as specified on the electrical Drawings.
- F. Remote Controls: Electric controls with NEMA ICS 6, Type 1 enclosure for recessed or flush mounting. Provide the following devices for remote-control activation of shades:
1. Control Stations: Push button-operated wall-mounted controls to provide simultaneous raising and lowering of gangs of shades
 - a. Color: As selected by Architect.
 2. Connect local wall switches to motor control system.
- G. Limit Switches: Adjustable switches, interlocked with motor controls and set to automatically stop shade at fully raised and fully lowered positions.
- H. Operating Function: Stop and hold shade at any position

PART 3 - EXECUTION

3.1 EXAMINATION

- A. Examine substrates, areas, and conditions, with Installer present, for compliance with requirements for installation tolerances, operational clearances, accurate locations of connections to building electrical system, and other conditions affecting performance. Proceed with installation only after unsatisfactory conditions have been corrected

3.2 ROLLER SHADE INSTALLATION

- A. Install roller shades level, plumb, square, and true according to manufacturer's written instructions, and located so shade band is not closer than 2 inches (50 mm) to interior face of glass. Allow clearances for window operation hardware.
- B. Install metal parts isolated from concrete or mortar to prevent corrosion.
- C. Install mounting brackets with not less than 2 fasteners per bracket.
- D. Connections: Connect motorized operators to building electrical system.
- E. Coordinate installation of roller shades with placement of interior sign on wall adjacent to rescue windows so that the rescue window is clearly indicated from the interior in the event that the shade is closed.

3.3 ADJUSTING

- A. Adjust and balance roller shades to operate smoothly, easily, safely, and free from binding or malfunction throughout entire operational range.

3.4 CLEANING AND PROTECTION

- A. Clean roller shade surfaces after installation, according to manufacturer's written instructions.
- B. Provide final protection and maintain conditions, in a manner acceptable to manufacturer and Installer, that ensure that roller shades are without damage or deterioration at time of Substantial Completion.
- C. Replace damaged roller shades that cannot be repaired, in a manner approved by Architect, before time of Substantial Completion.

3.5 DEMONSTRATION

- A. Startup Services: Engage a factory-authorized service representative to perform startup services on motor control system and to train Owner's maintenance personnel as specified below:
 - 1. Test and adjust controls and procedures of operation. Replace damaged and malfunctioning controls and equipment.
 - 2. Train Owner's maintenance personnel on procedures and schedules related to startup and shutdown, troubleshooting, reprogramming, and procedures for testing and resetting motor control system.
 - 3. Schedule training with Owner with at least 7 days' advance notice.

3.6 SHADE TYPES SCHEDULE

- A. Refer to Window Shade Types Schedule following this section.

END OF SECTION 122413

WINDOW SHADE TYPES-All dimensions to be verified in the field. Provide valences for all. Include rescue window signage as req'd. (See Dwg. A530 and specification for signage.)					
TYPE #	SHADE	SHADE TYPES	CONTROLS	LENGTH	LOCATION
TYPE 1	Single	Blackout	Motorized	10' - 4"	EXT: Corner Cafeteria
TYPE 2	Single	Blackout	Motorized	5' - 8"	EXT: Corner Cafeteria
TYPE 3	Double	1% and Blackout	Manual	10' - 0"	EXT: 1F Window (Principal & Security 102a)
TYPE 4	Double	1% and Blackout	Manual	8' - 8"	EXT: 1C Window (Pre-K)
TYPE 5	Double	1% and Blackout	Manual	5' - 6"	EXT: 1D & 1E Windows (Pre-K Windows only. See Type 6 for Door Shade)
TYPE 6	Single	Blackout	Manual	2' - 0"	EXT: 1D & 1E Doors (Pre-K exterior door only. See Type 5 for Window Shade)
TYPE 7	Double	1% and Blackout	Manual	4' - 8"	EXT: 1T Window (Faculty)
TYPE 8	Double	1% and Blackout	Manual	2' - 8"	EXT: 1B, 2B, & 3B Windows
TYPE 9	Double	1% and Blackout	Manual	6' - 0"	EXT: Gym Security
TYPE 10	Single	1%	Manual	10' - 4"	EXT: Corner
TYPE 11	Single	1%	Manual	10' - 0"	EXT: Grids 11-15
TYPE 12	Single	1%	Manual	8' - 8"	EXT: Typical
TYPE 13	Single	1%	Manual	6' - 0"	EXT: 2L - 4L Windows
TYPE 14	Single	1%	Manual	5' - 8"	EXT: Corner
TYPE 15	Single	1%	Manual	3' - 0"	INT: Conference Room
TYPE 16	Single	1%	Manual	3' - 10"	INT: A.P. Office

SECTION 123553.19 - WOOD LABORATORY CASEWORK

PART 1 - GENERAL

1.1 SUMMARY

A. Section Includes:

1. Wood laboratory casework.
2. Student science tables
3. Teachers demonstration table
4. Filler and closure panels.
5. Laboratory countertops.
6. Shelves.
7. Storage units, including storage units in Classrooms.
8. Safety eye wash.
9. Accessories.

1.2 DEFINITIONS

A. MDF: Medium-density fiberboard.

B. Exposed Surfaces of Casework: Surfaces visible when doors and drawers are closed, including bottoms of cabinets more than 48 inches (1200 mm) above floor, and visible surfaces in open cabinets or behind glass doors.

1. Ends of cabinets, including those installed directly against walls or other cabinets, are defined as "exposed."
2. Ends of cabinets indicated to be installed directly against and completely concealed by walls or other cabinets are defined as "concealed."

C. Semiexposed Surfaces of Casework: Surfaces behind opaque doors, such as cabinet interiors, shelves, and dividers; interiors and sides of drawers; and interior faces of doors. Tops of cabinets 78 inches (1980 mm) or more above floor are defined as "semiexposed."

D. Concealed Surfaces of Casework: Include sleepers, web frames, dust panels, and other surfaces not usually visible after installation.

E. Hardwood Plywood: A panel product composed of layers or plies of veneer, or of veneers in combination with lumber core, hardboard core, MDF core, or particleboard core, joined with adhesive and faced both front and back with hardwood veneers.

1.3 SUBMITTALS

A. Product Data: For each type of product indicated.

B. Shop Drawings: For laboratory casework. Include plans, elevations, sections, details, and attachments to other work.

1. Indicate locations of hardware and keying of locks.
 2. Indicate locations and types of service fittings.
 3. Indicate locations of blocking and reinforcements required for installing laboratory casework..
 4. Include details of exposed conduits, if required, for service fittings.
 5. Indicate locations of and clearances from adjacent walls, doors, windows, other building components, and other laboratory equipment.
 6. Include coordinated dimensions for laboratory equipment specified in other Sections.
- C. Samples for Initial Selection: For factory-applied finishes and other materials requiring color selection.
- D. Samples for Verification: For each type of cabinet finish and each type of countertop material indicated, in manufacturer's standard sizes.
- E. Qualification Data: For qualified manufacturer.
- F. Product Test Reports for Casework: Based on evaluation of comprehensive tests performed by a qualified testing agency, indicating compliance of laboratory casework with requirements of specified product standard.
- G. Product Test Reports for Countertop Surface Material: Based on evaluation of comprehensive tests performed by a qualified testing agency, indicating compliance of laboratory countertop surface materials with requirements specified for chemical and physical resistance.
- 1.4 QUALITY ASSURANCE
- A. Manufacturer Qualifications: A qualified manufacturer that produces casework of types indicated for this Project that has been tested for compliance with SEFA 8.
- B. Source Limitations: Obtain laboratory casework from single source from single manufacturer unless otherwise indicated.
1. Obtain countertops, sinks, accessories and fittings from casework manufacturer.
- C. Product Designations: Drawings indicate sizes and configurations of laboratory casework by referencing designated manufacturer's catalog numbers. Other manufacturers' laboratory casework of similar sizes and similar door and drawer configurations and complying with the Specifications may be considered. Refer to Division 01 Section "Product Requirements."
- D. Casework Product Standard: Comply with SEFA 8, "Laboratory Furniture - Casework, Shelving and Tables - Recommended Practices."
- E. Keying Conference: Conduct conference at project site. Incorporate keying conference decisions into final keying requirements

1.5 DELIVERY, STORAGE, AND HANDLING

- A. Protect finished surfaces during handling and installation with protective covering of polyethylene film or other suitable material.

1.6 PROJECT CONDITIONS

- A. Environmental Limitations: Do not deliver or install laboratory casework until building is enclosed, utility roughing-in and wet work are complete and dry, and temporary HVAC system is operating and maintaining temperature and relative humidity at occupancy levels during the remainder of the construction period.

1.7 COORDINATION

- A. Coordinate layout and installation of framing and reinforcements for support of laboratory casework.

PART 2 - PRODUCTS

2.1 WOOD CABINET MATERIALS

- A. General: All exterior surfaces exposed to view after installation, and all cabinet interior surfaces shall be White Maple with the exception of back panels behind opaque doors which shall be Hardboard, and drawer boxes which shall be Birch.
- B. Solid Wood:
 - 1. Exposed Solid Wood: Plain sawn White Maple lumber, Grade FAS or better, clear and free of defects. Lumber shall be air dried, then kiln dried, and tempered to a moisture content of 6%-9% before use.
 - 2. Unexposed Solid Wood: Other hardwoods may be used that are Grade FAS or better, clear and free of defects, and properly dried in same manner as exposed solid wood.
- C. Plywood:
 - 1. All plywood panels with veneer core, particleboard core or MDF core shall be CARB Phase 2 Compliant.
 - 2. Hardwood Veneer Core Plywood shall be minimum 3-ply (1/4"), 5-ply (1/2"), or 7-ply (3/4") with select White Maple, Grade B-2, plain sliced, book match, veneer face and back, and shall be compliant with ANSI/HPVA HP-1 2009. All 9-ply (1") plywood shall be Grade B-2, whole piece, rotary cut, maple veneer face and back. Use of other hardwood face veneer shall be acceptable in unexposed areas. Combination core with composite cross bands shall be acceptable in lieu of veneer core.
 - 3. Composite Core Plywood for cabinet drawer fronts and panel doors shall be 3-ply, 3/4" thick with select White Maple Grade B-2, plain sliced, slip match veneer, and shall be compliant with ANSI A208.1-2009 (PBC) or ANSI A208.2-2009 (MDF).

- D. Banding: Plywood panels shall be edge banded where specified with 3mm solid Maple edge band.
- E. Hardboard: Tempered hardboard shall be 1/4" thick. All hardboard shall be composed of wood fibers and resinous binder compressed under heat and pressure.

2.2 AUXILIARY CABINET MATERIALS

- A. Glass for Glazed Doors: Clear tempered glass complying with ASTM C 1048, Kind FT, Condition A, Type I, Class 1, Quality-Q3; not less than 1/8" thick for framed doors (1/4" at tall cabinets), and 1/4" for frameless sliding doors.

2.3 COUNTERTOP AND SINK MATERIALS

- A. Epoxy: Factory-molded, modified epoxy-resin formulation with smooth, nonspecular finish.
 - 1. Basis of Design Product: Shelresin by Sheldon or equal products of one of the following:
 - a. Durcon.
 - b. Prime Industries, Inc.
 - 2. Physical Properties:
 - a. Flexural Strength: Not less than 10,000 psi (70 MPa).
 - b. Modulus of Elasticity: Not less than 2,000,000 psi (1400 MPa).
 - c. Hardness (Rockwell M): Not less than 100.
 - d. Water Absorption (24 Hours): Not more than 0.02 percent.
 - e. Heat Distortion Point: Not less than 260 deg F (127 deg C).
 - 3. Chemical Resistance: Epoxy-resin material has the following ratings when tested with indicated reagents according to NEMA LD 3, Test Procedure 3.4.5:
 - a. No Effect: Acetic acid (98 percent), acetone, ammonium hydroxide (28 percent), benzene, carbon tetrachloride, dimethyl formamide, ethyl acetate, ethyl alcohol, ethyl ether, methyl alcohol, nitric acid (70 percent), phenol, sulfuric acid (60 percent), and toluene.
 - b. Slight Effect: Chromic acid (60 percent) and sodium hydroxide (50 percent).
 - 4. Color: Black.

2.4 WOOD CABINETS

- A. Basis-of-Design Product: Subject to compliance with requirements, provide "Classic Series" laboratory casework and storage units and "Classic Designer Series" student science tables manufactured by Sheldon Laboratory Systems or comparable product by one of the following:
 - 1. ICIScientific, ICICampbellRhea Educational Wood
 - 2. Kewaunee Scientific Corporation

- B. Design: Partial overlay casework with drawers and doors designed with square edge with slight radius with vertical match grain fronts and Maple edge band.
- C. Grain Direction:
 - 1. Vertical on doors and drawer fronts.
 - 2. Lengthwise on face frame members.
 - 3. Vertical on end panels.
 - 4. Side to side on bottoms and tops of units.
 - 5. Vertical on knee-space panels.
 - 6. Horizontal on aprons and table frames.
- D. Veneer Matching: Drawer fronts and panel doors on each cabinet shall be cut from one (1) Maple composite core plywood panel as a matching front set, using plain sliced, slip match veneer.
- E. Construction: Provide wood-faced laboratory casework of the following minimum construction:
 - 1. Bottoms of Base Cabinets and Tall Cabinets: 3/4-inch- thick veneer-core hardwood plywood.
 - 2. Tops and Bottoms of Wall Cabinets and Tops of Tall Cabinets: 1-inch-thick veneer-core hardwood plywood.
 - 3. Ends of Cabinets and Vertical Partitions: 3/4-inch- thick veneer-core hardwood plywood.
 - 4. Shelves: 1-inch- thick veneer-core hardwood plywood. Shelves shall be adjustable on 32mm centers, supported by four (4) nickel-plated steel pin and socket type shelf clips.
 - 5. Exposed or semi-exposed edges of end panels, top and bottom panels, partitions, and shelves shall be edged with 3mm solid Maple edge banding
 - 6. Base Cabinet Top Frames: 1-by-3-inch solid wood front rail and back rail with mortise and tenon or doweled connections, glued and pinned or screwed.
 - a. Cross rails for top frames shall be 1" X 2-1/4" solid hardwood fully housed into front and back rails with tongue and groove joints to form a full four-sided top frame.
 - 7. Back Rails:
 - a. Wall Cabinets: Top and bottom back rail shall be 4" x 3/4" hardwood veneer core plywood doweled and glued into end panels, and used for attaching the cabinet to wall.
 - b. Tall Cabinets: Top back rail and center back rail shall be 3" x 1" solid hardwood and bottom back rail shall be 4" x 3/4" hardwood veneer core plywood; all rails shall be doweled and glued into end panels.
 - 8. Base Cabinets Intermediate Rails: Provide on all base cabinets between drawer/drawer configurations and drawer/door configurations. Rails shall be 1" X 3" solid Maple with back grooved to receive lock security panels (when panels are provided). Rails shall be set flush with cabinet ends, doweled and glued into place

9. Recessed Bottom Front Toe Rail for Base Cabinets and Tall Cabinets: 4" x 3/4" Maple veneer core plywood doweled and glued into end panels.
10. Backs of Cabinets: 1/4-inch- thick, hardwood plywood where exposed, 1/4-inch-thick hardboard dadoed into sides, bottoms, and tops where not exposed.
11. Drawer Fronts: 3/4-inch- thick, composite core plywood.
12. Drawer Box Body:
 - a. Front, sides, and back shall be 1/2" thick 9-ply Birch plywood with dovetail joinery all four (4) corners.
 - b. Bottom shall be 1/4" thick white finished hardboard set in grooves on four (4) sides and hot-melt glued on underside.
 - c. Drawer box shall have clear chemical resistant finish.
 - d. Top edge of box shall have a finished top cap to conceal edge of veneer core.
13. Doors: 3/4 inch thick composite core plywood.
14. Stiles and Rails of Glazed Doors:
 - a. 3/4" x 3" solid Maple top, bottom, and side rails, doweled and glued together, sanded for smooth fit, and edge detailed with a slight radius.
 - b. Tall Cabinet doors shall have a 3/4" x 6" wide solid Maple center rail.

- F. Filler and Closure Panels: Provide where indicated and as needed to close spaces between cabinets and walls, ceilings, and indicated equipment. Fabricate from same material and with same finish as adjacent exposed cabinet surfaces unless otherwise indicated.

2.5 STUDENT TABLES

A. Utility Tables (Student Tables):

1. Tables shall be fully framed with 3/4" x 4" radius edged solid Maple apron rails with diagonal heavy-duty steel corner braces locked into grooves and screwed with four (4) screws to inner face of rails. Intermediate rails shall be solid hardwood.
2. Table legs shall be properly fitted into position and securely fastened to diagonal corner braces with nut, washer and 3-1/2" x 5/16" carriage bolt, completely running through the leg providing a positive system, whereby bolt can be tightened without depending upon screw holding power of the table legs. Legs shall be 2-1/4" square laminated solid Maple, thoroughly glued, and radius edged. Legs shall be equipped with rubber leg shoes, and adjustable nylon glides.
3. Provide locking casters for table legs.

- B. Adjustable Height Two-Student Table (ADA Tables): Provide adjustable height utility table as scheduled.

2.6 WOOD FINISH

- A. Preparation: Sand lumber and plywood before assembling. Sand edges of doors, drawer fronts, and molded shapes with profile-edge sander. Sand after assembling for uniform smoothness at least equivalent to that produced by 220-grit sanding and without machine marks, cross sanding, or other surface blemishes.

- B. Staining: Remove fibers and dust and apply stain to exposed and semiexposed surfaces as necessary to match approved Samples. Apply stain in a manner that will produce a consistent appearance. Apply wash-coat sealer before applying stain to closed-grain wood species.
 - 1. Stain Color for Storage Units and Laboratory Casework: Authentic Maple.
 - 2. Stain Color for Student Science Tables: Solid color stain in Grizzley Grey.
- C. Chemical-Resistant Finish: Apply laboratory casework manufacturer's standard two-coat, chemical-resistant, transparent finish. Sand and wipe clean between coats. Topcoat(s) may be omitted on concealed surfaces.
 - 1. Chemical and Physical Resistance of Finish System: Finish complies with acceptance levels of cabinet surface finish tests in SEFA 8. Acceptance level for chemical spot test shall be no more than three Level 3 conditions.

2.7 HARDWARE

- A. General: Provide laboratory casework manufacturer's standard, commercial-quality, heavy-duty hardware complying with requirements indicated for each type.
 - 1. Finish shall be as selected by Architect.
- B. Hinges: Steel, 5-knuckle heavy-duty institutional hinges complying with BHMA A156.9, Grade 1, with antifriction bearings and rounded tips. Provide 2 for doors 36 inches high or less and 3 for doors more than 36 inches high.
 - 1. Provide in black powder coated finish.
- C. Pulls: Solid steel wire pulls 4" long, back-mounted with screws. Provide 2 pulls for drawers more than 24 inches wide.
 - 1. Provide in black powder coated finish.
- D. Door Catches: Magnetic self-aligning catches, heavy duty. Provide 2 catches per door
- E. Elbow Catches: Brass with latch held by coiled compressing spring and catch plates of 16-gauge plated steel. Provide on base and wall cabinets with double doors where locks are specified.
- F. Drawer Slides: Shall be easily removable, have a 100 lb. dynamic load rating, and have self-closing, 3/4 extension, epoxy powder coated steel, nylon rollers, bottom mount, positive stop features. File drawers shall have full extension, zinc plated anochrome finish, ball bearing, side mount slides with lever release.
- G. Spring Actuated Latch: Latch has 4-5/8" bevel slide bolt with 2-1/4 lbs./in. actuating spring. Provide on tall cabinets with double doors where locks are specified.
- H. Leg Shoes: Molded vinyl or rubber, black, coved bottom type.

- I. Drawer and Cupboard Locks: Laboratory grade, cylinder cam locks, with 5-disc tumbler mechanism, and a dull chrome-plated face. Tumblers and keys shall be brass, with plug and cylinder of die cast zinc alloy. Locks shall be equipped with RemovaCore™ keying control (With the use of a control key, the key core of the lock assembly can be removed, and a new key core inserted, changing the entire locking system).
 - 1. Provide a minimum of two keys per lock and six master keys. All locks within a room shall be keyed alike with a single master.
 - 2. Provide locks for all doors and drawers.
- J. Label Holders: Stainless steel, aluminum, or chrome plated; sized to receive standard label cards approximately 1 by 2 inches (25 by 50 mm), attached with screws or rivets. Provide where indicated.
- K. Sliding-Door Hardware Sets: Laboratory casework manufacturer's standard, to suit type and size of sliding-door units.
- L. Adjustable Shelf Supports for Wood Cabinets: Powder-coated steel shelf rests complying with BHMA A156.9, Type B04013.
- M. Adjustable Wall Shelf Supports: Surface-type steel standards and steel shelf brackets, with epoxy powder-coated finish, complying with BHMA A156.9, Types B04102 and B04112.

2.8 COUNTERTOPS

- A. Countertops, General: Provide units with smooth surfaces in uniform plane free of defects. Make exposed edges and corners straight and uniformly beveled. Provide front and end overhang of 1 inch (25 mm), with continuous drip groove on underside 1/2 inch (13 mm) from edge.
- B. Epoxy Countertops:
 - 1. Countertop Fabrication: Fabricate with factory cutouts for sinks, holes for service fittings and accessories, and with butt joints assembled with epoxy adhesive and concealed metal splines.
 - a. Countertop Configuration: Flat, 1 inch (25 mm) thick, with beveled edge and corners, and with drip groove and applied 4" high back and end splashes.
 - b. Countertop Construction: Uniform throughout full thickness.

2.9 TEACHERS DEMONSTRATION TABLE

- A. Sheldon 20696 ADA Instructor Demonstration Center: 96" l. x 31" w. X 33" H. Sink on Left End.
 - 1. Demonstration Center: Includes one (1) S343228-000 ADA sink cabinet with removable panel, one (1) B303228-560 six-drawer cabinet, one (1) ADA kneespace,

and a finished back. The Center also includes a black Shelresin top with epoxy resin ADA drop-in sink on left end. Internal service piping and wiring not included.

2. Standard services and accessories included:
 - a. One (1) 80030 Unimix hot and cold water fixture with wrist blade handle and check valves.
 - b. One (1) A25 Shelresin 18" x 15" x 5" I.D. drop-in sink.
 - c. One (1) sink outlet, strainer and stopper.
 - d. One (1) 85101 GFI duplex electrical outlet.
 - e. One (1) 86380 upright rod assembly with two (2) 86320 rod bases.

2.10 SAFETY GLASSES CABINET

- A. Sheldon 31170 Safety Glasses Cabinet: 32"H. x 24 1/2"W. x 9 1/2"D. Overall. 24-gauge white enameled steel cabinet, doors interlocked with tamper resistant latches, two keys provided for each unit. Wall or shelf mountable with a 7' (2.13 m) grounded electrical cord.
- B. Shuts off automatically if double doors are open. Pilot light confirms UV lamp in use. Five minute cycle controlled by a timer, and no direct UV radiation escapes from cabinet when in use. Unit includes eight (8) removable wire racks, each rack accommodating up to six (6) pairs of glasses or five (5) pairs of goggles. (Glasses and goggles not included.)

2.11 ACID/FLAMMABLE STORAGE CABINET

- A. Sheldon SC4236 Acid/Flammable Storage Cabinet: 35" W. x 35 1/2" H. x 22"D. Cabinet is constructed of one inch (1") thick, high-density, 9-ply, exterior grade plywood finished with multiple coats of epoxy paint. Cabinet bottom is constructed as a liquid-tight, two inch (2") trough to contain accidental spills. Interior is fully lined with 1/8" thick polypropylene. Storage cabinet is actually two cabinets in one. Acid side features wooden hinge assembly; polypropylene hasp assembly; 10" corrosive label for easy identification. Flammable side features continuous metal hinge; metal lock assembly; adjustable shelf; 10" flammable label for easy identification. Cabinet complies with all O.S.H.A. and National Fire Protection Association standards.

2.12 SAFETY EYE WASH

- A. Eyewash, Deck Mounted, 90 Degree AutoFlow™ : AutoFlow™ eyewash for mounting next to sink. Water flow is activated by swinging the spray head assembly over the sink.
 1. Construction: Polished chrome plated brass.
 2. Spray Head Assembly: Two GS-Plus™ spray heads. Each head has a "flip top" dust cover, internal flow control and filter to remove impurities from the water flow.
 3. Valve: 1/2" IPS brass plug-type valve with O-ring seals. Swinging spray head assembly from storage to operational position opens orifice and activates water flow. Unit remains in operation until spray head assembly is swung back into the storage position.
 4. Strainer: Unit is furnished with in-line strainer to protect valve and spray heads from debris in water line.
 5. Supply: 1/2" NPT female inlet.
 6. Sign: Furnished with universal identification sign.

7. Mixing Valve: Provide TMV G3600LF thermostatic mixing valve which precisely blends hot and cold water to deliver tepid water as required by ANSI Z358.1-2014.
8. Quality Assurance: Unit is fully assembled and water tested prior to shipment. Unit is third-party certified to comply with ANSI Z358.1-2014.
9. Basis of Design Product: G1805LH (left-hand mounted) by Guardian Equipment, or equal by WaterSaver.

2.13 ACCESSORIES

- A. Glass Drying Rack: Wall-mounted 1" phenolic resin pegboard with removable polypropylene pegs and stainless-steel drip troughs with drain outlet.
 1. Drying Rack: Provide unit with 32 pegs, 20" x 30"; Sheldon Model 79520 or equal.
 2. Drip Trough: Provide unit 20" x 2" x 1", with hose; Sheldon Model MET-511-20 or equal.
- B. Fire Blanket and Cabinet:
 1. Cabinet: Red steel cabinet designed to protect fire blankets from exposure to harsh UV rays, chemicals, moisture, dust, salt air, insects, and temperature extremes. Size: 15" x 15" x 2"
 2. Fire Blanket: 5' x 6' white fiberglass heat resistant blanket used to either cover the fire, cutting off the oxygen supply; or to wrap around a person whose clothes are on fire. Temperature resistance 1000 deg. F
 3. Basis of Design Product: Sellstrom Emergency Fire Blanket by Sheldon Labs, or equal.

PART 3 - EXECUTION

3.1 EXAMINATION

- A. Examine areas, with Installer present, for compliance with requirements for installation tolerances, location of reinforcements, and other conditions affecting performance of laboratory casework.
- B. Proceed with installation only after unsatisfactory conditions have been corrected.

3.2 INSTALLATION OF CABINETS

- A. Comply with installation requirements in SEFA 2.3. Install level, plumb, and true; shim as required, using concealed shims. Where laboratory casework abuts other finished work, apply filler strips and scribe for accurate fit, with fasteners concealed where practical. Do not exceed the following tolerances:
 1. Variation of Tops of Base Cabinets from Level: 1/16 inch in 10 feet (1.5 mm in 3 m).
 2. Variation of Bottoms of Upper Cabinets from Level: 1/8 inch in 10 feet (3 mm in 3 m).

3. Variation of Faces of Cabinets from a True Plane: 1/8 inch in 10 feet (3 mm in 3 m).
 4. Variation of Adjacent Surfaces from a True Plane (Lippage): 1/32 inch (0.8 mm).
 5. Variation in Alignment of Adjacent Door and Drawer Edges: 1/16 inch (1.5 mm).
- B. Base Cabinets: Fasten cabinets to utility-space framing, partition framing, wood blocking, or reinforcements in partitions with fasteners spaced not more than 24 inches (600 mm) o.c. Bolt adjacent cabinets together with joints flush, tight, and uniform.
1. Where base cabinets are installed away from walls, fasten to floor at toe space at not more than 24 inches (600 mm) o.c. and at sides of cabinets with not less than 2 fasteners per side.
- C. Wall Cabinets: Fasten to hanging strips, masonry, partition framing, blocking, or reinforcements in partitions. Fasten each cabinet through back, near top, at not less than 24 inches (600 mm) o.c.
- D. Install hardware uniformly and precisely. Set hinges snug and flat in mortises.
- E. Adjust laboratory casework and hardware so doors and drawers align and operate smoothly without warp or bind and contact points meet accurately. Lubricate operating hardware as recommended by manufacturer.

3.3 INSTALLATION OF COUNTERTOPS

- A. Comply with installation requirements in SEFA 2.3. Abut top and edge surfaces in one true plane with flush hairline joints and with internal supports placed to prevent deflection. Locate joints only where shown on Shop Drawings.
- B. Field Jointing: Where possible, make in same manner as shop-made joints using dowels, splines, fasteners, adhesives, and sealants recommended by manufacturer. Prepare edges in shop for field-made joints.
- C. Fastening:
1. Secure epoxy countertops to cabinets with epoxy cement, applied at each corner and along perimeter edges at not more than 48 inches (1200 mm) o.c.
 2. Where necessary to penetrate countertops with fasteners, countersink heads approximately 1/8 inch (3 mm) and plug hole flush with material equal to countertop in chemical resistance, hardness, and appearance.
- D. Provide required holes and cutouts for service fittings.
- E. Provide scribe moldings for closures at junctures of countertop, curb, and splash with walls as recommended by manufacturer for materials involved. Match materials and finish to adjacent laboratory casework. Use chemical-resistant, permanently elastic sealing compound where recommended by manufacturer.
- F. Carefully dress joints smooth, remove surface scratches, and clean entire surface.

3.4 INSTALLATION OF ACCESSORIES AND EYE WASH

- A. General: Comply with manufacturer's written instructions.
- B. Built-in Equipment: Securely anchor units to supporting construction with concealed fasteners. Verify that clearances are adequate for proper functioning and that rough openings are completely concealed.
- C. Freestanding Equipment: Place units in final locations after finishes have been completed in each area. Verify that clearances are adequate to properly operate equipment.
- D. Utilities: Comply with plumbing and electrical requirements.
- E. Mount equipment as per manufacturer's directions and as required by field conditions.
- F. Adjust moving parts to operate smoothly, easily, properly, and without binding.

3.5 CLEANING AND PROTECTING

- A. Clean finished surfaces, touch up as required, and remove or refinish damaged or soiled areas to match original factory finish, as approved by Architect.
- B. Protect countertop surfaces during construction with 6-mil (0.15-mm) plastic or other suitable water-resistant covering. Tape to underside of countertop at a minimum of 48 inches (1200 mm) o.c.

3.6 SCHEDULE OF LABORATORY CASEWORK AND ACCESSORIES

- A. Refer to Schedule of Casework included in Division 12.

END OF SECTION 123553.19

SECTION 123559 - INSTITUTIONAL CASEWORK

PART 1 - GENERAL

1.1 SUMMARY

- A. This Section includes the following:
 - 1. Musical instrument storage cabinets.
- B. Related Sections include the following:
 - 1. Division 06 Section "Interior Architectural Woodwork" for custom wood and laminate clad casework and plastic laminate countertops.

1.2 SUBMITTALS

- A. Product Data: For each type of product indicated.
- B. Shop Drawings: Show fabrication and installation details for institutional casework. Include plans, elevations, sections, details, and attachments to other Work.
- C. Samples for Verification: 6-inch- (150-mm-) square samples for each type of finish

1.3 QUALITY ASSURANCE

- A. Installer Qualifications: An authorized representative of institutional casework manufacturer for installation and maintenance of units required for this Project.
- B. Source Limitations: Obtain institutional casework, including cabinets and tops, through one source from a single manufacturer.
- C. Product Designations: Drawings indicate sizes, configurations, and finish material of institutional casework by referencing designated manufacturer's catalog numbers. Other manufacturers' casework of similar sizes and door and drawer configurations, of same finish material, and complying with the Specifications may be considered. Refer to Division 01 Section "Product Requirements."

1.4 DELIVERY, STORAGE, AND HANDLING

- A. Deliver institutional casework only after painting, utility roughing-in, and similar operations that could damage, soil, or deteriorate casework have been completed in installation areas. If casework must be stored in other than installation areas, store only in areas where environmental conditions meet requirements specified in "Project Conditions" Article.

- B. Keep finished surfaces covered with polyethylene film or other protective covering during handling and installation.

1.5 PROJECT CONDITIONS

- A. Environmental Limitations: Do not deliver or install institutional casework until building is enclosed, wet work is complete, and HVAC system is operating and maintaining temperature and relative humidity at occupancy levels during the remainder of the construction period.
- B. Field Measurements: Where institutional casework is indicated to fit to other construction, verify dimensions by field measurements before fabrication and indicate measurements on Shop Drawings.
 - 1. Established Dimensions: Where field measurements cannot be made without delaying the Work, establish dimensions and proceed with fabricating institutional casework without field measurements. Coordinate construction to ensure that actual dimensions correspond to established dimensions.

1.6 COORDINATION

- A. Coordinate layout and installation of metal framing and reinforcements in gypsum board assemblies for support of institutional casework.

1.7 WARRANTY

- A. Special Warranty: Manufacturer's standard form in which manufacturer agrees to repair or replace components of institutional casework that fail in materials or workmanship within specified warranty period. Failures include, but are not limited to, the following:
 - 1. Delamination of components or other failures of glue bond.
 - 2. Warping of components.
 - 3. Failure of operating hardware.
 - 4. Deterioration of finishes.
- B. Warranty Period: Ten years from date of Substantial Completion.

PART 2 - PRODUCTS

2.1 MANUFACTURERS

- A. Manufacturers: The design for institutional casework is based on the products of Wenger Corp. Subject to compliance with requirements, provide the named products or a comparable product by one of the following:
 - 1. Marco Group
 - 2. Stevens Industries

2.2 MATERIALS

A. General:

1. Maximum Moisture Content for Lumber: 7 percent for hardwood and 12 percent for softwood.
2. Hardwood Plywood: HPVA HP-1, either veneer core or particle core, unless otherwise indicated.
3. Softwood Plywood: DOC PS 1.
4. Particleboard: ANSI A208.1, Grade M-3i; Minimum 43 lb. density, 3-ply construction.
5. Medium-Density Fiberboard: ANSI A208.2, Grade MD.
6. Hardboard: AHA A135.5, S2S finish.

B. Exposed Cabinet Materials:

1. Polyester Laminate: Manufacturer's standard
 - a. Color: Oyster
2. Edgebanding: Rigid PVC extrusions, through color with satin finish

C. Core Materials: Particleboard.

D. Hardware: Manufacturer's standards.

2.3 MUSICAL STORAGE UNITS FABRICATION

A. Basis of Design Products: UltraStor Adjustable Shelf Musical Storage Units by Wenger Corp., or equal.

B. Musical Instrument Storage Units: Modular instrument storage casework with integral bases, adjustable levelers, and through-bolted fastening, enabling owner reconfiguration of unit layout. Adjustable shelf system shall be integrated into cabinet walls allowing shelf placement at increments common to musical instruments.

1. Height: 68 inches
2. Wall Panels: Thermofused composite wood 3/4" thick in oyster color with polyester laminate finish
3. Shelves: One-piece high molecular blow-molded polyethylene with grooved surfaces and radius front edge. Mounted with self-lock shelf supports.
 - a. Provide 4 adjustable shelves per unit.
4. Edging: 1/8" beveled PVC.
5. Doors: Full length straight grille doors with slide latch and padlock eye. Fabricate doors from bright basic steel wire, 5/16 and 3/16 inch diameter, with full 360 degree welds at T-joints, and powder paint finish in color selected by Architect.
6. Four levelers.

- C. Products: As scheduled in Casework Schedule included in Division 12.

PART 3 - EXECUTION

3.1 EXAMINATION

- A. Examine areas, with Installer present, for compliance with requirements for installation tolerances, location of reinforcements, and other conditions affecting performance of institutional casework.
 - 1. Proceed with installation only after unsatisfactory conditions have been corrected.

3.2 CASEWORK INSTALLATION

- A. Install plumb, level, and true; shim as required, using concealed shims. Where institutional casework abuts other finished work, apply filler strips and scribe for accurate fit, with fasteners concealed where practical.
- B. Cabinets: Set cabinets straight, level, and plumb. Adjust tops within 1/16 inch (1.5 mm) of a single plane. Fasten cabinets to partition framing, wood blocking, or reinforcements in partitions with fasteners spaced 24 inches (600 mm) o.c. Bolt adjacent cabinets together with joints flush, tight, and uniform. Align similar adjoining doors and drawers to a tolerance of 1/16 inch (1.5 mm).

3.3 CLEANING AND PROTECTING

- A. Repair or remove and replace defective work as directed on completion of installation.
- B. Clean finished surfaces, touch up as required, and remove or refinish damaged or soiled areas to match original factory finish, as approved by Architect.

END OF SECTION 123559

SECTION 123661 - SIMULATED STONE COUNTERTOPS

PART 1 - GENERAL

1.1 SUMMARY

- A. This Section includes manufactured composite stone countertops.

1.2 ACTION SUBMITTALS

- A. Product Data: For the following:
 - 1. Each variety of composite stone
 - 2. Stone accessories and other manufactured products.
- B. Shop Drawings: Include plans, sections, details, and attachments to other work.
- C. Samples for Verification: For each composite stone color and pattern indicated, in sets of samples not less than 12 inches (300 mm) square. Include two or more Samples in each set and show the full range of variations in appearance characteristics expected in completed Work.

1.3 INFORMATIONAL SUBMITTALS

- A. Qualification Data: For fabricator.
- B. Sealant Compatibility Test Report: From sealant manufacturer, complying with requirements in Division 07 Section "Joint Sealants" and indicating that sealants will not stain or damage stone.
- C. Maintenance Data: For composite stone countertops to include in maintenance manuals. Include Product Data for stone-care products used or recommended by Installer, and names, addresses, and telephone numbers of local sources for products.

1.4 QUALITY ASSURANCE

- A. Fabricator Qualifications: Shop that employs skilled workers who custom-fabricate composite stone countertops similar to that indicated for this Project and whose products have a record of successful in-service performance.
- B. Installer Qualifications: Fabricator of products.
- C. Source Limitations: Obtain each variety of composite stone from a single manufacturer with resources to provide materials of consistent quality in appearance and physical properties.

1.5 DELIVERY, STORAGE, AND HANDLING

- A. Store composite stone on wood A-frames or pallets with nonstaining separators and nonstaining, waterproof covers. Ventilate under covers to prevent condensation.

1.6 PROJECT CONDITIONS

- A. Field Measurements: Verify dimensions of construction to receive composite stone countertops by field measurements before fabrication

PART 2 - PRODUCTS

2.1 COMPOSITE STONE

- A. Composite Stone Material: Composite material of natural quartz, polymer resins and pigments.
 - 1. Basis of Design Product: Wilsonart Quartz or equal by one of the following:
 - a. ColorQuartz
 - b. Cosentino
 - c. DuPont
 - 2. Thickness: 3 cm
 - 3. Colors: As scheduled on the Millwork Schedule in Division 06.
 - 4. Finish: Polished.
 - 5. Edges: Eased
 - 6. Flame Spread: Class A.

2.2 ADHESIVES, GROUT, SEALANTS, AND STONE ACCESSORIES

- A. General: Use only adhesives formulated for composite stone and recommended by their manufacturer for the application indicated. Use adhesives that have a VOC content of not more than 50 g/L when calculated according to 40 CFR 59, Subpart D (EPA Method 24).
- B. Water-Cleanable Epoxy Adhesive: ANSI A118.3.
 - 1. Available Manufacturers: Subject to compliance with requirements, products that may be incorporated into the Work include, but are not limited to, the following:
 - a. Laticrete International, Inc.
 - b. MAPEI Corp.
- C. Sealant for Countertops: Manufacturer's standard sealant of characteristics indicated below that comply with applicable requirements in Division 07 Section "Joint Sealants" and will not stain the composite stone it is applied to.
 - 1. DAP, as recommended by countertop manufacturer.
 - 2. Color: As selected by Architect from manufacturer's full range.

- D. Cleaner: Cleaner specifically formulated for composite stone types, finishes, and applications indicated, as recommended by composite stone producer and, if a sealer is specified, by sealer manufacturer. Do not use cleaning compounds containing acids, caustics, harsh fillers, or abrasives.

2.3 FABRICATION, GENERAL

- A. Fabricate composite stone countertops in sizes and shapes required to comply with requirements indicated, including details on Drawings and Shop Drawings.
 - 1. Dress joints straight and at right angle to face, unless otherwise indicated.
 - 2. Cut and drill sinkages and holes in composite stone for anchors, supports, and attachments.
 - 3. Provide openings, reveals, and similar features as needed to accommodate adjacent work.
 - 4. Fabricate molded edges with machines having abrasive shaping wheels made to reverse contour of edge profile to produce uniform shape throughout entire length of edge and with precisely formed arris slightly eased to prevent snipping, and matched at joints between units. Form corners of molded edges as indicated with outside corners slightly eased, unless otherwise indicated.
 - 5. Finish exposed faces of composite stone to comply with requirements indicated for finish of each type of composite stone required and to match approved Samples and mockups. Provide matching finish on exposed edges of countertops, splashes, and cutouts.
- B. Carefully inspect finished composite stone units at fabrication plant for compliance with requirements for appearance, material, and fabrication. Replace defective units.

2.4 COUNTERTOPS

- A. Nominal Thickness: Provide thickness indicated.
- B. Edge Detail: As indicated.
- C. Joints: Fabricate countertops without joints, to greatest extent possible. Where not possible fabricate countertops in sections for joining in field, with joints at locations indicated and as follows:
 - 1. Sealant-Filled Joints: 1/16 inch (1.5 mm) in width.

PART 3 - EXECUTION

3.1 EXAMINATION

- A. Examine substrates indicated to receive composite stone countertops and conditions under which composite stone countertops will be installed, with Installer present, for compliance with requirements for installation tolerances and other conditions affecting performance.

1. For the record, prepare written report, endorsed by Installer, listing conditions detrimental to performance of composite stone countertops.
2. Proceed with installation only after unsatisfactory conditions have been corrected.

3.2 PREPARATION

- A. Advise installers of other work about specific requirements for placement of inserts and similar items to be used by composite stone countertop Installer for anchoring composite stone countertops. Furnish installers of other work with Drawings or templates showing locations of these items.

3.3 CONSTRUCTION TOLERANCES

- A. Variation from Plumb: For vertical lines and surfaces, do not exceed 1/16 inch in 48 inches (1.5 mm in 1200 mm).
- B. Variation from Level: Do not exceed 1/8 inch in 96 inches (3 mm in 2400 mm), 1/4 inch (6 mm) maximum.
- C. Variation in Joint Width: Do not vary joint thickness more than 1/4 of nominal joint width.
- D. Variation in Plane at Joints (Lipping): Do not exceed 1/64-inch (0.4-mm) difference between planes of adjacent units.
- E. Variation in Line of Edge at Joints (Lipping): Do not exceed 1/64-inch (0.4-mm) difference between edges of adjacent units, where edge line continues across joint.

3.4 INSTALLATION OF COUNTERTOPS

- A. General: Install countertops by adhering to supports with water-cleanable epoxy adhesive.
- B. Do not cut composite stone in field, unless otherwise indicated. If composite stone countertops or splashes require additional fabrication not specified to be performed at Project site, return to fabrication shop for adjustment.
- C. Set composite stone to comply with requirements indicated on Drawings and Shop Drawings. Shim and adjust composite stone to locations indicated, with uniform joints of widths indicated and with edges and faces aligned according to established relationships and indicated tolerances. Install anchors and other attachments indicated or necessary to secure composite stone countertops in place.
- D. Bond joints with composite stone adhesive and draw tight as countertops are set. Mask areas of countertops adjacent to joints to prevent adhesive smears.
- E. Apply sealant to joints and gaps specified for filling with sealant; comply with Division 07 Section "Joint Sealants." Remove temporary shims before applying sealant.

3.5 ADJUSTING AND CLEANING

- A. In-Progress Cleaning: Clean countertops as work progresses. Remove adhesive and sealant smears immediately.
- B. Remove and replace composite stone countertops of the following description:
 - 1. Broken, chipped, stained, or otherwise damaged composite stone.
 - 2. Defective countertops.
 - 3. Defective joints, including misaligned joints.
 - 4. Interior composite stone countertops and joints not matching approved Samples and mockups.
 - 5. Interior composite stone countertops not complying with other requirements indicated.
- C. Replace in a manner that results in composite stone countertops matching approved Samples and mockups, complying with other requirements, and showing no evidence of replacement.
- D. Clean composite stone countertops not less than six days after completion of sealant installation, using clean water and soft rags. Do not use wire brushes, acid-type cleaning agents, cleaning compounds with caustic or harsh fillers, or other materials or methods that could damage composite stone.

END OF SECTION 123661

SECTION 124813 - ENTRANCE FLOOR MATS AND FRAMES

PART 1 - GENERAL

1.1 SUMMARY

- A. This Section includes the following:
 - 1. Surface-mounted berber carpet mats

1.2 SUBMITTALS

- A. Product data for each type of floor mat and frame specified, including manufacturer's specifications and installation instructions, details of construction relative to materials, dimensions of individual components, profiles, and finishes..
- B. Shop drawings showing layout and types of floor mat, full-scale sections of typical installations, details of patterns or designs, anchors, and accessories.
- C. Samples for Architect's initial selection of manufacturer's full line of available colors for berber carpet mats..
- D. Maintenance data in the form of manufacturer's printed instructions for cleaning and maintaining floor mats.

1.3 QUALITY ASSURANCE

- A. Single-Source Responsibility: Obtain each type of floor mats from one source of a single manufacturer.

1.4 PROJECT CONDITIONS

- A. Field Measurements: Check actual framed openings for mats by accurate field measurements before fabrication; show recorded measurements on final shop drawings. Coordinate fabrication schedule with construction progress to avoid a delay of the Work.

PART 2 - PRODUCTS

2.1 MANUFACTURERS

- A. Available Manufacturers: Subject to compliance with requirements, manufacturers offering products that may be incorporated in the Work include, but are not limited to, the following:
 - 1. Construction Specialties, Inc.
 - 2. Mats Inc.

3. Reese Enterprises, Inc.
4. Pawling Corp.

2.2 MATS

- A. Carpet-Tile Type Mats: Non-woven needle punched solution dyed polypropylene carpet bonded to non-skid rubber backing to form ½" thick matting.
 1. Pile Weight: 52 oz/sq yd
 2. Product Weight: 93 oz./sq. yd.
 3. Flammability: Passes DOC FF-1-70
 4. Pattern: Nubby Hobnail
 5. Colors, Textures, and Patterns: As selected by Architect.
 6. Mat Width: 6'-6" or 13'-2" as required to cover substrate width in one piece without seams
 7. Basis of Design Product: "EM-20 Berber Carpet Matting" by Pawling Corp., or equal.
- B. Mat Frame: Beveled surface aluminum frame 2" long, finish as selected by Architect.
 1. Basis of Design Product: BSF-225 by Pawling.

2.3 FABRICATION

- A. Shop-fabricate units of floor mat work to greatest extent possible in sizes as indicated. Where not indicated otherwise, provide single unit for each mat installation, but do not exceed manufacturer's maximum size recommendation for units intended for removal and cleaning. Where joints in mats are necessary, space symmetrically and away from normal traffic lanes and note locations on shop drawings. Where possible, verify sizes by field measurement before shop fabrication.
- B. Fabricate frame members in single lengths or, where frame dimensions exceed maximum available lengths, provide minimum number of pieces possible, with hairline joints equally spaced and pieces spliced together by means of straight connecting pins.

PART 3 - EXECUTION

3.1 INSTALLATION

- A. Loose lay mats to comply with manufacturer's instructions at locations indicated.

3.2 PROTECTION

- A. Defer installation of floor mats until time of Substantial Completion for Project.

END OF SECTION 124813

The following additions, substitutions, or clarifications are extracted from the (5) Bid Addenda issued with this project during bidding. This insert is intended to summarize addendum information relevant to this specification section. See Bid Addenda issued by the City of Yonkers for complete contract document changes.

Bid Addendum No. 4:

RFI: Telescoping Seating: Note 1.8 of the spec notes Maintenance Service. Please advise if any of this cost is part of Contract No. 1 – General Construction Work.

YJSCB RESPONSE: Maintenance Service is not required to be included as part of the GC Contract.

RFI: Telescoping Seating: Note 2.4.B.5 indicates first riser 16-7/8", however this is not standard. Please confirm 16-7/8" first riser is required.

YJSCB RESPONSE: This is the dimension to the top of the first seat.

RFI: Telescoping Seating: Note 2.5.A.2 indicates 12" wood bench depth, which is not standard. Please confirm 12" bench depth is required.

YJSCB RESPONSE: The wood bench depth shall be standard 10".

RFI: Telescoping Seating: Note 2.5.H.1 indicates aisle closures at aisles when system is stored, however the bleacher is only 3-Tiers. Please confirm aisle closures are required.

YJSCB RESPONSE: Confirmed, provide aisle closures.

RFI: Telescoping Seating: Note 2.5.H.3 indicates end panels, however the bleacher is only 3-Tiers. Please confirm end panels are required.

YJSCB RESPONSE: Confirmed, provide end panels.

RFI: Telescoping Seating: Note 2.5.I.1 indicates end closure curtains, however the bleacher is only 3-Tiers. Please confirm end closure curtains are required

YJSCB RESPONSE: End closure curtains are not required.

RFI: Telescoping Seating: Note 2.5.I.2 indicates top row ball deflector curtain, however the bleacher is only 3-Tiers. Please confirm top row ball deflector curtains are required.

YJSCB RESPONSE: Top row ball deflector curtain is not required.

RFI: Telescoping Seating: Note 1.6.A.3 of the spec indicates a Lifetime warranty, however this is not typical for a knocked-down type lockers. Please advise.

YJSCB RESPONSE: Per manufacturer, a lifetime warranty does apply for this product.

SECTION 126600 - TELESCOPING STANDS

PART 1 - GENERAL

1.1 SUMMARY

- A. This Section includes the following:
 - 1. Wall-attached telescoping stands, manually operated.

1.2 ACTION SUBMITTALS

- A. Product Data: For each type of telescoping stand specified, including details of construction relative to materials, dimensions of individual components, profiles, and finishes.
 - 1. Include load capacities, assembly characteristics, and furnished accessories.
- B. Shop Drawings: For telescoping stands in both stacked and extended positions. Include plans, elevations, sections, and attachment details. Include load capacities. Show seating layout, aisle widths, row-lettering and seat-numbering scheme, and wheelchair accessibility provisions.
- C. Samples for initial selection in the form of manufacturer's color charts consisting of actual units or sections of units showing the full range of colors, textures, and patterns available for each exposed material involving color selection.
- D. Samples for verification of the following items, in the size indicated below. Prepare Samples from the same material to be used for the Work. Where finishes involve normal color and texture variations, include Sample sets showing the full range of variations expected.
 - 1. Decking: 6-inch-square Samples of finished material.

1.3 INFORMATIONAL SUBMITTALS

- A. Qualification Data: For installer and maintenance service technicians.
- B. Welding certificates.
- C. Product Test Reports: For load tests to all design loads, observed by a qualified independent testing laboratory, and certified by a registered professional structural engineer verifying the integrity of the manufacturer's design.
- D. Warranty: Manufacturers standard warranty documents.

- E. Field quality-control reports.

1.4 CLOSEOUT SUBMITTALS

- A. Operation and maintenance data for telescoping stands, including detailed instructions for operation and annual inspection requirements of authorities having jurisdiction, to include in the operation and maintenance manual specified in Division 01.

1.5 QUALITY ASSURANCE

- A. Installer Qualifications: Engage an experienced Installer to perform work of this Section who has specialized in installing types of telescoping stands similar to those required for this Project and who is acceptable to, or certified by, manufacturer of telescoping stands.
- B. Professional Engineer Qualifications: Engineer telescoping stands by a professional engineer who is legally authorized to practice in the State of New York and who is experienced in providing engineering services of the kind indicated. Engineering services are defined as those performed for installations of telescoping stands that are similar to that indicated for this Project in material, design, and extent.
- C. Maintenance Service Technicians Qualifications: Factory certified technicians directly employed by the Installer. All full-time service personnel shall be factory authorized and trained.
- D. Fire-Test Response Characteristics of Plastic Materials: Provide plastic materials identical to those tested for fire-exposure behavior per test method indicated below by a testing and inspecting agency acceptable to authorities having jurisdiction. Identify materials with appropriate markings of applicable testing and inspecting agency.
 - 1. Self-Ignition Temperature: 600 deg F (315 deg C) or greater for plastic material when tested per ASTM D 1929.
 - 2. Relative-Burning Characteristics: Tested per ASTM D 635. Burning extent of 1 inch (25 mm) or less.
- E. Welding Standards: Comply with applicable provisions of AWS D1.1 "Structural Welding Code--Steel" and AWS D1.3 "Structural Welding Code--Sheet Steel."
 - 1. Engage certified welders that have satisfactorily passed AWS qualification tests for welding processes involved and, if pertinent, have undergone recertification.

1.6 PROJECT CONDITIONS

- A. Field Measurements: Check actual dimensions of construction affecting telescoping stands by accurate field measurements before fabrication and show recorded measurements on Shop Drawings. Coordinate fabrication schedule with construction progress to avoid delaying the Work.

- B. Finished Spaces: Do not deliver or install telescoping stands until finishes in spaces to receive them are complete, including suspended ceilings, floors, and painting.

1.7 WARRANTY

- A. Manufacturer's Warranty: Provide a warranty covering the repair or replacement of the defective product; or defective component thereof, with a comparable product; or component thereof, or a refund of the purchase price prorated over the warranty period. Include labor, materials, and freight for replacement or repairs.

1. Structural Component parts of Understructure Warranty Period: 10 years from Substantial Completion.
2. Decking systems, seating collections, electrical, portable and integral dolly systems, end closure curtains, surface material finishes Warranty Period: 5 years from Substantial Completion.

1.8 MAINTENANCE SERVICE

- A. Maintenance Service: Provide maintenance service by qualified full time Maintenance Service Technicians directly employed by the telescoping stand Installer for period of five (5) years following date of Substantial Completion. Include monthly preventive maintenance, performed during normal working hours. Include repair/replacement of worn or defective parts or components and lubrication, cleaning and adjusting as required for proper telescoping stand operation in conformance with ICC 300 and specified requirements. A four to eight-hour maximum on-site repair response is required during normal working hours, 8 a.m. to 5 p.m. weekdays (excluding holidays). Exclude only repair/replacement due to misuse, abuse, accidents or neglect caused by persons other than Installer's personnel.

1. Perform yearly inspection and testing of telescoping stand per ICC 300 requirements, with the last inspection and testing performed in the final week of the maintenance service period.

- B. Continuing Maintenance Service: Provide a continuing maintenance proposal from Installer to Owner, in the form of a standard yearly (or other period) maintenance agreement, starting on date construction contract maintenance requirement are concluded. State services, obligations, conditions, and terms for agreement period and for future renewal options.

PART 2 - PRODUCTS

2.1 PERFORMANCE REQUIREMENTS

- A. Structural Performance Characteristics: Engineer, fabricate, and install telescoping stands to withstand the following structural loads without exceeding the allowable design working stresses of the materials involved, including anchors and connections. Apply

each load to produce the maximum stress in each respective component of each telescoping stand unit according to ICC 300.

B. Design Loads.

1. Design folding and telescopic seating to support, in addition to its own weight and the weight of added accessories, a uniformly distributed live load of not less than 100 lb/ft² (488 kg/m²) of gross horizontal projection.
2. Design seat boards and footrests for a live load of not less than 120 lb/linear ft (179 kg/linear m).
3. Design folding and telescopic seating to support a sway force applied to seats 24 lb/linear ft (36 kg/linear m) parallel to the seats and 10 lb/linear ft (15 kg/linear m) perpendicular to the seats. Sway forces shall not be required to be applied simultaneously.
4. Design handrails to support the following loads applied separately:
 - a. A concentrated load of 200 lb (91 kg) applied at any point and in any direction,
 - b. A uniform load of 50 lb/ft (74 kg/m) applied in any direction.
5. Design guards to support the following loads applied separately:
 - a. A concentrated load of 200 lb (91 kg) applied at any point and in any direction along the top railing member
 - b. A uniform load of 50 lb/ft (74 kg/m) applied at any direction at top rail.
 - c. A uniform load of 50 lbs (0.22 kN) applied on an area equal to 1 sq. ft. (0.09 sq. m) applied on all guardrail infill panels.

C. Accessibility Standard: Comply with applicable provisions in the DOJ's 2010 ADA Standards for Accessible Design.

2.2 MANUFACTURERS

A. Manufacturers: Provide Basis of Design products by Hussey Seating Company USA or equal products by one of the following:

1. Interkal Inc.
2. Irwin Seating Company; Folding Bleacher Company Subsidiary.

2.3 MATERIALS

- A. Plywood: Softwood plywood panels, 5/8-inch (15.9-mm) nominal thickness, 5-ply construction with grade designation American Plywood Association (APA) A-C Exterior, with solid crossbands, Group 1 veneer species for plies, and exterior glue, APA grade trademarked, complying with DOC PS 1 requirements, unless otherwise noted.
- B. Polyethylene Plastic-Faced Plywood Deck: Polyethylene plastic-overlay panel that complies with requirements of DOC PS 1 and is fabricated with a skid-resistant, textured, high-density polyethylene plastic moisture barrier in manufacturer's standard color bonded to a plywood substrate with exterior glue.

- C. Structural Steel Shapes, Plates, and Bars: ASTM A 36 (ASTM A 36M).
- D. Commercial-Quality Uncoated Steel Sheet: ASTM A 366 (ASTM A 366M) cold-rolled steel sheet, or ASTM A 569 (ASTM A 569M) hot-rolled steel sheet, stretcher leveled.
- E. Structural-Quality Uncoated Steel Sheet: ASTM A 570 (ASTM A 570M) hot-rolled steel sheet, or ASTM A 611 cold-rolled steel sheet, stretcher leveled.
- F. High-Strength Uncoated Steel Sheet: ASTM A 607 hot- or cold-rolled steel sheet, stretcher leveled.
- G. Galvanized Steel Sheet: ASTM A 653, G60 (ASTM A 653M, Z180) coating designation, phosphatized, stretcher leveled.
- H. Steel Tubing: ASTM A 500, cold formed; or ASTM A 501, hot formed.
- I. Polyethylene Plastic: High-density polyethylene; injection molded, color-pigmented, textured, impact-resistant, and dimensionally stable.

2.4 TELESCOPING STANDS

- A. General: Provide manufacturer's standard telescoping stands fabricated to comply with requirements indicated. Smoothly round corners, edges, and exposed fasteners to eliminate snagging and pinching hazards. Form exposed sheet metal with flat, flush surfaces, true to line and level, and without cracking and grain separation. Perform welding by operators and processes complying with AWS requirements.
- B. Wall-Attached Telescoping Stands : Forward-folding system, in which the bleachers open in the forward direction by moving the front row away from the stack to the fully extended position and the rear of bleacher understructure permanently attaches to wall construction
 - 1. Bank Lengths: 32'-4-1/2".
 - 2. Number of Tiers: 3.
 - 3. Aisle Width: 4'-6".
 - 4. Row Spacing: 22 inches for first row, 26 inches for second row.
 - 5. Row Rise: First riser 16-7/8", then two risers at 9-5/8" each.
 - 6. Open Dimension: 6'-0-5/16".
 - 7. Closed Dimension: 3'-5".
 - 8. Overall Unit Height: 3'-0-1/8".
 - 9. Net Capacity: 48 per each 32' bank.
 - 10. Operation: Manual. User operates system by manually pulling/pushing each section with operating handles.
 - 11. Basis of Design Product: Provide MAXAM by Hussey Seating Company, U.S.A or equal products of one of the following:
 - a. Interkal.
 - b. Irwin Seating Company.

2.5 COMPONENTS

- A. Classic Wood Benches: Seats and front risers.
1. Material: Lumber with clear finish.
 2. Bench Depth: 12 inches (305 mm).
 3. Top Seat Flush Filler: Flush filler board mounted between top seat and rear wall.
- B. ADA Seating: Provide first row modular recoverable seating units that can be closed to accommodate persons requiring ADA spaces (or any other temporary space needs) or opened for standard usage for team seating or facility specific requirements.
1. Provide a black full-surround steel skirting with no more than $\frac{3}{4}$ " floor clearance and a black injection molded end cap for the nose beam for safety and improved aesthetics.
 2. Provide a mechanical positive lock when the seating system is in both the open and closed position. Handle shall unlock each modular recoverable seating unit for operation.
 3. Modular units shall be located and sized as indicated on the Drawings. Provide three ADA seating positions per bank of bleachers, a total of six for project.
 4. Provide with signage to mark the location of each recoverable seating module to assist with seating identification.
 5. Basis of Design Product: Flex-Row by Hussey, or equal.
- C. Decking: 5/8 inch thick BC grade tongue and groove Douglas Fir plywood with 0.03 inch thick polyethylene overlay bonded to substrate.
1. Color: As selected by Architect.
 2. Basis of Design Product: Polydeck by Hussey, or equal.
- D. Risers: Fabricate risers from steel sheet with painted or galvanized finish, as standard with manufacturer.
1. Provide wall pads on the bleacher fronts when closed, in solid color selected by Architect. Coordinate with Section 114900 for wall pads.
- E. Safety Railings:
1. End Rails: Provide steel self-storing starting no higher than tier 2 high (or 42") above seat, end rail with tubular supports and intermediate members designed with 4 inch sphere passage requirements.
 2. Center Aisle Rails: Provide auto-rotating type, single pedestal mount handrails 34 inches high with terminating mid rail. Permanently attached handrail shall rotate in a permanently mounted socket for rail storage. Rail shall automatically rotate, lock in the use position, unlock and rotate back to the stowed position as the gym seats open and close. Ends of the handrail shall return to the post, and not extend away from it.
 3. Material and Finish: As selected by Architect.

4. Color: Black, semi-gloss finish.
- F. Understructure: Fabricate understructure from structural steel members of size, spacing, and form required to support design loads. Provide the following components:
1. Tubular nose beam and rear riser beams through-bolted to deck stabilizers and frame cantilevers to create the deck structure.
 2. Frames: Welded assemblies with continuous positive interglide system and interlocks at lower frame, slant columns, cantilever subassembly and lower track wheels consisting of nonmarring, soft, rubber wheels of size, number, and design required to support stands and to achieve smooth operation without damage to flooring surface, but not less than 5 wheels per frame.
 3. Sway bracing
 4. Deck stabilizer.
 5. Lock system consisting of low profile Posi-Lock LX to lock each row in open position and allow unlocking automatically.
 6. Finishes:
 - a. Understructure: Rust-inhibiting black finish.
 - b. Hardware: Zinc-plated, Rust inhibiting black finish.
 - c. Posi-Locks and Other Surfaces: Powder coated black, rust inhibiting black finish.
- G. Steps: Provide front aisle step and intermediate aisle steps as follows:
1. Front aisle step shall be permanently hinged to the front row, and shall have two 3" diameter x $\frac{3}{4}$ " wide non-marking front wheels for operating into the open and closed positions, and all edges coined, hemmed or radiused with front edge protective rubber bumpers. Provide abrasive-backed non-slip tread identifier on leading edge of nosing. For aisle widths greater than 6'-0", provide two side by side hinged steps.
 - a. Basis of Design Product: Sure-Step by Hussey, or equal.
 2. Intermediate aisle steps shall be fully enclosed, at each vertical aisle, with full radius end caps on all four edges and adhesive-backed abrasive non-slip tread surface.
- H. Closure Panels: Provide in materials and colors to match decking, and as follows:
1. Aisle closures at foot level that produce flush vertical face at aisles when system is stored.
 2. Fixed front closure panels on first row to prevent players and objects from sliding beneath the first row, extending to 1-1/2 inches of floor.
 3. End panels covering exposed ends of stands in the stored position.
 4. Rear fillers including supports for closing openings between top row and rear wall of adjoining construction.
- I. Accessories: Provide the following accessories of manufacturer's standard design and construction at locations indicated or required to comply with referenced code standard:

1. Safety end closure curtains permanently attached to structure to prevent access to understructure when bleacher is fully extended.
2. Top row ball deflector curtain, secured with velcro to prevent lodging of basketballs and foreign objects.

2.6 STEEL FINISHES

- A. Surface Preparation: Solvent-clean surfaces to comply with SSPC-SP 1 to remove dirt, oil, grease, and other contaminants that could impair paint bond. Remove mill scale and rust, if present, from uncoated steel complying with SSPC-SP 5 (White Metal Blast Cleaning) or SSPC-SP 8 (Pickling).
- B. Rust-Inhibitive Finish: Immediately after cleaning and pretreating, apply manufacturer's standard rust-inhibitive finish to exposed and concealed metal surfaces including understructure, except where other types of finishes are indicated.
 1. Finish: One of the following, as is standard with manufacturer
 - a. Manufacturer's standard water-based acrylic finish applied using a dipping process.
 - b. Manufacturer's standard alkyd enamel finish consisting of prime coat and topcoat.
 - c. Manufacturer's standard epoxy-resin-based finish consisting of prime coat and topcoat.

PART 3 - EXECUTION

3.1 EXAMINATION

- A. Examine areas where telescoping stands are to be installed, with Installer present, for compliance with requirements for installation tolerances and other conditions affecting performance of telescoping stands. Do not proceed with installation until unsatisfactory conditions have been corrected.

3.2 INSTALLATION

- A. Install telescoping stands according to ICC 300 and in compliance with manufacturer's instructions and Shop Drawings. Provide accessories indicated and anchors, fasteners, inserts, and other items required for installing and attaching units to adjoining construction.

3.3 FIELD QUALITY CONTROL

- A. Testing Agency: Engage a qualified testing agency to perform tests and inspections.
- B. Perform the following tests and inspections:

1. ICC 300 Inspection: Inspect installed telescoping stands to verify that construction, installation, and operation are according to ICC 300 requirements.
2. Test and adjust controls and safeties. Replace damaged and malfunctioning controls and equipment.

C. Telescoping stands will be considered defective if they do not pass tests and inspections.

D. Prepare and submit test and inspection reports.

3.4 ADJUSTING AND CLEANING

A. On completion of installation, including work of other trades, lubricate, test, and adjust each telescoping stand unit to operate easily and to comply with manufacturer's specifications.

B. Clean installed telescoping stands on exposed and semiexposed surfaces. Touch up shop-applied finishes to restore damaged or soiled areas.

3.5 DEMONSTRATION

A. Engage a factory-authorized service representative to demonstrate and train Owner's maintenance personnel as specified below.

1. Test and adjust controls and safeties. Replace damaged and malfunctioning controls and equipment.
2. Train Owner's maintenance personnel on procedures and schedules related to operation, troubleshooting, servicing, inspection, and maintenance.
3. Review data in the operation and maintenance manuals.
4. Schedule training with Owner, through Architect, with at least 7 days' advance notice.

3.6 PROTECTION

A. Provide final protection and maintain conditions, in a manner acceptable to manufacturer and Installer, that ensure telescoping stands are without damage or deterioration at the time of Substantial Completion.

END OF SECTION 126600

SECTION 142100 - ELECTRIC TRACTION ELEVATORS

PART 1 - GENERAL

1.1 SUMMARY

- A. This Section includes electric traction passenger elevators.
- B. Related Sections include the following:
 - 1. Division 03 Section for setting sleeves, inserts, and anchoring devices in concrete.
 - 2. Division 04 Section for setting sleeves, inserts, and anchoring devices in masonry.
 - 3. Division 05 Sections for the following:
 - a. Attachment plates, angle brackets, and other preparation of structural steel for fastening guide-rail brackets.
 - b. Machine beams.
 - c. Structural-steel shapes for subsills and entrance frames that are part of steel frame.
 - d. Pit ladders.
 - 4. Division 09 Sections for finish flooring in elevator cars.
 - 5. Division 26 Section for smoke detectors in elevator lobbies to initiate emergency recall operation and heat detectors in shafts and machine rooms to disconnect power from elevator equipment before sprinkler activation and for connection to elevator controllers.
 - 6. Division 26 Section for telephone service to elevators.
 - 7. Division 26 Sections for electrical service for elevators to and including fused disconnect switches at machine room door and standby power source, transfer switch, and connection from auxiliary contacts in transfer switch to controller.

1.2 DEFINITIONS

- A. Defective Elevator Work: Operation or control system failures; performances below specified ratings; excessive wear; unusual deterioration or aging of materials or finishes; unsafe conditions; the need for excessive maintenance; abnormal noise or vibration; and similar unusual, unexpected, and unsatisfactory conditions.

1.3 SUBMITTALS

- A. Product Data: Include capacities, sizes, performances, operations, safety features, finishes, and similar information. Include product data for the following:
 - 1. Car enclosures and hoistway entrances.
 - 2. Operation, control, and signal systems
- B. Shop Drawings: Show plans, elevations, sections, and large-scale details indicating service at each landing, machine room layout, coordination with building structure,

relationships with other construction, and locations of equipment and signals. . Include large-scale layout of car control station and standby power operation control panel. Indicate variations from specified requirements, maximum dynamic and static loads imposed on building structure at points of support, and maximum and average power demands.

- C. Samples: For exposed finishes of cars, hoistway doors and frames, and signal equipment; 3-inch- (75-mm-) square samples of sheet materials; and 4-inch (100-mm) lengths of running trim members.
- D. Manufacturer Certificates: Signed by elevator manufacturer certifying that hoistway, pit, and machine room layout and dimensions, as shown on Drawings, and electrical service, including emergency generator, as shown and specified, are adequate for elevator system being provided.
- E. Maintenance Manuals: Include operation and maintenance instructions, parts listing with sources indicated, recommended parts inventory listing, emergency instructions, and similar information. Include diagnostic and repair information available to manufacturer's and Installer's maintenance personnel. Submit for Owner's information at Project closeout.
- F. Inspection and Acceptance Certificates and Operating Permits: As required by authorities having jurisdiction for normal, unrestricted elevator use.
- G. Qualification Data: For Installer
- H. Warranty: Special warranty specified in this Section.

1.4 QUALITY ASSURANCE

- A. Installer Qualifications: Elevator manufacturer or an experienced installer approved by elevator manufacturer who has completed elevator installations similar in material, design, and extent to that indicated for this Project and with a record of successful in-service performance.
- B. Regulatory Requirements: In addition to local governing regulations, comply with applicable provisions in ASME A17.1, "Safety Code for Elevators and Escalators" and Building Code of New York State.
- C. Accessibility Requirements: In addition to local governing regulations, comply with ANSI A117.1 - 2017.
- D. NFPA: Comply with applicable NFPA codes, and specifically with sections relating to electrical work and elevators.
- E. Fire-Rated Door Assemblies: Door and frame assemblies complying with NFPA 80 that are listed and labeled by a testing and inspecting agency acceptable to authorities having jurisdiction, for fire-protection ratings indicated, based on testing at as close to neutral pressure as possible according to NFPA 252.

- F. Design Criteria: The drawings and specifications indicate the cab clear inside dimensions, motor horsepower and hoistway dimensional requirements and other requirements of the electric traction elevator, and are based on the specific types and models indicated. Electric traction elevators by other manufacturers may be considered, provided deviations in dimensions are minor, and do not change the hoistway dimensions. Motor horsepower must be less than or equal to that specified or the proposer shall pay all costs associated with increasing electrical service to elevator as necessary. The burden of proof of equality is on the proposer.

1.5 COORDINATION

- A. Coordinate installation of sleeves, block outs, elevator equipment with integral anchors, and other items that are embedded in concrete or masonry for elevator equipment. Furnish templates, sleeves, elevator equipment with integral anchors, and installation instructions and deliver to Project site in time for installation.
- B. Coordinate locations and dimensions of other work relating to electric traction elevators including pit ladders, sumps, and floor drains in pits; entrance subsills; and electrical service, electrical outlets, lights, and switches in pits and machine rooms.

1.6 WARRANTY

- A. Special Manufacturer's Warranty: Written warranty, signed by manufacturer agreeing to repair, restore, or replace defective elevator work within specified warranty period.
 - 1. Warranty Period: 12 months from date of Acceptance.

1.7 MAINTENANCE SERVICE

- A. Initial Maintenance Service: Beginning at Acceptance, provide 12 months' full maintenance service by skilled employees of the elevator Installer. Include monthly preventive maintenance, repair or replacement of worn or defective components, lubrication, cleaning, and adjusting as required for proper elevator operation at rated speed and capacity. Provide parts and supplies as used in the manufacture and installation of original equipment.
 - 1. Perform maintenance, during normal working hours.
 - 2. Provide emergency 24-hour callback service.
 - a. Response Time: Two hours or less.
- B. Continuing Maintenance Proposal: Provide a continuing maintenance proposal from Installer to Owner in the form of a standard yearly (or other period) maintenance agreement, starting on date initial maintenance service is concluded. State services, obligations, conditions, and terms for agreement period and for future renewal options.

PART 2 - PRODUCTS

2.1 MANUFACTURERS

- A. Manufacturers: Provide specified products of Otis or equivalent elevator manufactured by KONE or ThyssenKrupp.

2.2 MATERIALS AND COMPONENTS

- A. General: Provide manufacturer's standard elevator systems. Where components are not otherwise indicated, provide standard components, published by manufacturer as included in standard preengineered elevator systems and as required for a complete system.
 - 1. Provide machine-room-less type elevator.
- B. Passenger Elevator Machines: Provide variable-voltage, variable-frequency ac-type hoisting machines. Provide solid-state power converters.
 - 1. Provide energy-efficient machine with permanent magnet synchronous motor, dual solenoid service and emergency brakes, mounted to the car guide rail at the top of the hoistway.
 - 2. Provide regenerative drive system.
- C. Coated Steel Belts: Polyurethane coated belts with high-tensile-grade, zinc-plated steel cords and a flat profile on the running surface and the backside of the belt. All driving sheaves and deflector sheaves should have a crowned profile to ensure center tracking of the belts. A continuous 24/7 monitoring system using resistance based technology has to be installed to continuously monitor the integrity of the coated steel belts and provide advanced notice of belt wear
- D. Inserts: Furnish required concrete and masonry inserts and similar anchorage devices for installing guide rails, machinery, and other components of elevator work where installation of devices is specified in another Specification Section.
- E. Guide Rails and Attachments: Guide rails shall be Tee-section steel rails with brackets and fasteners. Side counterweight arrangements shall have a dual-purpose bracket that combines both counterweight guide rails, and one of the car guide rails to building fastening
- F. Car Frame and Platform: Welded steel units.
- G. Finish Materials: Provide the following materials and finishes for exposed parts of elevator car enclosures, car doors, hoistway entrance doors and frames, and signal equipment as indicated:
 - 1. Satin Stainless Steel: ASTM A 666, Type 304, with No. 4, directional satin finish.
 - 2. Enameled-Steel Sheet: Cold-rolled steel sheet complying with ASTM A 366/A 366M, matte finish, stretcher-leveled standard of flatness. Provide with factory-applied enamel finish; colors as selected by Architect.

3. Prime-Painted Steel Sheet: Cold-rolled steel sheet, ASTM A 366/A 366M, or hot-rolled steel sheet, ASTM A 569/A 569M, with factory-applied rust-inhibitive primer.
4. Plastic Laminate Wall Panels: High-pressure type complying with NEMA LD 3, Type GP-50; color, texture, and pattern as scheduled

2.3 OPERATION SYSTEMS

- A. Passenger Elevators: Provide manufacturer's standard microprocessor operation system for each elevator or group of elevators as required to provide type of operation system indicated.
 1. Single Elevator: Provide "selective collective automatic operation" as defined in ASME A17.1.
- B. Auxiliary Operations: In addition to primary operation system features, provide the following operational features for elevators where indicated
 1. Loaded-Car Bypass: When car load exceeds a predetermined weight, car will respond only to car calls, not to hall calls. Predetermined weight can be adjusted.
 2. Automatic Dispatching of Loaded Car: When car load exceeds a predetermined weight, doors will begin closing.
 3. Nuisance Call Cancel: When car calls exceed a preset number while the car load is less than a predetermined weight, all car calls are canceled. Preset number of calls and predetermined weight can be adjusted.
 4. Automatic Self-Leveling: Provide each elevator car with a self-leveling feature to automatically bring the car to the floor landings and correct for overtravel or undertravel. Self-leveling shall, within its zone, be automatic and independent of the operating device. Maintain the car approximately level with the landing irrespective of its load
 5. Independent Service: Keyswitch in car control station removes car from group operation and allows it to respond only to car calls. Key cannot be removed from keyswitch when car is in independent service. When in independent service, doors close only in response to the door close button.
 6. Automatic emergency recall and fire fighter's emergency service (Phase I fire service and Phase II car fire service in accordance with ASME A17.1);
 - a. Community Building: Return to ground floor - Gym Floor (designated floor), with alternate floor the Basement.
 - b. School Building: Return to First Floor (designated floor), with alternate floor the Second Floor.
 7. Controls for emergency operation shall be located in each car.
 8. Access at bottom landing with zoning.
 9. Access at top landing with zoning.

2.4 SIGNAL EQUIPMENT

- A. General: Provide signal equipment for each elevator or group of elevators with hall-call and car-call buttons that light when activated and remain lit until call has been fulfilled. Fabricate lighted elements of acrylic or other permanent, non-yellowing translucent plastic.
- B. Car Control Stations: Provide manufacturer's standard semirecessed or fully recessed car control stations. Mount in return panel adjacent to car door, if not otherwise indicated.
 - 1. Include call buttons for each landing served and other buttons, switches, and controls required for specified car operation.
 - 2. Mark buttons and switches with manufacturer's standard identification for required use or function that complies with ASME A17.1.
 - 3. Mount controls at heights complying with ANSI A117.1- 2017.
- C. Emergency Communication System: Provide system that complies with ASME A17.1 and ANSI A117.1-2017. On activation, system dials preprogrammed number of monitoring station and identifies elevator location to monitoring station. System provides two-way voice communication without using a handset and provides visible signals that indicate when system has been activated and when monitoring station has responded. System is contained in flush-mounted cabinet, with identification, instructions for use, and battery backup power supply.
- D. Car Position Indicator: For passenger elevator cars, provide illuminated-signal type, digital-display type, or segmented type, located above car door or above car control station. Also provide audible signal to indicate to passengers that car is either stopping at or passing each of the floors served.
 - 1. Include travel direction arrows if not provided in car control station.
- E. Key-Operated Hall Push-Button Stations: Provide one hall push-button station with keyed operation at each landing for each elevator or group of elevators, but not less than one station for each four elevators in a group. For each group of passenger elevators, locate between two elevators at center of group or at location most convenient for approaching passengers.
 - 1. Provide units with flat faceplate for mounting with body of unit recessed in wall.
 - 2. Provide units with direction-indicating buttons; two buttons at intermediate landings; one button at terminal landings.
 - 3. Firefighters Phase I key switch shall be located at First Floor for School Building and Gym Floor for Community Building.
- F. Combination Hall Lanterns/Hall Position Indicators: Provide illuminated-signal type or digital-display type, located above each hoistway entrance. Provide units with illuminated arrows, but provide single arrow at terminal landings.
 - 1. Provide units with flat faceplate for mounting with body of unit recessed in wall and with illuminated elements projecting from faceplate for ease of angular viewing.
 - 2. With each lantern, provide audible signals indicating car arrival and direction of travel, including floor passing signal.

- G. Corridor Call Station Pictograph Signs: Provide signs matching hall push-button stations with text and graphics according to ASME A17.1, Figure 2.27.9.
- H. Fireman's Warning Signal (Third Signal): Provide illuminated fireman's hat which shall light in the event a fire is detected in the elevator machine room or hoistway per NFPA 72-6.15.3.9 and ASME A17.1-2.27.3.2.6.
- I. Controllers: Provide contact points in the controllers for fire alarm system interface.
- J. Standby Power Elevator Selector Switches: Provide switches, as required by ASME A17.1, where indicated. Adjacent to switches, provide illuminated signal that indicates when normal power supply has failed. For each elevator, provide illuminated signals that indicate when they are operational and when they are at the designated emergency return level with doors open.

2.5 DOOR REOPENING DEVICES

- A. Infrared Array: Provide door reopening devices with a uniform array of 36 or more microprocessor-controlled, infrared light beams projecting across car entrance. Interruption of one or more of the light beams shall cause doors to stop and reopen.
 - 1. Nudging Feature: After car doors are prevented from closing for a predetermined adjustable time, through activating door reopening device, a loud buzzer shall sound and doors shall begin to close at reduced kinetic energy.

2.6 ELEVATOR MONITORING SYSTEM

- A. Remote Elevator Monitoring: Provide microprocessor controlled system that allows remote monitoring of elevators for maintenance needs and repair requests.

2.7 PASSENGER ELEVATOR CAR ENCLOSURES

- A. General: Provide manufacturer's standard steel-framed car enclosures with nonremovable wall panels as required for wall panel finish specified, suspended ceiling, trim, accessories, access doors, doors, power door operators, sills (thresholds), lighting, and ventilation.
 - 1. Stainless Steel: ASTM A 167, Type 302 or 304, with No. 4 satin finish.
 - 2. Sills: Extruded aluminum, with grooved surface, 1/4 inch thickness, mill finish.
 - 3. Wall Panels: Plastic laminate.
 - 4. Fabricate car door frame integrally with front wall of car in stainless steel.
 - 5. Fabricate car with recesses and cutouts for signal equipment.
 - 6. Car Doors: Satin finish stainless steel doors.
 - 7. Luminous Ceiling: Brushed stainless steel finish dropped steel ceiling with 6 round LED lights.
 - 8. Flooring: By others as specified in Division 09 Section "Resilient Flooring and Accessories".
 - 9. Handrails: Satin stainless steel, round 1-1/2", at sides and rear walls.

10. Wall Protection Pads: Provide hooks and removable protection pads for interior of cab to completely cover walls, in color selected by Architect.

- B. Emergency Light: Integrated emergency light in a module inclined 20 degrees from vertical, illuminating automatically upon loss of the building's normal power supply.
- C. Top of Car Access: Provide top of car access door complying with ASME/ANSI A17.1.
- D. Car Fan: Provide top of car ventilation fan, one-speed, with key-operated switch in car control station

2.8 PASSENGER HOISTWAY ENTRANCES

- A. General: Provide manufacturer's standard horizontal-sliding, door-and-frame hoistway entrances complete with track systems, hardware, sills, and accessories. Provide frame size and profile to coordinate with hoistway wall construction.
 - 1. Where gypsum board wall construction is indicated, provide self-supporting frames with reinforced head sections.
 - 2. Provide units bearing Underwriters' Laboratories "B" labels.
 - 3. Comply with elevator manufacturer's requirements for elevator wall interface with hoistway entrance assembly.
- B. Interlocks: Equip each hoistway entrance with an Underwriters' Laboratories "B" label approved type interlock tested as required by code. Design interlock to prevent operation of the car away from the landing until the doors are locked in the closed position as defined by code and prevent opening the doors at any landing from the corridor side unless the car is at rest at that landing or is in the leveling zone and stopping at that landing.
- C. Materials and Fabrication: Provide manufacturer's standards but not less than the following:
 - 1. Stainless-Steel Frames: Formed from stainless steel sheet, with satin finish.
 - 2. Stainless-Steel Doors: Flush, hollow-metal construction, fabricated from stainless steel with satin finish.
 - 3. Sills: Extruded aluminum, with grooved surface, 1/4 inch (6 mm) thickness, mill finish.
 - 4. Nonshrink, Nonmetallic Grout: Factory-packaged, nonstaining, noncorrosive, nongaseous grout complying with ASTM C 1107.

2.9 SIGNAGE

- A. Provide signage complying with Safety Code for Elevators and Escalators (ASME A17.1), ANSI A117.1 - 2017 and the Building Code of New York State.

2.10 PASSENGER ELEVATORS

- A. Elevator No. 1: School Building

1. Type: One front and rear opening gearless traction elevator
2. Basis of Design Product: Otis Gen 2, or equal.
3. Rated Load: 2100 lb.
4. Rated Speed: 200 fpm.
5. Operation System: Simplex operation, microprocessor control.
6. Power Characteristics: 208V, 3 phase, 60 Hz.
7. Number of Stops: 6
8. Auxiliary Operations:
 - a. Loaded-car bypass.
 - b. Automatic dispatching of loaded car.
 - c. Nuisance call cancel.
 - d. Access at top landing with zoning.
 - e. Access at bottom landing with zoning.
 - f. Earthquake Emergency Operation: Comply with requirements in ASME A17.1.
 - g. Elevator shall be tied into building emergency power system.
 - h. Automatic emergency recall and fire fighter's emergency service (Phase I fire service and Phase II car fire service in accordance with ASME A17.1); return to First Floor (designated floor), with alternate floor the Second Floor.
 - i. Options: Provide all optional features specified or as required for code compliance.
9. Car Enclosures: As follows:
 - a. Inside Width: 5'-8"
 - b. Inside Depth: 4'-3"
 - c. Inside Height: 8'-0"
 - d. Front Walls: Satin stainless steel with integral car door frames.
 - e. Car Fixtures: Satin stainless steel.
 - f. Car Walls: Plastic laminate by Wilsonart, in color and pattern as selected by Architect. .
 - g. Door Faces (Interior): Satin stainless steel.
 - h. Door Sills: Aluminum.
 - i. Ceiling: Satin finish dropped stainless steel ceiling with 3 panels and 6 round LED lights.
 - j. Handrails: Satin stainless steel, round 1-1/2" diameter, at sides and rear walls.
 - k. Floor: By others as specified in Division 09 Section "Resilient Flooring and Accessories."
 - l. Ventilation: Fan.
10. Hoistway Entrances: As follows:
 - a. Width: 3'-6"
 - b. Height: 7'-0"
 - c. Type: One speed center opening.
 - d. Frames: Stainless steel.
 - e. Doors: Stainless steel.
 - f. Sills: Aluminum.

11. Hall Fixtures: Satin stainless steel
12. Additional Requirements: As follows:
 - a. Provide inspection certificate in each car, mounted under acrylic cover with satin stainless-steel frame.
 - b. Provide protective blanket hooks on cab front and walls and one set of vinyl full-height protection pads in color selected by Architect.
 - c. Provide inspection switch and car top inspection station.

B. Elevator No. 2: Community Building

1. Type: One front opening gearless traction elevator
2. Basis of Design Product: Otis Hydrofit 2510, or equal.
3. Rated Load: 2500 lb.
4. Rated Speed: 100 fpm.
5. Operation System: Simplex operation, microprocessor control.
6. Power Characteristics: 208V, 3 phase, 60 Hz.
7. Number of Stops: 2
8. Auxiliary Operations:
 - a. Loaded-car bypass.
 - b. Automatic dispatching of loaded car.
 - c. Nuisance call cancel.
 - d. Access at top landing with zoning.
 - e. Access at bottom landing with zoning.
 - f. Earthquake Emergency Operation: Comply with requirements in ASME A17.1.
 - g. Elevator shall have emergency battery backup.
 - h. Automatic emergency recall and fire fighter's emergency service (Phase I fire service and Phase II car fire service in accordance with ASME A17.1); return to ground floor - Gym Floor (designated floor), with alternate floor the Basement.
 - i. Options: Provide all optional features specified or as required for code compliance.
9. Car Enclosures: As follows:
 - a. Inside Width: 5'-8"
 - b. Inside Depth: 4'-3"
 - c. Inside Height: 8'-0"
 - d. Front Walls: Satin stainless steel with integral car door frames.
 - e. Car Fixtures: Satin stainless steel.
 - f. Car Walls: Plastic laminate by wilsonart, in color and pattern as selected by Architect. .
 - g. Door Faces (Interior): Satin stainless steel.
 - h. Door Sills: Aluminum.
 - i. Ceiling: Satin finish dropped stainless steel ceiling with 3 panels and 6 round LED lights.
 - j. Handrails: Satin stainless steel, round 1-1/2" diameter, at sides and rear walls.
 - k. Floor: By others as specified in Division 09 Section "Resilient Flooring and Accessories."

- I. Ventilation: Fan.
- 10. Hoistway Entrances: As follows:
 - a. Width: 3'-6"
 - b. Height: 7'-0"
 - c. Type: One speed center opening.
 - d. Frames: Stainless steel.
 - e. Doors: Stainless steel.
 - f. Sills: Aluminum.
- 11. Hall Fixtures: Satin stainless steel
- 12. Additional Requirements: As follows:
 - a. Provide inspection certificate in each car, mounted under acrylic cover with satin stainless-steel frame.
 - b. Provide protective blanket hooks on cab front and walls and one set of vinyl full-height protection pads in color selected by Architect.
 - c. Provide inspection switch and car top inspection station.

PART 3 - EXECUTION

3.1 EXAMINATION

- A. Examine elevator areas, with Installer present, for compliance with requirements for installation tolerances and other conditions affecting performance. Examine hoistways, hoistway openings, pits, and machine rooms as constructed; verify critical dimensions; and examine supporting structure and other conditions under which elevator work is to be installed. Proceed with installation only after unsatisfactory conditions have been corrected.
 - 1. For the record, prepare a written report, endorsed by Installer, listing dimensional discrepancies and conditions detrimental to performance.

3.2 INSTALLATION

- A. Comply with manufacturer's written instructions.
 - 1. Install hoistway frames according to NFPA 80
- B. Welded Construction: Provide welded connections for installing elevator work where bolted connections are not required for subsequent removal or for normal operation, adjustment, inspection, maintenance, and replacement of worn parts. Comply with AWS standards for workmanship and for qualifications of welding operators.
- C. Sound Isolation: Mount rotating and vibrating equipment on vibration-isolating mounts designed to minimize transmission of vibrations to structure and thereby minimize structure-borne noise from elevator system.

- D. Lubricate operating parts of systems, including ropes, as recommended by manufacturers.
- E. Alignment: Coordinate installation of hoistway entrances with installation of elevator guide rails for accurate alignment of entrances with cars. Where possible, delay final adjustment of sills and doors until car is operable in shaft. Reduce clearances to minimum, safe, workable dimension at each landing.
- F. Leveling Tolerance: 1/8 inch (3 mm), up or down, regardless of load and direction of travel.
- G. Set sills flush with finished floor surface at landing. Fill space under sill solidly with nonshrink, nonmetallic grout.

3.3 FIELD QUALITY CONTROL

- A. Acceptance Testing: On completion of elevator installation and before permitting use (either temporary or permanent) of elevators, perform acceptance tests as required and recommended by ASME A17.1 and governing regulations and agencies. All tests shall be witnessed by a qualified elevator inspector (QEI) retained by the Owner.
- B. Operating Test: Load elevators to rated capacity and operate continuously for 30 minutes over full travel distance, stopping at each level and proceeding immediately to the next. Record temperature rise of elevator machines during 30-minute test period. Record failure of elevators to perform as required.
 - 1. Perform operating test specified above on one elevator of each type, capacity, speed, and travel distance.
- C. Advise Owner, Architect, and authorities having jurisdiction in advance of dates and times tests are to be performed on elevators.

3.4 DEMONSTRATION

- A. Instruct Owner's personnel in proper use, operation, and daily maintenance of elevators. Review emergency provisions, including emergency access and procedures to be followed at time of operational failure and other building emergencies. Train Owner's personnel in procedures to follow in identifying sources of operational failures or malfunctions. Confer with Owner on requirements for a complete elevator maintenance program.
- B. Make a final check of each elevator operation with Owner's personnel present and before date of Substantial Completion. Determine that operation systems and devices are functioning properly.

3.5 PROTECTION

- A. Temporary Use: Do not use elevators for construction purposes unless cars are provided with temporary enclosures, either within finished cars or in place of finished cars, to protect finishes from damage.
1. Provide full maintenance service by skilled, competent employees of elevator Installer for elevators used for construction purposes. Include preventive maintenance, repair or replacement of worn or defective components, lubrication, cleaning, and adjusting as required for proper elevator operation at rated speed and capacity. Use same parts and supplies as used in the manufacture and installation of original equipment.
 2. Provide protective coverings, barriers, devices, signs, and other procedures to protect elevators. If, despite such protection, elevators become damaged, engage elevator Installer to restore damaged work so no evidence remains of correction work. Return items that cannot be refinished in the field to the shop, make required repairs and refinish entire unit, or provide new units as required.
 3. Provide services of an elevator operator to operate the elevator during construction for construction purposes once temporary enclosures are in place. Cost of operator's services shall be borne by Contractor.

END OF SECTION 142100

SECTION 144200 - WHEELCHAIR LIFTS

PART 1 - GENERAL

1.1 SUMMARY

- A. This Section includes lift assemblies of the following type and application:
 - 1. Type: Unenclosed, straight-through platform lift.
- B. Electrical service to each lift, including fused disconnect switch, is specified in Division 26 sections.

1.2 DEFINITIONS

- A. Lift assembly is defined to include driving machines, platforms, access panels, guide rails, drive system, buffers (if any), signals, control systems, electrical wiring, and devices necessary to provide specified or Code-required performance operations, safety, or security of complete lift assembly. Include self-supporting lift structure as indicated.

1.3 SUBMITTALS

- A. Product Data: Manufacturer's complete technical product data and installation instructions for each item specified, indicating capacities, dimensions, performances, operations, safety features, controls, finishes, and similar information.
- B. Shop Drawings: Plans, elevations, and details showing interfaces with other work including loading on structure, together with indication of required clearances.
- C. Maintenance Manuals: Bound manuals, with operating and maintenance instructions, parts listing with sources indicated, recommended parts inventory listing, emergency instructions, and similar information.
- D. Inspection and Acceptance Certificates: Include operating permits as required by governing authorities for normal, unrestricted use of lifts.

1.4 QUALITY ASSURANCE

- A. Manufacturer Qualifications: The manufacturer shall have not less than 10 years experience in the design and fabrication of vertical wheelchair lifts.
- B. Installer Qualifications: Either the lift manufacturer or an installer approved by the manufacturer.
- C. Accessibility Requirements: Comply with applicable provisions in the U.S. Architectural & Transportation Barriers Compliance Board's ADA-ABA Accessibility Guidelines and ICC A117.1.

- D. Regulatory Requirements: Comply with ASME A18.1, "Safety Standard for Platform Lifts and Stairway Chairlifts."
- E. Design Concept: The drawings indicate the size, configurations, and dimensional requirements of the vertical wheelchair lifts required and are based on the specific type and model indicated. Wheelchair lifts by other manufacturers may be considered provided deviations in dimensions and configurations of components are minor and do not change the design concept as judged by the Architect. The burden of proof of equality is on the proposer.

1.5 INSTRUCTION AND MAINTENANCE

- A. Instruct Owner's personnel in proper operation and maintenance of lift. Train Owner's personnel in procedures to follow in identifying sources of operational failures or malfunctions.
- B. Maintenance: Starting at date of Substantial Completion, provide full maintenance of units for a period of 12 months on a quarterly site visit/preventive maintenance basis. Correct operational imperfections and restore or replace defective or deteriorated components and finishes. Use only genuine parts, components, and supplies as used in the manufacture and installation of original equipment.

1.6 WARRANTY

- A. Warranty: Provide special project warranty, signed by Contractor, Installer and Manufacturer, agreeing to replace/repair/restore defective materials and workmanship of wheel chair lift during warranty period. "Defective" is hereby defined to include, but not by way of limitation, operation or control system failures, performances below required minimums, excessive wear, unusual deterioration or aging of materials or finishes, unsafe conditions, the need for excessive maintenance, abnormal noise or vibration, and similar unusual, unexpected and unsatisfactory conditions.
 - 1. The warranty period is 2 years starting on date of substantial completion.
- B. The warranty shall not deprive the Owner of other rights the Owner may have under other provisions of the Contract Documents and will be in addition to and run concurrent with other warranties made by the Contractor under requirements of the Contract Documents.

PART 2 - - PRODUCTS

2.1 MANUFACTURERS

- A. Manufacturers: Subject to compliance with requirements, provide Basis of Design Products by Garaventa, or approved equal by one of the following:
 - 1. American Stair-Glide Corporation.
 - 2. The Cheney Company, Inc.
 - 3. National Wheel-O-Vator Co, Inc.

2.2 MATERIALS

- A. Steel Plates, Shapes, and Bars: ASTM A 36 (ASTM A 36M).
- B. Steel Tubing: Either cold- or hot-formed steel tubing.
 - 1. Cold-Formed Steel Tubing: ASTM A 500.
 - 2. Hot-Formed Steel Tubing: ASTM A 501.
- C. Steel Pipe: ASTM A 53; standard weight (Schedule 40), unless otherwise indicated or required by structural loads.
- D. Carbon-Steel Sheet: Either cold- or hot-rolled, commercial-quality carbon steel.
 - 1. Cold Rolled: ASTM A 366 (ASTM A 366M).
 - 2. Hot Rolled: ASTM A 569 (ASTM A 569M).
- E. Zinc-Coated (Galvanized) Steel Sheet: ASTM A 653, G90 (ASTM A 653M, Z275) coating designation, commercial quality.
- F. Inserts: Furnish required concrete and masonry inserts and similar anchorage devices for installing structural members, guide rails, machines, and other lift components where installation of devices is specified in another Specification Section.
- G. Expansion Anchors: Anchor-bolt-and-sleeve assembly of material indicated below with capability to sustain, without failure, a load equal to 10 times the load imposed as determined by testing per ASTM E 488 conducted by a qualified independent testing agency.
 - 1. Material: Carbon-steel components, zinc plated to comply with ASTM B 633, Class Fe/Zn 5.
- H. Nonshrink, Nonmetallic Grout: Factory-packaged, nonstaining, noncorrosive, nongaseous grout complying with ASTM C 1107.

2.3 UNENCLOSED, STRAIGHT THROUGH PLATFORM WHEELCHAIR LIFTS

- A. Basis of Design Product: Genesis Opal Model GVL-OP-42 by Garanventa, Lift, or approved equal.
- B. Systems and Machinery: Provide lift system to comply with the following requirements:
 - 1. Rated Capacity: 750 pounds.
 - 2. Rated Speed: 10 ft. per minute.
 - 3. Power Supply: 120 VAC, 20 Amp, 1 phase, 60 Hertz.
 - 4. System Control Voltage: 24 VAC.
 - 5. Drive Mechanism: Leadscrew drive. Self-lubricating acme screw drive
 - 6. Motor: 2 HP.

7. Platform: Minimum 12 gauge steel, with skid-resistant surface finish.
 8. Platform Size: 36" x 48-7/8" (Standard).
 9. Platform Configuration: Straight through, with front and rear openings.
 10. Platform Side Panels: Full height solid infill panels fabricated of not less than 16 gauge galvanized steel.
 11. Door/Gate: 36" wide door with power door/gate operator and interlock.
 12. Grab Rail: Provide a grab rail on the platform in accordance with ANSI requirements for commercial applications.
 13. Inserts: Provide required concrete inserts and similar anchorage devices required for the installation of structural members, guide rails, machines, and other components. Installation of such inserts and devices is specified in other divisions of the specifications.
 14. Vertical Rise: 45 inches maximum lifting height.
- C. Control System: Provide constant pressure up-down switch which is keylocked and meets the requirements of ASME A18.1, "Safety Standard for Platform Lifts and Stairway Chairlifts."
1. Provide solid-state control system to greatest extent of availability, supplemented with electromechanical equipment.
 2. Electrical Interlocks: Provide unit with interlocks at all gates and doors (top, platform, and bottom) which will prevent operation of the lift unless gates/doors are secured.
 3. Leveling Tolerance: Provide terminal stopping system at each extreme of travel and adjust to maintain level tolerance within 1/8 inch regardless of load size or direction of travel.
 4. Limit Switches: Provide at both top and bottom extremes of travel.
 5. Obstruction Sensors: Provide sensors to cut power and stop unit in the event of contact with foreign object within pathway of travel. Comply with Code.
 6. Safety Device: Provide safety device to stop platform in event of overspeed condition or of breakage or slackening of suspension of support means.
 7. Manual Lowering: Provide means and tool to manually lower platform in case of malfunction or power loss.
- D. Station and Platform Controls:
1. Lower Landing Call Station: Push button wall mount with key operation and automatic controls.
 2. Upper Landing Call Station: Push button wall mount with key operation and automatic controls.
 3. Emergency Telephone: Platform shall be equipped with ADA compliant integrated telephone with a stainless-steel faceplate. Telephone shall operate in the event of power failure. A telephone line shall be supplied to the lift site as specified under Division 26
- E. Ramps: Provide a stationary ramp of 16 gauge galvanized steel sheet with a slip resistant finish at lower landing for access onto the platform.

2.4 FINISHES

- A. General: Comply with NAAMM's "Metal Finishes Manual for Architectural and Metal Products" for recommendations relative to application and designations of finishes.
- B. Steel and Iron Finishes: Prepare and finish iron and steel, including galvanized steel, as follows:
 - 1. Prepare uncoated ferrous-metal surfaces to comply with SSPC-SP 3, "Power Tool Cleaning," or SSPC-SP 6, "Commercial Blast Cleaning," followed by a conversion coating of type suited to organic coating applied over it.
 - 2. Prepare galvanized steel surfaces by removing dirt, grease, and other contaminants followed by a conversion coating of type suited to organic coating applied over it. Clean welds, mechanical connections, and abraded areas; and apply galvanizing repair paint to comply with ASTM A 780.
 - 3. Powder-Coated Finish: Immediately after cleaning and pretreating, apply manufacturer's standard, polyester, powder coating complying with AAMA 605.2.
 - a. Color and Gloss: As selected by the Architect.

PART 3 - - EXECUTION

3.1 INSTALLATION

- A. General: Comply with manufacturer's instructions and recommendations and approved shop drawings for work during installation.
- B. Code Compliance: The wheelchair lift installations shall conform to all applicable regulatory requirements including ASME A17.1 and ASME A18.1
- C. Alignment: Coordinate runway doors with platform travel and positioning, for accurate alignment and minimum clearance between platform, runway door, sills, and door frame at each landing.
- D. Position sills accurately with floors or counters, raised slightly above adjoining surface to minimize intrusion of dirt and spillage into runway. Coordinate with other trades to ensure that sills, or lower member of frames, are solidly grouted (no voids) with a nonstaining, nonshrinking grout.
- E. Adjust stops for accurate leveling at each landing, within specified tolerances.
- F. Lubricate operating parts of lift, including drive mechanism, guide rails, safety devices, and hardware.

3.2 FIELD QUALITY CONTROL

- A. Test operate lift continuously between lowest and highest landings served, lifting full rated capacity load for a minimum period of 30 minutes. Readjust stops and other devices and signal equipment for accurate landings and operation of system after completion of test.

- B. Perform tests in compliance with ASME A17.1 or A18.1 and as required by authorities having jurisdiction.
- C. Perform tests with Architect, Owner, and Contractor present.

3.3 DEMONSTRATION

- A. Instruct Owner's maintenance personnel in the proper use, operation, and maintenance of lifts. Review emergency provisions, including access and procedures to be followed in checking for sources of operational failures or malfunctions. Confer with Owner on requirements for a complete maintenance program.
- B. Check each lift operation with Owner's maintenance personnel present before time of Substantial Completion. Determine that control system, operating components, and safety devices are functioning properly.

END OF SECTION 144200