

NEW COMMUNITY SCHOOL 35 AT ST DENIS SITE

YONKERS JOINT SCHOOL CONSTRUCTION BOARD

121 McLean Avenue, Yonkers, NY 10705



KG+D . ARCHITECTS PC
285 MAIN STREET MOUNT KISCO, NEW YORK, 10549
P:914.666.5900 KGDARCHITECTS.COM



83 Wooster Heights Road | Suite 200
Lisle Farm Corporate Park | Danbury, CT 06810
(203) 490-1140 | www.dsleg.com

NY SED PROJECT CONTROL NO.
66-23-00-01-0-346-001

CONSTRUCTION DOCUMENTS

OWNERSHIP, USE AND ALTERATION OF DOCUMENTS:

The Client acknowledges that the documents, drawings, specifications including electronic media files are instruments of The Di Salvo Engineering Group's services and shall remain the property of The Di Salvo Engineering Group. The Client or any person or entity that acquires or obtains the drawings and specifications from or through The Client shall not use them on any other project, shall not modify, alter or change the drawings and specifications without written authorization from The Di Salvo Engineering Group. Furthermore, The Client agrees to the fullest extent permitted by law to indemnify and hold harmless The Di Salvo Engineering Group, its officers, directors and employees from any and all claims, suits, liability, demands or costs, including attorney fees arising out of or resulting therefrom.

SCOPE OF WORK RELATED TO SECTIONS AND DETAILS:
Work shown as "Typical Details" apply throughout the project as required.
Work shown as "Sections" shall be considered to apply for the same and similar conditions in the building.

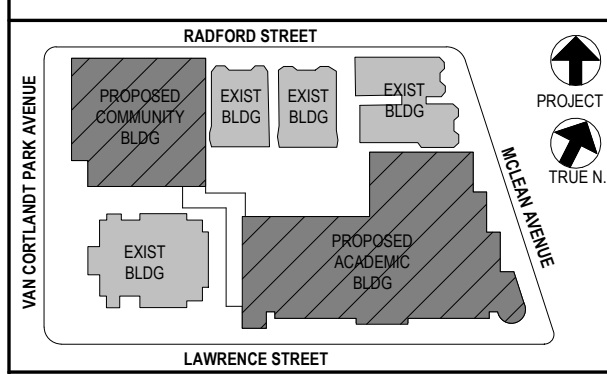

NOTE: ALL DESIGN, SPECIAL ARRANGEMENTS AND PLANS INDICATED OR REPRESENTED BY THIS DRAWING ARE OWNED BY AND ARE THE PROPERTY OF ARCHITECTS KG+D AND/OR ARCHITECTS PC. NO PART OF THIS DRAWING IS TO BE REPRODUCED OR USED FOR ANY OTHER PROJECT WITHOUT THE WRITTEN PERMISSION OF ARCHITECTS KG+D AND/OR ARCHITECTS PC.

WRITTEN DIMENSIONS ON THIS DRAWING SHALL HAVE PRECEDENCE OVER UNWRITTEN DIMENSIONS CONTAINED THEREIN. ALL DIMENSIONS SHALL BE IN UNITS OF FEET AND INCHES UNLESS OTHERWISE SPECIFIED. DIMENSIONS SHALL BE TO FACE UNLESS OTHERWISE SPECIFIED. DIMENSIONS SHALL BE TO FACE UNLESS OTHERWISE SPECIFIED. DIMENSIONS SHALL BE TO FACE UNLESS OTHERWISE SPECIFIED. DIMENSIONS SHALL BE TO FACE UNLESS OTHERWISE SPECIFIED.

ALTERATIONS BY ANY PERSON IN ANY WAY OF ANY ITEM CONTAINED ON THIS DOCUMENT, UNLESS ACTING UNDER THE DIRECTION OF THE LICENSED ARCHITECT WHOSE PROFESSIONAL SEAL IS AFFIXED HERETO, IS A VIOLATION OF TITLE 16, SECTION 26-3.0 OF THE NEW YORK STATE LAW. COPYRIGHT 2020, KG+D ARCHITECTS PC AND ARCHITECTS PC. ALL RIGHTS RESERVED.

Professional Seal

No.	Date	Issue
4	11/01/21	ISSUE FOR BID
3	07/14/21	CONSTRUCTION DOCS - NYSED
2	12/15/20	DESIGN DEVELOPMENT
1	08/31/20	SCHEMATIC DESIGN

Sheet Title

FRAMING SECTIONS

Job No.	20142.00	Date	10/30/2020
Scale	AS NOTED	Eng'n'r / Checked	Author / Checker
Sheet Number	S313		

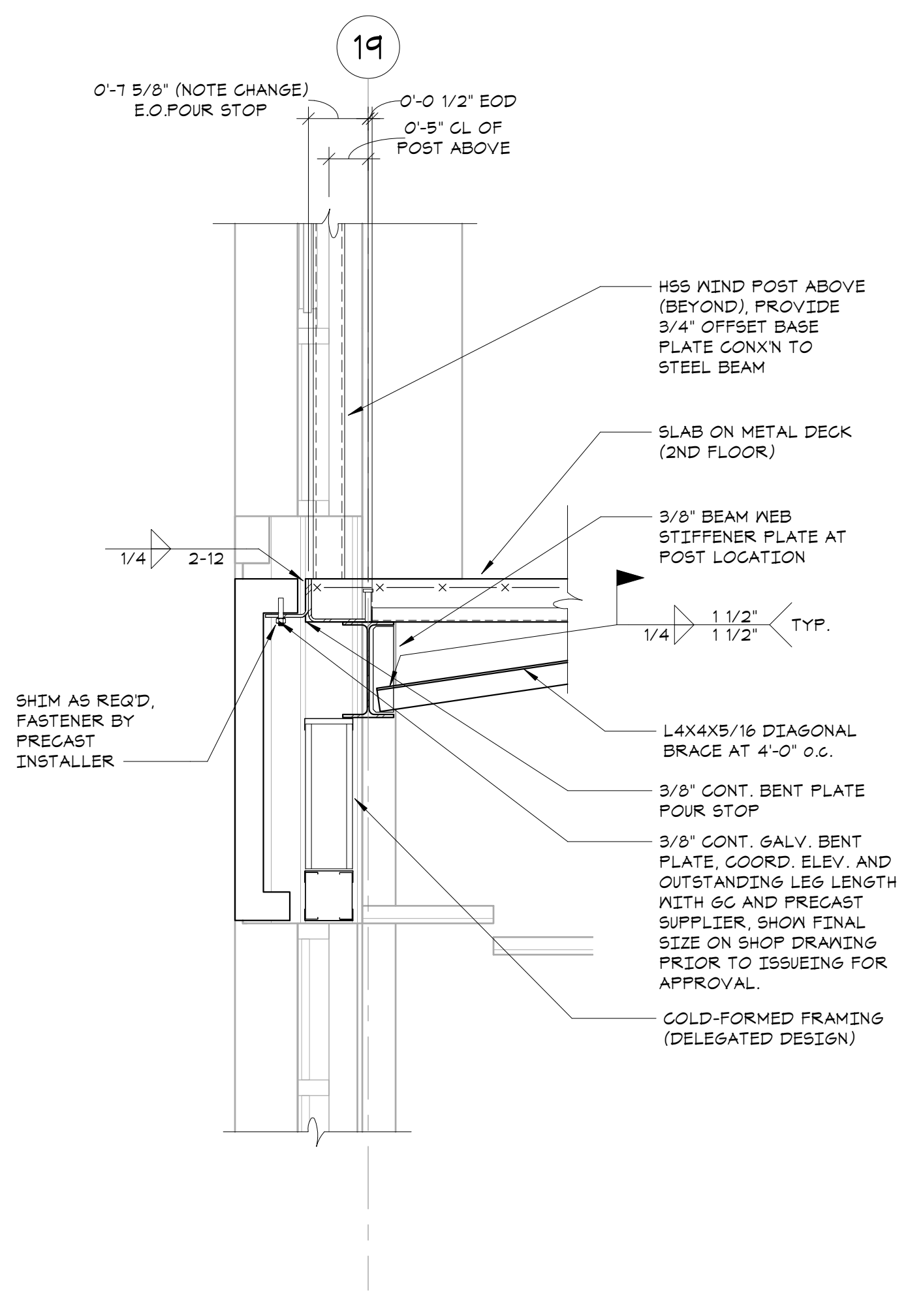

1 SECTION
3/4" = 1'-0"

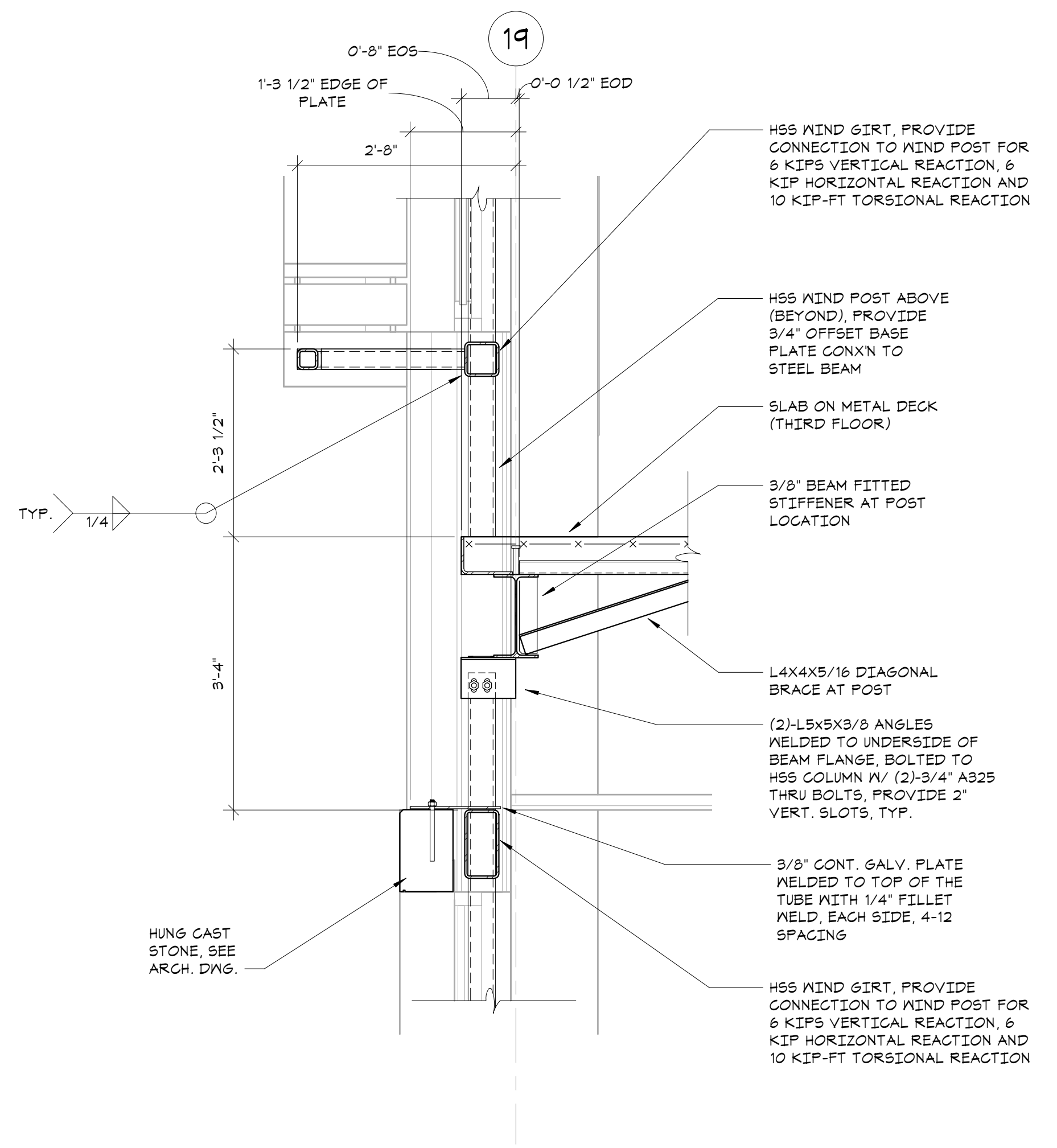

2 SECTION
3/4" = 1'-0"

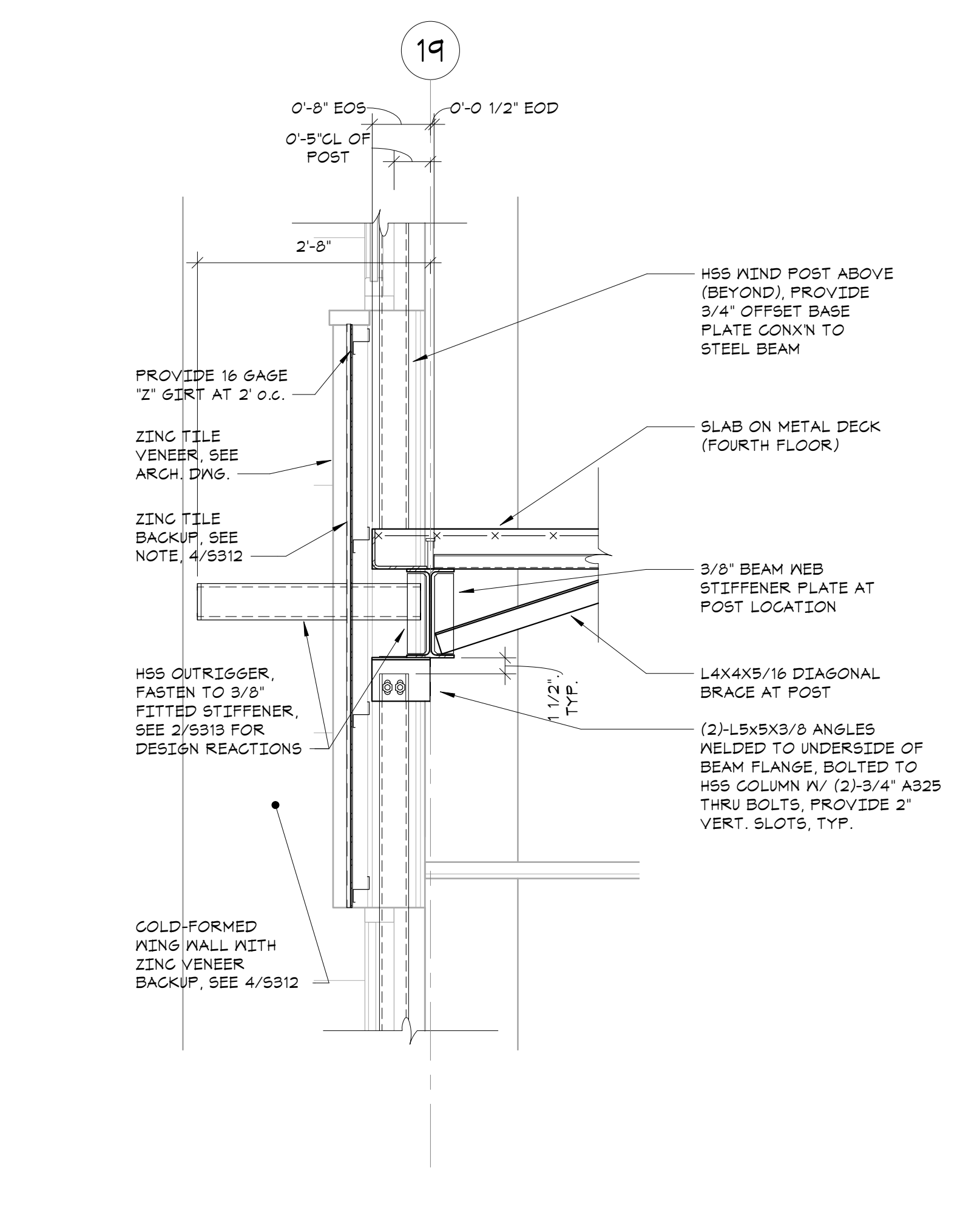

3 SECTION
3/4" = 1'-0"

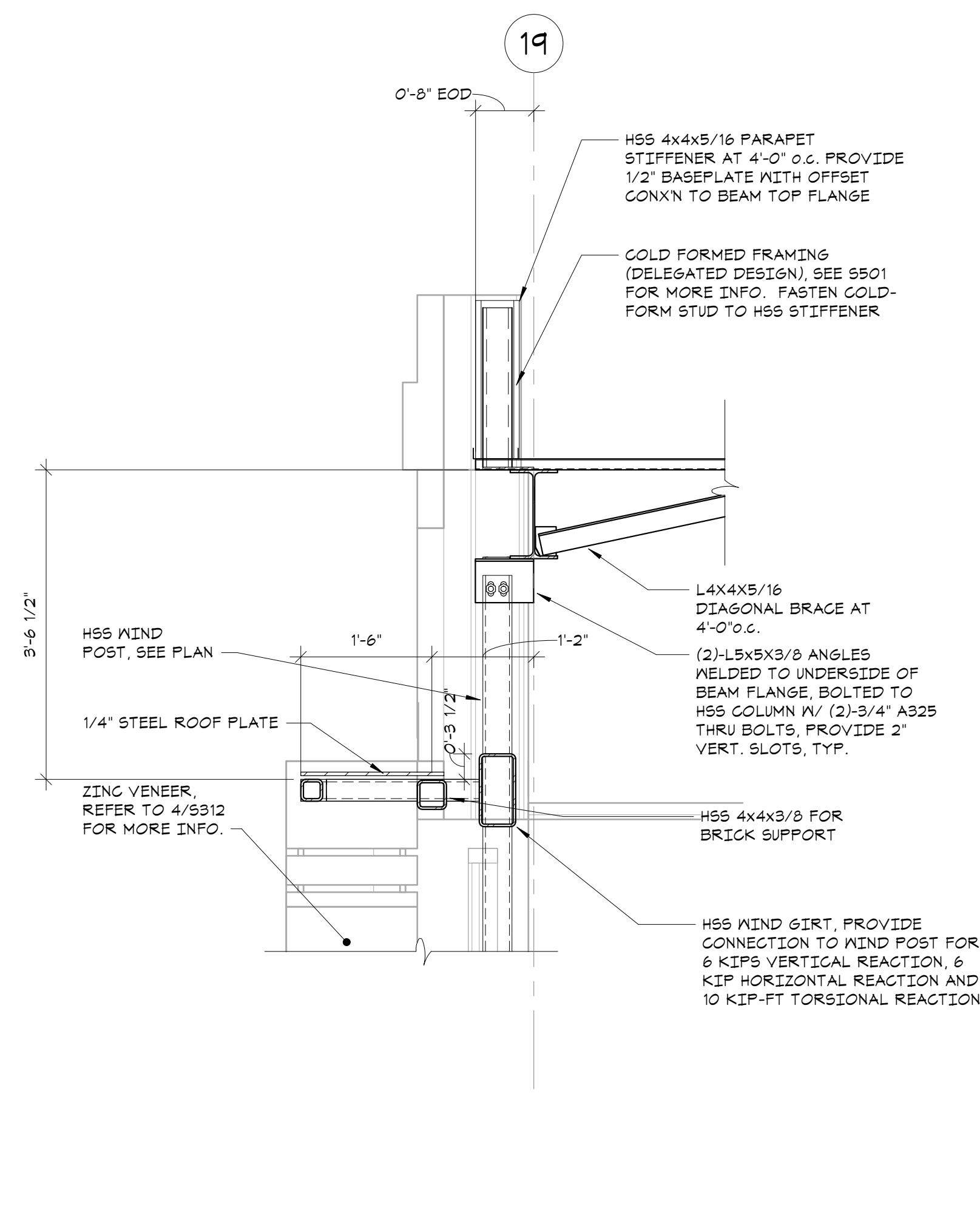

4 SECTION
3/4" = 1'-0"

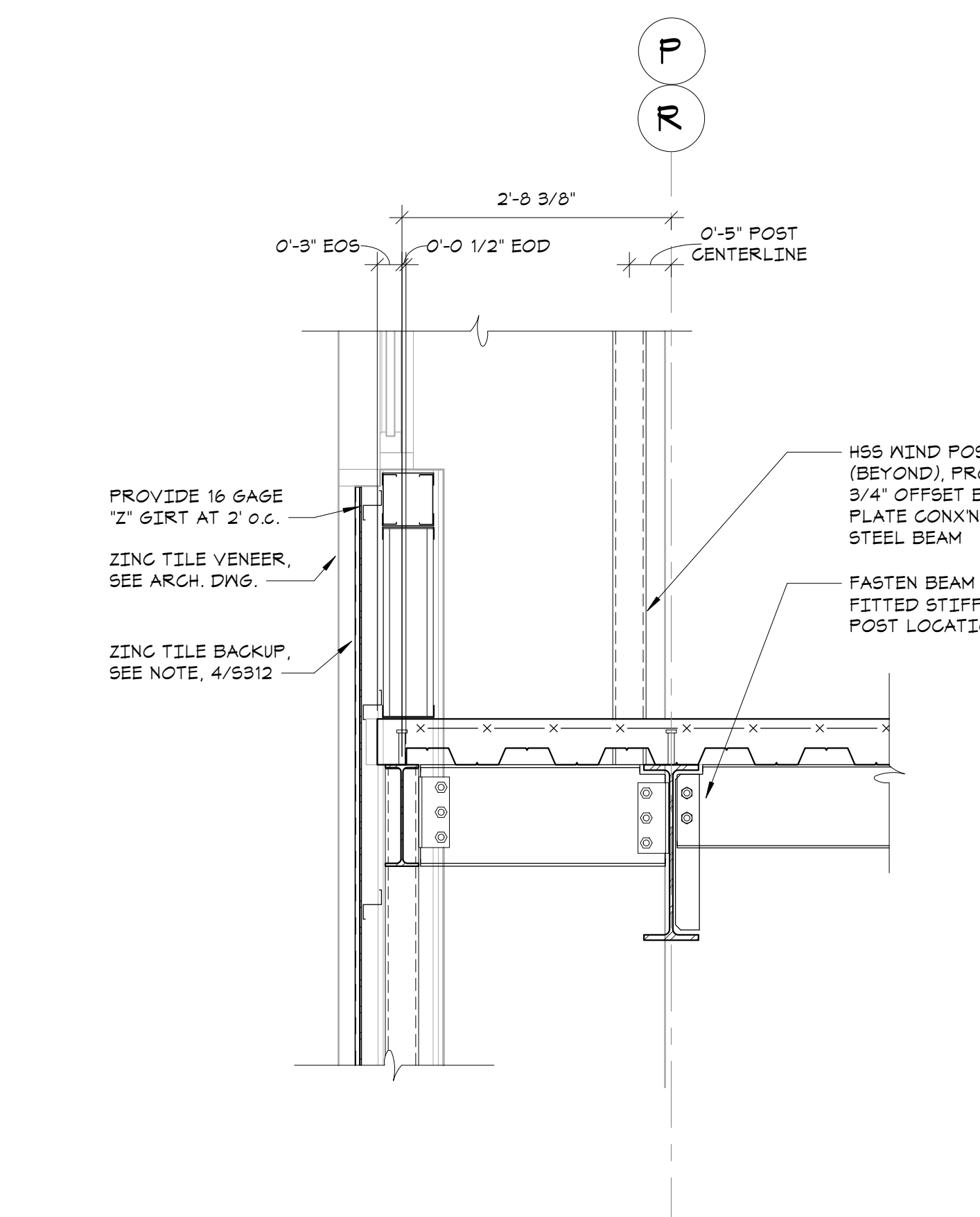

5 SECTION
3/4" = 1'-0"

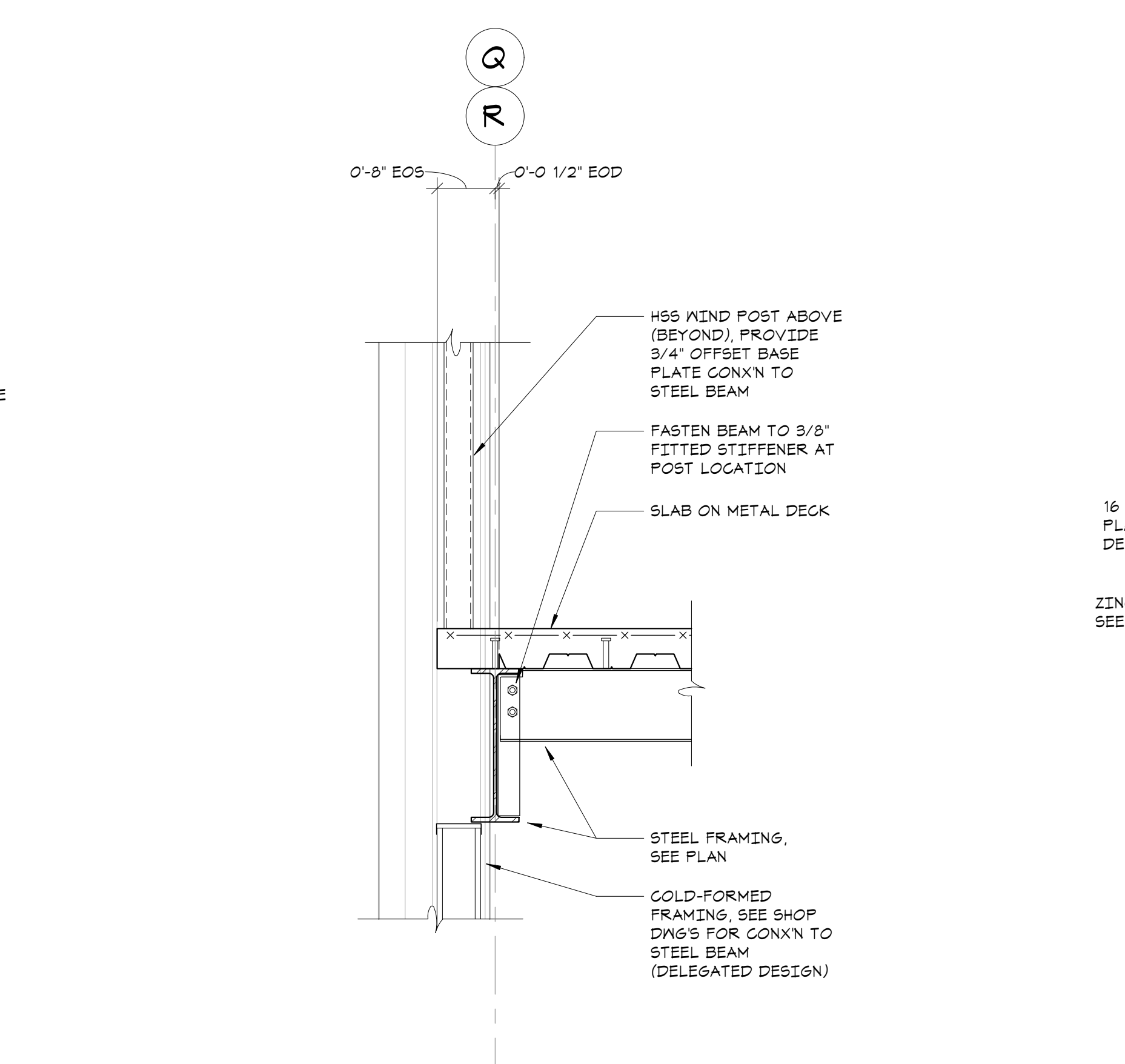

6 SECTION
3/4" = 1'-0"

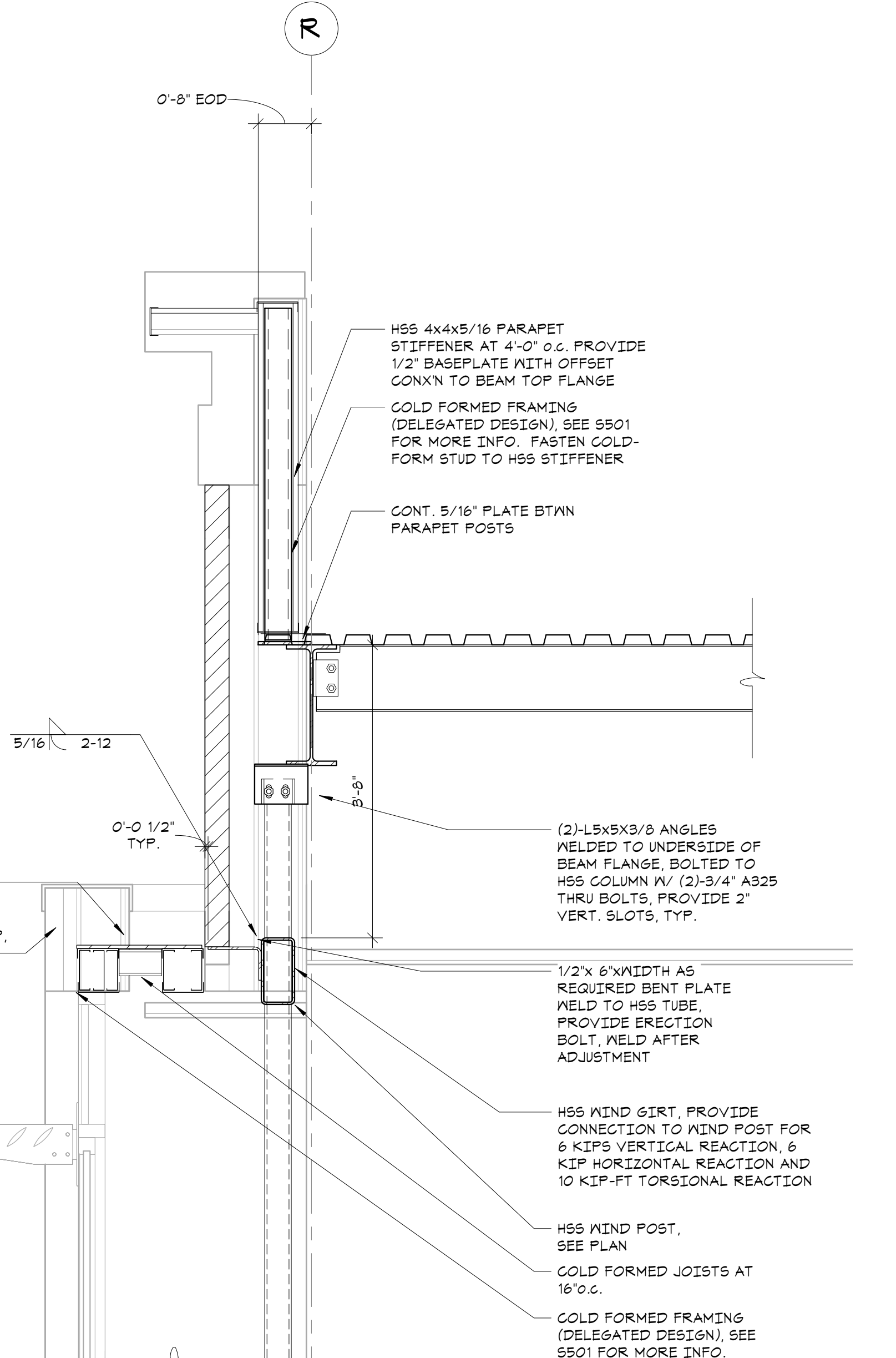

7 SECTION
3/4" = 1'-0"

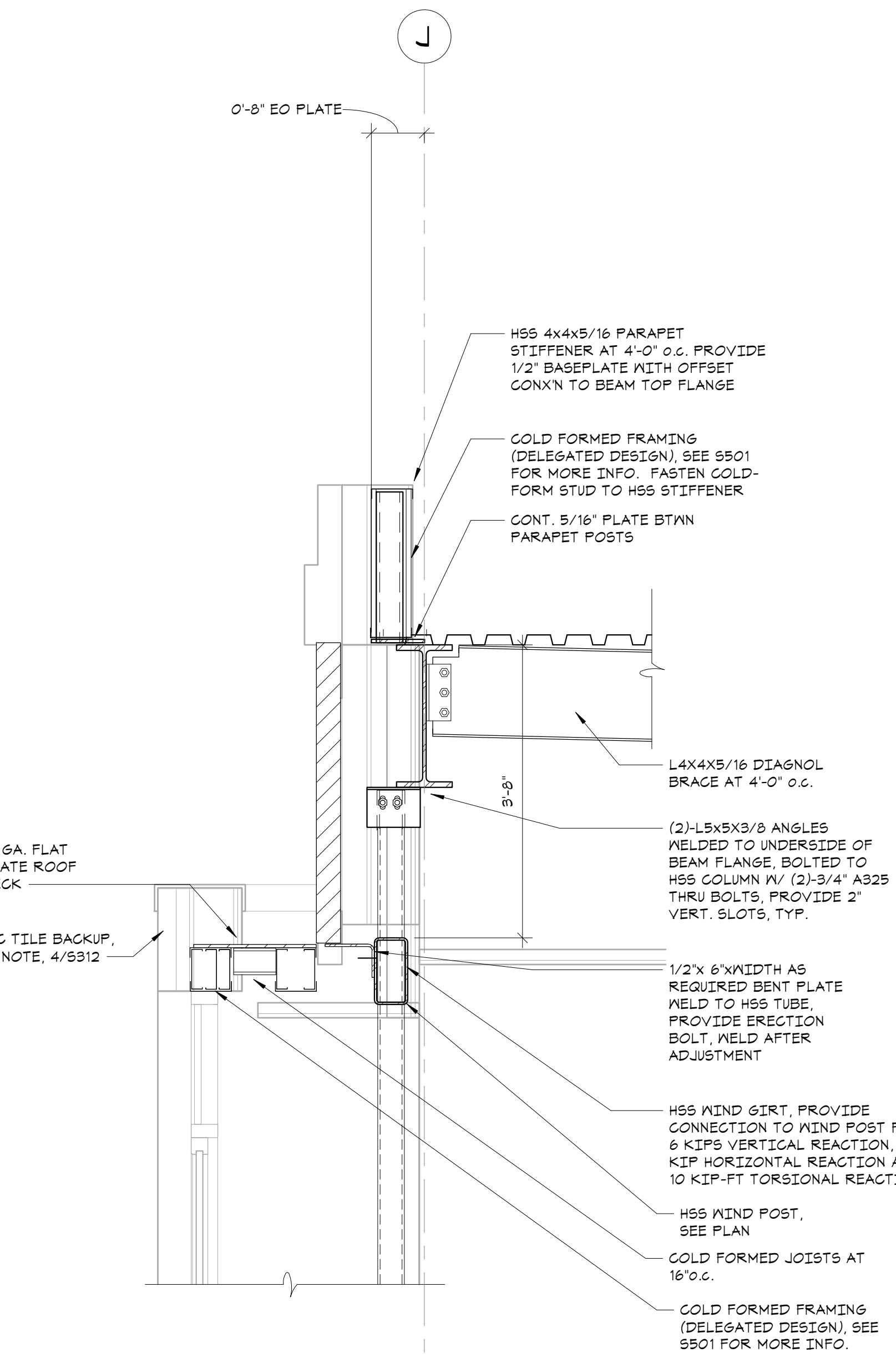

8 SECTION
3/4" = 1'-0"