

LIGHT POLE BASE SCHEDULE
 DIMENSIONS IN INCHES

TYPE	A (DIAMETER)	B (DEPTH)
A	12"	36"
B	18"	48"
C	24"	60"
D	24"	84"

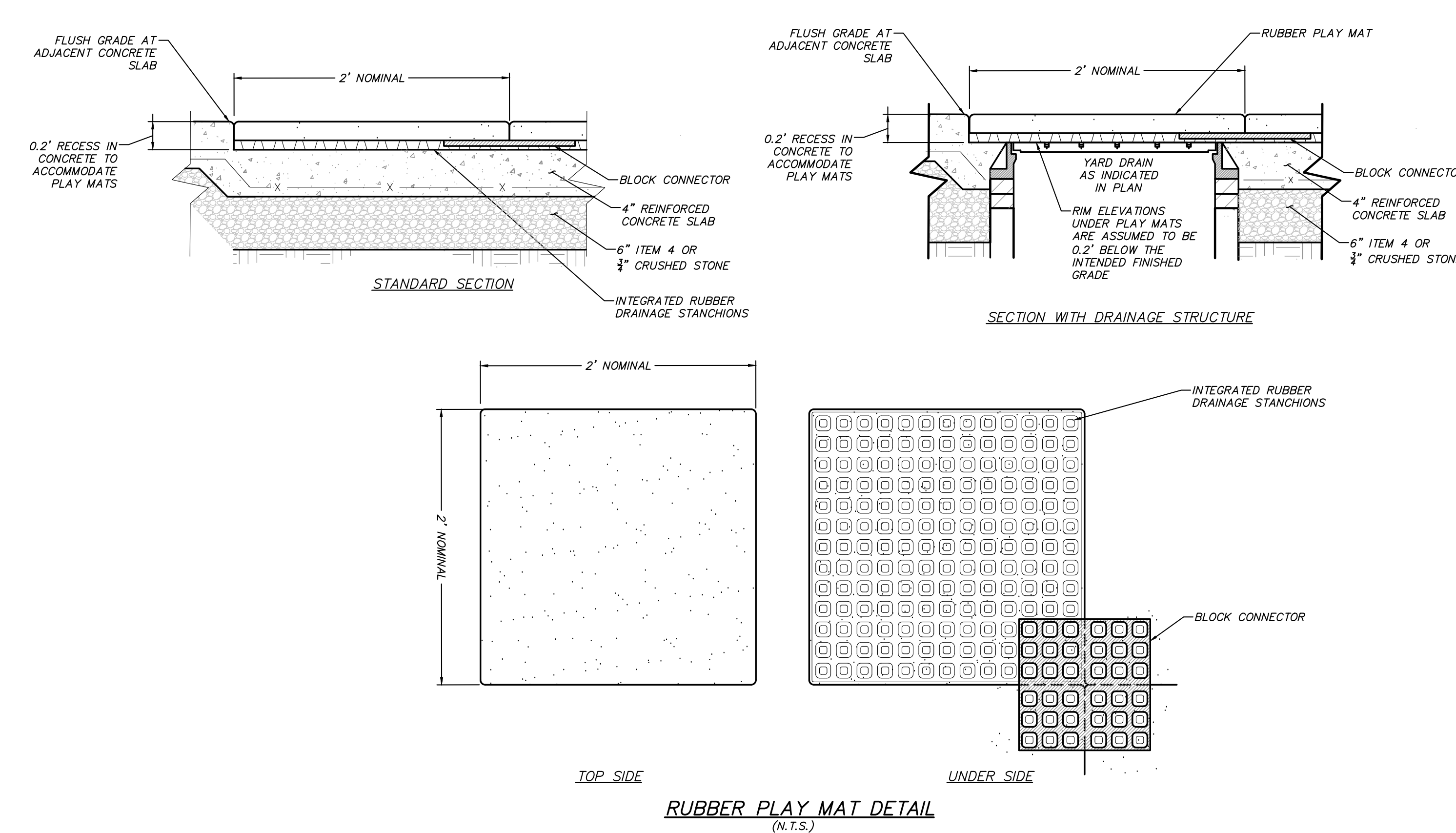

NOTE: ALL CIVIL, GEOTECH, ARCHITECTURE AND PLANS INDICATED OR REPRESENTED BY THIS DRAWING ARE OWNED BY AND ARE THE PROPERTY OF KAYEYR, GARDNER & DAVENSON ARCHITECTS, P.C. NO PARTS HEREOF CREATED, REVISED OR DEVELOPED FOR USE ON AND IN CONNECTION WITH THE SPECIFIC PROJECT NAME OR FOR OTHER PROJECTS, DRAWINGS, PERMITS OR PLANS SHALL BE USED BY OR DISCLOSED TO ANY PURPOSE WHATSOEVER WITHOUT THE WRITTEN PERMISSION OF KAYEYR, GARDNER & DAVENSON ARCHITECTS, P.C.
 WRITTEN DIMENSIONS ON THIS DRAWING SHALL HAVE PRECEDENCE OVER SCALE DIMENSIONS. CONTRACTOR SHALL VERIFY AND BE RESPONSIBLE FOR ALL DIMENSIONS AND CONDITIONS ON THE JOB AND THIS OFFICE MUST BE NOTICED OF ANY VARIATIONS FROM CONDITIONS AND CONDITIONS SHOWN BY THESE DRAWINGS. SHOP DETAILS MUST BE SUBMITTED TO THIS OFFICE FOR APPROVAL BEFORE PROCEEDING WITH FABRICATION.
 LEGAL NOTICE: ALTERATIONS BY ANY PERSON IN ANY WAY OF ANY ITEM CONTAINED ON THIS DOCUMENT UNLESS ACTING UNDER THE DIRECTION OF THE LICENSED ARCHITECT WHOSE PROFESSIONAL SEAL IS AFFIXED HERETO, IS A VIOLATION OF TITLE 16, SECTION 1703 OF NEW YORK STATE LAW.
 © COPYRIGHT KAYEYR, GARDNER & DAVENSON, P.C.
 ALL RIGHTS RESERVED.

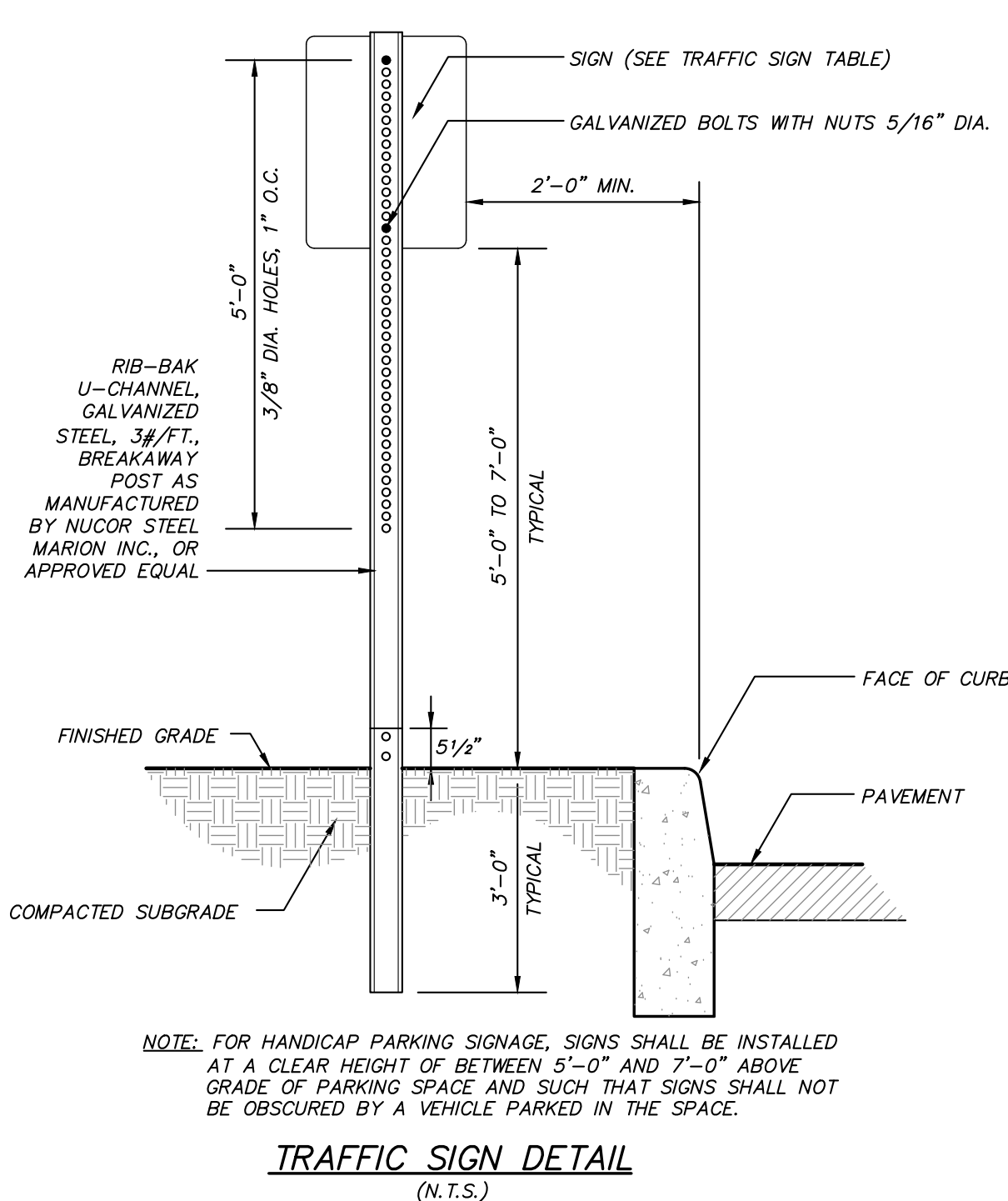
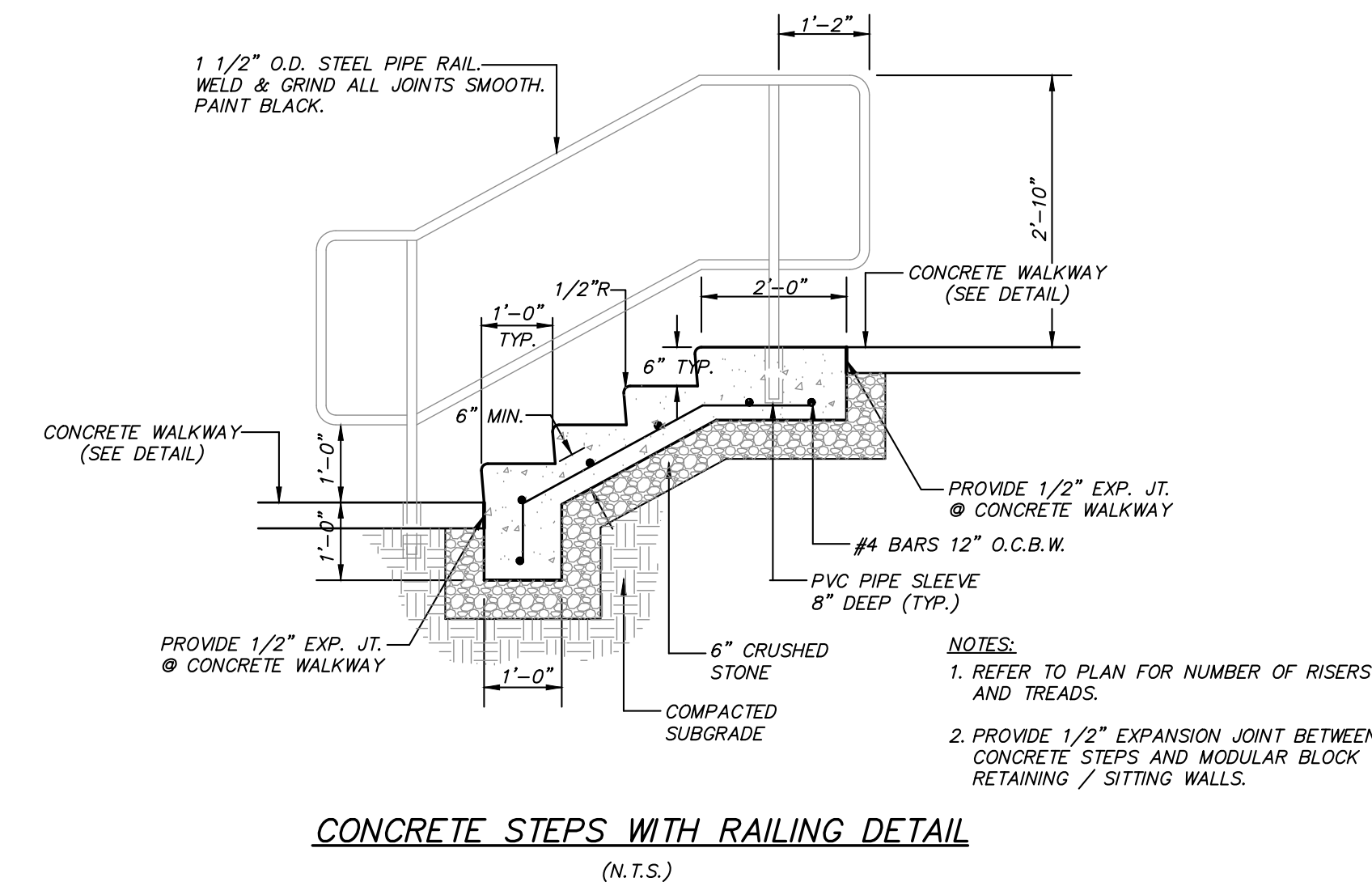
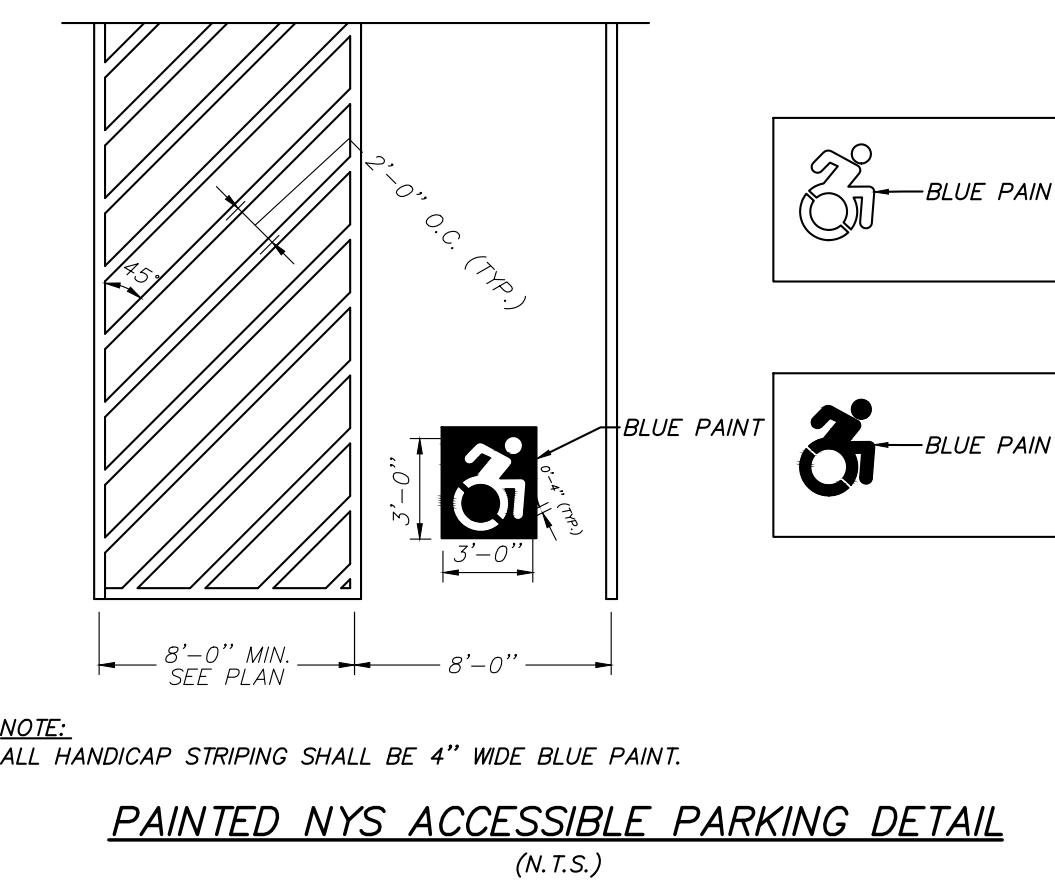
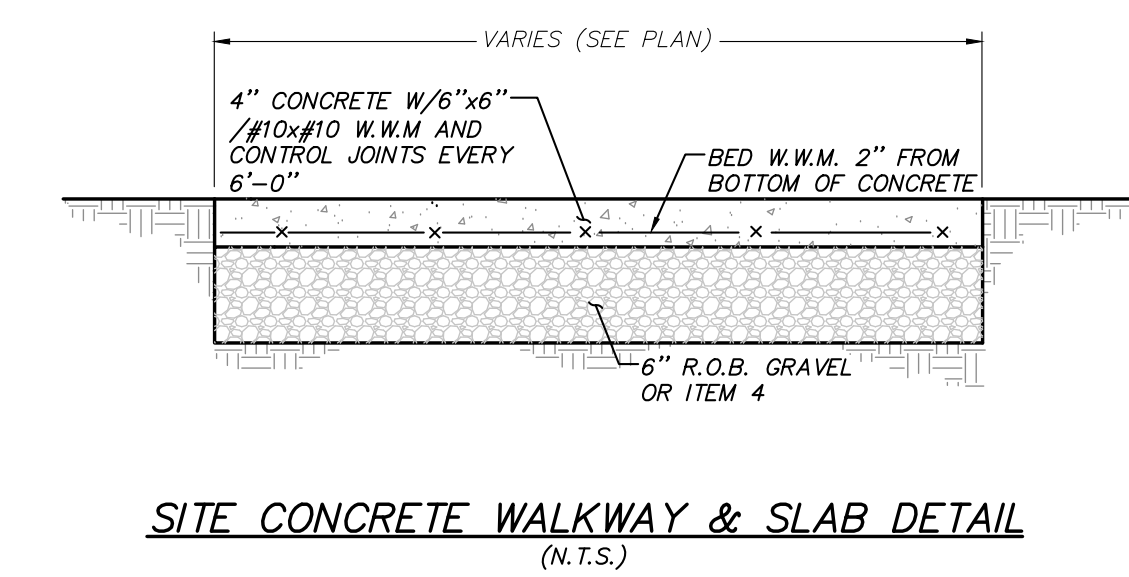
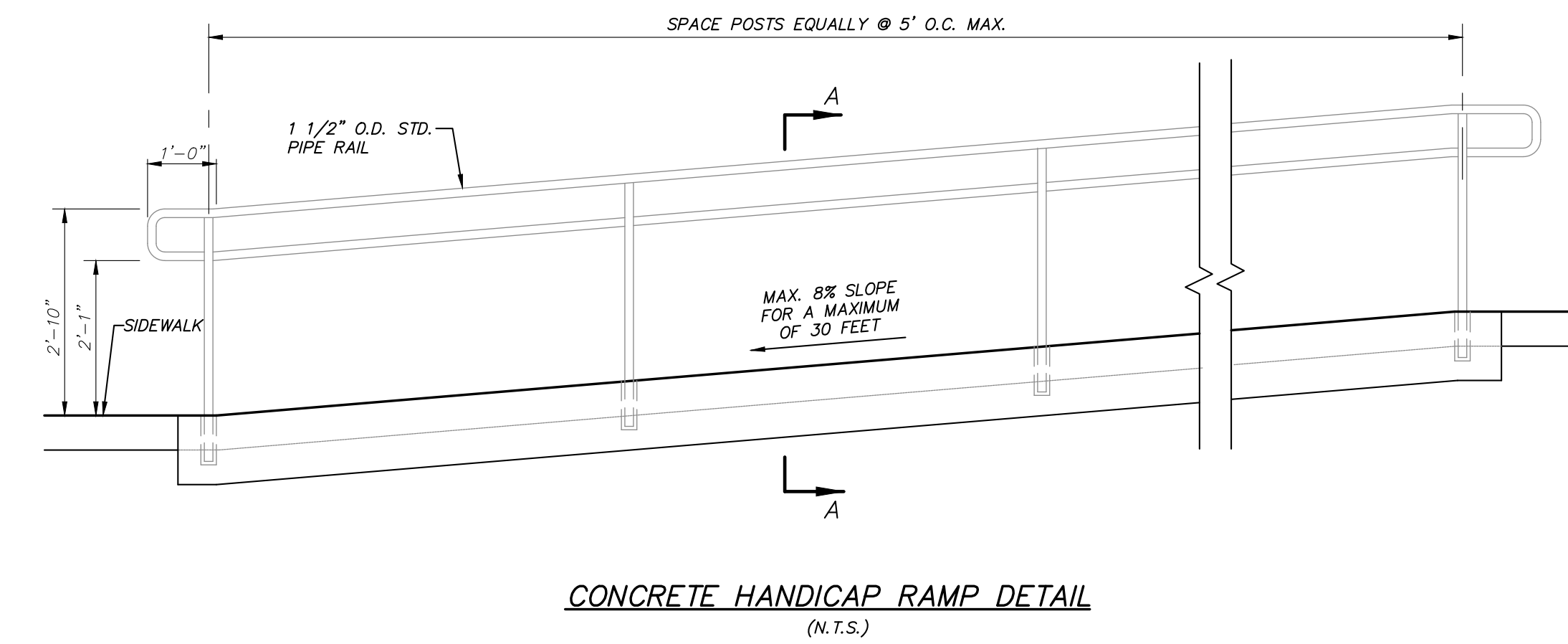
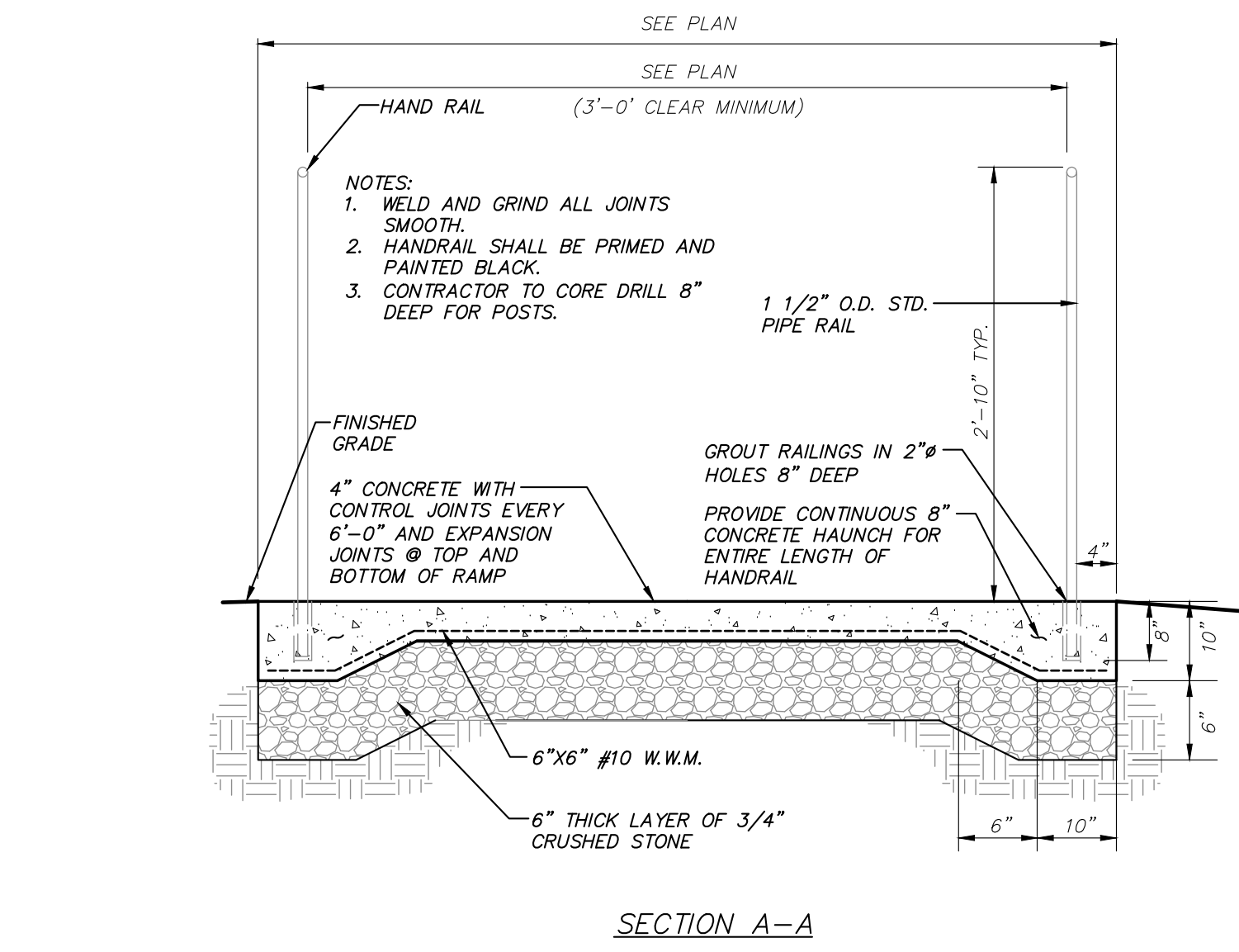
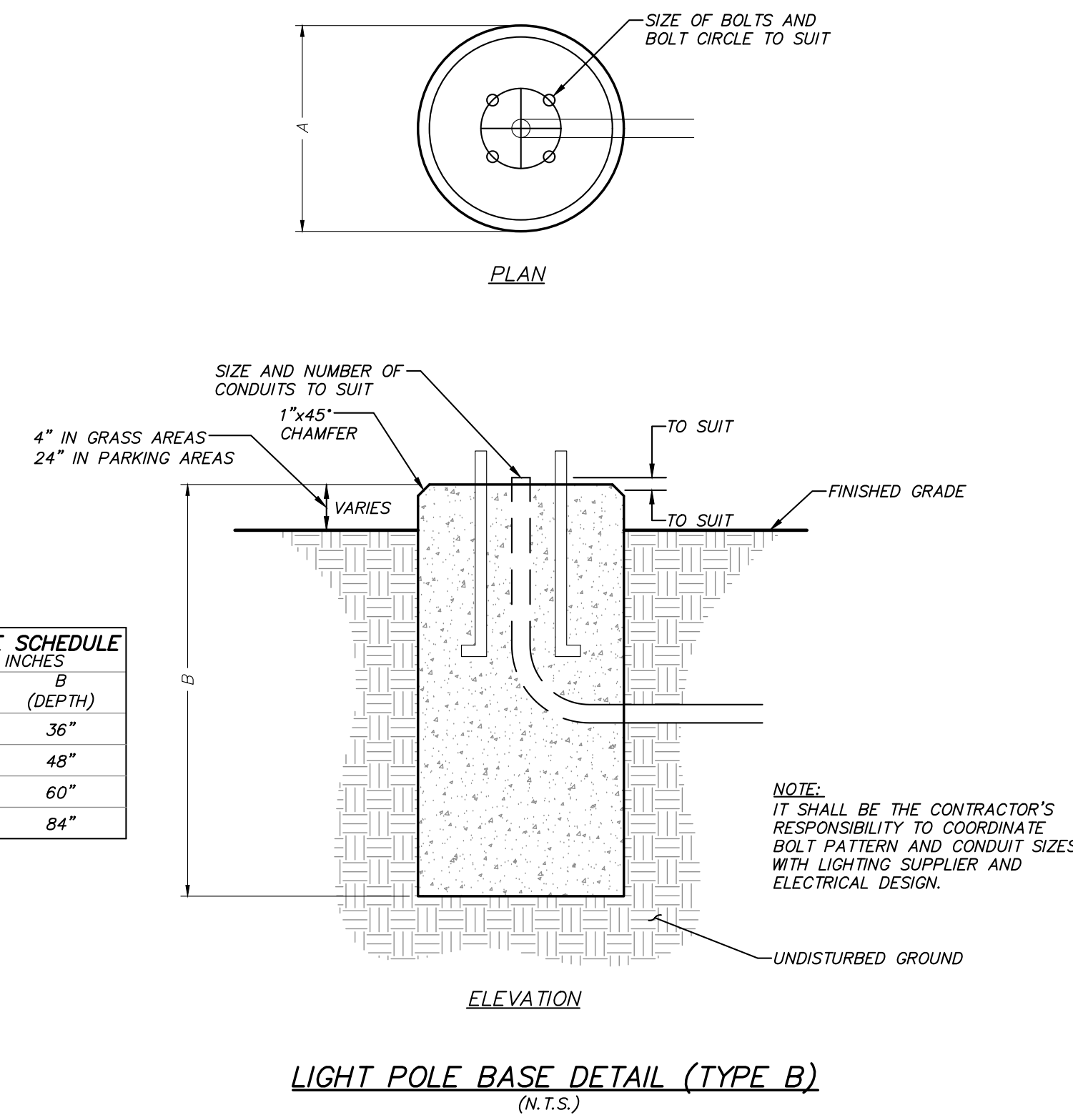

No.	Date	Issue
11/01/2021	ISSUE FOR BID	
08/24/2021	NYSID ADDENDUM 1	
07/14/2021	CONST. DOCS - FOR NYSID	
12/15/2020	DESIGN DEVELOPMENT	
08/31/2020	SCHEMATIC DESIGN	

Job No.		Date
2018-1071		8/30/2020
Scale:		Drawn / Checked
AS SHOWN		MEU/AT
Sheet No.		Sheet Title
		DETAILS