

**19 SECTION 2 @ MAIN OFFICE DESK**  
3/4" = 1'-0"

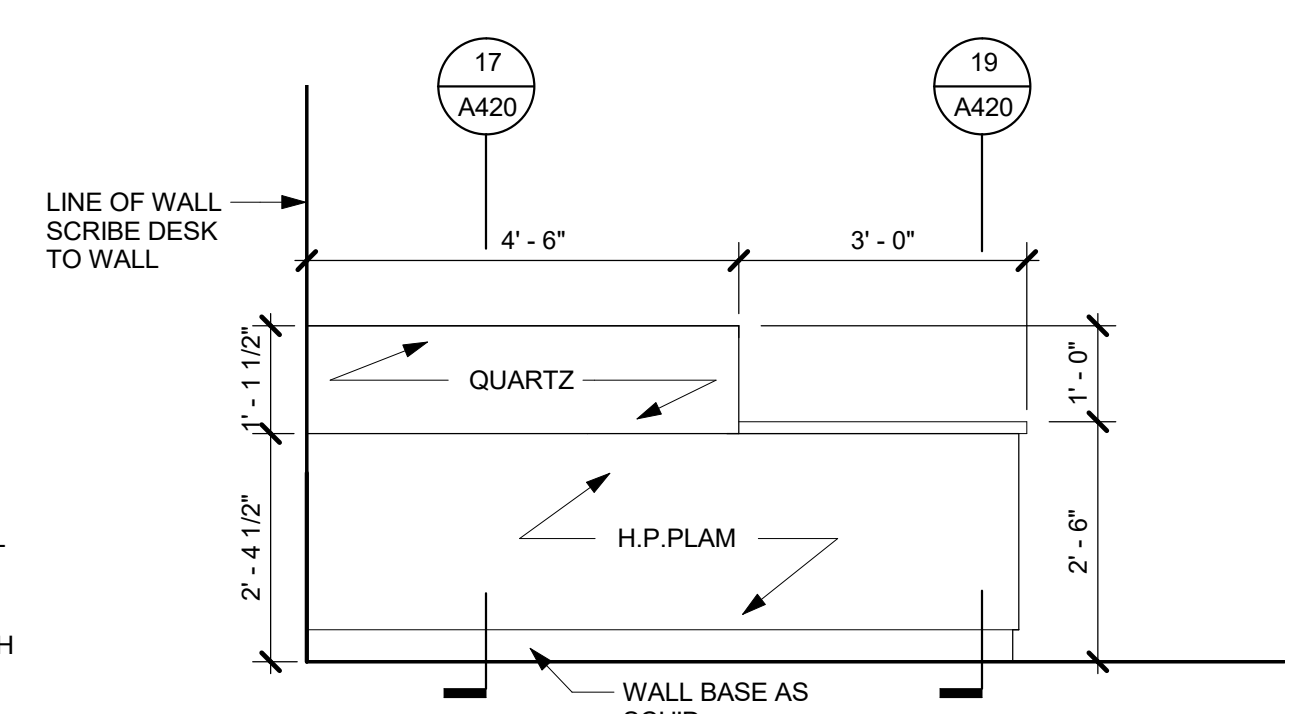

**18 MAIN OFF. FRONT DESK SOUTH ELEV**  
1/2" = 1'-0"

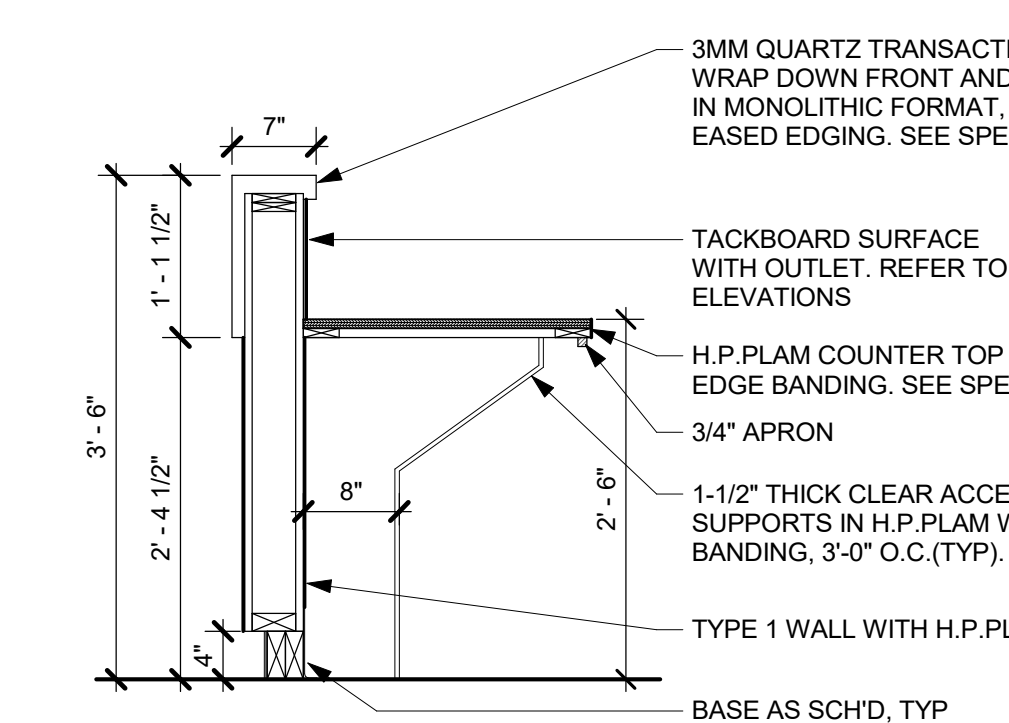

**17 SECTION 1 @ MAIN OFFICE DESK**  
3/4" = 1'-0"

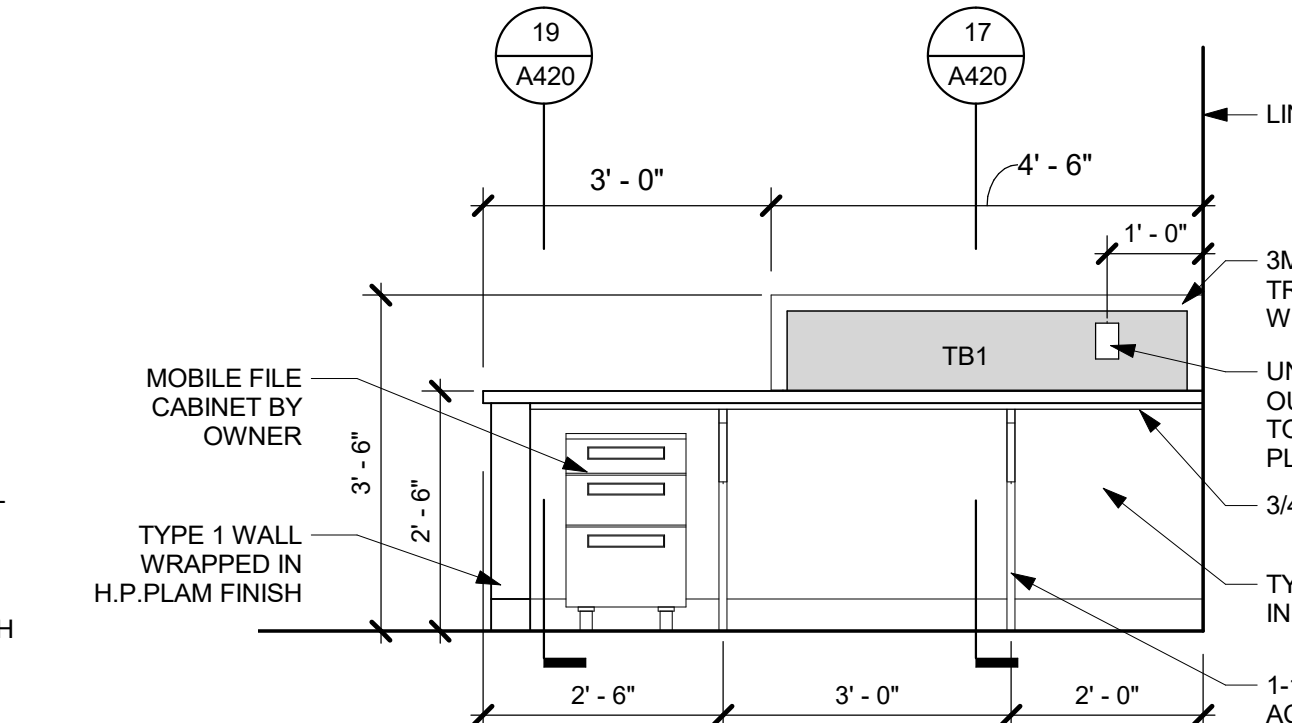

**16 MAIN OFF. - FRONT DESK NORTH ELEV**  
1/2" = 1'-0"

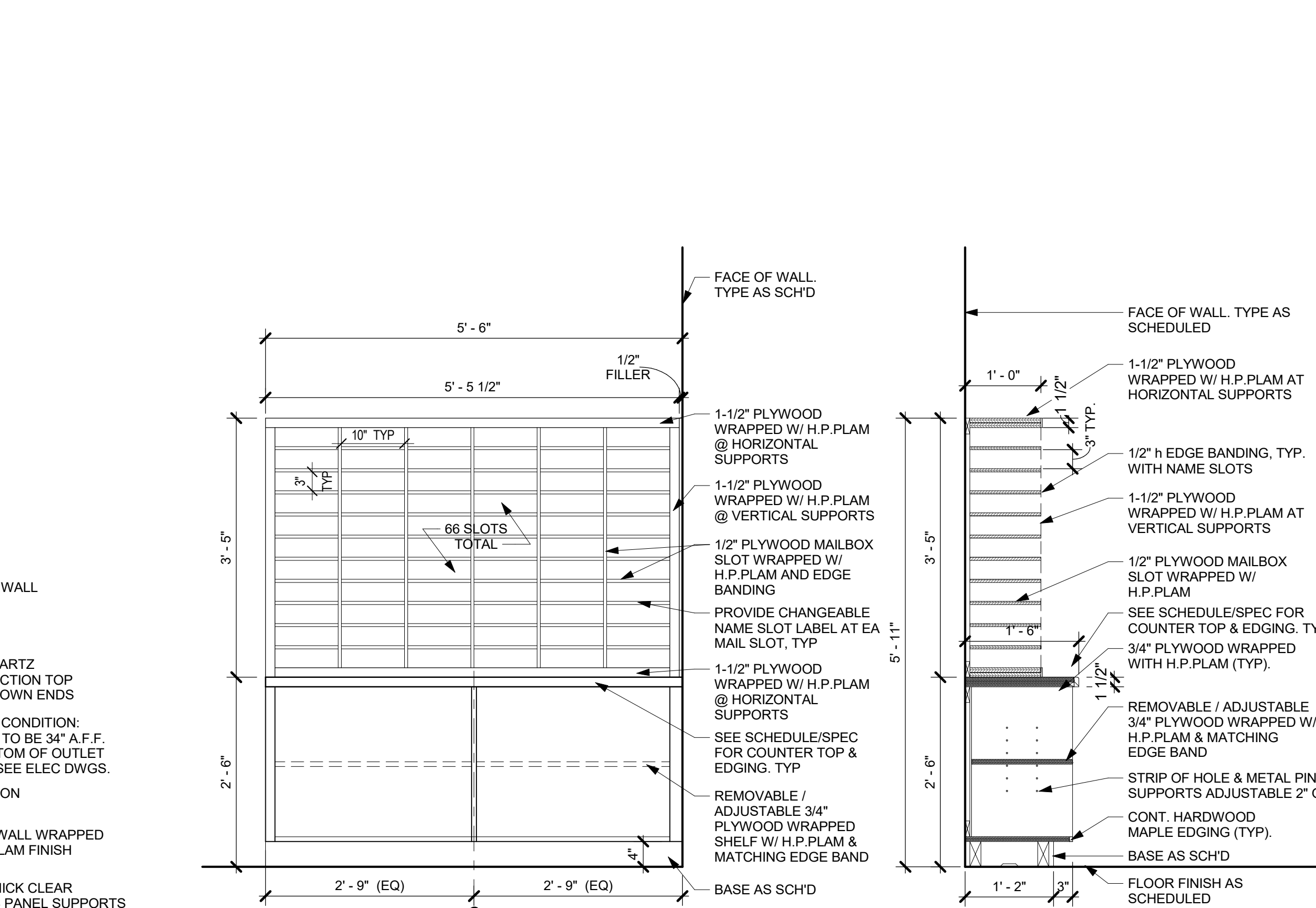

**15 TYPICAL MAILBOX COUNTER**  
3/4" = 1'-0"

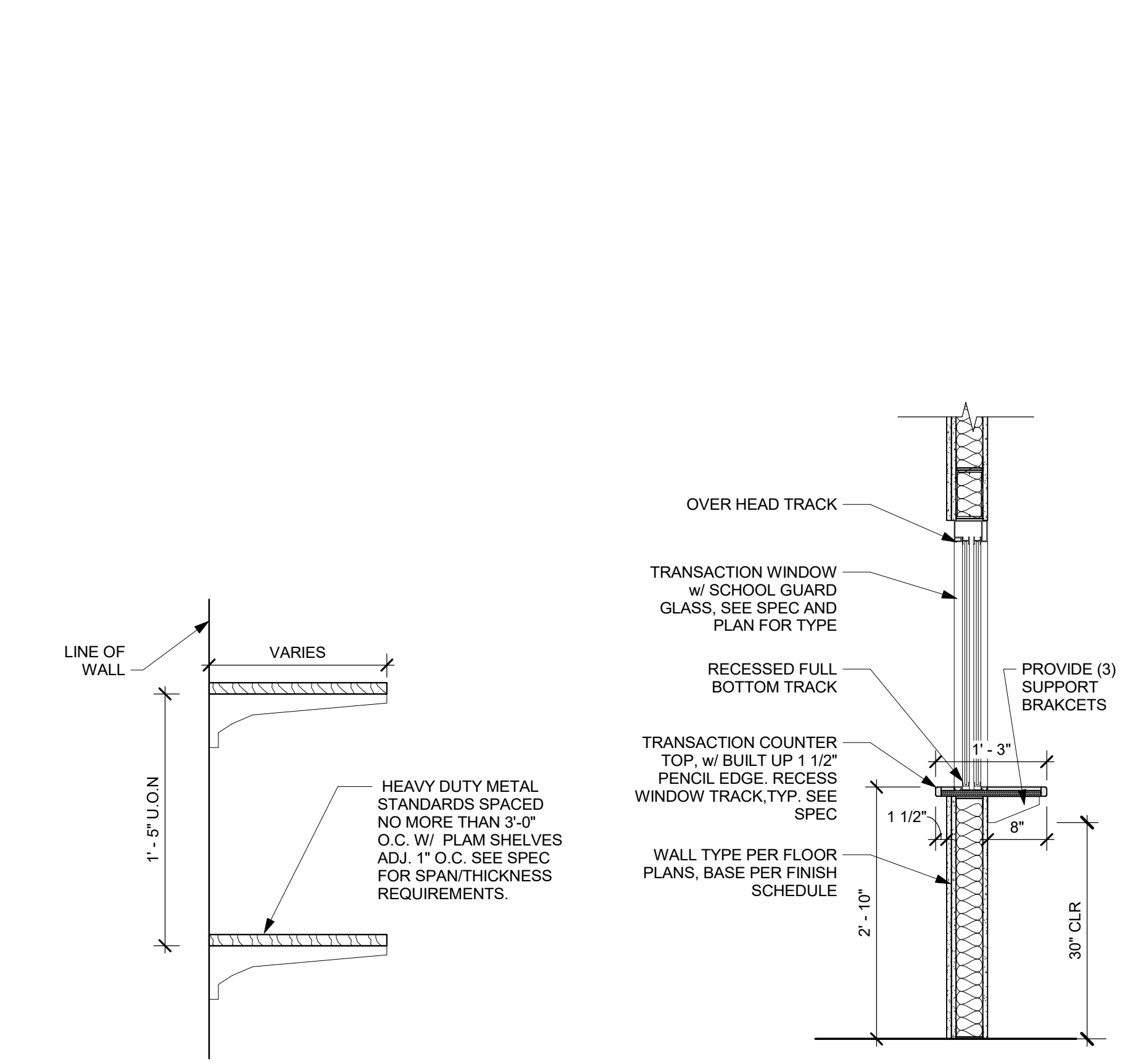

**14 SECTION THRU SHELVES**  
1 1/2" = 1'-0"

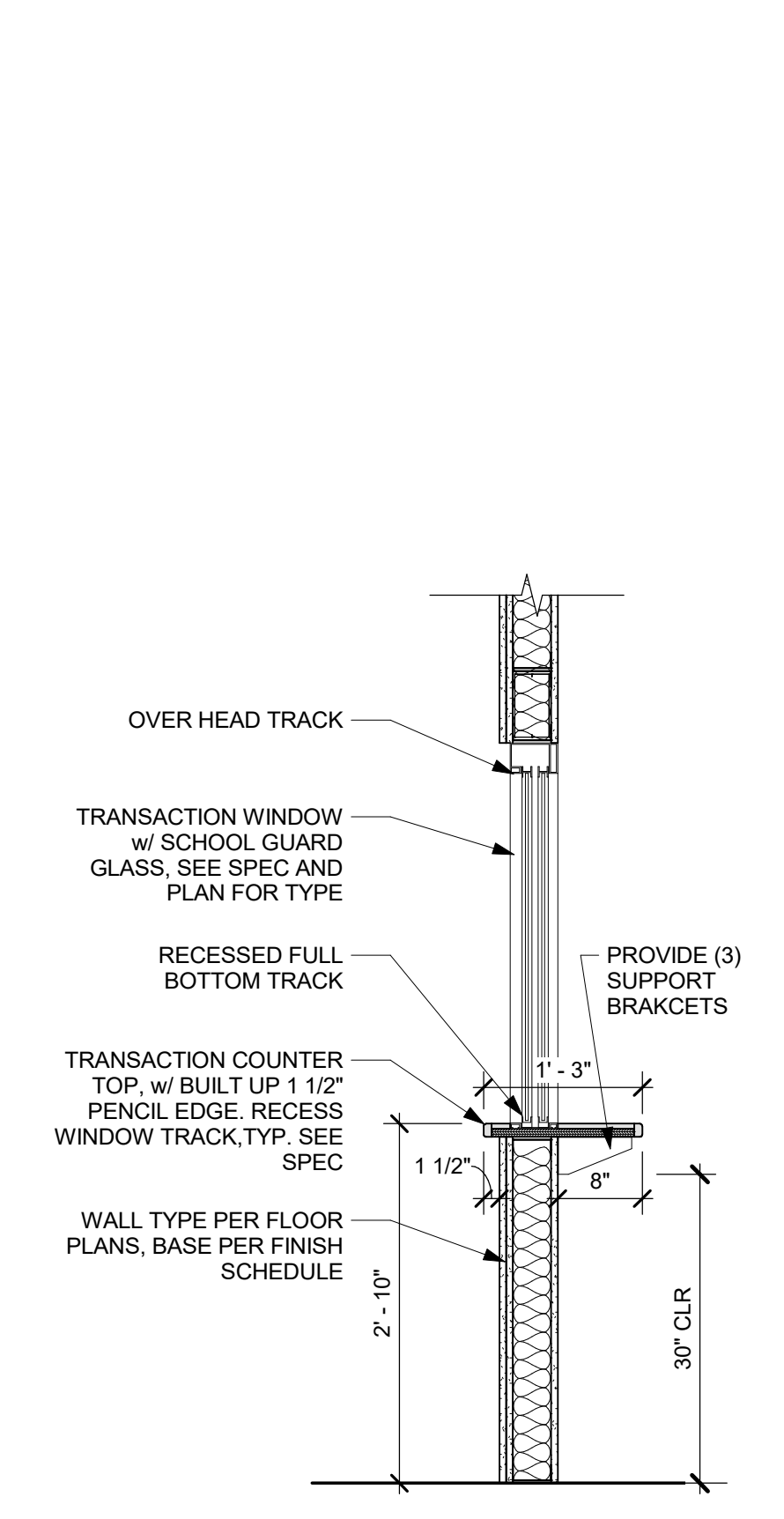

**13 TYP TRANSACTION WINDOW**  
3/4" = 1'-0"

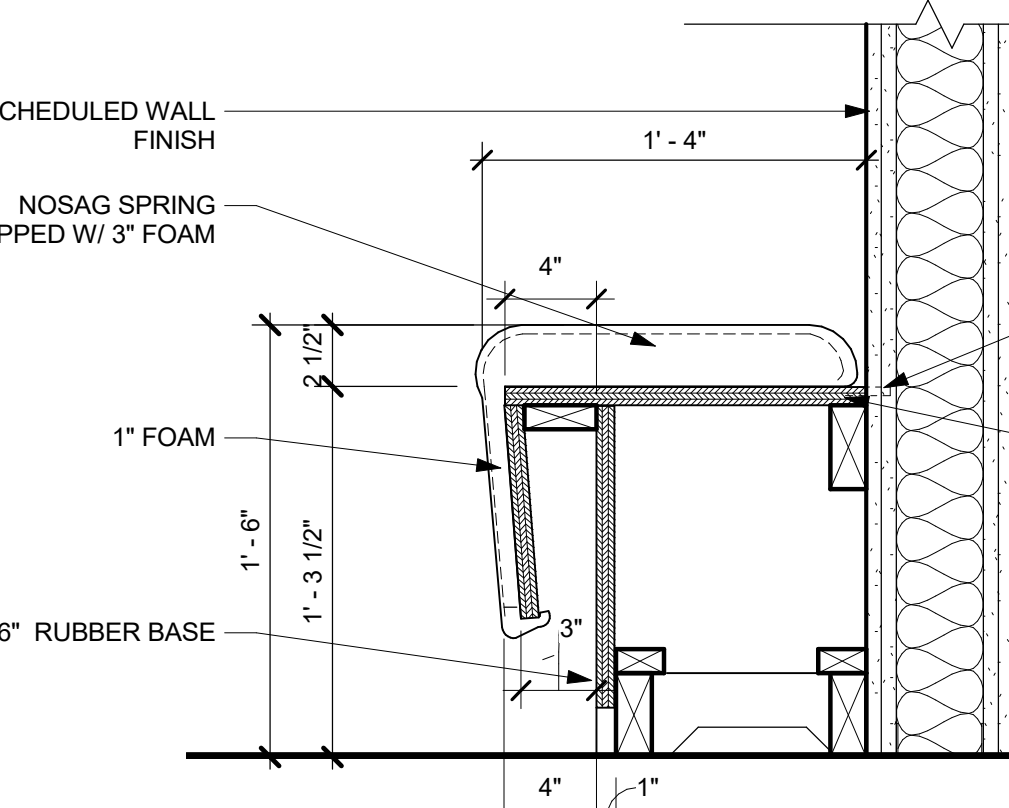

**12 SECTION THRU UPHOLSTERED BENCH**  
1 1/2" = 1'-0"

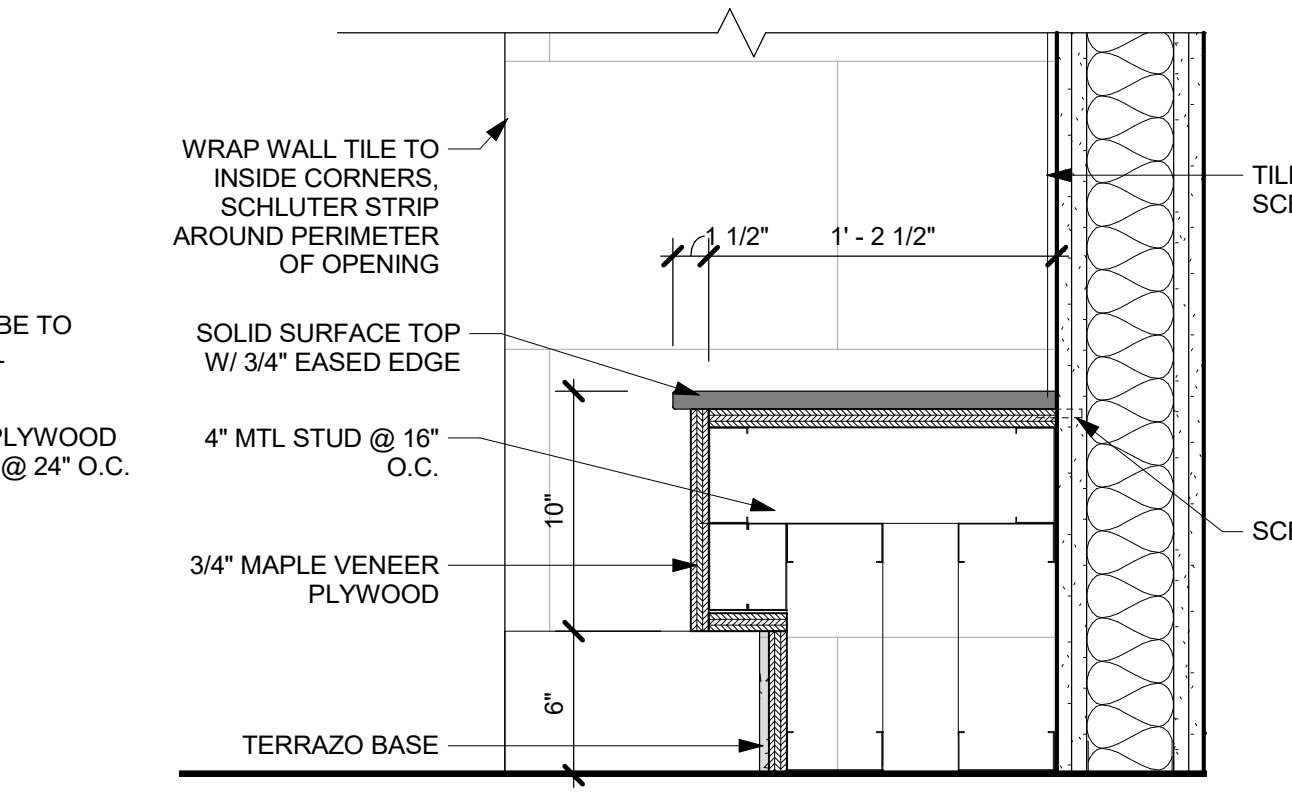

**11 SECTION THRU BUILT-IN BENCH**  
1 1/2" = 1'-0"

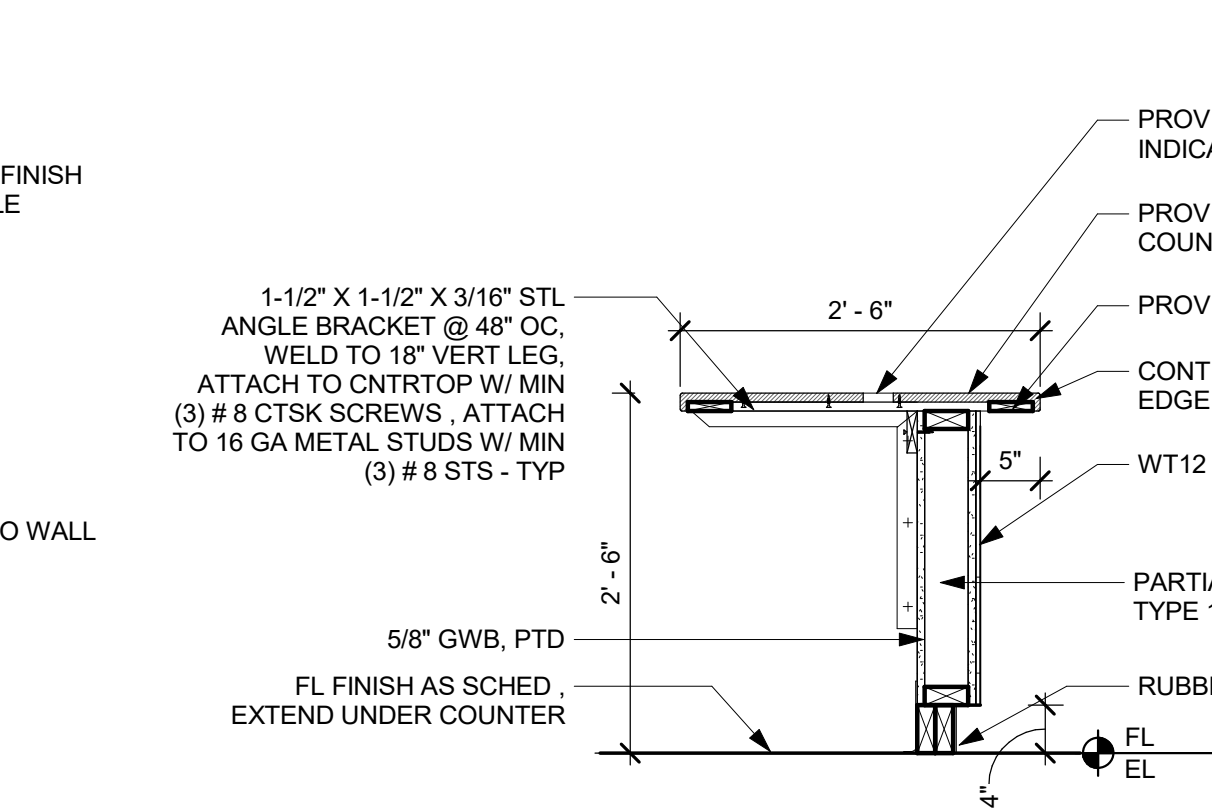

**10 SECTION @ CIRCULATION DESK 2**  
3/4" = 1'-0"

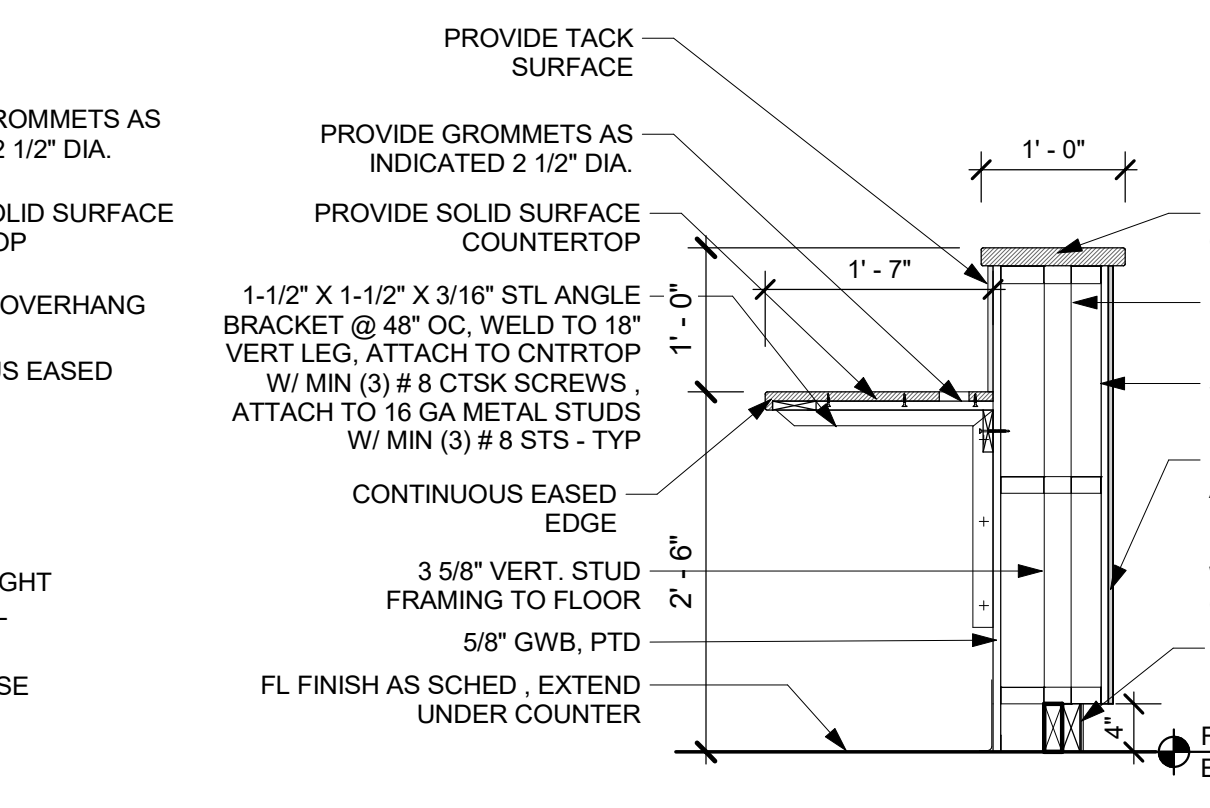

**9 SECTION @ CIRCULATION DESK**  
3/4" = 1'-0"

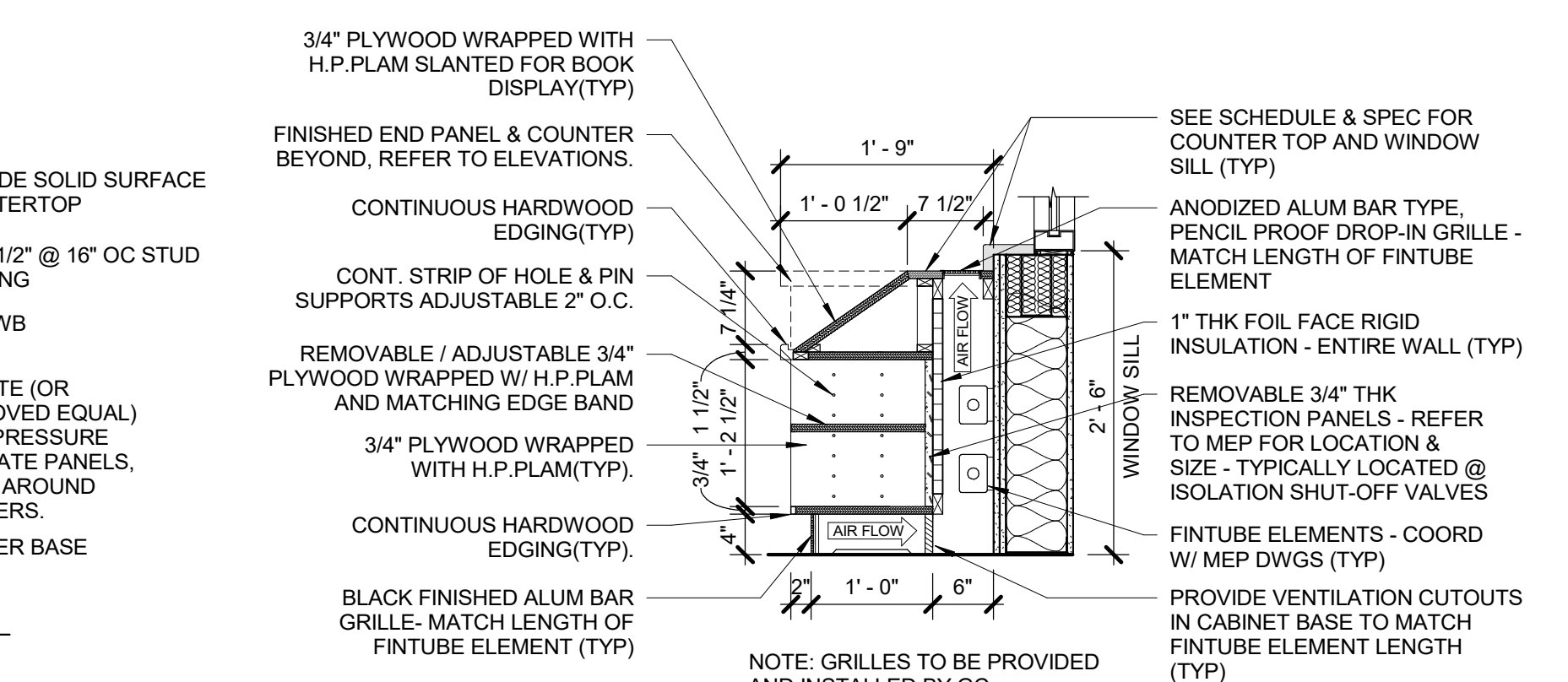

**8 SECTION @ BOOK DISPLAY CABINET @ EXT WINDOW SILL**  
3/4" = 1'-0"

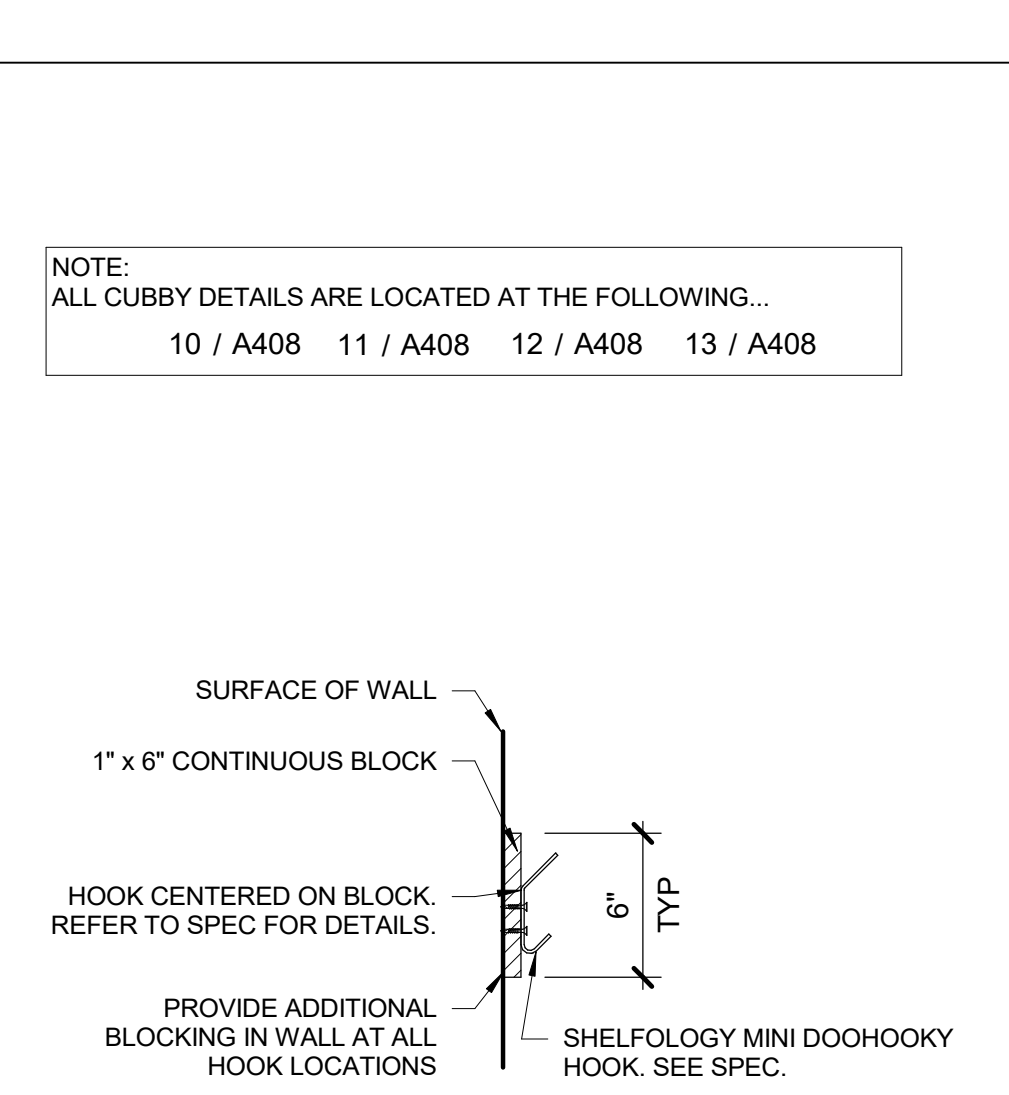

**7 SECTION @ ART CABINET EXT WINDOW SILL**  
3/4" = 1'-0"

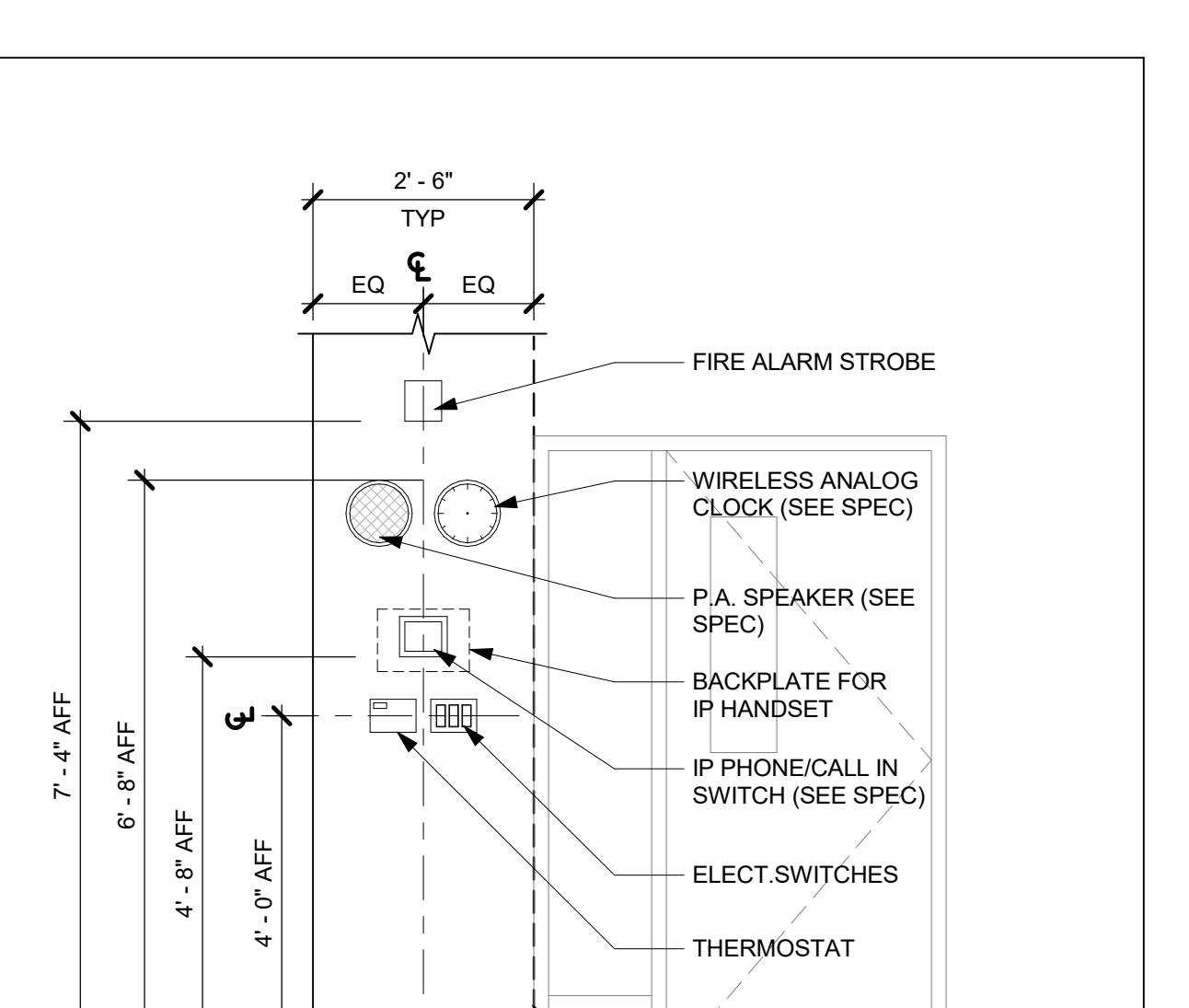

**6 SECTION @ BASE CABINET EXT WINDOW SILL**  
3/4" = 1'-0"

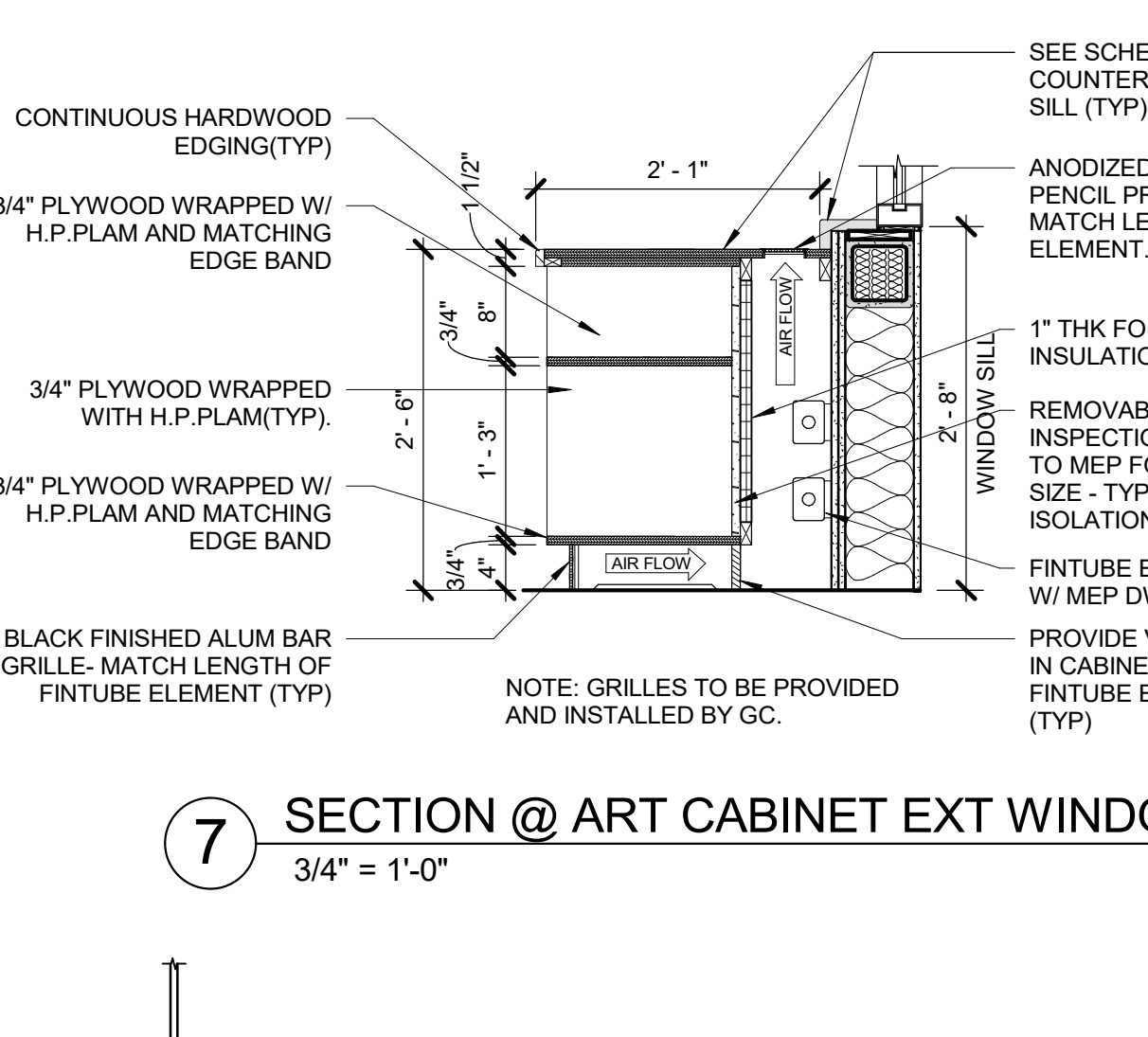

**5 SECTION @ BASE CABINET**  
3/4" = 1'-0"

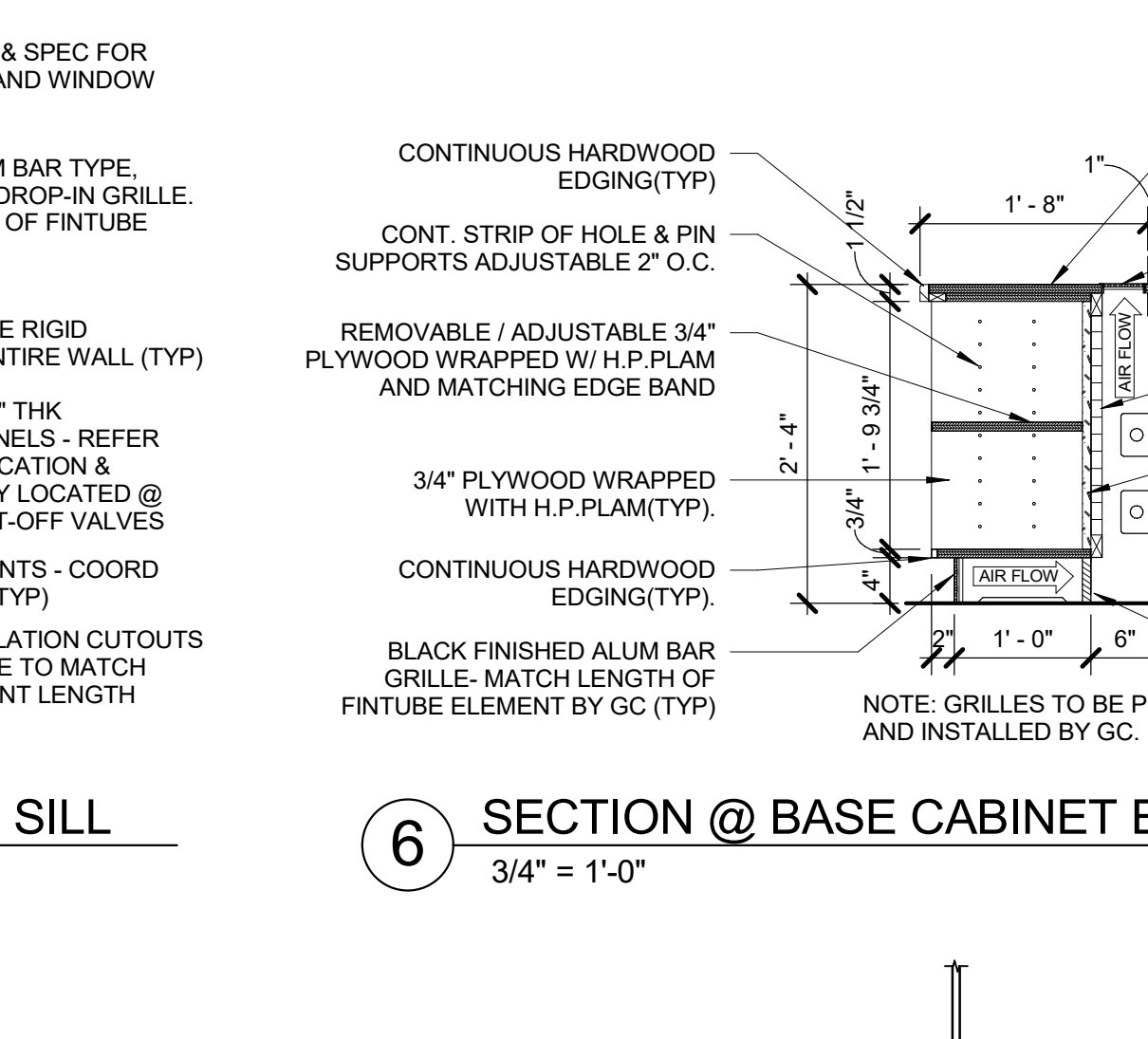

**4 SECTION @ CHILD SINK W/ CABINET**  
3/4" = 1'-0"

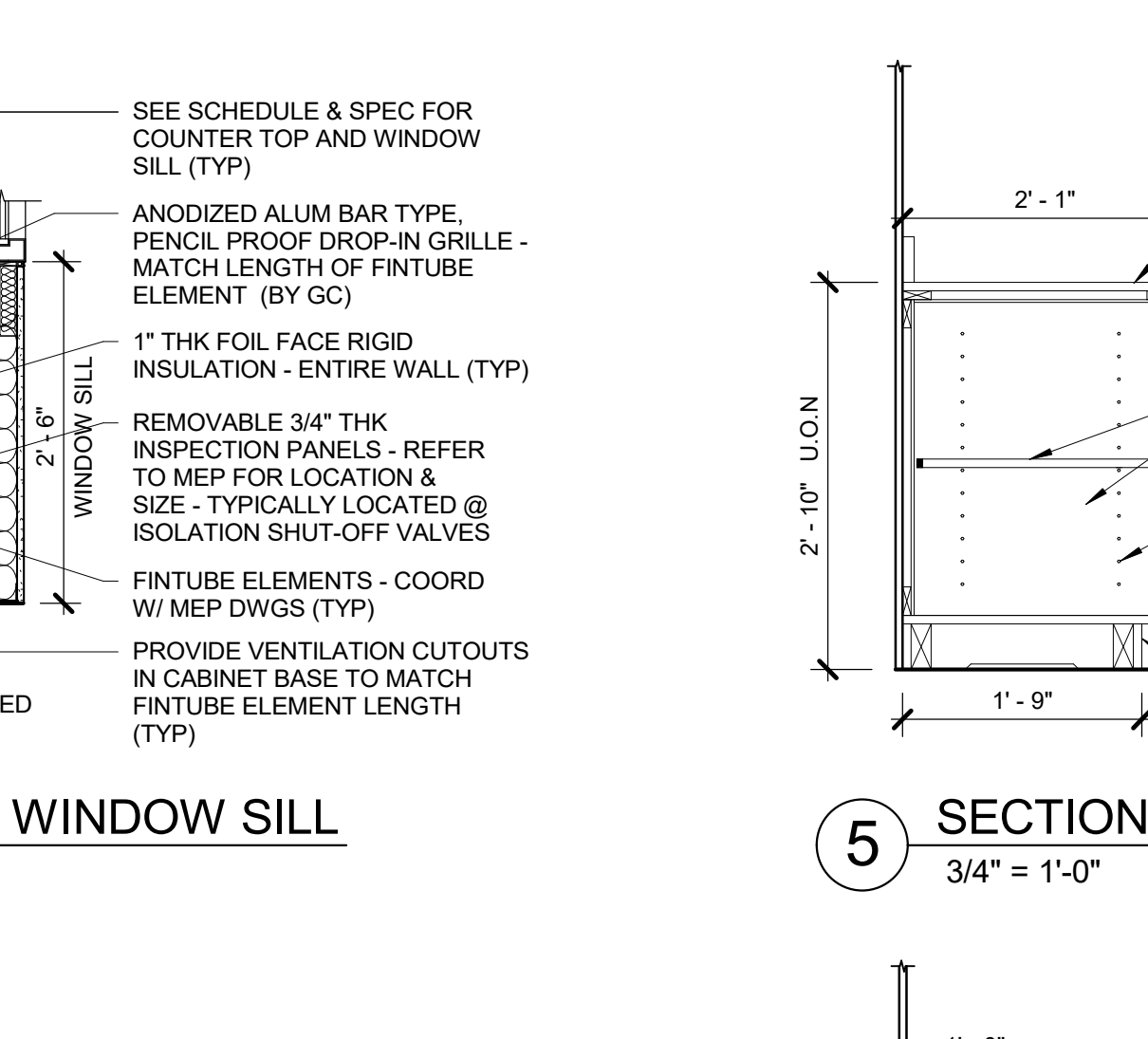

**3 SECTION @ ADA SINK**  
3/4" = 1'-0"

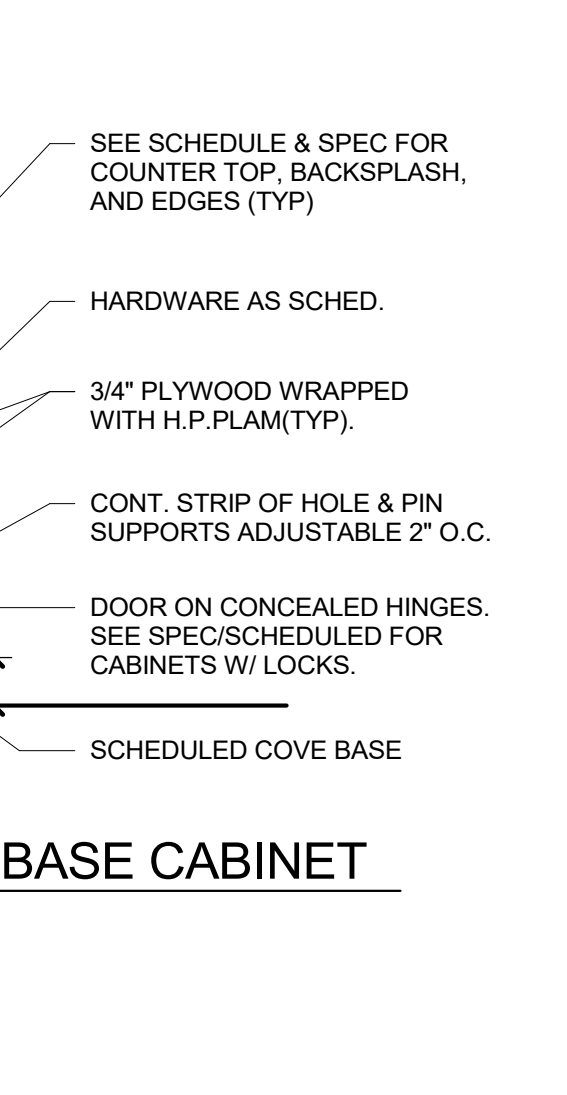

**2 SECTION @ CABINET W/ DRAWERS**  
3/4" = 1'-0"

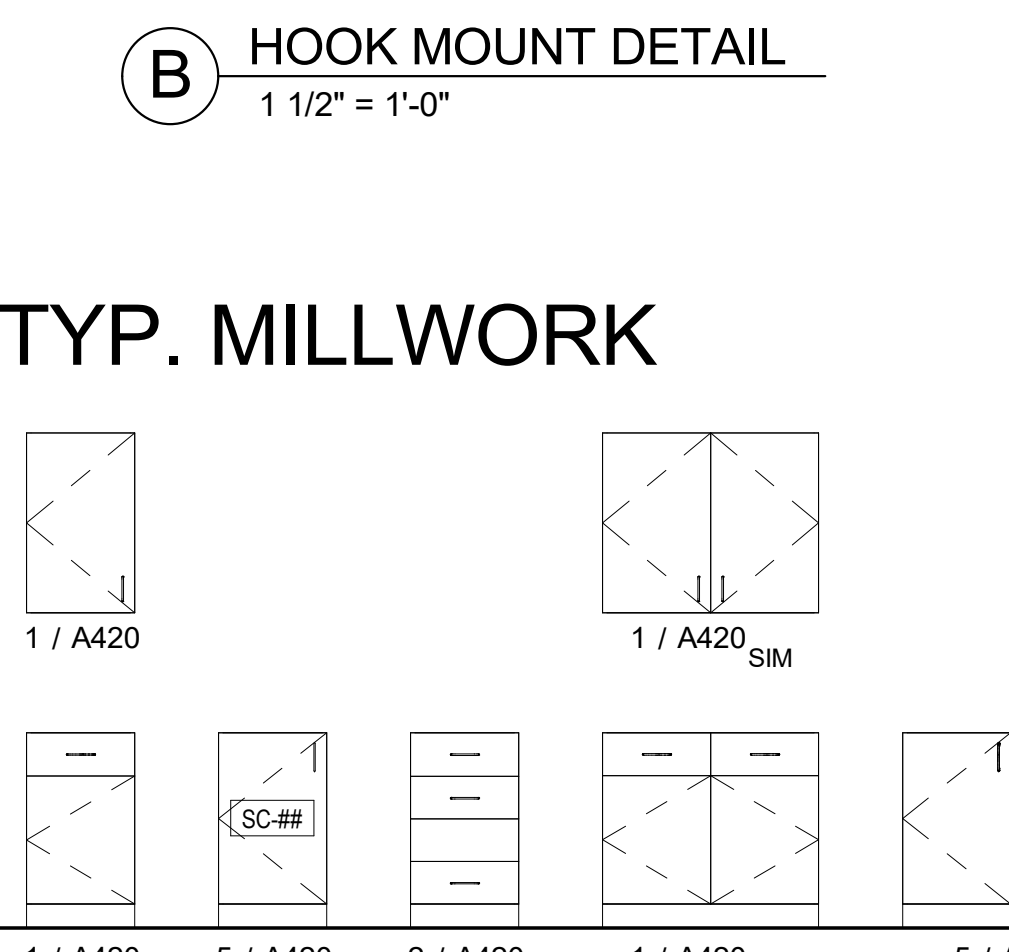

**1 TYP. SECTION @ BASE & WALL CABINET**  
3/4" = 1'-0"

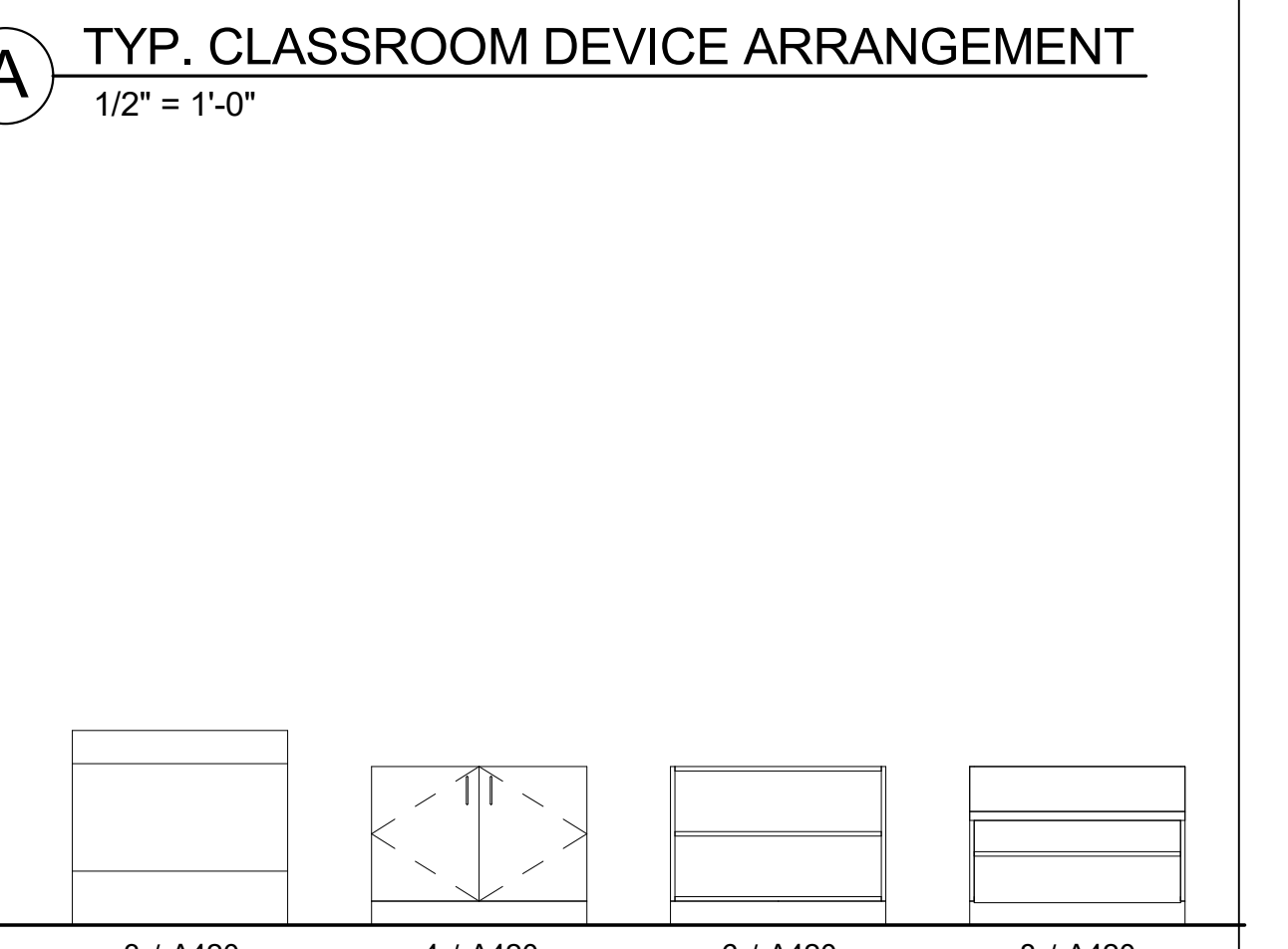

**4 SECTION @ CHILD SINK W/ CABINET**  
3/4" = 1'-0"

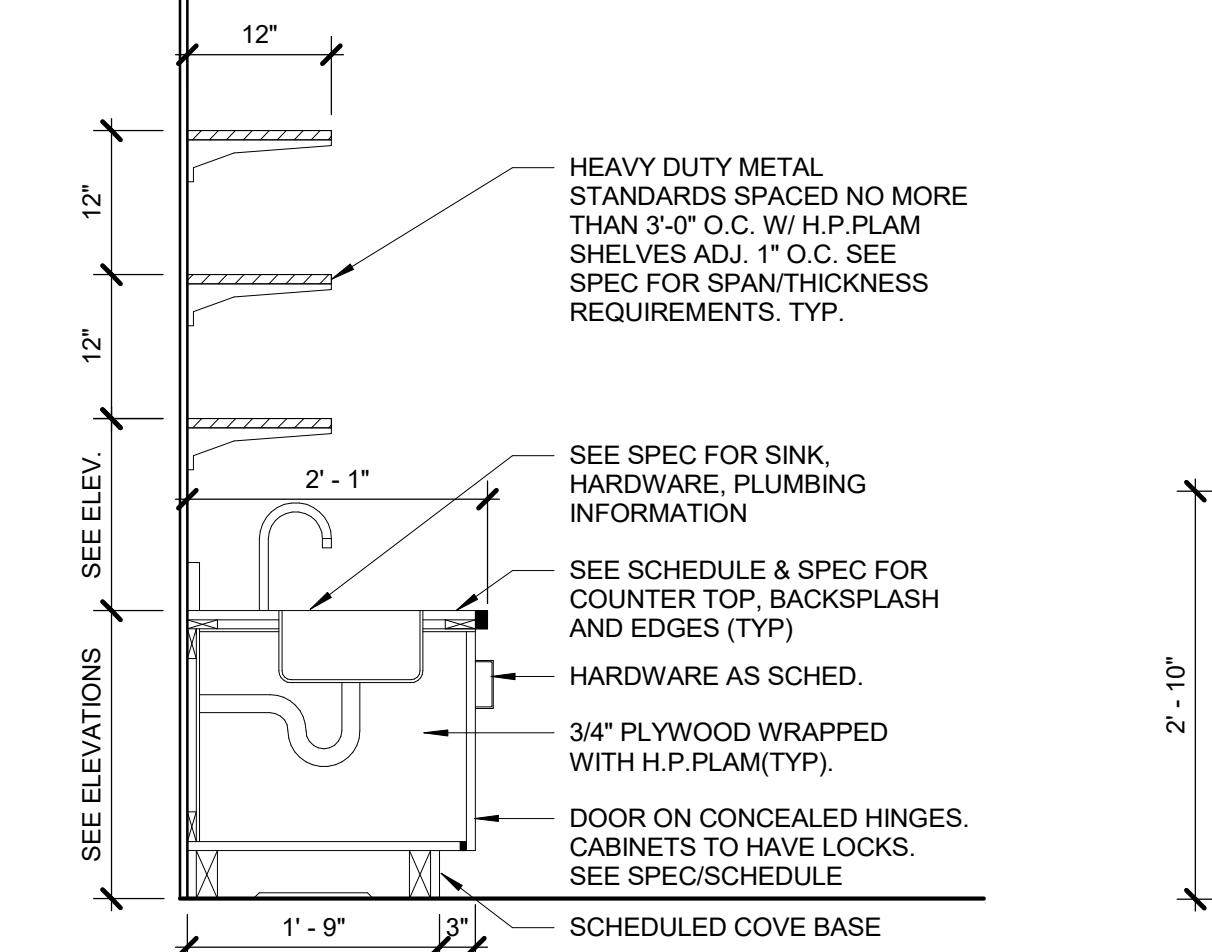

**3 SECTION @ ADA SINK**  
3/4" = 1'-0"

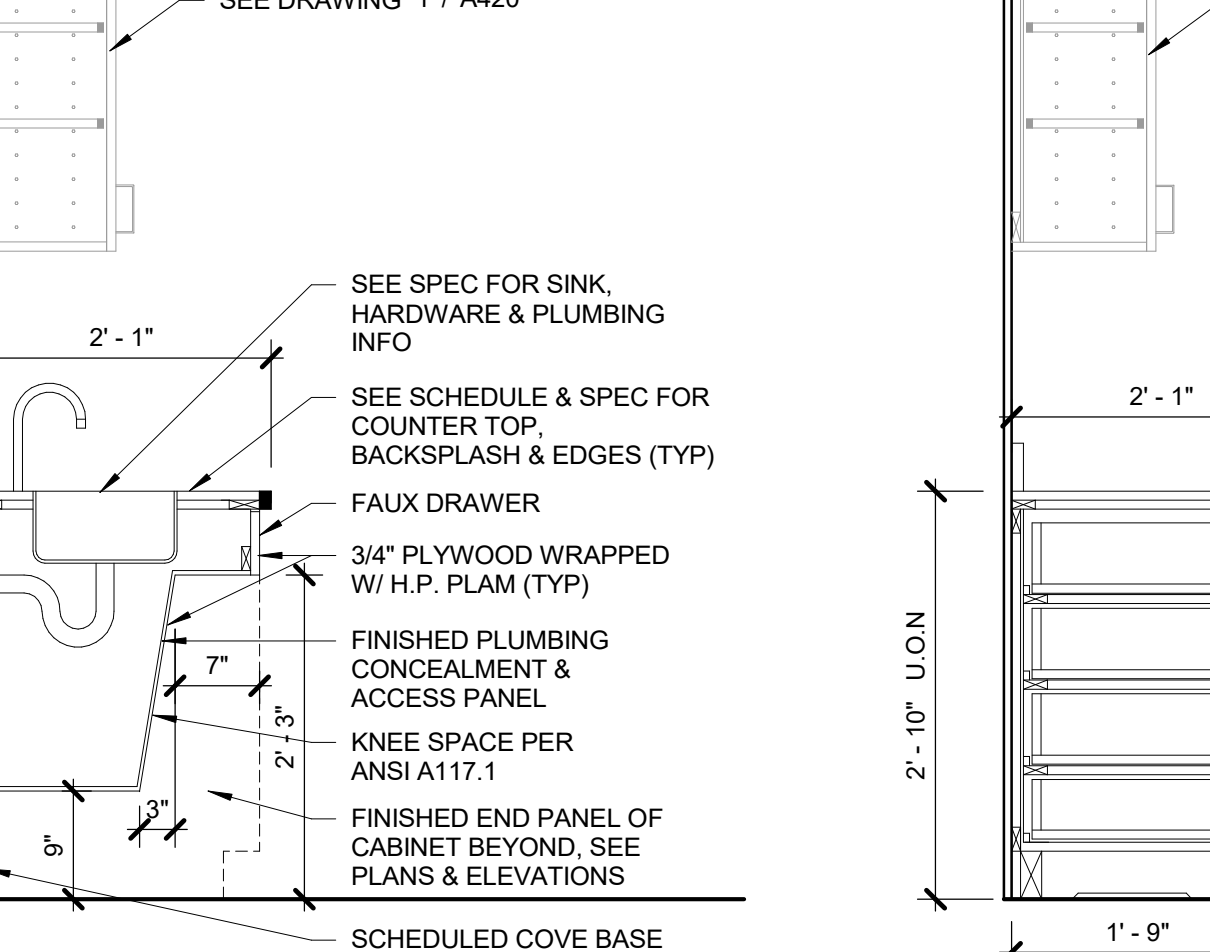

**2 SECTION @ CABINET W/ DRAWERS**  
3/4" = 1'-0"

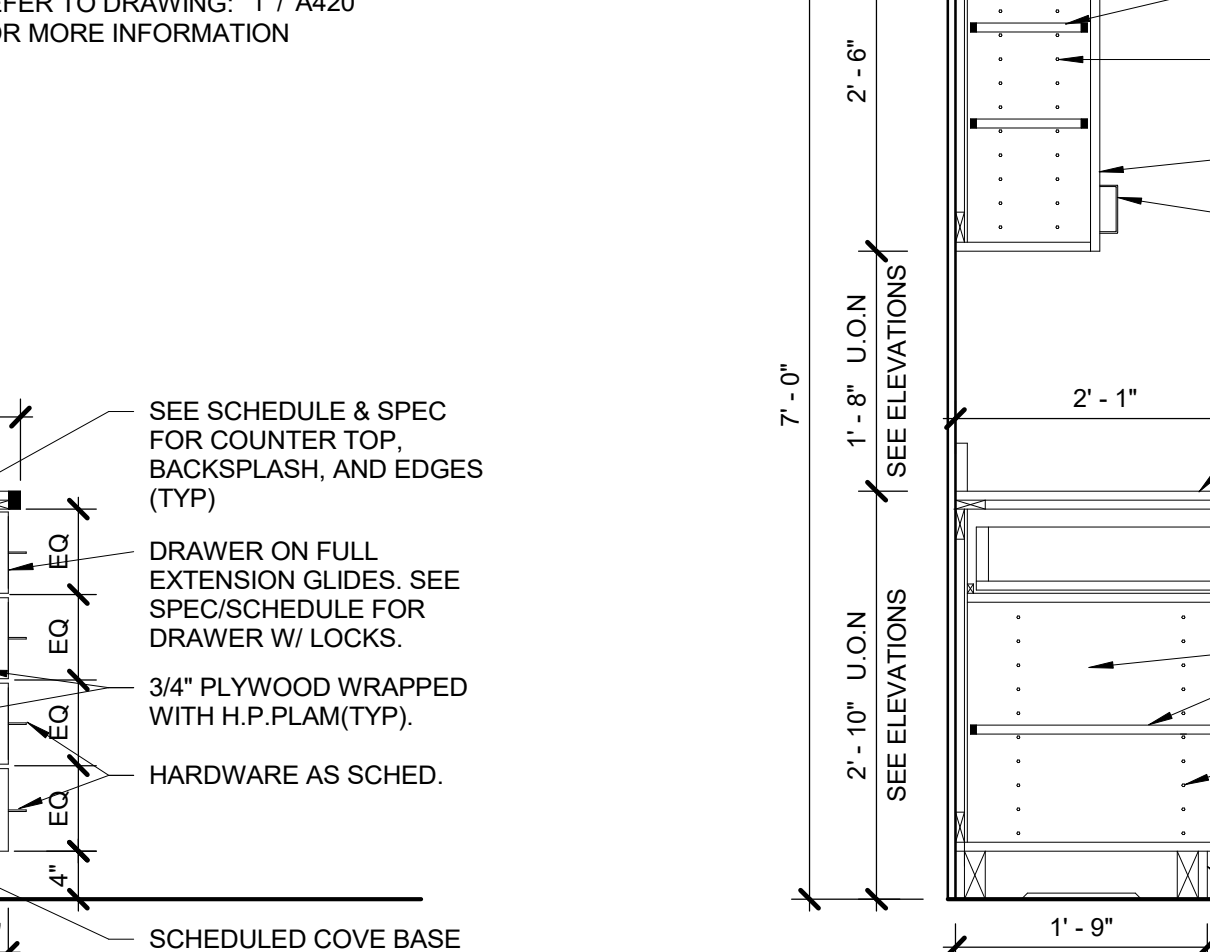

**1 TYP. SECTION @ BASE & WALL CABINET**  
3/4" = 1'-0"

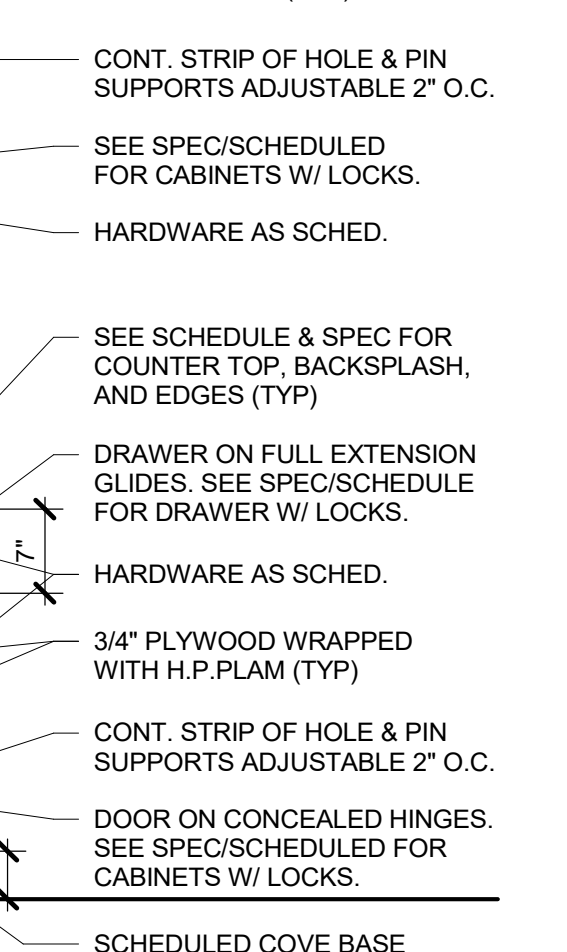

**4 SECTION @ CHILD SINK W/ CABINET**  
3/4" = 1'-0"

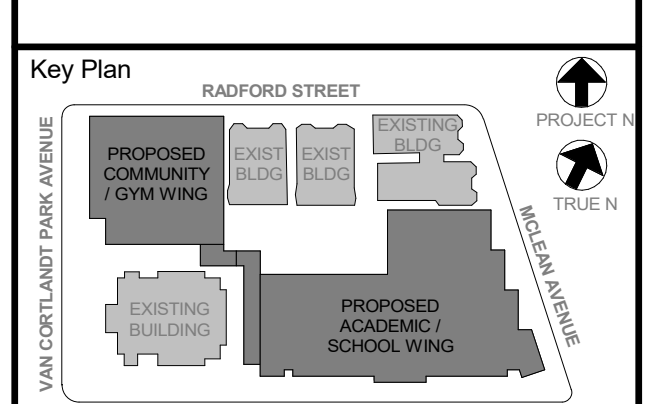

**NOTE:** ALL LOCAL DESIGN REQUIREMENTS ARE TO BE ADHERED TO AND INDICATED ON THIS DOCUMENT. UNLESS ACTING UNDER THE DIRECTION OF THE LICENSED ARCHITECT, ENGINEER, PROFESSIONAL DESIGNER, OR ARCHITECT, NO ONE SHOULD BE PERMITTED TO MAKE ANY CHANGES OR ALTERATIONS TO THIS DRAWING WITHOUT THE WRITTEN PERMISSION OF KG+D.

DATE: 07/14/2021  
SCALE: AS NOTED  
DRAWN / CHECKED: [Signature]

Professional Seal

No.	Date	Issue
5	11/01/2021	ISSUE FOR BID
3	07/14/2021	CONSTRUCTION DOCS - NYS ED

**TYP. MILLWORK DETAILS & OTHER INTERIOR DRAWINGS**

Job No. 2019-1026 Date 07/14/2021  
Scale AS NOTED Drawn / Checked [Signature]

Sheet Number

**A420**