

# BULLETIN # 30

**DATE:** March 23, 2026

**TO:** Piazza Inc.  
Attn: John Piazza

**CC:** Chaker Maghak, Hill Intl.

**FROM:** Brian Dunn, AIA  
KG+D Architects, PC

**PROJECT:** Harrison Recreation & Community Center – PHASE 2  
Harrison, NY

**RE:** Add Guardrails at High Roof



At the request of the Owner please provide pricing to add a ballasted roof guardrail system at the high roof and the Gym roof. The ballasted guardrail to be by Safepro, or equal by Kee or Garlock. Exact layout to be determined based on module lengths (4'-0" min). See attached Roof Plan for layout. Provide walk pads under each base. Provide custom color to be selected from manufacturer's powder coating selections.

Encl: *Roof Plan 204*

**KG+D Architects, PC**

285 Main Street, Mount Kisco, New York 10549

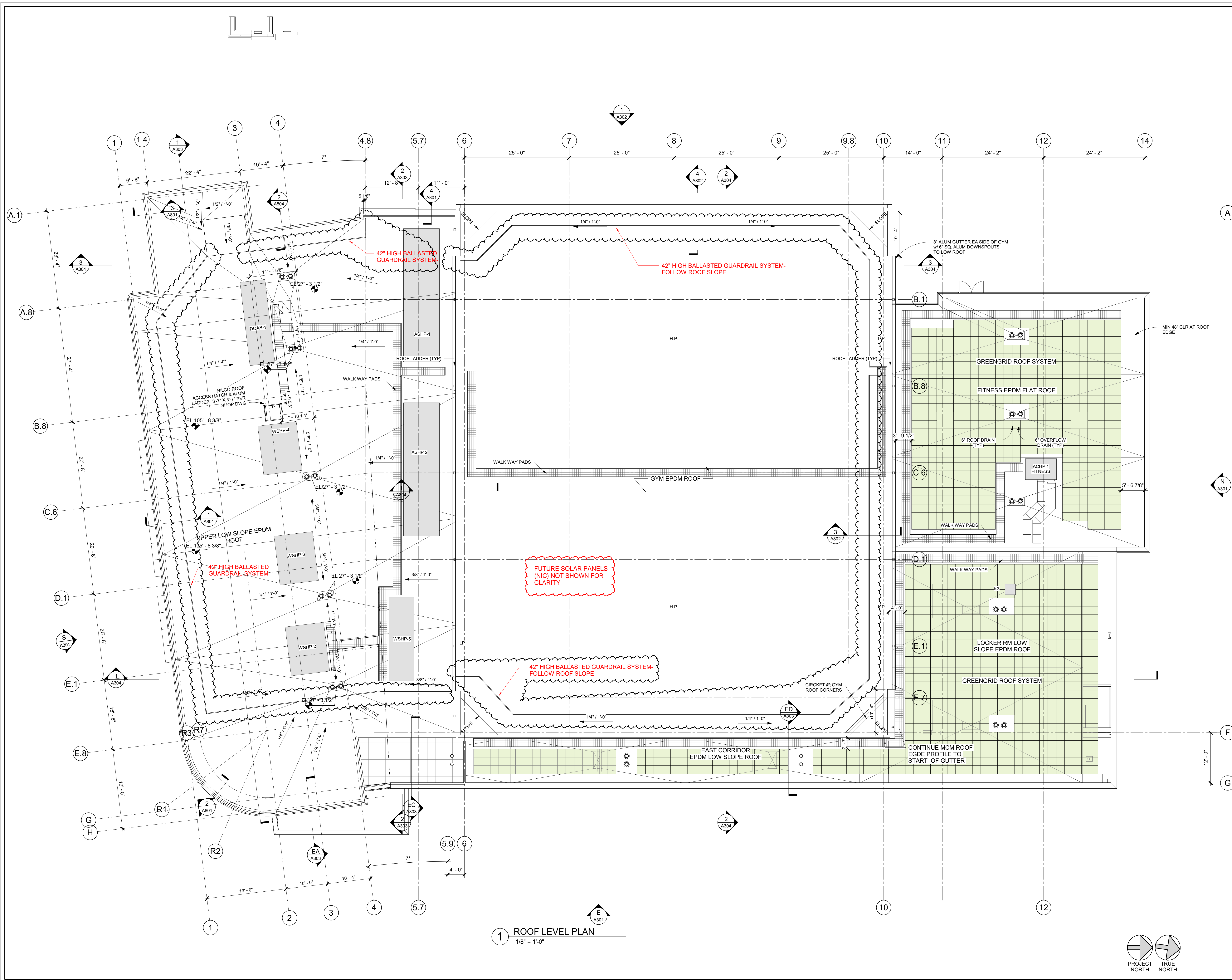
914.666.5900 [kgdarchitects.com](http://kgdarchitects.com)

**HARRISON  
RECREATION &  
COMMUNITY  
CENTER**

New Construction - Phase 2  
Town / Village of Harrison  
270 Harrison Avenue  
Harrison, NY 10528



**CONSTRUCTION DOCUMENTS**



**1 ROOF LEVEL PLAN**  
1/8" = 1'-0"

NOTE: ALL DIMENSIONS, ARRANGEMENTS AND FINISHES INDICATED OR REPRESENTED BY THIS DRAWING ARE OWNED BY AND ARE THE PROPERTY OF KG+D ARCHITECTS, PC. NO PART OF THIS DRAWING OR ANY INFORMATION CONTAINED HEREIN SHALL BE REPRODUCED OR TRANSMITTED IN ANY FORM OR BY ANY MEANS, ELECTRONIC OR MECHANICAL, INCLUDING PHOTOCOPYING, RECORDING, OR BY ANY INFORMATION STORAGE AND RETRIEVAL SYSTEM, WITHOUT THE WRITTEN PERMISSION OF KG+D.

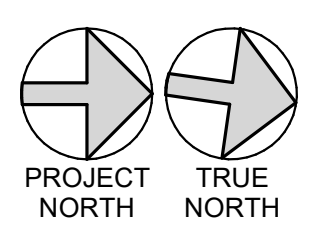
IF THERE ARE ANY DISCREPANCIES BETWEEN THIS DRAWING AND ANY PREVIOUS DRAWING, THE LATEST DRAWING SHALL PREVAIL. CONTRACTOR SHALL VERIFY ALL DIMENSIONS AND CONDITIONS ON THE JOB AND THE ARCHITECT SHALL BE NOTIFIED OF ANY DISCREPANCIES IMMEDIATELY. ALL DIMENSIONS SHALL BE TO FACE UNLESS OTHERWISE NOTED. SHOP DETAILS MUST BE SUBMITTED TO THE OFFICE FOR APPROVAL BEFORE PROCEEDING WITH FABRICATION.

ALL INFORMATION BY ANY PERSON IN ANY WAY OF ANY OTHER CONTAINED ON THIS DOCUMENT, AND/OR ANY INFORMATION CONTAINED ON THE ORIGINAL OR ANY COPY OF THIS DOCUMENT, IS THE PROPERTY OF KG+D ARCHITECTS, PC. A VIOLATION OF THIS POLICY IS A VIOLATION OF FEDERAL AND STATE LAWS. ALL RIGHTS RESERVED.

No.	Date	Issue
7	10/09/2024	CONFORMED SET
6	07/16/2024	BID ADDENDUM #4
4	06/05/2024	ISSUED FOR BID
3	01/16/2024	ISSUED FOR PERMIT
2	06/01/2020	DESIGN DEVELOPMENT
1	03/11/2020	50% DESIGN DEVELOPMENT

**ROOF LEVEL PLAN**

Job No:	2020-1005	Date:	03/31/2020
Scale:	AS NOTED	Drawn / Checked:	...
Sheet Number:	A204		



# SAFEPRO BALLASTED GUARDRAIL INSTALLATION MANUAL



**ASSEMBLE AND USE AS SPECIFIED IN THE INSTRUCTIONS MANUAL TO MEET OSHA COMPLIANCE REGULATIONS, AS STATED, UNDER STANDARDS-29 CFR, 1910.29 & STANDARDS-29 CFR, 1926.502.11.**

**INSTALLATION TOOLS REQUIRED: 1/4" HEX KEY**

**TOOLS RECOMMENDED: 1/4" HEXSOCKET BIT, SOCKET ADAPTOR, CORDLESS IMPACT DRIVER**

**WARNING: FAILURE TO COMPLY WITH MANUFACTURER'S INSTALLATION AND USE PROCEDURE MAY RESULT IN PROPERTY DAMAGE, PERSONAL INJURY OR DEATH. ONLY COMPETENT PERSONS EXPERIENCED IN THESE INSTALLATION METHODS SHALL INSTALL SAFEPRO EQUIPMENT. IF METHOD OF USE IS NOT UNDERSTOOD, DO NOT ATTEMPT TO USE THE EQUIPMENT.**

Updated MARCH 2023

## TABLE OF CONTENTS

<b>SYSTEM COMPLIANCE AND PRE-INSTALLATION MESSAGE</b>	<b>3</b>
<b>DEFINITIONS</b>	<b>4</b>
<b>GUARDRAIL PARTS LIST</b>	<b>5</b>
<b>SAFEPRO SECTION VIEWS - MODULAR SYSTEM</b>	<b>6</b>
<b>SAFEPRO GUARDRAIL SPECIFICATION - PANEL SYSTEM</b>	<b>7</b>
<b>SAFEPRO GUARDRAIL SPECIFICATION - TOPVIEW</b>	<b>8</b>
<b>SAFEPRO GUARDRAIL SPECIFICATION - SPLICE</b>	<b>9</b>
<b>INSTALLATION REQUIREMENTS</b>	<b>10</b>
<b>SAFEPRO BALLASTED GUARDRAIL INSTALLATION PROCEDURES</b>	<b>11</b>
<b>TOEBOARD BEST PRACTICES &amp; COMPLIANCE</b>	<b>12</b>
<b>SYSTEM INSPECTION &amp; DISCLAIMER</b>	<b>13</b>

## SYSTEM COMPLIANCE

- System is designed to comply with OSHA Standards 29 CF 1910.29 & 29 CFR 1926.502.11. NOTE: The standard ballasted guardrail design may be reconfigured by SafePro to comply with CalOSHA Title 8, 3209.
- System is certified for use in Factories, Industrial, Storage Occupancies, and in areas that are not accessible to the general public and that serve an occupant load no greater than 50 as per ASCE 7-10 4.5.1(2).
- System is designed to withstand a load of 200 lb (90.7 KG), minimum, in any direction to all components without failing in accordance with OSHA regulation 29 CFR 1926.502 and 29 CFR 1910.29. This loading represents an individual accidentally impacting the rail. Do not intentionally load the guardrail.
- The ballasted guardrail system is designed to withstand an ASCE 7-16 Ultimate Wind Load of up to 130 MPH on a Risk Category II building with Exposure Category B. The standard design configuration may be reconfigured by SafePro to accommodate alternate site conditions if required.
- Toeboards are capable of withstanding, without failure, a force of at least 50 pounds applied in any downward or outward direction at any point along the toeboard.

## PRE-INSTALLATION MESSAGE

- Applications of SafePro ballasted Guardrail should be verified and approved by a competent safety personnel. Fall Protection Systems shall be designed to comply with OSHA or applicable state regulatory limitations.
- Verify that the surface the SafePro ballasted Guardrail will be installed onto is capable of supporting the product and personnel installing it. A complete assessment of the entire surrounding areas should be made to determine if the walking and working surfaces have the strength and structural integrity to support users safely.
- Only install guardrail on flat dry clean surfaces under conditions where adequate illumination is provided.
- If it is necessary to remove guardrails during a portion of a particular job, make sure to re-secure the unit before resuming work.
- If the guardrail is impacted, inspection and adjustment or replacement is required by a competent person prior to further use. If damaged parts are found, replace with new ones.
- Never erect guardrail near electrical wires. Keep a minimum of ten (10) feet from power lines.
- Never install or use guardrails on top of gravel, metal or on slippery surfaces without speaking with a SafePro representative.
- Routine inspection of all parts is recommended. If damaged parts are found, replace with new parts. Contact SafePro immediately.

## DEFINITIONS

- **COUNTERWEIGHTED BASE:** Supporting non-penetrating base for guardrail system.
- **COMPETENT PERSON:** Defined by 29 CFR 1926.32 (f) as someone *...who is capable of identifying existing and predictable hazards in the surroundings or working conditions which are unsanitary, hazardous, or dangerous to employees, and who has authorization to take prompt corrective measures to eliminate them...*
- **CONTINUOUS RUN:** A single or series of guardrail panels or modules installed in a continuous, without interruption, straight line.
- **LEADING EDGE:** The edge of a floor, roof, or formwork for a floor or other walking/working surface (such as the deck) which changes location as additional floor, roof or deck, or formwork sections are placed or constructed. A leading edge is considered an unprotected side and edge.
- **OUTRIGGER:** A 6-foot, 8-foot or 10-foot long SafePro guardrail panel or module installed at a 90-degree angle to a continuous run with a COUNTERWEIGHTED BASE connected to it. Designated on a site-specific basis where the ballasted guardrail system is subject to high wind conditions or load conditions in excess of Federal OSHA requirements.
- **QUALIFIED PERSON:** Defined by 29 CFR 1926.32 (m) as someone *“...who, by possession of a recognized degree, certificate, professional standing, or who by extensive knowledge, training, and experience, has successfully demonstrated his ability to solve or resolve problems relating to the subject matter, work, or the project...”*
- **RETURN:** A 5-foot minimum length SafePro guardrail panel or module installed at a 90 degree angle at the end of a continuous run with a COUNTERWEIGHTED BASE connected to it. Designated to stabilize the ends of each guardrail system for proper load capacity.
- **TOEBOARD:** A low protective barrier that will prevent the fall of materials and equipment to lower levels.
- **UNPROTECTED SIDE AND EDGE:** Any side or edge of a walking/working surface, e.g. floor, roof, ramp, or runway where there is no wall or guardrail system.

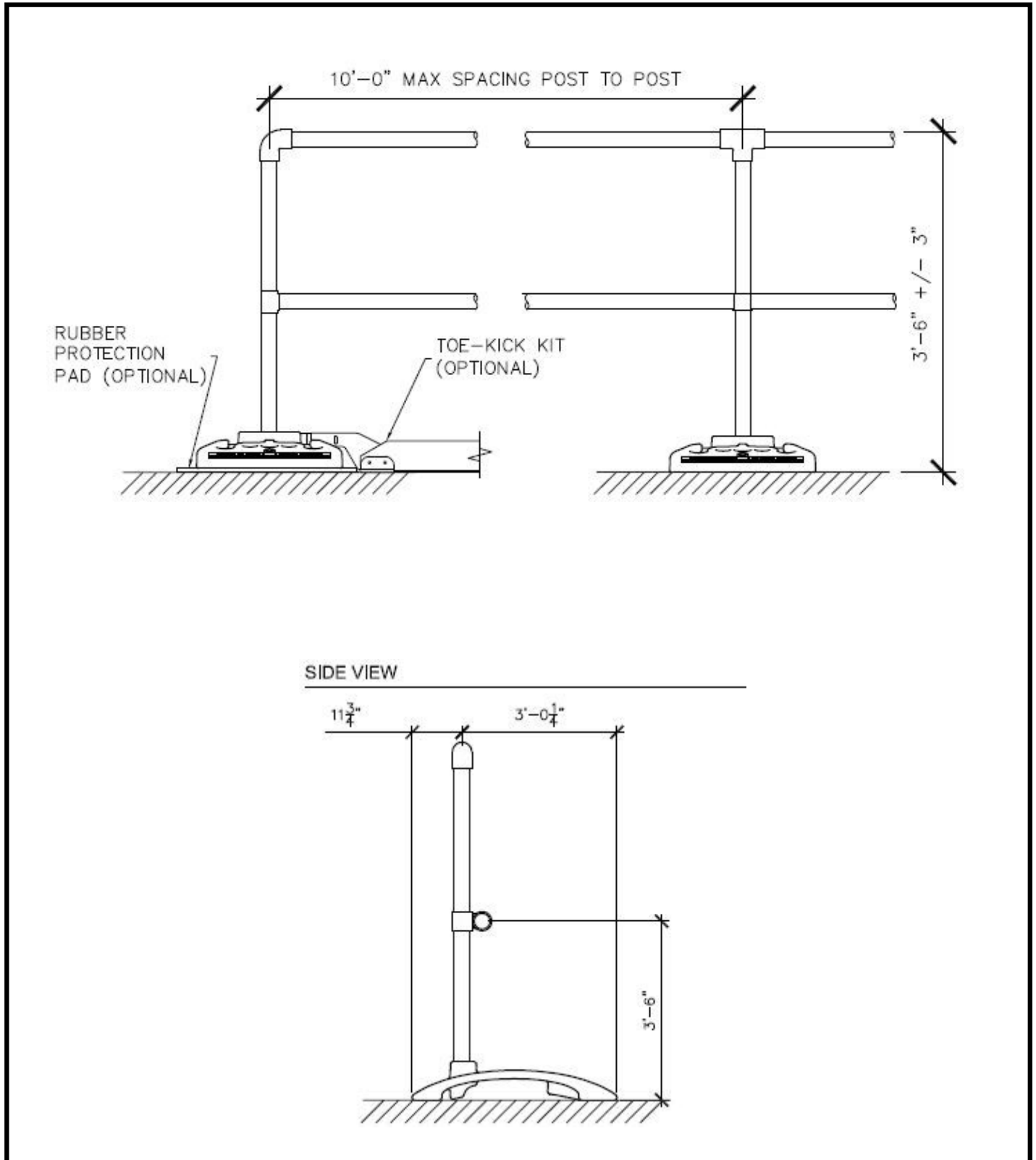
## **SAFEPRO BALLASTED GUARDRAIL PARTS LIST:**

- **(6 FOOT), (8 FOOT), (10 FOOT) GUARDRAIL PANELS:** Portable panels are formed to shape posts, top rails, and mid rails, provided as 6 feet, 8 feet and 10 feet long. Each section is 42 inches tall with a mid-rail 21 inches high. The Standard finish is powder coated safety yellow while other colors and finishes are available upon request. Refer to Figure 2.
- **MODULAR POSTS, RAILS, AND FITTINGS:** As an alternative to the guardrail panels above, Vertical Posts with pipe rails are available with integrated pipe fittings as required to form posts, top rails, and mid rails. The Standard finish is pre-galvanized steel while other colors and finishes are available upon request. Refer to Figure 1.
- **COUNTERWEIGHTED BASE:** Cast steel with three receivers that the corresponding Guardrail Panel or Vertical Post is placed within. Standard finish baseplate is hot dip galvanized.

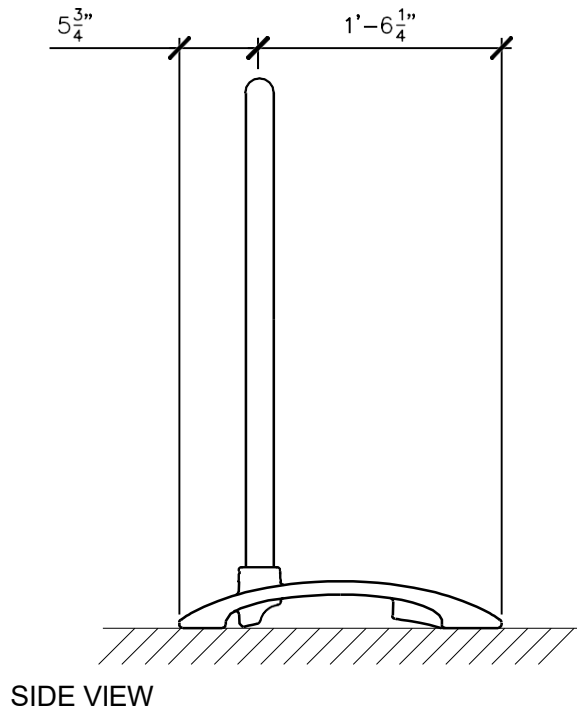
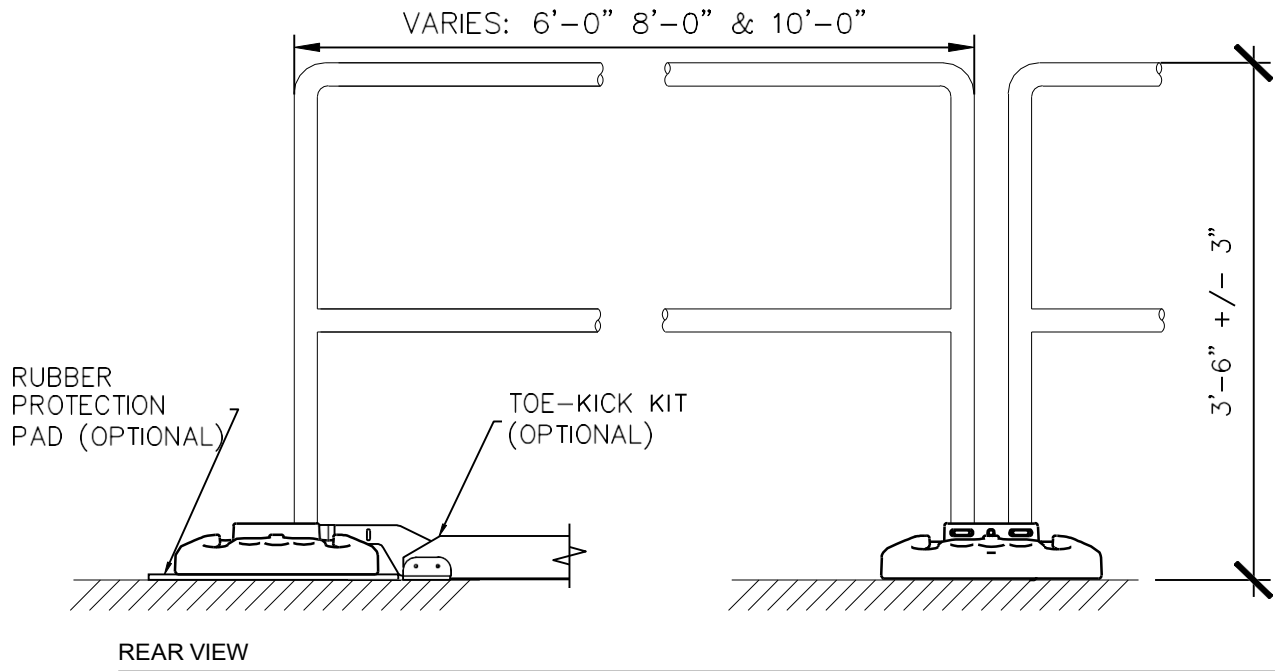
## **ADDITIONAL COMPONENTS:**

- **OPTIONAL SPLICE KIT:** The Splice Kit is a fitting used to create custom length of the SAFEPRO Guardrail Panels
- **OPTIONAL UNIVERSAL TOEBOARD BRACKET:** The Toeboard(s) is only required when it is possible objects could fall or roam from the walking/working surface to a lower level.
- **OPTIONAL RUBBER ROOF PADS:** The Rubber Roof Pad is a protective accessory that withstands environmental conditions and protects the roofing membrane surface from direct contact with the counterweighted base.
- **OPTIONAL SWING GATE:** The Swing Gate is a self-closing gate designed for use with the ballasted Guardrail System at points of entry or exit. Standard finish of the Swing Gate is powder coated safety yellow while a hot-dipped galvanized finish is also available upon request.

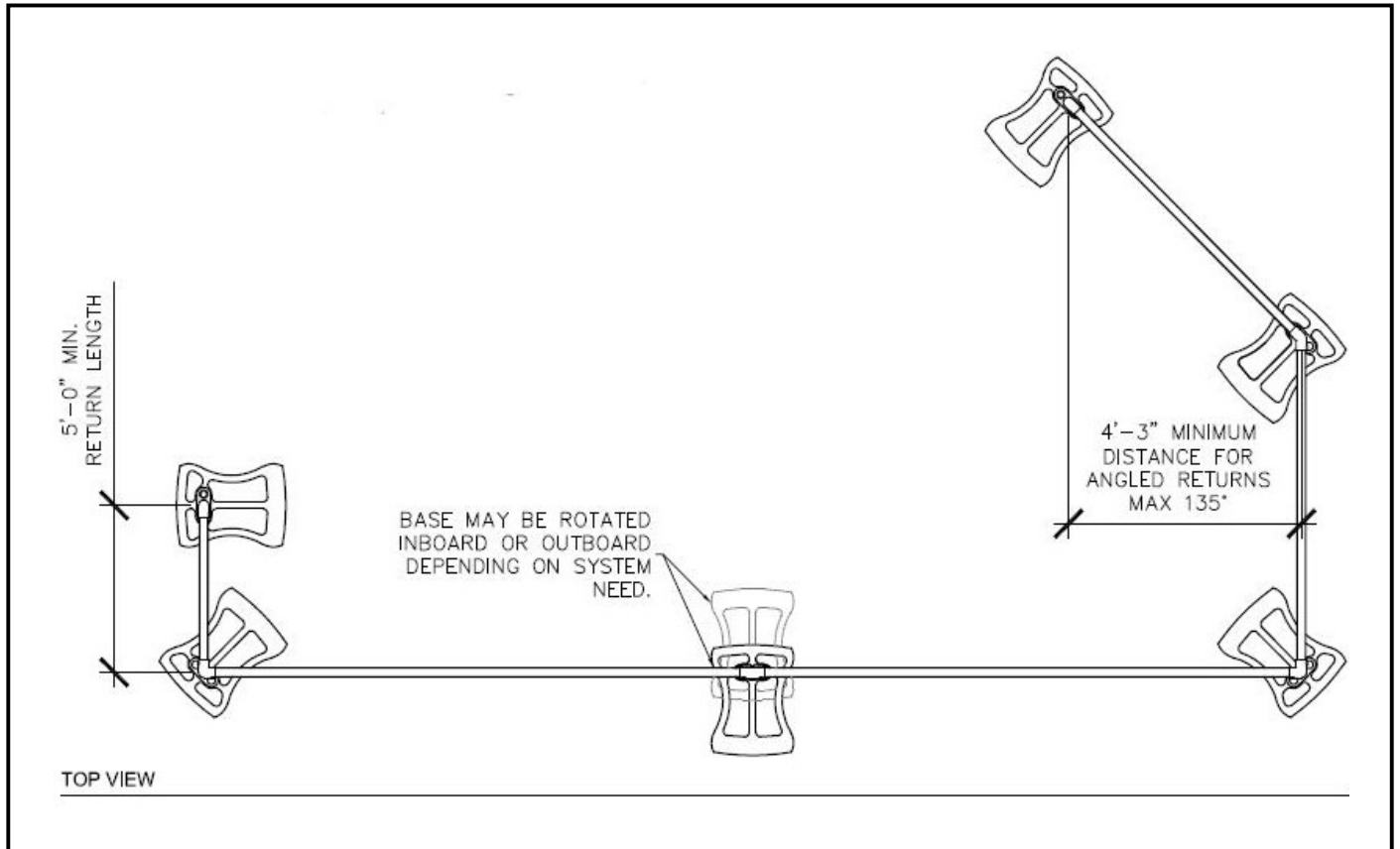
**FIGURE 1: SAFEPRO SECTION VIEWS – MODULAR SYSTEM**



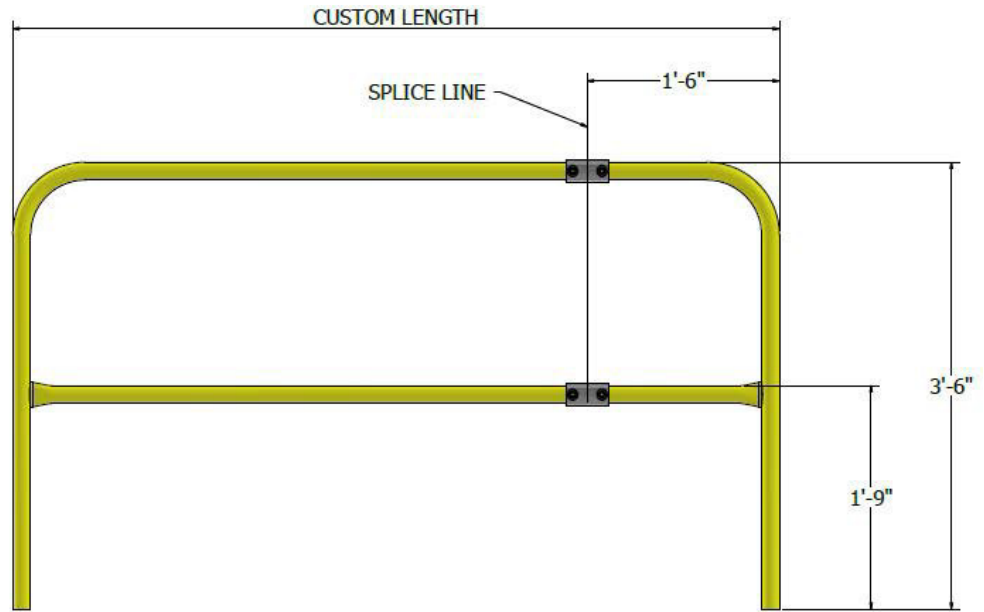
**FIGURE 2 : SAFEPRO SECTION VIEWS-PANEL SYSTEM**



**FIGURE 3: SAFEPRO BALLASTED GUARDRAIL LAYOUT TOP VIEW**

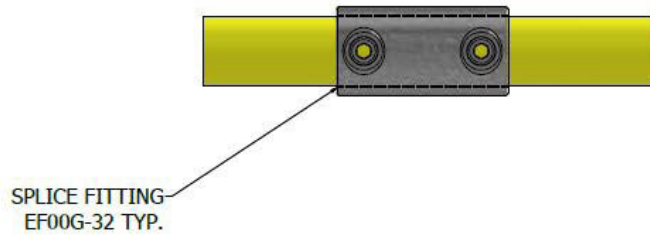


**FIGURE 4: SAFepro PANEL WITH SPLICE (CUSTOM LENGTH)**



**STEPS**

1. MEASURE LENGTH REQUIRED
2. CUT TOP AND MID RAIL AS SHOWN
3. SLIDE ON SPLICE FITTINGS
4. TIGHTEN SET SCREW TO 29 FT-LBS



## **INSTALLATION REQUIREMENTS:**

- 1. RETURNS ARE REQUIRED AT EACH SYSTEM END AND MUST BE A MINIMUM OF 5'. RETURNS MAY BE ANGLED PER FIGURE 3.**
- 2. SPACING BETWEEN POSTS MAY NOT EXCEED 10' PER FIGURE 1 AND FIGURE 2.**
- 3. TOP RAIL MUST BE 42" ( $\pm 3$ ") VERTICAL FROM THE WALKING SURFACE. THE MIDRAIL SHOULD BE MID WAY BETWEEN THE TOP RAIL AND THE HIGHEST EXPOSED EDGE. NOTE: CalOSHA PERMISSIBLE TOP RAIL HEIGHT IS DEFINED AS 41"-46".**
- 4. TOE KICKS, IF INSTALLED, SHOULD BE 1/4" OFF THE WALKING SURFACE TO PREVENT PONDING.**
- 5. SYSTEM SHOULD BE USED ON A FLAT SURFACE NOT TO EXCEED 1/2:12 PITCH.**
- 6. INTEGRATED RUBBER PROTECTION PAD MAY BE USED ON ROOF MEMBRANE FOR ROOF PROTECTION. DO NOT INSTALL ON SLIPPERY SURFACES SUCH AS METAL OR TROWEL FINISHED CONCRETE.**
- 7. REMOVE ALL LOOSE GRAVEL AND /OR MATERIALS IN THE VICINITY OF THE COUNTERWEIGHTED BASE. BASES MUST BE PLACED ON SOUND SUBSTRATE.**
- 8. WHEN PARAPET DOES NOT EXIST, FRONT EDGE OF THE BASE SHALL BE SET BACK A MINIMUM OF 18" FROM THE LEADING EDGE.**
- 9. WHERE PANEL LENGTH MUST BE REDUCED FOR PROPER LAYOUT, PANELS MAY BE MODIFIED WITH SPLICE KIT PER FIGURE 4.**
- 10. TIGHTEN ALL SET SCREWS TO 29 FT-LBS.**

## **SAFEPRO BALLASTED GUARDRAIL INSTALLATION PROCEDURES**

- Layout the job first by measuring and spacing the baseplates. Failure to properly measure and plan ahead will result in difficulty in moving the assembled system to another location.
  - Be sure the baseplates are in the correct orientation. Next, check that adequate space has been provided for Returns at each end of the system (and space for Outriggers, if applicable).
  - When satisfied with the layout, start inserting SafePro Panels or Vertical Posts (Modular System) into the base receivers. For modular system only, connect pipe rails using integrated pipe fittings.
  - Use designated Allen Wrench to tighten the set screws of the receivers at each base. Torque to 29 ft–lbs. Check tension twice on set screws to make sure they all have been tightly secured. To disassemble, reverse the process.
  - Toeboards are an optional accessory provided only upon request. Refer to toeboard section for information regarding toeboards.
- \*Approved fall protection must be utilized while installing bases and guardrails where fall hazards exist.

## **TOEBOARD BEST PRACTICES & COMPLIANCE**

### **WHEN TO USE TOEBOARDS**

- When the unprotected edge does not have a substantial barrier, like a parapet wall on a roof.
- When it is possible that materials and equipment could possibly fall off the working area, like a crew working on a HVAC unit atop a roof and near the roofs edge.
- When any of the following may occur in or around the working area:
  - o Persons can pass
  - o Moving machinery
  - o Falling materials could create a hazard
- When the above conditions exist, toeboards are to be erected along the edge of the overheadwalking/working surface for a distance sufficient to protect employees below. (OSHA 1926.502(j)(1))
- On a Continuous Run, the toeboard protection shall extend one LOGGUARD unit on either side of a work area.
- Where tools, equipment, or materials are piled higher than the top edge of a Toeboard, paneling or screening shall be erected from the walking/working surface or Toeboard to an elevation along the guardrail that is sufficient to protect employees below. (OSHA 1926.502(j)(4))

### **TOEBOARD INSTALLATION PROCEDURES**

- Commence installation and place counterweighted bases per the above Installation Procedures. Slide the toeboard over the counterweighted base receiver.
- Insert the guardrail Panel or Module into the baseplate receivers.
- It is necessary to raise the toeboard assembly at this point to tighten the setscrews for the receivers on the baseplate.

## SYSTEM INSPECTION

- System shall be inspected by an authorized person for defects, damage, or deterioration prior to each use. Periodic inspections should be conducted by a competent person at intervals not to exceed 12 months.
- Any suspected defective equipment shall be removed from service.
- If the manufacturer's label is not legible or is missing, the equipment shall be removed from service. Fall protection equipment shall be removed from service upon evidence of defects, damage, or deterioration, or upon expiration of the manufacturer's specified service limits, whichever comes first.
- Confirm proper connection of pipe to fittings and stanchions to counterweighted base receivers. If applicable, check connections to wall or roof structure.
- Initial signs of corrosion should be treated with a wire brush for removal, and subsequently apply paint or galvanizing spray as appropriate. Equipment with substantial corrosion or deterioration should be removed from service.

## DISCLAIMER

**By accepting and using this Installation Manual, you release SafePro Safety Company and its affiliates of liability. The information in this Installation Manual is provided for informational purposes only and should not be relied upon as the sole source of guidance. Although every effort was made to ensure the information in this Installation Manual is factual, SafePro Safety Company and its affiliates do not assume responsibility for errors or oversights that may result from the use of the information contained within this Installation Manual. Any person making use of the contents in this Installation Manual assumes all liability arising for such use.**



**SafePro Safety Products  
(877) 723-3570  
safeprosafety.com  
sales@safeprosafety.com**

RAL 1000	RAL 1011	RAL 1019	RAL 1033	RAL 2009	RAL 3004	RAL 3015
RAL 1001	RAL 1012	RAL 1020	RAL 1034	RAL 2010	RAL 3005	RAL 3016
RAL 1002	RAL 1013	RAL 1021	RAL 2000	RAL 2011	RAL 3007	RAL 3017
RAL 1003	RAL 1014	RAL 1023	RAL 2001	RAL 2012	RAL 3009	RAL 3018
RAL 1004	RAL 1015	RAL 1024	RAL 2002	RAL 3000	RAL 3011	RAL 3020
RAL 1005	RAL 1016	RAL 1027	RAL 2003	RAL 3001	RAL 3012	RAL 3022
RAL 1006	RAL 1017	RAL 1028	RAL 2004	RAL 3002	RAL 3013	RAL 3027
RAL 1007	RAL 1018	RAL 1032	RAL 2008	RAL 3003	RAL 3014	RAL 3031

RAL 4001	RAL 4009	RAL 5008	RAL 5017	RAL 6000	RAL 6008	RAL 6016
RAL 4002	RAL 5000	RAL 5009	RAL 5018	RAL 6001	RAL 6009	RAL 6017
RAL 4003	RAL 5001	RAL 5010	RAL 5019	RAL 6002	RAL 6010	RAL 6018
RAL 4004	RAL 5002	RAL 5011	RAL 5020	RAL 6003	RAL 6011	RAL 6019
RAL 4005	RAL 5003	RAL 5012	RAL 5021	RAL 6004	RAL 6012	RAL 6020
RAL 4006	RAL 5004	RAL 5013	RAL 5022	RAL 6005	RAL 6013	RAL 6021
RAL 4007	RAL 5005	RAL 5014	RAL 5023	RAL 6006	RAL 6014	RAL 6022
RAL 4008	RAL 5007	RAL 5015	RAL 5024	RAL 6007	RAL 6015	RAL 6024

RAL 6025	RAL 7000	RAL 7009	RAL 7022	RAL 7034	RAL 7043	RAL 8008
RAL 6026	RAL 7001	RAL 7010	RAL 7023	RAL 7035	RAL 7044	RAL 8011
RAL 6027	RAL 7002	RAL 7011	RAL 7024	RAL 7036	RAL 8000	RAL 8012
RAL 6028	RAL 7003	RAL 7012	RAL 7026	RAL 7037	RAL 8001	RAL 8014
RAL 6029	RAL 7004	RAL 7013	RAL 7030	RAL 7038	RAL 8002	RAL 8015
RAL 6032	RAL 7005	RAL 7015	RAL 7031	RAL 7039	RAL 8003	RAL 8016
RAL 6033	RAL 7006	RAL 7016	RAL 7032	RAL 7040	RAL 8004	RAL 8017
RAL 6034	RAL 7008	RAL 7021	RAL 7033	RAL 7042	RAL 8007	RAL 8019

RAL 8022	RAL 8028	RAL 9003	RAL 9011
RAL 8023		RAL 9004	RAL 9016
RAL 8024	RAL 9001	RAL 9005	RAL 9017
RAL 8025	RAL 9002	RAL 9010	RAL 9018