



## CONSTRUCTION CONTRACT

New York City  
Department of  
Environmental Protection  
59-17 Junction Boulevard  
Flushing, New York 11373

**Rohit Aggarwala**  
Commissioner

**Joseph Vaicels**  
Acting Assistant  
Commissioner Agency  
Chief Contracting Officer

### **Invitation for Bids for Furnishing all Labor and Material Necessary and Required for:**

**Contract(s):**      CRO-557G – STRUCTURES AND EQUIPMENT  
                              CRO-557H – HVAC  
                              CRO-557P – PLUMBING  
                              CRO-557E – ELECTRICAL

**Description:**      Waterfowl Management Program Building and Paving  
                              CAT-423 Reconstruction of Facilities Located in the Upstate Watershed

**Volume 1 of 2  
Contract Terms and Specifications  
(with separate Bid Booklets)**

**January 2023**

NO TEXT ON THIS PAGE

## **NOTICE TO BIDDERS**

This package of Contract Terms and Specifications includes the following:

### **EHS Notice to Bidders:**

- a. Web-based Access to BEDC Environmental, Health, and Safety (EHS) Information

### **CITY OF NEW YORK STANDARD CONSTRUCTION CONTRACT - consisting of:**

- a. Cover Sheet
- b. Rider
- c. Table of Contents (pages i to ii)
- d. Pages 1 to 105

### **REMAINDER OF THIS CONTRACT DOCUMENT - consisting of**

- a. Cover Sheet
- b. Schedule of Wage Rates
- c. General Conditions (including Schedule "A")
- d. General Specifications
- e. Detailed Specifications

**Note:** A Bid Booklet and package of Drawings for each Contract are furnished separately.

**NO TEXT ON THIS PAGE**

## Notice To Bidders

### Web-based access to BEDC EHS information

In conjunction with the requirements of Detailed Specification 01356 – Environmental, Health and Safety (EHS) Requirements, DEP’s Bureau of Engineering Design & Construction (BEDC) has provided the most recent version of DEP’s EHS Policies and Procedures, BEDC EHS Standards, and other DEP EHS guidelines and additional information on the DEP Knowledge Reservoir of the BEDC web-based Project Management Information System (PMIS) at the following website:

<https://app.e-builder.net/public/publicLanding.aspx?QS=33fcd8611637450095d280fe48f856f1>

For any question regarding the website, contact BEDC EHS at (718) 595-6228 or [bedcehs@dep.nyc.gov](mailto:bedcehs@dep.nyc.gov).

**Compliance with the latest versions of DEP EHS Policies and Procedures, BEDC EHS Standards, and DEP Guidelines are required on all DEP Contract work.**

\* \* \* \* \*

**NO TEXT FOR THIS PAGE**

**CITY OF NEW YORK**  
**STANDARD CONSTRUCTION CONTRACT**

**March 2017**

**NO TEXT ON THIS PAGE**



**RIDER TO NEW YORK CITY STANDARD CONSTRUCTION CONTRACT (MARCH 2017) REGARDING NON-COMPENSABLE DELAYS AND GROUNDS FOR EXTENSION**

[Instructions to Agencies: Please attach this Rider to the March 2017 version of the New York City Standard Construction Contract]

The following provisions supersede the corresponding provisions in the March 2017 version of the New York City Standard Construction Contract:

1. Section **11.5.1** provides as follows:

11.5.1 The acts or omissions of public or government bodies (other than **City** agencies) or of any third parties who are disclosed in the **Contract Documents**, or those third parties who are ordinarily encountered or who are generally recognized as related to the **Work**, including but not limited to, **Other Contractors**, utilities or private enterprises;

2. Section **11.5.6** provides as follows:

**11.5.6** Climatic conditions, storms, floods, droughts, tidal waves, fires, hurricanes, earthquakes, landslides or other catastrophes or acts of God; acts of war or of the public enemy or terrorist acts; disruption, outage or power failure caused by a utility's inability or failure to provide service, pandemics, epidemics, outbreaks of infectious disease or any other public health emergency; other states of emergency declared by the City, State or Federal government, quarantine restrictions, and freight embargoes; including the **City's** reasonable responses to any of the above; and

3. Section **13.3** provides as follows:

**13.3** Grounds for Extension: If such application is made, the **Contractor** shall be entitled to an extension of time for delay in completion of the **Work** caused solely:

**13.3.1** By any of the acts or omissions of the **City**, its officials, agents or employees set forth in Articles **11.4.1.1** through **11.4.1.9**; or

**13.3.2** By or attributable to any of the items set forth in Articles **11.5.1** through **11.5.7**.

**13.3.3** The **Contractor** shall, however, be entitled to an extension of time for such causes only for the number of **Days** of delay which the **ACCO** or the Board may determine to be due solely to such causes, and then only if the **Contractor** shall have strictly complied with all of the requirements of Articles 9 and 10

**NO TEXT ON THIS PAGE**

**CITY OF NEW YORK  
STANDARD CONSTRUCTION CONTRACT**

**TABLE OF CONTENTS**

CHAPTER I: THE CONTRACT AND DEFINITIONS .....	1
<b>ARTICLE 1. THE CONTRACT</b> .....	<b>1</b>
<b>ARTICLE 2. DEFINITIONS</b> .....	<b>1</b>
CHAPTER II: THE WORK AND ITS PERFORMANCE.....	4
<b>ARTICLE 3. CHARACTER OF THE WORK</b> .....	<b>4</b>
<b>ARTICLE 4. MEANS AND METHODS OF CONSTRUCTION</b> .....	<b>4</b>
<b>ARTICLE 5. COMPLIANCE WITH LAWS</b> .....	<b>5</b>
<b>ARTICLE 6. INSPECTION</b> .....	<b>10</b>
<b>ARTICLE 7. PROTECTION OF WORK AND OF PERSONS AND PROPERTY; NOTICES AND     INDEMNIFICATION</b> .....	<b>11</b>
CHAPTER III: TIME PROVISIONS .....	12
<b>ARTICLE 8. COMMENCEMENT AND PROSECUTION OF THE WORK</b> .....	<b>12</b>
<b>ARTICLE 9. PROGRESS SCHEDULES</b> .....	<b>13</b>
<b>ARTICLE 10. REQUESTS FOR INFORMATION OR APPROVAL</b> .....	<b>13</b>
<b>ARTICLE 11. NOTICE OF CONDITIONS CAUSING DELAY AND DOCUMENTATION OF     DAMAGES CAUSED BY DELAY</b> .....	<b>14</b>
<b>ARTICLE 12. COORDINATION WITH OTHER CONTRACTORS</b> .....	<b>18</b>
<b>ARTICLE 13. EXTENSION OF TIME FOR PERFORMANCE</b> .....	<b>19</b>
<b>ARTICLE 14. COMPLETION AND FINAL ACCEPTANCE OF THE WORK</b> .....	<b>21</b>
<b>ARTICLE 15. LIQUIDATED DAMAGES</b> .....	<b>23</b>
<b>ARTICLE 16. OCCUPATION OR USE PRIOR TO COMPLETION</b> .....	<b>23</b>
CHAPTER IV: SUBCONTRACTS AND ASSIGNMENTS .....	24
<b>ARTICLE 17. SUBCONTRACTS</b> .....	<b>24</b>
<b>ARTICLE 18. ASSIGNMENTS</b> .....	<b>26</b>
CHAPTER V: CONTRACTOR’S SECURITY AND GUARANTEE .....	26
<b>ARTICLE 19. SECURITY DEPOSIT</b> .....	<b>26</b>
<b>ARTICLE 20. PAYMENT GUARANTEE</b> .....	<b>27</b>
<b>ARTICLE 21. RETAINED PERCENTAGE</b> .....	<b>29</b>
<b>ARTICLE 22. INSURANCE</b> .....	<b>30</b>
<b>ARTICLE 23. MONEY RETAINED AGAINST CLAIMS</b> .....	<b>36</b>
<b>ARTICLE 24. MAINTENANCE AND GUARANTY</b> .....	<b>37</b>
CHAPTER VI: CHANGES, EXTRA WORK, AND DOCUMENTATION OF CLAIM .....	38
<b>ARTICLE 25. CHANGES</b> .....	<b>38</b>
<b>ARTICLE 26. METHODS OF PAYMENT FOR OVERRUNS AND EXTRA WORK</b> .....	<b>38</b>
<b>ARTICLE 27. RESOLUTION OF DISPUTES</b> .....	<b>41</b>
<b>ARTICLE 28. RECORD KEEPING FOR EXTRA OR DISPUTED WORK OR WORK ON A TIME &amp;     MATERIALS BASIS</b> .....	<b>45</b>
<b>ARTICLE 29. OMITTED WORK</b> .....	<b>46</b>
<b>ARTICLE 30. NOTICE AND DOCUMENTATION OF COSTS AND DAMAGES; PRODUCTION OF     FINANCIAL RECORDS</b> .....	<b>46</b>
CHAPTER VII: POWERS OF THE RESIDENT ENGINEER, THE ENGINEER OR ARCHITECT AND THE COMMISSIONER .....	48
<b>ARTICLE 31. THE RESIDENT ENGINEER</b> .....	<b>48</b>
<b>ARTICLE 32. THE ENGINEER OR ARCHITECT OR PROJECT MANAGER</b> .....	<b>48</b>
<b>ARTICLE 33. THE COMMISSIONER</b> .....	<b>48</b>
<b>ARTICLE 34. NO ESTOPPEL</b> .....	<b>49</b>
CHAPTER VIII: LABOR PROVISIONS.....	49
<b>ARTICLE 35. EMPLOYEES</b> .....	<b>49</b>
<b>ARTICLE 36. NO DISCRIMINATION</b> .....	<b>57</b>
<b>ARTICLE 37. LABOR LAW REQUIREMENTS</b> .....	<b>59</b>

ARTICLE 38. PAYROLL REPORTS .....	64
ARTICLE 39. DUST HAZARDS .....	64
CHAPTER IX: PARTIAL AND FINAL PAYMENTS .....	65
ARTICLE 40. CONTRACT PRICE .....	65
ARTICLE 41. BID BREAKDOWN ON LUMP SUM.....	65
ARTICLE 42. PARTIAL PAYMENTS .....	65
ARTICLE 43. PROMPT PAYMENT.....	66
ARTICLE 44. SUBSTANTIAL COMPLETION PAYMENT.....	66
ARTICLE 45. FINAL PAYMENT.....	67
ARTICLE 46. ACCEPTANCE OF FINAL PAYMENT .....	68
ARTICLE 47. APPROVAL BY PUBLIC DESIGN COMMISSION.....	69
CHAPTER X: CONTRACTOR'S DEFAULT .....	69
ARTICLE 48. COMMISSIONER'S RIGHT TO DECLARE CONTRACTOR IN DEFAULT .....	69
ARTICLE 49. EXERCISE OF THE RIGHT TO DECLARE DEFAULT .....	71
ARTICLE 50. QUITTING THE SITE.....	71
ARTICLE 51. COMPLETION OF THE WORK.....	71
ARTICLE 52. PARTIAL DEFAULT .....	71
ARTICLE 53. PERFORMANCE OF UNCOMPLETED WORK .....	72
ARTICLE 54. OTHER REMEDIES.....	72
CHAPTER XI: MISCELLANEOUS PROVISIONS .....	72
ARTICLE 55. CONTRACTOR'S WARRANTIES.....	72
ARTICLE 56. CLAIMS AND ACTIONS THEREON.....	73
ARTICLE 57. INFRINGEMENT .....	73
ARTICLE 58. NO CLAIM AGAINST OFFICIALS, AGENTS OR EMPLOYEES .....	74
ARTICLE 59. SERVICE OF NOTICES .....	74
ARTICLE 60. UNLAWFUL PROVISIONS DEEMED STRICKEN FROM CONTRACT.....	74
ARTICLE 61. ALL LEGAL PROVISIONS DEEMED INCLUDED .....	74
ARTICLE 62. TAX EXEMPTION .....	74
ARTICLE 63. INVESTIGATION(S) CLAUSE .....	76
ARTICLE 64. TERMINATION BY THE CITY .....	78
ARTICLE 65. CHOICE OF LAW, CONSENT TO JURISDICTION AND VENUE .....	80
ARTICLE 66. PARTICIPATION IN AN INTERNATIONAL BOYCOTT .....	81
ARTICLE 67. LOCALLY BASED ENTERPRISE PROGRAM .....	82
ARTICLE 68. ANTITRUST .....	82
ARTICLE 69. MACBRIDE PRINCIPLES PROVISIONS .....	83
ARTICLE 70. ELECTRONIC FILING/NYC DEVELOPMENT HUB .....	85
ARTICLE 71. PROHIBITION OF TROPICAL HARDWOODS.....	85
ARTICLE 72. CONFLICTS OF INTEREST.....	85
ARTICLE 73. MERGER CLAUSE .....	85
ARTICLE 74. STATEMENT OF WORK.....	85
ARTICLE 75. COMPENSATION TO BE PAID TO CONTRACTOR .....	85
ARTICLE 76. ELECTRONIC FUNDS TRANSFER.....	85
ARTICLE 77. RECORDS RETENTION .....	86
ARTICLE 78. EXAMINATION AND VIEWING OF SITE, CONSIDERATION OF OTHER SOURCES OF INFORMATION AND CHANGED SITE CONDITIONS.....	86

**WITNESSETH:**

The parties, in consideration of the mutual agreements contained herein, agree as follows:

**CHAPTER I: THE CONTRACT AND DEFINITIONS**

**ARTICLE 1. THE CONTRACT**

1.1 Except for titles, subtitles, headings, running headlines, tables of contents and indices (all of which are printed herein merely for convenience), the following, except for such portions thereof as may be specifically excluded, shall be deemed to be part of this **Contract**:

1.1.1 All provisions required by law to be inserted in this **Contract**, whether actually inserted or not;

1.1.2 The Contract Drawings and Specifications;

1.1.3 The General Conditions and Special Conditions, if any;

1.1.4 The **Contract**;

1.1.5 The Information for Bidders; Request for Proposals; Notice of Solicitation and Proposal For Bids; Bid or Proposal, and, if used, the Bid Booklet;

1.1.6 All Addenda issued prior to the receipt of the bids; the Notice of Award; Performance and Payment Bonds, if required; and the Notice to Proceed or the Order to Work.

1.2 Should any conflict occur in or between the Drawings and Specifications, the **Contractor** shall be deemed to have estimated the most expensive way of doing the **Work**, unless the **Contractor** shall have asked for and obtained a decision in writing from the **Commissioner** of the **Agency** that is entering into this **Contract**, before the submission of its bid, as to what shall govern.

**ARTICLE 2. DEFINITIONS**

2.1 The following words and expressions, or pronouns used in their stead, shall, wherever they appear in this Contract, be construed as follows, unless a different meaning is clear from the context:

2.1.1 “**Addendum**” or “**Addenda**” shall mean the additional Contract provisions and/or technical clarifications issued in writing by the Commissioner prior to the receipt of bids.

2.1.2 “**Agency**” shall mean a city, county, borough or other office, position, department, division, bureau, board or commission, or a corporation, institution or agency of government, the expenses of which are paid in whole or in part from the City treasury.

2.1.3 “**Agency Chief Contracting Officer**” (**ACCO**) shall mean a person delegated authority by the Commissioner to organize and supervise the procurement activity of subordinate Agency staff in conjunction with the CCPO, or his/her duly authorized representative.

2.1.4 **“Allowance”** shall mean a sum of money which the Agency may include in the total amount of the Contract for such specific contingencies as the Agency believes may be necessary to complete the Work, *e.g.*, lead or asbestos remediation, and for which the Contractor will be paid on the basis of stipulated unit prices or a formula set forth in the Contract or negotiated between the parties provided, however, that if the Contractor is not directed to use the Allowance, the Contractor shall have no right to such money and it shall be deducted from the total amount of the Contract.

2.1.5 **“City”** shall mean the City of New York.

2.1.6 **“City Chief Procurement Officer” (CCPO)** shall mean a person delegated authority by the Mayor to coordinate and oversee the procurement activity of Mayoral agency staff, including the ACCO and any offices which have oversight responsibility for the procurement of construction, or his/her duly authorized representative.

2.1.7 **“Commissioner”** shall mean the head of the Agency that has entered into this Contract, or his/her duly authorized representative.

2.1.8 **“Comptroller”** shall mean the Comptroller of the City of New York.

2.1.9 **“Contract”** or **“Contract Documents”** shall mean each of the various parts of the contract referred to in Article 1 hereof, both as a whole and severally.

2.1.10 **“Contract Drawings”** shall mean only those drawings specifically entitled as such and listed in the Specifications or in any Addendum, or any drawings furnished by the Commissioner, pertaining or supplemental thereto.

2.1.11 **“Contract Work”** shall mean everything required to be furnished and done by the Contractor by any one or more of the parts of the Contract referred to in Article 1, except Extra Work as hereinafter defined.

2.1.12 **“Contractor”** shall mean the entity which executed this Contract, whether a corporation, firm, partnership, joint venture, individual, or any combination thereof, and its, their, his/her successors, personal representatives, executors, administrators, and assigns, and any person, firm, partnership, joint venture, individual, or corporation which shall at any time be substituted in the place of the Contractor under this Contract.

2.1.13 **“Days”** shall mean calendar days, except where otherwise specified.

2.1.14 **“Engineer”** or **“Architect”** or **“Project Manager”** shall mean the person so designated in writing by the Commissioner in the Notice to Proceed or the Order to Work to act as such in relation to this Contract, including a private Architect or Engineer or Project Manager, as the case may be. Subject to written approval by the Commissioner, the Engineer, Architect or Project Manager may designate an authorized representative.

2.1.15 **“Engineering Audit Officer” (EAO)** shall mean the person so designated by the Commissioner to perform responsible auditing functions hereunder.

2.1.16 **“Extra Work”** shall mean Work other than that required by the Contract at the time of award which is authorized by the Commissioner pursuant to Chapter VI of this Contract.

- 2.1.17 **“Federal-Aid Contract”** shall mean a contract in which the United States (federal) Government provides financial funding as so designated in the Information for Bidders.
- 2.1.18 **“Final Acceptance”** shall mean final written acceptance of all the Work by the Commissioner, a copy of which shall be sent to the Contractor.
- 2.1.19 **“Final Approved Punch List”** shall mean a list, approved pursuant to Article 14.2.2, specifying those items of Work to be completed by the Contractor after Substantial Completion and dates for the completion of each item of Work.
- 2.1.20 **“Law”** or **“Laws”** shall mean the Constitution of the State of New York, the New York City Charter, the New York City Administrative Code, a statute of the United States or of the State of New York, a local law of the City of New York, any ordinance, rule or regulation having the force of law, or common law.
- 2.1.21 **“Materialman”** shall mean any corporation, firm, partnership, joint venture, or individual, other than employees of the Contractor, who or which contracts with the Contractor or any Subcontractor, to fabricate or deliver, or who actually fabricates or delivers, plant, materials or equipment to be incorporated in the Work.
- 2.1.22 **“Means and Methods of Construction”** shall mean the labor, materials, temporary structures, tools, plant, and construction equipment, and the manner and time of their use, necessary to accomplish the result intended by this Contract.
- 2.1.23 **“Notice to Proceed”** or **“Order to Work”** shall mean the written notice issued by the Commissioner specifying the time for commencement of the Work and the Engineer, Architect or Project Manager.
- 2.1.24 **“Other Contractor(s)”** shall mean any contractor (other than the entity which executed this Contract or its Subcontractors) who or which has a contract with the City for work on or adjacent to the building or Site of the Work.
- 2.1.25 **“Payroll Taxes”** shall mean State Unemployment Insurance (SUI), Federal Unemployment Insurance (FUI), and payments pursuant to the Federal Insurance Contributions Act (FICA).
- 2.1.26 **“Project”** shall mean the public improvement to which this Contract relates.
- 2.1.27 **“Procurement Policy Board” (PPB)** shall mean the Agency of the City of New York whose function is to establish comprehensive and consistent procurement policies and rules which shall have broad application throughout the City.
- 2.1.28 **“Required Quantity”** in a unit price Contract shall mean the actual quantity of any item of Work or materials which is required to be performed or furnished in order to comply with the Contract.
- 2.1.29 **“Resident Engineer”** shall mean the representative of the Commissioner duly designated by the Commissioner to be his/her representative at the site of the Work.
- 2.1.30 **“Site”** shall mean the area upon or in which the Contractor’s operations are carried on, and such other areas adjacent thereto as may be designated as such by the Engineer.

2.1.31 “**Small Tools**” shall mean items that are ordinarily required for a worker’s job function, including but not limited to, equipment that ordinarily has no licensing, insurance or substantive storage costs associated with it; such as circular and chain saws, impact drills, threaders, benders, wrenches, socket tools, etc.

2.1.32 “**Specifications**” shall mean all of the directions, requirements, and standards of performance applying to the Work as hereinafter detailed and designated under the Specifications.

2.1.33 “**Subcontractor**” shall mean any person, firm or corporation, other than employees of the Contractor, who or which contracts with the Contractor or with its subcontractors to furnish, or actually furnishes labor, or labor and materials, or labor and equipment, or superintendence, supervision and/or management at the Site. Wherever the word Subcontractor appears, it shall also mean sub-Subcontractor.

2.1.34 “**Substantial Completion**” shall mean the written determination by the Engineer that the Work required under this Contract is substantially, but not entirely, complete and the approval of the **Final Approved Punch List**.

2.1.35 “**Work**” shall mean all services required to complete the Project in accordance with the Contract Documents, including without limitation, labor, material, superintendence, management, administration, equipment, and incidentals, and obtaining any and all permits, certifications and licenses as may be necessary and required to complete the Work, and shall include both Contract Work and Extra Work.

## CHAPTER II: THE WORK AND ITS PERFORMANCE

### ARTICLE 3. CHARACTER OF THE WORK

3.1 Unless otherwise expressly provided in the **Contract Drawings, Specifications, and Addenda**, the **Work** shall be performed in accordance with the best modern practice, utilizing, unless otherwise specified in writing, new and unused materials of standard first grade quality and workmanship and design of the highest quality, to the satisfaction of the **Commissioner**.

### ARTICLE 4. MEANS AND METHODS OF CONSTRUCTION

4.1 Unless otherwise expressly provided in the **Contract Drawings, Specifications, and Addenda**, the **Means and Methods of Construction** shall be such as the **Contractor** may choose; subject, however, to the **Engineer’s** right to reject the **Means and Methods of Construction** proposed by the **Contractor** which in the opinion of the **Engineer**:

4.1.1 Will constitute or create a hazard to the **Work**, or to persons or property; or

4.1.2 Will not produce finished **Work** in accordance with the terms of the **Contract**; or

4.1.3 Will be detrimental to the overall progress of the **Project**.

4.2 The **Engineer’s** approval of the **Contractor’s Means and Methods of Construction**, or his/her failure to exercise his/her right to reject such means or methods, shall not relieve the **Contractor**



of its obligation to complete the **Work** as provided in this **Contract**; nor shall the exercise of such right to reject create a cause of action for damages.

## ARTICLE 5. COMPLIANCE WITH LAWS

5.1 The **Contractor** shall comply with all **Laws** applicable to this **Contract** and to the **Work** to be done hereunder.

5.2 Procurement Policy Board Rules: This **Contract** is subject to the Rules of the **PPB** (“**PPB Rules**”) in effect at the time of the bid opening for this **Contract**. In the event of a conflict between the **PPB Rules** and a provision of this **Contract**, the **PPB Rules** shall take precedence.

5.3 Noise Control Code provisions.

5.3.1 In accordance with the provisions of Section 24-216(b) of the Administrative Code of the **City** (“Administrative Code”), Noise Abatement Contract Compliance, devices and activities which will be operated, conducted, constructed or manufactured pursuant to this **Contract** and which are subject to the provisions of the **City** Noise Control Code shall be operated, conducted, constructed, or manufactured without causing a violation of the Administrative Code. Such devices and activities shall incorporate advances in the art of noise control development for the kind and level of noise emitted or produced by such devices and activities, in accordance with regulations issued by the **Commissioner** of the **City** Department of Environmental Protection.

5.3.2 The **Contractor** agrees to comply with Section 24-219 of the Administrative Code and implementing rules codified at 15 Rules of the City of New York (“RCNY”) Section 28-100 *et seq.* In accordance with such provisions, the **Contractor**, if the **Contractor** is the responsible party under such regulations, shall prepare and post a Construction Noise Mitigation Plan at each **Site**, in which the **Contractor** shall certify that all construction tools and equipment have been maintained so that they operate at normal manufacturers operating specifications. If the **Contractor** cannot make this certification, it must have in place an Alternative Noise Mitigation Plan approved by the **City** Department of Environmental Protection. In addition, the **Contractor**’s certified Construction Noise Mitigation Plan is subject inspection by the **City** Department of Environmental Protection in accordance with Section 28-101 of Title 15 of RCNY. No **Contract Work** may take place at a **Site** unless there is a Construction Noise Mitigation Plan or approved Alternative Noise Mitigation Plan in place. In addition, the **Contractor** shall create and implement a noise mitigation training program. Failure to comply with these requirements may result in fines and other penalties pursuant to the applicable provisions of the Administrative Code and RCNY.

5.4 Ultra Low Sulfur Diesel Fuel: In accordance with the provisions of Section 24-163.3 of the Administrative Code, the **Contractor** specifically agrees as follows:

5.4.1 Definitions. For purposes of this Article 5.4, the following definitions apply:

5.4.1(a) “Contractor” means any person or entity that enters into a Public Works Contract with a **City Agency**, or any person or entity that enters into an agreement with such person or entity, to perform work or provide labor or services related to such Public Works Contract.

5.4.1(b) “Motor Vehicle” means any self-propelled vehicle designed for transporting persons or property on a street or highway.

5.4.1(c) “Nonroad Engine” means an internal combustion engine (including the fuel system) that is not used in a Motor Vehicle or a vehicle used solely for competition, or that is not subject to standards promulgated under Section 7411 or Section 7521 of Title 42 of the United States Code, except that this term shall apply to internal combustion engines used to power generators, compressors or similar equipment used in any construction program or project.

5.4.1(d) “Nonroad Vehicle” means a vehicle that is powered by a Nonroad Engine, fifty (50) horsepower and greater, and that is not a Motor Vehicle or a vehicle used solely for competition, which shall include, but not be limited to, excavators, backhoes, cranes, compressors, generators, bulldozers, and similar equipment, except that this term shall not apply to horticultural maintenance vehicles used for landscaping purposes that are powered by a Nonroad Engine of sixty-five (65) horsepower or less and that are not used in any construction program or project.

5.4.1(e) “Public Works Contract” means a contract with a **City Agency** for a construction program or project involving the construction, demolition, restoration, rehabilitation, repair, renovation, or abatement of any building, structure, tunnel, excavation, roadway, park or bridge; a contract with a **City Agency** for the preparation for any construction program or project involving the construction, demolition, restoration, rehabilitation, repair, renovation, or abatement of any building, structure, tunnel, excavation, roadway, park or bridge; or a contract with a **City Agency** for any final work involved in the completion of any construction program or project involving the construction, demolition, restoration, rehabilitation, repair, renovation, or abatement of any building, structure, tunnel, excavation, roadway, park or bridge.

5.4.1(f) “Ultra Low Sulfur Diesel Fuel” means diesel fuel that has a sulfur content of no more than fifteen parts per million (15 ppm).

#### 5.4.2 Ultra Low Sulfur Diesel Fuel

5.4.2(a) All **Contractors** shall use Ultra Low Sulfur Diesel Fuel in diesel-powered Nonroad Vehicles in the performance of this **Contract**.

5.4.2(b) Notwithstanding the requirements of Article 5.4.2(a), **Contractors** may use diesel fuel that has a sulfur content of no more than thirty parts per million (30 ppm) to fulfill the requirements of this Article 5.4.2, where the Commissioner of the **City** Department of Environmental Protection (“DEP Commissioner”) has issued a determination that a sufficient quantity of Ultra Low Sulfur Diesel Fuel is not available to meet the needs of **Agencies** and **Contractors**. Any such determination shall expire after six (6) months unless renewed.

5.4.2(c) **Contractors** shall not be required to comply with this Article 5.4.2 where the **City Agency** letting this **Contract** makes a written finding, which is approved, in writing, by the DEP Commissioner, that a sufficient quantity of Ultra Low Sulfur Diesel Fuel, or diesel fuel that has a sulfur content of no more than thirty parts per million (30 ppm) is not available to meet the requirements of Section 24-163.3 of the Administrative Code, provided that such **Contractor** in its fulfillment of the

requirements of this **Contract**, to the extent practicable, shall use whatever quantity of Ultra Low Sulfur Diesel Fuel or diesel fuel that has a sulfur content of no more than thirty parts per million (30 ppm) is available. Any finding made pursuant to this Article 5.4.2(c) shall expire after sixty (60) **Days**, at which time the requirements of this Article 5.4.2 shall be in full force and effect unless the **City Agency** renews the finding in writing and such renewal is approved by the DEP Commissioner.

5.4.2(d) **Contractors** may check on determinations and approvals issued by the DEP Commissioner pursuant to Section 24-163.3 of the Administrative Code, if any, at [www.dep.nyc.gov](http://www.dep.nyc.gov) or by contacting the **City Agency** letting this **Contract**.

5.4.2(e) The requirements of this Article 5.4.2 do not apply where they are precluded by federal or State funding requirements or where the **Contract** is an emergency procurement.

#### 5.4.3 Best Available Technology

5.4.3(a) All **Contractors** shall utilize the best available technology for reducing the emission of pollutants for diesel-powered Nonroad Vehicles in the performance of this **Contract**. For determinations of best available technology for each type of diesel-powered Nonroad Vehicle, **Contractors** shall comply with the regulations of the **City** Department of Environmental Protection, as and when adopted, Chapter 14 of Title 15 of the Rules of the City of New York (RCNY). The **Contractor** shall fully document all steps in the best available technology selection process and shall furnish such documentation to the **City Agency** or the DEP Commissioner upon request. The **Contractor** shall retain all documentation generated in the best available technology selection process for as long as the selected best available technology is in use.

5.4.3(b) No **Contractor** shall be required to replace best available technology for reducing the emission of pollutants or other authorized technology utilized for a diesel-powered Nonroad Vehicle in accordance with the provisions of this Article 5.4.3 within three (3) years of having first utilized such technology for such vehicle.

5.4.3(c) This Article 5.4.3 shall not apply to any vehicle used to satisfy the requirements of a specific Public Works Contract for fewer than twenty (20) **Days**.

5.4.3(d) The **Contractor** shall not be required to comply with this Article 5.4.3 with respect to a diesel-powered Nonroad Vehicle under the following circumstances:

5.4.3(d)(i) Where the **City Agency** makes a written finding, which is approved, in writing, by the DEP Commissioner, that the best available technology for reducing the emission of pollutants as required by this Article 5.4.3 is unavailable for such vehicle, the **Contractor** shall use whatever technology for reducing the emission of pollutants, if any, is available and appropriate for such vehicle.

5.4.3(d)(ii) Where the DEP Commissioner has issued a written waiver based upon the **Contractor** having demonstrated to the DEP Commissioner that the use of the best available technology for reducing the emission of pollutants might endanger the operator of such vehicle or those working near such vehicle, due to engine malfunction, the **Contractor** shall use whatever technology for

reducing the emission of pollutants, if any, is available and appropriate for such vehicle, which would not endanger the operator of such vehicle or those working near such vehicle.

5.4.3(d)(iii) In determining which technology to use for the purposes of Articles 5.4.3(d)(i) and 5.4.3(d)(ii) above, the **Contractor** shall primarily consider the reduction in emissions of particulate matter and secondarily consider the reduction in emissions of nitrogen oxides associated with the use of such technology, which shall in no event result in an increase in the emissions of either such pollutant.

5.4.3(d)(iv) The **Contractor** shall submit requests for a finding or a waiver pursuant to this Article 5.4.3(d) in writing to the DEP Commissioner, with a copy to the **ACCO** of the **City Agency** letting this **Contract**. Any finding or waiver made or issued pursuant to Articles 5.4.3(d)(i) and 5.4.3(d)(ii) above shall expire after one hundred eighty (180) **Days**, at which time the requirements of Article 5.4.3(a) shall be in full force and effect unless the **City Agency** renews the finding, in writing, and the DEP Commissioner approves such finding, in writing, or the DEP Commissioner renews the waiver, in writing.

5.4.3(e) The requirements of this Article 5.4.3 do not apply where they are precluded by federal or State funding requirements or where the **Contract** is an emergency procurement.

5.4.4 Section 24-163 of the Administrative Code. The **Contractor** shall comply with Section 24-163 of the Administrative Code related to the idling of the engines of motor vehicles while parking.

#### 5.4.5 Compliance

5.4.5(a) The **Contractor's** compliance with Article 5.4 may be independently monitored. If it is determined that the **Contractor** has failed to comply with any provision of Article 5.4, any costs associated with any independent monitoring incurred by the **City** shall be reimbursed by the **Contractor**.

5.4.5(b) Any **Contractor** who violates any provision of Article 5.4, except as provided in Article 5.4.5(c) below, shall be liable for a civil penalty between the amounts of one thousand (\$1,000) and ten thousand (\$10,000) dollars, in addition to twice the amount of money saved by such **Contractor** for failure to comply with Article 5.4.

5.4.5(c) No **Contractor** shall make a false claim with respect to the provisions of Article 5.4 to a **City Agency**. Where a **Contractor** has been found to have done so, such **Contractor** shall be liable for a civil penalty of twenty thousand (\$20,000) dollars, in addition to twice the amount of money saved by such **Contractor** in association with having made such false claim.

#### 5.4.6 Reporting

5.4.6(a) For all Public Works Contracts covered by this Article 5.4, the **Contractor** shall report to the **City Agency** the following information:

5.4.6(a)(i) The total number of diesel-powered Nonroad Vehicles used to fulfill the requirements of this Public Works Contract;

5.4.6(a)(ii) The number of such Nonroad Vehicles that were powered by Ultra Low Sulfur Diesel Fuel;

5.4.6(a)(iii) The number of such Nonroad Vehicles that utilized the best available technology for reducing the emission of pollutants, including a breakdown by vehicle model and the type of technology;

5.4.6(a)(iv) The number of such Nonroad Vehicles that utilized such other authorized technology in accordance with Article 5.4.3, including a breakdown by vehicle model and the type of technology used for each such vehicle;

5.4.6(a)(v) The locations where such Nonroad Vehicles were used; and

5.4.6(a)(vi) Where a determination is in effect pursuant to Article 5.4.2(b) or 5.4.2(c), detailed information concerning the **Contractor's** efforts to obtain Ultra Low Sulfur Diesel Fuel or diesel fuel that has a sulfur content of no more than thirty parts per million (30 ppm).

5.4.6(b) The **Contractor** shall submit the information required by Article 5.4.6(a) at the completion of **Work** under the Public Works Contract and on a yearly basis no later than August 1 throughout the term of the Public Works Contract. The yearly report shall cover **Work** performed during the preceding fiscal year (July 1 - June 30).

5.5 Ultra Low Sulfur Diesel Fuel. In accordance with the Coordinated Construction Act for Lower Manhattan, as amended:

5.5.1 Definitions. For purposes of this Article 5.5, the following definitions apply:

5.5.1(a) "Lower Manhattan" means the area to the south of and within the following lines: a line beginning at a point where the United States pierhead line in the Hudson River as it exists now or may be extended would intersect with the southerly line of West Houston Street in the Borough of Manhattan extended, thence easterly along the southerly side of West Houston Street to the southerly side of Houston Street, thence easterly along the southerly side of Houston Street to the southerly side of East Houston Street, thence northeasterly along the southerly side of East Houston Street to the point where it would intersect with the United States pierhead line in the East River as it exists now or may be extended, including tax lots within or immediately adjacent thereto.

5.5.1(b) "Lower Manhattan Redevelopment Project" means any project in Lower Manhattan that is funded in whole or in part with federal or State funding, or any project intended to improve transportation between Lower Manhattan and the two air terminals in the **City** known as LaGuardia Airport and John F. Kennedy International Airport, or between Lower Manhattan and the air terminal in Newark known as Newark Liberty International Airport, and that is funded in whole or in part with federal funding.

5.5.1(c) “Nonroad Engine” means an internal combustion engine (including the fuel system) that is not used in a Motor Vehicle or a vehicle used solely for competition, or that is not subject to standards promulgated under Section 7411 or Section 7521 of Title 42 of the United States Code, except that this term shall apply to internal combustion engines used to power generators, compressors or similar equipment used in any construction program or project.

5.5.1(d) “Nonroad Vehicle” means a vehicle that is powered by a Nonroad Engine, fifty (50) horsepower (HP) and greater, and that is not a Motor Vehicle or a vehicle used solely for competition, which shall include, but not be limited to, excavators, backhoes, cranes, compressors, generators, bulldozers, and similar equipment, except that this terms shall not apply to horticultural maintenance vehicles used for landscaping purposes that are powered by a Nonroad Engine of sixty-five (65) HP or less and that are not used in any construction program or project.

5.5.1(e) “Ultra Low Sulfur Diesel Fuel” means diesel fuel that has a sulfur content of no more than fifteen parts per million (15 ppm).

5.5.2 Requirements. **Contractors** and **Subcontractors** are required to use only Ultra Low Sulfur Diesel Fuel to power the diesel-powered Nonroad Vehicles with engine HP rating of fifty (50) HP and above used on a Lower Manhattan Redevelopment Project and, where practicable, to reduce the emission of pollutants by retrofitting such Nonroad Vehicles with oxidation catalysts, particulate filters, or technology that achieves lowest particulate matter emissions.

5.6 Pesticides. In accordance with Section 17-1209 of the Administrative Code, to the extent that the **Contractor** or any **Subcontractor** applies pesticides to any property owned or leased by the **City**, the **Contractor**, and any **Subcontractor** shall comply with Chapter 12 of the Administrative Code.

5.7 Waste Treatment, Storage, and Disposal Facilities and Transporters. In connection with the **Work**, the **Contractor** and any **Subcontractor** shall use only those waste treatment, storage, and disposal facilities and waste transporters that possess the requisite license, permit or other governmental approval necessary to treat, store, dispose, or transport the waste, materials or hazardous substances.

5.8 Environmentally Preferable Purchasing. The **Contractor** shall ensure that products purchased or leased by the **Contractor** or any **Subcontractor** for the **Work** that are not specified by the **City** or are submitted as equivalents to a product specified by the **City** comply with the requirements of the New York City Environmentally Preferable Purchasing Program contained in Chapter 11 of Title 43 of the RCNY, pursuant to Chapter 3 of Title 6 of the Administrative Code.

## **ARTICLE 6. INSPECTION**

6.1 During the progress of the **Work** and up to the date of **Final Acceptance**, the **Contractor** shall at all times afford the representatives of the **City** every reasonable, safe, and proper facility for inspecting all **Work** done or being done at the **Site** and also for inspecting the manufacture or preparation of materials and equipment at the place of such manufacture or preparation.

6.2 The **Contractor’s** obligation hereunder shall include the uncovering or taking down of finished **Work** and its restoration thereafter; provided, however, that the order to uncover, take down and restore shall be in writing, and further provided that if **Work** thus exposed proves satisfactory, and if the **Contractor** has complied with Article 6.1, such uncovering or taking down and restoration shall be

considered an item of **Extra Work** to be paid for in accordance with the provisions of Article 26. If the **Work** thus exposed proves unsatisfactory, the **City** has no obligation to compensate the **Contractor** for the uncovering, taking down or restoration.

6.3 Inspection and approval by the **Commissioner**, the **Engineer**, **Project Manager**, or **Resident Engineer**, of finished **Work** or of **Work** being performed, or of materials and equipment at the place of manufacture or preparation, shall not relieve the **Contractor** of its obligation to perform the **Work** in strict accordance with the **Contract**. Finished or unfinished **Work** not found to be in strict accordance with the **Contract** shall be replaced as directed by the **Engineer**, even though such **Work** may have been previously approved and paid for. Such corrective **Work** is **Contract Work** and shall not be deemed **Extra Work**.

6.4 Rejected **Work** and materials shall be promptly taken down and removed from the **Site**, which must at all times be kept in a reasonably clean and neat condition.

## **ARTICLE 7. PROTECTION OF WORK AND OF PERSONS AND PROPERTY; NOTICES AND INDEMNIFICATION**

7.1 During the performance of the **Work** and up to the date of **Final Acceptance**, the **Contractor** shall be under an absolute obligation to protect the finished and unfinished **Work** against any damage, loss, injury, theft and/or vandalism and in the event of such damage, loss, injury, theft and/or vandalism, it shall promptly replace and/or repair such **Work** at the **Contractor's** sole cost and expense, as directed by the **Resident Engineer**. The obligation to deliver finished **Work** in strict accordance with the **Contract** prior to **Final Acceptance** shall be absolute and shall not be affected by the **Resident Engineer's** approval of, or failure to prohibit, the **Means and Methods of Construction** used by the **Contractor**.

7.2 During the performance of the **Work** and up to the date of **Final Acceptance**, the **Contractor** shall take all reasonable precautions to protect all persons and the property of the **City** and of others from damage, loss or injury resulting from the **Contractor's**, and/or its **Subcontractors'** operations under this **Contract**. The **Contractor's** obligation to protect shall include the duty to provide, place or replace, and adequately maintain at or about the **Site** suitable and sufficient protection such as lights, barricades, and enclosures.

7.3 The **Contractor** shall comply with the notification requirements set forth below in the event of any loss, damage or injury to **Work**, persons or property, or any accidents arising out of the operations of the **Contractor** and/or its **Subcontractors** under this **Contract**.

7.3.1 The **Contractor** shall make a full and complete report in writing to the **Resident Engineer** within three (3) **Days** after the occurrence.

7.3.2 The **Contractor** shall also send written notice of any such event to all insurance carriers that issued potentially responsive policies (including commercial general liability insurance carriers for events relating to the **Contractor's** own employees) no later than twenty (20) days after such event and again no later than twenty (20) days after the initiation of any claim and/or action resulting therefrom. Such notice shall contain the following information: the number of the insurance policy, the name of the Named Insured, the date and location of the incident, and the identity of the persons injured or property damaged. For any policy on which the **City** and/or the **Engineer**, **Architect**, or **Project Manager** are Additional Insureds, such notice shall expressly specify that "this notice is

being given on behalf of the City of New York as Additional Insured, such other Additional Insureds, as well as the Named Insured.”

7.3.2(a) Whenever such notice is sent under a policy on which the **City** is an Additional Insured, the **Contractor** shall provide copies of the notice to the **Comptroller**, the **Commissioner** and the **City** Corporation Counsel. The copy to the **Comptroller** shall be sent to the Insurance Unit, NYC Comptroller’s Office, 1 Centre Street – Room 1222, New York, New York, 10007. The copy to the **Commissioner** shall be sent to the address set forth in Schedule A of the General Conditions. The copy to the **City** Corporation Counsel shall be sent to Insurance Claims Specialist, Affirmative Litigation Division, New York City Law Department, 100 Church Street, New York, New York 10007.

7.3.2(b) If the **Contractor** fails to provide any of the foregoing notices to any appropriate insurance carrier(s) in a timely and complete manner, the **Contractor** shall indemnify the **City** for all losses, judgments, settlements, and expenses, including reasonable attorneys’ fees, arising from an insurer’s disclaimer of coverage citing late notice by or on behalf of the **City**.

7.4 To the fullest extent permitted by law, the **Contractor** shall defend, indemnify, and hold the **City**, its employees, and officials (the “Indemnitees”) harmless against any and all claims (including but not limited to claims asserted by any employee of the **Contractor** and/or its **Subcontractors**) and costs and expenses of whatever kind (including but not limited to payment or reimbursement of attorneys’ fees and disbursements) allegedly arising out of or in any way related to the operations of the **Contractor** and/or its **Subcontractors** in the performance of this **Contract** or from the **Contractor’s** and/or its **Subcontractors’** failure to comply with any of the provisions of this **Contract** or of the **Law**. Such costs and expenses shall include all those incurred in defending the underlying claim and those incurred in connection with the enforcement of this Article 7.4 by way of cross-claim, third-party claim, declaratory action or otherwise. The parties expressly agree that the indemnification obligation hereunder contemplates (1) full indemnity in the event of liability imposed against the Indemnitees without negligence and solely by reason of statute, operation of **Law** or otherwise; and (2) partial indemnity in the event of any actual negligence on the part of the Indemnitees either causing or contributing to the underlying claim (in which case, indemnification will be limited to any liability imposed over and above that percentage attributable to actual fault whether by statute, by operation of **Law**, or otherwise). Where partial indemnity is provided hereunder, all costs and expenses shall be indemnified on a pro rata basis.

7.4.1 Indemnification under Article 7.4 or any other provision of the **Contract** shall operate whether or not **Contractor** or its **Subcontractors** have placed and maintained the insurance specified under Article 22.

7.5 The provisions of this Article 7 shall not be deemed to create any new right of action in favor of third parties against the **Contractor** or the **City**.

### CHAPTER III: TIME PROVISIONS

#### ARTICLE 8. COMMENCEMENT AND PROSECUTION OF THE WORK

8.1 The **Contractor** shall commence the **Work** on the date specified in the **Notice to Proceed** or the **Order to Work**. The time for performance of the **Work** under the **Contract** shall be computed from



the date specified in the **Notice to Proceed** or the **Order to Work**. **TIME BEING OF THE ESSENCE** to the **City**, the **Contractor** shall thereafter prosecute the **Work** diligently, using such **Means and Methods of Construction** as are in accord with Article 4 herein and as will assure its completion not later than the date specified in this Contract, or on the date to which the time for completion may be extended.

#### **ARTICLE 9. PROGRESS SCHEDULES**

9.1 To enable the **Work** to be performed in an orderly and expeditious manner, the **Contractor**, within fifteen (15) **Days** after the **Notice to Proceed** or **Order to Work**, unless otherwise directed by the **Engineer**, shall submit to the **Engineer** a proposed progress schedule based on the Critical Path Method in the form of a bar graph or in such other form as specified by the **Engineer**, and monthly cash flow requirements, showing:

9.1.1 The anticipated time of commencement and completion of each of the various operations to be performed under this **Contract**; and

9.1.2 The sequence and interrelation of each of these operations with the others and with those of other related contracts; and

9.1.3 The estimated time required for fabrication or delivery, or both, of all materials and equipment required for the **Work**, including the anticipated time for obtaining required approvals pursuant to Article 10; and

9.1.4 The estimated amount in dollars the **Contractor** will claim on a monthly basis.

9.2 The proposed schedule shall be revised as directed by the **Engineer**, until finally approved by the **Engineer**, and after such approval, subject to the provisions of Article 11, shall be strictly adhered to by the **Contractor**.

9.3 If the **Contractor** shall fail to adhere to the approved progress schedule, or to the schedule as revised pursuant to Article 11, it shall promptly adopt such other or additional **Means and Methods of Construction**, at its sole cost and expense, as will make up for the time lost and will assure completion in accordance with the approved progress schedule. The approval by the **City** of a progress schedule which is shorter than the time allotted under the **Contract** shall not create any liability for the **City** if the approved progress schedule is not met.

9.4 The **Contractor** will not receive any payments until the proposed progress schedule is submitted.

#### **ARTICLE 10. REQUESTS FOR INFORMATION OR APPROVAL**

10.1 From time to time as the **Work** progresses and in the sequence indicated by the approved progress schedule, the **Contractor** shall submit to the **Engineer** a specific request in writing for each item of information or approval required by the **Contractor**. These requests shall state the latest date upon which the information or approval is actually required by the **Contractor**, and shall be submitted in a reasonable time in advance thereof to provide the **Engineer** a sufficient time to act upon such submissions, or any necessary re-submissions thereof.

10.2 The **Contractor** shall not have any right to an extension of time on account of delays due to the **Contractor's** failure to submit requests for the required information or the required approval in accordance with the above requirements.

**ARTICLE 11. NOTICE OF CONDITIONS CAUSING DELAY AND DOCUMENTATION OF DAMAGES CAUSED BY DELAY**

11.1 After the commencement of any condition which is causing or may cause a delay in completion of the **Work**, including conditions for which the **Contractor** may be entitled to an extension of time, the following notifications and submittals are required:

11.1.1 Within fifteen (15) **Days** after the **Contractor** becomes aware or reasonably should be aware of each such condition, the **Contractor** must notify the **Resident Engineer** or **Engineer**, as directed by the **Commissioner**, in writing of the existence, nature and effect of such condition upon the approved progress schedule and the **Work**, and must state why and in what respects, if any, the condition is causing or may cause a delay. Such notice shall include a description of the construction activities that are or could be affected by the condition and may include any recommendations the **Contractor** may have to address the delay condition and any activities the **Contractor** may take to avoid or minimize the delay.

11.1.2 If the **Contractor** shall claim to be sustaining damages for delay as provided for in this Article 11, within forty-five (45) **Days** from the time such damages are first incurred for each such condition, the **Contractor** shall submit to the **Commissioner** a verified written statement of the details and estimates of the amounts of such damages, including categories of expected damages and projected monthly costs, together with documentary evidence of such damages as the **Contractor** may have at the time of submission ("statement of delay damages"), as further detailed in Article 11.6. The **Contractor** may submit the above statement within such additional time as may be granted by the **Commissioner** in writing upon written request therefor.

11.1.3 Articles 11.1.1 and 11.1.2 do not relieve the **Contractor** of its obligation to comply with the provisions of Article 44.

11.2 Failure of the **Contractor** to strictly comply with the requirements of Article 11.1.1 may, in the discretion of the **Commissioner**, be deemed sufficient cause to deny any extension of time on account of delay arising out of such condition. Failure of the **Contractor** to strictly comply with the requirements of both Articles 11.1.1 and 11.1.2 shall be deemed a conclusive waiver by the **Contractor** of any and all claims for damages for delay arising from such condition and no right to recover on such claims shall exist.

11.3 When appropriate and directed by the **Engineer**, the progress schedule shall be revised by the **Contractor** until finally approved by the **Engineer**. The revised progress schedule must be strictly adhered to by the **Contractor**.

11.4 Compensable Delays

11.4.1 The **Contractor** agrees to make claim only for additional costs attributable to delay in the performance of this **Contract** necessarily extending the time for completion of the **Work** or resulting from acceleration directed by the **Commissioner** and required to maintain the progress schedule, occasioned solely by any act or omission to act of the **City** listed below. The **Contractor** also agrees that delay from any other cause shall be

compensated, if at all, solely by an extension of time to complete the performance of the **Work**.

11.4.1.1 The failure of the **City** to take reasonable measures to coordinate and progress the **Work** to the extent required by the **Contract**, except that the **City** shall not be responsible for the **Contractor's** obligation to coordinate and progress the **Work** of its **Subcontractors**.

11.4.1.2 Unreasonable delays attributable to the review of shop drawings, the issuance of change orders, or the cumulative impact of change orders that were not brought about by any act or omission of the **Contractor**.

11.4.1.3 The unavailability of the **Site** caused by acts or omissions of the **City**.

11.4.1.4 The issuance by the **Engineer** of a stop work order that was not brought about through any act or omission of the **Contractor**.

11.4.1.5 Differing site conditions or environmental hazards that were neither known nor reasonably ascertainable on a pre-bid inspection of the **Site** or review of the bid documents or other publicly available sources, and that are not ordinarily encountered in the **Project's** geographical area or neighborhood or in the type of **Work** to be performed.

11.4.1.6 Delays caused by the **City's** bad faith or its willful, malicious, or grossly negligent conduct;

11.4.1.7 Delays not contemplated by the parties;

11.4.1.8 Delays so unreasonable that they constitute an intentional abandonment of the **Contract** by the **City**; and

11.4.1.9 Delays resulting from the **City's** breach of a fundamental obligation of the **Contract**.

11.4.2 No claim may be made for any alleged delay in **Substantial Completion** of the **Work** if the **Work** will be or is substantially completed by the date of **Substantial Completion** provided for in Schedule A unless acceleration has been directed by the **Commissioner** to meet the date of **Substantial Completion** set forth in Schedule A, or unless there is a provision in the **Contract** providing for additional compensation for early completion.

11.4.3 The provisions of this Article 11 apply only to claims for additional costs attributable to delay and do not preclude determinations by the **Commissioner** allowing reimbursements for additional costs for **Extra Work** pursuant to Articles 25 and 26 of this **Contract**. To the extent that any cost attributable to delay is reimbursed as part of a change order, no additional claim for compensation under this Article 11 shall be allowed.

11.5 Non-Compensable Delays. The **Contractor** agrees to make no claim for, and is deemed to have included in its bid prices for the various items of the **Contract**, the extra/additional costs attributable to any delays caused by or attributable to the items set forth below. For such items, the **Contractor** shall be compensated, if at all, solely by an extension of time to complete the performance of the **Work**, in accordance with the provisions of Article 13. Such extensions of time will be granted, if at all, pursuant to the grounds set forth in Article 13.3.

11.5.1 The acts or omissions of any third parties, including but not limited to **Other Contractors**, public/ governmental bodies (other than **City Agencies**), utilities or private enterprises, who are disclosed in the **Contract Documents** or are ordinarily encountered or generally recognized as related to the **Work**;

11.5.2 Any situation which was within the contemplation of the parties at the time of entering into the **Contract**, including any delay indicated or disclosed in the **Contract Documents** or that would be generally recognized by a reasonably prudent contractor as related to the nature of the **Work**, and/or the existence of any facility or appurtenance owned, operated or maintained by any third party, as indicated or disclosed in the **Contract Documents** or ordinarily encountered or generally recognized as related to the nature of the **Work**;

11.5.3 Restraining orders, injunctions or judgments issued by a court which were caused by a Contractor's submission, action or inaction or by a Contractor's **Means and Methods of Construction**, or by third parties, unless such order, injunction or judgment was the result of an act or omission by the **City**;

11.5.4 Any labor boycott, strike, picketing, lockout or similar situation;

11.5.5 Any shortages of supplies or materials, or unavailability of equipment, required by the **Contract Work**;

11.5.6 Climatic conditions, storms, floods, droughts, tidal waves, fires, hurricanes, earthquakes, landslides or other catastrophes or acts of God, or acts of war or of the public enemy or terrorist acts, including the **City's** reasonable responses thereto; and

11.5.7 **Extra Work** which does not significantly affect the overall completion of the **Contract**, reasonable delays in the review or issuance of change orders or field orders and/or in shop drawing reviews or approvals.

#### 11.6 Required Content of Submission of Statement of Delay Damages

11.6.1 In the verified written statement of delay damages required by Article 11.1.2, the following information shall be provided by the **Contractor**:

11.6.1.1 For each delay, the start and end dates of the claimed periods of delay and, in addition, a description of the operations that were delayed, an explanation of how they were delayed, and the reasons for the delay, including identifying the applicable act or omission of the City listed in Article 11.4.

11.6.1.2 A detailed factual statement of the claim providing all necessary dates, locations and items of **Work** affected by the claim.

11.6.1.3 The estimated amount of additional compensation sought and a breakdown of that amount into categories as described in Article 11.7.

11.6.1.4 Any additional information requested by the **Commissioner**.

#### 11.7 Recoverable Costs

11.7.1 Delay damages may be recoverable for the following costs actually and necessarily incurred in the performance of the **Work**:

11.7.1.1 Direct labor, including payroll taxes (subject to statutory wage caps) and supplemental benefits, based on time and materials records;

11.7.1.2 Necessary materials (including transportation to the **Site**), based on time and material records;

- 11.7.1.3 Reasonable rental value of necessary plant and equipment other than small tools, plus fuel/energy costs according to the applicable formula set forth in Articles 26.2.4 and/or 26.2.8, based on time and material records;
- 11.7.1.4 Additional insurance and bond costs;
- 11.7.1.5 Extended **Site** overhead, field office rental, salaries of field office staff, on-site project managers and superintendents, field office staff vehicles, **Project**-specific storage, field office utilities and telephone, and field office consumables;
- 11.7.1.6 Labor escalation costs based on actual costs;
- 11.7.1.7 Materials and equipment escalation costs based on applicable industry indices unless documentation of actual increased cost is provided;
- 11.7.1.8 Additional material and equipment storage costs based on actual documented costs and additional costs necessitated by extended manufacturer warranty periods; and
- 11.7.1.9 Extended home office overhead calculated based on the following formula:
  - (1) Subtract from the original **Contract** amount the amount earned by original contractual **Substantial Completion** date (not including change orders);
  - (2) Remove 15% overhead and profit from the calculation in item (1) by dividing the results of item (1) by 1.15;
  - (3) Multiply the result of item (2) by 7.25% for the total home office overhead;
  - (4) Multiply the result of item (3) by 7.25% for the total profit; and
  - (5) The total extended home office overhead will be the total of items (3) and (4).

11.7.2 Recoverable Subcontractor Costs. When the **Work** is performed by a **Subcontractor**, the **Contractor** may be paid the actual and necessary costs of such subcontracted **Work** as outlined above in Articles 11.7.1.1 through 11.7.1.8, and an additional overhead of 5% of the costs outlined in Articles 11.7.1.1 through 11.7.1.3.

11.7.3 Non-Recoverable Costs. The parties agree that the **City** will have no liability for the following items and the **Contractor** agrees it shall make no claim for the following items:

- 11.7.3.1 Profit, or loss of anticipated or unanticipated profit, except as provided in Article 11.7.1.9;
- 11.7.3.2 Consequential damages, including, but not limited to, construction or bridge loans or interest paid on such loans, loss of bonding capacity, bidding opportunities, or interest in investment, or any resulting insolvency;
- 11.7.3.3 Indirect costs or expenses of any nature except those included in Article 11.7.1;
- 11.7.3.4 Direct or indirect costs attributable to performance of **Work** where the **Contractor**, because of situations or conditions within its control, has not progressed the **Work** in a satisfactory manner; and
- 11.7.3.5 Attorneys' fees and dispute and claims preparation expenses.

- 11.8 Any claims for delay under this Article 11 are not subject to the jurisdiction of the Contract Dispute Resolution Board pursuant to the dispute resolution process set forth in Article 27.
- 11.9 Any compensation provided to the **Contractor** in accordance with this Article 11 will be made pursuant to a claim filed with the **Comptroller**. Nothing in this Article 11 extends the time for the **Contractor** to file an action with respect to a claim within six months after **Substantial Completion** pursuant to Article 56.

## **ARTICLE 12. COORDINATION WITH OTHER CONTRACTORS**

12.1 During the progress of the **Work**, **Other Contractors** may be engaged in performing other work or may be awarded other contracts for additional work on this **Project**. In that event, the **Contractor** shall coordinate the **Work** to be done hereunder with the work of such **Other Contractors** and the **Contractor** shall fully cooperate with such **Other Contractors** and carefully fit its own **Work** to that provided under other contracts as may be directed by the **Engineer**. The **Contractor** shall not commit or permit any act which will interfere with the performance of work by any **Other Contractors**.

12.2 If the **Engineer** determines that the **Contractor** is failing to coordinate its **Work** with the work of **Other Contractors** as the **Engineer** has directed, then the **Commissioner** shall have the right to withhold any payments otherwise due hereunder until the **Contractor** completely complies with the **Engineer's** directions.

12.3 The **Contractor** shall notify the **Engineer** in writing if any **Other Contractor** on this **Project** is failing to coordinate its work with the **Work** of this **Contract**. If the **Engineer** finds such charges to be true, the **Engineer** shall promptly issue such directions to the **Other Contractor** with respect thereto as the situation may require. The **City** shall not, however, be liable for any damages suffered by any **Other Contractor's** failure to coordinate its work with the **Work** of this **Contract** or by reason of the **Other Contractor's** failure to promptly comply with the directions so issued by the **Engineer**, or by reason of any **Other Contractor's** default in performance, it being understood that the **City** does not guarantee the responsibility or continued efficiency of any contractor. The **Contractor** agrees to make no claim against the **City** for any damages relating to or arising out of any directions issued by the **Engineer** pursuant to this Article 12 (including but not limited to the failure of any **Other Contractor** to comply or promptly comply with such directions), or the failure of any **Other Contractor** to coordinate its work, or the default in performance of any **Other Contractor**.

12.4 The **Contractor** shall indemnify and hold the **City** harmless from any and all claims or judgments for damages and from costs and expenses to which the **City** may be subjected or which it may suffer or incur by reason of the **Contractor's** failure to comply with the **Engineer's** directions promptly; and the **Comptroller** shall have the right to exercise the powers reserved in Article 23 with respect to any claims which may be made for damages due to the **Contractor's** failure to comply with the **Engineer's** directions promptly. Insofar as the facts and **Law** relating to any claim would preclude the **City** from being completely indemnified by the **Contractor**, the **City** shall be partially indemnified by the **Contractor** to the fullest extent provided by **Law**.

12.5 Should the **Contractor** sustain any damage through any act or omission of any **Other Contractor** having a contract with the **City** for the performance of work upon the **Site** or of work which may be necessary to be performed for the proper prosecution of the **Work** to be performed hereunder, or through any act or omission of a subcontractor of such **Other Contractor**, the **Contractor** shall have no claim against the **City** for such damage, but shall have a right to recover such damage from the **Other**

**Contractor** under the provision similar to the following provisions which apply to this **Contract** and have been or will be inserted in the contracts with such **Other Contractors**:

12.5.1 Should any **Other Contractor** having or who shall hereafter have a contract with the **City** for the performance of work upon the **Site** sustain any damage through any act or omission of the **Contractor** hereunder or through any act or omission of any **Subcontractor** of the **Contractor**, the **Contractor** agrees to reimburse such **Other Contractor** for all such damages and to defend at its own expense any action based upon such claim and if any judgment or claim (even if the allegations of the action are without merit) against the **City** shall be allowed the **Contractor** shall pay or satisfy such judgment or claim and pay all costs and expenses in connection therewith and agrees to indemnify and hold the **City** harmless from all such claims. Insofar as the facts and **Law** relating to any claim would preclude the **City** from being completely indemnified by the **Contractor**, the **City** shall be partially indemnified by the **Contractor** to the fullest extent provided by **Law**.

12.6 The **City's** right to indemnification hereunder shall in no way be diminished, waived or discharged by its recourse to assessment of liquidated damages as provided in Article 15, or by the exercise of any other remedy provided for by **Contract** or by **Law**.

### **ARTICLE 13. EXTENSION OF TIME FOR PERFORMANCE**

13.1 If performance by the **Contractor** is delayed for a reason set forth in Article 13.3, the **Contractor** may be allowed a reasonable extension of time in conformance with this Article 13 and the **PPB** Rules.

13.2 Any extension of time may be granted only by the **ACCO** or by the Board for the Extension of Time (hereafter "Board") (as set forth below) upon written application by the **Contractor**.

13.3 Grounds for Extension: If such application is made, the **Contractor** shall be entitled to an extension of time for delay in completion of the **Work** caused solely:

13.3.1 By the acts or omissions of the **City**, its officials, agents or employees; or

13.3.2 By the act or omissions of **Other Contractors** on this **Project**; or

13.3.3 By supervening conditions entirely beyond the control of either party hereto (such as, but not limited to, acts of God or the public enemy, excessive inclement weather, war or other national emergency making performance temporarily impossible or illegal, or strikes or labor disputes not brought about by any act or omission of the **Contractor**).

13.3.4 The **Contractor** shall, however, be entitled to an extension of time for such causes only for the number of **Days** of delay which the **ACCO** or the Board may determine to be due solely to such causes, and then only if the **Contractor** shall have strictly complied with all of the requirements of Articles 9 and 10.

13.4 The **Contractor** shall not be entitled to receive a separate extension of time for each of several causes of delay operating concurrently, but, if at all, only for the actual period of delay in completion of the **Work** as determined by the **ACCO** or the Board, irrespective of the number of causes contributing to produce such delay. If one of several causes of delay operating concurrently results from any act, fault or omission of the **Contractor** or of its **Subcontractors** or **Materialmen**, and would of itself (irrespective

of the concurrent causes) have delayed the **Work**, no extension of time will be allowed for the period of delay resulting from such act, fault or omission.

13.5 The determination made by the **ACCO** or the Board on an application for an extension of time shall be binding and conclusive on the **Contractor**.

13.6 The **ACCO** or the Board acting entirely within their discretion may grant an application for an extension of time for causes of delay other than those herein referred.

13.7 Permitting the **Contractor** to continue with the **Work** after the time fixed for its completion has expired, or after the time to which such completion may have been extended has expired, or the making of any payment to the **Contractor** after such time, shall in no way operate as a waiver on the part of the **City** of any of its rights under this **Contract**.

#### 13.8 Application for Extension of Time:

13.8.1 Before the **Contractor's** time extension request will be considered, the **Contractor** shall notify the **ACCO** of the condition which allegedly has caused or is causing the delay, and shall submit a written application to the **ACCO** identifying:

13.8.1(a) The **Contractor**; the registration number; and **Project** description;

13.8.1(b) Liquidated damage assessment rate, as specified in the **Contract**;

13.8.1(c) Original total bid price;

13.8.1(d) The original **Contract** start date and completion date;

13.8.1(e) Any previous time extensions granted (number and duration); and

13.8.1(f) The extension of time requested.

13.8.2 In addition, the application for extension of time shall set forth in detail:

13.8.2(a) The nature of each alleged cause of delay in completing the **Work**;

13.8.2(b) The date upon which each such cause of delay began and ended and the number of **Days** attributable to each such cause;

13.8.2(c) A statement that the **Contractor** waives all claims except for those delineated in the application, and the particulars of any claims which the **Contractor** does not agree to waive. For time extensions for **Substantial Completion** and final completion payments, the application shall include a detailed statement of the dollar amounts of each element of claim item reserved; and

13.8.2(d) A statement indicating the **Contractor's** understanding that the time extension is granted only for purposes of permitting continuation of **Contract** performance and payment for **Work** performed and that the **City** retains its right to conduct an investigation and assess liquidated damages as appropriate in the future.

#### 13.9 Analysis and Approval of Time Extensions:



13.9.1 For time extensions for partial payments, a written determination shall be made by the **ACCO** who may, for good and sufficient cause, extend the time for the performance of the **Contract** as follows:

13.9.1(a) If the **Work** is to be completed within six (6) months, the time for performance may be extended for sixty (60) **Days**;

13.9.1(b) If the **Work** is to be completed within less than one (1) year but more than six (6) months, an extension of ninety (90) **Days** may be granted;

13.9.1(c) If the **Contract** period exceeds one (1) year, besides the extension granted in Article 13.9.1(b), an additional thirty (30) **Days** may be granted for each multiple of six (6) months involved beyond the one (1) year period; or

13.9.1(d) If exceptional circumstances exist, the **ACCO** may extend the time for performance beyond the extensions in Articles 13.9.1(a), 13.9.1(b), and 13.9.1(c). In that event, the **ACCO** shall file with the Mayor's Office of Contract Services a written explanation of the exceptional circumstances.

13.9.2 For extensions of time for **Substantial Completion** and final completion payments, the **Engineer**, in consultation with the **ACCO**, shall prepare a written analysis of the delay (including a preliminary determination of the causes of delay, the beginning and end dates for each such cause of delay, and whether the delays are excusable under the terms of this **Contract**). The report shall be subject to review by and approval of the Board, which shall have authority to question its analysis and determinations and request additional facts or documentation. The report as reviewed and made final by the Board shall be made a part of the **Agency** contract file. Neither the report itself nor anything contained therein shall operate as a waiver or release of any claim the **City** may have against the **Contractor** for either actual or liquidated damages.

13.9.3 Approval Mechanism for Time Extensions for **Substantial Completion** or Final Completion Payments: An extension shall be granted only with the approval of the Board which is comprised of the **ACCO** of the **Agency**, the **City** Corporation Counsel, and the **Comptroller**, or their authorized representatives.

13.9.4 Neither the granting of any application for an extension of time to the **Contractor** or any **Other Contractor** on this **Project** nor the papers, records or reports related to any application for or grant of an extension of time or determination related thereto shall be referred to or offered in evidence by the **Contractor** or its attorneys in any action or proceeding.

13.10 No Damage for Delay: The **Contractor** agrees to make no claim for damages for delay in the performance of this **Contract** occasioned by any act or omission to act of the **City** or any of its representatives, except as provided for in Article 11.

#### **ARTICLE 14. COMPLETION AND FINAL ACCEPTANCE OF THE WORK**

14.1 Date for **Substantial Completion**: The **Contractor** shall substantially complete the **Work** within the time fixed in Schedule A of the General Conditions, or within the time to which such **Substantial Completion** may be extended.

14.2 Determining the Date of **Substantial Completion**: The **Work** will be deemed to be substantially complete when the two conditions set forth below have been met.

14.2.1 Inspection: The **Engineer** or **Resident Engineer**, as applicable, has inspected the **Work** and has made a written determination that it is substantially complete.

14.2.2 Approval of **Final Approved Punch List** and Date for **Final Acceptance**: Following inspection of the **Work**, the **Engineer/Resident Engineer** shall furnish the **Contractor** with a final punch list, specifying all items of **Work** to be completed and proposing dates for the completion of each specified item of **Work**. The **Contractor** shall then submit in writing to the **Engineer/Resident Engineer** within ten (10) **Days** of the **Engineer/Resident Engineer** furnishing the final punch list either acceptance of the dates or proposed alternative dates for the completion of each specified item of **Work**. If the **Contractor** neither accepts the dates nor proposes alternative dates within ten (10) **Days**, the schedule proposed by the **Engineer/Resident Engineer** shall be deemed accepted. If the **Contractor** proposes alternative dates, then, within a reasonable time after receipt, the **Engineer/Resident Engineer**, in a written notification to the **Contractor**, shall approve the **Contractor's** completion dates or, if they are unable to agree, the **Engineer/Resident Engineer** shall establish dates for the completion of each item of **Work**. The latest completion date specified shall be the date for **Final Acceptance** of the **Work**.

14.3 Date of **Substantial Completion**. The date of approval of the **Final Approved Punch List**, shall be the date of **Substantial Completion**. The date of approval of the **Final Approved Punch List** shall be either (a) if the **Contractor** approves the final punch list and proposed dates for completion furnished by the **Engineer/Resident Engineer**, the date of the **Contractor's** approval; or (b) if the **Contractor** neither accepts the dates nor proposes alternative dates, ten (10) **Days** after the **Engineer/Resident Engineer** furnishes the **Contractor** with a final punch list and proposed dates for completion; or (c) if the **Contractor** proposes alternative dates, the date that the **Engineer/Resident Engineer** sends written notification to the **Contractor** either approving the **Contractor's** proposed alternative dates or establishing dates for the completion for each item of **Work**.

14.4 Determining the Date of **Final Acceptance**: The **Work** will be accepted as final and complete as of the date of the **Engineer's/Resident Engineer's** inspection if, upon such inspection, the **Engineer/Resident Engineer** finds that all items on the **Final Approved Punch List** are complete and no further **Work** remains to be done. The **Commissioner** will then issue a written determination of **Final Acceptance**.

14.5 Request for Inspection: Inspection of the **Work** by the **Engineer/Resident Engineer** for the purpose of **Substantial Completion** or **Final Acceptance** shall be made within fourteen (14) **Days** after receipt of the **Contractor's** written request therefor.

14.6 Request for Re-inspection: If upon inspection for the purpose of **Substantial Completion** or **Final Acceptance**, the **Engineer/Resident Engineer** determines that there are items of **Work** still to be performed, the **Contractor** shall promptly perform them and then request a re-inspection. If upon re-inspection, the **Engineer/Resident Engineer** determines that the **Work** is substantially complete or finally accepted, the date of such re-inspection shall be the date of **Substantial Completion** or **Final Acceptance**. Re-inspection by the **Engineer/Resident Engineer** shall be made within ten (10) **Days** after receipt of the **Contractor's** written request therefor.

14.7 Initiation of Inspection by the **Engineer/Resident Engineer**: If the **Contractor** does not request inspection or re-inspection of the **Work** for the purpose of **Substantial Completion** or **Final Acceptance**, the **Engineer/Resident Engineer** may initiate such inspection or re-inspection.

#### **ARTICLE 15. LIQUIDATED DAMAGES**

15.1 In the event the **Contractor** fails to substantially complete the **Work** within the time fixed for such **Substantial Completion** in Schedule A of the General Conditions, plus authorized time extensions, or if the **Contractor**, in the sole determination of the **Commissioner**, has abandoned the **Work**, the **Contractor** shall pay to the **City** the sum fixed in Schedule A of the General Conditions, for each and every **Day** that the time consumed in substantially completing the **Work** exceeds the time allowed therefor; which said sum, in view of the difficulty of accurately ascertaining the loss which the **City** will suffer by reason of delay in the **Substantial Completion** of the **Work** hereunder, is hereby fixed and agreed as the liquidated damages that the **City** will suffer by reason of such delay, and not as a penalty. This Article 15 shall also apply to the **Contractor** whether or not the **Contractor** is defaulted pursuant to Chapter X of this **Contract**. Neither the failure to assess liquidated damages nor the granting of any time extension shall operate as a waiver or release of any claim the **City** may have against the **Contractor** for either actual or liquidated damages.

15.2 Liquidated damages received hereunder are not intended to be nor shall they be treated as either a partial or full waiver or discharge of the **City's** right to indemnification, or the **Contractor's** obligation to indemnify the **City**, or to any other remedy provided for in this **Contract** or by **Law**.

15.3 The **Commissioner** may deduct and retain out of the monies which may become due hereunder, the amount of any such liquidated damages; and in case the amount which may become due hereunder shall be less than the amount of liquidated damages suffered by the **City**, the **Contractor** shall be liable to pay the difference.

#### **ARTICLE 16. OCCUPATION OR USE PRIOR TO COMPLETION**

16.1 Unless otherwise provided for in the **Specifications**, the **Commissioner** may take over, use, occupy or operate any part of the **Work** at any time prior to **Final Acceptance**, upon written notification to the **Contractor**. The **Engineer** or **Resident Engineer**, as applicable, shall inspect the part of the **Work** to be taken over, used, occupied, or operated, and will furnish the **Contractor** with a written statement of the **Work**, if any, which remains to be performed on such part. The **Contractor** shall not object to, nor interfere with, the **Commissioner's** decision to exercise the rights granted by Article 16. In the event the **Commissioner** takes over, uses, occupies, or operates any part of the **Work**:

16.1.1 the **Engineer/Resident Engineer** shall issue a written determination of **Substantial Completion** with respect to such part of the **Work**;

16.1.2 the **Contractor** shall be relieved of its absolute obligation to protect such part of the unfinished **Work** in accordance with Article 7;

16.1.3 the **Contractor's** guarantee on such part of the **Work** shall begin on the date of such use by the **City**; and;

16.1.4 the **Contractor** shall be entitled to a return of so much of the amount retained in accordance with Article 21 as it relates to such part of the **Work**, except so much thereof as may be retained under Articles 24 and 44.

## CHAPTER IV: SUBCONTRACTS AND ASSIGNMENTS

### ARTICLE 17. SUBCONTRACTS

17.1 The **Contractor** shall not make subcontracts totaling an amount more than the percentage of the total **Contract** price fixed in Schedule A of the General Conditions, without prior written permission from the **Commissioner**. All subcontracts made by the **Contractor** shall be in writing. No **Work** may be performed by a **Subcontractor** prior to the **Contractor** entering into a written subcontract with the **Subcontractor** and complying with the provisions of this Article 17.

17.2 Before making any subcontracts, the **Contractor** shall submit a written statement to the **Commissioner** giving the name and address of the proposed **Subcontractor**; the portion of the **Work** and materials which it is to perform and furnish; the cost of the subcontract; the VENDEX questionnaire if required; the proposed subcontract if requested by the **Commissioner**; and any other information tending to prove that the proposed **Subcontractor** has the necessary facilities, skill, integrity, past experience, and financial resources to perform the **Work** in accordance with the terms and conditions of this **Contract**.

17.3 In addition to the requirements in Article 17.2, **Contractor** is required to list the **Subcontractor** in the web based Subcontractor Reporting System through the City's Payee Information Portal (PIP), available at [www.nyc.gov/pip](http://www.nyc.gov/pip).<sup>1</sup> For each **Subcontractor** listed, **Contractor** is required to provide the following information: maximum contract value, description of **Subcontractor's** Work, start and end date of the subcontract and identification of the **Subcontractor's** industry. Thereafter, **Contractor** will be required to report in the system the payments made to each **Subcontractor** within 30 days of making the payment. If any of the required information changes throughout the Term of the **Contract**, **Contractor** will be required to revise the information in the system.

Failure of the **Contractor** to list a **Subcontractor** and/or to report **Subcontractor** payments in a timely fashion may result in the **Commissioner** declaring the **Contractor** in default of the **Contract** and will subject **Contractor** to liquidated damages in the amount of \$100 per day for each day that the **Contractor** fails to identify a **Subcontractor** along with the required information about the **Subcontractor** and/or fails to report payments to a **Subcontractor**, beyond the time frames set forth herein or in the notice from the **City**. Article 15 shall govern the issue of liquidated damages.

17.4 If an approved **Subcontractor** elects to subcontract any portion of its subcontract, the proposed sub-subcontract shall be submitted in the same manner as directed above.

17.5 The **Commissioner** will notify the **Contractor** in writing whether the proposed **Subcontractor** is approved. If the proposed **Subcontractor** is not approved, the **Contractor** may submit another proposed **Subcontractor** unless the **Contractor** decides to do the **Work**. No **Subcontractor** shall be permitted to enter or perform any work on the **Site** unless approved.

17.6 Before entering into any subcontract hereunder, the **Contractor** shall provide the proposed **Subcontractor** with a complete copy of this document and inform the proposed **Subcontractor** fully and completely of all provisions and requirements of this **Contract** relating either directly or indirectly to the **Work** to be performed and the materials to be furnished under such subcontract, and every such

---

<sup>1</sup> In order to use the new system, a PIP account will be required. Detailed instructions on creating a PIP account and using the new system are also available at [www.nyc.gov/pip](http://www.nyc.gov/pip). Additional assistance with PIP may be obtained by emailing the Financial Information Services Agency Help Desk at [pip@fisa.nyc.gov](mailto:pip@fisa.nyc.gov).

**Subcontractor** shall expressly stipulate that all labor performed and materials furnished by the **Subcontractor** shall strictly comply with the requirements of this **Contract**.

17.7 Documents given to a prospective **Subcontractor** for the purpose of soliciting the **Subcontractor's** bid shall include either a copy of the bid cover or a separate information sheet setting forth the **Project** name, the **Contract** number (if available), the **Agency** (as noted in Article 2.1.6), and the **Project's** location.

17.8 The **Commissioner's** approval of a **Subcontractor** shall not relieve the **Contractor** of any of its responsibilities, duties, and liabilities hereunder. The **Contractor** shall be solely responsible to the **City** for the acts or defaults of its **Subcontractor** and of such **Subcontractor's** officers, agents, and employees, each of whom shall, for this purpose, be deemed to be the agent or employee of the **Contractor** to the extent of its subcontract.

17.9 If the **Subcontractor** fails to maintain the necessary facilities, skill, integrity, past experience, and financial resources (other than due to the **Contractor's** failure to make payments where required) to perform the **Work** in accordance with the terms and conditions of this **Contract**, the **Contractor** shall promptly notify the **Commissioner** and replace such **Subcontractor** with a newly approved **Subcontractor** in accordance with this Article 17.

17.10 The **Contractor** shall be responsible for ensuring that all **Subcontractors** performing **Work** at the **Site** maintain all insurance required by **Law**.

17.11 The **Contractor** shall promptly, upon request, file with the **Engineer** a conformed copy of the subcontract and its cost. The subcontract shall provide the following:

17.11.1 Payment to **Subcontractors**: The agreement between the **Contractor** and its **Subcontractor** shall contain the same terms and conditions as to method of payment for **Work**, labor, and materials, and as to retained percentages, as are contained in this **Contract**.

17.11.2 Prevailing Rate of Wages: The agreement between the **Contractor** and its **Subcontractor** shall include the prevailing wage rates and supplemental benefits to be paid in accordance with Labor Law Section 220.

17.11.3 Section 6-123 of the Administrative Code: Pursuant to the requirements of Section 6-123 of the Administrative Code, every agreement between the **Contractor** and a **Subcontractor** in excess of fifty thousand (\$50,000) dollars shall include a provision that the **Subcontractor** shall not engage in any unlawful discriminatory practice as defined in Title VIII of the Administrative Code (Section 8-101 *et seq.*).

17.11.4 All requirements required pursuant to federal and/or state grant agreement(s), if applicable to the **Work**.

17.12 The **Commissioner** may deduct from the amounts certified under this **Contract** to be due to the **Contractor**, the sum or sums due and owing from the **Contractor** to the **Subcontractors** according to the terms of the said subcontracts, and in case of dispute between the **Contractor** and its **Subcontractor**, or **Subcontractors**, as to the amount due and owing, the **Commissioner** may deduct and withhold from the amounts certified under this **Contract** to be due to the **Contractor** such sum or sums as may be claimed by such **Subcontractor**, or **Subcontractors**, in a sworn affidavit, to be due and owing until such time as such claim or claims shall have been finally resolved.

17.13 On contracts where performance bonds and payment bonds are executed, the **Contractor** shall include on each requisition for payment the following data: **Subcontractor's** name, value of the subcontract, total amount previously paid to **Subcontractor** for **Work** previously requisitioned, and the amount, including retainage, to be paid to the **Subcontractor** for **Work** included in the requisition.

17.14 On **Contracts** where performance bonds and payment bonds are not executed, the **Contractor** shall include with each requisition for payment submitted hereunder, a signed statement from each and every **Subcontractor** and/or **Materialman** for whom payment is requested in such requisition. Such signed statement shall be on the letterhead of the **Subcontractor** and/or **Materialman** for whom payment is requested and shall (i) verify that such **Subcontractor** and/or **Materialman** has been paid in full for all **Work** performed and/or material supplied to date, exclusive of any amount retained and any amount included on the current requisition, and (ii) state the total amount of retainage to date, exclusive of any amount retained on the current requisition.

## ARTICLE 18. ASSIGNMENTS

18.1 The **Contractor** shall not assign, transfer, convey or otherwise dispose of this **Contract**, or the right to execute it, or the right, title or interest in or to it or any part thereof, or assign, by power of attorney or otherwise any of the monies due or to become due under this **Contract**, unless the previous written consent of the **Commissioner** shall first be obtained thereto, and the giving of any such consent to a particular assignment shall not dispense with the necessity of such consent to any further or other assignments.

18.2 Such assignment, transfer, conveyance or other disposition of this **Contract** shall not be valid until filed in the office of the **Commissioner** and the **Comptroller**, with the written consent of the **Commissioner** endorsed thereon or attached thereto.

18.3 Failure to obtain the previous written consent of the **Commissioner** to such an assignment, transfer, conveyance or other disposition, may result in the revocation and annulment of this **Contract**. The **City** shall thereupon be relieved and discharged from any further liability to the **Contractor**, its assignees, transferees or sublessees, who shall forfeit and lose all monies therefor earned under the **Contract**, except so much as may be required to pay the **Contractor's** employees.

18.4 The provisions of this clause shall not hinder, prevent, or affect an assignment by the **Contractor** for the benefit of its creditors made pursuant to the **Laws** of the State of New York.

18.5 This **Contract** may be assigned by the **City** to any corporation, agency or instrumentality having authority to accept such assignment.

## CHAPTER V: CONTRACTOR'S SECURITY AND GUARANTEE

### ARTICLE 19. SECURITY DEPOSIT

19.1 If performance and payment bonds are required, the **City** shall retain the bid security to ensure that the successful bidder executes the **Contract** and furnishes the required payment and performance security within ten (10) **Days** after notice of the award of the **Contract**. If the successful bidder fails to execute the **Contract** and furnish the required payment and performance security, the **City** shall retain such bid security as set forth in the Information for Bidders. If the successful bidder executes the

**Contract** and furnishes the required payment and performance security, the **City** shall return the bid security within a reasonable time after the furnishing of such bonds and execution of the **Contract** by the **City**.

19.2 If performance and payment bonds are not required, the bid security shall be retained by the **City** as security for the **Contractor**'s faithful performance of the **Contract**. If partial payments are provided, the bid security will be returned to the **Contractor** after the sum retained under Article 21 equals the amount of the bid security, subject to other provisions of this **Contract**. If partial payments are not provided, the bid security will be released when final payment is certified by the **City** for payment.

19.3 If the **Contractor** is declared in default under Article 48 prior to the return of the deposit, or if any claim is made such as referred to in Article 23, the amount of such deposit, or so much thereof as the **Comptroller** may deem necessary, may be retained and then applied by the **Comptroller**:

19.3.1 To compensate the **City** for any expense, loss or damage suffered or incurred by reason of or resulting from such default, including the cost of re-letting and liquidated damages; or

19.3.2 To indemnify the **City** against any and all claims.

## **ARTICLE 20. PAYMENT GUARANTEE**

20.1 On **Contracts** where one hundred (100%) percent performance bonds and payment bonds are executed, this Article 20 does not apply.

20.2 In the event the terms of this **Contract** do not require the **Contractor** to provide a payment bond or where the **Contract** does not require a payment bond for one hundred (100%) percent of the **Contract** price, the **City** shall, in accordance with the terms of this Article 20, guarantee payment of all lawful claims for:

20.2.1 Wages and compensation for labor performed and/or services rendered; and

20.2.2 Materials, equipment, and supplies provided, whether incorporated into the **Work** or not, when demands have been filed with the **City** as provided hereinafter by any person, firm, or corporation which furnished labor, material, equipment, supplies, or any combination thereof, in connection with the **Work** performed hereunder (hereinafter referred to as the "beneficiary") at the direction of the **City** or the **Contractor**.

20.3 The provisions of Article 20.2 are subject to the following limitations and conditions:

20.3.1 If the **Contractor** provides a payment bond for a value that is less than one hundred (100%) percent of the value of the **Contract Work**, the payment bond provided by the **Contractor** shall be primary (and non-contributing) to the payment guarantee provided under this Article 20.

20.3.2 The guarantee is made for the benefit of all beneficiaries as defined in Article 20.2 provided that those beneficiaries strictly adhere to the terms and conditions of Article 20.3.4 and 20.3.5.

20.3.3 Nothing in this Article 20 shall prevent a beneficiary providing labor, services or material for the **Work** from suing the **Contractor** for any amounts due and owing the beneficiary by the **Contractor**.

20.3.4 Every person who has furnished labor or material, to the **Contractor** or to a **Subcontractor** of the **Contractor**, in the prosecution of the **Work** and who has not been paid in full therefor before the expiration of a period of ninety (90) **Days** after the date on which the last of the labor was performed or material was furnished by him/her for which the claim is made, shall have the right to sue on this payment guarantee in his/her own name for the amount, or the balance thereof, unpaid at the time of commencement of the action; provided, however, that a person having a direct contractual relationship with a **Subcontractor** of the **Contractor** but no contractual relationship express or implied with the **Contractor** shall not have a right of action upon the guarantee unless he/she shall have given written notice to the **Contractor** within one hundred twenty (120) **Days** from the date on which the last of the labor was performed or the last of the material was furnished, for which his/her claim is made, stating with substantial accuracy the amount claimed and the name of the party to whom the material was furnished or for whom the labor was performed. The notice shall be served by delivering the same personally to the **Contractor** or by mailing the same by registered mail, postage prepaid, in an envelope addressed to the **Contractor** at any place where it maintains an office or conducts its business; provided, however, that where such notice is actually received by the **Contractor** by other means, such notice shall be deemed sufficient.

20.3.5 Except as provided in Labor Law Section 220-g, no action on this payment guarantee shall be commenced after the expiration of the one-year limitations period set forth in Section 137(4)(b) of the State Finance Law.

20.3.6 The **Contractor** shall promptly forward to the **City** any notice or demand received pursuant to Article 20.3.4. The **Contractor** shall inform the **City** of any defenses to the notice or demand and shall forward to the **City** any documents the **City** requests concerning the notice or demand.

20.3.7 All demands made against the **City** by a beneficiary of this payment guarantee shall be presented to the **Engineer** along with all written documentation concerning the demand which the **Engineer** deems reasonably appropriate or necessary, which may include, but shall not be limited to: the subcontract; any invoices presented to the **Contractor** for payment; the notarized statement of the beneficiary that the demand is due and payable, that a request for payment has been made of the **Contractor** and that the demand has not been paid by the **Contractor** within the time allowed for such payment by the subcontract; and copies of any correspondence between the beneficiary and the **Contractor** concerning such demand. The **City** shall notify the **Contractor** that a demand has been made. The **Contractor** shall inform the **City** of any defenses to the demand and shall forward to the **City** any documents the **City** requests concerning the demand.

20.3.8 The **City** shall make payment only if, after considering all defenses presented by the **Contractor**, it determines that the payment is due and owing to the beneficiary making the demand.

20.3.9 No beneficiary shall be entitled to interest from the **City**, or to any other costs, including, but not limited to, attorneys' fees, except to the extent required by State Finance Law Section 137.



20.4 Upon the receipt by the **City** of a demand pursuant to this Article 20, the **City** may withhold from any payment otherwise due and owing to the **Contractor** under this **Contract** an amount sufficient to satisfy the demand.

20.4.1 In the event the **City** determines that the demand is valid, the **City** shall notify the **Contractor** of such determination and the amount thereof and direct the **Contractor** to immediately pay such amount to the beneficiary. In the event the **Contractor**, within seven (7) **Days** of receipt of such notification from the **City**, fails to pay the beneficiary, such failure shall constitute an automatic and irrevocable assignment of payment by the **Contractor** to the beneficiary for the amount of the demand determined by the **City** to be valid. The **Contractor**, without further notification or other process, hereby gives its unconditional consent to such assignment of payment to the beneficiary and authorizes the **City**, on its behalf, to take all necessary actions to implement such assignment of payment, including without limitation the execution of any instrument or documentation necessary to effectuate such assignment.

20.4.2 In the event that the amount otherwise due and owing to the **Contractor** by the **City** is insufficient to satisfy such demand, the **City** may, at its option, require payment from the **Contractor** of an amount sufficient to cover such demand and exercise any other right to require or recover payment which the **City** may have under **Law** or **Contract**.

20.4.3 In the event the **City** determines that the demand is invalid, any amount withheld pending the **City's** review of such demand shall be paid to the **Contractor**; provided, however, no lien has been filed. In the event a claim or an action has been filed, the terms and conditions set forth in Article 23 shall apply. In the event a lien has been filed, the parties will be governed by the provisions of the Lien Law of the State of New York.

20.5 The provisions of this Article 20 shall not prevent the **City** and the **Contractor** from resolving disputes in accordance with the **PPB** Rules, where applicable.

20.6 In the event the **City** determines that the beneficiary is entitled to payment pursuant to this Article 20, such determination and any defenses and counterclaims raised by the **Contractor** shall be taken into account in evaluating the **Contractor's** performance.

20.7 Nothing in this Article 20 shall relieve the **Contractor** of the obligation to pay the claims of all persons with valid and lawful claims against the **Contractor** relating to the **Work**.

20.8 The **Contractor** shall not require any performance, payment or other bonds of any **Subcontractor** if this **Contract** does not require such bonds of the **Contractor**.

20.9 The payment guarantee made pursuant to this Article 20 shall be construed in a manner consistent with Section 137 of the State Finance Law and shall afford to persons furnishing labor or materials to the **Contractor** or its **Subcontractors** in the prosecution of the **Work** under this **Contract** all of the rights and remedies afforded to such persons by such section, including but not limited to, the right to commence an action against the **City** on the payment guarantee provided by this Article 20 within the one-year limitations period set forth in Section 137(4)(b).

## **ARTICLE 21. RETAINED PERCENTAGE**

21.1 If this **Contract** requires one hundred (100%) percent performance and payment security, then as further security for the faithful performance of this **Contract**, the **Commissioner** shall deduct, and

retain until the substantial completion of the **Work**, five (5%) percent of the value of **Work** certified for payment in each partial payment voucher.

21.2 If this **Contract** does not require one hundred (100%) percent performance and payment security and if the price for which this **Contract** was awarded does not exceed one million (\$1,000,000) dollars, then as further security for the faithful performance of this **Contract**, the **Commissioner** shall deduct, and retain until the substantial completion of the **Work**, five (5%) percent of the value of **Work** certified for payment in each partial payment voucher.

21.3 If this **Contract** does not require one hundred (100%) percent performance and payment security and if the price for which this **Contract** was awarded exceeds one million (\$1,000,000) dollars, then as further security for the faithful performance of this **Contract**, the **Commissioner** shall deduct, and retain until the substantial completion of the **Work**, up to ten (10%) percent of the value of **Work** certified for payment in each partial payment voucher. The percentage to be retained is set forth in Schedule A of the General Conditions.

## ARTICLE 22. INSURANCE

22.1 Types of Insurance: The **Contractor** shall procure and maintain the following types of insurance if, and as indicated, in Schedule A of the General Conditions (with the minimum limits and special conditions specified in Schedule A). Such insurance shall be maintained from the date the **Contractor** is required to provide Proof of Insurance pursuant to Article 22.3.1 through the date of completion of all required **Work** (including punch list work as certified in writing by the **Resident Engineer**), except for insurance required pursuant to Article 22.1.4, which may terminate upon **Substantial Completion** of the **Contract**. All insurance shall meet the requirements set forth in this Article 22. Wherever this Article requires that insurance coverage be “at least as broad” as a specified form (including all ISO forms), there is no obligation that the form itself be used, provided that the **Contractor** can demonstrate that the alternative form or endorsement contained in its policy provides coverage at least as broad as the specified form.

22.1.1 Commercial General Liability Insurance: The **Contractor** shall provide Commercial General Liability Insurance covering claims for property damage and/or bodily injury, including death, which may arise from any of the operations under this **Contract**. Coverage under this insurance shall be at least as broad as that provided by the latest edition of Insurance Services Office (“ISO”) Form CG 0001. Such insurance shall be “occurrence” based rather than “claims-made” and include, without limitation, the following types of coverage: premises operations; products and completed operations; contractual liability (including the tort liability of another assumed in a contract); broad form property damage; independent contractors; explosion, collapse and underground (XCU); construction means and methods; and incidental malpractice. Such insurance shall contain a “per project” aggregate limit, as specified in Schedule A, that applies separately to operations under this **Contract**.

22.1.1(a) Such Commercial General Liability Insurance shall name the **City** as an Additional Insured. Coverage for the City shall specifically include the **City’s** officials and employees, be at least as broad as the latest edition of ISO Form CG 20 10 and provide completed operations coverage at least as broad as the latest edition of ISO Form CG 20 37.

22.1.1(b) Such Commercial General Liability Insurance shall name all other entities designated as additional insureds in Schedule A but only for claims arising from the

**Contractor's** operations under this **Contract**, with coverage at least as broad as the latest edition of ISO Form CG 20 26.

22.1.1(c) If the **Work** requires a permit from the Department of Buildings pursuant to 1 RCNY Section 101-08, the **Contractor** shall provide Commercial General Liability Insurance with limits of at least those required by 1 RCNY section 101-08 or greater limits required by the Agency in accordance with Schedule A. If the **Work** does not require such a permit, the minimum limits shall be those provided for in Schedule A.

22.1.1(d) If any of the **Work** includes repair of a waterborne vessel owned by or to be delivered to the **City**, such Commercial General Liability shall include, or be endorsed to include, Ship Repairer's Legal Liability Coverage to protect against, without limitation, liability arising from navigation of such vessels prior to delivery to and acceptance by the **City**.

22.1.2 Workers' Compensation Insurance, Employers' Liability Insurance, and Disability Benefits Insurance: The **Contractor** shall provide, and shall cause its **Subcontractors** to provide, Workers Compensation Insurance, Employers' Liability Insurance, and Disability Benefits Insurance in accordance with the **Laws** of the State of New York on behalf of all employees providing services under this **Contract** (except for those employees, if any, for which the **Laws** require insurance only pursuant to Article 22.1.3).

22.1.3 United States Longshoremen's and Harbor Workers Act and/or Jones Act Insurance: If specified in Schedule A of the General Conditions or if required by **Law**, the **Contractor** shall provide insurance in accordance with the United States Longshoremen's and Harbor Workers Act and/or the Jones Act, on behalf of all qualifying employees providing services under this **Contract**.

22.1.4 Builders Risk Insurance: If specified in Schedule A of the General Conditions, the **Contractor** shall provide Builders Risk Insurance on a completed value form for the total value of the **Work** through **Substantial Completion** of the **Work** in its entirety. Such insurance shall be provided on an All Risk basis and include coverage, without limitation, for windstorm (including named windstorm), storm surge, flood and earth movement. Unless waived by the **Commissioner**, it shall include coverage for ordinance and law, demolition and increased costs of construction, debris removal, pollutant clean up and removal, and expediting costs. Such insurance shall cover, without limitation, (a) all buildings and/or structures involved in the **Work**, as well as temporary structures at the **Site**, and (b) any property that is intended to become a permanent part of such building or structure, whether such property is on the **Site**, in transit or in temporary storage. Policies shall name the **Contractor** as Named Insured and list the **City** as both an Additional Insured and a Loss Payee as its interest may appear.

22.1.4(a) Policies of such insurance shall specify that, in the event a loss occurs at an occupied facility, occupancy of such facility is permitted without the consent of the issuing insurance company.

22.1.4(b) Such insurance may be provided through an Installation Floater, at the **Contractor's** option, if it otherwise conforms with the requirements of this Article 22.1.4.

22.1.5 Commercial Automobile Liability Insurance: The **Contractor** shall provide Commercial Automobile Liability Insurance for liability arising out of ownership,

maintenance or use of any owned (if any), non-owned and hired vehicles to be used in connection with this **Contract**. Coverage shall be at least as broad as the latest edition of ISO Form CA0001. If vehicles are used for transporting hazardous materials, the Automobile Liability Insurance shall be endorsed to provide pollution liability broadened coverage for covered vehicles (endorsement CA 99 48) as well as proof of MCS 90.

22.1.6 Contractors Pollution Liability Insurance: If specified in Schedule A of the General Conditions, the **Contractor** shall maintain, or cause the **Subcontractor** doing such **Work** to maintain, Contractors Pollution Liability Insurance covering bodily injury and property damage. Such insurance shall provide coverage for actual, alleged or threatened emission, discharge, dispersal, seepage, release or escape of pollutants (including asbestos), including any loss, cost or expense incurred as a result of any cleanup of pollutants (including asbestos) or in the investigation, settlement or defense of any claim, action, or proceedings arising from the operations under this **Contract**. Such insurance shall be in the **Contractor's** name and list the **City** as an Additional Insured and any other entity specified in Schedule A. Coverage shall include, without limitation, (a) loss of use of damaged property or of property that has not been physically injured, (b) transportation, and (c) non-owned disposal sites.

22.1.6(a) Coverage for the **City** as Additional Insured shall specifically include the **City's** officials and employees and be at least as broad as provided to the **Contractor** for this **Project**.

22.1.6(b) If such insurance is written on a claims-made policy, such policy shall have a retroactive date on or before the effective date of this **Contract**, and continuous coverage shall be maintained, or an extended discovery period exercised, for a period of not less than three (3) years from the time the **Work** under this **Contract** is completed.

22.1.7 Marine Insurance:

22.1.7(a) Marine Protection and Indemnity Insurance: If specified in Schedule A of the General Conditions or if the **Contractor** engages in marine operations in the execution of any part of the **Work**, the **Contractor** shall maintain, or cause the **Subcontractor** doing such **Work** to maintain, Marine Protection and Indemnity Insurance with coverage at least as broad as Form SP-23. The insurance shall provide coverage for the **Contractor** or **Subcontractor** (whichever is doing this **Work**) and for the **City** (together with its officials and employees) and any other entity specified in Schedule A as an Additional Insured for bodily injury and property damage arising from marine operations under this **Contract**. Coverage shall include, without limitation, injury or death of crew members (if not fully provided through other insurance), removal of wreck, damage to piers, wharves and other fixed or floating objects and loss of or damage to any other vessel or craft, or to property on such other vessel or craft.

22.1.7(b) Hull and Machinery Insurance: If specified in Schedule A of the General Conditions or if the **Contractor** engages in marine operations in the execution of any part of the **Work**, the **Contractor** shall maintain, or cause the **Subcontractor** doing such **Work** to maintain, Hull and Machinery Insurance with coverage for the **Contractor** or **Subcontractor** (whichever is doing this **Work**) and for the **City** (together with its officials and employees) as Additional Insured at least as broad as the latest edition of American Institute Tug Form for all tugs used under this

**Contract** and Collision Liability at least as broad as the latest edition of American Institute Hull Clauses.

22.1.7(c) Marine Pollution Liability Insurance: If specified in Schedule A of the General Conditions or if the **Contractor** engages in marine operations in the execution of any part of the **Work**, the **Contractor** shall maintain, or cause the **Subcontractor** doing such Work to maintain, Marine Pollution Liability Insurance covering itself (or the Subcontractor doing such Work) as Named Insured and the **City** (together with its officials and employees) and any other entity specified in Schedule A as an Additional Insured. Coverage shall be at least as broad as that provided by the latest edition of Water Quality Insurance Syndicate Form and include, without limitation, liability arising from the discharge or substantial threat of a discharge of oil, or from the release or threatened release of a hazardous substance including injury to, or economic losses resulting from, the destruction of or damage to real property, personal property or natural resources.

22.1.8 The **Contractor** shall provide such other types of insurance, at such minimum limits and with such conditions, as are specified in Schedule A of the General Conditions.

## 22.2 General Requirements for Insurance Coverage and Policies:

22.2.1 All required insurance policies shall be maintained with companies that may lawfully issue the required policy and have an A.M. Best rating of at least A-/VII or a Standard and Poor's rating of at least A, unless prior written approval is obtained from the **City Corporation Counsel**.

22.2.2 The **Contractor** shall be solely responsible for the payment of all premiums for all required policies and all deductibles and self-insured retentions to which such policies are subject, whether or not the **City** is an insured under the policy.

22.2.3 In his/her sole discretion, the **Commissioner** may, subject to the approval of the **Comptroller** and the **City Corporation Counsel**, accept Letters of Credit and/or custodial accounts in lieu of required insurance.

22.2.4 The **City's** limits of coverage for all types of insurance required pursuant to Schedule A of the General Conditions shall be the greater of (i) the minimum limits set forth in Schedule A or (ii) the limits provided to the **Contractor** as Named Insured under all primary, excess, and umbrella policies of that type of coverage.

22.2.5 The **Contractor** may satisfy its insurance obligations under this Article 22 through primary policies or a combination of primary and excess/umbrella policies, so long as all policies provide the scope of coverage required herein.

22.2.6 Policies of insurance provided pursuant to this Article 22 shall be primary and non-contributing to any insurance or self-insurance maintained by the **City**.

## 22.3 Proof of Insurance:

22.3.1 For all types of insurance required by Article 22.1 and Schedule A, except for insurance required by Articles 22.1.4 and 22.1.7, the **Contractor** shall file proof of insurance in accordance with this Article 22.3 within ten (10) **Days** of award. For insurance

provided pursuant to Articles 22.1.4 and 22.1.7, proof shall be filed by a date specified by the **Commissioner** or ten (10) **Days** prior to the commencement of the portion of the **Work** covered by such policy, whichever is earlier.

22.3.2 For Workers' Compensation Insurance provided pursuant to Article 22.1.2, the **Contractor** shall submit one of the following forms: C-105.2 Certificate of Workers' Compensation Insurance; U-26.3 - State Insurance Fund Certificate of Workers' Compensation Insurance; Request for WC/DB Exemption (Form CE-200); equivalent or successor forms used by the New York State Workers' Compensation Board; or other proof of insurance in a form acceptable to the **Commissioner**. For Disability Benefits Insurance provided pursuant to Article 22.1.2, the Contractor shall submit DB-120.1 - Certificate Of Insurance Coverage Under The NYS Disability Benefits Law, Request for WC/DB Exemption (Form CE-200); equivalent or successor forms used by the New York State Workers' Compensation Board; or other proof of insurance in a form acceptable to the **Commissioner**. ACORD forms are not acceptable.

22.3.3 For policies provided pursuant to all of Article 22.1 other than Article 22.1.2, the **Contractor** shall submit one or more Certificates of Insurance on forms acceptable to the **Commissioner**. All such Certificates of Insurance shall certify (a) the issuance and effectiveness of such policies of insurance, each with the specified minimum limits (b) for insurance secured pursuant to Article 22.1.1 that the **City** and any other entity specified in Schedule A is an Additional Insured thereunder; (c) in the event insurance is required pursuant to Article 22.1.6 and/or Article 22.1.7, that the **City** is an Additional Insured thereunder; (d) the company code issued to the insurance company by the National Association of Insurance Commissioners (the NAIC number); and (e) the number assigned to the **Contract** by the **City**. All such Certificates of Insurance shall be accompanied by either a duly executed "Certification by Insurance Broker or Agent" in the form contained in Part III of Schedule A or copies of all policies referenced in such Certificate of Insurance as certified by an authorized representative of the issuing insurance carrier. If any policy is not available at the time of submission, certified binders may be submitted until such time as the policy is available, at which time a certified copy of the policy shall be submitted.

22.3.4 Documentation confirming renewals of insurance shall be submitted to the **Commissioner** prior to the expiration date of coverage of policies required under this **Contract**. Such proofs of insurance shall comply with the requirements of Articles 22.3.2 and 22.3.3.

22.3.5 The **Contractor** shall be obligated to provide the **City** with a copy of any policy of insurance provided pursuant to this Article 22 upon the demand for such policy by the **Commissioner** or the **City** Corporation Counsel.

#### 22.4 Operations of the **Contractor**:

22.4.1 The **Contractor** shall not commence the **Work** unless and until all required certificates have been submitted to and accepted by the **Commissioner**. Acceptance by the **Commissioner** of a certificate does not excuse the **Contractor** from securing insurance consistent with all provisions of this Article 22 or of any liability arising from its failure to do so.

22.4.2 The **Contractor** shall be responsible for providing continuous insurance coverage in the manner, form, and limits required by this **Contract** and shall be authorized to perform **Work** only during the effective period of all required coverage.

22.4.3 In the event that any of the required insurance policies lapse, are revoked, suspended or otherwise terminated, for whatever cause, the **Contractor** shall immediately stop all **Work**, and shall not recommence **Work** until authorized in writing to do so by the **Commissioner**. Upon quitting the **Site**, except as otherwise directed by the **Commissioner**, the **Contractor** shall leave all plant, materials, equipment, tools, and supplies on the **Site**. **Contract** time shall continue to run during such periods and no extensions of time will be granted. The **Commissioner** may also declare the **Contractor** in default for failure to maintain required insurance.

22.4.4 In the event the **Contractor** receives notice, from an insurance company or other person, that any insurance policy required under this Article 22 shall be cancelled or terminated (or has been cancelled or terminated) for any reason, the **Contractor** shall immediately forward a copy of such notice to both the **Commissioner** and the New York City Comptroller, attn: Office of Contract Administration, Municipal Building, One Centre Street, room 1005, New York, New York 10007. Notwithstanding the foregoing, the **Contractor** shall ensure that there is no interruption in any of the insurance coverage required under this Article 22.

22.4.5 Where notice of loss, damage, occurrence, accident, claim or suit is required under an insurance policy maintained in accordance with this Article 22, the **Contractor** shall notify in writing all insurance carriers that issued potentially responsive policies of any such event relating to any operations under this **Contract** (including notice to Commercial General Liability insurance carriers for events relating to the **Contractor's** own employees) no later than 20 days after such event. For any policy where the **City** is an Additional Insured, such notice shall expressly specify that "this notice is being given on behalf of the City of New York as Insured as well as the Named Insured." Such notice shall also contain the following information: the number of the insurance policy, the name of the named insured, the date and location of the damage, occurrence, or accident, and the identity of the persons or things injured, damaged or lost. The **Contractor** shall simultaneously send a copy of such notice to the City of New York c/o Insurance Claims Specialist, Affirmative Litigation Division, New York City Law Department, 100 Church Street, New York, New York 10007.

22.4.6 In the event of any loss, accident, claim, action, or other event that does or can give rise to a claim under any insurance policy required under this Article 22, the **Contractor** shall at all times fully cooperate with the **City** with regard to such potential or actual claim.

22.5 **Subcontractor Insurance:** In the event the **Contractor** requires any **Subcontractor** to procure insurance with regard to any operations under this **Contract** and requires such **Subcontractor** to name the **Contractor** as an **Additional Insured** thereunder, the **Contractor** shall ensure that the **Subcontractor** name the **City**, including its officials and employees, as an Additional Insured with coverage at least as broad as the most recent edition of ISO Form CG 20 26.

22.6 Wherever reference is made in Article 7 or this Article 22 to documents to be sent to the **Commissioner** (e.g., notices, filings, or submissions), such documents shall be sent to the address set forth in Schedule A of the General Conditions. In the event no address is set forth in Schedule A, such documents are to be sent to the **Commissioner's** address as provided elsewhere in this **Contract**.

22.7 Apart from damages or losses covered by insurance provided pursuant to Articles 22.1.2, 22.1.3, or 22.1.5, the **Contractor** waives all rights against the **City**, including its officials and employees, for any damages or losses that are covered under any insurance required under this Article 22 (whether or

not such insurance is actually procured or claims are paid thereunder) or any other insurance applicable to the operations of the **Contractor** and/or its employees, agents, or **Subcontractors**.

22.8 In the event the **Contractor** utilizes a self-insurance program to satisfy any of the requirements of this Article 22, the **Contractor** shall ensure that any such self-insurance program provides the **City** with all rights that would be provided by traditional insurance under this Article 22, including but not limited to the defense and indemnification obligations that insurers are required to undertake in liability policies.

22.9 Materiality/Non-Waiver: The **Contractor's** failure to secure policies in complete conformity with this Article 22, or to give an insurance company timely notice of any sort required in this **Contract** or to do anything else required by this Article 22 shall constitute a material breach of this **Contract**. Such breach shall not be waived or otherwise excused by any action or inaction by the **City** at any time.

22.10 Pursuant to General Municipal Law Section 108, this **Contract** shall be void and of no effect unless **Contractor** maintains Workers' Compensation Insurance for the term of this **Contract** to the extent required and in compliance with the New York State Workers' Compensation Law.

22.11 Other Remedies: Insurance coverage provided pursuant to this Article 22 or otherwise shall not relieve the **Contractor** of any liability under this **Contract**, nor shall it preclude the **City** from exercising any rights or taking such other actions available to it under any other provisions of this **Contract** or **Law**.

### **ARTICLE 23. MONEY RETAINED AGAINST CLAIMS**

23.1 If any claim shall be made by any person or entity (including **Other Contractors** with the **City** on this **Project**) against the **City** or against the **Contractor** and the **City** for any of the following:

- (a) An alleged loss, damage, injury, theft or vandalism of any of the kinds referred to in Articles 7 and 12, plus the reasonable costs of defending the **City**, which in the opinion of the **Comptroller** may not be paid by an insurance company (for any reason whatsoever); or
- (b) An infringement of copyrights, patents or use of patented articles, tools, etc., as referred to in Article 57; or
- (c) Damage claimed to have been caused directly or indirectly by the failure of the **Contractor** to perform the **Work** in strict accordance with this **Contract**,

the amount of such claim, or so much thereof as the **Comptroller** may deem necessary, may be withheld by the **Comptroller**, as security against such claim, from any money due hereunder. The **Comptroller**, in his/her discretion, may permit the **Contractor** to substitute other satisfactory security in lieu of the monies so withheld.

23.2 If an action on such claim is timely commenced and the liability of the **City**, or the **Contractor**, or both, shall have been established therein by a final judgment of a court of competent jurisdiction, or if such claim shall have been admitted by the **Contractor** to be valid, the **Comptroller** shall pay such judgment or admitted claim out of the monies retained by the **Comptroller** under the provisions of this Article 23, and return the balance, if any, without interest, to the **Contractor**.



## ARTICLE 24. MAINTENANCE AND GUARANTY

24.1 The **Contractor** shall promptly repair, replace, restore or rebuild, as the **Commissioner** may determine, any finished **Work** in which defects of materials or workmanship may appear or to which damage may occur because of such defects, during the one (1) year period subsequent to the date of **Substantial Completion** (or use and occupancy in accordance with Article 16), except where other periods of maintenance and guaranty are provided for in Schedule A.

24.2 As security for the faithful performance of its obligations hereunder, the **Contractor**, upon filing its requisition for payment on **Substantial Completion**, shall deposit with the **Commissioner** a sum equal to one (1%) percent of the price (or the amount fixed in Schedule A of the General Conditions) in cash or certified check upon a state or national bank and trust company or a check of such bank and trust company signed by a duly authorized officer thereof and drawn to the order of the **Comptroller**, or obligations of the **City**, which the **Comptroller** may approve as of equal value with the sum so required.

24.3 In lieu of the above, the **Contractor** may make such security payment to the **City** by authorizing the **Commissioner** in writing to deduct the amount from the **Substantial Completion** payment which shall be deemed the deposit required above.

24.4 If the **Contractor** has faithfully performed all of its obligations hereunder the **Commissioner** shall so certify to the **Comptroller** within five (5) **Days** after the expiration of one (1) year from the date of **Substantial Completion** and acceptance of the **Work** or within thirty (30) **Days** after the expiration of the guarantee period fixed in the **Specifications**. The security payment shall be repaid to the **Contractor** without interest within thirty (30) **Days** after certification by the **Commissioner** to the **Comptroller** that the **Contractor** has faithfully performed all of its obligations hereunder.

24.5 Notice by the **Commissioner** to the **Contractor** to repair, replace, rebuild or restore such defective or damaged **Work** shall be timely, pursuant to this article, if given not later than ten (10) **Days** subsequent to the expiration of the one (1) year period or other periods provided for herein.

24.6 If the **Contractor** shall fail to repair, replace, rebuild or restore such defective or damaged **Work** promptly after receiving such notice, the **Commissioner** shall have the right to have the **Work** done by others in the same manner as provided for in the completion of a defaulted **Contract**, under Article 51.

24.7 If the security payment so deposited is insufficient to cover the cost of such **Work**, the **Contractor** shall be liable to pay such deficiency on demand by the **Commissioner**.

24.8 The **Engineer's** certificate setting forth the fair and reasonable cost of repairing, replacing, rebuilding or restoring any damaged or defective **Work** when performed by one other than the **Contractor**, shall be binding and conclusive upon the **Contractor** as to the amount thereof.

24.9 The **Contractor** shall obtain all manufacturers' warranties and guaranties of all equipment and materials required by this **Contract** in the name of the **City** and shall deliver same to the **Commissioner**. All of the **City's** rights and title and interest in and to said manufacturers' warranties and guaranties may be assigned by the **City** to any subsequent purchasers of such equipment and materials or lessees of the premises into which the equipment and materials have been installed.

## CHAPTER VI: CHANGES, EXTRA WORK, AND DOCUMENTATION OF CLAIM

### ARTICLE 25. CHANGES

25.1 Changes may be made to this **Contract** only as duly authorized in writing by the **Commissioner** in accordance with the **Law** and this **Contract**. All such changes, modifications, and amendments will become a part of the **Contract**. **Work** so ordered shall be performed by the **Contractor**.

25.2 **Contract** changes will be made only for **Work** necessary to complete the **Work** included in the original scope of the **Contract** and/or for non-material changes to the scope of the **Contract**. Changes are not permitted for any material alteration in the scope of **Work** in the **Contract**.

25.3 The **Contractor** shall be entitled to a price adjustment for **Extra Work** performed pursuant to a written change order. Adjustments to price shall be computed in one or more of the following ways:

25.3.1 By applicable unit prices specified in the **Contract**; and/or

25.3.2 By agreement of a fixed price; and/or

25.3.3 By time and material records; and/or

25.3.4 In any other manner approved by the **CCPO**.

25.4 All payments for change orders are subject to pre-audit by the **Engineering Audit Officer** and may be post-audited by the **Comptroller** and/or the **Agency**.

### ARTICLE 26. METHODS OF PAYMENT FOR OVERRUNS AND EXTRA WORK

26.1 Overrun of Unit Price Item: An overrun is any quantity of a unit price item which the **Contractor** is directed to provide which is in excess of one hundred twenty-five (125%) percent of the estimated quantity for that item set forth in the bid schedule.

26.1.1 For any unit price item, the **Contractor** will be paid at the unit price bid for any quantity up to one hundred twenty-five (125%) percent of the estimated quantity for that item set forth in the bid schedule. If during the progress of the **Work**, the actual quantity of any unit price item required to complete the **Work** approaches the estimated quantity for that item, and for any reason it appears that the actual quantity of any unit price item necessary to complete the **Work** will exceed the estimated quantity for that item by twenty-five (25%) percent, the **Contractor** shall immediately notify the **Engineer** of such anticipated overrun. The **Contractor** shall not be compensated for any quantity of a unit price item provided which is in excess of one hundred twenty-five (125%) percent of the estimated quantity for that item set forth in the bid schedule without written authorization from the **Engineer**.

26.1.2 If the actual quantity of any unit price item necessary to complete the **Work** will exceed one hundred twenty five (125%) percent of the estimated quantity for that item set forth in the bid schedule, the **City** reserves the right and the **Contractor** agrees to negotiate a new unit price for such item. In no event shall such negotiated new unit price exceed the unit bid price. If the **City** and **Contractor** cannot agree on a new unit price, then the **City** shall order the **Contractor** and the **Contractor** agrees to provide additional quantities of

the item on the basis of time and material records for the actual and reasonable cost as determined under Article 26.2, but in no event at a unit price exceeding the unit price bid.

**26.2 Extra Work:** For **Extra Work** where payment is by agreement on a fixed price in accordance with Article 25.3.2, the price to be paid for such **Extra Work** shall be based on the fair and reasonable estimated cost of the items set forth below. For **Extra Work** where payment is based on time and material records in accordance with Article 25.3.3, the price to be paid for such **Extra Work** shall be the actual and reasonable cost of the items set forth below, calculated in accordance with the formula specified therein, if any.

26.2.1 Necessary materials (including transportation to the **Site**); plus

26.2.2 Necessary direct labor, including payroll taxes (subject to statutory wage caps) and supplemental benefits; plus

26.2.3 Sales and personal property taxes, if any, required to be paid on materials not incorporated into such **Extra Work**; plus

26.2.4 Reasonable rental value of **Contractor**-owned (or **Subcontractor**-owned, as applicable), necessary plant and equipment other than **Small Tools**, plus fuel/energy costs. Except for fuel costs for pick-up trucks which shall be reimbursed based on a consumption of five (5) gallons per shift, fuel costs shall be reimbursed based on actual costs or, in the absence of auditable documentation, the following fuel consumption formula per operating hour:  $(.035) \times (\text{HP rating}) \times (\text{Fuel cost/gallon})$ . Reasonable rental value is defined as the lower of either seventy-five percent of the monthly prorated rental rates established in "The AED Green Book, Rental Rates and Specifications for Construction Equipment" published by Equipment Watch (the "Green Book"), or seventy-five percent of the monthly prorated rental rates established in the "Rental Rate Blue Book for Construction Equipment" published by Equipment Watch (the "Blue Book") (the applicable Blue Book rate being for rental only without the addition of any operational costs listed in the Blue Book). The reasonable rental value is deemed to be inclusive of all operating costs except for fuel/energy consumption and equipment operator's wages/costs. For multiple shift utilization, reimbursement shall be calculated as follows: first shift shall be seventy-five (75%) percent of such rental rates; second shift shall be sixty (60%) percent of the first shift rate; and third shift shall be forty (40%) percent of the first shift rate. Equipment on standby shall be reimbursed at one-third (1/3) the prorated monthly rental rate. **Contractor**-owned (or **Subcontractor**-owned, as applicable) equipment includes equipment from rental companies affiliated with or controlled by the **Contractor** (or **Subcontractor**, as applicable), as determined by the **Commissioner**. In establishing cost reimbursement for non-operating **Contractor**-owned (or **Subcontractor**-owned, as applicable) equipment (scaffolding, sheeting systems, road plates, etc.), the **City** may restrict reimbursement to a purchase-salvage/life cycle basis if less than the computed rental costs; plus

26.2.5 Necessary installation and dismantling of such plant and equipment, including transportation to and from the **Site**, if any, provided that, in the case of non-**Contractor**-owned (or non-**Subcontractor**-owned, as applicable) equipment rented from a third party, the cost of installation and dismantling are not allowable if such costs are included in the rental rate; plus

26.2.6 Necessary fees charged by governmental entities; plus

26.2.7 Necessary construction-related service fees charged by non-governmental entities, such as landfill tipping fees; plus

26.2.8 Reasonable rental costs of non-**Contractor**-owned (or non-**Subcontractor**-owned, as applicable) necessary plant and equipment other than **Small Tools**, plus fuel/energy costs. Except for fuel costs for pick-up trucks which shall be reimbursed based on a consumption of five (5) gallons per shift, fuel costs shall be reimbursed based on actual costs or, in the absence of auditable documentation, the following fuel consumption formula per hour of operation:  $(.035) \times (\text{HP rating}) \times (\text{Fuel cost/gallon})$ . In lieu of renting, the **City** reserves the right to direct the purchase of non-operating equipment (scaffolding, sheeting systems, road plates, etc.), with payment on a purchase-salvage/life cycle basis, if less than the projected rental costs; plus

26.2.9 Workers' Compensation Insurance, and any insurance coverage expressly required by the **City** for the performance of the **Extra Work** which is different than the types of insurance required by Article 22 and Schedule A of the General Conditions. The cost of Workers' Compensation Insurance is subject to applicable payroll limitation caps and shall be based upon the carrier's Manual Rate for such insurance derived from the applicable class Loss Cost ("LC") and carrier's Lost Cost Multiplier ("LCM") approved by the New York State Department of Financial Services, and with the exception of experience rating, rate modifiers as promulgated by the New York Compensation Insurance Rating Board ("NYCIRB"); plus

26.2.10 Additional costs incurred as a result of the **Extra Work** for performance and payment bonds; plus

26.2.11 Twelve percent (12%) percent of the total of items in Articles 26.2.1 through 26.2.5 as compensation for overhead, except that no percentage for overhead will be allowed on **Payroll Taxes** or on the premium portion of overtime pay or on sales and personal property taxes. Overhead shall include without limitation, all costs and expenses in connection with administration, management superintendence, small tools, and insurance required by Schedule A of the General Conditions other than Workers' Compensation Insurance; plus

26.2.12 Ten (10%) percent of the total of items in Articles 26.2.1 through 26.2.5, plus the items in Article 26.2.11, as compensation for profit, except that no percentage for profit will be allowed on **Payroll Taxes** or on the premium portion of overtime pay or on sales and personal property taxes; plus

26.2.13 Five (5%) percent of the total of items in Articles 26.2.6 through 26.2.10 as compensation for overhead and profit.

26.3 Where the **Extra Work** is performed in whole or in part by other than the **Contractor's** own forces pursuant to Article 26.2, the **Contractor** shall be paid, subject to pre-audit by the **Engineering Audit Officer**, the cost of such **Work** computed in accordance with Article 26.2 above, plus an additional allowance of five (5%) percent to cover the **Contractor's** overhead and profit.

26.4 Where a change is ordered, involving both **Extra Work** and omitted or reduced **Contract Work**, the **Contract** price shall be adjusted, subject to pre-audit by the **EAO**, in an amount based on the difference between the cost of such **Extra Work** and of the omitted or reduced **Work**.

26.5 Where the **Contractor** and the **Commissioner** can agree upon a fixed price for **Extra Work** in accordance with Article 25.3.2 or another method of payment for **Extra Work** in accordance with

Article 25.3.4, or for **Extra Work** ordered in connection with omitted **Work**, such method, subject to pre-audit by the **EAO**, may, at the option of the **Commissioner**, be substituted for the cost plus a percentage method provided in Article 26.2; provided, however, that if the **Extra Work** is performed by a **Subcontractor**, the **Contractor** shall not be entitled to receive more than an additional allowance of five (5%) percent for overhead and profit over the cost of such **Subcontractor's Work** as computed in accordance with Article 26.2.

## **ARTICLE 27. RESOLUTION OF DISPUTES**

27.1 All disputes between the **City** and the **Contractor** of the kind delineated in this Article 27.1 that arise under, or by virtue of, this **Contract** shall be finally resolved in accordance with the provisions of this Article 27 and the **PPB Rules**. This procedure for resolving all disputes of the kind delineated herein shall be the exclusive means of resolving any such disputes.

27.1.1 This Article 27 shall not apply to disputes concerning matters dealt with in other sections of the **PPB Rules**, or to disputes involving patents, copyrights, trademarks, or trade secrets (as interpreted by the courts of New York State) relating to proprietary rights in computer software.

27.1.2 This Article 27 shall apply only to disputes about the scope of **Work** delineated by the **Contract**, the interpretation of **Contract** documents, the amount to be paid for **Extra Work** or disputed work performed in connection with the **Contract**, the conformity of the **Contractor's Work** to the **Contract**, and the acceptability and quality of the **Contractor's Work**; such disputes arise when the **Engineer, Resident Engineer, Engineering Audit Officer**, or other designee of the **Commissioner** makes a determination with which the **Contractor** disagrees.

27.2 All determinations required by this Article 27 shall be made in writing clearly stated, with a reasoned explanation for the determination based on the information and evidence presented to the party making the determination. Failure to make such determination within the time required by this Article 27 shall be deemed a non-determination without prejudice that will allow application to the next level.

27.3 During such time as any dispute is being presented, heard, and considered pursuant to this Article 27, the **Contract** terms shall remain in force and the **Contractor** shall continue to perform **Work** as directed by the **ACCO** or the **Engineer**. Failure of the **Contractor** to continue **Work** as directed shall constitute a waiver by the **Contractor** of its claim.

27.4 Presentation of Disputes to **Commissioner**.

Notice of Dispute and Agency Response. The **Contractor** shall present its dispute in writing ("Notice of Dispute") to the **Commissioner** within thirty (30) Days of receiving written notice of the determination or action that is the subject of the dispute. This notice requirement shall not be read to replace any other notice requirements contained in the **Contract**. The Notice of Dispute shall include all the facts, evidence, documents, or other basis upon which the **Contractor** relies in support of its position, as well as a detailed computation demonstrating how any amount of money claimed by the **Contractor** in the dispute was arrived at. Within thirty (30) Days after receipt of the detailed written submission comprising the complete Notice of Dispute, the **Engineer, Resident Engineer, Engineering Audit Officer**, or other designee of the **Commissioner** shall submit to the **Commissioner** all materials he or she deems pertinent to the dispute. Following initial submissions to the **Commissioner**, either party may demand of the other the production of any document or other material the demanding party believes may be relevant to the dispute. The requested party shall produce all relevant materials that are not otherwise

protected by a legal privilege recognized by the courts of New York State. Any question of relevancy shall be determined by the **Commissioner** whose decision shall be final. Willful failure of the **Contractor** to produce any requested material whose relevancy the **Contractor** has not disputed, or whose relevancy has been affirmatively determined, shall constitute a waiver by the **Contractor** of its claim.

27.4.1 **Commissioner Inquiry.** The **Commissioner** shall examine the material and may, in his or her discretion, convene an informal conference with the **Contractor**, the **ACCO**, and the **Engineer, Resident Engineer, Engineering Audit Officer**, or other designee of the **Commissioner** to resolve the issue by mutual consent prior to reaching a determination. The **Commissioner** may seek such technical or other expertise as he or she shall deem appropriate, including the use of neutral mediators, and require any such additional material from either or both parties as he or she deems fit. The **Commissioner's** ability to render, and the effect of, a decision hereunder shall not be impaired by any negotiations in connection with the dispute presented, whether or not the **Commissioner** participated therein. The **Commissioner** may or, at the request of any party to the dispute, shall compel the participation of any **Other Contractor** with a contract related to the **Work** of this **Contract**, and that **Contractor** shall be bound by the decision of the **Commissioner**. Any **Other Contractor** thus brought into the dispute resolution proceeding shall have the same rights and obligations under this Article 27 as the **Contractor** initiating the dispute.

27.4.2 **Commissioner Determination.** Within thirty (30) **Days** after the receipt of all materials and information, or such longer time as may be agreed to by the parties, the **Commissioner** shall make his or her determination and shall deliver or send a copy of such determination to the **Contractor**, the **ACCO**, and **Engineer, Resident Engineer, Engineering Audit Officer**, or other designee of the **Commissioner**, as applicable, together with a statement concerning how the decision may be appealed.

27.4.3 **Finality of Commissioner's Decision.** The **Commissioner's** decision shall be final and binding on all parties, unless presented to the Contract Dispute Resolution Board pursuant to this Article 27. The **City** may not take a petition to the Contract Dispute Resolution Board. However, should the **Contractor** take such a petition, the **City** may seek, and the Contract Dispute Resolution Board may render, a determination less favorable to the **Contractor** and more favorable to the **City** than the decision of the **Commissioner**.

27.5 **Presentation of Dispute to the Comptroller.** Before any dispute may be brought by the **Contractor** to the Contract Dispute Resolution Board, the **Contractor** must first present its claim to the **Comptroller** for his or her review, investigation, and possible adjustment.

27.5.1 **Time, Form, and Content of Notice.** Within thirty (30) **Days** of its receipt of a decision by the **Commissioner**, the **Contractor** shall submit to the **Comptroller** and to the **Commissioner** a Notice of Claim regarding its dispute with the **Agency**. The Notice of Claim shall consist of (i) a brief written statement of the substance of the dispute, the amount of money, if any, claimed and the reason(s) the **Contractor** contends the dispute was wrongly decided by the **Commissioner**; (ii) a copy of the written decision of the **Commissioner**; and (iii) a copy of all materials submitted by the **Contractor** to the **Agency**, including the Notice of Dispute. The **Contractor** may not present to the **Comptroller** any material not presented to the **Commissioner**, except at the request of the **Comptroller**.

27.5.2 Response. Within thirty (30) **Days** of receipt of the Notice of Claim, the **Agency** shall make available to the **Comptroller** a copy of all material submitted by the **Agency** to the **Commissioner** in connection with the dispute. The **Agency** may not present to the **Comptroller** any material not presented to the **Commissioner** except at the request of the **Comptroller**.

27.5.3 **Comptroller** Investigation. The **Comptroller** may investigate the claim in dispute and, in the course of such investigation, may exercise all powers provided in Sections 7-201 and 7-203 of the Administrative Code. In addition, the **Comptroller** may demand of either party, and such party shall provide, whatever additional material the **Comptroller** deems pertinent to the claim, including original business records of the **Contractor**. Willful failure of the **Contractor** to produce within fifteen (15) **Days** any material requested by the **Comptroller** shall constitute a waiver by the **Contractor** of its claim. The **Comptroller** may also schedule an informal conference to be attended by the **Contractor**, **Agency** representatives, and any other personnel desired by the **Comptroller**.

27.5.4 Opportunity of **Comptroller** to Compromise or Adjust Claim. The **Comptroller** shall have forty-five (45) **Days** from his or her receipt of all materials referred to in Article 27.5.3 to investigate the disputed claim. The period for investigation and compromise may be further extended by agreement between the **Contractor** and the **Comptroller**, to a maximum of ninety (90) **Days** from the **Comptroller's** receipt of all materials. The **Contractor** may not present its petition to the Contract Dispute Resolution Board until the period for investigation and compromise delineated in this Article 27.5.4 has expired. In compromising or adjusting any claim hereunder, the **Comptroller** may not revise or disregard the terms of the **Contract** between the parties.

27.6 Contract Dispute Resolution Board. There shall be a Contract Dispute Resolution Board composed of:

27.6.1 The chief administrative law judge of the Office of Administrative Trials and Hearings (OATH) or his/her designated OATH administrative law judge, who shall act as chairperson, and may adopt operational procedures and issue such orders consistent with this Article 27 as may be necessary in the execution of the Contract Dispute Resolution Board's functions, including, but not limited to, granting extensions of time to present or respond to submissions;

27.6.2 The **CCPO** or his/her designee; any designee shall have the requisite background to consider and resolve the merits of the dispute and shall not have participated personally and substantially in the particular matter that is the subject of the dispute or report to anyone who so participated; and

27.6.3 A person with appropriate expertise who is not an employee of the **City**. This person shall be selected by the presiding administrative law judge from a prequalified panel of individuals, established and administered by OATH with appropriate background to act as decision-makers in a dispute. Such individual may not have a contract or dispute with the **City** or be an officer or employee of any company or organization that does, or regularly represents persons, companies, or organizations having disputes with the **City**.

27.7 Petition to the Contract Dispute Resolution Board. In the event the claim has not been settled or adjusted by the **Comptroller** within the period provided in this Article 27, the **Contractor**,

within thirty (30) **Days** thereafter, may petition the Contract Dispute Resolution Board to review the **Commissioner's** determination.

27.7.1 **Form and Content of Petition by Contractor.** The **Contractor** shall present its dispute to the Contract Dispute Resolution Board in the form of a petition, which shall include (i) a brief written statement of the substance of the dispute, the amount of money, if any, claimed, and the reason(s) the **Contractor** contends the dispute was wrongly decided by the **Commissioner**; (ii) a copy of the written Decision of the **Commissioner**, (iii) copies of all materials submitted by the **Contractor** to the Agency; (iv) a copy of the written decision of the **Comptroller**, if any, and (v) copies of all correspondence with, or written material submitted by the **Contractor**, to the **Comptroller**. The **Contractor** shall concurrently submit four (4) complete sets of the Petition: one set to the **City Corporation Counsel** (Attn: Commercial and Real Estate Litigation Division) and three (3) sets to the Contract Dispute Resolution Board at OATH's offices with proof of service on the **City Corporation Counsel**. In addition, the **Contractor** shall submit a copy of the written statement of the substance of the dispute, cited in (i) above, to both the **Commissioner** and the **Comptroller**.

27.7.2 **Agency Response.** Within thirty (30) **Days** of its receipt of the Petition by the **City Corporation Counsel**, the **Agency** shall respond to the brief written statement of the **Contractor** and make available to the Contract Dispute Resolution Board all material it submitted to the **Commissioner** and **Comptroller**. Three (3) complete copies of the **Agency** response shall be provided to the Contract Dispute Resolution Board and one to the **Contractor**. Extensions of time for submittal of the **Agency** response shall be given as necessary upon a showing of good cause or, upon consent of the parties, for an initial period of up to thirty (30) **Days**.

27.7.3 **Further Proceedings.** The Contract Dispute Resolution Board shall permit the **Contractor** to present its case by submission of memoranda, briefs, and oral argument. The Contract Dispute Resolution Board shall also permit the **Agency** to present its case in response to the **Contractor** by submission of memoranda, briefs, and oral argument. If requested by the **City Corporation Counsel**, the **Comptroller** shall provide reasonable assistance in the preparation of the **Agency's** case. Neither the **Contractor** nor the **Agency** may support its case with any documentation or other material that was not considered by the **Comptroller**, unless requested by the Contract Dispute Resolution Board. The Contract Dispute Resolution Board, in its discretion, may seek such technical or other expert advice as it shall deem appropriate and may seek, on its own or upon application of a party, any such additional material from any party as it deems fit. The Contract Dispute Resolution Board, in its discretion, may combine more than one dispute between the parties for concurrent resolution.

27.7.4 **Contract Dispute Resolution Board Determination.** Within forty-five (45) **Days** of the conclusion of all written submissions and oral arguments, the Contract Dispute Resolution Board shall render a written decision resolving the dispute. In an unusually complex case, the Contract Dispute Resolution Board may render its decision in a longer period, not to exceed ninety (90) **Days**, and shall so advise the parties at the commencement of this period. The Contract Dispute Resolution Board's decision must be consistent with the terms of the **Contract**. Decisions of the Contract Dispute Resolution Board shall only resolve matters before the Contract Dispute Resolution Board and shall not have precedential effect with respect to matters not before the Contract Dispute Resolution Board.



27.7.5 Notification of Contract Dispute Resolution Board Decision. The Contract Dispute Resolution Board shall send a copy of its decision to the **Contractor**, the **ACCO**, the Engineer, the **Comptroller**, the **City** Corporation Counsel, the **CCPO**, and the **PPB**. A decision in favor of the **Contractor** shall be subject to the prompt payment provisions of the **PPB** Rules. The Required Payment Date shall be thirty (30) Days after the date the parties are formally notified of the Contract Dispute Resolution Board's decision.

27.7.6 Finality of Contract Dispute Resolution Board Decision. The Contract Dispute Resolution Board's decision shall be final and binding on all parties. Any party may seek review of the Contract Dispute Resolution Board's decision solely in the form of a challenge, filed within four (4) months of the date of the Contract Dispute Resolution Board's decision, in a court of competent jurisdiction of the State of New York, County of New York pursuant to Article 78 of the Civil Practice Law and Rules. Such review by the court shall be limited to the question of whether or not the Contract Dispute Resolution Board's decision was made in violation of lawful procedure, was affected by an error of **Law**, or was arbitrary and capricious or an abuse of discretion. No evidence or information shall be introduced or relied upon in such proceeding that was not presented to the Contract Dispute Resolution Board in accordance with this Article 27.

27.8 Any termination, cancellation, or alleged breach of the **Contract** prior to or during the pendency of any proceedings pursuant to this Article 27 shall not affect or impair the ability of the **Commissioner** or Contract Dispute Resolution Board to make a binding and final decision pursuant to this Article 27.

## **ARTICLE 28. RECORD KEEPING FOR EXTRA OR DISPUTED WORK OR WORK ON A TIME & MATERIALS BASIS**

28.1 While the **Contractor** or any of its **Subcontractors** is performing **Work** on a time and material basis or **Extra Work** on a time and material basis ordered by the **Commissioner** under Article 25, or where the **Contractor** believes that it or any of its **Subcontractors** is performing **Extra Work** but a final determination by **Agency** has not been made, or the **Contractor** or any of its **Subcontractors** is performing disputed **Work** (whether on or off the **Site**), or complying with a determination or order under protest in accordance with Articles 11, 27, and 30, in each such case the **Contractor** shall furnish the **Resident Engineer** daily with three (3) copies of written statements signed by the **Contractor's** representative at the **Site** showing:

28.1.1 The name, trade, and number of each worker employed on such **Work** or engaged in complying with such determination or order, the number of hours employed, and the character of the **Work** each is doing; and

28.1.2 The nature and quantity of any materials, plant and equipment furnished or used in connection with the performance of such **Work** or compliance with such determination or order, and from whom purchased or rented.

28.2 A copy of such statement will be countersigned by the **Resident Engineer**, noting thereon any items not agreed to or questioned, and will be returned to the **Contractor** within two (2) **Days** after submission.

28.3 The **Contractor** and its **Subcontractors**, when required by the **Commissioner**, or the **Comptroller**, shall also produce for inspection, at the office of the **Contractor** or **Subcontractor**, any and all of its books, bid documents, financial statements, vouchers, records, daily job diaries and reports,

and cancelled checks, and any other documents relating to showing the nature and quantity of the labor, materials, plant and equipment actually used in the performance of such **Work**, or in complying with such determination or order, and the amounts expended therefor, and shall permit the **Commissioner** and the **Comptroller** to make such extracts therefrom, or copies thereof, as they or either of them may desire.

28.4 In connection with the examination provided for herein, the **Commissioner**, upon demand therefor, will produce for inspection by the **Contractor** such records as the **Agency** may have with respect to such **Extra Work** or disputed **Work** performed under protest pursuant to order of the **Commissioner**, except those records and reports which may have been prepared for the purpose of determining the accuracy and validity of the **Contractor's** claim.

28.5 Failure to comply strictly with these requirements shall constitute a waiver of any claim for extra compensation or damages on account of the performance of such **Work** or compliance with such determination or order.

### **ARTICLE 29. OMITTED WORK**

29.1 If any **Contract Work** in a lump sum **Contract**, or if any part of a lump sum item in a unit price, lump sum, or percentage-bid **Contract** is omitted by the **Commissioner** pursuant to Article 33, the **Contract** price, subject to audit by the EAO, shall be reduced by a pro rata portion of the lump sum bid amount based upon the percent of **Work** omitted subject to Article 29.4. For the purpose of determining the pro rata portion of the lump sum bid amount, the bid breakdown submitted in accordance with Article 41 shall be considered, but shall not be the determining factor.

29.2 If the whole of a lump sum item or units of any other item is so omitted by the **Commissioner** in a unit price, lump sum, or percentage-bid **Contract**, then no payment will be made therefor except as provided in Article 29.4.

29.3 For units that have been ordered but are only partially completed, the unit price shall be reduced by a pro rata portion of the unit price bid based upon the percentage of **Work** omitted subject to Article 29.4.

29.4 In the event the **Contractor**, with respect to any omitted **Work**, has purchased any non-cancelable material and/or equipment that is not capable of use except in the performance of this **Contract** and has been specifically fabricated for the sole purpose of this **Contract**, but not yet incorporated into the **Work**, the **Contractor** shall be paid for such material and/or equipment in accordance with Article 64.2.1(b); provided, however, such payment is contingent upon the **Contractor's** delivery of such material and/or equipment in acceptable condition to a location designated by the **City**.

29.5 The **Contractor** agrees to make no claim for damages or for loss of overhead and profit with regard to any omitted **Work**.

### **ARTICLE 30. NOTICE AND DOCUMENTATION OF COSTS AND DAMAGES; PRODUCTION OF FINANCIAL RECORDS**

30.1 If the **Contractor** shall claim to be sustaining damages by reason of any act or omission of the **City** or its agents, it shall submit to the **Commissioner** within forty-five (45) **Days** from the time such damages are first incurred, and every thirty (30) **Days** thereafter to the extent additional damages are being incurred for the same condition, verified statements of the details and the amounts of such

damages, together with documentary evidence of such damages. The **Contractor** may submit any of the above statements within such additional time as may be granted by the **Commissioner** in writing upon written request therefor. Failure of the **Commissioner** to respond in writing to a written request for additional time within thirty (30) **Days** shall be deemed a denial of the request. On failure of the **Contractor** to strictly comply with the foregoing provisions, such claims shall be deemed waived and no right to recover on such claims shall exist. Damages that the **Contractor** may claim in any action or dispute resolution procedure arising under or by reason of this **Contract** shall not be different from or in excess of the statements and documentation made pursuant to this Article 30. This Article 30.1 does not apply to claims submitted to the **Commissioner** pursuant to Article 11 or to claims disputing a determination under Article 27.

30.2 In addition to the foregoing statements, the **Contractor** shall, upon notice from the **Commissioner**, produce for examination at the **Contractor's** office, by the **Engineer, Architect or Project Manager**, all of its books of account, bills, invoices, payrolls, subcontracts, time books, daily reports, bank deposit books, bank statements, check books, and cancelled checks, showing all of its acts and transactions in connection with or relating to or arising by reason of this **Contract**, and submit itself and persons in its employment, for examination under oath by any person designated by the **Commissioner** or **Comptroller** to investigate claims made or disputes against the **City** under this **Contract**. At such examination, a duly authorized representative of the **Contractor** may be present.

30.3 In addition to the statements required under Article 28 and this Article 30, the **Contractor** and/or its **Subcontractor** shall, within thirty (30) **Days** upon notice from the **Commissioner** or **Comptroller**, produce for examination at the **Contractor's** and/or **Subcontractor's** office, by a representative of either the **Commissioner** or **Comptroller**, all of its books of account, bid documents, financial statements, accountant workpapers, bills, invoices, payrolls, subcontracts, time books, daily reports, bank deposit books, bank statements, check books, and cancelled checks, showing all of its acts and transactions in connection with or relating to or arising by reason of this **Contract**. Further, the **Contractor** and/or its **Subcontractor** shall submit any person in its employment, for examination under oath by any person designated by the **Commissioner** or **Comptroller** to investigate claims made or disputes against the **City** under this **Contract**. At such examination, a duly authorized representative of the **Contractor** may be present.

30.4 Unless the information and examination required under Article 30.3 is provided by the **Contractor** and/or its **Subcontractor** upon thirty (30) **Days'** notice from the **Commissioner** or **Comptroller**, or upon the **Commissioner's** or **Comptroller's** written authorization to extend the time to comply, the **City** shall be released from all claims arising under, relating to or by reason of this **Contract**, except for sums certified by the **Commissioner** to be due under the provisions of this **Contract**. It is further stipulated and agreed that no person has the power to waive any of the foregoing provisions and that in any action or dispute resolution procedure against the **City** to recover any sum in excess of the sums certified by the **Commissioner** to be due under or by reason of this **Contract**, the **Contractor** must allege in its complaint and prove, at trial or during such dispute resolution procedure, compliance with the provisions of this Article 30.

30.5 In addition, after the commencement of any action or dispute resolution procedure by the **Contractor** arising under or by reason of this **Contract**, the **City** shall have the right to require the **Contractor** to produce for examination under oath, up until the trial of the action or hearing before the Contract Dispute Resolution Board, the books and documents described in Article 30.3 and submit itself and all persons in its employ for examination under oath. If this Article 30 is not complied with as required, then the **Contractor** hereby consents to the dismissal of the action or dispute resolution procedure.

**CHAPTER VII: POWERS OF THE RESIDENT ENGINEER, THE ENGINEER OR ARCHITECT AND THE COMMISSIONER**

**ARTICLE 31. THE RESIDENT ENGINEER**

31.1 The **Resident Engineer** shall have the power to inspect, supervise, and control the performance of the **Work**, subject to review by the **Commissioner**. The **Resident Engineer** shall not, however, have the power to issue an **Extra Work** order, except as specifically designated in writing by the **Commissioner**.

**ARTICLE 32. THE ENGINEER OR ARCHITECT OR PROJECT MANAGER**

32.1 The **Engineer** or **Architect** or **Project Manager**, in addition to those matters elsewhere herein delegated to the **Engineer** and expressly made subject to his/her determination, direction or approval, shall have the power, subject to review by the **Commissioner**:

32.1.1 To determine the amount, quality, and location of the **Work** to be paid for hereunder; and

32.1.2 To determine all questions in relation to the **Work**, to interpret the **Contract Drawings, Specifications, and Addenda**, and to resolve all patent inconsistencies or ambiguities therein; and

32.1.3 To determine how the **Work** of this **Contract** shall be coordinated with **Work** of **Other Contractors** engaged simultaneously on this **Project**, including the power to suspend any part of the **Work**, but not the whole thereof; and

32.1.4 To make minor changes in the **Work** as he/she deems necessary, provided such changes do not result in a net change in the cost to the **City** or to the **Contractor** of the **Work** to be done under the **Contract**; and

32.1.5 To amplify the **Contract Drawings**, add explanatory information and furnish additional **Specifications** and drawings, consistent with this **Contract**.

32.2 The foregoing enumeration shall not imply any limitation upon the power of the **Engineer** or **Architect** or **Project Manager**, for it is the intent of this **Contract** that all of the **Work** shall generally be subject to his/her determination, direction, and approval, except where the determination, direction or approval of someone other than the **Engineer** or **Architect** or **Project Manager** is expressly called for herein.

32.3 The **Engineer** or **Architect** or **Project Manager** shall not, however, have the power to issue an **Extra Work** order, except as specifically designated in writing by the **Commissioner**.

**ARTICLE 33. THE COMMISSIONER**

33.1 The **Commissioner**, in addition to those matters elsewhere herein expressly made subject to his/her determination, direction or approval, shall have the power:

33.1.1 To review and make determinations on any and all questions in relation to this **Contract** and its performance; and

33.1.2 To modify or change this **Contract** so as to require the performance of **Extra Work** (subject, however, to the limitations specified in Article 25) or the omission of **Contract Work**; and

33.1.3 To suspend the whole or any part of the **Work** whenever in his/her judgment such suspension is required:

33.1.3(a) In the interest of the **City** generally; or

33.1.3(b) To coordinate the **Work** of the various contractors engaged on this **Project** pursuant to the provisions of Article 12; or

33.1.3(c) To expedite the completion of the entire **Project** even though the completion of this particular **Contract** may thereby be delayed.

#### **ARTICLE 34. NO ESTOPPEL**

34.1 Neither the **City** nor any **Agency**, official, agent or employee thereof, shall be bound, precluded or estopped by any determination, decision, approval, order, letter, payment or certificate made or given under or in connection with this **Contract** by the **City**, the **Commissioner**, the **Engineer**, the **Resident Engineer**, or any other official, agent or employee of the **City**, either before or after the final completion and acceptance of the **Work** and payment therefor:

34.1.1 From showing the true and correct classification, amount, quality or character of the **Work** actually done; or that any such determination, decision, order, letter, payment or certificate was untrue, incorrect or improperly made in any particular, or that the **Work**, or any part thereof, does not in fact conform to the requirements of this **Contract**; and

34.1.2 From demanding and recovering from the **Contractor** any overpayment made to it, or such damages as the **City** may sustain by reason of the **Contractor's** failure to perform each and every part of its **Contract**.

### **CHAPTER VIII: LABOR PROVISIONS**

#### **ARTICLE 35. EMPLOYEES**

35.1 The **Contractor** and its **Subcontractors** shall not employ on the **Work**:

35.1.1 Anyone who is not competent, faithful and skilled in the **Work** for which he/she shall be employed; and whenever the **Commissioner** shall inform the **Contractor**, in writing, that any employee is, in his/her opinion, incompetent, unfaithful or disobedient, that employee shall be discharged from the **Work** forthwith, and shall not again be employed upon it; or

35.1.2 Any labor, materials or means whose employment, or utilization during the course of this **Contract**, may tend to or in any way cause or result in strikes, work stoppages, delays, suspension of **Work** or similar troubles by workers employed by the **Contractor** or its **Subcontractors**, or by any of the trades working in or about the buildings and premises where **Work** is being performed under this **Contract**, or by **Other Contractors** or their **Subcontractors** pursuant to other contracts, or on any other building or premises owned or operated by the **City**, its **Agencies**, departments, boards or authorities. Any violation by the **Contractor** of this requirement may, upon certification of the **Commissioner**, be considered as proper and sufficient cause for declaring the **Contractor** to be in default, and for the **City** to take action against it as set forth in Chapter X of this **Contract**, or such other article of this **Contract** as the Commissioner may deem proper; or

35.1.3 In accordance with Section 220.3-e of the Labor Law of the State of New York (hereinafter "Labor Law"), the **Contractor** and its **Subcontractors** shall not employ on the **Work** any apprentice, unless he/she is a registered individual, under a bona fide program registered with the New York State Department of Labor. The allowable ratio of apprentices to journey-level workers in any craft classification shall not be greater than the ratio permitted to the **Contractor** as to its work force on any job under the registered program. Any employee listed on a payroll at an apprentice wage rate, who is not registered as above, shall be paid the wage rate determined by the **Comptroller** of the **City** for the classification of **Work** actually performed. The **Contractor** or **Subcontractor** will be required to furnish written evidence of the registration of its program and apprentices as well as all the appropriate ratios and wage rates, for the area of the construction prior to using any apprentices on the **Contract Work**.

35.2 If the total cost of the **Work** under this **Contract** is at least two hundred fifty thousand (\$250,000) dollars, all laborers, workers, and mechanics employed in the performance of the **Contract** on the public work site, either by the **Contractor**, **Subcontractor** or other person doing or contracting to do the whole or a part of the **Work** contemplated by the **Contract**, shall be certified prior to performing any **Work** as having successfully completed a course in construction safety and health approved by the United States Department of Labor's Occupational Safety and Health Administration that is at least ten (10) hours in duration.

35.3 In accordance with Local Law Nos. 30-2012 and 33-2012, codified at sections 6-132 and 12-113 of the Administrative Code, respectively,

35.3.1 The **Contractor** shall not take an adverse personnel action with respect to an officer or employee in retaliation for such officer or employee making a report of information concerning conduct which such officer or employee knows or reasonably believes to involve corruption, criminal activity, conflict of interest, gross mismanagement or abuse of authority by any officer or employee relating to this **Contract** to (a) the Commissioner of the Department of Investigation, (b) a member of the New York City Council, the Public Advocate, or the **Comptroller**, or (c) the **CCPO**, **ACCO**, **Agency** head, or **Commissioner**.

35.3.2 If any of the **Contractor**'s officers or employees believes that he or she has been the subject of an adverse personnel action in violation of Article 35.3.1, he or she shall be entitled to bring a cause of action against the **Contractor** to recover all relief necessary to make him or her whole. Such relief may include but is not limited to: (a) an injunction to restrain continued retaliation, (b) reinstatement to the position such employee would have had but for the retaliation or to an equivalent position, (c) reinstatement of full fringe benefits and seniority rights, (d) payment of two times back

pay, plus interest, and (e) compensation for any special damages sustained as a result of the retaliation, including litigation costs and reasonable attorney's fees.

35.3.3 The **Contractor** shall post a notice provided by the **City** in a prominent and accessible place on any site where work pursuant to the **Contract** is performed that contains information about:

35.3.3(a) how its employees can report to the New York City Department of Investigation allegations of fraud, false claims, criminality or corruption arising out of or in connection with the **Contract**; and

35.3.3(b) the rights and remedies afforded to its employees under Administrative Code sections 7-805 (the New York City False Claims Act) and 12-113 (the Whistleblower Protection Expansion Act) for lawful acts taken in connection with the reporting of allegations of fraud, false claims, criminality or corruption in connection with the **Contract**.

35.3.4 For the purposes of this Article 35.3, "adverse personnel action" includes dismissal, demotion, suspension, disciplinary action, negative performance evaluation, any action resulting in loss of staff, office space, equipment or other benefit, failure to appoint, failure to promote, or any transfer or assignment or failure to transfer or assign against the wishes of the affected officer or employee.

35.3.5 This Article 35.3 is applicable to all of the **Contractor's Subcontractors** having subcontracts with a value in excess of \$100,000; accordingly, the **Contractor** shall include this rider in all subcontracts with a value a value in excess of \$100,000.

35.4 Article 35.3 is not applicable to this **Contract** if it is valued at \$100,000 or less. Articles 35.3.1, 35.3.2, 35.3.4, and 35.3.5 are not applicable to this **Contract** if it was solicited pursuant to a finding of an emergency.

## 35.5 Paid Sick Leave Law.

### 35.5.1 Introduction and General Provisions.

35.5.1(a) The Earned Sick Time Act, also known as the Paid Sick Leave Law ("PSLL"), requires covered employees who annually perform more than 80 hours of work in New York City to be provided with paid sick time.<sup>2</sup> Contractors of the **City** or of other governmental entities may be required to provide sick time pursuant to the PSLL.

35.5.1(b) The PSLL became effective on April 1, 2014, and is codified at Title 20, Chapter 8, of the New York City Administrative Code. It is administered by the City's Department of Consumer Affairs ("DCA"); DCA's rules promulgated under the PSLL are codified at Chapter 7 of Title 6 of the Rules of the City of New York ("Rules").

---

<sup>2</sup> Pursuant to the PSLL, if fewer than five employees work for the same employer, as determined pursuant to New York City Administrative Code § 20-912(g), such employer has the option of providing such employees uncompensated sick time.

35.5.1(c) The **Contractor** agrees to comply in all respects with the PSL and the Rules, and as amended, if applicable, in the performance of this **Contract**. The **Contractor** further acknowledges that such compliance is a material term of this **Contract** and that failure to comply with the PSL in performance of this **Contract** may result in its termination.

35.5.1(d) The **Contractor** must notify the **Agency Chief Contracting Officer** of the **Agency** with whom it is contracting in writing within ten (10) days of receipt of a complaint (whether oral or written) regarding the PSL involving the performance of this **Contract**. Additionally, the **Contractor** must cooperate with DCA's education efforts and must comply with DCA's subpoenas and other document demands as set forth in the PSL and Rules.

35.5.1(e) The PSL is summarized below for the convenience of the **Contractor**. The **Contractor** is advised to review the PSL and Rules in their entirety. On the website [www.nyc.gov/PaidSickLeave](http://www.nyc.gov/PaidSickLeave) there are links to the PSL and the associated Rules as well as additional resources for employers, such as Frequently Asked Questions, timekeeping tools and model forms, and an event calendar of upcoming presentations and webinars at which the **Contractor** can get more information about how to comply with the PSL. The **Contractor** acknowledges that it is responsible for compliance with the PSL notwithstanding any inconsistent language contained herein.

#### 35.5.2 Pursuant to the PSL and the Rules: Applicability, Accrual, and Use.

35.5.2(a) An employee who works within the City of New York for more than eighty hours in any consecutive 12-month period designated by the employer as its "calendar year" pursuant to the PSL ("Year") must be provided sick time. Employers must provide a minimum of one hour of sick time for every 30 hours worked by an employee and compensation for such sick time must be provided at the greater of the employee's regular hourly rate or the minimum wage. Employers are not required to provide more than 40 hours of sick time to an employee in any Year.

35.5.2(b) An employee has the right to determine how much sick time he or she will use, provided that employers may set a reasonable minimum increment for the use of sick time not to exceed four hours per **Day**. In addition, an employee may carry over up to 40 hours of unused sick time to the following Year, provided that no employer is required to allow the use of more than forty hours of sick time in a Year or carry over unused paid sick time if the employee is paid for such unused sick time and the employer provides the employee with at least the legally required amount of paid sick time for such employee for the immediately subsequent Year on the first **Day** of such Year.

35.5.2(c) An employee entitled to sick time pursuant to the PSL may use sick time for any of the following:

- i. such employee's mental illness, physical illness, injury, or health condition or the care of such illness, injury, or condition or such employee's need for medical diagnosis or preventive medical care;
- ii. such employee's care of a family member (an employee's child, spouse, domestic partner, parent, sibling, grandchild or grandparent, or the child or parent of an employee's spouse or domestic partner) who has a mental



- illness, physical illness, injury or health condition or who has a need for medical diagnosis or preventive medical care;
- iii. closure of such employee's place of business by order of a public official due to a public health emergency; or
  - iv. such employee's need to care for a child whose school or childcare provider has been closed due to a public health emergency.

35.5.2(d) An employer must not require an employee, as a condition of taking sick time, to search for a replacement. However, an employer may require an employee to provide: reasonable notice of the need to use sick time; reasonable documentation that the use of sick time was needed for a reason above if for an absence of more than three consecutive work days; and/or written confirmation that an employee used sick time pursuant to the PSL. However, an employer may not require documentation specifying the nature of a medical condition or otherwise require disclosure of the details of a medical condition as a condition of providing sick time and health information obtained solely due to an employee's use of sick time pursuant to the PSL must be treated by the employer as confidential.

35.5.2(e) If an employer chooses to impose any permissible discretionary requirement as a condition of using sick time, it must provide to all employees a written policy containing those requirements, using a delivery method that reasonably ensures that employees receive the policy. If such employer has not provided its written policy, it may not deny sick time to an employee because of non-compliance with such a policy.

35.5.2(f) Sick time to which an employee is entitled must be paid no later than the payday for the next regular payroll period beginning after the sick time was used.

35.5.3 Exemptions and Exceptions. Notwithstanding the above, the PSL does not apply to any of the following:

35.5.3(a) an independent contractor who does not meet the definition of employee under section 190(2) of the New York State Labor Law;

35.5.3(b) an employee covered by a valid collective bargaining agreement in effect on April 1, 2014, until the termination of such agreement;

35.5.3(c) an employee in the construction or grocery industry covered by a valid collective bargaining agreement if the provisions of the PSL are expressly waived in such collective bargaining agreement;

35.5.3(d) an employee covered by another valid collective bargaining agreement if such provisions are expressly waived in such agreement and such agreement provides a benefit comparable to that provided by the PSL for such employee;

35.5.3(e) an audiologist, occupational therapist, physical therapist, or speech language pathologist who is licensed by the New York State Department of Education and who calls in for work assignments at will, determines his or her own schedule, has the ability to reject or accept any assignment referred to him or her, and is paid an average hourly wage that is at least four times the federal minimum wage;

35.5.3(f) an employee in a work study program under Section 2753 of Chapter 42 of the United States Code;

35.5.3(g) an employee whose work is compensated by a qualified scholarship program as that term is defined in the Internal Revenue Code, Section 117 of Chapter 20 of the United States Code; or

35.5.3(h) a participant in a Work Experience Program (WEP) under section 336-c of the New York State Social Services Law.

35.5.4 Retaliation Prohibited. An employer may not threaten or engage in retaliation against an employee for exercising or attempting in good faith to exercise any right provided by the PSL. In addition, an employer may not interfere with any investigation, proceeding, or hearing pursuant to the PSL.

35.5.5 Notice of Rights.

35.5.5(a) An employer must provide its employees with written notice of their rights pursuant to the PSL. Such notice must be in English and the primary language spoken by an employee, provided that DCA has made available a translation into such language. Downloadable notices are available on DCA's website at <http://www.nyc.gov/html/dca/html/law/PaidSickLeave.shtml>.

35.5.5(b) Any person or entity that willfully violates these notice requirements is subject to a civil penalty in an amount not to exceed fifty dollars for each employee who was not given appropriate notice.

35.5.6 Records. An employer must retain records documenting its compliance with the PSL for a period of at least three years, and must allow DCA to access such records in furtherance of an investigation related to an alleged violation of the PSL.

35.5.7 Enforcement and Penalties.

35.5.7(a) Upon receiving a complaint alleging a violation of the PSL, DCA has the right to investigate such complaint and attempt to resolve it through mediation. Within **30 Days** of written notification of a complaint by DCA, or sooner in certain circumstances, the employer must provide DCA with a written response and such other information as DCA may request. If DCA believes that a violation of the PSL has occurred, it has the right to issue a notice of violation to the employer.

35.5.7(b) DCA has the power to grant an employee or former employee all appropriate relief as set forth in New York City Administrative Code § 20-924(d). Such relief may include, among other remedies, treble damages for the wages that should have been paid, damages for unlawful retaliation, and damages and reinstatement for unlawful discharge. In addition, DCA may impose on an employer found to have violated the PSL civil penalties not to exceed \$500 for a first violation, \$750 for a second violation within two years of the first violation, and \$1,000 for each succeeding violation within two years of the previous violation.

35.5.8 More Generous Policies and Other Legal Requirements. Nothing in the PSL is intended to discourage, prohibit, diminish, or impair the adoption or retention of a more generous sick time policy, or the obligation of an employer to comply with any contract,

collective bargaining agreement, employment benefit plan or other agreement providing more generous sick time. The PSLL provides minimum requirements pertaining to sick time and does not preempt, limit or otherwise affect the applicability of any other law, regulation, rule, requirement, policy or standard that provides for greater accrual or use by employees of sick leave or time, whether paid or unpaid, or that extends other protections to employees. The PSLL may not be construed as creating or imposing any requirement in conflict with any federal or state law, rule or regulation.

35.6 HireNYC: Hiring and Reporting Requirements. This Article 35.6 applies to construction contracts of \$1,000,000 or more. The **Contractor** shall comply with the requirements of Articles 35.6.1-35.6.5 for all non-trades jobs (e.g., for an administrative position arising out of **Work** ant located in New York City). The **Contractor** shall reasonably cooperate with SBS and the **City** on specific outreach events, including “Hire-on-the-Spot” events, for the hiring of trades workers in connection with the **Work**. If provided elsewhere in this **Contract**, this **Contract** is subject to a project labor agreement.

35.6.1 Enrollment. The **Contractor** shall enroll with the HireNYC system, found at [www.nyc.gov/sbs](http://www.nyc.gov/sbs), within thirty (30) days after the registration of this **Contract** pursuant to Section 328 of the New York City Charter. The **Contractor** shall provide information about the business, designate a primary contact and say whether it intends to hire for any entry to mid-level job opportunities arising from this **Contract** and located in New York City, and, if so, the approximate start date of the first hire.

35.6.2 Job Posting Requirements.

35.6.2(a) Once enrolled in HireNYC, the **Contractor** agrees to update the HireNYC portal with all entry to mid-level job opportunities arising from this **Contract** and located in New York City, if any, which shall be defined as jobs requiring no more than an associate degree, as provided by the New York State Department of Labor (see Column F of <https://labor.ny.gov/stats/2012-2022-NYS-Employment-Prospects.xls>). The information to be updated includes the types of entry and mid-level positions made available from the work arising from the **Contract** and located in New York City, the number of positions, the anticipated schedule of initiating the hiring process for these positions, and the contact information for the **Contractor’s** representative charged with overseeing hiring. The **Contractor** must update the HireNYC portal with any hiring needs arising from the contract and located in New York City, and the requirements of the jobs to be filled, no less than three weeks prior to the intended first day of employment for each new position, except with the permission of SBS, not to be unreasonably withheld, and must also update the HireNYC portal as set forth below.

35.6.2(b) After enrollment through HireNYC and submission of relevant information, SBS will work with the **Contractor** to develop a recruitment plan which will outline the candidate screening process, and will provide clear instructions as to when, where, and how interviews will take place. HireNYC will screen applicants based on employer requirements and refer applicants whom it believes are qualified to the **Contractor** for interviews. The **Contractor** must interview referred applicants whom it believes are qualified.

35.6.2(c) After completing an interview of a candidate referred by HireNYC, the **Contractor** must provide feedback via the portal within twenty (20) business days to indicate which candidates were interviewed and hired, if any. In addition, the **Contractor** shall provide the start date of new hires, and additional information

reasonably related to such hires, within twenty (20) business days after the start date. In the event the **Contractor** does not have any job openings covered by this Rider in any given year, the **Contractor** shall be required to provide an annual update to HireNYC to that effect. For this purpose, the reporting year shall run from the date of the registration of the **Contract** pursuant to Charter section 328 and each anniversary date.

35.6.2(d) These requirements do not limit the **Contractor's** ability to assess the qualifications of prospective workers, and to make final hiring and retention decisions. No provision of this Article 35.6 shall be interpreted so as to require the **Contractor** to employ any particular worker.

35.6.2(e) In addition, the provisions of this Article 35.6 shall not apply to positions that the **Contractor** intends to fill with employees employed pursuant to the job retention provision of Section 22-505 of the Administrative Code of the City of New York. The **Contractor** shall not be required to report such openings with HireNYC. However, the **Contractor** shall enroll with the HireNYC system pursuant to Article 35.6.1, above, and, if such positions subsequently become open, then the remaining provisions of this Article 35.6 will apply.

35.6.3 Breach and Liquidated Damages. If the **Contractor** fails to comply with the terms of the **Contract** and this Article 35.6 (1) by not enrolling its business with HireNYC; (2) by not informing HireNYC, as required, of open positions; or (3) by failing to interview a qualified candidate, the **Agency** may assess liquidated damages in the amount of two-thousand five hundred dollars (\$2,500) per breach. For all other events of noncompliance with the terms of this Article 35.6, the **Agency** may assess liquidated damages in the amount of five hundred dollars (\$500) per breach. Furthermore, in the event the **Contractor** breaches the requirements of this Article 35.6 during the term of the **Contract**, the **City** may hold the **Contractor** in default of this **Contract**.

35.6.4 Audit Compliance. In addition to the auditing requirements set forth in other parts of the **Contract**, the **Contractor** shall permit SBS and the **City** to inspect any and all records concerning or relating to job openings or the hiring of individuals for work arising from the **Contract** and located in New York City. The **Contractor** shall permit an inspection within seven (7) business days of the request.

35.6.5 Other Reporting Requirements. The **Contractor** shall report to the **City**, on a monthly basis, all information reasonably requested by the **City** that is necessary for the **City** to comply with any reporting requirements imposed by **Law**, including any requirement that the **City** maintain a publicly accessible database. In addition, the **Contractor** agrees to comply with all reporting requirements imposed by **Law**, or as otherwise requested by the **City**.

35.6.6 Federal Hiring Requirements. If this **Contract** is federally funded (as indicated elsewhere in this **Contract**), the **Contractor** shall comply with all federal hiring requirements as may be set forth in this **Contract**, including, as applicable: (a) Section 3 of the HUD Act of 1968, which requires, to the greatest extent feasible, economic opportunities for 30 percent of new hires be given to low- and very low-income persons, particularly persons who are recipients of HUD assistance for housing and Executive Order 11246, which prohibits discrimination in employment due to race, color, religion, sex or national origin, and requires the implementation of goals for minority and female participation for work involving any construction trade.

## ARTICLE 36. NO DISCRIMINATION

36.1 The **Contractor** specifically agrees, as required by Labor Law Section 220-e, as amended, that:

36.1.1 In the hiring of employees for the performance of **Work** under this **Contract** or any subcontract hereunder, neither the **Contractor**, **Subcontractor**, nor any person acting on behalf of such **Contractor** or **Subcontractor**, shall by reason of race, creed, color or national origin discriminate against any citizen of the State of New York who is qualified and available to perform the **Work** to which the employment relates;

36.1.2 Neither the **Contractor**, **Subcontractor**, nor any person on its behalf shall, in any manner, discriminate against or intimidate any employee hired for the performance of **Work** under this **Contract** on account of race, creed, color or national origin;

36.1.3 There may be deducted from the amount payable to the **Contractor** by the **City** under this **Contract** a penalty of fifty (\$50.00) dollars for each person for each **Day** during which such person was discriminated against or intimidated in violation of the provisions of this **Contract**; and

36.1.4 This **Contract** may be cancelled or terminated by the **City** and all moneys due or to become due hereunder may be forfeited, for a second or any subsequent violation of the terms or conditions of this Article 36.

36.1.5 This Article 36 covers all construction, alteration and repair of any public building or public work occurring in the State of New York and the manufacture, sale, and distribution of materials, equipment, and supplies to the extent that such operations are performed within the State of New York pursuant to this **Contract**.

36.2 The **Contractor** specifically agrees, as required by Section 6-108 of the Administrative Code, as amended, that:

36.2.1 It shall be unlawful for any person engaged in the construction, alteration or repair of buildings or engaged in the construction or repair of streets or highways pursuant to a **Contract** with the **City** or engaged in the manufacture, sale or distribution of materials, equipment or supplies pursuant to a **Contract** with the **City** to refuse to employ or to refuse to continue in any employment any person on account of the race, color or creed of such person.

36.2.2 It shall be unlawful for any person or any servant, agent or employee of any person, described in Article 36.1.2, to ask, indicate or transmit, orally or in writing, directly or indirectly, the race, color or creed or religious affiliation of any person employed or seeking employment from such person, firm or corporation.

36.2.3 Breach of the foregoing provisions shall be deemed a violation of a material provision of this **Contract**.

36.2.4 Any person, or the employee, manager or owner of or officer of such firm or corporation who shall violate any of the provisions of this Article 36.2 shall, upon

conviction thereof, be punished by a fine of not more than one hundred (\$100.00) dollars or by imprisonment for not more than thirty (30) **Days**, or both.

36.3 This **Contract** is subject to the requirements of Executive Order No. 50 (1980) (“E.O. 50”), as revised, and the rules and regulations promulgated thereunder. No contract will be awarded unless and until these requirements have been complied with in their entirety. By signing this **Contract**, the **Contractor** agrees that it:

36.3.1 Will not engage in any unlawful discrimination against any employee or applicant for employment because of race, creed, color, national origin, sex, age, disability, marital status or sexual orientation with respect to all employment decisions including, but not limited to, recruitment, hiring, upgrading, demotion, downgrading, transfer, training, rates of pay or other forms of compensation, layoff, termination, and all other terms and conditions of employment; and

36.3.2 Will not engage in any unlawful discrimination in the selection of **Subcontractors** on the basis of the owner’s race, color, creed, national origin, sex, age, disability, marital status or sexual orientation; and

36.3.3 Will state in all solicitations or advertisements for employees placed by or on behalf of the **Contractor** that all qualified applicants will receive consideration for employment without unlawful discrimination based on race, creed, color, national origin, sex, age, citizens status, disability, marital status, sexual orientation, or that it is an equal employment opportunity employer; and

36.3.4 Will send to each labor organization or representative of workers with which it has a collective bargaining agreement or other contract or memorandum of understanding, written notification of its equal employment opportunity commitments under E.O. 50 and the rules and regulations promulgated thereunder; and

36.3.5 Will furnish, before the award of the **Contract**, all information and reports, including an employment report, that are required by E.O. 50, the rules and regulations promulgated thereunder, and orders of the **City** Department of Business Services, Division of Labor Services (**DLS**) and will permit access to its books, records, and accounts by the **DLS** for the purposes of investigation to ascertain compliance with such rules, regulations, and orders.

36.4 The **Contractor** understands that in the event of its noncompliance with the nondiscrimination clauses of this **Contract** or with any of such rules, regulations, or orders, such noncompliance shall constitute a material breach of this **Contract** and noncompliance with E.O. 50 and the rules and regulations promulgated thereunder. After a hearing held pursuant to the rules of the **DLS**, the Director of the **DLS** may direct the **Commissioner** to impose any or all of the following sanctions:

36.4.1 Disapproval of the **Contractor**; and/or

36.4.2 Suspension or termination of the **Contract**; and/or

36.4.3 Declaring the **Contractor** in default; and/or

36.4.4 In lieu of any of the foregoing sanctions, the Director of the **DLS** may impose an employment program.

In addition to any actions taken under this **Contract**, failure to comply with E.O. 50 and the rules and regulations promulgated thereunder, in one or more instances, may result in a **City Agency** declaring the **Contractor** to be non-responsible in future procurements. The **Contractor** further agrees that it will refrain from entering into any **Contract** or **Contract** modification subject to E.O. 50 and the rules and regulations promulgated thereunder with a **Subcontractor** who is not in compliance with the requirements of E.O. 50 and the rules and regulations promulgated thereunder.

36.5 The **Contractor** specifically agrees, as required by Section 6-123 of the Administrative Code, that:

36.5.1 The **Contractor** will not engage in any unlawful discriminatory practice in violation of Title 8 of the Administrative Code; and

36.5.2 Any failure to comply with this Article 36.5 may subject the **Contractor** to the remedies set forth in Section 6-123 of the Administrative Code, including, where appropriate, sanctions such as withholding of payment, imposition of an employment program, finding the **Contractor** to be in default, cancellation of the **Contract**, or any other sanction or remedy provided by **Law** or **Contract**.

### **ARTICLE 37. LABOR LAW REQUIREMENTS**

37.1 The **Contractor** shall strictly comply with all applicable provisions of the Labor Law, as amended. Such compliance is a material term of this **Contract**.

37.2 The **Contractor** specifically agrees, as required by Labor Law Sections 220 and 220-d, as amended, that:

37.2.1 Hours of **Work**: No laborer, worker, or mechanic in the employ of the **Contractor**, **Subcontractor** or other person doing or contracting to do the whole or a part of the **Work** contemplated by this **Contract** shall be permitted or required to work more than eight (8) hours in any one (1) **Day**, or more than five (5) **Days** in any one (1) week, except as provided in the Labor Law and in cases of extraordinary emergency including fire, flood, or danger to life or property, or in the case of national emergency when so proclaimed by the President of the United States of America.

37.2.2 In situations in which there are not sufficient laborers, workers, and mechanics who may be employed to carry on expeditiously the **Work** contemplated by this **Contract** as a result of such restrictions upon the number of hours and **Days** of labor, and the immediate commencement or prosecution or completion without undue delay of the **Work** is necessary for the preservation of the **Site** and/or for the protection of the life and limb of the persons using the same, such laborers, workers, and mechanics shall be permitted or required to work more than eight (8) hours in any one (1) **Day**; or five (5) **Days** in any one (1) week; provided, however, that upon application of any **Contractor**, the **Commissioner** shall have first certified to the Commissioner of Labor of the State of New York (hereinafter "Commissioner of Labor") that such public **Work** is of an important nature and that a delay in carrying it to completion would result in serious disadvantage to the public; and provided, further, that such Commissioner of Labor shall have determined that such an emergency does in fact exist as provided in Labor Law Section 220.2.

37.2.3 Failure of the **Commissioner** to make such a certification to the Commissioner of Labor shall not entitle the **Contractor** to damages for delay or for any cause whatsoever.

37.2.4 Prevailing Rate of Wages: The wages to be paid for a legal day's **Work** to laborers, workers, or mechanics employed upon the **Work** contemplated by this **Contract** or upon any materials to be used thereon shall not be less than the "prevailing rate of wage" as defined in Labor Law Section 220, and as fixed by the **Comptroller** in the attached Schedule of Wage Rates and in updated schedules thereof. The prevailing wage rates and supplemental benefits to be paid are those in effect at the time the **Work** is being performed.

37.2.5 Requests for interpretation or correction in the Information for Bidders includes all requests for clarification of the classification of trades to be employed in the performance of the **Work** under this **Contract**. In the event that a trade not listed in the **Contract** is in fact employed during the performance of this **Contract**, the **Contractor** shall be required to obtain from the **Agency** the prevailing wage rates and supplementary benefits for the trades used and to complete the performance of this **Contract** at the price at which the **Contract** was awarded.

37.2.6 Minimum Wages: Except for employees whose wage is required to be fixed pursuant to Labor Law Section 220, all persons employed by the **Contractor** and any **Subcontractor** in the manufacture or furnishing of the supplies, materials, or equipment, or the furnishing of work, labor, or services, used in the performance of this **Contract**, shall be paid, without subsequent deduction or rebate unless expressly authorized by **Law**, not less than the sum mandated by **Law**.

37.3 Working Conditions: No part of the **Work**, labor or services shall be performed or rendered by the **Contractor** in any plants, factories, buildings or surroundings or under working conditions which are unsanitary or hazardous or dangerous to the health and safety of employees engaged in the performance of this **Contract**. Compliance with the safety, sanitary, and factory inspection **Laws** of the state in which the **Work** is to be performed shall be prima facie evidence of compliance with this Article 37.3.

37.4 Prevailing Wage Enforcement: The **Contractor** agrees to pay for all costs incurred by the **City** in enforcing prevailing wage requirements, including the cost of any investigation conducted by or on behalf of the **Agency** or the **Comptroller**, where the **City** discovers a failure to comply with any of the requirements of this Article 37 by the **Contractor** or its **Subcontractor(s)**. The **Contractor** also agrees that, should it fail or refuse to pay for any such investigation, the **Agency** is hereby authorized to deduct from a **Contractor's** account an amount equal to the cost of such investigation.

37.4.1 The Labor Law Section 220 and Section 220-d, as amended, provide that this **Contract** shall be forfeited and no sum paid for any **Work** done hereunder on a second conviction for willfully paying less than:

37.4.1(a) The stipulated prevailing wage scale as provided in Labor Law section 220, as amended, or

37.4.1(b) The stipulated minimum hourly wage scale as provided in Labor Law section 220-d, as amended.

37.4.2 For any breach or violation of either working conditions (Article 37.3) or minimum wages (Article 37.2.6) provisions, the party responsible therefor shall be liable to the **City** for liquidated damages, which may be withheld from any amounts due on any contracts with the **City** of such party responsible, or may be recovered in actions brought by the **City**



Corporation Counsel in the name of the **City**, in addition to damages for any other breach of this **Contract**, for a sum equal to the amount of any underpayment of wages due to any employee engaged in the performance of this **Contract**. In addition, the **Commissioner** shall have the right to cancel contracts and enter into other contracts for the completion of the original contract, with or without public letting, and the original **Contractor** shall be liable for any additional cost. All sums withheld or recovered as deductions, rebates, refunds, or underpayment of wages hereunder, shall be held in a special deposit account and shall be paid without interest, on order of the **Comptroller**, directly to the employees who have been paid less than minimum rates of pay as set forth herein and on whose account such sums were withheld or recovered, provided that no claims by employees for such payments shall be entertained unless made within two (2) years from the date of actual notice to the **Contractor** of the withholding or recovery of such sums by the **City**.

37.4.3 A determination by the **Comptroller** that a **Contractor** and/or its **Subcontractor** willfully violated Labor Law Section 220 will be forwarded to the **City's** five District Attorneys for review.

37.4.4 The **Contractor's** or **Subcontractor's** noncompliance with this Article 37.4 and Labor Law Section 220 may result in an unsatisfactory performance evaluation and the **Comptroller** may also find and determine that the **Contractor** or **Subcontractor** willfully violated the New York Labor **Law**.

37.4.4(a) An unsatisfactory performance evaluation for noncompliance with this Article 37.4 may result in a determination that the **Contractor** is a non-responsible bidder on subsequent procurements with the **City** and thus a rejection of a future award of a contract with the **City**, as well as any other sanctions provided for by **Law**.

37.4.4(b) Labor Law Section 220-b, as amended, provides that when two (2) final determinations have been rendered against a **Contractor** or **Subcontractor** within any consecutive six (6) year period determining that such **Contractor** or **Subcontractor** has willfully failed to pay the prevailing rate of wages or to provide supplements in accordance with the Labor Law and this Article 37.4, whether such failures were concurrent or consecutive and whether or not such final determinations concerning separate public works projects are rendered simultaneously, such **Contractor** or **Subcontractor** shall be ineligible to submit a bid on or be awarded any public works contract with the **City** for a period of five (5) years from the second final determination. If the final determination involves the falsification of payroll records or the kickback of wages or supplements, the **Contractor** or **Subcontractor** shall be ineligible to submit a bid on or be awarded any public works contract with the **City** for a period of five (5) years from the first final determination.

37.4.4(c) Labor Law Section 220, as amended, provides that the **Contractor** or **Subcontractor** found to have violated this Article 37.4 may be directed to make payment of wages or supplements including interest found to be due, and the **Contractor** or **Subcontractor** may be directed to make payment of a further sum as a civil penalty in an amount not exceeding twenty-five (25%) percent of the total amount found to be due.

37.5 The **Contractor** and its **Subcontractors** shall within ten (10) **Days** after mailing of a Notice of Award or written order, post in prominent and conspicuous places in each and every plant, factory, building, and structure where employees of the **Contractor** and its **Subcontractors** engaged in the

performance of this **Contract** are employed, notices furnished by the **City**, in relation to prevailing wages and supplements, minimum wages, and other stipulations contained in Sections 220 and 220-h of the Labor Law, and the **Contractor** and its **Subcontractors** shall continue to keep such notices posted in such prominent and conspicuous places until **Final Acceptance** of the supplies, materials, equipment, or **Work**, labor, or services required to be furnished or rendered under this **Contract**.

37.6 The **Contractor** shall strictly comply with all of the provisions of Articles 37.6.1 through 37.6.5, and provide for all workers, laborers or mechanics in its employ, the following:

37.6.1 Notices Posted At **Site**: Post, in a location designated by the **City**, schedules of prevailing wages and supplements for this **Project**, a copy of all re-determinations of such schedules for the **Project**, the Workers' Compensation Law Section 51 notice, all other notices required by Law to be posted at the **Site**, the **City** notice that this **Project** is a public works project on which each worker is entitled to receive the prevailing wages and supplements for the occupation at which he or she is working, and all other notices which the **City** directs the **Contractor** to post. The **Contractor** shall provide a surface for such notices which is satisfactory to the **City**. The **Contractor** shall maintain and keep current such notices in a legible manner and shall replace any notice or schedule which is damaged, defaced, illegible or removed for any reason. The **Contractor** shall post such notices before commencing any **Work** on the **Site** and shall maintain such notices until all **Work** on the **Site** is complete; and

37.6.2 Daily **Site** Sign-in Sheets: Maintain daily **Site** sign-in sheets, and require that **Subcontractors** maintain daily **Site** sign-in sheets for its employees, which include blank spaces for an employee's name to be both printed and signed, job title, date started and Social Security number, the time the employee began work and the time the employee left work, until **Final Acceptance** of the supplies, materials, equipment, or **Work**, labor, or services to be furnished or rendered under this **Contract** unless exception is granted by the **Comptroller** upon application by the **Agency**. In the alternative, subject to the approval of the **CCPO**, the **Contractor** and **Subcontractor** may maintain an electronic or biometric sign-in system, which provides the information required by this Article 37.6.2; and

37.6.3 Individual Employee Information Notices: Distribute a notice to each worker, laborer or mechanic employed under this **Contract**, in a form provided by the **Agency**, that this **Project** is a public works project on which each worker, laborer or mechanic is entitled to receive the prevailing rate of wages and supplements for the occupation at which he or she is working. If the total cost of the **Work** under this **Contract** is at least two hundred fifty thousand (\$250,000) dollars, such notice shall also include a statement that each worker, laborer or mechanic must be certified prior to performing any **Work** as having successfully completed a course in construction safety and health approved by the United States Department of Labor's Occupational Safety and Health Administration that is at least ten (10) hours in duration. Such notice shall be distributed to each worker before he or she starts performing any **Work** of this **Contract** and with the first paycheck after July first of each year. "Worker, laborer or mechanic" includes employees of the **Contractor** and all **Subcontractors** and all employees of suppliers entering the **Site**. At the time of distribution, the **Contractor** shall have each worker, laborer or mechanic sign a statement, in a form provided by the **Agency**, certifying that the worker has received the notice required by this Article 37.6.3, which signed statement shall be maintained with the payroll records required by this **Contract**; and

37.6.3(a) The **Contractor** and each **Subcontractor** shall notify each worker, laborer or mechanic employed under this **Contract** in writing of the prevailing rate of

wages for their particular job classification. Such notification shall be given to every worker, laborer, and mechanic on their first pay stub and with every pay stub thereafter; and

37.6.4 **Site Laminated Identification Badges:** The **Contractor** shall provide laminated identification badges which include a photograph of the worker's, laborer's or mechanic's face and indicate the worker's, laborer's or mechanic's name, trade, employer's name, and employment starting date (month/day/year). Further, the **Contractor** shall require as a condition of employment on the **Site**, that each and every worker, laborer or mechanic wear the laminated identification badge at all times and that it may be seen by any representative of the **City**. The **Commissioner** may grant a written waiver from the requirement that the laminated identification badge include a photograph if the **Contractor** demonstrates that the identity of an individual wearing a laminated identification badge can be easily verified by another method; and

37.6.5 **Language Other Than English Used On Site:** Provide the **ACCO** notice when three (3) or more employees (worker and/or laborer and/or mechanic) on the **Site**, at any time, speak a language other than English. The **ACCO** will then provide the **Contractor** the notices described in Article 37.6.1 in that language or languages as may be required. The **Contractor** is responsible for all distributions under this Article 37; and

37.6.6 **Provision of Records:** The **Contractor** and **Subcontractor(s)** shall produce within five (5) **Days** on the **Site** of the **Work** and upon a written order of the **Engineer**, the **Commissioner**, the **ACCO**, the **Agency EAO**, or the **Comptroller**, such records as are required to be kept by this Article 37.6; and

37.6.7 The **Contractor** and **Subcontractor(s)** shall pay employees by check or direct deposit. If this **Contract** is for an amount greater than one million (\$1,000,000) dollars, checks issued by the **Contractor** to covered employees shall be generated by a payroll service or automated payroll system (an in-house system may be used if approved by the **Agency**). For any subcontract for an amount greater than seven hundred fifty thousand (\$750,000) dollars, checks issued by a **Subcontractor** to covered employees shall be generated by a payroll service or automated payroll system (an in-house system may be used if approved by the **Agency**); and

37.6.8 The failure of the **Contractor** or **Subcontractor(s)** to comply with the provisions of Articles 37.6.1 through 37.6.7 may result in the **Commissioner** declaring the **Contractor** in default and/or the withholding of payments otherwise due under the **Contract**.

37.7 The **Contractor** and its **Subcontractors** shall keep such employment and payroll records as are required by Section 220 of the Labor Law. The failure of the **Contractor** or **Subcontractor(s)** to comply with the provisions of this Article 37.7 may result in the **Commissioner** declaring the **Contractor** in default and/or the withholding of payments otherwise due under the **Contract**.

37.8 At the time the **Contractor** makes application for each partial payment and for final payment, the **Contractor** shall submit to the **Commissioner** a written payroll certification, in the form provided by this **Contract**, of compliance with the prevailing wage, minimum wage, and other provisions and stipulations required by Labor Law Section 220 and of compliance with the training requirements of Labor Law Section 220-h set forth in Article 35.2. This certification of compliance shall be a condition precedent to payment and no payment shall be made to the **Contractor** unless and until each such certification shall have been submitted to and received by the **Commissioner**.

37.9 This **Contract** is executed by the **Contractor** with the express warranty and representation that the **Contractor** is not disqualified under the provisions of Section 220 of the Labor Law from the award of the **Contract**.

37.10 Any breach or violation of any of the foregoing shall be deemed a breach or violation of a material provision of this **Contract**, and grounds for cancellation thereof by the **City**.

### **ARTICLE 38. PAYROLL REPORTS**

38.1 The **Contractor** and its **Subcontractor(s)** shall maintain on the **Site** during the performance of the **Work** the original payrolls or transcripts thereof which the **Contractor** and its **Subcontractor(s)** are required to maintain and shall submit such original payrolls or transcripts, subscribed and affirmed by it as true, within thirty (30) **Days** after issuance of its first payroll, and every thirty (30) **Days** thereafter, pursuant to Labor Law Section 220(3-a)(a)(iii). The **Contractor** and **Subcontractor(s)** shall submit such original payrolls or transcripts along with each and every payment requisition. If payment requisitions are not submitted at least once a month, the **Contractor** and its **Subcontractor(s)** shall submit original payrolls and transcripts both along with its payment requisitions and independently of its payment requisitions.

38.2 The **Contractor** shall maintain payrolls or transcripts thereof for six (6) years from the date of completion of the **Work** on this **Contract**. If such payrolls and transcripts are maintained outside of New York City after the completion of the **Work** and their production is required pursuant to this Article 38, the **Contractor** shall produce such records in New York City upon request by the **City**.

38.3 The **Contractor** and **Subcontractor(s)** shall comply with any written order, direction, or request made by the **Engineer**, the **Commissioner**, the **ACCO**, the **Agency EAO**, the **Agency Labor Law Investigator(s)**, or the **Comptroller**, to provide to the requesting party any of the following information and/or records within five (5) **Days** of such written order, direction, or request:

38.3.1 Such original payrolls or transcripts thereof subscribed and affirmed by it as true and the statements signed by each worker pursuant to this Chapter VIII; and/or

38.3.2 Attendance sheets for each **Day** on which any employee of the **Contractor** and/or any of the **Subcontractor(s)** performed **Work** on the **Site**, which attendance sheet shall be in a form acceptable to the **Agency** and shall provide information acceptable to the **Agency** to identify each such employee; and/or

38.3.3 Any other information to satisfy the **Engineer**, the **Commissioner**, the **ACCO**, the **Agency EAO**, the **Agency Labor Law Investigator(s)** or the **Comptroller**, that this Chapter VIII and the Labor Law, as to the hours of employment and prevailing rates of wages and/or supplemental benefits, are being observed.

38.4 The failure of the **Contractor** or **Subcontractor(s)** to comply with the provisions of Articles 38.1 and/or 38.2 may result in the **Commissioner** declaring the **Contractor** in default and/or the withholding of payments otherwise due under the **Contract**.

### **ARTICLE 39. DUST HAZARDS**

39.1 Should a harmful dust hazard be created in performing the **Work** of this **Contract**, for the elimination of which appliances or methods have been approved by the Board of Standards and Appeals

of the City of New York, such appliances and methods shall be installed, maintained, and effectively operated during the continuance of such harmful dust hazard. Failure to comply with this provision after notice shall make this **Contract** voidable at the sole discretion of the **City**.

## **CHAPTER IX: PARTIAL AND FINAL PAYMENTS**

### **ARTICLE 40. CONTRACT PRICE**

40.1 The **City** shall pay, and the **Contractor** agrees to accept, in full consideration for the **Contractor's** performance of the **Work** subject to the terms and conditions hereof, the lump sum price or unit prices for which this **Contract** was awarded, plus the amount required to be paid for any **Extra Work** ordered by the **Commissioner** under Article 25, less credit for any **Work** omitted pursuant to Article 29.

### **ARTICLE 41. BID BREAKDOWN ON LUMP SUM**

41.1 Within fifteen (15) **Days** after the commencement date specified in the **Notice to Proceed** or **Order to Work**, unless otherwise directed by the **Resident Engineer**, the **Contractor** shall submit to the **Resident Engineer** a breakdown of its bid price, or of lump sums bid for items of the **Contract**, showing the various operations to be performed under the **Contract**, as directed in the progress schedule required under Article 9, and the value of each of such operations, the total of such items to equal the lump sum price bid. Said breakdown must be approved in writing by the **Resident Engineer**.

41.2 No partial payment will be approved until the **Contractor** submits a bid breakdown that is acceptable to the **Resident Engineer**.

41.3 The **Contractor** shall also submit such other information relating to the bid breakdown as directed by the **Resident Engineer**. Thereafter, the breakdown may be used only for checking the **Contractor's** applications for partial payments hereunder, but shall not be binding upon the **City**, the **Commissioner**, or the **Engineer** for any purpose whatsoever.

### **ARTICLE 42. PARTIAL PAYMENTS**

42.1 From time to time as the **Work** progresses satisfactorily, but not more often than once each calendar month (except where the **Commissioner** approves in writing the submission of invoices on a more frequent basis and for invoices relating to **Work** performed pursuant to a change order), the **Contractor** may submit to the **Engineer** a requisition for a partial payment in the prescribed form, which shall contain an estimate of the quantity and the fair value of the **Work** done during the payment period.

42.2 Partial payments may be made for materials, fixtures, and equipment in advance of their actual incorporation in the **Work**, as the **Commissioner** may approve, and upon the terms and conditions set forth in the General Conditions.

42.3 The **Contractor** shall also submit to the **Commissioner** in connection with every application for partial payment a verified statement in the form prescribed by the **Comptroller** setting forth the information required under Labor Law Section 220-a.

42.4 Within thirty (30) **Days** after receipt of a satisfactory payment application, and within sixty (60) **Days** after receipt of a satisfactory payment application in relation to **Work** performed pursuant to a change order, the **Engineer** will prepare and certify, and the **Commissioner** will approve, a voucher for a partial payment in the amount of such approved estimate, less any and all deductions authorized to be made by the **Commissioner** under the terms of this **Contract** or by **Law**.

#### **ARTICLE 43. PROMPT PAYMENT**

43.1 The Prompt Payment provisions of the **PPB** Rules in effect at the time of the bid will be applicable to payments made under this **Contract**. The provisions require the payment to the **Contractor** of interest on payments made after the required payment date, except as set forth in the **PPB** Rules.

43.2 The **Contractor** shall submit a proper invoice to receive payment, except where the **Contract** provides that the **Contractor** will be paid at predetermined intervals without having to submit an invoice for each scheduled payment.

43.3 Determination of interest due will be made in accordance with the **PPB** Rules.

43.4 If the **Contractor** is paid interest, the proportionate share(s) of that interest shall be forwarded by the **Contractor** to its **Subcontractor(s)**.

43.5 The **Contractor** shall pay each **Subcontractor** or **Materialman** not later than seven (7) **Days** after receipt of payment out of amounts paid to the **Contractor** by the **City** for **Work** performed by the **Subcontractor** or **Materialman** under this **Contract**.

43.5.1 If **Contractor** fails to make any payment to any **Subcontractor** or **Materialman** within seven (7) **Days** after receipt of payment by the **City** pursuant to this Article 43.5, then the **Contractor** shall pay interest on amounts due to such **Subcontractor** or **Materialman** at the rate of interest in effect on the date such payment is made by the **Contractor** computed in accordance with Section 756-b (1)(b) of the New York General Business Law. Accrual of interest shall commence on the **Day** immediately following the expiration of the seventh **Day** following receipt of payment by the **Contractor** from the **City** and shall end on the date on which payment is made.

43.6 The **Contractor** shall include in each of its subcontracts a provision requiring each **Subcontractor** to make payment to each of its **Subcontractors** or **Materialmen** for **Work** performed under this **Contract** in the same manner and within the same time period set forth above.

#### **ARTICLE 44. SUBSTANTIAL COMPLETION PAYMENT**

44.1 The **Contractor** shall submit with the **Substantial Completion** requisition:

44.1.1 A final verified statement of any pending Article 27 disputes in accordance with the **PPB** Rules and this **Contract** and any and all alleged claims against the **City**, in any way connected with or arising out of this **Contract** (including those as to which details may have been furnished pursuant to Articles 11, 27, 28, and 30) setting forth with respect to each such claim the total amount thereof, the various items of labor and materials included therein, and the alleged value of each item; and if the alleged claim be one for delay, the alleged cause of each such delay, the period or periods of time, giving the dates when the

**Contractor** claims the performance of the **Work** or a particular part thereof was delayed, and an itemized statement and breakdown of the amount claimed for each such delay.

44.1.1(a) With respect to each such claim, the **Commissioner**, the **Comptroller** and, in the event of litigation, the **City Corporation Counsel** shall have the same right to inspect, and to make extracts or copies of, the **Contractor's** books, vouchers, records, etc., as is referred to in Articles 11, 27, 28, and 30. Nothing contained in this Article 44.1.1(a) is intended to or shall relieve the **Contractor** from the obligation of complying strictly with Articles 11, 27, 28, and 30. The **Contractor** is warned that unless such claims are completely set forth as herein required, the **Contractor** upon acceptance of the **Substantial Completion** payment pursuant to this Article 44, will have waived any such claims.

44.1.2 **A Final Approved Punch List.**

44.1.3 Where required, a request for an extension of time to achieve **Substantial Completion** or final extension of time.

44.2 The **Commissioner** shall issue a voucher calling for payment of any part or all of the balance due for **Work** performed under the **Contract**, including monies retained under Article 21, less any and all deductions authorized to be made by the **Commissioner**, under this **Contract** or by **Law**, and less twice the amount the **Commissioner** considers necessary to ensure the completion of the balance of the **Work** by the **Contractor**. Such a payment shall be considered a partial and not a final payment. No **Substantial Completion** payment shall be made under this Article 44 where the **Contractor** failed to complete the **Work** within the time fixed for such completion in the Schedule A of the General Conditions, or within the time to which completion may have been extended, until an extension or extensions of time for the completion of **Work** have been acted upon pursuant to Article 13.

44.3 No further partial payments shall be made to the **Contractor** after **Substantial Completion**, except the **Substantial Completion** payment and payment pursuant to any **Contractor's** requisition that were properly filed with the **Commissioner** prior to the date of **Substantial Completion**; however, the **Commissioner** may grant a waiver for further partial payments after the date of **Substantial Completion** to permit payments for change order **Work** and/or release of retainage and deposits pursuant to Articles 21 and 24. Such waiver shall be in writing.

44.4 The **Contractor** acknowledges that nothing contained in this Article 44 is intended to or shall in any way diminish the force and effect of Article 13.

## **ARTICLE 45. FINAL PAYMENT**

45.1 After completion and **Final Acceptance** of the **Work**, the **Contractor** shall submit all required certificates and documents, together with a requisition for the balance claimed to be due under the **Contract**, less the amount authorized to be retained for maintenance under Article 24. Such submission shall be within 90 days of the date of the **Commissioner's** written determination of **Final Acceptance**, or within such additional time as may be granted by the **Commissioner** in writing. If the **Contractor** fails to submit all required certificates and documents within the time allowed, no payment of the balance claimed shall be made to the **Contractor** and the **Contractor** shall be deemed to have forfeited its right to payment of any balance claimed. A verified statement similar to that required in connection with applications for partial payments shall also be submitted to the **Commissioner**.

45.2 Amended Verified Statement of Claims: The **Contractor** shall also submit with the final requisition any amendments to the final verified statement of any pending dispute resolution procedures in accordance with the **PPB** Rules and this **Contract** and any and all alleged claims against the **City**, in any way connected with or arising out of this **Contract** (including those as to which details may have been furnished pursuant to Articles 11, 27, 28, and 30) that have occurred subsequent to **Substantial Completion**, setting forth with respect to each such claim the total amount thereof, the various items of labor and materials included therein, and the alleged value of each such item; and if the alleged claim be one for delay, the alleged cause of each such delay, the period or periods of time, giving the dates when the **Contractor** claims the performance of the **Work** or a particular part thereof was delayed, and an itemized statement and breakdown of the amount claimed for each such delay. With reference to each such claim, the **Commissioner**, the **Comptroller** and, in the event of litigation, the **City** Corporation Counsel shall have the same right to inspect, and to make extracts or copies of, the **Contractor's** books, vouchers, records, etc., as is referred to in Articles 11, 27, 28, and 30. Nothing contained in this Article 45.2, is intended to or shall relieve the **Contractor** from the obligation of complying strictly with Articles 11, 27, 28, and 30. The **Contractor** is warned that unless such claims are completely set forth as herein required, the **Contractor**, upon acceptance of the Final Payment pursuant to Article 46, will have waived any such claims.

45.3 Preparation of Final Voucher: Upon determining the balance due hereunder other than on account of claims, the **Engineer** will prepare and certify, for the Commissioner's approval, a voucher for final payment in that amount less any and all deductions authorized to be made by the **Commissioner** under this **Contract** or by **Law**. In the case of a lump sum **Contract**, the **Commissioner** shall certify the voucher for final payment within thirty (30) **Days** from the date of completion and acceptance of the **Work**, provided all requests for extensions of time have been acted upon.

45.3.1 All prior certificates and vouchers upon which partial payments were made, being merely estimates made to enable the **Contractor** to prosecute the **Work** more advantageously, shall be subject to correction in the final voucher, and the certification of the **Engineer** thereon and the approval of the **Commissioner** thereof, shall be conditions precedent to the right of the **Contractor** to receive any money hereunder. Such final voucher shall be binding and conclusive upon the **Contractor**.

45.3.2 Payment pursuant to such final voucher, less any deductions authorized to be made by the **Commissioner** under this **Contract** or by **Law**, shall constitute the final payment, and shall be made by the **Comptroller** within thirty (30) **Days** after the filing of such voucher in his/her office.

45.4 The **Contractor** acknowledges that nothing contained in this Article 45 is intended to or shall in any way diminish the force and effect of Article 13.

#### **ARTICLE 46. ACCEPTANCE OF FINAL PAYMENT**

46.1 The acceptance by the **Contractor**, or by anyone claiming by or through it, of the final payment, whether such payment be made pursuant to any judgment of any court, or otherwise, shall constitute and operate as a release of the **City** from any and all claims of and liability to the **Contractor** for anything heretofore done or furnished for the **Contractor** relating to or arising out of this **Contract** and the **Work** done hereunder, and for any prior act, neglect or default on the part of the **City** or any of its officials, agents or employees, excepting only a claim against the **City** for the amounts deducted or retained in accordance with the terms and provisions of this **Contract** or by **Law**, and excepting any claims, not otherwise waived, or any pending dispute resolution procedures which are contained in the



verified statement filed with the **Contractor's** substantial and final requisitions pursuant to Articles 44 and 45.

46.2 The **Contractor** is warned that the execution by it of a release, in connection with the acceptance of the final payment, containing language purporting to reserve claims other than those herein specifically excepted from the operation of this Article 46, or those for amounts deducted by the **Commissioner** from the final requisition or from the final payment as certified by the **Engineer** and approved by the **Commissioner**, shall not be effective to reserve such claims, anything stated to the **Contractor** orally or in writing by any official, agent or employee of the **City** to the contrary notwithstanding.

46.3 Should the **Contractor** refuse to accept the final payment as tendered by the **Comptroller**, it shall constitute a waiver of any right to interest thereon.

46.4 The **Contractor**, however, shall not be barred by this Article 46 from commencing an action for breach of **Contract** to the extent permitted by **Law** and by the terms of the **Contract** for any claims that are contained in the verified statement filed with the **Contractor's** substantial and final requisitions pursuant to Articles 44 and 45 or that arose after submission of the final payment requisition, provided that a detailed and verified statement of claim is served upon the contracting **Agency** and **Comptroller** not later than forty (40) **Days** after the making of such final payment by electronic funds transfer (EFT) or the mailing of such final payment. The statement shall specify the items upon which the claim will be based and any such claim shall be limited to such items.

#### **ARTICLE 47. APPROVAL BY PUBLIC DESIGN COMMISSION**

47.1 All works of art, including paintings, mural decorations, stained glass, statues, bas-reliefs, and other sculptures, monuments, fountains, arches, and other structures of a permanent character intended for ornament or commemoration, and every design of the same to be used in the performance of this **Contract**, and the design of all bridges, approaches, buildings, gates, fences, lamps, or structures to be erected, pursuant to the terms of this **Contract**, shall be submitted to the Art Commission, d/b/a the Public Design Commission of the City of New York, and shall be approved by the Public Design Commission prior to the erection or placing in position of the same. The final payment shall not become due or payable under this **Contract** unless and until the Public Design Commission shall certify that the design for the **Work** herein contracted for has been approved by the said Public Design Commission, and that the same has been executed in substantial accordance with the design so approved, pursuant to the provisions of Chapter 37, Section 854 of the **City** Charter, as amended.

### **CHAPTER X: CONTRACTOR'S DEFAULT**

#### **ARTICLE 48. COMMISSIONER'S RIGHT TO DECLARE CONTRACTOR IN DEFAULT**

48.1 In addition to those instances specifically referred to in other Articles herein, the **Commissioner** shall have the right to declare the **Contractor** in default of this **Contract** if:

48.1.1 The **Contractor** fails to commence **Work** when notified to do so by the **Commissioner**; or if

48.1.2 The **Contractor** shall abandon the **Work**; or if

48.1.3 The **Contractor** shall refuse to proceed with the **Work** when and as directed by the **Commissioner**; or if

48.1.4 The **Contractor** shall, without just cause, reduce its working force to a number which, if maintained, would be insufficient, in the opinion of the **Commissioner**, to complete the **Work** in accordance with the progress schedule; or if

48.1.5 The **Contractor** shall fail or refuse to increase sufficiently such working force when ordered to do so by the **Commissioner**; or if

48.1.6 The **Contractor** shall sublet, assign, transfer, convert or otherwise dispose of this **Contract** other than as herein specified; or sell or assign a majority interest in the **Contractor**; or if

48.1.7 The **Contractor** fails to secure and maintain all required insurance; or if

48.1.8 A receiver or receivers are appointed to take charge of the **Contractor's** property or affairs; or if

48.1.9 The **Commissioner** shall be of the opinion that the **Contractor** is or has been unnecessarily or unreasonably or willfully delaying the performance and completion of the **Work**, or the award of necessary subcontracts, or the placing of necessary material and equipment orders; or if

48.1.10 The **Commissioner** shall be of the opinion that the **Contractor** is or has been willfully or in bad faith violating any of the provisions of this **Contract**; or if

48.1.11 The **Commissioner** shall be of the opinion that the **Work** cannot be completed within the time herein provided therefor or within the time to which such completion may have been extended; provided, however, that the impossibility of timely completion is, in the **Commissioner's** opinion, attributable to conditions within the **Contractor's** control; or if

48.1.12 The **Work** is not completed within the time herein provided therefor or within the time to which the **Contractor** may be entitled to have such completion extended; or if

48.1.13 Any statement or representation of the **Contractor** in the **Contract** or in any document submitted by the **Contractor** with respect to the **Work**, the **Project**, or the **Contract** (or for purposes of securing the **Contract**) was untrue or incorrect when made; or if

48.1.14 The **Contractor** or any of its officers, directors, partners, five (5%) percent shareholders, principals, or other persons substantially involved in its activities, commits any of the acts or omissions specified as the grounds for debarment in the **PPB Rules**.

48.2 Before the **Commissioner** shall exercise his/her right to declare the **Contractor** in default, the **Commissioner** shall give the **Contractor** an opportunity to be heard, upon not less than two (2) **Days'** notice.

## **ARTICLE 49. EXERCISE OF THE RIGHT TO DECLARE DEFAULT**

49.1 The right to declare the **Contractor** in default for any of the grounds specified or referred to in Article 48 shall be exercised by sending the **Contractor** a notice, signed by the **Commissioner**, setting forth the ground or grounds upon which such default is declared (hereinafter referred to as a “Notice of Default”).

49.2 The **Commissioner’s** determination that the **Contractor** is in default shall be conclusive, final, and binding on the parties and such a finding shall preclude the **Contractor** from commencing a plenary action for any damages relating to the **Contract**. If the **Contractor** protests the determination of the **Commissioner**, the **Contractor** may commence an action in a court of competent jurisdiction of the State of New York under Article 78 of the New York Civil Practice Law and Rules.

## **ARTICLE 50. QUITTING THE SITE**

50.1 Upon receipt of such notice the **Contractor** shall immediately discontinue all further operations under this **Contract** and shall immediately quit the **Site**, leaving untouched all plant, materials, equipment, tools, and supplies then on the **Site**.

## **ARTICLE 51. COMPLETION OF THE WORK**

51.1 The **Commissioner**, after declaring the **Contractor** in default, may then have the **Work** completed by such means and in such manner, by contract with or without public letting, or otherwise, as he/she may deem advisable, utilizing for such purpose such of the **Contractor’s** plant, materials, equipment, tools, and supplies remaining on the **Site**, and also such **Subcontractors**, as he/she may deem advisable.

51.2 After such completion, the **Commissioner** shall make a certificate stating the expense incurred in such completion, which shall include the cost of re-letting and also the total amount of liquidated damages (at the rate provided for in the **Contract**) from the date when the **Work** should have been completed by the **Contractor** in accordance with the terms hereof to the date of actual completion of the **Work**. Such certificate shall be binding and conclusive upon the **Contractor**, its sureties, and any person claiming under the **Contractor**, as to the amount thereof.

51.3 The expense of such completion, including any and all related and incidental costs, as so certified by the **Commissioner**, and any liquidated damages assessed against the **Contractor**, shall be charged against and deducted out of monies which are earned by the **Contractor** prior to the date of default. Should the expense of such completion, as certified by the **Commissioner**, exceed the total sum which would have been payable under the **Contract** if it had been completed by the **Contractor**, any excess shall be paid by the **Contractor**.

## **ARTICLE 52. PARTIAL DEFAULT**

52.1 In case the **Commissioner** shall declare the **Contractor** in default as to a part of the **Work** only, the **Contractor** shall discontinue such part, shall continue performing the remainder of the **Work** in strict conformity with the terms of this **Contract**, and shall in no way hinder or interfere with any **Other Contractor(s)** or persons whom the **Commissioner** may engage to complete the **Work** as to which the **Contractor** was declared in default.

52.2 The provisions of this Chapter relating to declaring the **Contractor** in default as to the entire **Work** shall be equally applicable to a declaration of partial default, except that the **Commissioner** shall be entitled to utilize for completion of the part of the **Work** as to which the **Contractor** was declared in default only such plant, materials, equipment, tools, and supplies as had been previously used by the **Contractor** on such part.

### **ARTICLE 53. PERFORMANCE OF UNCOMPLETED WORK**

53.1 In completing the whole or any part of the **Work** under the provisions of this Chapter X, the **Commissioner** shall have the power to depart from or change or vary the terms and provisions of this **Contract**, provided, however, that such departure, change or variation is made for the purpose of reducing the time or expense of such completion. Such departure, change or variation, even to the extent of accepting a lesser or different performance, shall not affect the conclusiveness of the **Commissioner's** certificate of the cost of completion referred to in Article 51, nor shall it constitute a defense to an action to recover the amount by which such certificate exceeds the amount which would have been payable to the **Contractor** hereunder but for its default.

### **ARTICLE 54. OTHER REMEDIES**

54.1 In addition to the right to declare the **Contractor** in default pursuant to this Chapter X, the **Commissioner** shall have the absolute right, in his/her sole discretion and without a hearing, to complete or cause to be completed in the same manner as described in Articles 51 and 53, any or all unsatisfactory or uncompleted punch list **Work** that remains after the completion date specified in the **Final Approved Punch List**. A written notice of the exercise of this right shall be sent to the **Contractor** who shall immediately quit the **Site** in accordance with the provisions of Article 50.

54.2 The expense of completion permitted under Article 54.1, including any and all related and incidental costs, as so certified by the **Commissioner**, shall be charged against and deducted out of monies which have been earned by the **Contractor** prior to the date of the exercise of the right set forth in Article 54.1; the balance of such monies, if any, subject to the other provisions of this **Contract**, to be paid to the **Contractor** without interest after such completion. Should the expense of such completion, as certified by the **Commissioner**, exceed the total sum which would have been payable under the **Contract** if it had been completed by the **Contractor**, any excess shall be paid by the **Contractor**.

54.3 The previous provisions of this Chapter X shall be in addition to any and all other remedies available under **Law** or in equity.

54.4 The exercise by the **City** of any remedy set forth herein shall not be deemed a waiver by the **City** of any other legal or equitable remedy contained in this **Contract** or provided under **Law**.

## **CHAPTER XI: MISCELLANEOUS PROVISIONS**

### **ARTICLE 55. CONTRACTOR'S WARRANTIES**

55.1 In consideration of, and to induce, the award of this **Contract** to the **Contractor**, the **Contractor** represents and warrants:

55.1.1 That it is financially solvent, sufficiently experienced and competent to perform the **Work**; and

55.1.2 That the facts stated in its bid and the information given by it pursuant to the Information for Bidders is true and correct in all respects; and

55.1.3 That it has read and complied with all requirements set forth in the **Contract**.

#### **ARTICLE 56. CLAIMS AND ACTIONS THEREON**

56.1 Any claim, that is not subject to dispute resolution under the **PPB** Rules or this **Contract**, against the **City** for damages for breach of **Contract** shall not be made or asserted in any action, unless the **Contractor** shall have strictly complied with all requirements relating to the giving of notice and of information with respect to such claims, as herein before provided.

56.2 Nor shall any action be instituted or maintained on any such claims unless such action is commenced within six (6) months after **Substantial Completion**; except that:

56.2.1 Any claims arising out of events occurring after **Substantial Completion** and before **Final Acceptance** of the **Work** shall be asserted within six (6) months of **Final Acceptance** of the **Work**;

56.2.2 If the **Commissioner** exercises his/her right to complete or cause to complete any or all unsatisfactory or uncompleted punch list **Work** that remains after the completion date specified in the **Final Approved Punch List** pursuant to Article 54, any such action shall be commenced within six (6) months from the date the **Commissioner** notifies the **Contractor** in writing that he/she has exercised such right. Any claims for monies deducted, retained or withheld under the provisions of this **Contract** shall be asserted within six (6) months after the date when such monies otherwise become due and payable hereunder; and

56.2.3 If the **Commissioner** exercises his/her right to terminate the **Contract** pursuant to Article 64, any such action shall be commenced within six (6) months of the date the **Commissioner** exercises said right.

#### **ARTICLE 57. INFRINGEMENT**

57.1 The **Contractor** shall be solely responsible for and shall defend, indemnify, and hold the **City** harmless from any and all claims (even if the allegations of the lawsuit are without merit) and judgments for damages and from costs and expenses to which the **City** may be subject to or which it may suffer or incur allegedly arising out of or in connection with any infringement by the **Contractor** of any copyright, trade secrets, trademark or patent rights or any other property or personal right of any third party by the **Contractor** and/or its **Subcontractors** in the performance or completion of the **Work**. Insofar as the facts or **Law** relating to any claim would preclude the **City** from being completely indemnified by the **Contractor**, the **City** shall be partially indemnified by the **Contractor** to the fullest extent permitted by **Law**.

## **ARTICLE 58. NO CLAIM AGAINST OFFICIALS, AGENTS OR EMPLOYEES**

58.1 No claim whatsoever shall be made by the **Contractor** against any official, agent or employee of the **City** for, or on account of, anything done or omitted to be done in connection with this **Contract**.

## **ARTICLE 59. SERVICE OF NOTICES**

59.1 The **Contractor** hereby designates the business address, fax number, and email address specified in its bid, as the place where all notices, directions or other communications to the **Contractor** may be delivered, or to which they may be mailed. Any notice, direction, or communication from either party to the other shall be in writing and shall be deemed to have been given when (i) delivered personally; (ii) sent by certified mail, return receipt requested; (iii) delivered by overnight or same day courier service in a properly addressed envelope with confirmation; or (iv) sent by fax or email and, unless receipt of the fax or e-mail is acknowledged by the recipient by fax or e-mail, deposited in a post office box regularly maintained by the United States Postal Service in a properly addressed, postage pre-paid envelope.

59.2 **Contractor's** notice address, email address, or fax number may be changed at any time by an instrument in writing, executed and acknowledged by the **Contractor**, and delivered to the **Commissioner**.

59.3 Nothing herein contained shall, however, be deemed to preclude or render inoperative the service of any notice, direction or other communication upon the **Contractor** personally, or, if the **Contractor** is a corporation, upon any officer thereof.

## **ARTICLE 60. UNLAWFUL PROVISIONS DEEMED STRICKEN FROM CONTRACT**

60.1 If this **Contract** contains any unlawful provision not an essential part of the **Contract** and which shall not appear to have been a controlling or material inducement to the making thereof, the same shall be deemed of no effect and shall, upon notice by either party, be deemed stricken from the **Contract** without affecting the binding force of the remainder.

## **ARTICLE 61. ALL LEGAL PROVISIONS DEEMED INCLUDED**

61.1 It is the intent and understanding of the parties to this **Contract** that each and every provision of **Law** required to be inserted in this **Contract** shall be and is inserted herein. Furthermore, it is hereby stipulated that every such provision is to be deemed to be inserted herein, and if, through mistake or otherwise, any such provision is not inserted, or is not inserted in correct form, then this **Contract** shall forthwith upon the application of either party be amended by such insertion so as to comply strictly with the **Law** and without prejudice to the rights of either party hereunder.

## **ARTICLE 62. TAX EXEMPTION**

62.1 The **City** is exempt from payment of Federal, State, and local taxes, including sales and compensating use taxes of the State of New York and its cities and counties on all tangible personal property sold to the **City** pursuant to the provisions of this **Contract**. These taxes are not to be included in bids. However, this exemption does not apply to tools, machinery, equipment or other property leased by or to the **Contractor**, **Subcontractor** or **Materialman** or to tangible personal property which, even

though it is consumed, is not incorporated into the completed **Work** (consumable supplies) and tangible personal property that the **Contractor** is required to remove from the **Site** during or upon completion of the **Work**. The **Contractor** and its **Subcontractors** and **Materialmen** shall be responsible for and pay any and all applicable taxes, including sales and compensating use taxes, on such leased tools, machinery, equipment or other property and upon all such consumable supplies and tangible personal property that the **Contractor** is required to remove from the **Site** during or upon completion of the **Work**.

62.2 The **Contractor** agrees to sell and the **City** agrees to purchase all tangible personal property, other than consumable supplies and other tangible personal property that the **Contractor** is required to remove from the **Site** during or upon completion of the **Work**, that is required, necessary or proper for or incidental to the construction of the **Project** covered by this **Contract**. The sum paid under this **Contract** for such tangible personal property shall be in full payment and consideration for the sale of such tangible personal property.

62.2.1 The **Contractor** agrees to construct the **Project** and to perform all **Work**, labor and services rendered, necessary, proper or incidental thereto for the sum shown in the bid for the performance of such **Work**, labor, and services, and the sum so paid pursuant to this **Contract** for such **Work**, labor, and services, shall be in full consideration for the performance by the **Contractor** of all its duties and obligations under this **Contract** in connection with said **Work**, labor, and services.

62.3 20 NYCRR Section 541.3(d) provides that a **Contractor's** purchases of tangible personal property that is either incorporated into real property owned by a governmental entity or purchased for and sold to a governmental entity are exempt from sales and use tax. The **City** shall not pay sales tax for any such tangible personal property that it purchases from the **Contractor** pursuant to the **Contract**. With respect to such tangible personal property, the **Contractor**, at the request of the **City**, shall furnish to the **City** such bills of sale and other instruments as may be required by the **City**, properly executed, acknowledged and delivered assuring to the **City** title to such tangible personal property, free of liens and/or encumbrances, and the **Contractor** shall mark or otherwise identify all such tangible personal property as the property of the **City**.

62.4 Title to all tangible personal property to be sold by the **Contractor** to the **City** pursuant to the provisions of the **Contract** shall immediately vest in and become the sole property of the **City** upon delivery of such tangible personal property to the **Site**. Notwithstanding such transfer of title, the **Contractor** shall have the full and continuing responsibility to install such tangible personal property in accordance with the provisions of this **Contract**, protect it, maintain it in a proper condition and forthwith repair, replace and make good any damage thereto, theft or disappearance thereof, and furnish additional tangible personal property in place of any that may be lost, stolen or rendered unusable, without cost to the **City**, until such time as the **Work** covered by the **Contract** is fully accepted by the **City**. Such transfer of title shall in no way affect any of the **Contractor's** obligations hereunder. In the event that, after title has passed to the **City**, any of the tangible personal property is rejected as being defective or otherwise unsatisfactory, title to all such tangible personal property shall be deemed to have been transferred back to the **Contractor**.

62.5 The purchase by **Subcontractors** or **Materialmen** of tangible personal property to be sold hereunder shall be a purchase or procurement for resale to the **Contractor** (either directly or through other **Subcontractors**) and therefore not subject to the aforesaid sales and compensating use taxes, provided that the subcontracts and purchase agreements provide for the resale of such tangible personal property and that such subcontracts and purchase agreements are in a form similar to this **Contract** with respect to the separation of the sale of consumable supplies and tangible personal property that the

**Contractor** is required to remove from the **Site** during or upon completion of the **Work** from the **Work** and labor, services, and any other matters to be provided, and provided further that the subcontracts and purchase agreements provide separate prices for tangible personal property and all other services and matters. Such separation shall actually be followed in practice, including the separation of payments for tangible personal property from the payments for other **Work** and labor and other things to be provided.

62.6 The **Contractor** and its **Subcontractors** and **Materialmen** shall furnish a **Contractor** Exempt Purchase Certificate to all persons, firms or corporations from which they purchase tangible personal property for the performance of the **Work** covered by this **Contract**.

62.7 In the event any of the provisions of this Article 62 shall be deemed to be in conflict with any other provisions of this **Contract** or create any ambiguity, then the provisions of this Article 62 shall control.

### **ARTICLE 63. INVESTIGATION(S) CLAUSE**

63.1 The parties to this **Contract** agree to cooperate fully and faithfully with any investigation, audit or inquiry conducted by a United States, a State of New York (State) or a **City** governmental agency or authority that is empowered directly or by designation to compel the attendance of witnesses and to examine witnesses under oath, or conducted by the Inspector General of a governmental agency that is a party in interest to the transaction, submitted bid, submitted proposal, contract, lease, permit or license that is the subject of the investigation, audit or inquiry.

63.2 If any person who has been advised that his/her statement, and any information from such statement, will not be used against him/her in any subsequent criminal proceeding refuses to testify before a grand jury or other governmental agency or authority empowered directly or by designation to compel the attendance of witnesses and to examine witnesses under oath concerning the award of or performance under any transaction, agreement, lease, permit, contract, or license entered into with the **City**, the State, or any political subdivision or public authority thereof, or the Port Authority of New York and New Jersey, or any local development corporation within the **City**, or any public benefit corporation organized under the **Laws** of the State of New York, or;

63.3 If any person refuses to testify for a reason other than the assertion of his/her privilege against self incrimination in an investigation, audit or inquiry conducted by a **City** or State governmental agency or authority empowered directly or by designation to compel the attendance of witnesses and to take testimony under oath, or by the Inspector General of the governmental agency that is a party in interest in, and is seeking testimony concerning the award of, or performance under any transaction, agreement, lease, permit, contract, or license entered into with the **City**, the State, or any political subdivision thereof or any local development corporation within the **City**, then;

63.4 The **Commissioner** whose **Agency** is a party in interest to the transaction, submitted bid, submitted proposal, contract, lease, permit, or license shall convene a hearing, upon not less than five (5) **Days**' written notice to the parties involved to determine if any penalties should attach for the failure of a person to testify.

63.5 If any non-governmental party to the hearing requests an adjournment, the **Commissioner** who convened the hearing may, upon granting the adjournment, suspend any contract, lease, permit, or license, pending the final determination pursuant to Article 63.7 without the **City** incurring any penalty or damages for delay or otherwise.



63.6 The penalties which may attach after a final determination by the **Commissioner** may include but shall not exceed:

63.6.1 The disqualification for a period not to exceed five (5) years from the date of an adverse determination for any person, or any entity of which such person was a member at the time the testimony was sought, from submitting bids for, or transacting business with, or entering into or obtaining any contract, lease, permit or license with or from the **City**; and/or

63.6.2 The cancellation or termination of any and all such existing **City** contracts, leases, permits or licenses that the refusal to testify concerns and that have not been assigned as permitted under this **Contract**, nor the proceeds of which pledged, to an unaffiliated and unrelated institutional lender for fair value prior to the issuance of the notice scheduling the hearing, without the **City** incurring any penalty or damages on account of such cancellation or termination; monies lawfully due for goods delivered, work done, rentals, or fees accrued prior to the cancellation or termination shall be paid by the **City**.

63.7 The **Commissioner** shall consider and address in reaching his/her determination and in assessing an appropriate penalty the factors in Articles 63.7.1 and 63.7.2. The **Commissioner** may also consider, if relevant and appropriate, the criteria established in Articles 63.7.3 and 63.7.4, in addition to any other information which may be relevant and appropriate:

63.7.1 The party's good faith endeavors or lack thereof to cooperate fully and faithfully with any governmental investigation or audit, including but not limited to the discipline, discharge, or disassociation of any person failing to testify, the production of accurate and complete books and records, and the forthcoming testimony of all other members, agents, assignees or fiduciaries whose testimony is sought.

63.7.2 The relationship of the person who refused to testify to any entity that is a party to the hearing, including but not limited to, whether the person whose testimony is sought has an ownership interest in the entity and/or the degree of authority and responsibility the person has within the entity.

63.7.3 The nexus of the testimony sought to the subject entity and its contracts, leases, permits or licenses with the **City**.

63.7.4 The effect a penalty may have on an unaffiliated and unrelated party or entity that has a significant interest in an entity subject to penalties under Article 63.6, provided that the party or entity has given actual notice to the **Commissioner** upon the acquisition of the interest, or at the hearing called for in Article 63.4, gives notice and proves that such interest was previously acquired. Under either circumstance the party or entity shall present evidence at the hearing demonstrating the potential adverse impact a penalty will have on such person or entity.

63.8 Definitions:

63.8.1 The term "license" or "permit" as used in this Article 63 shall be defined as a license, permit, franchise or concession not granted as a matter of right.

63.8.2 The term "person" as used in this Article 63 shall be defined as any natural person doing business alone or associated with another person or entity as a partner, director, officer, principal or employee.

63.8.3 The term “entity” as used in this Article 63 shall be defined as any firm, partnership, corporation, association, joint venture, or person that receives monies, benefits, licenses, leases, or permits from or through the **City** or otherwise transacts business with the **City**.

63.8.4 The term “member” as used in this Article 63 shall be defined as any person associated with another person or entity as a partner, director, officer, principal or employee.

63.9 In addition to and notwithstanding any other provision of this **Contract**, the **Commissioner** may in his/her sole discretion terminate this **Contract** upon not less than three (3) **Days**’ written notice in the event the **Contractor** fails to promptly report in writing to the **Commissioner** of the Department of Investigations (“DOI”) of the **City** any solicitation of money, goods, requests for future employment or other benefit or thing of value, by or on behalf of any employee of the **City** or other person, firm, corporation or entity for any purpose which may be related to the procurement or obtaining of this **Contract** by the **Contractor**, or affecting the performance of this **Contract**.

#### **ARTICLE 64. TERMINATION BY THE CITY**

64.1 In addition to termination pursuant to any other article of this **Contract**, the **Commissioner** may, at any time, terminate this **Contract** by written notice to the **Contractor**. In the event of termination, the **Contractor** shall, upon receipt of such notice, unless otherwise directed by the **Commissioner**:

64.1.1 Stop **Work** on the date specified in the notice;

64.1.2 Take such action as may be necessary for the protection and preservation of the **City**’s materials and property;

64.1.3 Cancel all cancelable orders for material and equipment;

64.1.4 Assign to the **City** and deliver to the **Site** or another location designated by the **Commissioner**, any non-cancelable orders for material and equipment that is not capable of use except in the performance of this **Contract** and has been specifically fabricated for the sole purpose of this **Contract** and not incorporated in the **Work**;

64.1.5 Take no action which will increase the amounts payable by the **City** under this **Contract**.

64.2 In the event of termination by the **City** pursuant to this Article 64, payment to the **Contractor** shall be in accordance with Articles 64.2.1, 64.2.2 or 64.2.3, to the extent that each respective article applies.

64.2.1 Lump Sum Contracts or Items: On all lump sum **Contracts**, or on lump sum items in a **Contract**, the **City** will pay the **Contractor** the sum of the amounts described in Articles 64.2.1(a) and 64.2.1(b), less all payments previously made pursuant to this **Contract**. On lump sum **Contracts** only, the **City** will also pay the **Contractor** an additional sum as provided in Article 64.2.1(c).

64.2.1(a) For **Work** completed prior to the notice of termination, the **Contractor** shall be paid a pro rata portion of the lump sum bid amount, plus approved change orders, based upon the percent completion of the **Work**, as determined by the

**Commissioner.** For the purpose of determining the pro rata portion of the lump sum bid amount to which the **Contractor** is entitled, the bid breakdown submitted in accordance with Article 41 shall be considered, but shall not be dispositive. The **Commissioner's** determination hereunder shall be final, binding, and conclusive.

64.2.1(b) For non-cancelable material and equipment that is not capable of use except in the performance of this **Contract** and has been specifically fabricated for the sole purpose of this **Contract**, but not yet incorporated in the **Work**, the **Contractor** shall be paid the lesser of the following, less salvage value:

64.2.1(b)(i) The Direct Cost, as defined in Article 64.2.4; or

64.2.1(b)(ii) The fair and reasonable value, if less than Direct Cost, of such material and equipment, plus necessary and reasonable delivery costs.

64.2.1(b)(iii) In addition, the **Contractor** shall be paid five (5%) percent of the amount described in Article 64.2.1(b)(i) or Article 64.2.1(b)(ii), whichever applies.

64.2.1(c) Except as otherwise provided in Article 64.2.1(d), on all lump sum **Contracts**, the **Contractor** shall be paid the percentage indicated below applied to the difference between the total lump sum bid amount and the total of all payments made prior to the notice of termination plus all payments allowed pursuant to Articles 64.2.1(a) and 64.2.1(b):

64.2.1(c)(i) Five (5%) percent of the first five million (\$5,000,000) dollars; and

64.2.1(c)(ii) Three (3%) percent of any amount between five million (\$5,000,000) dollars and fifteen million (\$15,000,000) dollars; plus

64.2.1(c)(iii) One (1%) percent of any amount over fifteen million (\$15,000,000) dollars.

64.2.1(d) In the event the **City** terminates a lump sum **Contract** pursuant to this Article 64 within ninety (90) **Days** after registration of the **Contract** with the **Comptroller**, the **Contractor** shall be paid one (1%) percent of the difference between the lump sum bid amount and the total of all payments made pursuant to this Article 64.2.

64.2.2 Unit Price Contracts or Items: On all unit price **Contracts**, or on unit price items in a **Contract**, the **City** will pay the **Contractor** the sum of the amounts described in Articles 64.2.2(a) and 64.2.2(b), less all payments previously made pursuant to this **Contract**:

64.2.2(a) For all completed units, the unit price stated in the **Contract**, and

64.2.2(b) For units that have been ordered but are only partially completed, the **Contractor** will be paid:

64.2.2(b)(i) A pro rata portion of the unit price stated in the **Contract** based upon the percent completion of the unit and

64.2.2(b)(ii) For non-cancelable material and equipment, payment will be made pursuant to Article 64.2.1(b).

64.2.3 Time and Materials Contracts or Items Based on Time and Material Records: On all **Contracts** or items in a **Contract** where payment for the **Work** is based on time and material records, the **Contractor** shall be paid in accordance with Article 26, less all payments previously made pursuant to this **Contract**.

64.2.4 Direct Costs: Direct Costs as used in this Article 64.2 shall mean:

64.2.4(a) The actual purchase price of material and equipment, plus necessary and reasonable delivery costs,

64.2.4(b) The actual cost of labor involved in construction and installation at the **Site**, and

64.2.4(c) The actual cost of necessary bonds and insurance purchased pursuant to requirements of this **Contract** less any amounts that have been or should be refunded by the **Contractor's** sureties or insurance carriers.

64.2.4(d) Direct Costs shall not include overhead.

64.3 In no event shall any payments under this Article 64 exceed the **Contract** price for such items.

64.4 All payments pursuant to Article 64 shall be in the nature of liquidated damages and shall be accepted by the **Contractor** in full satisfaction of all claims against the **City**.

64.5 The **City** may deduct or set off against any sums due and payable pursuant to this Article 64, any deductions authorized by this **Contract** or by **Law** (including but not limited to liquidated damages) and any claims it may have against the **Contractor**. The **City's** exercise of the right to terminate the **Contract** pursuant to this Article 64 shall not impair or otherwise effect the **City's** right to assert any claims it may have against the **Contractor** in a plenary action.

64.6 Where the **Work** covered by the **Contract** has been substantially completed, as determined in writing by the **Commissioner**, termination of the **Work** shall be handled as an omission of **Work** pursuant to Articles 29 and 33, in which case a change order will be issued to reflect an appropriate reduction in the **Contract** sum, or if the amount is determined after final payment, such amount shall be paid by the **Contractor**.

#### **ARTICLE 65. CHOICE OF LAW, CONSENT TO JURISDICTION AND VENUE**

65.1 This **Contract** shall be deemed to be executed in the **City** regardless of the domicile of the **Contractor**, and shall be governed by and construed in accordance with the **Laws** of the State of New York and the **Laws** of the United States, where applicable.

65.2 The parties agree that any and all claims asserted against the **City** arising under this **Contract** or related thereto shall be heard and determined in the courts of the State of New York ("New York State Courts") located in the **City** and County of New York. To effect this **Contract** and intent, the **Contractor** agrees:

65.2.1 If the **City** initiates any action against the **Contractor** in Federal court or in a New York State Court, service of process may be made on the **Contractor** either in person, wherever such **Contractor** may be found, or by registered mail addressed to the **Contractor** at its address as set forth in this **Contract**, or to such other address as the **Contractor** may provide to the **City** in writing; and

65.2.2 With respect to any action between the **City** and the **Contractor** in a New York State Court, the **Contractor** hereby expressly waives and relinquishes any rights it might otherwise have:

65.2.2(a) To move to dismiss on grounds of forum non conveniens;

65.2.2(b) To remove to Federal Court; and

65.2.2(c) To move for a change of venue to a New York State Court outside New York County.

65.2.3 With respect to any action brought by the **City** against the **Contractor** in a Federal Court located in the **City**, the **Contractor** expressly waives and relinquishes any right it might otherwise have to move to transfer the action to a Federal Court outside the **City**.

65.2.4 If the **Contractor** commences any action against the **City** in a court located other than in the **City** and County of New York, upon request of the **City**, the **Contractor** shall either consent to a transfer of the action to a New York State Court of competent jurisdiction located in the **City** and County of New York or, if the Court where the action is initially brought will not or cannot transfer the action, the **Contractor** shall consent to dismiss such action without prejudice and may thereafter reinstate the action in a New York State Court of competent jurisdiction in New York County.

65.3 If any provision(s) of this Article 65 is held unenforceable for any reason, each and all other provision(s) shall nevertheless remain in full force and effect.

## **ARTICLE 66. PARTICIPATION IN AN INTERNATIONAL BOYCOTT**

66.1 The **Contractor** agrees that neither the **Contractor** nor any substantially owned affiliated company is participating or shall participate in an international boycott in violation of the provisions of the Federal Export Administration Act of 1979, as amended, or the regulations of the United States Department of Commerce (Commerce Department) promulgated thereunder.

66.2 Upon the final determination by the Commerce Department or any other agency of the United States as to, or conviction of the **Contractor** or a substantially-owned affiliated company thereof for participation in an international boycott in violation of the provisions of the Export Administration Act of 1979, as amended, or the regulations promulgated thereunder, the **Comptroller** may, at his/her option, render forfeit and void this **Contract**.

66.3 The **Contractor** shall comply in all respects, with the provisions of Section 6-114 of the Administrative Code and the rules and regulations issued by the **Comptroller** thereunder.

## **ARTICLE 67. LOCALLY BASED ENTERPRISE PROGRAM**

67.1 This **Contract** is subject to the requirements of Section 6-108.1 of the Administrative Code and regulations promulgated thereunder. No construction contract shall be awarded unless and until these requirements have been complied with in their entirety; however, compliance with this Article 67 is not required if the Agency sets Subcontractor Participation Goals for Minority- and Women-Owned Business Enterprises (M/WBEs).

67.2 Unless specifically waived by the **Commissioner** with the approval of the Division of Economic and Financial Opportunity of the **City** Department of Business Services, if any portion of the **Contract** is subcontracted, not less than ten (10%) percent of the total dollar amount of the **Contract** shall be awarded to locally based enterprises (LBEs); except that where less than ten (10%) percent of the total dollar amount of the **Contract** is subcontracted, such lesser percentage shall be so awarded.

67.3 The **Contractor** shall not require performance and payment bonds from LBE **Subcontractors**.

67.4 If the **Contractor** has indicated prior to award that no **Work** will be subcontracted, no **Work** shall be subcontracted without the prior approval of the **Commissioner**, which shall be granted only if the **Contractor** makes a good faith effort beginning at least six (6) weeks before the **Work** is to be performed to obtain LBE **Subcontractors** to perform the **Work**.

67.5 If the **Contractor** has not identified sufficient LBE **Subcontractors** prior to award, it shall sign a letter of compliance stating that it complies with Section 6-108.1 of the Administrative Code, recognizes that achieving the LBE requirement is a condition of its **Contract**, and shall submit documentation demonstrating its good faith efforts to obtain LBEs. After award, the **Contractor** shall begin to solicit LBE's to perform subcontracted **Work** at least six (6) weeks before the date such **Work** is to be performed and shall demonstrate that a good faith effort has been made to obtain LBEs on each subcontract until it meets the required percentage.

67.6 Failure of the **Contractor** to comply with the requirements of Section 6-108.1 of the Administrative Code and the regulations promulgated thereunder shall constitute a material breach of this **Contract**. Remedy for such breach may include the imposition of any or all of the following sanctions:

67.6.1 Reducing the **Contractor's** compensation by an amount equal to the dollar value of the percentage of the LBE subcontracting requirement not complied with;

67.6.2 Declaring the **Contractor** in default;

67.6.3 If the **Contractor** is an LBE, de-certifying and declaring the **Contractor** ineligible to participate in the LBE program for a period of up to three (3) years.

## **ARTICLE 68. ANTITRUST**

68.1 The **Contractor** hereby assigns, sells, and transfers to the **City** all right, title, and interest in and to any claims and causes of action arising under the antitrust **Laws** of New York State or of the United States relating to the particular goods or services purchased or procured by the **City** under this **Contract**.

## **ARTICLE 69. MacBRIDE PRINCIPLES PROVISIONS**

### 69.1 Notice To All Prospective **Contractors**:

69.1.1 Local Law No. 34 of 1991 became effective on September 10, 1991 and added Section 6-115.1 of the Administrative Code. The local **Law** provides for certain restrictions on **City Contracts** to express the opposition of the people of the **City** to employment discrimination practices in Northern Ireland to promote freedom of work-place opportunity.

69.1.2 Pursuant to Section 6-115.1, prospective **Contractors** for **Contracts** to provide goods or services involving an expenditure of an amount greater than ten thousand (\$10,000.) dollars, or for construction involving an amount greater than fifteen thousand (\$15,000.) dollars, are asked to sign a rider in which they covenant and represent, as a material condition of their **Contract**, that any business operations in Northern Ireland conducted by the **Contractor** and any individual or legal entity in which the **Contractor** holds a ten (10%) percent or greater ownership interest in the **Contractor** will be conducted in accordance with the MacBride Principles of nondiscrimination in employment.

69.1.3 Prospective **Contractors** are not required to agree to these conditions. However, in the case of **Contracts** let by competitive sealed bidding, whenever the lowest responsible bidder has not agreed to stipulate to the conditions set forth in this notice and another bidder who has agreed to stipulate to such conditions has submitted a bid within five (5%) percent of the lowest responsible bid for a **Contract** to supply goods, services or contraction of comparable quality, the **Agency** shall refer such bids to the Mayor, the Speaker or other officials, as appropriate, who may determine, in accordance with applicable **Law**, that it is in the best interest of the **City** that the **Contract** be awarded to other than the lowest responsible pursuant to Section 313(b)(2) of the **City** Charter.

69.1.4 In the case of **Contracts** let by other than competitive sealed bidding, if a prospective **Contractor** does not agree to these conditions, no **Agency**, elected official or the **City** Council shall award the **Contract** to that bidder unless the **Agency** seeking to use the goods, services or construction certifies in writing that the **Contract** is necessary for the **Agency** to perform its functions and there is no other responsible **Contractor** who will supply goods, services or construction of comparable quality at a comparable price.

69.2 In accordance with Section 6-115.1 of the Administrative Code, the **Contractor** stipulates that such **Contractor** and any individual or legal entity in which the **Contractor** holds a ten (10%) percent or greater ownership interest in the **Contractor** either:

69.2.1 Have no business operations in Northern Ireland, or

69.2.2 Shall take lawful steps in good faith to conduct any business operations they have in Northern Ireland in accordance with the MacBride Principles, and shall permit independent monitoring of their compliance with such principles.

69.3 For purposes of this Article, the following terms shall have the following meanings:

69.3.1 “MacBride Principles” shall mean those principles relating to nondiscrimination in employment and freedom of work-place opportunity which require employers doing business in Northern Ireland to:

69.3.1(a) increase the representation of individuals from under-represented religious groups in the workforce, including managerial, supervisory, administrative, clerical and technical jobs;

69.3.1(b) take steps to promote adequate security for the protection of employees from under-represented religious groups both at the work-place and while traveling to and from **Work**;

69.3.1(c) ban provocative religious or political emblems from the workplace;

69.3.1(d) publicly advertise all job openings and make special recruitment efforts to attract applicants from under-represented religious groups;

69.3.1(e) establish layoff, recall, and termination procedures which do not in practice favor a particular religious group;

69.3.1(f) abolish all job reservations, apprenticeship restrictions and different employment criteria which discriminate on the basis of religion;

69.3.1(g) develop training programs that will prepare substantial numbers of current employees from under-represented religious groups for skilled jobs, including the expansion of existing programs and the creation of new programs to train, upgrade, and improve the skills of workers from under-represented religious groups;

69.3.1(h) establish procedures to assess, identify, and actively recruit employees from under-represented religious groups with potential for further advancement; and

69.3.1(i) appoint a senior management staff member to oversee affirmative action efforts and develop a timetable to ensure their full implementation.

69.4 The **Contractor** agrees that the covenants and representations in Article 69.2 are material conditions to this **Contract**. In the event the **Agency** receives information that the **Contractor** who made the stipulation required by this Article 69 is in violation thereof, the **Agency** shall review such information and give the **Contractor** an opportunity to respond. If the **Agency** finds that a violation has occurred, the **Agency** shall have the right to declare the **Contractor** in default and/or terminate this **Contract** for cause and procure supplies, services or **Work** from another source in the manner the **Agency** deems proper. In the event of such termination, the **Contractor** shall pay to the **Agency**, or the **Agency** in its sole discretion may withhold from any amounts otherwise payable to the **Contractor**, the difference between the **Contract** price for the uncompleted portion of this **Contract** and the cost to the **Agency** of completing performance of this **Contract** either itself or by engaging another **Contractor** or **Contractors**. In the case of a requirement **Contract**, the **Contractor** shall be liable for such difference in price for the entire amount of supplies required by the **Agency** for the uncompleted term of **Contractor's Contract**. In the case of a construction **Contract**, the **Agency** shall also have the right to hold the **Contractor** in partial or total default in accordance with the default provisions of this **Contract**, and/or may seek debarment or suspension of the **Contractor**. The rights and remedies of the **Agency** hereunder shall be in addition to, and not in lieu of, any rights and remedies the **Agency** has pursuant to this **Contract** or by operation of **Law**.



## **ARTICLE 70. ELECTRONIC FILING/NYC DEVELOPMENT HUB**

70.1 The **Contractor** shall electronically file all alteration type-2 and alteration type-3 applications via the New York City Development Hub Web site, except applications for the following types of minor alterations: enlargements, curb cuts, legalizations, fire alarms, builders pavement plans, and jobs filed on Landmark Preservation Commission calendared properties. All such filings must be professionally certified. Information about electronic filing via the New York City Development Hub is available on the **City** Department of Buildings Web site at [www.nyc.gov/buildings](http://www.nyc.gov/buildings).

## **ARTICLE 71. PROHIBITION OF TROPICAL HARDWOODS**

71.1 Tropical hardwoods, as defined in Section 165 of the New York State Finance Law (Finance Law), shall not be utilized in the performance of this **Contract** except as expressly permitted by Section 165 of the Finance Law.

## **ARTICLE 72. CONFLICTS OF INTEREST**

72.1 Section 2604 of the **City** Charter and other related provisions of the **City** Charter, the Administrative Code, and the Penal Law are applicable under the terms of this **Contract** in relation to conflicts of interest and shall be extended to **Subcontractors** authorized to perform **Work**, labor and services pursuant to this **Contract** and further, it shall be the duty and responsibility of the **Contractor** to so inform its respective **Subcontractors**. Notice is hereby given that, under certain circumstances, penalties may be invoked against the donor as well as the recipient of any form of valuable gift.

## **ARTICLE 73. MERGER CLAUSE**

73.1 The written **Contract** herein, contains all the terms and conditions agreed upon by the parties hereto, and no other agreement, oral or otherwise, regarding the subject matter of this **Contract** shall be deemed to exist or to bind any of the parties hereto, or to vary any of the terms contained herein.

## **ARTICLE 74. STATEMENT OF WORK**

74.1 The **Contractor** shall furnish all labor and materials and perform all **Work** in strict accordance with the **Specifications** and **Addenda** thereto, numbered as shown in Schedule A.

## **ARTICLE 75. COMPENSATION TO BE PAID TO CONTRACTOR**

75.1 The **City** will pay and the **Contractor** will accept in full consideration for the performance of the **Contract**, subject to additions and deductions as provided herein, the total sum shown in Schedule A, this said sum being the amount at which the **Contract** was awarded to the **Contractor** at a public letting thereof, based upon the **Contractor's** bid for the **Contract**.

## **ARTICLE 76. ELECTRONIC FUNDS TRANSFER**

76.1 In accordance with Section 6-107.1 of the Administrative Code, the **Contractor** agrees to accept payments under this **Contract** from the **City** by electronic funds transfer (EFT). An EFT is any

transfer of funds, other than a transaction originated by check, draft or similar paper instrument, which is initiated through an electronic terminal, telephonic instrument or computer or magnetic tape so as to order, instruct or authorize a financial institution to debit or credit an account. Prior to the first payment made under this **Contract**, the **Contractor** shall designate one financial institution or other authorized payment agent and shall complete the attached “EFT Vendor Payment Enrollment Form” in order to provide the Commissioner of the **City** Department of Finance with information necessary for the **Contractor** to receive electronic funds transfer payments through a designated financial institution or authorized payment agent. The crediting of the amount of a payment to the appropriate account on the books of a financial institution or other authorized payment agent designated by the **Contractor** shall constitute full satisfaction by the **City** for the amount of the payment under this **Contract**. The account information supplied by the **Contractor** to facilitate the electronic funds transfer shall remain confidential to the fullest extent provided by **Law**.

76.2 The **Commissioner** may waive the application of the requirements of this Article 76 to payments on contracts entered into pursuant to Section 315 of the **City** Charter. In addition, the Commissioner of the Department of Finance and the Comptroller may jointly issue standards pursuant to which the **Agency** may waive the requirements of this Article 76 for payments in the following circumstances: (i) for individuals or classes of individuals for whom compliance imposes a hardship; (ii) for classifications or types of checks; or (iii) in other circumstances as may be necessary in the interest of the **City**.

#### **ARTICLE 77. RECORDS RETENTION**

77.1 The **Contractor** agrees to retain all books, records, and other documents relevant to this **Contract** for six years after the final payment or termination of this **Contract**, whichever is later. **City**, state, and federal auditors and any other persons duly authorized by the **City** shall have full access to and the right to examine any such books, records, and other documents during the retention period.

#### **ARTICLE 78. EXAMINATION AND VIEWING OF SITE, CONSIDERATION OF OTHER SOURCES OF INFORMATION AND CHANGED SITE CONDITIONS**

78.1 Pre-Bidding (Investigation) Viewing of Site – Bidders must carefully view and examine the **Site** of the proposed **Work**, as well as its adjacent area, and seek other usual sources of information, for they will be conclusively presumed to have full knowledge of any and all conditions and hazards on, about or above the **Site** relating to or affecting in any way the performance of the **Work** to be done under the **Contract** that were or should have been known by a reasonably prudent bidder. To arrange a date for visiting the **Site**, bidders are to contact the **Agency** contact person specified in the bid documents.

78.2 Should the **Contractor** encounter during the progress of the **Work** site conditions or environmental hazards at the **Site** materially differing from any shown on the **Contract Drawings** or indicated in the **Specifications** or such conditions or environmental hazards as could not reasonably have been anticipated by the **Contractor**, which conditions or hazards will materially affect the cost of the **Work** to be done under the **Contract**, the attention of the **Commissioner** must be called immediately to such conditions or hazards before they are disturbed. The **Commissioner** shall thereupon promptly investigate the conditions or hazards. If the **Commissioner** finds that they do so materially differ, and that they could not have been reasonably anticipated by the **Contractor**, the **Contract** may be modified with the **Commissioner**'s written approval.

SIGNATURE OF THE CONTRACT

**IN WITNESS WHEREOF**, the Commissioner, on behalf of the City of New York and the Contractor, have executed **FIVE COPIES** of this contract, **three parts of which are to remain with the Commissioner, one other to be filed with the Comptroller of the City, and the fifth to be delivered to the Contractor.**

THE CITY OF NEW YORK

BY \_\_\_\_\_  
COMMISSIONER

\_\_\_\_\_  
NAME OF CONTRACTOR

BY \_\_\_\_\_  
AUTHORIZED OFFICER OF THE FIRM OR CORPORATION

(Where Contractor is a Corporation, add):  
Attest:

\_\_\_\_\_  
SECRETARY (Seal)

**BLANK PAGE**

**ACKNOWLEDGMENT BY CORPORATION**

State of \_\_\_\_\_, County of \_\_\_\_\_ ss:

On this \_\_\_\_\_ day of \_\_\_\_\_,

before me personally came \_\_\_\_\_

who affirms or being by me duly sworn, did depose and say that he/she resides in

the City of \_\_\_\_\_; that he/she is the \_\_\_\_\_

of the \_\_\_\_\_ the corporation described in and which executed the foregoing instrument; that he knows the seal of said corporation, that the seal affixed to the said instrument is such corporate seal; that it was so affixed by order of the Board of Directors of said corporation; and that he/she signed his name thereto by like order.

\_\_\_\_\_  
Notary Public or Commissioner of Deeds

**ACKNOWLEDGMENT BY COMMISSIONER**

State of New York, County of Queens ss:

On this \_\_\_\_\_ day of \_\_\_\_\_,

before me personally came \_\_\_\_\_

to me known and known to me to be the \_\_\_\_\_ Commissioner of the Department Environmental Protection of the City of New York, the person described as such in and who as such executed the foregoing instrument and he/she acknowledged to me that he/she executed the same as Commissioner for the purposes therein mentioned.

\_\_\_\_\_  
Notary Public or Commissioner of Deeds

**BLANK PAGE**

**ACKNOWLEDGMENT BY PARTNERSHIP**

State of \_\_\_\_\_, County of \_\_\_\_\_ ss:

On this \_\_\_\_\_ day of \_\_\_\_\_, \_\_\_\_\_

before me personally came \_\_\_\_\_, to be known

and known to me to be a member of \_\_\_\_\_, the firm described in and which executed the foregoing instrument and he/she acknowledged to me that he/she subscribed the name of said firm thereto on behalf of said firm for the purposes therein mentioned.

\_\_\_\_\_  
Notary Public or Commissioner of Deeds

**ACKNOWLEDGMENT BY INDIVIDUAL**

State of \_\_\_\_\_, County of \_\_\_\_\_ ss:

On this \_\_\_\_\_ day of \_\_\_\_\_, \_\_\_\_\_

before me personally came \_\_\_\_\_

to me known and known to me to be the same person described and who executed the foregoing instrument and he/she acknowledged to me that he/she executed the same for the purposes therein mentioned

\_\_\_\_\_  
Notary Public or Commissioner of Deeds

**BLANK PAGE**



**AUTHORITY**

MAYOR'S CERTIFICATE NO. CBX \_\_\_\_\_ DATED \_\_\_\_\_

BUDGET DIRECTOR'S CERTIFICATE NO. CP/CAS \_\_\_\_\_ DATED \_\_\_\_\_

**APPROPRIATION**

COMMISSIONER'S CERTIFICATE

In conformity with the provisions of Section 6-101 of the Administrative Code of the City of New York, it is hereby certified that the estimated cost of the work, materials and supplies required by the within Contract, amounting to:

\_\_\_\_\_  
\$ \_\_\_\_\_

is chargeable to the fund of the Department of Environmental Protection Budget Code(s):

\_\_\_\_\_  
\_\_\_\_\_

I hereby certify that the specifications contained herein comply with the terms and conditions of the FY \_\_\_\_\_ BUDGET.

\_\_\_\_\_  
Commissioner of the Department of Environmental Protection

**COMPTROLLER'S CERTIFICATE**

The City of New York \_\_\_\_\_, \_\_\_\_\_

In pursuance of the provisions of Section 6-101 of the Administrative Code of the City of New York, I hereby certify that there remains unapplied and unexpended a balance of the above mentioned fund applicable to this Contract sufficient to pay the estimated expense of executing the same, viz.:

\$ \_\_\_\_\_.

\_\_\_\_\_  
Comptroller

**BLANK PAGE**

# Performance Bond Greater Than \$5 Million

## PERFORMANCE BOND

**KNOW ALL PEOPLE BY THESE PRESENTS:,**

That we, \_\_\_\_\_

---

---

hereinafter referred to as the "Principal,"

and, \_\_\_\_\_

---

---

hereinafter referred to as the "Surety" ("Sureties") are held and firmly bound to THE CITY OF NEW YORK, hereinafter referred to as the "City" or to its successors and assigns in the penal sum of \_\_\_\_\_

---

---

(\$ \_\_\_\_\_ ) Dollars, lawful money of the United States for the payment of which said sum of money well and truly to be made, we, and each of us, bind ourselves, our heirs, executors, administrators, successors and assigns, jointly and severally, firmly by these presents.

**WHEREAS,** The Principal is about to enter, or has entered, into a Contract in writing with the City for

---

---

a copy of which Contract is annexed to and hereby made a part of this bond as though herein set forth in full;

**NOW, THEREFORE,** the conditions of this obligation are such that if the Principal, his or its representatives or assigns, shall well and faithfully perform the said Contract and all modifications, amendments, additions and alterations thereto that may hereafter be made, according to its terms and its true intent and meaning, including repair and or replacement of defective work and guarantees of maintenance for the periods stated in the Contract, and shall fully indemnify and save harmless the City from all cost and damage which it may suffer by reason of the Principal's default of the Contract, and shall fully reimburse and repay the City for all outlay and expense which the City may incur in making

## Performance Bond Greater Than \$5 Million

good any such default and shall protect the said City of New York against, and pay any and all amounts, damages, cost and judgments which may or shall be recovered against said City or its officers or agents or which the said City of New York may be called upon to pay any person or corporation by reason of any damages arising or growing out of the Principal's default of the Contract, then this obligation shall be null and void, otherwise to remain in full force and effect.

The Surety (Sureties), for value received, hereby stipulates and agrees, upon written notice from the City that the City has determined that the Principal is in default of the Contract, to either (1) pay the full amount of the above penal sum in complete discharge and exoneration of this bond and of all the liabilities of the Surety relating to this bond, or (2) fully perform and complete the Work to be performed under the Contract, pursuant to the terms, conditions, and covenants thereof. The Surety (Sureties) further agrees, at its option, either to tender the penal sum or to commence and diligently perform the Work specified in the Contract, including physical site work, within twenty-five (25) business days after written notice thereof from the City and to complete all Work within the time set forth in the Contract or such other time as agreed to between the City and Surety in accordance with the Contract. The Surety and the City reserve all rights and defenses each may have against the other; provided, however, that the Surety expressly agrees that its reservation of rights shall not provide a basis for non-performance of its obligation to commence and to complete all Work as provided herein.

The Surety (Sureties), for value received, for itself and its successors and assigns, hereby stipulates and agrees that the obligation of said Surety (Sureties) and its bond shall be in no way impaired or affected by any extension of time, modification, omission, addition, or change in or to the said Contract or the Work to be performed thereunder, or by any payment thereunder before the time required therein, or by any waiver of any provisions thereof, or by any assignment, subletting or other transfer thereof or of any Work to be performed or any moneys due or to become due thereunder; and said Surety (Sureties) does hereby waive notice of any and all of such extensions, modifications, omissions, additions, changes, payments, waivers, assignments, subcontracts and transfers, and hereby expressly stipulates and agrees that any and all things done and omitted to be done by and in relation to assignees, subcontractors, and other transferees shall have the same effect as to said Surety (Sureties) as though done or omitted to be done by or in relation to said Principal.

**IN WITNESS WHEREOF**, The Principal and the Surety (Sureties) have hereunto set their hands and seals, and such of them as are corporations have caused their corporate seals to be hereunto affixed and these presents to be signed by their proper officers, this

\_\_\_\_\_ day of \_\_\_\_\_ 20\_\_\_\_ .  
(Seal)

\_\_\_\_\_ (L.S.)

Principal

By \_\_\_\_\_.

(Seal)

Surety

By \_\_\_\_\_.

# Performance Bond Greater Than \$5 Million

(Seal) \_\_\_\_\_  
Surety

By \_\_\_\_\_

(Seal) \_\_\_\_\_  
Surety

By \_\_\_\_\_

(Seal) \_\_\_\_\_  
Surety

By \_\_\_\_\_

(Seal) \_\_\_\_\_  
Surety

By \_\_\_\_\_

Bond Premium Rate \_\_\_\_\_.

Bond Premium Cost \_\_\_\_\_.

If the Contractor (Principal) is a partnership, the bond should be signed by each of the individuals who are partners.

If the Contractor (Principal) is a corporation, the bond should be signed in its correct corporate name by a duly authorized officer, agent, or attorney-in-fact.

There should be executed an appropriate number of counterparts of the bond corresponding to the number of counterparts of the Contract.

# Performance Bond Greater Than \$5 Million

## ACKNOWLEDGMENT OF PRINCIPAL IF A CORPORATION

State of \_\_\_\_\_ County of \_\_\_\_\_ ss:

On this \_\_\_\_\_ day of \_\_\_\_\_ 20 \_\_\_\_\_ before me personally came \_\_\_\_\_,  
to me known, who, being by me duly sworn did depose and say that he/she resides  
at \_\_\_\_\_

\_\_\_\_\_ ; that he/she is the \_\_\_\_\_  
of \_\_\_\_\_ the corporation described in and which executed the foregoing instrument; and that he signed his  
name to the foregoing instrument by order of the directors of said corporation as the duly authorized and  
binding act thereof.

\_\_\_\_\_  
Notary Public or Commissioner of Deeds.

## ACKNOWLEDGMENT OF PRINCIPAL IF A PARTNERSHIP

State of \_\_\_\_\_ County of \_\_\_\_\_ ss:

On this \_\_\_\_\_ day of \_\_\_\_\_ 20 \_\_\_\_\_ before me personally came \_\_\_\_\_  
to me known, who, being by me duly sworn did depose and say that he/she resides  
at \_\_\_\_\_

\_\_\_\_\_ ; that he/she is \_\_\_\_\_ partner of  
\_\_\_\_\_, a limited/general partnership existing under the laws of the State of  
\_\_\_\_\_, the partnership described in and which executed the foregoing instrument;  
and that he/she signed his/her name to the foregoing instrument as the duly authorized and binding act of  
said partnership.

\_\_\_\_\_  
Notary Public or Commissioner of Deeds.

# Performance Bond Greater Than \$5 Million

## ACKNOWLEDGMENT OF PRINCIPAL IF AN INDIVIDUAL

State of \_\_\_\_\_ County of \_\_\_\_\_ ss:

On this \_\_\_\_\_ day of \_\_\_\_\_ 20 \_\_\_\_\_ before me personally  
came \_\_\_\_\_  
to me known, who, being by me duly sworn did depose and say that he/she resides  
at \_\_\_\_\_

\_\_\_\_\_, and that he/she is the individual whose name is  
subscribed to the within instrument and acknowledged to me that by his/her signature on the  
instrument, said individual executed the instrument.

\_\_\_\_\_  
Notary Public or Commissioner of Deeds.

Affix Acknowledgments and justification of Sureties

**BLANK PAGE**



**PERFORMANCE BOND**

**KNOW ALL PEOPLE BY THESE PRESENTS:,**

That we, \_\_\_\_\_

\_\_\_\_\_  
\_\_\_\_\_

hereinafter referred to as the "Principal,"  
and, \_\_\_\_\_

\_\_\_\_\_  
\_\_\_\_\_

hereinafter referred to as the "Surety" ("Sureties") are held and firmly bound to THE CITY OF NEW YORK, hereinafter referred to as the "City" or to its successors and assigns in the penal sum of \_\_\_\_\_

\_\_\_\_\_  
\_\_\_\_\_

(\$ \_\_\_\_\_ ) Dollars, lawful money of the United States for the payment of which said sum of money well and truly to be made, we, and each of us, bind ourselves, our heirs, executors, administrators, successors and assigns, jointly and severally, firmly by these presents.

**WHEREAS,** The Principal is about to enter, or has entered, into a Contract in writing with the City for

\_\_\_\_\_  
\_\_\_\_\_

a copy of which Contract is annexed to and hereby made a part of this bond as though herein set forth in full;

**NOW, THEREFORE,** the conditions of this obligation are such that if the Principal, his or its representatives or assigns, shall well and faithfully perform the said Contract and all modifications, amendments, additions and alterations thereto that may hereafter be made, according to its terms and its true intent and meaning, including repair and or replacement of defective work and guarantees of maintenance for the periods stated in the Contract, and shall fully indemnify and save harmless the City from all cost and damage which it may suffer by reason of the Principal's default of the Contract, and shall fully reimburse and repay the City for all outlay and expense which the City may incur in making

good any such default and shall protect the said City of New York against, and pay any and all amounts, damages, cost and judgments which may or shall be recovered against said City or its officers or agents or which the said City of New York may be called upon to pay any person or corporation by reason of any damages arising or growing out of the Principal's default of the Contract, then this obligation shall be null and void, otherwise to remain in full force and effect.

The Surety (Sureties), for value received, hereby stipulates and agrees, upon written notice from the City that the City has determined that the Principal is in default of the Contract, to (1) pay the City the cost to complete the contract as determined by the City in excess of the balance of the Contract held by the City, plus any damages or costs to which the City is entitled, up to the full amount of the above penal sum, (2) fully perform and complete the Work to be performed under the Contract, pursuant to the terms, conditions, and covenants thereof, or (3) tender a completion Contractor that is acceptable to the City. The Surety (Sureties) further agrees, at its option, either to notify the City that it elects to pay the city the cost of completion plus any applicable damages and costs under option (1) above, or to commence and diligently perform the Work specified in the Contract, including physical site work, within twenty-five (25) business days after written notice thereof from the City and, if the Surety elects to fully perform and complete the Work, then to complete all Work within the time set forth in the Contract or such other time as agreed to between the City and Surety in accordance with the Contract. If the Surety elects to tender payment pursuant to (1) above, then the Surety shall tender such amount within fifteen (15) business days notification from the City of the cost of completion. The Surety and the City reserve all rights and defenses each may have against the other; provided, however, that the Surety expressly agrees that its reservation of rights shall not provide a basis for non-performance of its obligation to pay the City the cost of completion, to commence and complete all Work as provided herein, or to tender a completion contractor.

The Surety (Sureties), for value received, for itself and its successors and assigns, hereby stipulates and agrees that the obligation of said Surety (Sureties) and its bond shall be in no way impaired or affected by any extension of time, modification, omission, addition, or change in or to the said Contract or the Work to be performed thereunder, or by any payment thereunder before the time required therein, or by any waiver of any provisions thereof, or any moneys due or to become due thereunder; and said Surety (Sureties) does hereby waive notice of any and all of such extensions, modifications, omissions, additions, changes, payments, and waivers, and hereby expressly stipulates and agrees that any and all things done and omitted to be done by and in relation to subcontractors shall have the same effect as to said Surety (Sureties) as though done or omitted to be done by or in relation to said Principal. Notwithstanding the above, if the City makes payments to the Principal before the time required by the contract that in the aggregate exceed \$100,000 or 10% of the Contract price, whichever is less, and that have not become earned prior to the Principal being found to be in default, then all payments made to the Principal before the time required by the Contract shall be added to the remaining contract value available to be paid for the completion of the Contract as if such sums had not been paid to the Principal, but shall not provide a basis for non-performance of its obligation to pay the City the cost of completion, to commence and to complete all Work as provided herein, or to tender a completion contractor

**IN WITNESS WHEREOF**, The Principal and the Surety (Sureties) have hereunto set their hands and seals, and such of them as are corporations have caused their corporate seals to be hereunto affixed and these presents to be signed by their proper officers, this

\_\_\_\_\_ day of \_\_\_\_\_ 20 \_\_\_\_\_ .  
(Seal)

\_\_\_\_\_  
Principal (L.S.)

(Seal) By \_\_\_\_\_  
Surety

(Seal) By \_\_\_\_\_  
Surety

(Seal) By \_\_\_\_\_  
Surety

(Seal) By \_\_\_\_\_  
Surety

(Seal) By \_\_\_\_\_  
Surety

By \_\_\_\_\_

Bond Premium Rate \_\_\_\_\_

Bond Premium Cost \_\_\_\_\_

If the Contractor (Principal) is a partnership, the bond should be signed by each of the individuals who are partners.

If the Contractor (Principal) is a corporation, the bond should be signed in its correct corporate name by a duly authorized officer, agent, or attorney-in-fact.

There should be executed an appropriate number of counterparts of the bond corresponding to the number of counterparts of the Contract.

**ACKNOWLEDGMENT OF PRINCIPAL IF A CORPORATION**

State of \_\_\_\_\_ County of \_\_\_\_\_ ss:

On this \_\_\_\_\_ day of \_\_\_\_\_ 20 \_\_\_\_\_ before me personally came \_\_\_\_\_, to me known, who, being by me duly sworn did depose and say that he/she resides at \_\_\_\_\_

\_\_\_\_\_ ; that he/she is the \_\_\_\_\_ of \_\_\_\_\_ the corporation described in and which executed the foregoing instrument; and that he signed his name to the foregoing instrument by order of the directors of said corporation as the duly authorized and binding act thereof.

\_\_\_\_\_  
Notary Public or Commissioner of Deeds.

**ACKNOWLEDGMENT OF PRINCIPAL IF A PARTNERSHIP**

State of \_\_\_\_\_ County of \_\_\_\_\_ ss:

On this \_\_\_\_\_ day of \_\_\_\_\_ 20 \_\_\_\_\_ before me personally came \_\_\_\_\_, to me known, who, being by me duly sworn did depose and say that he/she resides at \_\_\_\_\_

\_\_\_\_\_ ; that he/she is \_\_\_\_\_ partner of \_\_\_\_\_, a limited/general partnership existing under the laws of the State of \_\_\_\_\_, the partnership described in and which executed the foregoing instrument; and that he/she signed his/her name to the foregoing instrument as the duly authorized and binding act of said partnership.

\_\_\_\_\_  
Notary Public or Commissioner of Deeds.

**ACKNOWLEDGMENT OF PRINCIPAL IF AN INDIVIDUAL**

State of \_\_\_\_\_ County of \_\_\_\_\_ ss:

On this \_\_\_\_\_ day of \_\_\_\_\_ 20 \_\_\_\_\_ before me personally came \_\_\_\_\_  
to me known, who, being by me duly sworn did depose and say that he/she resides  
at \_\_\_\_\_,  
\_\_\_\_\_ and that he/she is the individual whose name is  
subscribed to the within instrument and acknowledged to me that by his/her signature on the  
instrument, said individual executed the instrument.

\_\_\_\_\_  
Notary Public or Commissioner of Deeds.

Affix Acknowledgments and justification of Sureties

**BLANK PAGE**

**PAYMENT BOND**

**KNOW ALL PERSONS BY THESE PRESENTS, That we,**

\_\_\_\_\_  
\_\_\_\_\_  
\_\_\_\_\_

**hereinafter referred to as the "Principal" and**

\_\_\_\_\_  
\_\_\_\_\_

**hereinafter referred to as the "Surety" ("Sureties") are held and firmly bound to THE CITY OF NEW YORK, hereinafter referred to as the "City" or to its successors and assigns, in the penal sum of:**

\_\_\_\_\_

**\$ \_\_\_\_\_ .**

**lawful money of the United States, for the payment of which said sum of money well and truly to be made, we, and each of us, bind ourselves, our heirs, executors, administrators, successors and assigns, jointly and severally, firmly by these presents.**

**WHEREAS, the Principal is about to enter, or has entered, into a Contract in writing with the City for:**

\_\_\_\_\_  
\_\_\_\_\_  
\_\_\_\_\_  
\_\_\_\_\_

**a copy of which Contract is annexed to and hereby made a part of this bond as though herein set forth in full.**

**PAYMENT BOND**

**NOW, THEREFORE, the conditions of this obligation are such that if the Principal, his or its representatives or assigns and other Subcontractors to whom Work under this Contract is sublet and his or their successors and assigns shall promptly pay or cause to be paid all lawful claims for:**

- a) Wages and compensation for labor performed and services rendered by all persons engaged in the prosecution of the Work under said Contract, and any amendment or extension thereof or addition thereto, whether such persons be agents, servants or employees of the Principal or of any such Subcontractors, including all persons so engaged who perform the work of laborers or mechanics at or in the vicinity of the site of the Project regardless of any Contractual relationship between the Principal or such Subcontractors, or his or their successors or assigns, on the one hand and such laborers or mechanics on the other, but not including office employees not regularly stationed at the site of the Project, and**
- b) Materials and supplies (whether incorporated in the permanent (construction or not), as well as teams, fuels, oils, implements or machinery furnished, used or consumed by said Principal or any Subcontractors at or in the vicinity of the site of the Project in the prosecution of the Work under said Contract and any amendment or extension thereof or addition thereto; then this obligation shall be null and void; otherwise to remain in full force and effect. This bond is subject to the following additional conditions, limitations and agreements:**
- c) The Principal and Surety (Sureties) agree that this bond shall be for the benefit of any materialman or laborer having a just claim, as well as the City itself.**
- d) All persons who have performed labor, rendered services or furnished materials and supplies, as aforesaid, shall have a direct right of action against the Principal and his, its or their successors and assigns, and the Surety (Sureties) herein, or against either or both or any of them and their successors and assigns. Such persons may sue in their own name, and may prosecute the suit to judgment and execution without the necessity of joining with any other person as party plaintiff.**
- e) The Principal and Surety (Sureties) agree that neither of them will hold the City liable for any judgment for costs or otherwise, obtained against either or both of them by a laborer or materialman in a suit brought by either a laborer or materialman under this bond for moneys allegedly due for performing work or furnishing material.**
- f) The Surety (Sureties) or its successors and assigns shall not be liable for any compensation recoverable by an employee or laborer under the Workmen's Compensation Law.**



## PAYMENT BOND

**g) In no event shall the Surety (Sureties), or its successors or assigns, be liable for a greater sum than the penalty of this bond or be subject to any suit, action or proceeding hereon that is instituted by any person, firm, or corporation hereunder later than two years after the complete performance of said Contract and final settlement thereof.**

**The Principal, for himself/herself and his successors and assigns, and the Surety (Sureties), for itself and its successors and assigns, do hereby expressly waive any objection that might be interposed as to the right of the City to require a bond containing the foregoing provisions, and they do hereby further expressly waive any defense which they or either of them might interpose to an action brought hereon by any person, firm or corporation, including Subcontractors, MATERIALMAN and third persons, for work, labor, services, supplies or material performed, rendered, or furnished as aforesaid upon the ground that there is no law authorizing the City to require the foregoing provisions to be placed in this bond.**

**And the Surety (Sureties) for value received, for itself and its successors and assigns, hereby stipulates and agrees that the obligation of said Surety (Sureties) and its bond shall be in no way impaired or affected by any extension of time, modification, omission, addition, or change in or of the said Contract or the Work to be performed thereunder, or by any payment thereunder before the time required therein, or by any waiver of any provisions thereof, or by any assignment, subletting or other transfer thereof or of any part thereof, or of any Work to be performed, or any moneys due or to become due thereunder; and said Surety (Sureties) does hereby waive notice of any and all of such extensions, modifications, omissions, additions, changes, payments, waivers, assignments, subcontracts and transfers, and hereby expressly stipulates and agrees that any and all things done and omitted to be done by and in relation to assignees, Subcontractors, and other transferees shall have the same effect as to said Surety (Sureties) as though done or omitted to be done by or in relation to said Principal.**

**PAYMENT BOND**

**IN WITNESS WHEREOF, the Principal and the Surety (Sureties) have hereunto set their hands and seals, and such of them as are corporations have caused their corporate seals to be hereunto affixed and these presents to be signed by their proper officers, this \_\_\_\_\_ day of \_\_\_\_\_, \_\_\_\_\_.**

(SEAL) \_\_\_\_\_ (L.S.)  
Principal  
By: \_\_\_\_\_

(SEAL) \_\_\_\_\_  
Surety  
By: \_\_\_\_\_

(SEAL) \_\_\_\_\_  
Surety  
By: \_\_\_\_\_

(SEAL) \_\_\_\_\_  
Surety  
By: \_\_\_\_\_

(SEAL) \_\_\_\_\_  
Surety  
By: \_\_\_\_\_

**BOND PREMIUM RATE:** \_\_\_\_\_

**BOND PREMIUM COST:** \_\_\_\_\_

**If the Contractor (Principal) is a partnership, the bond should be signed by each of the individuals who are partners. If the Contractor (Principal) is a corporation, the bond should be signed in its correct corporate name by a duly authorized officer, agent, or attorney-in-fact. There should be executed an appropriate member of counterparts of the bond corresponding to the number of counterparts of the Contract.**

**PAYMENT BOND**

**ACKNOWLEDGMENT OF PRINCIPAL - IF A CORPORATION**

State of \_\_\_\_\_ County of \_\_\_\_\_ ss:

On this \_\_\_\_\_ day of \_\_\_\_\_, \_\_\_\_\_

before me personally came \_\_\_\_\_

to me known, who, affirms or being by me duly sworn did depose and say that he/she resides

at \_\_\_\_\_  
\_\_\_\_\_

that he/she is the \_\_\_\_\_ of \_\_\_\_\_  
the corporation described in and which executed the foregoing instrument; that he/she knows the  
seal of said corporation; that one of the seals affixed to said instrument is such seal; that it was  
so affixed by order of the directors of said corporation, and that he/she signed his name thereto  
by like order.

\_\_\_\_\_  
Notary Public or Commissioner of Deeds

**ACKNOWLEDGMENT OF PRINCIPAL - IF A PARTNERSHIP**

State of \_\_\_\_\_ County of \_\_\_\_\_ ss.:

On this \_\_\_\_\_ day of \_\_\_\_\_, \_\_\_\_\_

before me personally appeared \_\_\_\_\_

to me known and known to me to be one of the members of the firm

of: \_\_\_\_\_  
described in and who executed the foregoing instrument and he/she acknowledged to me that  
he/she executed the same as and for the act and deed of said firm.

\_\_\_\_\_  
Notary Public or Commissioner of Deeds

**PAYMENT BOND**

**ACKNOWLEDGMENT OF PRINCIPAL - IF AN INDIVIDUAL**

State of \_\_\_\_\_ County of \_\_\_\_\_ SS.:

On this \_\_\_\_\_ day of \_\_\_\_\_ , \_\_\_\_\_

before me personally appeared \_\_\_\_\_ me known and known to me to be the

person described in and who executed the foregoing instrument and acknowledged that he/she executed

the same.

\_\_\_\_\_  
Notary Public or Commissioner of Deeds

Each executed bond should be accompanied by:

- a) appropriate acknowledgments of the respective parties;
- b) appropriate duly certified copy of Power of Attorney or other certificate of authority where bond is executed by agent, officer or other representative of Principal or Surety;
- c) a duly certified extract from By-Laws or resolutions of Surety under which Power of Attorney or other certificate of authority of its agent, officer or representative was issued; and
- d) duly certified copy of latest published financial statement of assets and liabilities of Surety.

\*\*\*\*\*

**AFFIX ACKNOWLEDGMENTS AND JUSTIFICATIONS OF SURETIES**



## **REMAINDER OF THIS CONTRACT DOCUMENT**

- TABLE OF CONTENTS
- SCHEDULE OF WAGE RATES
- GENERAL CONDITIONS (INCLUDING SCHEDULE "A")
- GENERAL SPECIFICATIONS
- DETAILED SPECIFICATIONS

**NO TEXT ON THIS PAGE**

**CITY OF NEW YORK  
DEPARTMENT OF ENVIRONMENTAL PROTECTION  
BUREAU OF ENGINEERING DESIGN & CONSTRUCTION**

**WATERFOWL MANAGEMENT PROGRAM BUILDING AND PAVING  
CONTRACT CRO-557G, H, P, E**

---

**TABLE OF CONTENTS**

---

New York State Schedule of Prevailing Wages for Westchester County .....1

**GENERAL CONDITIONS**

<b><u>ARTICLE</u></b>		<b><u>PAGE</u></b>
1.	Scope and Intent.....	83
2.	Provisions Referenced with Information for Bidders and the City of New York Standard Construction Contract.....	85
	(A) Schedule “A” and Liquidated Damages .....	85
	(B) Federal Excise Tax .....	85
	(C) Labor.....	85
	(D) Partial Payments for Materials in Advance of Their Incorporation in the Work Pursuant to Article 42 of the City of New York Standard Construction Contract .....	85
	(E) Conflicts of Interest .....	88
3.	Contract Drawings and Specifications.....	88
4.	Temporary Structures.....	90
5.	Contractor’s Superintendent .....	90
6.	Surveys.....	91
7.	Contractor’s Daily Reports .....	91
8.	Contractor’s Plant .....	91
9.	Security Guards and Fire Guards on the Site.....	92
10.	Certificates of Occupancy and/or Completion.....	92
11.	Coordination Among Contractors.....	93
12.	Public Dissemination of Information.....	94

**GENERAL SPECIFICATIONS**

<b><u>SECTION</u></b>	<b><u>DESCRIPTION</u></b>	<b><u>PAGE</u></b>
<b>DIVISION 2</b>	<b>SITE CONSTRUCTION</b>	
02105	Soil Sampling and Analysis.....	135
02222	Demolition and Removals.....	153
02230	Site Clearing.....	165
02240	Dewatering.....	179
02316	Excavation.....	191

**WATERFOWL MANAGEMENT PROGRAM BUILDING AND PAVING  
CONTRACT CRO-557G, H, P, E**

**TABLE OF CONTENTS (Continued)**

**GENERAL SPECIFICATIONS**

<b><u>SECTION</u></b>	<b><u>DESCRIPTION</u></b>	<b><u>PAGE</u></b>
02317	Backfilling.....	211
02318	Rock Excavation .....	227
02371	Dust, Soil Erosion and Sedimentation Control .....	231
02372	Embankment and Channel Protection.....	243
02461	Steel Sheet Piling.....	255
02501	Reinforced Concrete Sewer Pipe .....	265
02502	Vitrified Clay Pipe Sewers.....	277
02504	Sanitary and Storm Sewer Structures .....	283
02505	Leakage Tests.....	291
02741	Asphaltic Concrete Pavements .....	299
02771	Concrete Curbs, Headers and Sidewalks .....	317
02821	Metal Fence.....	323
02841	Guide Railing.....	339
02910	Planting .....	347
02920	Soil Mixes .....	375
 <b>DIVISION 3 CONCRETE</b>		
03100	Concrete Formwork .....	391
03210	Reinforcing Steel .....	405
03290	Joints in Concrete.....	421
03300	Cast-in-Place Concrete.....	437
03350	Concrete Finishes.....	519
03600	Grout .....	529
 <b>DIVISION 4 MASONRY</b>		
04051	Mortar and Masonry Grout .....	537
04400	Stone Masonry Units.....	545
 <b>DIVISION 5 METALS</b>		
05081	Galvanizing .....	553
05091	Welding.....	559
05092	Metal Fastening.....	569
05120	Structural Steel.....	579
05312	Steel Roof Deck .....	591
05400	Cold Formed Metal Framing .....	603
05501	Metal Fabrications .....	607
05533	Aluminum Floor Gratings and Checkered Plates .....	617



**WATERFOWL MANAGEMENT PROGRAM BUILDING AND PAVING  
CONTRACT CRO-557G, H, P, E**

**TABLE OF CONTENTS (Continued)**

---

**GENERAL SPECIFICATIONS**

<b><u>SECTION</u></b>	<b><u>DESCRIPTION</u></b>	<b><u>PAGE</u></b>
<b>DIVISION 6 WOOD AND PLASTICS</b>		
06100	Rough Carpentry .....	623
<b>DIVISION 7 THERMAL AND MOISTURE PROTECTION</b>		
07111	Bituminous Dampproofing .....	629
07210	Building Insulation.....	639
07221	Roofing Insulation .....	659
07271	Vapor and Air Barriers.....	675
07611	Sheet Metal Roofing .....	683
07620	Sheet Metal Flashing and Trim.....	707
07621	Gutters and Downspouts .....	719
07900	Caulking and Sealants.....	727
<b>DIVISION 8 DOORS AND WINDOWS</b>		
08110	Galvanized Steel Doors and Frames .....	739
08311	Access Doors .....	749
08710	Finish Hardware.....	755
08800	Glass, Plastic and Glazing.....	779
<b>DIVISION 9 FINISHES</b>		
09206	Metal Furring and Lathing.....	791
09250	Gypsum Board Systems.....	799
09310	Ceramic Tile.....	811
09511	Suspended Acoustical Ceilings.....	817
09900	Painting .....	827
<b>DIVISION 10 SPECIALTIES</b>		
10200	Louvers .....	851
10400	Identifying Devices.....	857
10500	Lockers and Benches .....	869
10521	Fire Extinguishers .....	875
10801	Toilet and Bath Accessories.....	879
<b>DIVISION 12 FURNISHINGS</b>		
12305	Storage Equipment.....	883

**WATERFOWL MANAGEMENT PROGRAM BUILDING AND PAVING  
CONTRACT CRO-557G, H, P, E**

**TABLE OF CONTENTS (Continued)**

**GENERAL SPECIFICATIONS**

<b><u>SECTION</u></b>	<b><u>DESCRIPTION</u></b>	<b><u>PAGE</u></b>
<b>DIVISION 13 SPECIAL CONSTRUCTION</b>		
13101	Lightning Protection System.....	889
13281	Asbestos Management .....	895
13282	Mercury Management.....	927
13283	Lead Management.....	947
13284	PCB Management .....	981
13851	Fire Detection and Alarm System.....	1019
 <b>DIVISION 15 MECHANICAL</b>		
15053	Aluminum, Copper and Brass Pipe.....	1049
15056	Pipe Couplings .....	1063
15060	Hangers and Supports .....	1073
15071	Vibration Control.....	1089
15076	Piping and Equipment Identification .....	1097
15081	Piping Insulation .....	1123
15112	Valves Smaller than 4 Inches.....	1139
15141	Disinfection.....	1153
15410	Plumbing Fixtures.....	1157
15760	Unit Heaters – Hot Water .....	1159
15761	Heaters, Electric.....	1165
15762	Finned Tube Radiators.....	1179
15810	Ductwork and Duct Accessories.....	1183
15815	Duct Insulation.....	1203
15830	Fans .....	1211
 <b>DIVISION 16 ELECTRICAL</b>		
16010	General Electrical Requirements .....	1229
16055	Shock Hazard and Arc Flash Studies.....	1235
16061	Grounding .....	1245
16071	Supporting Devices.....	1251
16076	Labeling and Identification .....	1257
16121	Low-Voltage Wires, Cables and Accessories.....	1263
16131	Electric Conduit System .....	1277
16133	Underground Ducts - Ducts in Concrete.....	1297
16211	Electrical Service Entrance .....	1303
16221	Electric Motors.....	1313
16271	Dry Type Transformers.....	1333
16292	Power Distribution System Coordination .....	1339

**WATERFOWL MANAGEMENT PROGRAM BUILDING AND PAVING  
CONTRACT CRO-557G, H, P, E**

**TABLE OF CONTENTS (Continued)**

---

**GENERAL SPECIFICATIONS**

<b><u>SECTION</u></b>	<b><u>DESCRIPTION</u></b>	<b><u>PAGE</u></b>
16441	Panelboards .....	1347
16442	Electric Control Equipment - Low Voltage AC Motors and Devices .....	1355
16491	Fuses .....	1363
16511	Lighting Fixtures and Devices .....	1367
16521	Outdoor Lighting .....	1383

**WATERFOWL MANAGEMENT PROGRAM BUILDING AND PAVING  
CONTRACT CRO-557G, H, P, E**

**TABLE OF CONTENTS (Continued)**

<b><u>DETAILED SPECIFICATIONS</u></b>		
<b><u>SECTION</u></b>	<b><u>DESCRIPTION</u></b>	<b><u>PAGE</u></b>
<b>DIVISION 1 GENERAL REQUIREMENTS</b>		
01120	Multiple Contract Summary .....	1389
01140	Work Restrictions .....	1395
01270	Measurement and Payment .....	1401
01291	Schedule of Values .....	1413
01310	Project Coordination and Meetings .....	1427
01312	Web-based Project Management Information System .....	1435
01321	Progress Schedule .....	1443
01323	Job Photographs and Videos .....	1473
01330	Submittal Procedures .....	1481
01332	Final Record Documents.....	1491
01333	Records in Paper Formats .....	1501
01335	Records in Electronic Formats.....	1505
01355	Hazardous Materials Control .....	1515
01356	Environmental Health and Safety (EHS) Requirements.....	1523
01410	Regulatory Requirements.....	1553
01420	Reference Standards.....	1559
01430	Approval of Product Manufacturers – Named or Equal .....	1561
01432	Contractor's Quality Control .....	1567
01433	Witness Shop Testing and Quality Assurance Inspection .....	1573
01511	Temporary Water and Sanitary Services .....	1587
01512	Temporary Heating and Ventilation Facilities.....	1589
01513	Temporary Electrical System.....	1595
01514	Interim Electrical System.....	1605
01521	Temporary Field Office Trailers.....	1615
01550	Vehicular Access and Parking .....	1631
01555	Maintenance and Protection of Traffic .....	1635
01560	Temporary Barriers and Enclosures.....	1649
01570	Temporary Controls .....	1655
01571	Temporary Pest Control.....	1661
01583	Construction Site Signs.....	1665
01615	General Electrical and Mechanical Requirements.....	1671
01651	Transportation and Handling of Materials.....	1677
01661	Protection of Materials and Equipment .....	1681
01711	Maintenance of Operations and Construction Staging .....	1685
01715	General Construction Requirements .....	1693
01721	Protection and Restoration of Structures .....	1699
01732	Installation of Equipment.....	1705
01733	Construction Waste Management .....	1713
01740	Cleaning and Site Maintenance .....	1723

**WATERFOWL MANAGEMENT PROGRAM BUILDING AND PAVING  
CONTRACT CRO-557G, H, P, E**

**TABLE OF CONTENTS (Continued)**

---

**DETAILED SPECIFICATIONS**

<b><u>SECTION</u></b>	<b><u>DESCRIPTION</u></b>	<b><u>PAGE</u></b>
01750	Spare Parts and Maintenance Materials .....	1727
01781	Project Closeout .....	1733
01811	Preliminary and Final Field Tests .....	1737
01821	Equipment Start-up and Training .....	1743
01831	Operation and Maintenance Manuals .....	1749

**WATERFOWL MANAGEMENT PROGRAM BUILDING AND PAVING  
CONTRACT CRO-557G**

**TABLE OF CONTENTS**

**DETAILED SPECIFICATIONS**

<b><u>SECTION</u></b>	<b><u>DESCRIPTION</u></b>	<b><u>PAGE</u></b>
<b>DIVISION 2</b>	<b>SITE CONSTRUCTION</b>	
02371G	Dust, Soil Erosion and Sedimentation Control .....	1755
02373	Oil Water Separator .....	1773
02374	Stormwater Treatment Device – CDS Unit .....	1779
02375	Stormwater Chamber .....	1785
02910G	Planting .....	1791
02920G	Soil Mixes .....	1819
<b>DIVISION 3</b>	<b>CONCRETE</b>	
03210G	Reinforcing Steel .....	1823
03290G	Joints in Concrete.....	1825
03300G	Cast-in-Place Concrete.....	1827
03350G	Concrete Finishes.....	1917
03600G	Grout .....	1919
<b>DIVISION 4</b>	<b>MASONRY</b>	
04400G	Stone Masonry Units.....	1921
<b>DIVISION 5</b>	<b>METALS</b>	
05092G	Metal Fastening.....	1923
05120G	Structural Steel.....	1925
05400G	Cold Formed Metal Framing .....	1939
05523	Welded Stainless Steel Railings.....	1941
<b>DIVISION 6</b>	<b>WOOD AND PLASTICS</b>	
06160	Sheathing.....	1959
06410	Plastic Laminate Clad Cabinets .....	1969
06640	PVC Paneling.....	1977
<b>DIVISION 7</b>	<b>THERMAL AND MOISTURE PROTECTION</b>	
07111G	Bituminous Dampproofing .....	1981
07271G	Vapor and Air Barriers.....	1983
07460	Fiber Cement Walls .....	1985
07611G	Sheet Metal Roofing .....	1995
07621G	Gutters and Downspouts .....	1999
07900G	Caulking and Sealants.....	2001

**WATERFOWL MANAGEMENT PROGRAM BUILDING AND PAVING  
CONTRACT CRO-557G**

**TABLE OF CONTENTS**

**DETAILED SPECIFICATIONS**

<b><u>SECTION</u></b>	<b><u>DESCRIPTION</u></b>	<b><u>PAGE</u></b>
<b>DIVISION 8 DOORS AND WINDOWS</b>		
08361	Sectional Overhead Doors .....	2003
08411	Aluminum Framed Entrances and Storefronts.....	2017
08710G	Finish Hardware.....	2029
08800G	Glass, Plastic and Glazing.....	2063
08911	Glazed Aluminum Curtain Wall System .....	2065
<b>DIVISION 9 FINISHES</b>		
09250G	Gypsum Board Systems.....	2077
09651	Resilient Flooring.....	2079
09672	Resinous Flooring.....	2091
<b>DIVISION 12 FURNISHINGS</b>		
12481	Entrance Floor Mats and Frames .....	2101
<b>DIVISION 13 SPECIAL CONSTRUCTION</b>		
13281G	Asbestos Management .....	2107
13282G	Mercury Management.....	2109
13284G	PCB Management .....	2111
13321	Spill Response Storage Containers .....	2113
<b>DIVISION 16 ELECTRICAL</b>		
16121G	Low-Voltage Wires, Cables and Accessories.....	2119
16126	Fiber Optic Cable and Accessories .....	2121
16131G	Electrical Conduit System.....	2145
16852	Closed Circuit Television .....	2147

**WATERFOWL MANAGEMENT PROGRAM BUILDING AND PAVING  
CONTRACT CRO-557G**

**TABLE OF CONTENTS**

---

**DETAILED SPECIFICATIONS**

<b><u>SECTION</u></b>	<b><u>DESCRIPTION</u></b>	<b><u>PAGE</u></b>
<b>DIVISION 17 INSTRUMENTATION AND CONTROLS</b>		
17403	Network Security and CCTV Site Monitoring and Control System Start-up and Field Testing .....	2159
17420	Network Security and CCTV Control Panels and Enclosures.....	2163
17430	Network Security and CCTV Mounted Instruments and Devices.....	2179
17440	Network Security and CCTV Access Control and Intrusion Alarm System .....	2197
17790	Communications Networks and Equipment .....	2217



**WATERFOWL MANAGEMENT PROGRAM BUILDING AND PAVING  
CONTRACT CRO-557H**

**TABLE OF CONTENTS**

**DETAILED SPECIFICATIONS**

<b><u>SECTION</u></b>	<b><u>DESCRIPTION</u></b>	<b><u>PAGE</u></b>
<b>DIVISION 15 MECHANICAL</b>		
15053H	Aluminum, Brass and Copper Pipe.....	2243
15060H	Hangers and Supports .....	2245
15081H	Piping Insulation .....	2247
15112H	Valves Smaller than 4 Inches.....	2249
15130	Piping Specialties.....	2251
15500	Basic HVAC Requirements .....	2261
15513	Hot Water Boilers .....	2269
15530	HVAC Pumps .....	2277
15608	HVAC Electric Control Systems .....	2289
15730	Split System Air Conditioners .....	2303
15735	Dehumidifiers .....	2315
15760H	Unit Heaters – Hot Water .....	2323
15761H	Heaters, Electric.....	2325
15762H	Finned Tube Radiation.....	2327
15810H	Ductwork and Duct Accessories.....	2329
15815H	Duct Insulation.....	2333
15830H	Fans .....	2335
15951	Testing, Adjusting and Balancing.....	2337

**WATERFOWL MANAGEMENT PROGRAM BUILDING AND PAVING  
CONTRACT CRO-557P**

**TABLE OF CONTENTS**

---

**DETAILED SPECIFICATIONS**

<b><u>SECTION</u></b>	<b><u>DESCRIPTION</u></b>	<b><u>PAGE</u></b>
<b>DIVISION 15 MECHANICAL</b>		
15009	High Density Polyethylene (HDPE) Pipe .....	2355
	Con Edison Yellow Book .....	2361
15056P	Pipe Couplings .....	2499
15060P	Hangers and Supports .....	2501
15081P	Piping Insulation .....	2503
15112P	Valves Smaller than 4 Inches.....	2505
15141P	Disinfection.....	2507
15400	Plumbing.....	2509
15410P	Plumbing Fixtures.....	2535

**WATERFOWL MANAGEMENT PROGRAM BUILDING AND PAVING  
CONTRACT CRO-557E**

**TABLE OF CONTENTS**

**DETAILED SPECIFICATIONS**

<b><u>SECTION</u></b>	<b><u>DESCRIPTION</u></b>	<b><u>PAGE</u></b>
<b>DIVISION 13 SPECIAL CONSTRUCTION</b>		
13101E	Lightning Protection System.....	2559
13321	Spill Response Storage Containers .....	2561
<b>DIVISION 16 ELECTRICAL</b>		
16010E	General Electrical Requirements .....	2567
16061E	Grounding .....	2569
16071E	Supporting Devices.....	2571
16076E	Labeling and Identification .....	2573
16121E	Low-Voltage Wires, Cables and Accessories .....	2575
16131E	Electric Conduit System .....	2577
16211E	Electrical Service Entrance .....	2579
16221E	Electric Motors.....	2581
16231E	Standby Power .....	2583
16243	Electric-Vehicle Charging Station .....	2603
16271E	Dry Type Transformers.....	2609
16413	Enclosed Transfer Switches.....	2611
16441E	Panelboards .....	2617
16511E	Lighting Fixtures and Devices .....	2619
16521E	Outdoor Lighting .....	2643



**WATERFOWL MANAGEMENT PROGRAM BUILDING AND PAVING  
CONTRACT CRO-557**

**TABLE OF CONTENTS**

---

NO TEXT ON THIS PAGE

## WESTCHESTER COUNTY

# SCHEDULE OF PREVAILING WAGES

**Note:** The Contractor and its subcontractors shall pay the applicable and lawful prevailing wages and supplements to workers at the time work is performed. Changes in wage rates and supplements resulting from changes to the applicable and lawful prevailing wage schedules shall not be the basis for a change in the contract price.

NO TEXT FOR THIS PAGE

Note: The following is a listing of those trades expected to be utilized on this project. If a Contractor proposes to use an alternative trade, he must notify the DEP Contract Compliance Office at 718-595-3211.

:     **Contract(s):**     CRO-557G, CRO-557H, CRO-557P, CRO-557E  
  
      **Description:**     Waterfowl Management Program Building and Paving

**SCHEDULE OF WORKMEN, MECHANICS AND LABORERS**  
**(Listed by Individual Contract)**

CRO-557G

- Carpenter (Bldg., H&H, Pile Driver/Dockbuilder)
- Carpenter (Residential)
- Electrical (Inside)
- Glazier
- Insulation & Asbestos Worker
- Iron Worker
- Laborer
- Mason
- Operating Engineer
- Painter
- Roofer
- Teamster – Heavy and Highway
- Welder

CRO-557H

- Plumber and Steamfitter
- Laborer
- Teamster – Building

CRO-557P

- Plumber and Steamfitter
- Laborer
- Teamster – Building

CRO-557E

- Electrical (Outside) Lineman
- Electrical (Inside)
- Laborer

NO TEXT FOR THIS PAGE





Kathy Hochul, Governor

Roberta Reardon, Commissioner

New York City DEP  
Ryan Neumann, Engineer  
498 Seventh Avenue  
11th Floor  
New York NY 10018

Schedule Year 2021 through 2022  
Date Requested 12/23/2020  
PRC# 2020012686

Location Mount Pleasant  
Project ID# CRO-557  
Project Type Waterfowl Management Program Building and Paving

### PREVAILING WAGE SCHEDULE FOR ARTICLE 8 PUBLIC WORK PROJECT

Attached is the current schedule(s) of the prevailing wage rates and prevailing hourly supplements for the project referenced above. A unique Prevailing Wage Case Number (PRC#) has been assigned to the schedule(s) for your project.

The schedule is effective from July 2021 through June 2022. All updates, corrections, posted on the 1st business day of each month, and future copies of the annual determination are available on the Department's website [www.labor.ny.gov](http://www.labor.ny.gov). Updated PDF copies of your schedule can be accessed by entering your assigned PRC# at the proper location on the website.

It is the responsibility of the contracting agency or its agent to annex and make part, the attached schedule, to the specifications for this project, when it is advertised for bids and /or to forward said schedules to the successful bidder(s), immediately upon receipt, in order to insure the proper payment of wages.

Please refer to the "General Provisions of Laws Covering Workers on Public Work Contracts" provided with this schedule, for the specific details relating to other responsibilities of the Department of Jurisdiction.

Upon completion or cancellation of this project, enter the required information and mail **OR** fax this form to the office shown at the bottom of this notice, **OR** fill out the electronic version via the NYSDOL website.

#### NOTICE OF COMPLETION / CANCELLATION OF PROJECT

Date Completed: \_\_\_\_\_ Date Cancelled: \_\_\_\_\_

Name & Title of Representative: \_\_\_\_\_

Phone: (518) 457-5589 Fax: (518) 485-1870  
W. Averell Harriman State Office Campus, Bldg. 12, Room 130, Albany, NY 12240



# General Provisions of Laws Covering Workers on Article 8 Public Work Contracts

## Introduction

The Labor Law requires public work contractors and subcontractors to pay laborers, workers, or mechanics employed in the performance of a public work contract not less than the prevailing rate of wage and supplements (fringe benefits) in the locality where the work is performed.

## Responsibilities of the Department of Jurisdiction

A Department of Jurisdiction (Contracting Agency) includes a state department, agency, board or commission; a county, city, town or village; a school district, board of education or board of cooperative educational services; a sewer, water, fire, improvement and other district corporation; a public benefit corporation; and a public authority awarding a public work contract.

The Department of Jurisdiction (Contracting Agency) awarding a public work contract MUST obtain a Prevailing Rate Schedule listing the hourly rates of wages and supplements due the workers to be employed on a public work project. This schedule may be obtained by completing and forwarding a "Request for wage and Supplement Information" form (PW 39) to the Bureau of Public Work. The Prevailing Rate Schedule MUST be included in the specifications for the contract to be awarded and is deemed part of the public work contract.

Upon the awarding of the contract, the law requires that the Department of Jurisdiction (Contracting Agency) furnish the following information to the Bureau: the name and address of the contractor, the date the contract was let and the approximate dollar value of the contract. To facilitate compliance with this provision of the Labor Law, a copy of the Department's "Notice of Contract Award" form (PW 16) is provided with the original Prevailing Rate Schedule.

The Department of Jurisdiction (Contracting Agency) is required to notify the Bureau of the completion or cancellation of any public work project. The Department's PW 200 form is provided for that purpose.

Both the PW 16 and PW 200 forms are available for completion [online](#).

## Hours

No laborer, worker, or mechanic in the employ of a contractor or subcontractor engaged in the performance of any public work project shall be permitted to work more than eight hours in any day or more than five days in any week, except in cases of extraordinary emergency. The contractor and the Department of Jurisdiction (Contracting Agency) may apply to the Bureau of Public Work for a dispensation permitting workers to work additional hours or days per week on a particular public work project.

There are very few exceptions to this rule. Complete information regarding these exceptions is available on the ["Request for a dispensation to work overtime" form \(PW30\)](#) and ["4 Day / 10 Hour Work Schedule" form \(PW 30.1\)](#).

## Wages and Supplements

The wages and supplements to be paid and/or provided to laborers, workers, and mechanics employed on a public work project shall be not less than those listed in the current Prevailing Rate Schedule for the locality where the work is performed. If a prime contractor on a public work project has not been provided with a Prevailing Rate Schedule, the contractor must notify the Department of Jurisdiction (Contracting Agency) who in turn must request an original Prevailing Rate Schedule form the Bureau of Public Work. Requests may be submitted by: mail to NYSDOL, Bureau of Public Work, State Office Bldg. Campus, Bldg. 12, Rm. 130, Albany, NY 12240; Fax to Bureau of Public Work (518) 485-1870; or electronically at the NYSDOL website [www.labor.ny.gov](http://www.labor.ny.gov).

Upon receiving the original schedule, the Department of Jurisdiction (Contracting Agency) is REQUIRED to provide complete copies to all prime contractors who in turn MUST, by law, provide copies of all applicable county schedules to each subcontractor and obtain from each subcontractor, an affidavit certifying such schedules were received. If the original schedule expired, the contractor may obtain a copy of the new annual determination from the NYSDOL website [www.labor.ny.gov](http://www.labor.ny.gov).

The Commissioner of Labor makes an annual determination of the prevailing rates. This determination is in effect from July 1st through June 30th of the following year. The annual determination is available on the NYSDOL website [www.labor.ny.gov](http://www.labor.ny.gov).

## Payrolls and Payroll Records

Every contractor and subcontractor MUST keep original payrolls or transcripts subscribed and affirmed as true under penalty of perjury. As per Article 6 of the Labor law, contractors and subcontractors are required to establish, maintain, and preserve for not less than six (6) years, contemporaneous, true, and accurate payroll records. At a minimum, payrolls must show the following information for each person employed on a public work project: Name, Address, Last 4 Digits of Social Security Number, Classification(s) in which the worker was employed, Hourly wage rate(s) paid, Supplements paid

or provided, and Daily and weekly number of hours worked in each classification.

The filing of payrolls to the Department of Jurisdiction is a condition of payment. Every contractor and subcontractor shall submit to the Department of Jurisdiction (Contracting Agency), within thirty (30) days after issuance of its first payroll and every thirty (30) days thereafter, a transcript of the original payrolls, subscribed and affirmed as true under penalty of perjury. The Department of Jurisdiction (Contracting Agency) shall collect, review for facial validity, and maintain such payrolls.

In addition, the Commissioner of Labor may require contractors to furnish, with ten (10) days of a request, payroll records sworn to as their validity and accuracy for public work and private work. Payroll records include, but are not limited to time cards, work description sheets, proof that supplements were provided, cancelled payroll checks and payrolls. Failure to provide the requested information within the allotted ten (10) days will result in the withholding of up to 25% of the contract, not to exceed \$100,000.00. If the contractor or subcontractor does not maintain a place of business in New York State and the amount of the contract exceeds \$25,000.00, payroll records and certifications must be kept on the project worksite.

The prime contractor is responsible for any underpayments of prevailing wages or supplements by any subcontractor.

All contractors or their subcontractors shall provide to their subcontractors a copy of the Prevailing Rate Schedule specified in the public work contract as well as any subsequently issued schedules. A failure to provide these schedules by a contractor or subcontractor is a violation of Article 8, Section 220-a of the Labor Law.

All subcontractors engaged by a public work project contractor or its subcontractor, upon receipt of the original schedule and any subsequently issued schedules, shall provide to such contractor a verified statement attesting that the subcontractor has received the Prevailing Rate Schedule and will pay or provide the applicable rates of wages and supplements specified therein. (See NYS Labor Laws, Article 8 . Section 220-a).

### **Determination of Prevailing Wage and Supplement Rate Updates Applicable to All Counties**

The wages and supplements contained in the annual determination become effective July 1st whether or not the new determination has been received by a given contractor. Care should be taken to review the rates for obvious errors. Any corrections should be brought to the Department's attention immediately. It is the responsibility of the public work contractor to use the proper rates. If there is a question on the proper classification to be used, please call the district office located nearest the project. Any errors in the annual determination will be corrected and posted to the NYSDOL website on the first business day of each month. Contractors are responsible for paying these updated rates as well, retroactive to July 1st.

When you review the schedule for a particular occupation, your attention should be directed to the dates above the column of rates. These are the dates for which a given set of rates is effective. To the extent possible, the Department posts rates in its possession that cover periods of time beyond the July 1st to June 30th time frame covered by a particular annual determination. Rates that extend beyond that instant time period are informational ONLY and may be updated in future annual determinations that actually cover the then appropriate July 1st to June 30th time period.

### **Withholding of Payments**

When a complaint is filed with the Commissioner of Labor alleging the failure of a contractor or subcontractor to pay or provide the prevailing wages or supplements, or when the Commissioner of Labor believes that unpaid wages or supplements may be due, payments on the public work contract shall be withheld from the prime contractor in a sufficient amount to satisfy the alleged unpaid wages and supplements, including interest and civil penalty, pending a final determination.

When the Bureau of Public Work finds that a contractor or subcontractor on a public work project failed to pay or provide the requisite prevailing wages or supplements, the Bureau is authorized by Sections 220-b and 235.2 of the Labor Law to so notify the financial officer of the Department of Jurisdiction (Contracting Agency) that awarded the public work contract. Such officer MUST then withhold or cause to be withheld from any payment due the prime contractor on account of such contract the amount indicated by the Bureau as sufficient to satisfy the unpaid wages and supplements, including interest and any civil penalty that may be assessed by the Commissioner of Labor. The withholding continues until there is a final determination of the underpayment by the Commissioner of Labor or by the court in the event a legal proceeding is instituted for review of the determination of the Commissioner of Labor.

The Department of Jurisdiction (Contracting Agency) shall comply with this order of the Commissioner of Labor or of the court with respect to the release of the funds so withheld.

### **Summary of Notice Posting Requirements**

The current Prevailing Rate Schedule must be posted in a prominent and accessible place on the site of the public work project. The prevailing wage schedule must be encased in, or constructed of, materials capable of withstanding adverse weather conditions and be titled "PREVAILING RATE OF WAGES" in letters no smaller than two (2) inches by two (2) inches.

The "Public Work Project" notice must be posted at the beginning of the performance of every public work contract, on each job site.

Every employer providing workers' compensation insurance and disability benefits must post notices of such coverage in the format prescribed by the Workers' Compensation Board in a conspicuous place on the jobsite.

Every employer subject to the NYS Human Rights Law must conspicuously post at its offices, places of employment, or employment training centers, notices furnished by the State Division of Human Rights.

Employers liable for contributions under the Unemployment Insurance Law must conspicuously post on the jobsite notices furnished by the NYS Department of Labor.

## **Apprentices**

Employees cannot be paid apprentice rates unless they are individually registered in a program registered with the NYS Commissioner of Labor. The allowable ratio of apprentices to journeyworkers in any craft classification can be no greater than the statewide building trade ratios promulgated by the Department of Labor and included with the Prevailing Rate Schedule. An employee listed on a payroll as an apprentice who is not registered as above or is performing work outside the classification of work for which the apprentice is indentured, must be paid the prevailing journeyworker's wage rate for the classification of work the employee is actually performing.

NYSDOL Labor Law, Article 8, Section 220-3, require that only apprentices individually registered with the NYS Department of Labor may be paid apprenticeship rates on a public work project. No other Federal or State Agency of office registers apprentices in New York State.

Persons wishing to verify the apprentice registration of any person must do so in writing by mail, to the NYSDOL Office of Employability Development / Apprenticeship Training, State Office Bldg. Campus, Bldg. 12, Albany, NY 12240 or by Fax to NYSDOL Apprenticeship Training (518) 457-7154. All requests for verification must include the name and social security number of the person for whom the information is requested.

The only conclusive proof of individual apprentice registration is written verification from the NYSDOL Apprenticeship Training Albany Central office. Neither Federal nor State Apprenticeship Training offices outside of Albany can provide conclusive registration information.

It should be noted that the existence of a registered apprenticeship program is not conclusive proof that any person is registered in that program. Furthermore, the existence or possession of wallet cards, identification cards, or copies of state forms is not conclusive proof of the registration of any person as an apprentice.

## **Interest and Penalties**

In the event that an underpayment of wages and/or supplements is found:

- Interest shall be assessed at the rate then in effect as prescribed by the Superintendent of Banks pursuant to section 14-a of the Banking Law, per annum from the date of underpayment to the date restitution is made.
- A Civil Penalty may also be assessed, not to exceed 25% of the total of wages, supplements, and interest due.

## **Debarment**

Any contractor or subcontractor and/or its successor shall be ineligible to submit a bid on or be awarded any public work contract or subcontract with any state, municipal corporation or public body for a period of five (5) years when:

- Two (2) willful determinations have been rendered against that contractor or subcontractor and/or its successor within any consecutive six (6) year period.
- There is any willful determination that involves the falsification of payroll records or the kickback of wages or supplements.

## **Criminal Sanctions**

Willful violations of the Prevailing Wage Law (Article 8 of the Labor Law) may be a felony punishable by fine or imprisonment of up to 15 years, or both.

## **Discrimination**

No employee or applicant for employment may be discriminated against on account of age, race, creed, color, national origin, sex, disability or marital status.

No contractor, subcontractor nor any person acting on its behalf, shall by reason of race, creed, color, disability, sex or national origin discriminate against any citizen of the State of New York who is qualified and available to perform the work to which the employment relates (NYS Labor Law, Article 8, Section 220-e(a)).

No contractor, subcontractor, nor any person acting on its behalf, shall in any manner, discriminate against or intimidate any employee on account of race, creed, color, disability, sex, or national origin (NYS Labor Law, Article 8, Section 220-e(b) ).

The Human Rights Law also prohibits discrimination in employment because of age, marital status, or religion.

There may be deducted from the amount payable to the contractor under the contract a penalty of \$50.00 for each calendar day during which such person was discriminated against or intimidated in violation of the provision of the contract (NYS Labor Law, Article 8, Section 220-e(c) ).

The contract may be cancelled or terminated by the State or municipality. All monies due or to become due thereunder may be forfeited for a second or any subsequent violation of the terms or conditions of the anti-discrimination sections of the contract (NYS Labor Law, Article 8, Section 220-e(d) ).

Every employer subject to the New York State Human Rights Law must conspicuously post at its offices, places of employment, or employment training centers notices furnished by the State Division of Human Rights.

### **Workers' Compensation**

In accordance with Section 142 of the State Finance Law, the contractor shall maintain coverage during the life of the contract for the benefit of such employees as required by the provisions of the New York State Workers' Compensation Law.

A contractor who is awarded a public work contract must provide proof of workers' compensation coverage prior to being allowed to begin work.

The insurance policy must be issued by a company authorized to provide workers' compensation coverage in New York State. Proof of coverage must be on form C-105.2 (Certificate of Workers' Compensation Insurance) and must name this agency as a certificate holder.

If New York State coverage is added to an existing out-of-state policy, it can only be added to a policy from a company authorized to write workers' compensation coverage in this state. The coverage must be listed under item 3A of the information page.

The contractor must maintain proof that subcontractors doing work covered under this contract secured and maintained a workers' compensation policy for all employees working in New York State.

Every employer providing worker's compensation insurance and disability benefits must post notices of such coverage in the format prescribed by the Workers' Compensation Board in a conspicuous place on the jobsite.

### **Unemployment Insurance**

Employers liable for contributions under the Unemployment Insurance Law must conspicuously post on the jobsite notices furnished by the New York State Department of Labor.



Kathy Hochul, Governor

Roberta Reardon, Commissioner

New York City DEP  
Ryan Neumann, Engineer  
498 Seventh Avenue  
11th Floor  
New York NY 10018

Schedule Year 2021 through 2022  
Date Requested 12/23/2020  
PRC# 2020012686

Location Mount Pleasant  
Project ID# CRO-557  
Project Type Waterfowl Management Program Building and Paving

### Notice of Contract Award

New York State Labor Law, Article 8, Section 220.3a requires that certain information regarding the awarding of public work contracts, be furnished to the Commissioner of Labor. One "Notice of Contract Award" (PW 16, which may be photocopied), **MUST** be completed for **EACH** prime contractor on the above referenced project.

Upon notifying the successful bidder(s) of this contract, enter the required information and mail **OR** fax this form to the office shown at the bottom of this notice, **OR** fill out the electronic version via the NYSDOL website.

### Contractor Information

All information must be supplied

Federal Employer Identification Number: _____		
Name: _____		
Address: _____ _____		
City: _____	State: _____	Zip: _____
Amount of Contract: \$ _____	Contract Type:	
Approximate Starting Date: ____/____/____	<input type="checkbox"/> (01) General Construction	
Approximate Completion Date: ____/____/____	<input type="checkbox"/> (02) Heating/Ventilation	
	<input type="checkbox"/> (03) Electrical	
	<input type="checkbox"/> (04) Plumbing	
	<input type="checkbox"/> (05) Other : _____	

Phone: (518) 457-5589 Fax: (518) 485-1870  
W. Averell Harriman State Office Campus, Bldg. 12, Room 130, Albany, NY 12240





## **Social Security Numbers on Certified Payrolls:**

The Department of Labor is cognizant of the concerns of the potential for misuse or inadvertent disclosure of social security numbers. Identity theft is a growing problem and we are sympathetic to contractors' concern regarding inclusion of this information on payrolls if another identifier will suffice.

For these reasons, the substitution of the use of the last four digits of the social security number on certified payrolls submitted to contracting agencies on public work projects is now acceptable to the Department of Labor. This change does not affect the Department's ability to request and receive the entire social security number from employers during its public work/ prevailing wage investigations.

## **Construction Industry Fair Play Act: Required Posting for Labor Law Article 25-B § 861-d**

Construction industry employers must post the "Construction Industry Fair Play Act" notice in a prominent and accessible place on the job site. Failure to post the notice can result in penalties of up to \$1,500 for a first offense and up to \$5,000 for a second offense. The posting is included as part of this wage schedule. Additional copies may be obtained from the NYS DOL website, [www.labor.ny.gov](http://www.labor.ny.gov). <https://labor.ny.gov/formsdocs/ui/1A999.pdf>

If you have any questions concerning the Fair Play Act, please call the State Labor Department toll-free at 1-866-435-1499 or email us at: [dol.misclassified@labor.ny.gov](mailto:dol.misclassified@labor.ny.gov) .

## **Worker Notification: (Labor Law §220, paragraph a of subdivision 3-a)**

### **Effective June 23, 2020**

This provision is an addition to the existing wage rate law, Labor Law §220, paragraph a of subdivision 3-a. It requires contractors and subcontractors to provide written notice to all laborers, workers or mechanics of the *prevailing wage and supplement rate* for their particular job classification *on each pay stub*\*. It also requires contractors and subcontractors to *post a notice* at the beginning of the performance of every public work contract *on each job site* that includes the telephone number and address for the Department of Labor and a statement informing laborers, workers or mechanics of their right to contact the Department of Labor if he/she is not receiving the proper prevailing rate of wages and/or supplements for his/her job classification. The required notification will be provided with each wage schedule, may be downloaded from our website [www.labor.ny.gov](http://www.labor.ny.gov) or be made available upon request by contacting the Bureau of Public Work at 518-457-5589. \*In the event the required information will not fit on the pay stub, an accompanying sheet or attachment of the information will suffice.

(12.20)

**To all State Departments, Agency Heads and Public Benefit Corporations  
IMPORTANT NOTICE REGARDING PUBLIC WORK ENFORCEMENT FUND**

## **Budget Policy & Reporting Manual**

# **B-610**

## **Public Work Enforcement Fund**

*effective date December 7, 2005*

---

### **1. Purpose and Scope:**

This Item describes the Public Work Enforcement Fund (the Fund, PWEF) and its relevance to State agencies and public benefit corporations engaged in construction or reconstruction contracts, maintenance and repair, and announces the recently-enacted increase to the percentage of the dollar value of such contracts that must be deposited into the Fund. This item also describes the roles of the following entities with respect to the Fund:

- New York State Department of Labor (DOL),
- The Office of the State of Comptroller (OSC), and
- State agencies and public benefit corporations.

### **2. Background and Statutory References:**

DOL uses the Fund to enforce the State's Labor Law as it relates to contracts for construction or reconstruction, maintenance and repair, as defined in subdivision two of Section 220 of the Labor Law. State agencies and public benefit corporations participating in such contracts are required to make payments to the Fund.

Chapter 511 of the Laws of 1995 (as amended by Chapter 513 of the Laws of 1997, Chapter 655 of the Laws of 1999, Chapter 376 of the Laws of 2003 and Chapter 407 of the Laws of 2005) established the Fund.

### **3. Procedures and Agency Responsibilities:**

The Fund is supported by transfers and deposits based on the value of contracts for construction and reconstruction, maintenance and repair, as defined in subdivision two of Section 220 of the Labor Law, into which all State agencies and public benefit corporations enter.

Chapter 407 of the Laws of 2005 increased the amount required to be provided to this fund to .10 of one-percent of the total cost of each such contract, to be calculated at the time agencies or public benefit corporations enter into a new contract or if a contract is amended. The provisions of this bill became effective August 2, 2005.

**To all State Departments, Agency Heads and Public Benefit Corporations  
IMPORTANT NOTICE REGARDING PUBLIC WORK ENFORCEMENT FUND**

OSC will report to DOL on all construction-related ("D") contracts approved during the month, including contract amendments, and then DOL will bill agencies the appropriate assessment monthly. An agency may then make a determination if any of the billed contracts are exempt and so note on the bill submitted back to DOL. For any instance where an agency is unsure if a contract is or is not exempt, they can call the Bureau of Public Work at the number noted below for a determination. Payment by check or journal voucher is due to DOL within thirty days from the date of the billing. DOL will verify the amounts and forward them to OSC for processing.

For those contracts which are not approved or administered by the Comptroller, monthly reports and payments for deposit into the Public Work Enforcement Fund must be provided to the Administrative Finance Bureau at the DOL within 30 days of the end of each month or on a payment schedule mutually agreed upon with DOL.

Reports should contain the following information:

- Name and billing address of State agency or public benefit corporation;
- State agency or public benefit corporation contact and phone number;
- Name and address of contractor receiving the award;
- Contract number and effective dates;
- Contract amount and PWEF assessment charge (if contract amount has been amended, reflect increase or decrease to original contract and the adjustment in the PWEF charge); and
- Brief description of the work to be performed under each contract.

Checks and Journal Vouchers, payable to the "New York State Department of Labor" should be sent to:

Department of Labor  
Administrative Finance Bureau-PWEF Unit  
Building 12, Room 464  
State Office Campus  
Albany, NY 12240

Any questions regarding billing should be directed to NYSDOL's Administrative Finance Bureau-PWEF Unit at (518) 457-3624 and any questions regarding Public Work Contracts should be directed to the Bureau of Public Work at (518) 457-5589.



Required Notice under Article 25-B of the Labor Law

**Attention All Employees, Contractors and Subcontractors:  
You are Covered by the Construction Industry Fair Play Act**

**The law says that you are an employee unless:**

- You are free from direction and control in performing your job, **and**
- You perform work that is not part of the usual work done by the business that hired you, **and**
- You have an independently established business.

Your employer cannot consider you to be an independent contractor unless all three of these facts apply to your work.

**It is against the law for an employer to misclassify employees as independent contractors or pay employees off the books.**

**Employee Rights:** If you are an employee, you are entitled to state and federal worker protections. These include:

- Unemployment Insurance benefits, if you are unemployed through no fault of your own, able to work, and otherwise qualified,
- Workers' compensation benefits for on-the-job injuries,
- Payment for wages earned, minimum wage, and overtime (under certain conditions),
- Prevailing wages on public work projects,
- The provisions of the National Labor Relations Act, and
- A safe work environment.

It is a violation of this law for employers to retaliate against anyone who asserts their rights under the law. Retaliation subjects an employer to civil penalties, a private lawsuit or both.

**Independent Contractors:** If you are an independent contractor, **you must pay all taxes and Unemployment Insurance contributions required by New York State and Federal Law.**

**Penalties** for paying workers off the books or improperly treating employees as independent contractors:

- **Civil Penalty**                      First offense: Up to \$2,500 per employee  
    Subsequent offense(s): Up to \$5,000 per employee
- **Criminal Penalty**                First offense: Misdemeanor - up to 30 days in jail, up to a \$25,000 fine and debarment from performing public work for up to one year.  
    Subsequent offense(s): Misdemeanor - up to 60 days in jail or up to a \$50,000 fine and debarment from performing public work for up to 5 years.

**If you have questions about your employment status or believe that your employer may have violated your rights and you want to file a complaint, call the Department of Labor at (866) 435-1499 or send an email to [dol.misclassified@labor.ny.gov](mailto:dol.misclassified@labor.ny.gov). All complaints of fraud and violations are taken seriously. You can remain anonymous.**

**Employer Name:**

IA 999 (09/16)



# Attention Employees

## THIS IS A: **PUBLIC WORK PROJECT**

If you are employed on this project as a **worker, laborer, or mechanic** you are entitled to receive the **prevailing wage and supplements rate** for the classification at which you are working.

Chapter 629 of the Labor Laws of 2007:

**These wages are set by law and must be posted at the work site. They can also be found at:**  
[www.labor.ny.gov](http://www.labor.ny.gov)

If you feel that you have not received proper wages or benefits, please call our nearest office.\*

Albany	(518) 457-2744	Patchogue	(631) 687-4882
Binghamton	(607) 721-8005	Rochester	(585) 258-4505
Buffalo	(716) 847-7159	Syracuse	(315) 428-4056
Garden City	(516) 228-3915	Utica	(315) 793-2314
New York City	(212) 932-2419	White Plains	(914) 997-9507
Newburgh	(845) 568-5156		

\* For New York City government agency construction projects, please contact the Office of the NYC Comptroller at (212) 669-4443, or [www.comptroller.nyc.gov](http://www.comptroller.nyc.gov) – click on Bureau of Labor Law.

Contractor Name: \_\_\_\_\_

Project Location: \_\_\_\_\_





## Requirements for OSHA 10 Compliance

Article 8 §220-h requires that when the advertised specifications, for every contract for public work, is \$250,000.00 or more the contract must contain a provision requiring that every worker employed in the performance of a public work contract shall be certified as having completed an OSHA 10 safety training course. The clear intent of this provision is to require that all employees of public work contractors, required to be paid prevailing rates, receive such training "prior to the performing any work on the project."

### The Bureau will enforce the statute as follows:

All contractors and sub contractors must attach a copy of proof of completion of the OSHA 10 course to the first certified payroll submitted to the contracting agency and on each succeeding payroll where any new or additional employee is first listed.

Proof of completion may include but is not limited to:

- Copies of bona fide course completion card (*Note: Completion cards do not have an expiration date.*)
- Training roster, attendance record or other documentation from the certified trainer pending the issuance of the card.
- Other valid proof

\*\*A certification by the employer attesting that all employees have completed such a course is not sufficient proof that the course has been completed.

Any questions regarding this statute may be directed to the New York State Department of Labor, Bureau of Public Work at 518-457-5589.

## WICKS

Public work projects are subject to the Wicks Law requiring separate specifications and bidding for the plumbing, heating and electrical work, when the total project's threshold is \$3 million in Bronx, Kings, New York, Queens and, Richmond counties; \$1.5 million in Nassau, Suffolk and Westchester counties; and \$500,000 in all other counties.

For projects below the monetary threshold, bidders must submit a sealed list naming each subcontractor for the plumbing, HVAC and electrical and the amount to be paid to each. The list may not be changed unless the public owner finds a legitimate construction need, including a change in specifications or costs or the use of a Project Labor Agreement (PLA), and must be open to public inspection.

Allows the state and local agencies and authorities to waive the Wicks Law and use a PLA if it will provide the best work at the lowest possible price. If a PLA is used, all contractors shall participate in apprentice training programs in the trades of work it employs that have been approved by the Department of Labor (DOL) for not less than three years. They shall also have at least one graduate in the last three years and use affirmative efforts to retain minority apprentices. PLA's would be exempt from Wicks, but deemed to be public work subject to prevailing wage enforcement.

The Commissioner of Labor shall have the power to enforce separate specification requirements on projects, and may issue stop-bid orders against public owners for non-compliance.

Other new monetary thresholds, and similar sealed bidding for non-Wicks projects, would apply to certain public authorities including municipal housing authorities, NYC Construction Fund, Yonkers Educational Construction Fund, NYC Municipal Water Finance Authority, Buffalo Municipal Water Finance Authority, Westchester County Health Care Association, Nassau County Health Care Corp., Clifton-Fine Health Care Corp., Erie County Medical Center Corp., NYC Solid Waste Management Facilities, and the Dormitory Authority.

Contractors must pay subcontractors within a 7 days period.

(07.19)

## Introduction to the Prevailing Rate Schedule

### Information About Prevailing Rate Schedule

This information is provided to assist you in the interpretation of particular requirements for each classification of worker contained in the attached Schedule of Prevailing Rates.

#### Classification

It is the duty of the Commissioner of Labor to make the proper classification of workers taking into account whether the work is heavy and highway, building, sewer and water, tunnel work, or residential, and to make a determination of wages and supplements to be paid or provided. It is the responsibility of the public work contractor to use the proper rate. If there is a question on the proper classification to be used, please call the district office located nearest the project. District office locations and phone numbers are listed below.

Prevailing Wage Schedules are issued separately for "General Construction Projects" and "Residential Construction Projects" on a county-by-county basis.

General Construction Rates apply to projects such as: Buildings, Heavy & Highway, and Tunnel and Water & Sewer rates.

Residential Construction Rates generally apply to construction, reconstruction, repair, alteration, or demolition of one family, two family, row housing, or rental type units intended for residential use.

Some rates listed in the Residential Construction Rate Schedule have a very limited applicability listed along with the rate. Rates for occupations or locations not shown on the residential schedule must be obtained from the General Construction Rate Schedule. Please contact the local Bureau of Public Work office before using Residential Rate Schedules, to ensure that the project meets the required criteria.

#### Payrolls and Payroll Records

Contractors and subcontractors are required to establish, maintain, and preserve for not less than six (6) years, contemporaneous, true, and accurate payroll records.

Every contractor and subcontractor shall submit to the Department of Jurisdiction (Contracting Agency), within thirty (30) days after issuance of its first payroll and every thirty (30) days thereafter, a transcript of the original payrolls, subscribed and affirmed as true under penalty of perjury.

#### Paid Holidays

Paid Holidays are days for which an eligible employee receives a regular day's pay, but is not required to perform work. If an employee works on a day listed as a paid holiday, this remuneration is in addition to payment of the required prevailing rate for the work actually performed.

#### Overtime

At a minimum, all work performed on a public work project in excess of eight hours in any one day or more than five days in any workweek is overtime. However, the specific overtime requirements for each trade or occupation on a public work project may differ. Specific overtime requirements for each trade or occupation are contained in the prevailing rate schedules.

Overtime holiday pay is the premium pay that is required for work performed on specified holidays. It is only required where the employee actually performs work on such holidays.

The applicable holidays are listed under HOLIDAYS: OVERTIME. The required rate of pay for these covered holidays can be found in the OVERTIME PAY section listings for each classification.

#### Supplemental Benefits

Particular attention should be given to the supplemental benefit requirements. Although in most cases the payment or provision of supplements is straight time for all hours worked, some classifications require the payment or provision of supplements, or a portion of the supplements, to be paid or provided at a premium rate for premium hours worked. Supplements may also be required to be paid or provided on paid holidays, regardless of whether the day is worked. The Overtime Codes and Notes listed on the particular wage classification will indicate these conditions as required.

#### Effective Dates

When you review the schedule for a particular occupation, your attention should be directed to the dates above the column of rates. These are the dates for which a given set of rates is effective. The rate listed is valid until the next effective rate change or until the new annual determination which takes effect on July 1 of each year. All contractors and subcontractors are required to pay the current prevailing rates of wages and supplements. If you have any questions please contact the Bureau of Public Work or visit the New York State Department of Labor website ([www.labor.ny.gov](http://www.labor.ny.gov)) for current wage rate information.

#### Apprentice Training Ratios

The following are the allowable ratios of registered Apprentices to Journey-workers.

For example, the ratio 1:1,1:3 indicates the allowable initial ratio is one Apprentice to one Journeyworker. The Journeyworker must be in place on the project before an Apprentice is allowed. Then three additional Journeyworkers are needed before a second Apprentice is allowed. The last ratio repeats indefinitely. Therefore, three more Journeyworkers must be present before a third Apprentice can be hired, and so on.

Please call Apprentice Training Central Office at (518) 457-6820 if you have any questions.

Title (Trade)	Ratio
Boilermaker (Construction)	1:1,1:4
Boilermaker (Shop)	1:1,1:3
Carpenter (Bldg.,H&H, Pile Driver/Dockbuilder)	1:1,1:4
Carpenter (Residential)	1:1,1:3
Electrical (Outside) Lineman	1:1,1:2
Electrician (Inside)	1:1,1:3
Elevator/Escalator Construction & Modernizer	1:1,1:2
Glazier	1:1,1:3
Insulation & Asbestos Worker	1:1,1:3
Iron Worker	1:1,1:4
Laborer	1:1,1:3
Mason	1:1,1:4
Millwright	1:1,1:4
Op Engineer	1:1,1:5
Painter	1:1,1:3
Plumber & Steamfitter	1:1,1:3
Roofer	1:1,1:2
Sheet Metal Worker	1:1,1:3
Sprinkler Fitter	1:1,1:2

If you have any questions concerning the attached schedule or would like additional information, please contact the nearest BUREAU of PUBLIC WORK District Office or write to:

New York State Department of Labor  
Bureau of Public Work  
State Office Campus, Bldg. 12  
Albany, NY 12240

District Office Locations:	Telephone #	FAX #
Bureau of Public Work - Albany	518-457-2744	518-485-0240
Bureau of Public Work - Binghamton	607-721-8005	607-721-8004
Bureau of Public Work - Buffalo	716-847-7159	716-847-7650
Bureau of Public Work - Garden City	516-228-3915	516-794-3518
Bureau of Public Work - Newburgh	845-568-5287	845-568-5332
Bureau of Public Work - New York City	212-932-2419	212-775-3579
Bureau of Public Work - Patchogue	631-687-4882	631-687-4902
Bureau of Public Work - Rochester	585-258-4505	585-258-4708
Bureau of Public Work - Syracuse	315-428-4056	315-428-4671
Bureau of Public Work - Utica	315-793-2314	315-793-2514
Bureau of Public Work - White Plains	914-997-9507	914-997-9523
Bureau of Public Work - Central Office	518-457-5589	518-485-1870

**Westchester County General Construction**

**Boilermaker**

**05/01/2022**

**JOB DESCRIPTION** Boilermaker

**DISTRICT 4**

**ENTIRE COUNTIES**

Bronx, Dutchess, Kings, Nassau, New York, Orange, Putnam, Queens, Richmond, Rockland, Suffolk, Sullivan, Ulster, Westchester

**WAGES**

Per Hour: 07/01/2021

Boilermaker \$ 63.38  
Repairs & Renovations 63.38

**SUPPLEMENTAL BENEFITS**

Per Hour: 07/01/2021

Boilermaker 32% of hourly  
Repair \$ Renovations Wage Paid  
+ \$ 25.38

NOTE: "Hourly Wage Paid" shall include any and all premium(s) pay.

Repairs & Renovation Includes replacement of parts and repairs & renovation of existing unit.

**OVERTIME PAY**

See (D, O) on OVERTIME PAGE  
Repairs & Renovation see (B,E,Q)

**HOLIDAY**

Paid: See (8, 16, 23, 24) on HOLIDAY PAGE  
Overtime: See (5, 6, 8, 11, 12, 15, 16, 22, 23, 24, 25) on HOLIDAY PAGE

NOTE: \*Employee must work in pay week to receive Holiday Pay.  
\*\*Employee gets 4 times the hourly wage rate for working Labor Day.

**REGISTERED APPRENTICES**

Wage per hour:  
(1/2) Year Terms at the following percentage of Boilermaker's Wage

1st	2nd	3rd	4th	5th	6th	7th
65%	70%	75%	80%	85%	90%	95%

Supplemental Benefits Per Hour:

Apprentice(s) 07/01/2021  
32% of Hourly  
Wage Paid Plus  
Amount Below

1st Term	\$ 19.41
2nd Term	20.26
3rd Term	21.11
4th Term	21.96
5th Term	22.82
6th Term	23.68
7th Term	24.52

NOTE: "Hourly Wage Paid" shall include any and all premium(s)

4-5

**Carpenter**

**05/01/2022**

**JOB DESCRIPTION** Carpenter

**DISTRICT 8**

**ENTIRE COUNTIES**

Bronx, Kings, Nassau, New York, Putnam, Queens, Richmond, Rockland, Suffolk, Westchester

**WAGES**

Per hour: 07/01/2021

Piledriver \$ 56.93  
Dockbuilder \$ 56.93

**SUPPLEMENTAL BENEFITS**

Per hour:

Journeyworker \$ 53.33

**OVERTIME PAY**

See (B, E2, O) on OVERTIME PAGE

**HOLIDAY**

Paid: See (1) on HOLIDAY PAGE.

Paid: for 1st & 2nd yr.

Apprentices See (5,6,11,13,25)

Overtime: See (5,6,11,13,25) on HOLIDAY PAGE.

**REGISTERED APPRENTICES**

Wages per hour

(1)year terms:

1st	2nd	3rd	4th
\$23.37	\$28.97	\$37.35	\$45.74

Supplemental benefits per hour:

All Terms: \$ 35.33

8-1556 Db

**Carpenter**

**05/01/2022**

**JOB DESCRIPTION** Carpenter

**DISTRICT 8**

**ENTIRE COUNTIES**

Bronx, Kings, Nassau, New York, Queens, Richmond, Rockland, Suffolk, Westchester

**WAGES**

Per hour: 07/01/2021

Carpet/Resilient

Floor Coverer \$ 54.75

INCLUDES HANDLING & INSTALLATION OF ARTIFICIAL TURF AND SIMILAR TURF INDOORS/OUTDOORS.

**SUPPLEMENTAL BENEFITS**

Per hour:

\$ 46.97

**OVERTIME PAY**

See (B, E, Q) on OVERTIME PAGE

**HOLIDAY**

Paid: See (18, 19) on HOLIDAY PAGE.

Paid for 1st & 2nd yr.

Apprentices See (5,6,11,13,16,18,19,25)

Overtime: See (5,6,11,13,16,18,19,25) on HOLIDAY PAGE.

**REGISTERED APPRENTICES**

Wage per hour - (1) year terms:

1st	2nd	3rd	4th
\$ 24.55	\$ 27.55	\$ 31.80	\$ 39.68

Supplemental benefits per hour:

1st	2nd	3rd	4th
\$ 16.19	\$ 17.69	\$ 21.29	\$ 23.29

8-2287

**Carpenter**

**05/01/2022**

**JOB DESCRIPTION** Carpenter

**DISTRICT 8**

**ENTIRE COUNTIES**

Bronx, Dutchess, Kings, Nassau, New York, Orange, Putnam, Queens, Richmond, Rockland, Suffolk, Westchester

**WAGES**

Per Hour: 07/01/2021

Marine Construction:

Marine Diver \$ 71.80  
Marine Tender 51.34

**SUPPLEMENTAL BENEFITS**

Per Hour:

Journeyworker \$ 53.33

**OVERTIME PAY**

See (B, E, E2, Q) on OVERTIME PAGE

**HOLIDAY**

Paid: See (18, 19) on HOLIDAY PAGE  
Overtime: See (5, 6, 10, 11, 13, 16, 18, 19) on HOLIDAY PAGE

**REGISTERED APPRENTICES**

Wages per hour:  
One (1) year terms.

1st year \$ 23.37  
2nd year 28.97  
3rd year 37.35  
4th year 45.74

Supplemental Benefits  
Per Hour:

All terms \$ 35.33

8-1456MC

**Carpenter**

**05/01/2022**

**JOB DESCRIPTION** Carpenter

**DISTRICT 8**

**ENTIRE COUNTIES**

Bronx, Kings, Nassau, New York, Putnam, Queens, Richmond, Rockland, Suffolk, Westchester

**WAGES**

Per hour: 07/01/2021

Building  
Millwright \$ 57.00

**SUPPLEMENTAL BENEFITS**

Per hour:

Millwright \$ 54.60

**OVERTIME PAY**

See (B, E, Q) on OVERTIME PAGE

**HOLIDAY**

Paid: See (18,19) on HOLIDAY PAGE.

Overtime See (5,6,8,11,13,18,19,25) on HOLIDAY PAGE.

**REGISTERED APPRENTICES**

Wages per hour:  
One (1) year terms:

1st.	2nd.	3rd.	4th.
\$30.74	\$36.19	\$41.64	\$52.54

Supplemental benefits per hour:  
One (1) year terms:

1st.	2nd.	3rd.	4th.
------	------	------	------

\$35.03      \$38.73      \$43.08      \$49.84

8-740.1

**Carpenter**

**05/01/2022**

**JOB DESCRIPTION** Carpenter

**DISTRICT 8**

**ENTIRE COUNTIES**

Bronx, Kings, Nassau, New York, Queens, Richmond, Suffolk, Westchester

**WAGES**

Per Hour:

07/01/2021

Timberman

\$ 52.05

**SUPPLEMENTAL BENEFITS**

Per Hour:

07/01/2021

\$ 52.78

**OVERTIME PAY**

See (B, E, E2, Q) on OVERTIME PAGE

**HOLIDAY**

Paid: See (1) on HOLIDAY PAGE.

Paid: for 1st & 2nd yr.

Apprentices See (5,6,11,13,25)

Overtime:

See (5,6,11,13,25) on HOLIDAY PAGE.

**REGISTERED APPRENTICES**

Wages per hour:

One ( 1 ) year terms:

1st	2nd	3rd	4th
\$21.42	\$26.53	\$34.18	\$41.84

Supplemental benefits per hour:

All terms \$ 35.06

8-1556 Tm

**Carpenter**

**05/01/2022**

**JOB DESCRIPTION** Carpenter

**DISTRICT 8**

**ENTIRE COUNTIES**

Bronx, Kings, Nassau, New York, Queens, Richmond, Rockland, Westchester

**PARTIAL COUNTIES**

Orange: South of but including the following, Waterloo Mills, Slate Hill, New Hampton, Goshen, Blooming Grove, Mountainville, east to the Hudson River.

Putnam: South of but including the following, Cold Spring, TompkinsCorner, Mahopac, Croton Falls, east to Connecticut border.

Suffolk: West of Port Jefferson and Patchogue Road to Route 112 to the Atlantic Ocean.

**WAGES**

Per hour:

07/01/2021

10/18/2021

Core Drilling:

Driller

\$ 41.74

\$ 42.27

Driller Helper

32.92

33.47

Note: Hazardous Waste Pay Differential:

For Level C, an additional 10% above wage rate per hour

For Level B, an additional 10% above wage rate per hour

For Level A, an additional 10% above wage rate per hour

Note: When required to work on water: an additional \$ 0.50 per hour.

**SUPPLEMENTAL BENEFITS**

Per hour:

Driller and Helper

\$ 29.40

\$ 30.60

**OVERTIME PAY**

OVERTIME: See (B,E,K\*,P,R\*\*) on OVERTIME PAGE.

**HOLIDAY**

Paid: See (5,6) on HOLIDAY PAGE.

Overtime: \* See (5,6) on HOLIDAY PAGE.

\*\* See (8,10,11,13) on HOLIDAY PAGE.

8-1536-CoreDriller

**Carpenter - Building / Heavy&Highway**

**05/01/2022**

**JOB DESCRIPTION** Carpenter - Building / Heavy&Highway

**DISTRICT** 11

**ENTIRE COUNTIES**

Putnam, Rockland, Westchester

**WAGES**

WAGES:(per hour)

07/01/2021

BUILDING/HEAVY & HIGHWAY/TUNNEL:

Carpenter

Base Wage

\$ 37.69

+ \$7.63\*

\*For all hours paid straight or premium.

SHIFT DIFFERENTIAL: When it is mandated by a Government Agency irregular or off shift can be worked. The Carpenter shall receive an additional fifteen percent (15%) of wage plus applicable benefits.

NOTE:Carpenters employed in the removal or abatement of asbestos or any toxic or hazardous material or required to work near asbestos or any toxic or hazardous material and required to wear protective equipment shall receive two (2) hours extra pay per day, plus applicable supplemental benefits.

**SUPPLEMENTAL BENEFITS**

Per hour:

Journeyworker

\$ 31.91

**OVERTIME PAY**

BUILDING:

See ( B, E, Q ) on OVERTIME PAGE.

HEAVY&HIGHWAY/TUNNEL:

See ( B, E, P, \*R, \*\*T, X ) on OVERTIME PAGE.

\*R applies to Heavy&Highway/Tunnel Overtime Holiday Code 25 with benefits at straight time rate.

\*\*T applies to Heavy&Highway/Tunnel Overtime Holiday Codes 5 & 6 with benefits at straight time rate.

**HOLIDAY**

BUILDING:

Paid: See ( 1 ) on HOLIDAY PAGE.

Overtime: See ( 5, 6, 16, 25 ) on HOLIDAY PAGE.

Holidays that fall on Sunday will be observed Monday.

HEAVY&HIGHWAY/TUNNEL:

Paid: See ( 5, 6, 25 ) on HOLIDAY PAGE including benefits.

Overtime: See ( 5, 6, 25 ) on HOLIDAY PAGE.

**REGISTERED APPRENTICES**

1 year terms at the following wage rates:

Indentured before July 1 2016

1st	2nd	3rd	4th
\$ 18.85	\$ 22.61	\$ 26.38	\$ 30.15
+3.57*	+3.57*	+3.57*	+3.57*

Indentured after July 1 2016

1st	2nd	3rd	4th	5th
\$ 18.85	\$ 22.61	\$ 24.50	\$ 26.38	\$ 30.15
+3.57*	+3.57*	+3.57*	+3.57*	+3.57*

\*For all hours paid straight or premium

SUPPLEMENTAL BENEFITS per hour:



All terms \$ 16.28

11-279.1B/HH

**Electrician** **05/01/2022**

**JOB DESCRIPTION** Electrician

**DISTRICT 9**

**ENTIRE COUNTIES**

Bronx, Kings, New York, Queens, Richmond, Westchester

**WAGES**

Per hour: 07/01/2021

Service Technician \$ 34.40

Service and Maintenance on Alarm and Security Systems.

Maintenance, repair and /or replacement of defective (or damaged) equipment on, but not limited to, Burglar - Fire - Security - CCTV - Card Access - Life Safety Systems and associated devices. (Whether by service contract of T&M by customer request.)

**SUPPLEMENTAL BENEFITS**

Per hour:  
 Journeyworker: \$ 19.32

**OVERTIME PAY**

See (B, E, Q) on OVERTIME PAGE

**HOLIDAY**

Paid: See (5, 6, 11, 15, 16, 17, 25, 26) on HOLIDAY PAGE  
 Overtime: See (5, 6, 11, 15, 16, 17, 25, 26) on HOLIDAY PAGE

9-3H

**Electrician** **05/01/2022**

**JOB DESCRIPTION** Electrician

**DISTRICT 8**

**ENTIRE COUNTIES**

Westchester

**WAGES**

Per hour: 07/01/2021 04/21/2022

\*Electrician/A-Technician \$ 53.75 \$ 53.75

Teledata 53.75 53.75

\*All new installations of wiring, conduit, junction boxes and light fixtures for projects with a base bid of more than \$325,000. For projects with a base bid of \$325,000 or less, see Maintenance and Repair rates.

Note: On a job where employees are required to work on bridges over navigable waters, transmission towers, light poles, bosun chairs, swinging scaffolds , etc. 40 feet or more above the water or ground or under compressed air, or tunnel projects under construction or where assisted breathing apparatus is required, they will be paid at the rate of time and one-half for such work except on normal pole line or building construction work.

**SUPPLEMENTAL BENEFITS**

Per hour:  
 Journeyworker \$ 52.73 \$ 54.39

**OVERTIME PAY**

See (A, G, \*J, P) on OVERTIME PAGE

\*NOTE: Emergency work on Sunday and Holidays is at the time and one-half overtime rate.

**HOLIDAY**

Paid: See (1) on HOLIDAY PAGE  
 Overtime: See (5, 6, 8, 11, 15, 16, 25) on HOLIDAY PAGE

**REGISTERED APPRENTICES**

(1) year terms at the following wage rates:

	07/01/2021	01/01/2022	04/21/2022
1st term	\$ 14.00	\$ 15.00	\$ 15.00
2nd term	16.00	16.00	16.00
3rd term	18.00	18.00	18.00
4th term	20.00	20.00	20.00
MIJ 1-12 months	24.00	24.00	25.00
MIJ 13-18 months	27.50	27.50	28.50

Supplemental Benefits per hour:

	07/01/2021	04/21/2022
1st term	\$ 10.15	\$ 10.82
2nd term	13.05	13.05
3rd term	14.39	14.39
4th term	15.72	15.72
MIJ 1-12 months	13.39	13.49
MIJ 13-18 months	13.76	13.87

8-3/W

**Electrician**

**05/01/2022**

**JOB DESCRIPTION** Electrician

**DISTRICT 8**

**ENTIRE COUNTIES**

Westchester

**WAGES**

	07/01/2021	04/21/2022
Electrician -M	\$ 27.50	\$28.50
H - Telephone	\$ 27.50	\$28.50

All work with a base bid amount of \$325,000 or less. Including repairs and /or replacement of defective electrical and teledata equipment, all work necessary to retrofit, service, maintain and repair all kinds of lighting fixtures and local lighting controls, and washing and cleaning of foregoing fixtures.

\*If the project exceeds \$375,000 due to changes in the scope of work, an Electrician/A Technician must be part of the labor ratio.

**SUPPLEMENTAL BENEFITS**

	07/01/2021	04/21/2022
Electrician & H - Telephone	\$ 13.76	\$13.87

**OVERTIME PAY**

See (B, G, \*J, P) on OVERTIME PAGE

\*Note: Emergency work on Sunday and Holidays is at the time and one-half overtime rate.

**HOLIDAY**

Paid: See (1) on HOLIDAY PAGE  
 Overtime: See (5, 6, 8, 11, 15, 16, 25) on HOLIDAY PAGE

8-3m

**Elevator Constructor**

**05/01/2022**

**JOB DESCRIPTION** Elevator Constructor

**DISTRICT 4**

**ENTIRE COUNTIES**

Bronx, Kings, Nassau, New York, Queens, Richmond, Suffolk

**PARTIAL COUNTIES**

Rockland: Entire County except for the Township of Stony Point

Westchester: Entire County except for the Townships of Bedford, Lewisboro, Cortland, Mt. Kisco, North Salem, Pound Ridge, Somers and Yorktown.

**WAGES**

Per hour:	07/01/2021	03/17/2022
Elevator Constructor	\$ 72.29	\$ 75.14
Modernization & Service/Repair	56.77	59.09

Four(4), ten(10) hour days may be worked at straight time during a week, Monday thru Friday.

NOTE- In order to use the '4 Day/10 Hour Work Schedule', as your normal schedule, you must submit an 'Employer Registration for Use of 4 Day/10 Hour Work Schedule' form PW30.1; and there must be a dispensation of hours in place on the project. If the PW30.1 IS NOT SUBMITTED you will be liable for overtime payments for work over the allotted hours per day listed.

**SUPPLEMENTAL BENEFITS**

Per Hour:

Elevator Constructor	\$ 41.92	\$ 43.914
Modernization & Service/Repairs	41.082	42.787

**OVERTIME PAY**

Constructor See ( D, M, T ) on OVERTIME PAGE.

Modern/Service See ( B, F, S ) on OVERTIME PAGE.

**HOLIDAY**

Paid: See (5, 6, 8, 11, 15, 16, 25) on HOLIDAY PAGE  
 Overtime: See (5, 6, 8, 11, 15, 16, 25) on HOLIDAY PAGE

**REGISTERED APPRENTICES**

WAGES PER HOUR:

\*Note: 1st, 2nd, 3rd Terms are based on Average wage of Constructor & Modernization.  
 Terms 4 thru 9 Based on Journeymans wage of classification Working in.

**6 MONTH TERMS:**

1st Term* 50%	2nd & 3rd Term* 50%	4th & 5th Term 55%	6th & 7th Term 65%	8th & 9th Term 75%
------------------	------------------------	-----------------------	-----------------------	-----------------------

**SUPPLEMENTAL BENEFITS**

Elevator Constructor		
1st Term	\$ 0.00	\$ 0.00
2nd & 3rd Term	34.05	34.772
4th & 5th Term	34.91	35.606
6th & 7th Term	36.30	37.052
8th & 9th Term	37.70	38.497

Modernization & Service/Repair		
1st Term	\$ 0.00	\$ 0.00
2nd & 3rd Term	34.00	34.672
4th & 5th Term	34.50	35.195
6th & 7th Term	35.83	36.571
8th & 9th Term	37.15	37.938

4-1

---

**Elevator Constructor** **05/01/2022**

---

**JOB DESCRIPTION** Elevator Constructor

**DISTRICT 1**

**ENTIRE COUNTIES**

Columbia, Dutchess, Greene, Orange, Putnam, Sullivan, Ulster

**PARTIAL COUNTIES**

Delaware: Towns of Andes, Bovina, Colchester, Davenport, Delhi, Harpersfield, Hemdon, Kortright, Meredith, Middletown, Roxbury, Hancock & Stamford

Rockland: Only the Township of Stony Point.

Westchester: Only the Townships of Bedford, Lewisboro, Cortland, Mt. Kisco, North Salem, Pound Ridge, Somers and Yorktown.

**WAGES**

Per Hour	07/01/2021	01/01/2022
Mechanic	\$ 62.51	\$ 64.63
Helper	70% of Mechanic Wage Rate	70% of Mechanic Wage Rate

Four (4), ten (10) hour days may be worked for New Construction and Modernization Work at straight time during a week, Monday thru Thursday or Tuesday thru Friday.

\*\*\*Four (4), ten (10) hour days are not permitted for Contract Work/Repair Work

NOTE - In order to use the '4 Day/10 Hour Work Schedule' as your normal schedule, you must submit an 'Employer Registration for Use of 4 Day/10 Hour Work Schedule', form PW30.1; and there must be a dispensation of hours in place on the project. If the PW30.1 is not submitted you may be liable for overtime payments for work over 8 hours per day.

**SUPPLEMENTAL BENEFITS**

Per hour	07/01/2021	01/01/2022
Journeyman/Helper	\$ 35.825*	\$ 36.885*

(\*)Plus 6% of regular hourly if less than 5 years of service. Plus 8% of regular hourly rate if more than 5 years of service.

**OVERTIME PAY**

See (D, O) on OVERTIME PAGE

**HOLIDAY**

Paid: See (5, 6, 15, 16) on HOLIDAY PAGE

Overtime: See (5, 6, 15, 16) on HOLIDAY PAGE

Note: When a paid holiday falls on Saturday, it shall be observed on Friday. When a paid holiday falls on Sunday, it shall be observed on Monday.

**REGISTERED APPRENTICES**

Wages per hour:

0-6 mo*	6-12 mo	2nd yr	3rd yr	4th yr
50 %	55 %	65 %	70 %	80 %

(\*)Plus 6% of the hourly rate, no additional supplemental benefits.

Supplemental Benefits per hour worked:

Same as Journeyman/Helper

1-138

**Glazier**

**05/01/2022**

**JOB DESCRIPTION** Glazier

**DISTRICT 8**

**ENTIRE COUNTIES**

Bronx, Dutchess, Kings, Nassau, New York, Orange, Putnam, Queens, Richmond, Rockland, Suffolk, Sullivan, Ulster, Westchester

**WAGES**

Per hour:	7/01/2021	11/01/2021
Glazier	\$ 58.60	\$ 59.10
*Scaffolding	59.55	60.55
Glass Tinting & Window Film	29.60	29.60
**Repair & Maintenance	29.60	29.60

\*Scaffolding includes swing scaffold, mechanical equipment, scissor jacks, man lifts, booms & buckets 24' or more, but not pipe scaffolding.

\*\*Repair & Maintenance- All repair & maintenance work on a particular building, whenever performed, where the total cumulative contract value is under \$148,837. All Glass tinting, window film, regardless of material or intended use, and all affixing of decals to windows or glass.

**SUPPLEMENTAL BENEFITS**

Per hour:	7/01/2021	11/01/2021
Journeyworker	\$ 36.04	\$ 36.79
Glass tinting & Window Film	21.19	21.19
Repair & Maintenance	21.19	21.19

**OVERTIME PAY**

See (B,H,V) on OVERTIME PAGE.

For 'Repair & Maintenance' and 'Glass Tinting & Window Film' see (B, B2, I, S) on overtime page.

**HOLIDAY**

Paid: See (1) on HOLIDAY PAGE

Overtime: See (4, 6, 16, 25) on HOLIDAY PAGE

For 'Repair & Maintenance' and 'Glass Tinting & Window Film' Only

Paid: See(5, 6, 16, 25)

Overtime: See(5, 6, 16, 25)

**REGISTERED APPRENTICES**

Wage per hour:

(1) year terms at the following wage rates:

7/01/2021	11/01/2021
-----------	------------

1st term	\$ 20.72	\$ 21.00
2nd term	28.66	28.87
3rd term	34.67	34.94
4th term	46.62	47.01

Supplemental Benefits:

(Per hour)		
1st term	\$ 16.58	\$ 16.80
2nd term	23.57	23.99
3rd term	26.09	26.57
4th term	30.91	31.52

8-1087 (DC9 NYC)

**Insulator - Heat & Frost**

**05/01/2022**

**JOB DESCRIPTION** Insulator - Heat & Frost

**DISTRICT 8**

**ENTIRE COUNTIES**

Dutchess, Orange, Putnam, Rockland, Westchester

**WAGES**

Per hour:	07/01/2021	05/31/2022
Insulator	\$ 56.25	+ \$ 2.00
Discomfort & Additional Training**	59.22	+ \$ 2.00
Fire Stop Work*	30.07	+ \$ 2.00

\* Applies on all exclusive Fire Stop Work (When contract is for Fire Stop work only). No apprentices on these contracts only.

\*\*Applies to work requiring: garb or equipment worn against the body not customarily worn by insulators; psychological evaluation; special training, including but not limited to "Yellow Badge" radiation training

Note: Additional \$0.50 per hour for work 30 feet or more above floor or ground level.

**SUPPLEMENTAL BENEFITS**

Per hour:	
Journeyworker	\$ 35.10
Discomfort & Additional Training	37.06
Fire Stop Work:	
Journeyworker	17.90

**OVERTIME PAY**

See (B, E, E2, Q, \*T) on OVERTIME PAGE

**HOLIDAY**

Paid: See (1) on HOLIDAY PAGE

Note: Last working day preceding Christmas and New Years day, workers shall work no later than 12:00 noon and shall receive 8 hrs pay.

Overtime: See ( 2\*, 4, 6, 16, 25 ) on HOLIDAY PAGE.

\*Note: Labor Day triple time if worked.

**REGISTERED APPRENTICES**

(1) year terms:

Insulator Apprentices:			
1st	2nd	3rd	4th
\$ 30.07	\$ 35.30	\$ 40.54	\$ 45.78

Discomfort & Additional Training Apprentices:

1st	2nd	3rd	4th
\$ 31.55	\$ 37.08	\$ 42.61	\$ 48.16

Supplemental Benefits paid per hour:

Insulator Apprentices:

1st term	\$ 17.90
2nd term	21.35
3rd term	24.79
4th term	28.23

Discomfort & Additional Training Apprentices:

1st term	\$ 18.89
2nd term	22.52
3rd term	26.16
4th term	29.80

8-91

---

**Ironworker** **05/01/2022**

**JOB DESCRIPTION** Ironworker **DISTRICT 9**

**ENTIRE COUNTIES**  
 Bronx, Kings, Nassau, New York, Queens, Richmond, Suffolk, Westchester

**WAGES**  
 Per Hour: 07/01/2021

Ironworker Rigger \$ 67.99

Ironworker Stone  
 Derrickman \$ 67.99

**SUPPLEMENTAL BENEFITS**  
 Per hour: \$ 41.44

**OVERTIME PAY**  
 See (B, D1, \*E, Q, \*\*V) on OVERTIME PAGE  
 \*Time and one-half shall be paid for all work on Saturday up to eight (8) hours and double time shall be paid for all work thereafter.  
 \*\* Benefits same premium as wages on Holidays only

**HOLIDAY**  
 Paid: See (18) on HOLIDAY PAGE  
 Overtime: See (5, 6, 8, 25) on HOLIDAY PAGE  
 \*Work stops at schedule lunch break with full day's pay.

**REGISTERED APPRENTICES**  
 Wage per hour:

1/2 year terms at the following hourly wage rate:

	1st	2nd	3rd	4th
07/01/2021	\$33.55	\$47.94	\$53.34	\$58.74

Supplemental benefits:

Per hour:				
07/01/2021	\$21.18	\$31.45	\$31.45	\$31.45

9-197D/R

---

**Ironworker** **05/01/2022**

**JOB DESCRIPTION** Ironworker **DISTRICT 4**

**ENTIRE COUNTIES**  
 Bronx, Kings, Nassau, New York, Queens, Richmond, Suffolk, Westchester

**WAGES**  
 Per Hour: 07/01/2021 01/01/2022

Ornamental	\$ 46.15	\$ 46.40
Chain Link Fence	46.15	46.40
Guide Rail	46.15	46.40

**SUPPLEMENTAL BENEFITS**  
 Per hour:  
 Journeyworker: \$ 60.05 \$ 61.05

**OVERTIME PAY**  
 See (B, B1, Q, V) on OVERTIME PAGE

**HOLIDAY**

Paid: See (1) on HOLIDAY PAGE  
 Overtime: See (5, 6, 25) on HOLIDAY PAGE

**REGISTERED APPRENTICES**

Apprentices Hired after 9/1/18:

1 year terms			
1st Term	\$ 20.63		\$21.13
2nd Term	24.22		24.77
3rd Term	27.80		28.40
4th Term	31.38		32.06

Supplemental Benefits per hour:

1st Term	\$ 17.89		\$ 17.89
2nd Term	19.14		19.14
3rd Term	20.40		20.40
4th Term	21.66		21.66

4-580-Or

**Ironworker**

**05/01/2022**

**JOB DESCRIPTION** Ironworker

**DISTRICT 4**

**ENTIRE COUNTIES**

Bronx, Kings, Nassau, New York, Queens, Richmond, Suffolk, Westchester

**WAGES**

PER HOUR:

07/01/2021 01/01/2022

Ironworker:

Structural	\$ 54.20	\$ 54.95
Bridges		
Machinery		

**SUPPLEMENTAL BENEFITS**

PER HOUR PAID:

Journeyman	\$ 83.35	\$ 84.35
------------	----------	----------

**OVERTIME PAY**

See (B, B1, Q, \*V) on OVERTIME PAGE

\*NOTE: Benefits are calculated for every hour paid

**HOLIDAY**

Paid: See (1) on HOLIDAY PAGE  
 Overtime: See (5, 6, 18, 19) on HOLIDAY PAGE

**REGISTERED APPRENTICES**

WAGES PER HOUR:

6 month terms at the following rate:

1st	\$28.21	\$28.59
2nd	\$28.81	\$29.19
3rd - 6th	\$29.42	\$29.80

Supplemental Benefits

PER HOUR PAID:

All Terms	\$56.90	\$58.42
-----------	---------	---------

4-40/361-Str

**Ironworker**

**05/01/2022**

**JOB DESCRIPTION** Ironworker

**DISTRICT 4**

**ENTIRE COUNTIES**

Bronx, Kings, Nassau, New York, Queens, Richmond, Suffolk, Westchester

**PARTIAL COUNTIES**

Rockland: Southern section - south of Convent Road and east of Blue Hills Road.

**WAGES**

Per hour: 07/01/2021

Reinforcing & Metal Lathing	\$ 56.25
"Base" Wage	\$ 54.70 plus \$ 1.55

"Base" Wage is used to calculate overtime hours only.

**SUPPLEMENTAL BENEFITS**

Per hour:

Reinforcing & Metal Lathing	\$ 38.30
-----------------------------	----------

**OVERTIME PAY**

See (B, E, Q, \*X) on OVERTIME PAGE

\*Only \$22.00 per Hour for non worked hours

Supplemental Benefit Premiums for Overtime Hours worked:

Time & One Half	\$ 45.08
Double Time	\$ 51.33

**HOLIDAY**

Paid: See (1) on HOLIDAY PAGE  
 Overtime: See (5, 6, 11, 13, 18, 19, 25) on HOLIDAY PAGE

**REGISTERED APPRENTICES**

(1) year terms at the following wage rates:

1st term	2nd term	3rd term	4th Term
Wage Per Hour: \$ 22.55	\$ 28.38	\$ 34.68	\$ 37.18
"Base" Wage \$ 21.00 plus \$1.55	\$ 26.80 plus \$1.58	\$ 33.10 plus \$1.58	\$ 35.60 plus \$1.58

"Base" Wage is used to calculate overtime hours ONLY.

**SUPPLEMENTAL BENEFITS**

Per Hour:

1st term	2nd term	3rd term	4th Term
\$ 18.17	\$ 21.34	\$ 22.00	\$ 20.50

4-46Reinf

**Laborer - Building**

**05/01/2022**

**JOB DESCRIPTION** Laborer - Building

**DISTRICT 8**

**ENTIRE COUNTIES**

Putnam, Westchester

**WAGES**

07/01/2021

Laborer \$ 36.40  
plus \$5.05\*\*

Laborer - Asbestos & Hazardous Materials Removal \$ 43.10\*

\* Abatement/Removal of:

- Lead based or lead containing paint on materials to be repainted is classified as Painter.
- Asbestos containing roofs and roofing material is classified as Roofer.

\*\* This portion is not subject to overtime premium.

NOTE: Upgrade/Material condition work plan for work performed during non-outage under a wage formula of 90% wage/100% fringe benefits at nuclear power plants.



**SUPPLEMENTAL BENEFITS**

Per hour: 07/01/2021

Journeyworker \$ 27.50

**OVERTIME PAY**

See (B, E, E2, Q, \*V) on OVERTIME PAGE

\*Note: For Sundays and Holidays worked benefits are at the same premium as wages.

**HOLIDAY**

Paid: See (1) on HOLIDAY PAGE

Overtime: See (5, 6, 16, 25) on HOLIDAY PAGE

**REGISTERED APPRENTICES**

LABORER ONLY

Hourly terms at the following wage:

Level A	Level B	Level C	Level D
0-1000	1001-2000	2001-3000	3001-4000
\$ 21.04	\$ 24.86	\$ 28.69	\$ 32.51

Supplemental Benefits per hour:

Apprentices  
 All terms \$ 21.15

8-235/B

**Laborer - Heavy&Highway**

**05/01/2022**

**JOB DESCRIPTION** Laborer - Heavy&Highway

**DISTRICT 8**

**ENTIRE COUNTIES**

Putnam, Westchester

**WAGES**

\*\*PUTNAM: APPLIES TO ALL HEAVY & HIGHWAY WORK EXCLUDING HIGHWAYS, STREETS, AND BRIDGES\*\*

GROUP I: Blaster, Quarry Master, Curbs/Asphalt Screedman, Pipe Jacking and Boring Operations Operator, Qualified Dead Condition Pipe Fuser (B Mechanic)

GROUP II: Burner, Drillers(jumbo, joy, wagon, air track, hydraulic), Drill Operator, Self Contained Rotary Drill, Curbs, Raker, Bar Person, Concrete Finisher.

GROUP III: Pavement Breakers, Jeeper Operator, Jack Hammer, Pneumatic Tools (all), Gas Driller, Guniting, Railroad Spike Puller, Pipelayer, Chain Saw, Deck winches on scows, Power Buggy Operator, Power Wheelbarrow Operator, Bar Person Helper, Compressed Airlance, Water Jet Lance.

GROUP IV: Concrete Laborers, Asph. Worker, Rock Scaler, Vibrator Oper., Bit Grinder, Air Tamper, Pumps, Epoxy (adhesives, fillers and troweled on), Barco Rammer, Concrete Grinder, Crack Router Operator, Guide Rail-digging holes and placing concrete and demolition when not to be replaced, distribution of materials and tightening of bolts.

GROUP V: Drillers Helpers, Common Laborer, Mason Tenders, Signal Person, Pit Person, Truck Spotter, Powder Person, Landscape/Nursery Person, Dump Person, Temp. Heat.

GROUP VIA: Asbestos/Toxic Waste Laborer-All removal (Roads, Tunnels, Landfills, etc.) Confined space laborer, Bio-remediation, Phyto-remediation, Lead or Hazardous material, Abatement Laborer.

Wages:(per hour) 07/01/2021

GROUP I	\$45.65*
GROUP II	44.30*
GROUP III	43.90*
GROUP IV	43.55*
GROUP V	43.20*
GROUP VIA	45.20*
Operator Qualified	
Gas Mechanic(A Mech)	55.65*
Flagperson	36.85*

\*NOTE: To calculate overtime premiums, deduct \$0.10 from above wages

SHIFT WORK: A shift premium will be paid on Public Work contracts for off-shift or irregular shift work when mandated by the NYS D.O.T. or other Governmental Agency contracts. Employees shall receive an additional 15% per hour above current rate for all regular and irregular shift work. Premium pay shall be calculated using the 15% per hour differential as base rate.

**SUPPLEMENTAL BENEFITS**

Per hour:

Journeyworker:

First 40 Hours	
Per Hour	\$26.10
Over 40 Hours	
Per Hour	19.85

**OVERTIME PAY**

See (B, E, P, R, S) on OVERTIME PAGE

**HOLIDAY**

Paid: See (5, 6, 8, 15, 25, 26) on HOLIDAY PAGE

Overtime: See (5, 6, 8, 15, 25, 26) on HOLIDAY PAGE

NOTE: For Holiday Overtime: 5, 6 - Code 'S' applies  
 For Holiday Overtime: 8, 15, 25, 26 - Code 'R' applies

**REGISTERED APPRENTICES**

	1st term	2nd term	3rd term	4th term
	1-1000hrs	1001-2000hrs	2001-3000hrs	3001-4000hrs
07/01/2021	\$ 24.56	\$ 28.98	\$ 33.40	\$ 37.72

Supplemental Benefits per hour:

1st term	\$ 4.70 - After 40 hours: \$ 4.45
2nd term	\$ 4.80 - After 40 hours: \$ 4.45
3rd term	\$ 5.30 - After 40 hours: \$ 4.85
4th term	\$ 5.85 - After 40 hours: \$ 5.35

8-60H/H

**Laborer - Tunnel**

**05/01/2022**

**JOB DESCRIPTION** Laborer - Tunnel

**DISTRICT** 11

**ENTIRE COUNTIES**

Columbia, Dutchess, Greene, Orange, Otsego, Putnam, Rockland, Sullivan, Ulster, Westchester

**PARTIAL COUNTIES**

Chenango: Townships of Columbus, Sherburne and New Berlin.

Delaware: Townships of Andes, Bovina, Middletown, Roxbury, Franklin, Hamden, Stamford, Delhi, Kortright, Harpersfield, Merideth and Davenport.

**WAGES**

Class 1: All support laborers/sandhogs working above the shaft or tunnel.

Class 2: All laborers/sandhogs working in the shaft or tunnel.

Class 4: Safety Miners

Class 5: Site work related to Shaft/Tunnel

WAGES: (per hour)

	07/01/2021	07/01/2022
Class 1	\$ 51.95	\$ 53.45
Class 2	54.10	55.60
Class 4	60.50	62.00
Class 5	43.50	44.80

Toxic and hazardous waste, lead abatement and asbestos abatement work will be paid an additional \$ 3.00 an hour.

SHIFT DIFFERENTIAL...On all Government mandated irregular shift work:

- Employee shall be paid at time and one half the regular rate Monday through Friday.
- Saturday shall be paid at 1.65 times the regular rate.
- Sunday shall be paid at 2.15 times the regular rate.

**SUPPLEMENTAL BENEFITS**

Per hour:

Benefit 1	\$ 33.25	\$ 34.45
-----------	----------	----------

Benefit 2	49.81	51.60
Benefit 3	66.35	68.75

Benefit 1 applies to straight time hours, paid holidays not worked.  
 Benefit 2 applies to over 8 hours in a day (M-F), irregular shift work hours worked, and Saturday hours worked.  
 Benefit 3 applies to Sunday and Holiday hours worked.

**OVERTIME PAY**

See (B, E, Q, X) on OVERTIME PAGE

**HOLIDAY**

Paid: See (5, 6, 15, 25) on HOLIDAY PAGE  
 Overtime: See (5, 6, 15, 16, 25) on HOLIDAY PAGE

When a recognized Holidays falls on Saturday or Sunday, holidays falling on Saturday shall be recognized or observed on Friday and holidays falling on Sunday shall be recognized or observed on Monday. Employees ordered to work on the Saturday or Sunday of the holiday or on the recognized or the observed Friday or Monday for those holidays falling on Saturday or Sunday shall receive double time the established rate and benefits for the holiday.

**REGISTERED APPRENTICES**

FOR APPRENTICE RATES, refer to the appropriate Laborer Heavy & Highway wage rate contained in the wage schedule for the County and location where the work is to be performed.

11-17/60/235/754Tun

**Lineman Electrician**

**05/01/2022**

**JOB DESCRIPTION** Lineman Electrician

**DISTRICT 6**

**ENTIRE COUNTIES**

Westchester

**WAGES**

Below rates apply to electrical overhead and underground distribution and maintenance work and overhead and underground transmission line work, electrical substations, switching structures, continuous pipe-type underground fluid or gas filled transmission conduit and cable installations, maintenance jobs or projects, railroad catenary installations and maintenance, third rail installations, the bonding of rails and the installation of fiber optic cable. (Ref #14.04.01)

Includes Teledata Work performed within ten (10) feet of high voltage (600 volts or over) transmission lines.

Per hour:	07/01/2021	05/02/2022	05/01/2023	05/06/2024
Lineman, Tech, Welder	\$ 57.71	\$ 59.01	\$ 60.41	\$ 61.91
Crane, Crawler Backhoe	57.71	59.01	60.41	61.91
Cable Splicer-Pipe Type	63.48	64.91	66.45	68.10
Digging Mach Operator	51.94	53.11	54.37	55.72
Cert. Welder-Pipe Type	60.60	61.96	63.43	65.01
Tractor Trailer Driver	49.05	50.16	51.35	52.62
Groundman, Truck Driver	46.17	47.21	48.33	49.53
Equipment Mechanic	46.17	47.21	48.33	49.53
Flagman	34.63	35.41	36.25	37.15

Additional \$1.00 per hour for entire crew when a helicopter is used.

NOTE: THE FOLLOWING RATES WILL APPLY ON ALL CONTRACTING AGENCY MANDATED MULTIPLE SHIFTS OF AT LEAST FIVE (5) DAYS DURATION WORKED BETWEEN THE HOURS LISTED BELOW:

1ST SHIFT	8:00 AM TO 4:30 PM REGULAR RATE
2ND SHIFT	4:30 PM TO 1:00 AM REGULAR RATE PLUS 17.3%
3RD SHIFT	12:30 AM TO 9:00 AM REGULAR RATE PLUS 31.4%

Four (4), ten (10) hour days may be worked at straight time during a week, Monday thru Thursday. Friday may be used as a make-up day. Tuesday thru Friday may be worked with no make-up day.

NOTE - In order to use the '4 Day/10 Hour Work schedule', as your normal schedule, you must submit an 'Employer Registration for Use of 4 Day/10 Hour Work Schedule,' form PW30.1; and there must be a dispensation of hours in place on the project. If the PW30.1 is not submitted you may be liable for overtime payments for work over 8 hours per day.

**SUPPLEMENTAL BENEFITS**

Per hour worked (but also required on non-worked holidays):

\$25.40	\$ 25.90	\$ 26.40	\$ 26.90
*plus 7% of hourly Wage	*plus 7% of hourly wage	*plus 7% of hourly wage	*plus 7% of hourly wage

Journeyman Lineman or Equipment Operators with Crane License	\$ 26.40 *plus 7% of hourly wage	\$ 27.90 *plus 7% of hourly wage	\$ 29.40 *plus 7% of hourly wage	\$ 30.90 *plus 7% of hourly wage
--	--	--	--	--

\*The 7% is based on the hourly wage paid, straight time or premium time.

**OVERTIME PAY**

See ( B, E, Q, ) on OVERTIME PAGE. \*Note\* Double time for emergency work designated by the Dept of Jurisdiction.  
 NOTE: WAGE CAP - Double the straight time hourly base wage shall be the maximum hourly wage compensation for any hour worked.  
 Contractor is still responsible to pay the hourly benefit amount for each hour worked.

**HOLIDAY**

Paid See ( 5, 6, 8, 13, 25 ) on HOLIDAY PAGE plus Governor of NYS Election Day.  
 Overtime See ( 5, 6, 8, 13, 25 ) on HOLIDAY PAGE plus Governor of NYS Election Day.

NOTE: All paid holidays falling on Saturday shall be observed on the preceding Friday. All paid holidays falling on Sunday shall be observed on the following Monday. Supplements for holidays paid at straight time.

**REGISTERED APPRENTICES**

WAGES per hour: 1000 hour terms at the following percentage of the applicable Journeyman Lineman wage.

1st	2nd	3rd	4th	5th	6th	7th
60%	65%	70%	75%	80%	85%	90%

SUPPLEMENTAL BENEFITS per hour:

07/01/2021	05/02/2022	05/01/2023	05/06/2024
\$25.40	\$ 25.90	\$ 26.40	\$ 26.90
*plus 7% of hourly Wage	*plus 7% of hourly wage	*plus 7% of hourly wage	*plus 7% of hourly wage

\*The 7% is based on the hourly wage paid, straight time or premium time.

6-1249aWest

**Lineman Electrician - Teledata**

**05/01/2022**

**JOB DESCRIPTION** Lineman Electrician - Teledata

**DISTRICT 6**

**ENTIRE COUNTIES**

Albany, Allegany, Broome, Cattaraugus, Cayuga, Chautauqua, Chemung, Chenango, Clinton, Columbia, Cortland, Delaware, Dutchess, Erie, Essex, Franklin, Fulton, Genesee, Greene, Hamilton, Herkimer, Jefferson, Lewis, Livingston, Madison, Monroe, Montgomery, Niagara, Oneida, Onondaga, Ontario, Orange, Orleans, Oswego, Otsego, Putnam, Rensselaer, Rockland, Saratoga, Schenectady, Schoharie, Schuyler, Seneca, St. Lawrence, Steuben, Sullivan, Tioga, Tompkins, Ulster, Warren, Washington, Wayne, Westchester, Wyoming, Yates

**WAGES**

Per hour:

For outside work, stopping at first point of attachment (demarcation).  
 07/01/2021

Cable Splicer	\$ 34.78
Installer, Repairman	\$ 33.01
Teledata Lineman	\$ 33.01
Tech., Equip. Operator	\$ 33.01
Groundman	\$ 17.50

NOTE: EXCLUDES Teledata work within ten (10) feet of High Voltage (600 volts and over) transmission lines. For this work please see LINEMAN.

NOTE: THE FOLLOWING RATES WILL APPLY ON ALL CONTRACTING AGENCY MANDATED MULTIPLE SHIFTS OF AT LEAST FIVE (5) DAYS DURATION WORKED:

1ST SHIFT	REGULAR RATE
2ND SHIFT	REGULAR RATE PLUS 10%
3RD SHIFT	REGULAR RATE PLUS 15%

**SUPPLEMENTAL BENEFITS**

Per hour:

Journeyman	\$ 5.14
	*plus 3% of wage paid

\*The 3% is based on the hourly wage paid, straight time rate or premium rate.

**OVERTIME PAY**

See (B, E, Q) on OVERTIME PAGE

NOTE: WAGE CAP - Double the straight time hourly base wage shall be the maximum hourly wage compensation for any hour worked.

Contractor is still responsible to pay the hourly benefit amount for each hour worked.

**HOLIDAY**

Paid: See (1) on HOLIDAY PAGE

Overtime: See (5, 6, 16) on HOLIDAY PAGE

6-1249LT - Teledata

**Lineman Electrician - Traffic Signal, Lighting** **05/01/2022**

**JOB DESCRIPTION** Lineman Electrician - Traffic Signal, Lighting

**DISTRICT** 6

**ENTIRE COUNTIES**

Westchester

**WAGES**

Lineman/Technician shall perform all overhead aerial work. A Lineman/Technician on the ground will install all electrical panels, connect all grounds, install and connect all electrical conductors which includes, but is not limited to road loop wires; conduit and plastic or other type pipes that carry conductors, flex cables and connectors, and to oversee the encasement or burial of such conduits or pipes.

A Groundman/Groundman Truck Driver shall: Build and set concrete forms, handle steel mesh, set footer cages, transport concrete in a wheelbarrow, hand or machine concrete vibrator, finish concrete footers, mix mortar, grout pole bases, cover and maintain footers while curing in cold weather, operate jack hammer, operate hand pavement breaker, tamper, concrete and other motorized saws, as a drill helper, operate and maintain generators, water pumps, chainsaws, sand blasting, operate mulching and seeding machine, air tools, electric tools, gas tools, load and unload materials, hand shovel and/or broom, prepare and pour mastic and other fillers, assist digger operator equipment operator in ground excavation and restoration, landscape work and painting. Only when assisting a lineman technician, a groundman/truck driver may assist in installing conduit, pipe, cables and equipment.

A flagger's duties shall consist of traffic control only.  
 (Ref #14.01.03)

Per hour:	07/01/2021	05/02/2022	05/01/2023	05/06/2024
Lineman, Technician	\$ 52.56	\$ 53.60	\$ 54.73	\$ 55.95
Crane, Crawler Backhoe	52.56	53.60	54.73	55.95
Certified Welder	55.19	56.28	57.47	58.75
Digging Machine	47.30	48.24	49.26	50.36
Tractor Trailer Driver	44.68	45.56	46.52	47.56
Groundman, Truck Driver	42.05	42.88	43.78	44.76
Equipment Mechanic	42.05	42.88	43.78	44.76
Flagman	31.54	32.16	32.84	33.57

Above rates are applicable for installation, testing, operation, maintenance and repair on all Traffic Control (Signal) and Illumination (Lighting) projects, Traffic Monitoring Systems, and Road Weather Information Systems. Includes digging of holes for poles, anchors, footer foundations for electrical equipment; assembly of all electrical materials or raceway; placing of fish wire; pulling of cables, wires or fiber optic cable through such raceways; splicing of conductors; dismantling of such structures, lines or equipment.

NOTE: THE FOLLOWING RATES WILL APPLY ON ALL CONTRACTING AGENCY MANDATED MULTIPLE SHIFTS OF AT LEAST FIVE (5) DAYS DURATION WORKED BETWEEN THE HOURS LISTED BELOW:

1ST SHIFT	8:00 AM TO 4:30 PM REGULAR RATE
2ND SHIFT	4:30 PM TO 1:00 AM REGULAR RATE PLUS 17.3%
3RD SHIFT	12:30 AM TO 9:00 AM REGULAR RATE PLUS 31.4%

Four (4), ten (10) hour days may be worked at straight time during a week, Monday thru Thursday. Friday may be used as a make-up day. Tuesday thru Friday may be worked with no make-up day.

NOTE - In order to use the '4 Day/10 Hour Work schedule', as your normal schedule, you must submit an 'Employer Registration for Use of 4 Day/10 Hour Work Schedule,' form PW30.1; and there must be a dispensation of hours in place on the project. If the PW30.1 is not submitted you may be liable for overtime payments for work over 8 hours per day.

**SUPPLEMENTAL BENEFITS**

Per hour worked (but also required on non-worked holidays):

\$25.40	\$ 25.90	\$ 26.40	\$ 26.90
*plus 7% of	*plus 7% of	*plus 7% of	*plus 7% of

	hourly Wage	hourly wage	hourly wage	hourly wage
Journeyman Lineman or Equipment Operators with Crane License	\$ 26.40 *plus 7% of hourly wage	\$ 27.90 *plus 7% of hourly wage	\$ 29.40 *plus 7% of hourly wage	\$ 30.90 *plus 7% of hourly wage

\*The 7% is based on the hourly wage paid, straight time or premium time.

**OVERTIME PAY**

See (B, E, Q) on OVERTIME PAGE. \*Note\* Double time for emergency work designated by the Dept. of Jurisdiction.  
 NOTE: WAGE CAP - Double the straight time hourly base wage shall be the maximum hourly wage compensation for any hour worked.  
 Contractor is still responsible to pay the hourly benefit amount for each hour worked.

**HOLIDAY**

Paid: See ( 5, 6, 8, 13, 25 ) on HOLIDAY PAGE and Governor of NYS Election Day.  
 Overtime: See ( 5, 6, 8, 13, 25 ) on HOLIDAY PAGE and Governor of NYS Election Day.

NOTE: All paid holidays falling on Saturday shall be observed on the preceding Friday. All paid holidays falling on Sunday shall be observed on the following Monday. Supplements for holidays paid at straight time.

**REGISTERED APPRENTICES**

WAGES per hour: 1000 hour terms at the following percentage of the applicable Journeyman Lineman wage.

1st	2nd	3rd	4th	5th	6th	7th
60%	65%	70%	75%	80%	85%	90%

SUPPLEMENTAL BENEFITS per hour:

07/01/2021	05/02/2022	05/01/2023	05/06/2024
\$25.40 *plus 7% of hourly Wage	\$ 25.90 *plus 7% of hourly wage	\$ 26.40 *plus 7% of hourly wage	\$ 26.90 *plus 7% of hourly wage

\*The 7% is based on the hourly wage paid, straight time or premium time.

6-1249aWestLT

**Mason - Building** **05/01/2022**

**JOB DESCRIPTION** Mason - Building **DISTRICT 9**

**ENTIRE COUNTIES**  
 Nassau, Rockland, Suffolk, Westchester

**WAGES**

Per hour:	07/01/2021	12/06/2021	06/06/2022
Tile Setters	\$ 61.07	\$ 61.44	Additional \$ 0.72

**SUPPLEMENTAL BENEFITS**

Per Hour:	07/01/2021	12/06/2021
	\$ 24.91* + \$10.01	\$ 25.01* + \$10.02

\* This portion of benefits subject to same premium rate as shown for overtime wages.

**OVERTIME PAY**

See (B, E, Q, V) on OVERTIME PAGE  
 Work beyond 10 hours on Saturday shall be paid at double the hourly wage rate.

**HOLIDAY**

Paid: See (1) on HOLIDAY PAGE  
 Overtime: See (5, 6, 11, 15, 16, 25) on HOLIDAY PAGE

**REGISTERED APPRENTICES**

Wage per hour:

Tile Setters:  
 (750 hour) term at the following wage rate:

Term:	1st	2nd	3rd	4th	5th	6th	7th	8th	9th	10th
	1-750	751-1500	1501-2250	2251-3000	3001-3750	3751-4500	4501-5250	5251-6000	6001-6750	6501-7000

07/01/2021	\$20.84	\$25.66	\$32.68	\$37.50	\$40.99	\$44.30	\$47.82	\$52.63	\$55.35	\$59.34
------------	---------	---------	---------	---------	---------	---------	---------	---------	---------	---------

Supplemental Benefits per hour:

1st	2nd	3rd	4th	5th	6th	7th	8th	9th	10th
\$12.55*	\$12.55*	\$15.16*	\$15.16*	\$16.16*	\$17.66*	\$18.66*	\$18.66*	\$16.66*	\$21.91*
+\$0.66	+\$0.71	+\$0.81	+\$0.85	+\$1.23	+\$1.28	+\$1.63	+\$1.68	+\$5.83	+\$6.32

\* This portion of benefits subject to same premium rate as shown for overtime wages.

9-7/52A

**Mason - Building** **05/01/2022**

**JOB DESCRIPTION** Mason - Building

**DISTRICT** 11

**ENTIRE COUNTIES**

Putnam, Rockland, Westchester

**PARTIAL COUNTIES**

Orange: Only the Township of Tuxedo.

**WAGES**

Per hour:

	07/01/2021	06/01/2022 Additional	06/01/2023 Additional
Bricklayer	\$ 43.35	\$ 2.39	\$ 2.05
Cement Mason	43.35	2.39	2.05
Plasterer/Stone Mason	43.35	2.39	2.05
Pointer/Caulker	43.35	2.39	2.05

Additional \$1.00 per hour for power saw work

Additional \$0.50 per hour for swing scaffold or staging work

SHIFT WORK: When shift work or an irregular work day is mandated or required by state, federal, county, local or other governmental agency contracts, the following premiums apply:

Irregular work day requires 15% premium

Second shift an additional 15% of wage plus benefits to be paid

Third shift an additional 25% of wage plus benefits to be paid

**SUPPLEMENTAL BENEFITS**

Per hour:

Journeyman \$ 36.05.

**OVERTIME PAY**

OVERTIME:

Cement Mason See ( B, E, Q, W ) on OVERTIME PAGE.

All Others See ( B, E, Q ) on OVERTIME PAGE.

**HOLIDAY**

Paid: See (1) on HOLIDAY PAGE

Overtime: See (5, 6, 16, 25) on HOLIDAY PAGE

Whenever any of the above holidays fall on Sunday, they will be observed on Monday. Whenever any of the above holidays fall on Saturday, they will be observed on Friday.

**REGISTERED APPRENTICES**

Wages per hour:

750 hour terms at the following percentage of Journeyman's wage

1st	2nd	3rd	4th	5th	6th	7th	8th
50%	55%	60%	65%	70%	75%	80%	85%

Supplemental Benefits per hour

750 hour terms at the following percentage of journeyman supplements

1st	2nd	3rd	4th	5th	6th	7th	8th
50%	55%	60%	65%	70%	75%	80%	85%

Apprentices indentured before June 1st, 2011 receive full journeyman benefits

**Mason - Building**

**05/01/2022**

**JOB DESCRIPTION** Mason - Building

**DISTRICT** 9

**ENTIRE COUNTIES**

Bronx, Kings, Nassau, New York, Queens, Richmond, Suffolk, Westchester

**WAGES**

Building

	07/01/2021	01/01/2022
Wages per hour:		
Mosaic & Terrazzo Mechanic	\$ 58.46	\$ 59.21
Mosaic & Terrazzo Finisher	\$ 56.86	\$ 57.60

**SUPPLEMENTAL BENEFITS**

Per hour:

Mosaic & Terrazzo Mechanic	\$ 26.11* + \$11.73	\$ 26.21* + \$11.73
Mosaic & Terrazzo Finisher	\$ 26.11* + \$11.71	\$ 26.21* + \$11.72

\*This portion of benefits subject to same premium rate as shown for overtime wages.

**OVERTIME PAY**

See (A, E, Q) on OVERTIME PAGE

07/01/2021-Deduct \$6.80 from hourly wages before calculating overtime.

01/01/2022- Deduct \$7.00 from hourly wages before calculating overtime.

**HOLIDAY**

Paid: See (1) on HOLIDAY PAGE

Overtime: See (5, 6, 8, 11, 15, 16, 25) on HOLIDAY PAGE

Easter Sunday is an observed holiday. Holidays falling on a Saturday will be observed on that Saturday. Holidays falling on a Sunday will be celebrated on the Monday.

**REGISTERED APPRENTICES**

Wages per hour:

(750 Hour) terms at the following wage rate.

	1st	2nd	3rd	4th	5th	6th	7th	8th
07/01/2021	\$ 25.82	\$ 28.40	\$ 31.00	\$ 33.58	\$ 36.16	\$ 38.74	\$ 43.91	\$ 49.08
01/01/2022	\$ 26.09	\$ 28.71	\$ 31.32	\$ 33.94	\$ 36.55	\$ 39.15	\$ 44.38	\$ 49.60

Supplemental benefits per hour:

07/01/2021	\$13.06* +\$9.27	\$14.37* +\$10.19	\$15.67* +\$11.12	\$16.98* +\$12.04	\$18.28* +\$12.97	\$19.59* +\$13.90	\$22.20* +\$15.75	\$24.81* +\$17.60
01/01/2022	\$13.11* +\$9.37	\$14.42* +\$10.30	\$15.73* +\$11.24	\$17.04* +\$12.17	\$18.35* +\$13.11	\$19.66* +\$14.05	\$22.28* +\$15.92	\$24.90* +\$17.79

Apprentices hired after 07/01/2017:

Wages Per hour:

	1st 0- 1500	2nd 1501- 3000	3rd 3001- 3750	4th 3751- 4500	5th 4501- 5250	6th 5251- 6000
07/01/2021	\$ 22.63	\$ 29.10	\$ 31.00	\$ 36.16	\$ 41.32	\$ 46.48
01/01/2022	\$ 22.82	\$ 29.34	\$ 31.32	\$ 36.55	\$ 41.77	\$ 46.99



Supplemental Benefits per hour:

	1st	2nd	3rd	4th	5th	6th
07/01/2021	\$4.59*	\$5.90*	\$15.67*	\$18.28*	\$20.89*	\$23.50*
	+\$6.49	+\$8.34	+\$11.12	+\$12.97	+\$14.83	+\$16.67
01/01/2022	\$4.62*	\$5.94*	\$15.73*	\$18.35*	\$20.97*	\$23.59*
	+\$6.56	+\$8.43	+\$11.24	+\$13.11	+\$14.99	+\$16.85

\*This portion of benefits subject to same premium rate as shown for overtime wages.

9-7/3

**Mason - Building** **05/01/2022**

**JOB DESCRIPTION** Mason - Building **DISTRICT 9**

**ENTIRE COUNTIES**  
 Bronx, Kings, Nassau, New York, Queens, Richmond, Suffolk, Westchester

**WAGES**  
 Per hour: 07/01/2021 01/01/2022

Building-Marble Restoration:  
 Marble, Stone & Terrazzo Polisher, etc \$ 46.16 \$ 46.60

**SUPPLEMENTAL BENEFITS**  
 Per Hour:  
 Journeyworker:  
 Building-Marble Restoration:  
 Marble, Stone & Polisher \$ 29.11 \$ 29.77

**OVERTIME PAY**  
 See (B, \*E, Q, V) on OVERTIME PAGE  
 \*ON SATURDAYS, 8TH HOUR AND SUCCESSIVE HOURS PAID AT DOUBLE HOURLY RATE.

**HOLIDAY**  
 Paid: See (1) on HOLIDAY PAGE  
 Overtime: See (5, 6, 8, 11, 15, 25) on HOLIDAY PAGE  
 1ST TERM APPRENTICE GETS PAID FOR ALL OBSERVED HOLIDAYS.

**REGISTERED APPRENTICES**  
 WAGES per hour:

900 hour term at the following wage:

	1st 1- 900	2nd 901- 1800	3rd 1801- 2700	4th 2701
07/01/2021	\$32.28	\$36.91	\$41.51	\$46.16
01/01/2022	\$32.61	\$37.28	\$41.94	\$46.60

Supplemental Benefits Per Hour:  
 07/01/2021 \$26.47 \$27.34 \$28.29 \$29.11  
 01/01/2022 \$27.07 \$27.97 \$28.87 \$29.77

9-7/24-MP

**Mason - Building** **05/01/2022**

**JOB DESCRIPTION** Mason - Building **DISTRICT 9**

**ENTIRE COUNTIES**  
 Bronx, Dutchess, Kings, Nassau, New York, Orange, Putnam, Queens, Richmond, Rockland, Suffolk, Sullivan, Ulster, Westchester

**WAGES**  
 Wages: 07/01/2021 01/03/2022

Marble Cutters & Setters \$ 61.73 \$ 62.17

**SUPPLEMENTAL BENEFITS**

Per Hour:

Journeyworker \$ 37.76 \$ 38.27

**OVERTIME PAY**

See (B, E, Q, V) on OVERTIME PAGE

**HOLIDAY**

Paid: See (1) on HOLIDAY PAGE

Overtime: See (5, 6, 8, 11, 15, 16, 25) on HOLIDAY PAGE

**REGISTERED APPRENTICES**

Wage Per Hour:

750 hour terms at the following wage.

1st	2nd	3rd	4th	5th	6th	7th	8th	9th	10th
1-750	751-1500	1501-2250	2251-3000	3001-3750	3751-4500	4501-5250	5251-6000	6001-6751	6751-7500
07/01/2021 \$ 24.70	\$ 27.77	\$ 30.87	\$ 33.94	\$ 37.03	\$ 40.11	\$ 43.20	\$ 46.29	\$ 52.46	\$ 58.64
01/03/2022 \$ 24.88	\$ 27.97	\$ 31.08	\$ 34.17	\$ 37.29	\$ 40.39	\$ 43.51	\$ 46.61	\$ 52.82	\$ 59.05

Supplemental Benefits per hour:

1st	2nd	3rd	4th	5th	6th	7th	8th	9th	10th
07/01/2021 \$ 20.01	\$ 21.43	\$ 22.83	\$ 24.25	\$ 25.65	\$ 27.07	\$ 28.47	\$ 29.88	\$ 32.70	\$ 35.51
01/03/2022 \$ 20.55	\$ 22.04	\$ 23.52	\$ 25.01	\$ 26.47	\$ 27.96	\$ 29.42	\$ 30.91	\$ 33.86	\$ 36.81 9-7/4

**Mason - Building** **05/01/2022**

**JOB DESCRIPTION** Mason - Building

**DISTRICT** 9

**ENTIRE COUNTIES**

Nassau, Rockland, Suffolk, Westchester

**WAGES**

Per hour: 07/01/2021 12/06/2021 06/06/2022

Tile Finisher \$ 46.89 \$ 47.18 Additional \$ 0.58

**SUPPLEMENTAL BENEFITS**

Per Hour: \$ 21.91\* + \$9.84 \$ 22.01\* + \$9.84

\*This portion of benefits subject to same premium rate as shown for overtime wages

**OVERTIME PAY**

See (B, E, Q, \*V) on OVERTIME PAGE

Work beyond 10 hours on a Saturday shall be paid at double the hourly wage rate.

**HOLIDAY**

Paid: See (1) on HOLIDAY PAGE

Overtime: See (5, 6, 11, 15, 16, 25) on HOLIDAY PAGE

9-7/88A-tf

**Mason - Building** **05/01/2022**

**JOB DESCRIPTION** Mason - Building

**DISTRICT** 9

**ENTIRE COUNTIES**

Bronx, Kings, Nassau, New York, Queens, Richmond, Suffolk, Westchester

**WAGES**

Per hour: 07/01/2021 01/01/2022

Marble, Stone, etc.  
 Maintenance Finishers: \$ 26.73 \$ 27.01

Note 1: An additional \$2.00 per hour  
 for time spent grinding floor using  
 "60 grit" and below.

Note 2: Flaming equipment operator  
 shall be paid an additional \$25.00 per day.

**SUPPLEMENTAL BENEFITS**

Per Hour:

Marble, Stone, etc  
 Maintenance Finishers: \$ 14.00 \$ 14.40

**OVERTIME PAY**

See (B, \*E, Q, V) on OVERTIME PAGE

\*Double hourly rate after 8 hours on Saturday

**HOLIDAY**

Paid: See (5, 6, 8, 11, 15, 25) on HOLIDAY PAGE

Overtime: See (5, 6, 8, 11, 15, 25) on HOLIDAY PAGE

1st term apprentice gets paid for all observed holidays.

**REGISTERED APPRENTICES**

WAGES per hour:

	07/01/2021	01/01/2022
0-750	\$21.37	\$21.67
751-1500	\$22.09	\$22.38
1501-2250	\$22.81	\$23.10
2251-3000	\$23.52	\$23.80
3001-3750	\$24.61	\$24.87
3751-4500	\$26.04	\$26.29
4501+	\$26.73	\$27.01

Supplemental Benefits:

Per hour:

0-750	\$ 11.24	\$11.52
751-1500	\$ 11.60	\$11.90
1501-2250	\$ 11.97	\$12.29
2251-3000	\$ 12.35	\$12.67
3001-3750	\$ 12.84	\$13.25
3751-4500	\$ 13.63	\$14.01
4501+	\$ 14.00	\$14.40

9-7/24M-MF

**Mason - Building / Heavy&Highway**

**05/01/2022**

**JOB DESCRIPTION** Mason - Building / Heavy&Highway

**DISTRICT** 9

**ENTIRE COUNTIES**

Bronx, Kings, Nassau, New York, Queens, Richmond, Suffolk, Westchester

**WAGES**

Per hour: 07/01/2021 01/03/2022

Marble-Finisher \$ 48.87 \$ 48.97

**SUPPLEMENTAL BENEFITS**

Journeyworker:  
 per hour

Marble- Finisher \$ 35.25 \$ 35.76

**OVERTIME PAY**

See (B, E, Q, V) on OVERTIME PAGE

**HOLIDAY**

Overtime: See (5, 6, 8, 11, 15, 16, 25) on HOLIDAY PAGE

\* Work beyond 8 hours on a Saturday shall be paid at double the rate.

\*\* When an observed holiday falls on a Sunday, it will be observed the next day.

9-7/20-MF

**Mason - Heavy&Highway**

**05/01/2022**

**JOB DESCRIPTION** Mason - Heavy&Highway

**DISTRICT** 11

**ENTIRE COUNTIES**

Putnam, Rockland, Westchester

**PARTIAL COUNTIES**

Orange: Only the Township of Tuxedo.

**WAGES**

Per hour:

	07/01/2021	06/01/2022 Additional	06/01/2023 Additional
Bricklayer	\$ 43.85	\$ 2.39	\$ 2.05
Cement Mason	43.85	2.39	2.05
Marble/Stone Mason	43.85	2.39	2.05
Plasterer	43.85	2.39	2.05
Pointer/Caulker	43.85	2.39	2.05

Additional \$1.00 per hour for power saw work

Additional \$0.50 per hour for swing scaffold or staging work

SHIFT WORK: When shift work or an irregular work day is mandated or required by state, federal, county, local or other governmental contracts, the following rates apply:

Irregular work day requires 15% premium

Second shift an additional 15% of wage plus benefits to be paid

Third shift an additional 25% of wage plus benefits to be paid

**SUPPLEMENTAL BENEFITS**

Per hour:

Journeyman \$ 36.05

**OVERTIME PAY**

Cement Mason See ( B, E, Q, W, X )

All Others See ( B, E, Q, X )

**HOLIDAY**

Paid: See (5, 6, 16, 25) on HOLIDAY PAGE

Overtime: See (5, 6, 16, 25) on HOLIDAY PAGE

Whenever any of the above holidays fall on Sunday, they will be observed on Monday. Whenever any of the above holidays fall on Saturday, they will be observed on Friday.

**REGISTERED APPRENTICES**

Wages per hour:

750 hour terms at the following percentage of Journeyman's wage

1st	2nd	3rd	4th	5th	6th	7th	8th
50%	55%	60%	65%	70%	75%	80%	85%

Supplemental Benefits per hour

750 hour terms at the following percentage of journeyman supplements

1st	2nd	3rd	4th	5th	6th	7th	8th
50%	55%	60%	65%	70%	75%	80%	85%

Apprentices indentured before June 1st, 2011 receive full journeyman benefits

11-5WP-H/H

**Operating Engineer - Building**

**05/01/2022**

**JOB DESCRIPTION** Operating Engineer - Building

**DISTRICT** 9

**ENTIRE COUNTIES**

Bronx, Kings, New York, Putnam, Queens, Richmond, Westchester

**PARTIAL COUNTIES**

Dutchess: that part of Dutchess County lying south of the North City Line of the City of Poughkeepsie.

**WAGES**

NOTE:Construction surveying

Party Chief--One who directs a survey party

Instrument Man--One who runs the instrument and assists Party Chief.

Rodman--One who holds the rod and assists the Survey Crew

Wages:(Per Hour) 07/01/2021

Building Construction:

Party Chief	\$ 76.09
Instrument Man	\$ 60.41
Rodman	\$ 41.11

Steel Erection:

Party Chief	\$ 79.02
Instrument Man	\$ 62.89
Rodman	\$ 44.03

Heavy Construction-NYC counties only:  
(Foundation, Excavation.)

Party Chief	\$ 84.60
Instrument man	\$ 63.79
Rodman	\$ 54.52

**SUPPLEMENTAL BENEFITS**

Per Hour: 07/01/2021

Building Construction \$ 24.40\* +\$ 7.15

Steel Erection \$ 25.00\* +\$ 7.15

Heavy Construction \$ 25.25\* +\$ 7.15

\* This portion subject to same premium as wages

Non-Worked Holiday Supplemental Benefit:

\$ 16.45

**OVERTIME PAY**

See (A, B, E, Q) on OVERTIME PAGE

Code "A" applies to Building Construction and has double the rate after 7 hours on Saturdays.

Code "B" applies to Heavy Construction and Steel Erection and had double the rate after 8 hours on Saturdays.

**HOLIDAY**

Paid: See (5, 6, 9, 11, 15, 16, 25) on HOLIDAY PAGE

Overtime: See (5, 6, 9, 11, 15, 16, 25) on HOLIDAY PAGE

9-15Db

---

**Operating Engineer - Building**

**05/01/2022**

**JOB DESCRIPTION** Operating Engineer - Building

**DISTRICT 8**

**ENTIRE COUNTIES**

Putnam, Westchester

**PARTIAL COUNTIES**

Dutchess: All the counties of Westchester and Putnam and the southern part of Dutchess County defined by the northern boundary line of the City of Poughkeepsie, then due east to Route 115, then north along Route 115 to Bedell Road, then east along Bedell Road to Van Wagner Road, then north along Van Wagner Road to Bower Road, then east along Bower Road to Route 44 and along Route 44 east to Route 343, then along Route 343 east to the northern boundary of Town of Dover Plains and east along the northern boundary of Town of Dover Plains to the border line of the State of Connecticut and bordered on the west by the middle of the Hudson River.

**WAGES**

GROUP I:

Cranes (All Types up to 49 tons), Boom Trucks, Cherry Pickers (All Types), Clamshell Crane, Derrick (Stone and Steel), Dragline, Franki Pile Rig or similar, High Lift (Lull or similar) with crane attachment and winch used for hoisting or lifting, Hydraulic Cranes, Pile Drivers, Potain and similar.

Cranes (All types 50-99 tons), Drill Rig Casa Grande (CAT or similar), Franki Pile Rig or similar, Hydraulic Cranes (All types including Crawler Cranes- No specific boom length).

Cranes (All types 100 tons and over), All Tower Cranes, All Climbing Cranes irrespective of manufacturer and regardless of how the same is rigged, Franki Pile Rig or similar, Conventional Cranes (All types including Crawler Cranes-No specific boom length), Hydraulic Cranes.

GROUP I-A: Barber Green Loader-Euclid Loader, Bulldozer, Carrier-Trailer Horse, Concrete Cleaning Decontamination Machine Operator, Concrete-Portable Hoist, Conway or Similar Mucking Machines, Elevator & Cage, Excavators all types, Front End Loaders, Gradall, Shovel, Backhoe, etc.(Crawler or Truck), Heavy Equipment Robotics Operator/Mechanic, Hoist Engineer-Material, Hoist Portable Mobile Unit, Hoist(Single, Double or Triple Drum), Horizontal Directional Drill Locator, Horizontal Directional Drill Operator and Jersey Spreader, Letourneau or Tournapull(Scrapers over 20 yards Struck), Lift Slab Console, etc., Lull HiLift or Similar, Master Environmental Maintenance Mechanics, Mucking Machines Operator/Mechanic or Similar Type, Overhead Crane, Pavement Breaker(Air Ram), Paver(Concrete), Post Hole Digger, Power House Plant, Road Boring Machine, Road Mix Machine, Ross Carrier and Similar Machines, Rubber tire double end backhoes and similar machines, Scoopmobile Tractor-Shovel Over 1.5 yards, Shovel (Tunnels), Spreader (Asphalt) Telephie(Cableway), Tractor Type Demolition Equipment, Trenching Machines-Vermeer Concrete Saw Trencher and Similar, Ultra High Pressure Waterjet Cutting Tool System, Vacuum Blasting Machine operator/mechanic, Winch Truck A Frame.

GROUP I-B: Compressor (Steel Erection), Mechanic (Outside All Types), Negative Air Machine (Asbestos Removal), Push Button (Buzz Box) Elevator.

GROUP II: Compactor Self-Propelled, Concrete Pump, Crane Operator in Training (Over 100 Tons), Grader, Machines Pulling Sheep's Foot Roller, Roller (4 ton and over), Scrapers (20 yards Struck and Under), Vibratory Rollers, Welder.

GROUP III-A: Asphalt Plant, Concrete Mixing Plants, Forklift (All power sources), Joy Drill or similar, Tractor Drilling Machine, Loader (1 1/2 yards and under), Portable Asphalt Plant, Portable Batch Plant, Portable Crusher, Skid Steer (Bobcat or similar), Stone Crusher, Well Drilling Machine, Well Point System.

GROUP III-B: Compressor Over 125 cu.Feet, Conveyor Belt Machine regardless of size, Compressor Plant, Ladder Hoist, Stud Machine.

GROUP IV-A: Batch Plant, Concrete Breaker, Concrete Spreader, Curb Cutter Machine, Finishing Machine-Concrete, Fine Grading Machine, Hepa Vac Clean Air Machine, Material Hopper(sand, stone, cement), Mulching Grass Spreader, Pump Gypsum etc, Pump-Plaster-GROUT-Fireproofing. Roller(Under 4 Ton), Spreading and Fine Grading Machine, Steel Cutting Machine, Siphon Pump, Tar Joint Machine, Television Cameras for Water, Sewer, Gas etc. Turbo Jet Burner or Similar Equipment, Vibrator (1 to 5).

GROUP IV-B: Compressor (all types), Heater (All Types), Fire Watchman, Lighting Unit (Portable & Generator) Pump, Pump Station(Water, Sewer, Portable, Temporary), Welding Machine (Steel Erection & Excavation).

GROUP V: Mechanics Helper, Motorized Roller (walk behind), Stock Attendant, Welder's Helper, Maintenance Engineer Crane(75 ton and over).

Group VI-A: Welder Certified

GROUP VI-B: Utility Man, Warehouse Man.

WAGES: (per hour)

	07/01/2021	3/7/2022	3/6/2023
GROUP I			
Cranes- up to 49 tons	\$ 63.86	\$ 65.03	\$ 66.23
Cranes- 50 tons to 99 tons	66.07	67.28	68.53
Cranes- 100 tons and over	75.37	76.77	78.21
GROUP I-A	55.96	56.97	58.01
GROUP I-B	51.60	52.52	53.48
GROUP II	54.00	54.98	55.70
GROUP III-A	52.04	52.97	53.94
GROUP III-B	49.56	50.44	51.35
GROUP IV-A	51.52	52.44	53.40
GROUP IV-B	43.62	44.38	45.17
GROUP V	47.00	47.83	48.69
Group VI-A	54.94	55.93	56.96
GROUP VI-B			
Utility Man	44.61	45.39	46.21
Warehouse Man	46.74	47.57	48.42

An additional 20% to wage when required to wear protective equipment on hazardous/toxic waste projects.  
 Engineers operating cranes with booms 100 feet but less than 149 feet in length will be paid an additional \$2.00 per hour.  
 Engineers operating cranes with booms 149 feet or over in length will be paid an additional \$3.00 per hour.  
 Loader operators over 5 cubic yard capacity additional .50 per hour.  
 Shovel operators over 4 cubic yard capacity additional \$1.00 per hour.

**SUPPLEMENTAL BENEFITS**

Per hour:

	07/01/2021	03/07/2022	03/06/2023
Journeyworker	\$ 29.17	\$ 29.87	\$ 30.57

**OVERTIME PAY**

See (B, E, Q, V) on OVERTIME PAGE

**HOLIDAY**

Paid: See (5, 6, 8, 15, 25, 26) on HOLIDAY PAGE  
 Overtime: See (5, 6, 8, 15, 25, 26) on HOLIDAY PAGE

8-137B

**Operating Engineer - Heavy&Highway**

**05/01/2022**

**JOB DESCRIPTION** Operating Engineer - Heavy&Highway

**DISTRICT 8**

**ENTIRE COUNTIES**

Putnam, Westchester

**PARTIAL COUNTIES**

Dutchess: All the counties of Westchester and Putnam and the southern part of Dutchess County defined by the northern boundary line of the City of Poughkeepsie, then due east to Route 115, then north along Route 115 to Bedell Road, then east along Bedell Road to Van Wagner Road, then north along Van Wagner Road to Bower Road, then east along Bower Road to Route 44 and along Route 44 east to Route 343, then along Route 343 east to the northern boundary of Town of Dover Plains and east along the northern boundary of Town of Dover Plains to the border line of the State of Connecticut and bordered on the west by the middle of the Hudson River.

**WAGES**

GROUP I: Boom Truck, Cherry Picker, Clamshell, Crane, (Crawler, Truck),  
 Dragline, Drill Rig (Casa Grande, Cat, or Similar), Floating Crane (Crane on Barges) under 100 tons, Gin Pole, Hoist Engineer-Concrete (Crane-Derrick-Mine Hoist), Knuckle Boom Crane, Rough Terrain Crane.

GROUP I-A: Auger (Truck or Truck Mounted), Boat Captain, Bulldozer-All Sizes, Central Mix Plant Operator, Chipper (all types), Close Circuit T.V., Combination Loader/Backhoe, Compactor with Blade, Concrete Finishing Machine, Gradall, Grader (Motor Grader), Elevator & Cage (Materials or Passenger), Excavator (and all attachments), Front End Loaders (1 1/2 yards and over), High Lift Lull and similar, Hoist (Single, Double, Triple Drum), Hoist Portable Mobile Unit, Hoist Engineer (Material), Jack and Bore Machine, Log Skidders, Mill Machines, Mucking Machines, Overhead Crane, Paver (concrete), Post Pounder (of any type), Push Cats, Road Reclaimer, Robot Hammer (Brokk or similar), Robotic Equipment (Scope of Engineer Schedule), Ross Carrier and similar, Scrapers (20 yard struck and over), Side Boom, Slip Form Machine, Spreader (Asphalt), Trenching Machines (Telephies-Vermeer Concrete Saw), Tractor Type Demolition Equipment, Vacuum Truck. Vibratory Roller(Riding) or Roller used in mainline paving operations.

GROUP I-B: Asphalt Mobile Conveyor/Transfer Machine, Road Paver (Asphalt).

GROUP II-A: Ballast Regulators, Compactor Self Propelled, Fusion Machine, Rail Anchor Machines, Roller (4 ton and over), Scrapers (20 yard struck and under).

GROUP II-B: Mechanic (Outside) All Types, Shop Mechanic.

GROUP III: Air Tractor Drill, Asphalt Plant, Batch Plant, Boiler (High Pressure), Concrete Breaker (Track or Rubber Tire), Concrete Pump, Concrete Spreader, Excavator Drill, Farm Tractor, Forklift (all types), Gas Tapping (Live), Hydroseeder, Loader (1 1/2 yards and under), Locomotive (all sizes), Machine Pulling Sheeps Foot Roller, Portable Asphalt Plant, Portable Batch Plant, Portable Crusher (Apprentice), Powerhouse Plant, Roller (under 4 ton), Sheer Excavator, Skid Steer/Bobcat, Stone Crusher, Sweeper (with seat), Well Drilling Machine.

GROUP IV: Service Person (Grease Truck), Deckhand.

GROUP IV-B: Conveyor Belt Machine (Truck Mounted), Heater (all types), Lighting Unit (Portable), Maintenance Engineer (For Crane Only), Mechanics Helper, Pump (Fireproofing), Pumps-Pump Station/Water/Sewer/Gypsum/Plaster, etc., Pump Truck (Sewer Jet or Similar), Welders Helper, Welding Machine (Steel Erection), Well Point System.

GROUP V: All Tower Cranes-All Climbing Cranes and all cranes of 100-ton capacity or greater (3900 Manitowac or similar) irrespective of manufacturer and regardless of how the same is rigged, Hoist Engineer (Steel), Engineer-Pile Driver, Jersey Spreader, Pavement Breaker/Post Hole Digger.

WAGES: Per hour:	07/01/2021	03/07/2022	03/06/2023
Group I	\$ 64.63	\$ 65.97	\$ 67.27
Group I-A	57.02	58.16	59.26

Group I-B	60.06	61.28	62.46
Group II-A	54.61	55.70	56.74
Group II-B	56.31	57.44	58.52
Group III	53.66	54.72	55.74
Group IV	48.80	49.74	50.63
Group IV-B	41.94	42.71	43.43
Group V			
Engineer All Tower, Climbing and Cranes of 100 Tons	73.18	74.73	76.24
Hoist Engineer(Steel)	66.29	67.67	69.01
Engineer(Pile Driver)	70.67	72.16	73.61
Jersey Spreader,Pavement Breaker (Air Ram)Post Hole Digger	55.87	56.99	58.06

**SHIFT DIFFERENTIAL:**

A 15% premium on all hours paid, including overtime hours for 2nd, 3rd shifts  
 on all government mandated off-shift work

Engineers operating cranes with booms 100 feet but less than 149 feet in length will be paid an additional \$2.00 per hour over the rate listed in the Wage Schedule. Engineers operating cranes with booms 149 feet or over in length will be paid an additional \$3.00 per hour over the rate listed in the Wage Schedule. Loader and Excavator Operators: over 5 cubic yards capacity \$0.50 per hour over the rate listed in the Wage Schedule. Shovel Operators: over 4 cubic yards capacity \$1.00 per hour over the rate listed in the Wage Schedule.

Four (4), ten (10) hour days may be worked at straight time during a week, Monday thru Thursday; Friday may be used as a make-up day.

NOTE - In order to use the 4 Day/10 Hour Work schedule Registration for Use of 4 Day/10 Hour Work Schedule,form PW30.1; and there must be a dispensation of hours in place on the project. If the PW30.1 is not submitted you may be liable for overtime payments for work over 8 hours per day.

**SUPPLEMENTAL BENEFITS**

Per hour:

Journeyworker:	07/01/2021	03/07/2022	03/06/2023
	\$ 31.60 up to 40 Hours	\$ 32.60 up to 40 hours	\$ 33.75 up to 40 hours
	After 40 hours \$ 22.40* PLUS \$ 1.20 on all hours worked	After 40 hours \$ 23.40* PLUS \$ 1.20 on all hours worked	After 40 hours \$ 24.50* PLUS \$ 1.25 on all hours worked

\*This amount is subject to premium

**OVERTIME PAY**

See (B, E, E2, P, \*R, \*\*U) on OVERTIME PAGE

**HOLIDAY**

Paid:..... See ( 5, 6, 8, 15, 25, 26 ) on HOLIDAY PAGE

Overtime..... See ( 5, 6, 8, 15, 25, 26 ) on OVERTIME PAGE

\* For Holiday codes 8,15,25,26 code R applies

\*\* For Holiday Codes 5 & 6 code U applies

Note: If employees are required to work on Easter Sunday they shall be paid at the rate of triple time.

**REGISTERED APPRENTICES**

(1)year terms at the following rate.

	07/01/2021	03/07/2022	03/06/2023
1st term	\$ 28.51	\$ 29.08	\$ 29.63
2nd term	34.21	34.90	35.56
3rd term	39.91	40.71	41.48
4th term	45.61	46.53	47.41
Supplemental Benefits per hour:			
	23.60	24.55	25.70

8-137HH



**JOB DESCRIPTION** Operating Engineer - Heavy&Highway

**DISTRICT** 9

**ENTIRE COUNTIES**

Putnam, Westchester

**PARTIAL COUNTIES**

Dutchess: South of the North city line of Poughkeepsie

**WAGES**

Party Chief - One who directs a survey party

Instrument Man - One who runs the instrument and assists Party Chief

Rodman - One who holds the rod and in general, assists the Survey Crew

Catorgories cover GPS & Underground Surveying

Per Hour: 07/01/2021

Party Chief \$ 81.72

Instrument Man 61.43

Rodman 52.40

**SUPPLEMENTAL BENEFITS**

Per Hour: 07/01/2021

All Catorgories  
Straight Time: \$ 25.25\* plus \$7.15

Premium:  
Time & 1/2 \$ 37.88\* plus \$7.15

Double Time \$ 50.50\* plus \$7.15

Non-Worked Holiday Supplemental Benefits:  
\$ 16.45

**OVERTIME PAY**

See (B, \*E, Q) on OVERTIME PAGE

\* Doubletime paid on all hours in excess of 8 hours on Saturday

**HOLIDAY**

Paid: See (5, 6, 7, 11, 12) on HOLIDAY PAGE

Overtime: See (5, 6, 7, 11, 12) on HOLIDAY PAGE

9-15Dh

**Operating Engineer - Heavy&Highway - Tunnel**

**05/01/2022**

**JOB DESCRIPTION** Operating Engineer - Heavy&Highway - Tunnel

**DISTRICT** 8

**ENTIRE COUNTIES**

Putnam, Westchester

**PARTIAL COUNTIES**

Dutchess: All the counties of Westchester and Putnam and the southern part of Dutchess County defined by the northern boundary line of the City of Poughkeepsie, then due east to Route 115, then north along Route 115 to Bedell Road, then east along Bedell Road to Van Wagner Road, then north along Van Wagner Road to Bower Road, then east along Bower Road to Route 44 and along Route 44 east to Route 343, then along Route 343 east to the northern boundary of Town of Dover Plains and east along the northern boundary of Town of Dover Plains to the border line of the State of Connecticut and bordered on the west by the middle of the Hudson River.

**WAGES**

GROUP I: Boom Truck, Cherry Picker, Clamshell, Crane(Crawler,Truck), Dragline, Drill Rig Casa Grande(Cat or Similar), Floating Crane(Crane on Barge-Under 100 Tons), Hoist Engineer(Concrete/Crane-Derrick-Mine Hoist), Knuckle Boom Crane, Rough Terrain Crane.

GROUP I-A: Auger(Truck or Truck Mounted), Boat Captain, Bull Dozer-all sizes, Central Mix Plant Operator, Chipper-all types, Close Circuit T.V., Combination Loader/Backhoe, Compactor with Blade, Concrete Finishing Machine, Gradall, Grader(Motor Grader), Elevator & Cage(Materials or Passengers), Excavator(and all attachments), Front End Loaders(1 1/2 yards and over), High Lift Lull, Hoist(Single, Double, Triple Drum), Hoist Portable Mobile Unit, Hoist Engineer(Material), Jack and Bore Machine, Log Skidder, Milling Machine, Moveable Concrete Barrier Transfer & Transport Vehicle, Mucking Machines. Overhead Crane, Paver(Concrete), Post Pounder of any type, Push Cats, Road Reclaimer, Robot Hammer(Brokk or similar), Robotic Equipment(Scope of Engineer Schedule), Ross Carrier and similar machines, Scrapers(20 yards struck and over), Side Boom, Slip Form Machine, Spreader(Asphalt), Trenching Machines, Telephies-Vermeer Concrete Saw, Tractor type demolition equipment, Vacuum Truck, Vibratory Roller (Riding) used in mainline paving operations.

GROUP I-B: Asphalt Mobile Conveyor/Transfer Machine, Road Paver(Asphalt).

GROUP II-A: Ballast Regulators, Compactor(Self-propelled), Fusion Machine, Rail Anchor Machines, Roller(4 ton and over), Scrapers(20 yard struck and under).

GROUP II-B: Mechanic(outside)all types, Shop Mechanic.

GROUP III: Air Tractor Drill, Asphalt Plant, Batch Plant, Boiler(High Pressure), Concrete Breaker(Track or Rubber Tire), Concrete Pump, Concrete Spreader, Excavator Drill, Farm Tractor, Forklift(all types of power), Gas Tapping(Live), Hydroseeder, Loader(1 1/2 yards and under), Locomotive(all sizes), Machine Pulling Sheeps Foot Roller, Portable Asphalt Plant, Portable Batch Plant, Portable Crusher(Apprentice), Powerhouse Plant, Roller(under 4 ton), Sheer Excavator, Skidsteer/Bobcat, Stone Crusher, Sweeper(with seat), Well Drilling Machine.

GROUP IV-A: Service Person(Grease Truck), Deckhand.

GROUP IV-B: Conveyor Belt Machine(Truck Mounted), Heater(all types), Lighting Unit(Portable), Maintenance Engineer(for Crane only), Mechanics Helper, Pump(Fireproofing), Pumps-Pump Station/Water/Sewer/Gypsum/Plaster, etc., Pump Truck(Sewer Jet or similar), Welding Machine(Steel Erection), Welders Helper.

GROUP V-A: Engineer(all Tower Cranes, all Climbing Cranes & all Cranes of 100 ton capacity or greater),Hoist Engineer(Steel-Sub Structure), Engineer-Pile Driver, Jersey-Spreader, Pavement breaker, Post Hole Digger

WAGES: (per hour)

	07/01/2021	03/07/2022	03/06/2023
GROUP I	\$ 64.63	\$ 65.97	\$ 67.27
GROUP I-A	57.02	58.16	59.21
GROUP I-B	60.06	61.28	62.46
GROUP II-A	54.61	55.70	56.74
GROUP II-B	56.31	57.44	58.52
GROUP III	53.66	54.72	55.74
GROUP IV-A	48.80	49.74	50.63
GROUP IV-B	41.94	42.71	43.43
GROUP V-A			
Engineer-Cranes	73.18	74.73	76.24
Engineer-Pile Driver	70.67	72.16	73.61
Hoist Engineer	66.29	67.67	69.01
Jersey Spreader/Post Hole Digger	55.87	56.99	58.06

**SHIFT DIFFERENTIAL:**

A 15% premium on all hours paid, including overtime hours for 2nd, 3rd shifts on all government mandated off-shift work

An additional 20% to wage when required to wear protective equipment on hazardous/toxic waste projects. Operators required to use two buckets pouring concrete on other than road pavement shall receive \$0.50 per hour over scale. Engineers operating cranes with booms 100 feet but less than 149 feet in length will be paid an additional \$2.00 per hour. Engineers operating cranes with booms 149 feet or over in length will be paid an additional \$3.00 per hour. Operators of shovels with a capacity over (4) cubic yards shall be paid an additional \$1.00 per hour. Operators of loaders with a capacity over (5) cubic yards shall be paid an additional \$0.50 per hour.

**SUPPLEMENTAL BENEFITS**

Per hour:

Journeyworker:

	07/01/2021	03/07/2022	03/06/2023
	\$ 23.60	\$ 24.55	\$ 25.70
	+ \$8.00	+ \$8.00	+ \$8.00
	(Limited to first 40 hours)	(Limited to first 40 hours)	(Limited to first 40 hours)

**OVERTIME PAY**

See (D, O, \*U, V) on OVERTIME PAGE

**HOLIDAY**

Paid: See (5, 6, 8, 15, 25, 26) on HOLIDAY PAGE

Overtime: See (5, 6, 8, 15, 25, 26) on HOLIDAY PAGE

\* Note: For Holiday codes 5 & 6, code U applies. For Holiday codes 8, 15, 25, 26, code R applies.

Note: If employees are required to work on Easter Sunday, they shall be paid at the rate of triple time.

**REGISTERED APPRENTICES**

(1)year terms at the following rates:

	07/01/2021	03/07/2022	03/06/2023
1st term	\$ 28.51	\$ 29.08	\$ 29.63
2nd term	34.21	34.90	35.56
3rd term	39.91	40.71	41.48
4th term	45.61	46.53	47.41

Supplemental Benefits per hour:

All terms	\$ 23.60	\$ 24.55	\$ 25.70
-----------	----------	----------	----------

8-137Tun

**Operating Engineer - Marine Dredging**

**05/01/2022**

**JOB DESCRIPTION** Operating Engineer - Marine Dredging

**DISTRICT 4**

**ENTIRE COUNTIES**

Albany, Bronx, Cayuga, Clinton, Columbia, Dutchess, Essex, Franklin, Greene, Jefferson, Kings, Monroe, Nassau, New York, Orange, Oswego, Putnam, Queens, Rensselaer, Richmond, Rockland, St. Lawrence, Suffolk, Ulster, Washington, Wayne, Westchester

**WAGES**

These wages do not apply to Operating Engineers on land based construction projects. For those projects, please see the Operating Engineer Heavy/Highway Rates. The wage rates below for all equipment and operators are only for marine dredging work in navigable waters found in the counties listed above.

Per Hour:	07/01/2021	10/01/2021
CLASS A1 Deck Captain, Leverman Mechanical Dredge Operator Licensed Tug Operator 1000HP or more.	\$ 41.42	\$ 41.42
CLASS A2 Crane Operator (360 swing)	36.91	36.91
CLASS B Dozer, Front Loader Operator on Land	To conform to Operating Engineer Prevailing Wage in locality where work is being performed including benefits.	
CLASS B1 Derrick Operator (180 swing) Spider/Spill Barge Operator Operator II, Fill Placer, Engineer, Chief Mate, Electrician, Chief Welder, Maintenance Engineer Licensed Boat, Crew Boat Operator	35.82	35.82
CLASS B2 Certified Welder	33.72	33.72
CLASS C1 Drag Barge Operator, Steward, Mate, Assistant Fill Placer	32.80	32.80
CLASS C2 Boat Operator	30.89	31.74
CLASS D Shoreman, Deckhand, Oiler, Rodman, Scowman, Cook, Messman, Porter/Janitor	25.66	26.37

**SUPPLEMENTAL BENEFITS**

Per Hour:

THE FOLLOWING SUPPLEMENTAL BENEFITS APPLY TO ALL CATEGORIES

All Classes A & B	07/01/2021 \$11.98 plus 8% of straight time	10/01/2021 \$11.98 plus 8% of straight time
-------------------	---	---

	wage, Overtime hours add \$ 0.63	wage, Overtime hours add \$ 0.63
All Class C	\$11.68 plus 8% of straight time wage, Overtime hours add \$ 0.48	11.68 plus 8% of straight time wage, Overtime hours add \$ 0.48
All Class D	\$11.38 plus 8% of straight time wage, Overtime hours add \$ 0.33	11.38 plus 8% of straight time wage, Overtime hours add \$ 0.33

**OVERTIME PAY**

See (B2, F, R) on OVERTIME PAGE

**HOLIDAY**

Paid: See (1) on HOLIDAY PAGE  
 Overtime: See (5, 6, 8, 15, 26) on HOLIDAY PAGE

4-25a-MarDredge

**Operating Engineer - Survey Crew - Consulting Engineer** **05/01/2022**

**JOB DESCRIPTION** Operating Engineer - Survey Crew - Consulting Engineer **DISTRICT 9**

**ENTIRE COUNTIES**  
 Bronx, Kings, Nassau, New York, Putnam, Queens, Richmond, Suffolk, Westchester

**PARTIAL COUNTIES**  
 Dutchess: That part in Dutchess County lying South of the North City line of Poughkeepsie.

**WAGES**  
 Feasibility and preliminary design surveying, any line and grade surveying for inspection or supervision of construction.

Per hour: 07/01/2021  
 Survey Classifications

Party Chief	\$ 45.83
Instrument Man	38.17
Rodman	33.34

**SUPPLEMENTAL BENEFITS**

Per Hour:  
 All Crew Members: \$ 20.60

**OVERTIME PAY**

OVERTIME:.... See ( B, E\*, Q, V ) ON OVERTIME PAGE.  
 \*Doubletime paid on the 9th hour on Saturday.

**HOLIDAY**

Paid: See (5, 6, 7, 11, 16) on HOLIDAY PAGE  
 Overtime: See (5, 6, 7, 11, 16) on HOLIDAY PAGE

9-15dconsult

**Painter** **05/01/2022**

**JOB DESCRIPTION** Painter **DISTRICT 8**

**ENTIRE COUNTIES**  
 Bronx, Kings, Nassau, New York, Putnam, Queens, Richmond, Suffolk, Westchester

**WAGES**

Per hour: 07/01/2021

Brush	\$ 50.30*
Abatement/Removal of lead based or lead containing paint on materials to be repainted.	50.30*
Spray & Scaffold	\$ 53.30*
Fire Escape	53.30*

Decorator	53.30*
Paperhanger/Wall Coverer	52.93*

\*Subtract \$ 0.10 to calculate premium rate.

**SUPPLEMENTAL BENEFITS**

Per hour: 07/01/2021

Paperhanger	\$ 31.83
All others	29.81
Premium	33.40**

\*\*Applies only to "All others" category, not paperhanger journeyworker.

**OVERTIME PAY**

See (A, H) on OVERTIME PAGE

**HOLIDAY**

Paid: See (1) on HOLIDAY PAGE  
 Overtime: See (5, 6, 16, 25) on HOLIDAY PAGE

**REGISTERED APPRENTICES**

One ( 1 ) year terms at the following wage rate.

Per hour:	07/01/2021
Appr 1st term...	\$ 19.56*
Appr 2nd term...	25.12*
Appr 3rd term...	30.42*
Appr 4th term...	40.65*

\*Subtract \$ 0.10 to calculate premium rate.

Supplemental benefits:

Per Hour:	07/01/2021
Appr 1st term...	\$ 14.72
Appr 2nd term...	18.23
Appr 3rd term...	21.06
Appr 4th term...	26.67

8-NYDC9-B/S

**Painter**

**05/01/2022**

**JOB DESCRIPTION** Painter

**DISTRICT 8**

**ENTIRE COUNTIES**

Putnam, Suffolk, Westchester

**PARTIAL COUNTIES**

Nassau: All of Nassau except the areas described below: Atlantic Beach, Ceaderhurst, East Rockaway, Gibson, Hewlett, Hewlett Bay, Hewlett Neck, Hewlett Park, Inwood, Lawrence, Lido Beach, Long Beach, parts of Lynbrook, parts of Oceanside, parts of Valley Stream, and Woodmere. Starting on the South side of Sunrise Hwy in Valley Stream running east to Windsor and Rockaway Ave., Rockville Centre is the boundary line up to Lawson Blvd. turn right going west all the above territory. Starting at Union Turnpike and Lakeville Rd. going north to Northern Blvd. the west side of Lakeville road to Northern blvd. At Northern blvd. going east the district north of Northern blvd. to Port Washington Blvd. West of Port Washington blvd. to St. Francis Hospital then north of first traffic light to Port Washington and Sands Point, Manor HAVen, Harbour Acres.

**WAGES**

Per hour:	07/01/2021
Drywall Taper	\$ 50.30*

\*Subtract \$ 0.10 to calculate premium rate.

**SUPPLEMENTAL BENEFITS**

Per hour:	07/01/2021
Journeyman	\$ 29.81

**OVERTIME PAY**

See (A, H) on OVERTIME PAGE

**HOLIDAY**

Paid: See (1) on HOLIDAY PAGE  
 Overtime: See (5, 6, 16, 25) on HOLIDAY PAGE

**REGISTERED APPRENTICES**

Wages - Per Hour:	07/01/2021
-------------------	------------

1500 hour terms at the following wage rate:

1st term	\$ 19.56*
2nd term	25.12*
3rd term	30.42*
4th term	40.65*

\*Subtract \$ 0.10 to calculate premium rate.

Supplemental Benefits - Per hour:  
One year term (1500 hours) at the following dollar amount.

1st year	\$ 14.72
2nd year	18.23
3rd year	21.06
4th year	26.67

8-NYDCT9-DWT

---

**Painter - Bridge & Structural Steel**

**05/01/2022**

**JOB DESCRIPTION** Painter - Bridge & Structural Steel

**DISTRICT 8**

**ENTIRE COUNTIES**

Albany, Bronx, Clinton, Columbia, Dutchess, Essex, Franklin, Fulton, Greene, Hamilton, Kings, Montgomery, Nassau, New York, Orange, Putnam, Queens, Rensselaer, Richmond, Rockland, Saratoga, Schenectady, Schoharie, Suffolk, Sullivan, Ulster, Warren, Washington, Westchester

**WAGES**

Per Hour:

STEEL:

Bridge Painting:	07/01/2021	10/01/2021
	\$ 51.50	\$ 53.00
	+ 8.63*	+ 9.63*

ADDITIONAL \$6.00 per hour for POWER TOOL/SPRAY, whether straight time or overtime.

NOTE: All premium wages are to be calculated on base rate per hour only.

\* For the period of May 1st to November 15th, this amount is payable up to 40 hours. For the period of Nov 16th to April 30th, this amount is payable up to 50 hours. EXCEPTION: First and last week of employment, and for the weeks of Memorial Day, Independence Day and Labor Day, where the amount is paid for the actual number of hours worked (no cap).

NOTE: Generally, for Bridge Painting Contracts, ALL WORKERS on and off the bridge (including Flagmen) are to be paid Painter's Rate; the contract must be ONLY for Bridge Painting.

**SHIFT WORK:**

When directly specified in public agency or authority contract documents for an employer to work a second shift and works the second shift with employees other than from the first shift, all employees who work the second shift will be paid 10% of the base wage shift differential in lieu of overtime for the first eight (8) hours worked after which the employees shall be paid at time and one half of the regular wage rate. When a single irregular work shift is mandated in the job specifications or by the contracting agency, wages shall be paid at time and one half for single shifts between the hours of 3pm-11pm or 11pm-7am.

**SUPPLEMENTAL BENEFITS**

Per Hour:

Journeyworker:	07/01/2021	10/01/2021
	\$ 10.90	\$ 10.90
	+ 30.00*	+ 30.60*

\* For the period of May 1st to November 15th, this amount is payable up to 40 hours. For the period of Nov 16th to April 30th, this amount is payable up to 50 hours. EXCEPTION: First and last week of employment, and for the weeks of Memorial Day, Independence Day and Labor Day, where the amount is paid for the actual number of hours worked (no cap).

**OVERTIME PAY**

See (B, F, R) on OVERTIME PAGE

**HOLIDAY**

Paid: See (1) on HOLIDAY PAGE  
Overtime: See (4, 6) on HOLIDAY PAGE

**REGISTERED APPRENTICES**

Wage - Per hour:

Apprentices: (1) year terms

	07/01/2021	10/01/2021
1st year	\$ 20.60 + 3.45*	\$ 21.20 + 3.86*
2nd year	\$ 30.90 + 5.18*	\$ 31.80 + 5.78*
3rd year	\$ 41.20 + 6.90*	\$ 42.40 + 7.70*

Supplemental Benefits - Per hour:

1st year	\$ .25 + 12.00*	\$ .25 + 12.24*
2nd year	\$ 10.90 + 18.00*	\$ 10.90 + 18.36*
3rd year	\$ 10.20 + 24.00*	\$ 10.90 + 24.48*

NOTE: All premium wages are to be calculated on base rate per hour only.

8-DC-9/806/155-BrSS

**Painter - Line Striping**

**05/01/2022**

**JOB DESCRIPTION** Painter - Line Striping

**DISTRICT 8**

**ENTIRE COUNTIES**

Albany, Bronx, Clinton, Columbia, Dutchess, Essex, Franklin, Fulton, Greene, Hamilton, Kings, Montgomery, Nassau, New York, Orange, Putnam, Queens, Rensselaer, Richmond, Rockland, Saratoga, Schenectady, Schoharie, Suffolk, Sullivan, Ulster, Warren, Washington, Westchester

**WAGES**

Per hour:

	07/01/2021	07/01/2022
Painter (Striping-Highway):		
Striping-Machine Operator*	\$ 30.32	\$ 31.53
Linerman Thermoplastic	36.93	38.34

Note: \* Includes but is not limited to: Positioning of cones and directing of traffic using hand held devices. Excludes the Driver/Operator of equipment used in the maintenance and protection of traffic safety.

Four (4), ten (10) hour days may be worked at straight time during a week, Monday thru Thursday. Friday may be used as a make-up day.

NOTE - In order to use the '4 Day/10 Hour Work Schedule,' as your normal schedule, you must submit an 'Employer Registration for Use of 4 Day/10 Hour Work Schedule,' form PW30.1; and there must be a dispensation of hours in place on the project. If the PW30.1 is not submitted you may be liable for overtime payments for work over 8 hours per day.

**SUPPLEMENTAL BENEFITS**

Per hour paid:	07/01/2021	07/01/2022
Journeyworker:		
Striping Machine Operator:	\$ 10.03	\$ 10.03
Linerman Thermoplastic:	10.03	10.03

**OVERTIME PAY**

See (B, B2, E2, F, S) on OVERTIME PAGE

**HOLIDAY**

Paid: See (5, 20) on HOLIDAY PAGE  
 Overtime: See (5, 20) on HOLIDAY PAGE

**REGISTERED APPRENTICES**

One (1) year terms at the following wage rates:

	07/01/2021	12/31/2021	07/01/2022
1st Term*:	\$ 15.00	\$ 15.00	\$ 15.00
1st Term**:	14.00	15.00	15.00
1st Term***:	12.50	13.20	13.20
2nd Term:	18.19	18.19	18.92
3rd Term:	24.26	24.26	25.22

\*Bronx, Kings, New York, Queens, Richmond, and Suffolk counties  
 \*\*Nassau and Westchester counties  
 \*\*\*All other counties

Supplemental Benefits per hour:

1st term:	\$ 9.16	\$ 9.16	\$ 9.16
2nd Term:	9.16	9.16	10.03
3rd Term:	9.16	9.16	10.03

8-1456-LS

**Painter - Metal Polisher**

**05/01/2022**

**JOB DESCRIPTION** Painter - Metal Polisher

**DISTRICT 8**

**ENTIRE COUNTIES**

Albany, Allegany, Bronx, Broome, Cattaraugus, Cayuga, Chautauqua, Chemung, Chenango, Clinton, Columbia, Cortland, Delaware, Dutchess, Erie, Essex, Franklin, Fulton, Genesee, Greene, Hamilton, Herkimer, Jefferson, Kings, Lewis, Livingston, Madison, Monroe, Montgomery, Nassau, New York, Niagara, Oneida, Onondaga, Ontario, Orange, Orleans, Oswego, Otsego, Putnam, Queens, Rensselaer, Richmond, Rockland, Saratoga, Schenectady, Schoharie, Schuyler, Seneca, St. Lawrence, Steuben, Suffolk, Sullivan, Tioga, Tompkins, Ulster, Warren, Washington, Wayne, Westchester, Wyoming, Yates

**WAGES**

	07/01/2021
Metal Polisher	\$ 37.13
Metal Polisher*	38.23
Metal Polisher**	41.13

\*Note: Applies on New Construction & complete renovation  
 \*\* Note: Applies when working on scaffolds over 34 feet.

**SUPPLEMENTAL BENEFITS**

Per Hour:	07/01/2021
Journeyworker: All classification	\$ 10.64

**OVERTIME PAY**

See (B, E, P, T) on OVERTIME PAGE

**HOLIDAY**

Paid: See (5, 6, 11, 15, 16, 25, 26) on HOLIDAY PAGE  
 Overtime: See (5, 6, 9, 11, 15, 16, 25, 26) on HOLIDAY PAGE

**REGISTERED APPRENTICES**

Wages per hour:

One (1) year term at the following wage rates:

	07/01/2021
1st year	\$ 16.00
2nd year	17.00
3rd year	18.00
1st year*	\$ 16.39
2nd year*	17.44
3rd year*	18.54
1st year**	\$ 18.50
2nd year**	19.50
3rd year**	20.50

\*Note: Applies on New Construction & complete renovation  
 \*\* Note: Applies when working on scaffolds over 34 feet.



Supplemental benefits:  
Per hour:

1st year	\$ 7.39
2nd year	7.39
3rd year	7.39

8-8A/28A-MP

---

**Plumber**

**05/01/2022**

**JOB DESCRIPTION** Plumber

**DISTRICT 8**

**ENTIRE COUNTIES**

Putnam, Westchester

**WAGES**

Per hour:

07/01/2021

Plumber and  
Steamfitter

\$ 59.01

**SHIFT WORK:**

When directly specified in public agency or authority contract documents, shift work outside the regular hours of work shall be comprised of eight (8) hours per shift not including Saturday, Sundays and holidays. One half (1/2) hour shall be allowed for lunch after the first four (4) hours of each shift. Wage and Fringes for shift work shall be straight time plus a shift premium of twenty-five (25%) percent. A minimum of five days Monday through Friday must be worked to establish shift work.

**SUPPLEMENTAL BENEFITS**

Per hour:

Journeyworker \$ 39.26

**OVERTIME PAY**

See (B, E, E2, Q, V) on OVERTIME PAGE

OVERTIME:.... See on OVERTIME PAGE.

**HOLIDAY**

Paid: See (1) on HOLIDAY PAGE

Overtime: See (5, 6, 8, 16, 25) on HOLIDAY PAGE

**REGISTERED APPRENTICES**

(1)year terms at the following wages:

1st Term	\$ 21.89
2nd Term	25.13
3rd Term	29.01
4th Term	41.43
5th Term	44.45

Supplemental Benefits per hour:

1st term	\$ 16.25
2nd term	18.13
3rd term	21.57
4th term	28.41
5th term	30.11

8-21.1-ST

---

**Plumber - HVAC / Service**

**05/01/2022**

**JOB DESCRIPTION** Plumber - HVAC / Service

**DISTRICT 8**

**ENTIRE COUNTIES**

Dutchess, Putnam, Westchester

**PARTIAL COUNTIES**

Delaware: Only the townships of Middletown and Roxbury

Ulster: Entire County(including Wallkill and Shawangunk Prisons) except for remainder of Town of Shawangunk and Towns of Plattekill, Marlboro, and Wawarsing.

**WAGES**

Per hour:

07/01/2021

HVAC Service

\$ 40.68

+ \$ 4.32\*

\*Note: This portion of wage is not subject to overtime premium.

**SUPPLEMENTAL BENEFITS**

Per hour:

07/01/2021

Journeyworker HVAC Service

\$ 26.54

**OVERTIME PAY**

See (B, F, R) on OVERTIME PAGE

**HOLIDAY**

Paid: See (5, 6, 16, 25) on HOLIDAY PAGE

Overtime: See (5, 6, 16, 25) on HOLIDAY PAGE

**REGISTERED APPRENTICES**

HVAC SERVICE

(1)year terms at the following wages:

1st yr.	2nd yr.	3rd yr.	4th yr.	5th yr.
\$ 18.50	\$ 21.88	\$ 27.31	\$ 33.56	\$ 36.36
+\$2.37*	+\$2.67*	+\$3.22*	+\$3.84*	+\$4.07*

\*Note: This portion of wage is not subject to overtime premium.

Supplemental Benefits per hour:

Apprentices 07/01/2021

1st term	\$ 19.66
2nd term	20.86
3rd term	22.21
4th term	24.02
5th term	25.33

8-21.1&2-SF/Re/AC

**Plumber - Jobbing & Alterations**

**05/01/2022**

**JOB DESCRIPTION** Plumber - Jobbing & Alterations

**DISTRICT 8**

**ENTIRE COUNTIES**

Dutchess, Putnam, Westchester

**PARTIAL COUNTIES**

Ulster: Entire county (including Walkill and Shawangunk Prisons in Town of Shawangunk) EXCEPT for remainder of Town of Shawangunk, and Towns of Plattekill, Marlboro, and Wawarsing.

**WAGES**

Per hour: 07/01/2021

Journeyworker: \$ 45.83

Repairs, replacements and alteration work is any repair or replacement of a present plumbing system that does not change existing roughing or water supply lines.

**SHIFT WORK:**

When directly specified in public agency or authority contract documents, shift work outside the regular hours of work shall be comprised of eight (8) hours per shift not including Saturday, Sundays and holidays. One half (1/2) hour shall be allowed for lunch after the first four (4) hours of each shift. Wage and Fringes for shift work shall be straight time plus a shift premium of twenty-five (25%) percent. A minimum of five days Monday through Friday must be worked to establish shift work.

**SUPPLEMENTAL BENEFITS**

Per hour:

Journeyworker

\$ 32.96

**OVERTIME PAY**

See (B, \*E, E2, Q, V) on OVERTIME PAGE

\*When used as a make-up day, hours after 8 on Saturday shall be paid at time and one half.

**HOLIDAY**

Paid: See (1) on HOLIDAY PAGE  
 Overtime: See (5, 6, 8, 16, 25) on HOLIDAY PAGE

**REGISTERED APPRENTICES**

(1) year terms at the following wages:

1st year	\$ 19.88
2nd year	22.06
3rd year	23.90
4th year	33.57
5th year	35.46

Supplemental Benefits per hour:

1st year	\$ 10.74
2nd year	12.65
3rd year	16.58
4th year	22.39
5th year	24.32

8-21.3-J&A

---

**Roofer** **05/01/2022**

---

**JOB DESCRIPTION** Roofer **DISTRICT 9**

**ENTIRE COUNTIES**  
 Bronx, Dutchess, Kings, New York, Orange, Putnam, Queens, Richmond, Rockland, Sullivan, Ulster, Westchester

**WAGES**

Per Hour: 07/01/2021

Roofer/Waterproofers \$ 45.25  
 + \$7.00\*

\* This portion is not subjected to overtime premiums.

Note: Abatement/Removal of Asbestos containing roofs and roofing material is classified as Roofer.

**SUPPLEMENTAL BENEFITS**

Per Hour: \$ 28.62

**OVERTIME PAY**

See (B, H) on OVERTIME PAGE

Note: An observed holiday that falls on a Sunday will be observed the following Monday.

**HOLIDAY**

Paid: See (1) on HOLIDAY PAGE  
 Overtime: See (5, 6) on HOLIDAY PAGE

**REGISTERED APPRENTICES**

( 1 ) year term

	1st	2nd	3rd	4th
	\$ 15.84	\$ 22.63	\$ 27.15	\$ 33.94
		+ 3.50*	+ 4.20*	+ 5.26*

Supplements:

	1st	2nd	3rd	4th
	\$ 3.72	\$ 14.47	\$ 17.30	\$ 21.55

9-8R

---

**Sheetmetal Worker** **05/01/2022**

---

**JOB DESCRIPTION** Sheetmetal Worker **DISTRICT 8**

**ENTIRE COUNTIES**  
 Dutchess, Orange, Putnam, Rockland, Sullivan, Ulster, Westchester

**WAGES**

07/01/2021  
 SheetMetal Worker \$ 44.15  
 + 3.37\*

\*This portion is not subject to overtime premiums.

**SHIFT WORK**

For all NYS D.O.T. and other Governmental mandated off-shift work:  
 10% increase for additional shifts for a minimum of five (5) days

**SUPPLEMENTAL BENEFITS**

Journeyworker \$ 44.20

**OVERTIME PAY**

OVERTIME:.. See ( B, E, Q, ) on OVERTIME PAGE.

**HOLIDAY**

Paid: See (1) on HOLIDAY PAGE  
 Overtime: See (5, 6, 8, 15, 16, 23) on HOLIDAY PAGE

**REGISTERED APPRENTICES**

1st	2nd	3rd	4th	5th	6th	7th	8th
\$ 16.36	\$ 18.41	\$ 20.46	\$ 22.51	\$ 24.54	\$ 26.60	\$ 29.12	\$ 31.65
+ 1.35*	+ 1.52*	+ 1.69*	+ 1.85*	+ 2.02*	+ 2.19*	+ 2.36*	+ 2.53*

\*This portion is not subject to overtime premiums.

Supplemental Benefits per hour:

**Apprentices**

1st term	\$ 18.96
2nd term	21.34
3rd term	23.71
4th term	26.11
5th term	28.46
6th term	30.82
7th term	32.72
8th term	34.64

8-38

**Sheetmetal Worker**

**05/01/2022**

**JOB DESCRIPTION** Sheetmetal Worker

**DISTRICT 4**

**ENTIRE COUNTIES**

Bronx, Kings, Nassau, New York, Queens, Richmond, Rockland, Suffolk, Westchester

**WAGES**

Per Hour: 07/01/2021 8/01/2021

Sign Erector \$ 52.29 \$ 53.97

NOTE: Structurally Supported Overhead Highway Signs(See STRUCTURAL IRON WORKER CLASS)

**SUPPLEMENTAL BENEFITS**

Per Hour: 07/01/2021 8/01/2021

Sign Erector \$ 51.26 \$ 53.15

**OVERTIME PAY**

See (A, F, S) on OVERTIME PAGE

**HOLIDAY**

Paid: See (5, 6, 10, 11, 12, 16, 25) on HOLIDAY PAGE  
 Overtime: See (5, 6, 10, 11, 12, 16, 25) on HOLIDAY PAGE

**REGISTERED APPRENTICES**

Per Hour:  
 6 month Terms at the following percentage of Sign Erectors wage rate:

1st	2nd	3rd	4th	5th	6th	7th	8th	9th	10th
35%	40%	45%	50%	55%	60%	65%	70%	75%	80%

**SUPPLEMENTAL BENEFITS**

Per Hour:

07/01/2021

1st	2nd	3rd	4th	5th	6th	7th	8th	9th	10th
\$ 14.34	\$ 16.26	\$ 18.17	\$ 20.10	\$ 28.02	\$ 30.47	\$ 33.72	\$ 36.27	\$ 38.77	\$ 41.29

8/01/2021

1st	2nd	3rd	4th	5th	6th	7th	8th	9th	10th
\$ TBD	\$ TBD	\$ TBD	\$ TBD	\$ TBD	\$ TBD	\$ TBD	\$ TBD	\$ TBD	\$ TBD

4-137-SE

---

**Sprinkler Fitter** **05/01/2022**

---

**JOB DESCRIPTION** Sprinkler Fitter **DISTRICT 1**

**ENTIRE COUNTIES**  
 Dutchess, Orange, Putnam, Rockland, Sullivan, Ulster, Westchester

**WAGES**  
 Per hour 07/01/2021

Sprinkler Fitter \$ 47.19

**SUPPLEMENTAL BENEFITS**  
 Per hour

Journey person \$ 28.09

**OVERTIME PAY**  
 See (B, E, Q) on OVERTIME PAGE

**HOLIDAY**  
 Paid: See (1) on HOLIDAY PAGE  
 Overtime: See (5, 6) on HOLIDAY PAGE

Note: When a holiday falls on Sunday, the following Monday shall be considered a holiday and all work performed on either day shall be at the double time rate. When a holiday falls on Saturday, the preceding Friday shall be considered a holiday and all work performed on either day shall be at the double time rate.

**REGISTERED APPRENTICES**  
 Wages per hour

One Half Year terms at the following wage.

1st	2nd	3rd	4th	5th	6th	7th	8th	9th	10th
\$ 22.67	\$ 25.19	\$ 27.46	\$ 29.98	\$ 32.50	\$ 35.02	\$ 37.54	\$ 40.05	\$ 42.57	\$ 45.09

Supplemental Benefits per hour

1st	2nd	3rd	4th	5th	6th	7th	8th	9th	10th
\$ 8.27	\$ 8.27	\$ 19.22	\$ 19.22	\$ 19.47	\$ 19.47	\$ 19.47	\$ 19.47	\$ 19.47	\$ 19.47 1-669.2

---

**Teamster - Building / Heavy&Highway** **05/01/2022**

---

**JOB DESCRIPTION** Teamster - Building / Heavy&Highway **DISTRICT 8**

**ENTIRE COUNTIES**  
 Putnam, Westchester

**WAGES**  
 GROUP A: Straight Trucks (6-wheeler and 10-wheeler), A-frame, Winch, Dynamite Seeding, Mulching, Agitator, Water, Attenuator, Light Towers, Cement (all types), Suburban, Station Wagons, Cars, Pick Ups, any vehicle carrying materials of any kind.  
 GROUP AA: Tack Coat  
 GROUP B: Tractor & Trailers (all types).  
 GROUP BB: Tri-Axle, 14 Wheeler  
 GROUP C: Low Boy (carrying equipment).  
 GROUP D: Fuel Trucks, Tire Trucks.  
 GROUP E: Off-road Equipment (over 40 tons): Athey Wagons, Belly Dumps, Articulated Dumps, Trailer Wagons.  
 GROUP F: Off-road Equipment (over 40 tons) Euclid, DJB.  
 GROUP G: Off-road Equipment (under 40 tons) Athey Wagons, Belly Articulated Dumps, Trailer Wagons.  
 GROUP H: Off-road Equipment (under 40 tons), Euclid.  
 GROUP HH: Off-road Equipment (under 40 tons) D.J.B.  
 GROUP I: Off-road Equipment (under 40 tons) Darts.  
 GROUP II: Off-road Equipment (under 40 tons) RXS.

WAGES:(per hour) 07/01/2021

GROUP A \$ 42.47\*

GROUP AA	45.27*
GROUP B	43.09*
GROUP BB	42.59*
GROUP C	45.22*
GROUP D	42.92*
GROUP E	43.47*
GROUP F	44.47*
GROUP G	43.22*
GROUP H	43.84*
GROUP HH	44.22*
GROUP I	43.97*
GROUP II	44.34*

\* To calculate premium wage, subtract \$ .20 from the hourly wage.

Note: Fuel truck operators on construction sites addit. \$5.00 per day.  
For work on hazardous/toxic waste site addit. 20% of hourly rate.

Shift Differential: When mandated by the contracting agency, DOT, or any governmental agency contracts shall receive a shift differential of fifteen (15%) above the wage rate.

Four (4), ten (10) hour days may be worked at straight time during a week, Monday thru Thursday.

NOTE - In order to use the '4 Day/10 Hour Work schedule', as your normal schedule, you must submit an 'Employer Registration for Use of 4 Day/10 Hour Work Schedule,' form PW30.1; and there must be a dispensation of hours in place on the project. If the PW30.1 is not submitted you may be liable for overtime payments for work over 8 hours per day.

**SUPPLEMENTAL BENEFITS**

Per hour:

Journeyworker

First 40 hours	\$ 33.64
41st-45th hours	15.18
Over 45 hours	0.26

**OVERTIME PAY**

See (B, E, P, R) on OVERTIME PAGE

**HOLIDAY**

Paid: See (5, 6, 8, 9, 15, 25) on HOLIDAY PAGE  
Overtime: See (5, 6, 8, 9, 15, 25) on HOLIDAY PAGE

8-456

**Welder**

**05/01/2022**

**JOB DESCRIPTION** Welder

**DISTRICT 1**

**ENTIRE COUNTIES**

Albany, Allegany, Bronx, Broome, Cattaraugus, Cayuga, Chautauqua, Chemung, Chenango, Clinton, Columbia, Cortland, Delaware, Dutchess, Erie, Essex, Franklin, Fulton, Genesee, Greene, Hamilton, Herkimer, Jefferson, Kings, Lewis, Livingston, Madison, Monroe, Montgomery, Nassau, New York, Niagara, Oneida, Onondaga, Ontario, Orange, Orleans, Oswego, Otsego, Putnam, Queens, Rensselaer, Richmond, Rockland, Saratoga, Schenectady, Schoharie, Schuyler, Seneca, St. Lawrence, Steuben, Suffolk, Sullivan, Tioga, Tompkins, Ulster, Warren, Washington, Wayne, Westchester, Wyoming, Yates

**WAGES**

Per hour 07/01/2021

Welder: To be paid the same rate of the mechanic performing the work.\*

\*EXCEPTION: If a specific welder certification is required, then the 'Certified Welder' rate in that trade tag will be paid.

**OVERTIME PAY**

**HOLIDAY**

1-As Per Trade

## Overtime Codes

Following is an explanation of the code(s) listed in the OVERTIME section of each classification contained in the attached schedule. Additional requirements may also be listed in the HOLIDAY section.

NOTE: Supplemental Benefits are 'Per hour worked' (for each hour worked) unless otherwise noted

- ( AA ) Time and one half of the hourly rate after 7 and one half hours per day
- ( A ) Time and one half of the hourly rate after 7 hours per day
- ( B ) Time and one half of the hourly rate after 8 hours per day
- ( B1 ) Time and one half of the hourly rate for the 9th & 10th hours week days and the 1st 8 hours on Saturday.  
Double the hourly rate for all additional hours
- ( B2 ) Time and one half of the hourly rate after 40 hours per week
- ( C ) Double the hourly rate after 7 hours per day
- ( C1 ) Double the hourly rate after 7 and one half hours per day
- ( D ) Double the hourly rate after 8 hours per day
- ( D1 ) Double the hourly rate after 9 hours per day
- ( E ) Time and one half of the hourly rate on Saturday
- ( E1 ) Time and one half 1st 4 hours on Saturday; Double the hourly rate all additional Saturday hours
- ( E2 ) Saturday may be used as a make-up day at straight time when a day is lost during that week due to inclement weather
- ( E3 ) Between November 1st and March 3rd Saturday may be used as a make-up day at straight time when a day is lost during that week due to inclement weather, provided a given employee has worked between 16 and 32 hours that week
- ( E4 ) Saturday and Sunday may be used as a make-up day at straight time when a day is lost during that week due to inclement weather
- ( E5 ) Double time after 8 hours on Saturdays
- ( F ) Time and one half of the hourly rate on Saturday and Sunday
- ( G ) Time and one half of the hourly rate on Saturday and Holidays
- ( H ) Time and one half of the hourly rate on Saturday, Sunday, and Holidays
- ( I ) Time and one half of the hourly rate on Sunday
- ( J ) Time and one half of the hourly rate on Sunday and Holidays
- ( K ) Time and one half of the hourly rate on Holidays
- ( L ) Double the hourly rate on Saturday
- ( M ) Double the hourly rate on Saturday and Sunday
- ( N ) Double the hourly rate on Saturday and Holidays
- ( O ) Double the hourly rate on Saturday, Sunday, and Holidays
- ( P ) Double the hourly rate on Sunday
- ( Q ) Double the hourly rate on Sunday and Holidays
- ( R ) Double the hourly rate on Holidays
- ( S ) Two and one half times the hourly rate for Holidays

- ( S1 ) Two and one half times the hourly rate the first 8 hours on Sunday or Holidays One and one half times the hourly rate all additional hours.
- ( T ) Triple the hourly rate for Holidays
- ( U ) Four times the hourly rate for Holidays
- ( V ) Including benefits at SAME PREMIUM as shown for overtime
- ( W ) Time and one half for benefits on all overtime hours.
- ( X ) Benefits payable on Paid Holiday at straight time. If worked, additional benefit amount will be required for worked hours. (Refer to other codes listed.)



## Holiday Codes

### PAID Holidays:

Paid Holidays are days for which an eligible employee receives a regular day's pay, but is not required to perform work. If an employee works on a day listed as a paid holiday, this remuneration is in addition to payment of the required prevailing rate for the work actually performed.

### OVERTIME Holiday Pay:

Overtime holiday pay is the premium pay that is required for work performed on specified holidays. It is only required where the employee actually performs work on such holidays. The applicable holidays are listed under HOLIDAYS: OVERTIME. The required rate of pay for these covered holidays can be found in the OVERTIME PAY section listings for each classification.

Following is an explanation of the code(s) listed in the HOLIDAY section of each classification contained in the attached schedule. The Holidays as listed below are to be paid at the wage rates at which the employee is normally classified.

- ( 1 ) None
- ( 2 ) Labor Day
- ( 3 ) Memorial Day and Labor Day
- ( 4 ) Memorial Day and July 4th
- ( 5 ) Memorial Day, July 4th, and Labor Day
- ( 6 ) New Year's, Thanksgiving, and Christmas
- ( 7 ) Lincoln's Birthday, Washington's Birthday, and Veterans Day
- ( 8 ) Good Friday
- ( 9 ) Lincoln's Birthday
- ( 10 ) Washington's Birthday
- ( 11 ) Columbus Day
- ( 12 ) Election Day
- ( 13 ) Presidential Election Day
- ( 14 ) 1/2 Day on Presidential Election Day
- ( 15 ) Veterans Day
- ( 16 ) Day after Thanksgiving
- ( 17 ) July 4th
- ( 18 ) 1/2 Day before Christmas
- ( 19 ) 1/2 Day before New Years
- ( 20 ) Thanksgiving
- ( 21 ) New Year's Day
- ( 22 ) Christmas
- ( 23 ) Day before Christmas
- ( 24 ) Day before New Year's
- ( 25 ) Presidents' Day
- ( 26 ) Martin Luther King, Jr. Day
- ( 27 ) Memorial Day
- ( 28 ) Easter Sunday

( 29 )      Juneteenth



**New York State Department of Labor - Bureau of Public Work  
State Office Building Campus  
Building 12 - Room 130  
Albany, New York 12240**

**REQUEST FOR WAGE AND SUPPLEMENT INFORMATION**

As Required by Articles 8 and 9 of the NYS Labor Law

Fax (518) 485-1870 or mail this form for new schedules or for determination for additional occupations.

**This Form Must Be Typed**

Submitted By: \_\_\_\_\_

(Check Only One)

- Contracting Agency     Architect or Engineering Firm     Public Work District Office    Date: \_\_\_\_\_

**A. Public Work Contract to be let by:** (Enter Data Pertaining to Contracting/Public Agency)

1. Name and complete address  (Check if new or change)

Telephone: (    )

Fax: (    )

E-Mail: \_\_\_\_\_

2. NY State Units (see Item 5)

- |   |  |
|---|--|
| <input type="checkbox"/> 01 DOT                                   | <input type="checkbox"/> 07 City   |
| <input type="checkbox"/> 02 OGS                                   | <input type="checkbox"/> 08 Local School District  |
| <input type="checkbox"/> 03 Dormitory Authority                   | <input type="checkbox"/> 09 Special Local District, i.e.,<br>Fire, Sewer, Water District |
| <input type="checkbox"/> 04 State University<br>Construction Fund | <input type="checkbox"/> 10 Village  |
| <input type="checkbox"/> 05 Mental Hygiene<br>Facilities Corp.    | <input type="checkbox"/> 11 Town   |
| <input type="checkbox"/> 06 OTHER N.Y. STATE UNIT                 | <input type="checkbox"/> 12 County   |
|   | <input type="checkbox"/> 13 Other Non-N.Y. State<br>(Describe)                           |

3. SEND REPLY TO  check if new or change)  
Name and complete address: \_\_\_\_\_

Telephone:(    )

Fax: (    )

E-Mail: \_\_\_\_\_

4. SERVICE REQUIRED. Check appropriate box and provide project information.

New Schedule of Wages and Supplements.

APPROXIMATE BID DATE : \_\_\_\_\_

Additional Occupation and/or Redetermination

PRC NUMBER ISSUED PREVIOUSLY FOR  
THIS PROJECT : \_\_\_\_\_

OFFICE USE ONLY

**B. PROJECT PARTICULARS**

5. Project Title \_\_\_\_\_

Description of Work \_\_\_\_\_

Contract Identification Number \_\_\_\_\_

Note: For NYS units, the OSC Contract No. \_\_\_\_\_

6. Location of Project:  
Location on Site \_\_\_\_\_

Route No/Street Address \_\_\_\_\_

Village or City \_\_\_\_\_

Town \_\_\_\_\_

County \_\_\_\_\_

7. Nature of Project - Check One:

- 1. New Building
- 2. Addition to Existing Structure
- 3. Heavy and Highway Construction (New and Repair)
- 4. New Sewer or Waterline
- 5. Other New Construction (Explain)
- 6. Other Reconstruction, Maintenance, Repair or Alteration
- 7. Demolition
- 8. Building Service Contract

8. OCCUPATION FOR PROJECT :

- |  |   |
|--|---|
| <input type="checkbox"/> Construction (Building, Heavy<br>Highway/Sewer/Water) | <input type="checkbox"/> Guards, Watchmen                                   |
| <input type="checkbox"/> Tunnel  | <input type="checkbox"/> Janitors, Porters, Cleaners,<br>Elevator Operators |
| <input type="checkbox"/> Residential   | <input type="checkbox"/> Moving furniture and<br>equipment                  |
| <input type="checkbox"/> Landscape Maintenance                                 | <input type="checkbox"/> Trash and refuse removal                           |
| <input type="checkbox"/> Elevator maintenance                                  | <input type="checkbox"/> Window cleaners                                    |
| <input type="checkbox"/> Exterminators, Fumigators                             | <input type="checkbox"/> Other (Describe)                                   |
| <input type="checkbox"/> Fire Safety Director, NYC Only                        |   |

9. Has this project been reviewed for compliance with the Wicks Law involving separate bidding? YES  NO

10. Name and Title of Requester \_\_\_\_\_

**Signature**



## GENERAL CONDITIONS

### **ARTICLE 1 - SCOPE AND INTENT**

Work Described. The Contractor shall furnish all labor, materials, plant, power, light, heat, fuel, water, tools, appliances, equipment, supplies and other means of construction necessary or proper for performing and completing the Work in accordance with the Contract. The Contractor shall also obtain and pay for all required permits to complete the Work. Any labor, materials and equipment that have been omitted in the description of the Work, but that are necessary or proper for the completion of the Work, shall be furnished by the Contractor at its sole cost and expense. The Contractor shall protect the Work during construction, clean up the Site and maintain the Work until Final Acceptance.

Incidental work. The Contractor shall perform all tasks and pay all costs of cutting, protecting, supporting, maintaining, relocating and restoring all surface, sub-surface, and/or overhead structures, and all other property, including, but not limited to, pipes, conduits, ducts, tubes, chambers, and appurtenances, public or private, in the vicinity of and at the Site of the Work (except that which by law, franchise, permit, contract, consent or other agreement, the owner thereof is required to protect, support, maintain, relocate or restore), repair the same if damaged and restore to their original condition all areas disturbed. The Contractor shall perform all tasks and pay all costs of protecting, supporting, maintaining, relocating, replacing and restoring street equipment owned by the City and under the jurisdiction of the New York City Department of Transportation (“NYCDOT”), whether attached to utility company structures or connected to the underground electrical distribution system, including installing suitable temporary lighting equipment when the maintenance of permanent equipment is not feasible. All work done in connection with street lighting shall be in accordance with the requirements of NYCDOT or, for projects outside the City of New York, a local Authority Having Jurisdiction (“AHJ”) over such work.

Duties of the Contractor. The Contractor shall ensure that the requirements of the Contract, including but not limited to, the Contract Drawings and Specifications, are fully and faithfully complied with by all subcontractors, materialmen and workmen at all times, that all of this Work is prosecuted with the utmost diligence, and that all materials are provided promptly in sufficient quantities in order not to delay the Work. The Contractor shall exercise the closest inspection of all materials delivered, promptly returning defective materials without waiting for their rejection by the Engineer. The Contractor shall also become thoroughly familiar with the Contract Drawings and Specifications and shall promptly report to the Engineer all errors, discrepancies or omissions discovered therein. The Contractor shall abide by the decisions and explanations of the Engineer made in regard to such matters.

Contractor Assumes Risk of Loss or Damage. The Contractor agrees to assume the risk and to make no claim on account of any and all loss or damage arising out of the nature of the Work to be done under this Contract, or for any unforeseen obstructions or difficulties which may be encountered in the prosecution of the same, or from the effect of the elements, or from encumbrances on or near the line of the Work.

Local Laws. All materials, appliances and types or methods of construction shall be in accordance with the Contract and shall in no event be less than that necessary to conform to the requirements of the New York City Administrative Code, the Charter of the City of

New York (the “City Charter”), the Rules of the City of New York, and/or the applicable laws and rules of AHJs if the Work occurs outside the City of New York.

Ample quantities. The Contractor shall deliver materials in ample quantities to ensure speedy and uninterrupted progress of the Work in order to complete the Work within the Contract term.

Work and materials. All Work and materials mentioned in the Specifications and not shown on the Contract Drawings, and all Work and materials shown on the Contract Drawings and not mentioned in the Specifications, are to be furnished and performed as if the same were both mentioned in the Specifications and shown on the Contract Drawings.

Necessary and essential Work deemed included. In case any Work or materials shall be required for the more perfect performance of the Work, which are not specifically mentioned, specified or indicated on the Contract Drawings, in the Specifications, or other parts of this Contract, and which in the opinion of the Engineer are necessary and essential to a complete performance of this Contract, such Work or materials shall be deemed included within the requirements of this Contract. The Contractor hereby specifically promises, covenants and agrees to do and perform any and all such Work and to supply any and all such materials as if specifically provided for in this Contract.

Purport of schedules. All schedules are given for the convenience of the Engineer and the Contractor and are not guaranteed to be complete. The Contractor shall assume all responsibility for the making of estimates of the size, kind and quality of materials and equipment included in Work to be performed under this Contract.

Order of Precedence. In the event of an actual conflict among the City of New York Standard Construction Contract, General Conditions, and the Contract Drawings and Specifications, the City of New York Standard Construction Contract will control, followed by the General Conditions, followed by the Contract Drawings and Specifications.

Conflicts between Contract Drawings and Specifications. If the Contract Drawings and/or the Specifications are in conflict, or, if the Contract Drawings or the Specifications, or both the Contract Drawings and the Specifications are not clear as to (a) the method of performing any part of the Work; (b) the types of materials or equipment necessary to perform the Work; or (c) the quantities required, the Contractor shall be deemed to have based its bid upon performing the Work and furnishing materials or equipment in the manner most expensive to the Contractor. If DEP determines that such conflict(s) exist or that a clarification is needed, the DEP will furnish the Contractor with supplementary drawings and/or specifications to address such conflict(s) or necessary clarification. In such event, the Contractor agrees to execute the Work in accordance with such interpretation, and to make no charge or claim for any extra or additional work or damage on account of such interpretation.

Understanding of the Contract Drawings and Specifications. The Contractor expressly declares and acknowledges that, before the signing of this Contract, it has carefully read the entire Contract, together and in connection with the Contract Drawings and Specifications, and that through such reading, the Contractor can determine the Work required pursuant to this Contract. The Contractor agrees that it will not hereafter make any claim or demand upon the City based upon or arising out of any alleged

misunderstanding or misconception of the said requirements, covenants, stipulations and restrictions of the Contract.

Deviations from Contract Drawings and Specifications. No deviation from the Contract Drawings and Specifications will be allowed, unless the same has been previously authorized in writing by the Commissioner or his/her designee.

**ARTICLE 2 - PROVISIONS REFERENCED WITH INFORMATION FOR  
BIDDERS AND THE CITY OF NEW YORK STANDARD  
CONSTRUCTION CONTRACT**

(A) SCHEDULE "A" AND LIQUIDATED DAMAGES

1. Schedule "A" requirements for the Contract follow these General Conditions.
2. In view of the difficulty of accurately ascertaining the loss(es) which the City will suffer because of the Contractor exceeding substantial completion time for the Work, or failing to complete a designated milestone within the scheduled time for completion of such milestone, or failing to meet other requirements for which liquidated damages have been provided, the amounts set forth in Schedule A are hereby fixed and agreed to as liquidated damages that the City will suffer by reason of any such failure, and not as a penalty. The City of New York Standard Construction Contract, incorporated herein, shall govern with respect to assessment of all liquidated damages provided for in this Contract, not just those for failure to timely achieve substantial completion, unless specifically detailed in a Specification where any individual liquidated damages are specified.

(B) FEDERAL EXCISE TAXES

Pursuant to Section 37 of the "Information for Bidders", the Contractor may be exempted from the payment of Federal Excise Taxes in accord with the following:

1. An Excise Tax Exemption Certificate will be provided by DEP where requested by the Contractor, for items that fall within the scope of the Contract and may be exempt from the Federal Excise Tax.

(C) LABOR

Where labor is used under the Contract for intermediate skills and for which no prevailing rate of wages is herein certified, and where there is in existence at the time the Contract is entered into a labor agreement between the Contractor and a duly recognized labor union recognizing the existence of such skills, the Contractor shall pay not less than the rate so agreed upon between the Contractor and such labor organization for such skills.

(D) PARTIAL PAYMENTS FOR MATERIALS IN ADVANCE OF THEIR  
INCORPORATION IN THE WORK PURSUANT TO ARTICLE 42 OF THE  
CITY OF NEW YORK STANDARD CONSTRUCTION CONTRACT

In order to better ensure the availability of materials, fixtures and equipment when needed for the Work, the Commissioner may authorize partial payment for certain materials, fixtures and equipment, prior to their incorporation in the Work, but only in

strict accordance with and subject to all the terms and conditions set forth in the following subdivisions numbered 1 to 15, unless another method of payment is elsewhere provided in the Specifications for specified materials, fixtures or equipment. For purposes of this Article 2(D), when the term "materials" is used, it shall also apply to fixtures and/or equipment.

1. The Contractor shall submit to the Commissioner a written request for payment for materials purchased or to be purchased for which the Contractor desires to be paid prior to their actual incorporation in the Work. The request shall be accompanied by a schedule of the types and quantities of materials, and shall state whether such materials are to be stored on or off the Site.
2. Where the materials are to be stored off the Site, they shall be stored at a place other than the Contractor's premises (except with the written consent of the Commissioner) and under the conditions prescribed or approved by the Commissioner. The Contractor shall set apart and separately store at the place or places of storage all materials and shall clearly mark same "Property of the City of New York", and shall not at any time move any of said materials to another off-site place of storage without the prior written consent of the Commissioner. Materials may be removed from their place of storage off the Site for incorporation in the Work upon approval of the Resident Engineer.
3. Where materials are to be stored at the Site, they shall be stored at such locations as shall be designated by the Resident Engineer and only in such quantities as, in the opinion of the Resident Engineer, will not interfere with the proper performance of the Work by the Contractor or by other contractors then engaged in performing Work on the Site. Such materials shall not be removed from their place of storage on the Site except for incorporation in the Work, without the approval of the Resident Engineer.
4. All costs, charges and expenses arising out of the storage of such materials shall be borne by the Contractor and the City hereby reserves the right to retain out of any partial or final payment made under the Contract an amount sufficient to cover such costs, charges and expenses. There shall be no increase in the Contract price for such costs, charges and expenses and the Contractor shall not make any claim or demand for compensation for provision of such storage.
5. The Contractor shall pay any and all costs of handling and delivery of materials to the place of storage, to any approved other place of storage, and from the place of storage to the Site of the Work and the City shall have the right to retain from any partial or final payment an amount sufficient to cover the cost of such handling and delivery.
6. In the event that the whole or any part of these materials are lost, damaged or destroyed in advance of their satisfactory incorporation in the Work, the Contractor, at its sole cost and expense, shall promptly replace such lost, damaged or destroyed materials with materials of the same character and quality.
7. Should any of the materials paid for by the City hereunder be subsequently rejected or incorporated in the Work in a manner not in accordance with the Contract, the Contractor shall remove and replace such rejected or improperly incorporated material with materials complying with the Contract. Until such materials are replaced, the City will deduct from the value of the materials or from



any other money due to the Contractor, the amount paid by the City for such rejected or improperly incorporated materials.

8. Payment for the cost of materials made hereunder shall not be deemed to be an acceptance of such materials in accordance with the Contract, and the Contractor always retains and must comply with its duty to deliver to the Site and properly incorporate into the Work only materials which comply with the Contract.

9. The Contractor shall retain any and all risks in connection with the damage, destruction or loss of the materials paid for hereunder to the time of delivery of the same to the Site of the Work and their proper incorporation in the Work in accordance with the Contract.

10. The Contractor shall comply with all applicable laws, rules and regulations of any governmental body or agency pertaining to the purchase, allocation and use of materials.

11. When requesting payment for such materials, the Contractor shall submit with the partial payment request, duly authenticated documents of title, such as bills of sale, invoices or warehouse receipts, all in quadruplicate. The Contractor shall provide along with its partial payment request for such materials, appropriate documentation transferring title to such materials from the Contractor to the City. In the event that the invoices state that the material has been purchased by a subcontractor, the Contractor shall also provide appropriate documentation demonstrating transfer of title to such materials from the subcontractor to the Contractor.

12. Where the Contractor, with the approval of the Commissioner, has purchased unusually large quantities of materials in order to assure their availability for the Work, the Commissioner, at his or her option, may waive the requirements of subdivision 11, provided the Contractor furnishes evidence in the form of an affidavit of the Contractor, and such other proof as the Commissioner may require, that it is the sole owner of such materials and has purchased them free and clear of all liens and other encumbrances. In such event, the Contractor shall pay for such materials and submit proof thereof, in the same manner as provided in subdivision 11 hereof, within seven (7) days after receipt of payment therefor. Failure on the part of the Contractor to submit satisfactory evidence that it has paid in full for all such materials shall preclude it from any payments under the Contract.

13. The Contractor shall include in any succeeding partial payment requisition a summary of materials stored which shall set forth the quantity and value of materials in storage, on or off the Site, at the end of each preceding payment period; the amount removed for incorporation in the Work; the quantity and value of materials delivered during the current period and the total value of materials on hand for which payment thereof will be included in the current payment requisition.

14. Upon proof to the satisfaction of the Commissioner of the actual cost of such materials and upon submission of proper proof of title as required under subdivisions 11 and/or 12 hereof, DEP will pay the Contractor Eighty Five Percent (85%) of the value of such materials, however, in no event shall the Eighty Five Percent (85%) payment exceed the estimated cost of such materials included in the approved detailed estimate breakdown submitted in accordance with Article 41 of the City of New York Standard Construction Contract; if the value exceeds such

estimated cost, the City will pay only Eighty Five Percent (85%) of such approved estimated cost.

15. Upon the incorporation in the Work of any such materials which have been paid for in advance of such incorporation in accordance with the foregoing provisions, payment will be made for such materials incorporated in the Work pursuant to Article 42 or Article 45 of the City of New York Standard Construction Contract, less any sums paid pursuant to subdivision 14 herein.

(E) CONFLICTS OF INTEREST

The City Charter in relation to conflicts of interest (Chapter 68, Section 2604) provides, among a number of safeguards, that:

(1) No employee or person whose salary is payable in whole or in part from the City treasury shall accept any valuable gift, whether in the form of service, loan, thing or promise, or any other form from any person, firm or corporation which to his or her knowledge is interested, directly or indirectly, in any manner whatsoever in business dealings with the City; and

(2) Any violation of any of the provisions of this section shall, at the option of the Comptroller, render forfeit and void the Contract, work, business, sale or transaction affected.

Other sections of the City Charter, the New York City Administrative Code and the New York State Penal Law are applicable in implementing the basic conflicts of interest section and under certain circumstances penalties may be invoked against the donor as well as the recipient of any form of valuable gift.

Notice is hereby given that sections of the City Charter, the New York City Administrative Code and the New York State Penal Law alluded to herein shall apply under the terms of this Contract to circumstances relevant to conflicts of interest and shall be extended in application to subcontractors authorized to perform Work, labor and services pursuant to this Contract and further it shall be the duty and responsibility of the Contractor to so inform its subcontractors.

**ARTICLE 3 – CONTRACT DRAWINGS AND SPECIFICATIONS**

Related contracts. The Contractor shall study the requirements of any related contracts insofar as they affect the Work or as the Work may affect that of the related contracts and the Contractor will be required to coordinate its Work with that of all other related contractors performing work on such related contracts. The Contractor shall coordinate deliveries in order to avoid delaying or impeding the progress of the Work of any related contractor.

Contract Drawings and Specifications furnished to Contractor. After the Contract has been executed, the Contractor will be furnished with four sets of paper prints of the Contract Drawings and four set of Specifications of the Contract. The Contractor will also be furnished with one set of paper prints and Specifications of any related contracts.

Additional copies. Additional sets of Contract Drawings and Specifications may be issued provided such documents are available in sufficient quantity.

Supplementary drawings. When the Engineer decides to show more fully the Work to be done, or to show required changes, or to rectify errors which may have been discovered, drawings to be known as supplementary drawings and revision sheets with Specifications pertaining thereto will be provided to the Contractor. Changes of a minor nature may be made on the Contract Drawings, in which case the revised Contract Drawings will be issued to the Contractor. The supplementary drawings and revised Contract Drawings shall be as fully binding as the original Contract Drawings, and if such supplementary or revised Contract Drawings require either less or more than the estimated quantities of work, credit to the City or compensation therefor to the Contractor shall be subject to the terms of the City of New York Standard Construction Contract.

Information to subcontractors, manufacturers and others. The Contractor shall furnish each of its subcontractors and materialmen copies of such portions of the Contract, together with all necessary drawings and copies of Specifications, as may be required for the portion of the Work that the respective subcontractors or materialmen shall be responsible for.

Contractor to check drawings and other data. The Contractor shall verify all dimensions, quantities and details shown on Contract Drawings, plans, sketches, schedules, or on any other data received from the Engineer and shall notify the Engineer of all errors, omissions, conflicts and discrepancies found therein.

Failure to discover or correct errors, conflicts or discrepancies shall not relieve the Contractor of full responsibility for unsatisfactory work, faulty construction or improper operation resulting therefrom nor from rectifying such conditions at its sole cost and expense. Figures shall be used in preference to scaled dimensions and large scale drawings in preference to small scale drawings.

"Directed", etc. Whenever reference is made in the Contract to the Work or its performance, the terms "directed", "required", "permitted", "ordered", "designated", "prescribed", "determined", and words of similar import shall imply the direction, requirement, permission, order, designation, or prescription of the Commissioner.

"Approved", etc. "Approved", "acceptable", "satisfactory", and words of similar import shall mean approved, acceptable or satisfactory to the Commissioner.

#### ARTICLE 4 - TEMPORARY STRUCTURES

Contractor's Field Office. The Contractor shall, during the period of construction, erect or provide for its own use a temporary field office in which readily accessible copies of all Contract Documents and approved Shop and Working Drawings shall be kept. The field office shall be located at the Site, where directed by the Engineer, and shall be provided with the equipment necessary for a functional field office, as approved by the Engineer.

Material Sheds. Material sheds used by the Contractor for the storage of tools, materials and equipment shall be kept at all locations so as not to interfere at any time with the progress of the Work, the location of which shall be subject to the absolute discretion of the Engineer.

Construction of Temporary Structures. All of the Contractor's temporary structures shall be fully constructed and have a neat appearance and shall be painted a uniform gray, unless another color is ordered by the Engineer.

Contractor's Sign. The Contractor shall post and keep posted at the Site, outside of the field office, exterior fence or wall, a legible sign with the full name and address of the Contractor, and the telephone numbers of responsible representatives of the Contractor who can be reached in the event of an emergency.

Private property. When the Contractor temporarily occupies property adjacent to the Work, it shall provide the Engineer with certified copies of agreements which permit the use of such land, unless such permission has been obtained by DEP prior to bidding.

Land for Contractor's use. The Engineer shall in all cases determine the portion of the Site to be used by the Contractor for storage, plant or other purposes.

Obstructions, access. The Contractor shall not obstruct any highway or access thereto from private property except as otherwise specified in the Specifications. The necessary facilities and safeguards to comply with this requirement shall be provided and maintained at the sole cost and expense of the Contractor. If it becomes necessary to remove and restack materials to avoid impeding the progress of any part of the Work or interfering with the work to be done by any other contractor, the Contractor shall remove and restack such materials at no additional cost to the City.

Trespassing prohibited. All employees and subcontractors of the Contractor are prohibited from trespassing on private or public property except where the law permits such entrance for a purpose such as underpinning or otherwise protecting adjoining structures. If it becomes necessary for employees of the Contractor or its subcontractor(s) to enter onto private property for the above stated reasons, the Contractor shall advise DEP of such need. Employees of the Contractor or subcontractor may not enter onto the property until the requisite permission has been obtained and proper notice furnished to the property owner.

#### ARTICLE 5 - CONTRACTOR'S SUPERINTENDENT

The Contractor shall employ and retain at the Site of the Work, from the commencement until the completion of the Work, a superintendent competent and capable of maintaining proper supervision and care of the Work and acceptable to the Engineer, and who, in the

absence of the Contractor and irrespective of any superintendent or foreman employed by any subcontractor, shall carry out the directions of the Engineer.

#### **ARTICLE 6 - SURVEYS**

Lines and grades. All Work shall be constructed according to the lines and grades shown on the Contract Drawings and approved by the Engineer. The Engineer will establish a baseline and benchmark. The Contractor shall establish all other lines, elevations and grades required for the Work and be solely responsible for the accuracy thereof. The Engineer shall be notified prior to the establishment of any line, elevation or grade.

Safeguarding marks. The Contractor shall safeguard all points, stakes, grade marks, monuments and bench marks made or established on the Work, re-establish same if disturbed and bear the entire expense of rectifying work improperly installed due to not maintaining, not protecting or removing without authorization such established points, stakes, marks and monuments.

Survey before completion of structure. The Contractor for general construction work shall file with the New York City Department of Buildings in the borough where Work is being done or with the New York City Department of Small Business Services, or the local AHJ, a survey by a duly licensed surveyor showing the location of the new structure before completion of the structure, pursuant to Section 28.118.4 of the New York City Building Code or applicable local codes or regulations for projects outside the City. This survey shall show the location of the structure, the elevation of the first tier of beams or of the first floor, the finished grades of the open spaces on the plot, the established curb level and the location of all other structures on the plot, together with the location and boundaries of the lot or plot upon which the structure is constructed. One copy of the application and the survey shall be furnished to the Resident Engineer.

#### **ARTICLE 7 - CONTRACTOR'S DAILY REPORTS**

As soon as the Contractor has started Work on the Project, it shall submit to the Engineer written daily reports of the Work performed the previous day by any of its employees, including the employees of its subcontractors.

The reports shall be prepared by the Contractor's Superintendent and shall bear his or her signature. Each report shall contain the following information:

1. The type of materials and/or major equipment being installed by the Contractor and the total number of employees working in each category on that particular day.
2. The names of the subcontractors working and the type of materials and/or major equipment being installed by each together with the total number of employees working for each subcontractor on that particular day.
3. The major construction equipment being used by the Contractor and/or any subcontractor.

#### **ARTICLE 8 – CONTRACTOR'S PLANT**

The Contractor shall ensure that it obtains, provides and maintains a sufficient construction plant in close proximity to the Work all times during the progress of the Work in order to meet the demands of the Work, with ample margin for emergencies or

overload. The plant shall be of such capacity conducive to ensure the completion of the Work within the time stipulated in the Contract.

The Contractor may occupy any unused location within the area controlled by DEP with its construction plant, subject to the approval of the Engineer. If the Contractor desires to use additional area outside of that controlled by DEP, the Contractor shall arrange for the use of such area at its sole cost and expense. The location of the Contractor's stationary and mobile equipment shall be subject to the Engineer's approval.

The Engineer shall have the right to reject or condemn any construction plant, staging area, which, in his/her opinion, is unsafe, improper or inadequate. Whether or not the Engineer exercises this right, the Contractor shall not be relieved from its sole responsibility for the safe, proper and lawful construction, maintenance and use of such construction plant, staging area, or for the adequacy of such plant.

The Contractor shall, at its sole cost and expense, stack and restack as needed, all Project materials at locations that are easily accessible and convenient to the Project Site and that do not impede the progress of the Work, or as directed by the Engineer. The Contractor shall also take appropriate measures required to secure and protect all such materials from loss. Should the Contractor wish to stack any project materials on publicly mapped streets, it shall comply with all applicable local, state and federal laws, rules and regulations.

#### **ARTICLE 9 - SECURITY GUARDS AND FIRE GUARDS ON THE SITE**

The requirements of the Contract for security guard services and the responsibilities of the Contractor for safeguarding and protecting the Work and Site shall be in accordance with, but not limited to, the respective Division 01 Specifications.

The Contractor will be responsible for safeguarding and protecting its own Work, materials, tools, and equipment. When the provision of security guards is required, each Security Guard shall be required to possess a "Certificate of Fitness" issued by the Fire Department to qualify and serve as a Fire Guard whenever the structure under construction, alteration, or demolition exceeds the prescribed area and height requirements specified in Rule 2.4.1 of the "Rules for Erection, Alteration, Repair, Excavation for and Demolition of Buildings" adopted by the New York City Board of Standards and Appeals under Calendar Number 784-41SR. Each Security Guard shall, during his or her tour of duty, perform the duties of Fire Guards in addition to his or her security obligations.

The use of watchdogs requires the express written approval of DEP and at DEP's sole discretion.

#### **ARTICLE 10 - CERTIFICATES OF OCCUPANCY AND/OR COMPLETION**

If the project structure is a building that is subject to the jurisdiction of the New York City Department of Buildings or similar local AHJ, before substantial completion of the project structure, the Commissioner will file an application for a Certificate of Occupancy or Certificate of Completion with the New York City Department of Buildings or New York City Department of Small Business Services or the local AHJ for project locations outside New York City, as applicable.

In connection with the application for Certificate of Occupancy or Certificate of Completion and before final payment is issued, the Contractor shall arrange for all final inspections by the inspection staffs of the New York City Department of Buildings, New York City Department of Small Business Services and other local AHJs for project locations outside New York City, as applicable, and shall do such remedial work and construction as is required and obtain all reports by such inspection staffs in order that the Certificate of Occupancy and/or Certificate of Completion or other similar certificate if occurring outside the City of New York be procured without delay.

#### **ARTICLE 11 - COORDINATION AMONG CONTRACTORS**

The Contractor is alerted to the importance of coordination and cooperation if other contractors are operating at or near the project Site. It is essential to the expeditious completion of this Project that the Contractor meet with any such other contractors at an early stage in the Work, to determine respective space requirements in areas where their operations or installations are in close proximity or are likely to be in conflict or interfere with each other, and to set up regular meetings as Shop Drawings are developed.

The Engineer will provide written notice of the time, place, and agenda of each such scheduled meeting.

The Contractor may also request a meeting by submitting a request for meeting to the Engineer.

Attendance at Coordination Meetings. To allow an orderly sequence of operations agreeable to all contractors, regular meetings shall be scheduled for the purpose of modifying work schedules and to address potential conflicts in work arrangements so that work stoppages and delays may be avoided. Coordination Meetings shall also be opportunities to prepare and circulate coordination drawings for the use and guidance of each contractor.

The Coordination Meetings will be arranged through the Engineer and shall be separate from and in addition to the regular job progress meetings. If it is desired that the architectural or engineering consultants be present at such meeting, this request should be directed to the Engineer.

The Contractor shall only send representatives to the meeting who have the competence and authority to make necessary decisions. Their statements shall commit the Contractor to the procedures, sequence of operations, and time schedules agreed upon.

The requirement to attend and effectively participate in all Progress and Coordination Meetings is subject to strict enforcement by the Commissioner. Failure to be represented at any of these meetings, when scheduled or approved by the Engineer, shall subject the Contractor to liability for any and all damages, delays, costs of alterations, etc., arising from the fact that it or its representatives were not present to coordinate its Work with the work that was scheduled, arrangements on or procedures developed at the meeting or meetings in question.

If, for compelling reasons, Contractor finds that its representative cannot attend a scheduled meeting, it shall give timely notice to the Engineer so that the meeting may be rescheduled.

Where procedures have been agreed upon and coordination drawings accepted by all contractors concerned, Contractor shall adhere to such drawings and procedures, both as to time and performance. No claim of delay or damages by a contractor, if it fails to comply, will be entertained by the Commissioner.

Contractor shall maintain at the Site sufficient competent personnel for the purpose of preparing layout and coordination drawings. Where such drawings are to be prepared by subcontractors, the subcontractor shall have the required personnel on Site in order to measure and assess proper, practical solutions found for problems arising from interferences, etc. and so that proper coordination among trades can be achieved.

#### **ARTICLE 12 - PUBLIC DISSEMINATION OF INFORMATION**

The Contractor agrees to hold confidential, both during and after the completion or termination of this Contract, all of the reports, information, or data, furnished to, or prepared, assembled or used by, the Contractor under this Contract. The Contractor agrees to maintain the confidentiality of such reports, information, or data by using a reasonable degree of care, and using at least the same degree of care that the Contractor uses to preserve the confidentiality of its own confidential information. The Contractor agrees that such reports, information, or data shall not be made available to any person or entity without the prior written approval of DEP. The obligation under this Article to hold reports, information or data confidential shall not apply where the Contractor is legally required to disclose such reports, information or data by virtue of a subpoena, court order or otherwise ("disclosure demand"), provided that the Contractor complies with the following: (1) the Contractor shall provide advance notice to the Commissioner, in writing or by e-mail, that it received a disclosure demand for such reports, information or data and (2) if requested by DEP, the Contractor shall not disclose such reports, information or data until the City has exhausted its legal rights, if any, to prevent disclosure of all or a portion of such reports, information, or data. The previous sentence shall not apply if the Contractor is prohibited by law from disclosing to DEP the disclosure demand for such reports, information or data.

The Contractor shall restrict access to confidential information to persons who have a legitimate work-related purpose to access such information. The Contractor agrees that it will instruct its officers, employees, and agents to maintain the confidentiality of any and all information required to be kept confidential by this Contract.

The Contractor, and its officers, employees, and agents shall notify DEP, at any time either during or after completion or termination of this Contract, of any intended statement to the press or any intended issuing of any material for publication in any media of communication (print, news, television, radio, Internet, etc.) regarding the services provided or the data collected pursuant to this Contract at least twenty-four (24) hours prior to any statement to the press or at least five (5) business days prior to the submission of the material for publication, or such shorter periods as are reasonable under the circumstances. The Contractor may not issue any statement or submit any material for publication that includes confidential information as prohibited by this Article.



**SCHEDULE A**

**GENERAL CONDITIONS TO CONSTRUCTION CONTRACT**  
**(INCLUDING GENERAL CONDITIONS RELATING TO ARTICLE 22 -- INSURANCE)**

**CONTRACT CRO-557G**

**PART I. REQUIRED INFORMATION**

<b><u>INFORMATION FOR BIDDERS</u></b> <b><u>BID BOND</u></b>	<u>5 %</u> of Bid
<u>The Contractor shall obtain a bid bond in the amount indicated to the right.</u>	
<b><u>INFORMATION FOR BIDDERS</u></b> <b><u>PERFORMANCE AND PAYMENT BONDS</u></b>	<u>100 %</u> of Bid
<u>The Contractor shall obtain performance and payment bonds in the amount indicated to the right.</u>	
<b><u>CONTRACT ARTICLE 14.</u></b> <b><u>DATE FOR SUBSTANTIAL COMPLETION</u></b>	<u>730</u> consecutive calendar days
<u>The Contractor shall substantially complete the Work in the number of calendar days indicated to the right.</u>	
<b><u>CONTRACT ARTICLE 15.</u></b> <b><u>LIQUIDATED DAMAGES</u></b>	\$ <u>1,000</u> for each consecutive calendar day over substantial completion time
<u>If the Contractor fails to substantially complete the Work within the time fixed for substantial completion plus authorized time extensions or if the Contractor, in the sole determination of the Commissioner, has abandoned the Work, the Contractor shall pay to the City the amount indicated to the right.</u>	
<u>Section 01321 – Progress Schedule</u> <u>Liquidated Damages</u>	<u>\$ 500</u> per day for delay of submittals
<u>Section 01330 - Submittal Procedures</u> <u>Liquidated Damages</u>	<u>\$1,500</u> per each additional submission of a Shop Drawing after the third submission.

<p style="text-align: center;"><b><u>CONTRACT ARTICLE 17.</u></b> <b><u>SUB-CONTRACTOR</u></b></p> <p>The <b>Contractor</b> shall not make subcontracts totaling an amount more than the percentage of the total <b>Contract</b> price indicated to the right.</p>	<p>Not to exceed <u>  40  </u> % of the <b>Contract</b> price</p>
<p style="text-align: center;"><b><u>CONTRACT ARTICLE 21.</u></b> <b><u>RETAINAGE</u></b></p> <p>The <b>Commissioner</b> shall deduct and retain until the substantial completion of the <b>Work</b> the percent value of the <b>Work</b> indicated to the right.</p>	<p><u>  5  </u> % of the value of the <b>Work</b></p>
<p style="text-align: center;"><b><u>CONTRACT ARTICLE 22.</u></b></p> <p style="text-align: center;"><b><u>(Per Directions Below)</u></b></p>	
<p style="text-align: center;"><b><u>CONTRACT ARTICLE 24.</u></b> <b><u>DEPOSIT GUARANTEE</u></b></p> <p>As security for the faithful performance of its obligations, the <b>Contractor</b>, upon filing its requisition for payment on <b>Substantial Completion</b>, shall deposit with the <b>Commissioner</b> a sum equal to the percentage of the <b>Contract</b> price indicated to the right.</p>	<p>1% of <b>Contract</b> price</p>
<p style="text-align: center;"><b><u>CONTRACT ARTICLE 24.</u></b> <b><u>PERIOD OF GUARANTEE</u></b></p> <p>Periods of maintenance and guarantee other than the period set forth in Article 24.1 are indicated to the right.</p>	<p>DS 02190 – Planting (24 months following Substantial Completion or plant replacement)</p> <p>DS 07111 – Bituminous Dampproofing (2 years following Substantial Completion)</p> <p>DS 07611 – Sheet Metal Roofing (3 years following Substantial Completion)</p> <p>DS 07621 – Gutters and Downspouts (2 years following Substantial Completion)</p> <p>DS 07900 – Caulking and Sealants (2 years following Substantial Completion)</p>

**CONTRACT ARTICLE 74.**  
**STATEMENT OF WORK**

The **Contractor** shall furnish all labor and materials and perform all **Work** in strict accordance with the **Contract Drawings, Specifications, and all Addenda** thereto.

**CONTRACT ARTICLE 75.**  
**COMPENSATION TO BE PAID TO CONTRACTOR**

The **City** shall pay and the **Contractor** shall accept in full consideration for the performance of the **Contract**, subject to additions and deductions as provided herein, the total sum **shown in the column to the right**, this said sum being the amount at which the **Contract** was awarded to the **Contractor** at a public letting thereof, based upon the **Contractor's** bid for the **Contract**.

Amount for which the **Contract** was awarded:

\$ \_\_\_\_\_

[Agency: If the Bid Price, or any portion thereof, is based on unit prices, insert the words "Not to Exceed" before the amount.]

**(GENERAL CONDITIONS RELATING TO ARTICLE 22 -- INSURANCE)**

**PART II. TYPES OF INSURANCE, MINIMUM LIMITS AND SPECIAL CONDITIONS**

**Note: All certificate(s) of insurance submitted pursuant to Contract Article 22.3.3 must be accompanied by a Certification by Broker consistent with Part III below and include the following information:**

- For each insurance policy, the name and NAIC number of issuing company, number of policy, and effective dates;
- Policy limits consistent with the requirements listed below;
- Additional insureds or loss payees consistent with the requirements listed below; and
- The number assigned to the Contract by the City (in the “Description of Operations” field).

**Insurance indicated by a blackened box (■) or by X in a □ to left will be required under this contract**

Types of Insurance (per Article 22 in its entirety, including listed paragraph)	Minimum Limits and Special Conditions
<p>■ Commercial General Liability      Art. 22.1.1</p>	<p>The minimum limits shall be <u>\$3,000,000</u> per occurrence and <u>\$6,000,000</u> per project aggregate applicable to this Contract unless the Work requires a permit from the Department of Buildings and greater limits of Commercial General Liability Insurance are required pursuant to 1 RCNY section 101-08.</p> <p>Additional Insureds:</p> <p>1. City of New York, including its officials and employees, with coverage at least as broad as ISO Forms CG 20 10 and CG 20 37, and</p> <p>2. All person(s) or organization(s), if any, that Article 22.1.1(b) of the <b>Contract</b> requires to be named as Additional Insured(s), with coverage at least as broad as ISO Form CG 20 26. The Additional Insured endorsement shall either specify the entity's name, if known, or the entity's title (e.g., Project Manager).</p> <p>3. <i>[Agency: If appropriate, insert names of other entities to be covered as Additional Insureds.]</i></p>
<p>■ Workers’ Compensation      Art. 22.1.2</p> <p>■ Disability Benefits Insurance      Art. 22.1.2</p>	<p>Workers’ Compensation, Employers’ Liability, and Disability Benefits Insurance: Statutory per New York State law without regard to jurisdiction.</p>



<input checked="" type="checkbox"/> Contractors Pollution Liability      Art. 22.1.6	<p>\$ <u>1,000,000</u> _____ per occurrence</p> <p>\$ <u>2,000,000</u> _____ aggregate</p> <p>Additional Insureds:</p> <p>1. City of New York, including its officials and employees, and</p> <p>2. _____</p> <p>3. _____</p>
<input type="checkbox"/> Marine Protection and Indemnity      Art. 22.1.7(a)	<p>\$ _____ per occurrence</p> <p>\$ _____ aggregate</p> <p>Additional Insureds:</p> <p>1. City of New York, including its officials and employees, and</p> <p>2. _____</p> <p>3. _____</p>
<input type="checkbox"/> Hull and Machinery Insurance      Art. 22.1.7(b)	<p>\$ _____ per occurrence</p> <p>\$ _____ aggregate</p> <p>Additional Insureds:</p> <p>1. City of New York, including its officials and employees, and</p> <p>2. _____</p> <p>3. _____</p>
<input type="checkbox"/> Marine Pollution Liability      Art. 22.1.7(c)	<p>\$ _____ each occurrence</p> <p>Additional Insureds:</p> <p>1. City of New York, including its officials and employees, and</p> <p>2. _____</p> <p>3. _____</p>

<p>[OTHER] Art. 22.1.8</p> <p><input type="checkbox"/> _____</p>	<p><i>[If other type(s) of insurance need to be required under the <b>Contract</b>, the Contracting Agency should (a) check the box and fill in the type of insurance in left-hand column, and (b) in this right-hand column, specify appropriate limit(s) and appropriate Named Insured and Additional Insured(s). Note that if Railroad Protective Liability Insurance is required, the appropriate Named Insured is the owner of the railroad and there are no additional insureds.]</i></p>
<p>[OTHER] Art. 22.1.8</p> <p><input type="checkbox"/> _____</p>	<p><i>[See directly above.]</i></p>

**SCHEDULE A**

**GENERAL CONDITIONS TO CONSTRUCTION CONTRACT**

**PART III. BROKER'S CERTIFICATION**

**CERTIFICATES OF INSURANCE**

**Instructions to New York City Agencies, Departments, and Offices**

All certificates of insurance (except certificates of insurance solely evidencing Workers' Compensation Insurance, Employer's Liability Insurance, and/or Disability Benefits Insurance) must be accompanied by one of the following:

- (1) the Certification by Insurance Broker or Agent on the following page setting forth the required information and signatures;

-- OR --

- (2) copies of all policies as certified by an authorized representative of the issuing insurance carrier that are referenced in such certificate of insurance. If any policy is not available at the time of submission, certified binders may be submitted until such time as the policy is available, at which time a certified copy of the policy shall be submitted.



**SCHEDULE A**

**CITY OF NEW YORK  
CERTIFICATION BY INSURANCE BROKER OR AGENT**

The undersigned insurance broker or agent represents to the City of New York that the attached Certificate of Insurance is accurate in all material respects.

\_\_\_\_\_  
[Name of broker or agent (typewritten)]

\_\_\_\_\_  
[Address of broker or agent (typewritten)]

\_\_\_\_\_  
[Email address of broker or agent (typewritten)]

\_\_\_\_\_  
[Phone number/Fax number of broker or agent (typewritten)]

\_\_\_\_\_  
[Signature of authorized official, broker, or agent]

\_\_\_\_\_  
[Name and title of authorized official, broker, or agent (typewritten)]

State of .....)

) ss.:

County of .....)

Sworn to before me this \_\_\_\_ day of \_\_\_\_\_ 20\_\_

\_\_\_\_\_  
NOTARY PUBLIC FOR THE STATE OF \_\_\_\_\_

**SCHEDULE A**  
**(GENERAL CONDITIONS TO CONSTRUCTION CONTRACT)**

**PART IV. ADDRESS OF COMMISSIONER**

Wherever reference is made in Article 7 or Article 22 to documents to be sent to the **Commissioner** (e.g., notices, filings, or submissions), such documents shall be sent to the address set forth below or, in the absence of such address, to the **Commissioner's** address as provided elsewhere in this **Contract**.

[**Note to Contracting Agency:** Fill in Risk Manager, ACCO or other person responsible for insurance]

NYC Department of Environmental Protection  
Office of the Agency Chief Contracting Officer  
59-17 Junction Blvd., 17<sup>th</sup> Floor Bid Room  
Flushing NY, 11373  
Email: [insurance@dep.nyc.gov](mailto:insurance@dep.nyc.gov)

**SCHEDULE A**

**GENERAL CONDITIONS TO CONSTRUCTION CONTRACT**  
**(INCLUDING GENERAL CONDITIONS RELATING TO ARTICLE 22 -- INSURANCE)**

**CONTRACT CRO-557H**

**PART I. REQUIRED INFORMATION**

<b><u>INFORMATION FOR BIDDERS</u></b> <b><u>BID BOND</u></b>	N/A
The <b>Contractor</b> shall obtain a bid bond in the amount indicated to the right.	
<b><u>INFORMATION FOR BIDDERS</u></b> <b><u>PERFORMANCE AND PAYMENT BONDS</u></b>	N/A
The <b>Contractor</b> shall obtain performance and payment bonds in the amount indicated to the right.	
<b><u>CONTRACT ARTICLE 14.</u></b> <b><u>DATE FOR SUBSTANTIAL COMPLETION</u></b>	730 consecutive calendar days
The <b>Contractor</b> shall substantially complete the <b>Work</b> in the number of calendar days indicated to the right.	
<b><u>CONTRACT ARTICLE 15.</u></b> <b><u>LIQUIDATED DAMAGES</u></b>	\$ 500 for each consecutive calendar day over substantial completion time
If the <b>Contractor</b> fails to substantially complete the <b>Work</b> within the time fixed for substantial completion plus authorized time extensions or if the <b>Contractor</b> , in the sole determination of the <b>Commissioner</b> , has abandoned the <b>Work</b> , the <b>Contractor</b> shall pay to the <b>City</b> the amount indicated to the right.	
Section 01321 – Progress Schedule <u>Liquidated Damages</u>	\$ 500 per day for delay of submittals
Section 01330 - Submittal Procedures <u>Liquidated Damages</u>	\$1,500 per each additional submission of a Shop Drawing after the third submission.

<p style="text-align: center;"><b><u>CONTRACT ARTICLE 17.</u></b> <b><u>SUB-CONTRACTOR</u></b></p> <p>The <b>Contractor</b> shall not make subcontracts totaling an amount more than the percentage of the total <b>Contract</b> price indicated to the right.</p>	<p>Not to exceed <u>  40  </u> % of the <b>Contract</b> price</p>
<p style="text-align: center;"><b><u>CONTRACT ARTICLE 21.</u></b> <b><u>RETAINAGE</u></b></p> <p>The <b>Commissioner</b> shall deduct and retain until the substantial completion of the <b>Work</b> the percent value of the <b>Work</b> indicated to the right.</p>	<p><u>  5  </u> % of the value of the <b>Work</b></p>
<p style="text-align: center;"><b><u>CONTRACT ARTICLE 22.</u></b></p> <p style="text-align: center;"><b><u>(Per Directions Below)</u></b></p>	
<p style="text-align: center;"><b><u>CONTRACT ARTICLE 24.</u></b> <b><u>DEPOSIT GUARANTEE</u></b></p> <p>As security for the faithful performance of its obligations, the <b>Contractor</b>, upon filing its requisition for payment on <b>Substantial Completion</b>, shall deposit with the <b>Commissioner</b> a sum equal to the percentage of the <b>Contract</b> price indicated to the right.</p>	<p>1% of <b>Contract</b> price</p>
<p style="text-align: center;"><b><u>CONTRACT ARTICLE 24.</u></b> <b><u>PERIOD OF GUARANTEE</u></b></p> <p>Periods of maintenance and guarantee other than the period set forth in Article 24.1 are indicated to the right.</p>	
<p style="text-align: center;"><b><u>CONTRACT ARTICLE 74.</u></b> <b><u>STATEMENT OF WORK</u></b></p> <p>The <b>Contractor</b> shall furnish all labor and materials and perform all <b>Work</b> in strict accordance with the <b>Contract Drawings, Specifications, and all Addenda</b> thereto.</p>	

**CONTRACT ARTICLE 75.**  
**COMPENSATION TO BE PAID TO CONTRACTOR**

The **City** shall pay and the **Contractor** shall accept in full consideration for the performance of the **Contract**, subject to additions and deductions as provided herein, the total sum **shown in the column to the right**, this said sum being the amount at which the **Contract** was awarded to the **Contractor** at a public letting thereof, based upon the **Contractor's** bid for the **Contract**.

Amount for which the **Contract** was awarded:

\$ \_\_\_\_\_  
[Agency: If the Bid Price, or any portion thereof, is based on unit prices, insert the words "Not to Exceed" before the amount.]

**(GENERAL CONDITIONS RELATING TO ARTICLE 22 -- INSURANCE)**

**PART II. TYPES OF INSURANCE, MINIMUM LIMITS AND SPECIAL CONDITIONS**

**Note:** All certificate(s) of insurance submitted pursuant to Contract Article 22.3.3 must be accompanied by a Certification by Broker consistent with Part III below and include the following information:

- For each insurance policy, the name and NAIC number of issuing company, number of policy, and effective dates;
- Policy limits consistent with the requirements listed below;
- Additional insureds or loss payees consistent with the requirements listed below; and
- The number assigned to the Contract by the City (in the “Description of Operations” field).

Insurance indicated by a blackened box (■) or by X in a □ to left will be required under this contract

Types of Insurance (per Article 22 in its entirety, including listed paragraph)	Minimum Limits and Special Conditions
<p>■ Commercial General Liability      Art. 22.1.1</p>	<p>The minimum limits shall be <u>\$1,000,000</u> per occurrence and <u>\$2,000,000</u> per project aggregate applicable to this Contract unless the Work requires a permit from the Department of Buildings and greater limits of Commercial General Liability Insurance are required pursuant to 1 RCNY section 101-08.</p> <p>Additional Insureds:</p> <p>1. City of New York, including its officials and employees, with coverage at least as broad as ISO Forms CG 20 10 and CG 20 37, and</p> <p>2. All person(s) or organization(s), if any, that Article 22.1.1(b) of the <b>Contract</b> requires to be named as Additional Insured(s), with coverage at least as broad as ISO Form CG 20 26. The Additional Insured endorsement shall either specify the entity's name, if known, or the entity's title (e.g., Project Manager).</p> <p>3. <i>[Agency: If appropriate, insert names of other entities to be covered as Additional Insureds.]</i></p>
<p>■ Workers' Compensation      Art. 22.1.2</p> <p>■ Disability Benefits Insurance      Art. 22.1.2</p>	<p>Workers' Compensation, Employers' Liability, and Disability Benefits Insurance: Statutory per New York State law without regard to jurisdiction.</p>

<p><input checked="" type="checkbox"/> Employers' Liability Art. 22.1.2</p> <p><input type="checkbox"/> Jones Act Art. 22.1.3</p> <p><input type="checkbox"/> U.S. Longshoremen's and Harbor Workers Compensation Act Art. 22.1.3</p>	<p><b>Note:</b> The following forms are acceptable: (1) New York State Workers' Compensation Board Form No. C-105.2, (2) State Insurance Fund Form No. U-26.3, (3) New York State Workers' Compensation Board Form No. DB-120.1 and (3) Request for WC/DB Exemption Form No. CE-200. The City will not accept an ACORD form as proof of Workers' Compensation or Disability Insurance.</p> <p>Jones Act and U.S. Longshoremen's and Harbor Workers' Compensation Act: Statutory per U.S. law.</p>
<p><input type="checkbox"/> Builders Risk Art. 22.1.4</p>	<p>100 % of total value of <b>Work</b></p> <p><b>Contractor</b> the Named Insured; the <b>City</b> both an Additional Insured and one of the loss payees as its interests may appear.</p> <p>If the <b>Work</b> does not involve construction of a new building or gut renovation work, the <b>Contractor</b> may provide an installation floater in lieu of Builders Risk insurance.</p> <p>Note: Builders Risk Insurance may terminate upon <b>Substantial Completion</b> of the <b>Work</b> in its entirety.</p>
<p><input checked="" type="checkbox"/> Commercial Auto Liability Art. 22.1.5</p>	<p><u>\$1,000,000</u> per accident combined single limit</p> <p>If vehicles are used for transporting hazardous materials, the <b>Contractor</b> shall provide pollution liability broadened coverage for covered vehicles (endorsement CA 99 48) as well as proof of MCS 90</p>

<input type="checkbox"/> Contractors Pollution Liability      Art. 22.1.6	<p>\$ _____ per occurrence</p> <p>\$ _____ aggregate</p> <p>Additional Insureds:</p> <p>1. City of New York, including its officials and employees, and</p> <p>2. _____</p> <p>3. _____</p>
<input type="checkbox"/> Marine Protection and Indemnity      Art. 22.1.7(a)	<p>\$ _____ per occurrence</p> <p>\$ _____ aggregate</p> <p>Additional Insureds:</p> <p>1. City of New York, including its officials and employees, and</p> <p>2. _____</p> <p>3. _____</p>
<input type="checkbox"/> Hull and Machinery Insurance      Art. 22.1.7(b)	<p>\$ _____ per occurrence</p> <p>\$ _____ aggregate</p> <p>Additional Insureds:</p> <p>1. City of New York, including its officials and employees, and</p> <p>2. _____</p> <p>3. _____</p>
<input type="checkbox"/> Marine Pollution Liability      Art. 22.1.7(c)	<p>\$ _____ each occurrence</p> <p>Additional Insureds:</p> <p>1. City of New York, including its officials and employees, and</p> <p>2. _____</p> <p>3. _____</p>



<p>[OTHER] Art. 22.1.8</p> <p><input type="checkbox"/> _____</p>	<p><i>[If other type(s) of insurance need to be required under the <b>Contract</b>, the Contracting Agency should (a) check the box and fill in the type of insurance in left-hand column, and (b) in this right-hand column, specify appropriate limit(s) and appropriate Named Insured and Additional Insured(s). Note that if Railroad Protective Liability Insurance is required, the appropriate Named Insured is the owner of the railroad and there are no additional insureds.]</i></p>
<p>[OTHER] Art. 22.1.8</p> <p><input type="checkbox"/> _____</p>	<p><i>[See directly above.]</i></p>

**SCHEDULE A**

**GENERAL CONDITIONS TO CONSTRUCTION CONTRACT**

**PART III. BROKER'S CERTIFICATION**

**CERTIFICATES OF INSURANCE**

**Instructions to New York City Agencies, Departments, and Offices**

All certificates of insurance (except certificates of insurance solely evidencing Workers' Compensation Insurance, Employer's Liability Insurance, and/or Disability Benefits Insurance) must be accompanied by one of the following:

- (1) the Certification by Insurance Broker or Agent on the following page setting forth the required information and signatures;

-- OR --

- (2) copies of all policies as certified by an authorized representative of the issuing insurance carrier that are referenced in such certificate of insurance. If any policy is not available at the time of submission, certified binders may be submitted until such time as the policy is available, at which time a certified copy of the policy shall be submitted.

**SCHEDULE A**

**CITY OF NEW YORK  
CERTIFICATION BY INSURANCE BROKER OR AGENT**

The undersigned insurance broker or agent represents to the City of New York that the attached Certificate of Insurance is accurate in all material respects.

\_\_\_\_\_  
[Name of broker or agent (typewritten)]

\_\_\_\_\_  
[Address of broker or agent (typewritten)]

\_\_\_\_\_  
[Email address of broker or agent (typewritten)]

\_\_\_\_\_  
[Phone number/Fax number of broker or agent (typewritten)]

\_\_\_\_\_  
[Signature of authorized official, broker, or agent]

\_\_\_\_\_  
[Name and title of authorized official, broker, or agent (typewritten)]

State of .....)

) ss.:

County of .....)

Sworn to before me this \_\_\_\_ day of \_\_\_\_\_ 20\_\_

\_\_\_\_\_  
NOTARY PUBLIC FOR THE STATE OF \_\_\_\_\_

**SCHEDULE A**  
**(GENERAL CONDITIONS TO CONSTRUCTION CONTRACT)**

**PART IV. ADDRESS OF COMMISSIONER**

Wherever reference is made in Article 7 or Article 22 to documents to be sent to the **Commissioner** (e.g., notices, filings, or submissions), such documents shall be sent to the address set forth below or, in the absence of such address, to the **Commissioner's** address as provided elsewhere in this **Contract**.

[**Note to Contracting Agency:** Fill in Risk Manager, ACCO or other person responsible for insurance]

NYC Department of Environmental Protection  
Office of the Agency Chief Contracting Officer  
59-17 Junction Blvd., 17<sup>th</sup> Floor Bid Room  
Flushing NY, 11373  
Email: [insurance@dep.nyc.gov](mailto:insurance@dep.nyc.gov)

SCHEDULE A

GENERAL CONDITIONS TO CONSTRUCTION CONTRACT  
(INCLUDING GENERAL CONDITIONS RELATING TO ARTICLE 22 -- INSURANCE)

CONTRACT CRO-557P

PART I. REQUIRED INFORMATION

<u>INFORMATION FOR BIDDERS</u> <u>BID BOND</u>	N/A
<u>The Contractor shall obtain a bid bond in the amount indicated to the right.</u>	
<u>INFORMATION FOR BIDDERS</u> <u>PERFORMANCE AND PAYMENT BONDS</u>	N/A
<u>The Contractor shall obtain performance and payment bonds in the amount indicated to the right.</u>	
<u>CONTRACT ARTICLE 14.</u> <u>DATE FOR SUBSTANTIAL COMPLETION</u>	<u>730</u> consecutive calendar days
<u>The Contractor shall substantially complete the Work in the number of calendar days indicated to the right.</u>	
<u>CONTRACT ARTICLE 15.</u> <u>LIQUIDATED DAMAGES</u>	\$ <u>250</u> for each consecutive calendar day over substantial completion time
<u>If the Contractor fails to substantially complete the Work within the time fixed for substantial completion plus authorized time extensions or if the Contractor, in the sole determination of the Commissioner, has abandoned the Work, the Contractor shall pay to the City the amount indicated to the right.</u>	
<u>Section 01321 – Progress Schedule</u> <u>Liquidated Damages</u>	\$ <u>500</u> per day for delay of submittals
<u>Section 01330 - Submittal Procedures</u> <u>Liquidated Damages</u>	\$ <u>1,500</u> per each additional submission of a Shop Drawing after the third submission.

<p style="text-align: center;"><b><u>CONTRACT ARTICLE 17.</u></b> <b><u>SUB-CONTRACTOR</u></b></p> <p>The <b>Contractor</b> shall not make subcontracts totaling an amount more than the percentage of the total <b>Contract</b> price indicated to the right.</p>	<p>Not to exceed <u>  40  </u> % of the <b>Contract</b> price</p>
<p style="text-align: center;"><b><u>CONTRACT ARTICLE 21.</u></b> <b><u>RETAINAGE</u></b></p> <p>The <b>Commissioner</b> shall deduct and retain until the substantial completion of the <b>Work</b> the percent value of the <b>Work</b> indicated to the right.</p>	<p><u>  5  </u> % of the value of the <b>Work</b></p>
<p style="text-align: center;"><b><u>CONTRACT ARTICLE 22.</u></b></p> <p style="text-align: center;"><b><u>(Per Directions Below)</u></b></p>	
<p style="text-align: center;"><b><u>CONTRACT ARTICLE 24.</u></b> <b><u>DEPOSIT GUARANTEE</u></b></p> <p>As security for the faithful performance of its obligations, the <b>Contractor</b>, upon filing its requisition for payment on <b>Substantial Completion</b>, shall deposit with the <b>Commissioner</b> a sum equal to the percentage of the <b>Contract</b> price indicated to the right.</p>	<p>1% of <b>Contract</b> price</p>
<p style="text-align: center;"><b><u>CONTRACT ARTICLE 24.</u></b> <b><u>PERIOD OF GUARANTEE</u></b></p> <p>Periods of maintenance and guarantee other than the period set forth in Article 24.1 are indicated to the right.</p>	
<p style="text-align: center;"><b><u>CONTRACT ARTICLE 74.</u></b> <b><u>STATEMENT OF WORK</u></b></p> <p>The <b>Contractor</b> shall furnish all labor and materials and perform all <b>Work</b> in strict accordance with the <b>Contract Drawings, Specifications, and all Addenda</b> thereto.</p>	

**CONTRACT ARTICLE 75.**  
**COMPENSATION TO BE PAID TO CONTRACTOR**

The **City** shall pay and the **Contractor** shall accept in full consideration for the performance of the **Contract**, subject to additions and deductions as provided herein, the total sum **shown in the column to the right**, this said sum being the amount at which the **Contract** was awarded to the **Contractor** at a public letting thereof, based upon the **Contractor's** bid for the **Contract**.

Amount for which the **Contract** was awarded:

\$ \_\_\_\_\_  
[Agency: If the Bid Price, or any portion thereof, is based on unit prices, insert the words "Not to Exceed" before the amount.]

**(GENERAL CONDITIONS RELATING TO ARTICLE 22 -- INSURANCE)**

**PART II. TYPES OF INSURANCE, MINIMUM LIMITS AND SPECIAL CONDITIONS**

**Note:** All certificate(s) of insurance submitted pursuant to Contract Article 22.3.3 must be accompanied by a Certification by Broker consistent with Part III below and include the following information:

- For each insurance policy, the name and NAIC number of issuing company, number of policy, and effective dates;
- Policy limits consistent with the requirements listed below;
- Additional insureds or loss payees consistent with the requirements listed below; and
- The number assigned to the Contract by the City (in the “Description of Operations” field).

Insurance indicated by a blackened box (■) or by X in a □ to left will be required under this contract

Types of Insurance (per Article 22 in its entirety, including listed paragraph)	Minimum Limits and Special Conditions
<p>■ Commercial General Liability      Art. 22.1.1</p>	<p>The minimum limits shall be <u>\$1,000,000</u> per occurrence and <u>\$2,000,000</u> per project aggregate applicable to this Contract unless the Work requires a permit from the Department of Buildings and greater limits of Commercial General Liability Insurance are required pursuant to 1 RCNY section 101-08.</p> <p>Additional Insureds:</p> <p>1. City of New York, including its officials and employees, with coverage at least as broad as ISO Forms CG 20 10 and CG 20 37, and</p> <p>2. All person(s) or organization(s), if any, that Article 22.1.1(b) of the <b>Contract</b> requires to be named as Additional Insured(s), with coverage at least as broad as ISO Form CG 20 26. The Additional Insured endorsement shall either specify the entity's name, if known, or the entity's title (e.g., Project Manager).</p> <p>3. <i>[Agency: If appropriate, insert names of other entities to be covered as Additional Insureds.]</i></p>
<p>■ Workers’ Compensation      Art. 22.1.2</p> <p>■ Disability Benefits Insurance      Art. 22.1.2</p>	<p>Workers’ Compensation, Employers’ Liability, and Disability Benefits Insurance: Statutory per New York State law without regard to jurisdiction.</p>



<p><input checked="" type="checkbox"/> Employers' Liability Art. 22.1.2</p> <p><input type="checkbox"/> Jones Act Art. 22.1.3</p> <p><input type="checkbox"/> U.S. Longshoremen's and Harbor Workers Compensation Act Art. 22.1.3</p>	<p><b>Note:</b> The following forms are acceptable: (1) New York State Workers' Compensation Board Form No. C-105.2, (2) State Insurance Fund Form No. U-26.3, (3) New York State Workers' Compensation Board Form No. DB-120.1 and (3) Request for WC/DB Exemption Form No. CE-200. The City will not accept an ACORD form as proof of Workers' Compensation or Disability Insurance.</p> <p>Jones Act and U.S. Longshoremen's and Harbor Workers' Compensation Act: Statutory per U.S. law.</p>
<p><input type="checkbox"/> Builders Risk Art. 22.1.4</p>	<p>100 % of total value of <b>Work</b></p> <p><b>Contractor</b> the Named Insured; the <b>City</b> both an Additional Insured and one of the loss payees as its interests may appear.</p> <p>If the <b>Work</b> does not involve construction of a new building or gut renovation work, the <b>Contractor</b> may provide an installation floater in lieu of Builders Risk insurance.</p> <p>Note: Builders Risk Insurance may terminate upon <b>Substantial Completion</b> of the <b>Work</b> in its entirety.</p>
<p><input checked="" type="checkbox"/> Commercial Auto Liability Art. 22.1.5</p>	<p><u>\$1,000,000</u> per accident combined single limit</p> <p>If vehicles are used for transporting hazardous materials, the <b>Contractor</b> shall provide pollution liability broadened coverage for covered vehicles (endorsement CA 99 48) as well as proof of MCS 90</p>

<input type="checkbox"/> Contractors Pollution Liability      Art. 22.1.6	\$ _____ per occurrence  \$ _____ aggregate  Additional Insureds: 1. City of New York, including its officials and employees, and  2. _____  3. _____
<input type="checkbox"/> Marine Protection and Indemnity      Art. 22.1.7(a)	\$ _____ per occurrence  \$ _____ aggregate  Additional Insureds: 1. City of New York, including its officials and employees, and  2. _____  3. _____
<input type="checkbox"/> Hull and Machinery Insurance      Art. 22.1.7(b)	\$ _____ per occurrence  \$ _____ aggregate  Additional Insureds: 1. City of New York, including its officials and employees, and  2. _____  3. _____
<input type="checkbox"/> Marine Pollution Liability      Art. 22.1.7(c)	\$ _____ each occurrence  Additional Insureds: 1. City of New York, including its officials and employees, and  2. _____  3. _____

<p>[OTHER] Art. 22.1.8</p> <p><input type="checkbox"/> _____</p>	<p><i>[If other type(s) of insurance need to be required under the <b>Contract</b>, the Contracting Agency should (a) check the box and fill in the type of insurance in left-hand column, and (b) in this right-hand column, specify appropriate limit(s) and appropriate Named Insured and Additional Insured(s). Note that if Railroad Protective Liability Insurance is required, the appropriate Named Insured is the owner of the railroad and there are no additional insureds.]</i></p>
<p>[OTHER] Art. 22.1.8</p> <p><input type="checkbox"/> _____</p>	<p><i>[See directly above.]</i></p>

**SCHEDULE A**

**GENERAL CONDITIONS TO CONSTRUCTION CONTRACT**

**PART III. BROKER'S CERTIFICATION**

**CERTIFICATES OF INSURANCE**

**Instructions to New York City Agencies, Departments, and Offices**

All certificates of insurance (except certificates of insurance solely evidencing Workers' Compensation Insurance, Employer's Liability Insurance, and/or Disability Benefits Insurance) must be accompanied by one of the following:

- (1) the Certification by Insurance Broker or Agent on the following page setting forth the required information and signatures;

-- OR --

- (2) copies of all policies as certified by an authorized representative of the issuing insurance carrier that are referenced in such certificate of insurance. If any policy is not available at the time of submission, certified binders may be submitted until such time as the policy is available, at which time a certified copy of the policy shall be submitted.

**SCHEDULE A**

**CITY OF NEW YORK  
CERTIFICATION BY INSURANCE BROKER OR AGENT**

The undersigned insurance broker or agent represents to the City of New York that the attached Certificate of Insurance is accurate in all material respects.

\_\_\_\_\_  
[Name of broker or agent (typewritten)]

\_\_\_\_\_  
[Address of broker or agent (typewritten)]

\_\_\_\_\_  
[Email address of broker or agent (typewritten)]

\_\_\_\_\_  
[Phone number/Fax number of broker or agent (typewritten)]

\_\_\_\_\_  
[Signature of authorized official, broker, or agent]

\_\_\_\_\_  
[Name and title of authorized official, broker, or agent (typewritten)]

State of .....)

) ss.:

County of .....)

Sworn to before me this \_\_\_\_ day of \_\_\_\_\_ 20\_\_

\_\_\_\_\_  
NOTARY PUBLIC FOR THE STATE OF \_\_\_\_\_

**SCHEDULE A**  
**(GENERAL CONDITIONS TO CONSTRUCTION CONTRACT)**

**PART IV. ADDRESS OF COMMISSIONER**

Wherever reference is made in Article 7 or Article 22 to documents to be sent to the **Commissioner** (e.g., notices, filings, or submissions), such documents shall be sent to the address set forth below or, in the absence of such address, to the **Commissioner's** address as provided elsewhere in this **Contract**.

[**Note to Contracting Agency:** Fill in Risk Manager, ACCO or other person responsible for insurance]

NYC Department of Environmental Protection  
Office of the Agency Chief Contracting Officer  
59-17 Junction Blvd., 17<sup>th</sup> Floor Bid Room  
Flushing NY, 11373  
Email: [insurance@dep.nyc.gov](mailto:insurance@dep.nyc.gov)

SCHEDULE A

GENERAL CONDITIONS TO CONSTRUCTION CONTRACT  
(INCLUDING GENERAL CONDITIONS RELATING TO ARTICLE 22 -- INSURANCE)

CONTRACT CRO-557E

PART I. REQUIRED INFORMATION

<p style="text-align: center;"><u>INFORMATION FOR BIDDERS</u> <u>BID BOND</u></p> <p>The <b>Contractor</b> shall obtain a bid bond in the amount indicated to the right.</p>	<p style="text-align: center;">5 % of Bid</p>
<p style="text-align: center;"><u>INFORMATION FOR BIDDERS</u> <u>PERFORMANCE AND PAYMENT BONDS</u></p> <p>The <b>Contractor</b> shall obtain performance and payment bonds in the amount indicated to the right.</p>	<p style="text-align: center;">100 % of Bid</p>
<p style="text-align: center;"><u>CONTRACT ARTICLE 14.</u> <u>DATE FOR SUBSTANTIAL COMPLETION</u></p> <p>The <b>Contractor</b> shall substantially complete the <b>Work</b> in the number of calendar days indicated to the right.</p>	<p style="text-align: center;">730 consecutive calendar days</p>
<p style="text-align: center;"><u>CONTRACT ARTICLE 15.</u> <u>LIQUIDATED DAMAGES</u></p> <p>If the <b>Contractor</b> fails to substantially complete the <b>Work</b> within the time fixed for substantial completion plus authorized time extensions or if the <b>Contractor</b>, in the sole determination of the <b>Commissioner</b>, has abandoned the <b>Work</b>, the <b>Contractor</b> shall pay to the <b>City</b> the amount indicated to the right.</p>	<p style="text-align: center;">\$ 500 for each consecutive calendar day over substantial completion time</p>
<p>Section 01321 – Progress Schedule <u>Liquidated Damages</u></p>	<p style="text-align: center;">\$ 500 per day for delay of submittals</p>
<p>Section 01330 - Submittal Procedures <u>Liquidated Damages</u></p>	<p style="text-align: center;">\$1,500 per each additional submission of a Shop Drawing after the third submission.</p>

<p style="text-align: center;"><b><u>CONTRACT ARTICLE 17.</u></b> <b><u>SUB-CONTRACTOR</u></b></p> <p>The <b>Contractor</b> shall not make subcontracts totaling an amount more than the percentage of the total <b>Contract</b> price indicated to the right.</p>	<p>Not to exceed <u>  40  </u> % of the <b>Contract</b> price</p>
<p style="text-align: center;"><b><u>CONTRACT ARTICLE 21.</u></b> <b><u>RETAINAGE</u></b></p> <p>The <b>Commissioner</b> shall deduct and retain until the substantial completion of the <b>Work</b> the percent value of the <b>Work</b> indicated to the right.</p>	<p><u>  5  </u> % of the value of the <b>Work</b></p>
<p style="text-align: center;"><b><u>CONTRACT ARTICLE 22.</u></b></p> <p style="text-align: center;"><b><u>(Per Directions Below)</u></b></p>	
<p style="text-align: center;"><b><u>CONTRACT ARTICLE 24.</u></b> <b><u>DEPOSIT GUARANTEE</u></b></p> <p>As security for the faithful performance of its obligations, the <b>Contractor</b>, upon filing its requisition for payment on <b>Substantial Completion</b>, shall deposit with the <b>Commissioner</b> a sum equal to the percentage of the <b>Contract</b> price indicated to the right.</p>	<p>1% of <b>Contract</b> price</p>
<p style="text-align: center;"><b><u>CONTRACT ARTICLE 24.</u></b> <b><u>PERIOD OF GUARANTEE</u></b></p> <p>Periods of maintenance and guarantee other than the period set forth in Article 24.1 are indicated to the right.</p>	
<p style="text-align: center;"><b><u>CONTRACT ARTICLE 74.</u></b> <b><u>STATEMENT OF WORK</u></b></p> <p>The <b>Contractor</b> shall furnish all labor and materials and perform all <b>Work</b> in strict accordance with the <b>Contract Drawings, Specifications, and all Addenda</b> thereto.</p>	
<p style="text-align: center;"><b><u>CONTRACT ARTICLE 75.</u></b> <b><u>COMPENSATION TO BE PAID TO CONTRACTOR</u></b></p>	<p>Amount for which the <b>Contract</b> was awarded:</p>



The **City** shall pay and the **Contractor** shall accept in full consideration for the performance of the **Contract**, subject to additions and deductions as provided herein, the total sum **shown in the column to the right**, this said sum being the amount at which the **Contract** was awarded to the **Contractor** at a public letting thereof, based upon the **Contractor's** bid for the **Contract**.

\$ \_\_\_\_\_  
[Agency: If the Bid Price, or any portion thereof, is based on unit prices, insert the words “Not to Exceed” before the amount.]

**(GENERAL CONDITIONS RELATING TO ARTICLE 22 -- INSURANCE)**

**PART II. TYPES OF INSURANCE, MINIMUM LIMITS AND SPECIAL CONDITIONS**

**Note:** All certificate(s) of insurance submitted pursuant to Contract Article 22.3.3 must be accompanied by a Certification by Broker consistent with Part III below and include the following information:

- For each insurance policy, the name and NAIC number of issuing company, number of policy, and effective dates;
- Policy limits consistent with the requirements listed below;
- Additional insureds or loss payees consistent with the requirements listed below; and
- The number assigned to the Contract by the City (in the “Description of Operations” field).

Insurance indicated by a blackened box (■) or by X in a □ to left will be required under this contract

Types of Insurance (per Article 22 in its entirety, including listed paragraph)	Minimum Limits and Special Conditions
<p>■ Commercial General Liability      Art. 22.1.1</p>	<p>The minimum limits shall be <u>\$1,000,000</u> per occurrence and <u>\$2,000,000</u> per project aggregate applicable to this Contract unless the Work requires a permit from the Department of Buildings and greater limits of Commercial General Liability Insurance are required pursuant to 1 RCNY section 101-08.</p> <p>Additional Insureds:</p> <p>1. City of New York, including its officials and employees, with coverage at least as broad as ISO Forms CG 20 10 and CG 20 37, and</p> <p>2. All person(s) or organization(s), if any, that Article 22.1.1(b) of the <b>Contract</b> requires to be named as Additional Insured(s), with coverage at least as broad as ISO Form CG 20 26. The Additional Insured endorsement shall either specify the entity's name, if known, or the entity's title (e.g., Project Manager).</p> <p>3. <i>[Agency: If appropriate, insert names of other entities to be covered as Additional Insureds.]</i></p>
<p>■ Workers' Compensation      Art. 22.1.2</p> <p>■ Disability Benefits Insurance      Art. 22.1.2</p>	<p>Workers' Compensation, Employers' Liability, and Disability Benefits Insurance: Statutory per New York State law without regard to jurisdiction.</p>

<p><input checked="" type="checkbox"/> Employers' Liability Art. 22.1.2</p> <p><input type="checkbox"/> Jones Act Art. 22.1.3</p> <p><input type="checkbox"/> U.S. Longshoremen's and Harbor Workers Compensation Act Art. 22.1.3</p>	<p><b>Note:</b> The following forms are acceptable: (1) New York State Workers' Compensation Board Form No. C-105.2, (2) State Insurance Fund Form No. U-26.3, (3) New York State Workers' Compensation Board Form No. DB-120.1 and (3) Request for WC/DB Exemption Form No. CE-200. The City will not accept an ACORD form as proof of Workers' Compensation or Disability Insurance.</p> <p>Jones Act and U.S. Longshoremen's and Harbor Workers' Compensation Act: Statutory per U.S. law.</p>
<p><input type="checkbox"/> Builders Risk Art. 22.1.4</p>	<p>100 % of total value of <b>Work</b></p> <p><b>Contractor</b> the Named Insured; the <b>City</b> both an Additional Insured and one of the loss payees as its interests may appear.</p> <p>If the <b>Work</b> does not involve construction of a new building or gut renovation work, the <b>Contractor</b> may provide an installation floater in lieu of Builders Risk insurance.</p> <p>Note: Builders Risk Insurance may terminate upon <b>Substantial Completion</b> of the <b>Work</b> in its entirety.</p>
<p><input checked="" type="checkbox"/> Commercial Auto Liability Art. 22.1.5</p>	<p><u>\$1,000,000</u> per accident combined single limit</p> <p>If vehicles are used for transporting hazardous materials, the <b>Contractor</b> shall provide pollution liability broadened coverage for covered vehicles (endorsement CA 99 48) as well as proof of MCS 90</p>

<input type="checkbox"/> Contractors Pollution Liability      Art. 22.1.6	\$ _____ per occurrence  \$ _____ aggregate  Additional Insureds: 1. City of New York, including its officials and employees, and  2. _____  3. _____
<input type="checkbox"/> Marine Protection and Indemnity      Art. 22.1.7(a)	\$ _____ per occurrence  \$ _____ aggregate  Additional Insureds: 1. City of New York, including its officials and employees, and  2. _____  3. _____
<input type="checkbox"/> Hull and Machinery Insurance      Art. 22.1.7(b)	\$ _____ per occurrence  \$ _____ aggregate  Additional Insureds: 1. City of New York, including its officials and employees, and  2. _____  3. _____
<input type="checkbox"/> Marine Pollution Liability      Art. 22.1.7(c)	\$ _____ each occurrence  Additional Insureds: 1. City of New York, including its officials and employees, and  2. _____  3. _____

<p>[OTHER] Art. 22.1.8</p> <p><input type="checkbox"/> _____</p>	<p><i>[If other type(s) of insurance need to be required under the <b>Contract</b>, the Contracting Agency should (a) check the box and fill in the type of insurance in left-hand column, and (b) in this right-hand column, specify appropriate limit(s) and appropriate Named Insured and Additional Insured(s). Note that if Railroad Protective Liability Insurance is required, the appropriate Named Insured is the owner of the railroad and there are no additional insureds.]</i></p>
<p>[OTHER] Art. 22.1.8</p> <p><input type="checkbox"/> _____</p>	<p><i>[See directly above.]</i></p>

**SCHEDULE A**

**GENERAL CONDITIONS TO CONSTRUCTION CONTRACT**

**PART III. BROKER'S CERTIFICATION**

**CERTIFICATES OF INSURANCE**

**Instructions to New York City Agencies, Departments, and Offices**

All certificates of insurance (except certificates of insurance solely evidencing Workers' Compensation Insurance, Employer's Liability Insurance, and/or Disability Benefits Insurance) must be accompanied by one of the following:

- (1) the Certification by Insurance Broker or Agent on the following page setting forth the required information and signatures;

-- OR --

- (2) copies of all policies as certified by an authorized representative of the issuing insurance carrier that are referenced in such certificate of insurance. If any policy is not available at the time of submission, certified binders may be submitted until such time as the policy is available, at which time a certified copy of the policy shall be submitted.

**SCHEDULE A**

**CITY OF NEW YORK**  
**CERTIFICATION BY INSURANCE BROKER OR AGENT**

The undersigned insurance broker or agent represents to the City of New York that the attached Certificate of Insurance is accurate in all material respects.

\_\_\_\_\_  
[Name of broker or agent (typewritten)]

\_\_\_\_\_  
[Address of broker or agent (typewritten)]

\_\_\_\_\_  
[Email address of broker or agent (typewritten)]

\_\_\_\_\_  
[Phone number/Fax number of broker or agent (typewritten)]

\_\_\_\_\_  
[Signature of authorized official, broker, or agent]

\_\_\_\_\_  
[Name and title of authorized official, broker, or agent (typewritten)]

State of .....)

) ss.:

County of .....)

Sworn to before me this \_\_\_\_ day of \_\_\_\_\_ 20\_\_

\_\_\_\_\_  
NOTARY PUBLIC FOR THE STATE OF \_\_\_\_\_

**SCHEDULE A**  
**(GENERAL CONDITIONS TO CONSTRUCTION CONTRACT)**

**PART IV. ADDRESS OF COMMISSIONER**

Wherever reference is made in Article 7 or Article 22 to documents to be sent to the **Commissioner** (e.g., notices, filings, or submissions), such documents shall be sent to the address set forth below or, in the absence of such address, to the **Commissioner's** address as provided elsewhere in this **Contract**.

[**Note to Contracting Agency:** Fill in Risk Manager, ACCO or other person responsible for insurance]

NYC Department of Environmental Protection  
Office of the Agency Chief Contracting Officer  
59-17 Junction Blvd., 17<sup>th</sup> Floor Bid Room  
Flushing NY, 11373  
Email: [insurance@dep.nyc.gov](mailto:insurance@dep.nyc.gov)



**SECTION 02105  
Soil Sampling and Analysis**

**PART 1 GENERAL**

**1.01 SECTION INCLUDES**

- A. The Contractor shall provide all labor, materials, tools, and equipment to perform all operations necessary to characterize, classify and determine the requirements for handling, reuse and disposal of all materials to be excavated.
- B. The primary method of characterizing soils shall be through in-situ sampling. No stockpiling of excavated material on-site or ex-situ sampling will be allowed without written approval from the Engineer.
- C. The following index of this Section is included for convenience:

<u>Article</u>	<u>Title</u>	<u>Page</u>
		02105-
PART 1	GENERAL .....	1
1.01	Section Includes .....	1
1.02	Payment.....	1
1.03	Related Sections.....	1
1.04	References.....	2
1.05	Definitions.....	2
1.06	Sampling Requirements .....	6
1.07	Submittals .....	7
1.08	Off-Site Reuse/Disposal Facility .....	11
1.09	Quality Assurance.....	12
1.10	Delivery, Storage And Handling.....	13
1.11	Project Conditions.....	16
PART 2	PRODUCTS (NOT USED) .....	17
PART 3	EXECUTION.....	17
3.01	Testing.....	17

**1.02 PAYMENT**

- A. Unless otherwise provided in the Detailed Specifications, no separate payment will be made for performing any Work required under this Section and the Contractor shall include all costs thereof in its lump sum price bid for the Contract.

**1.03 RELATED SECTIONS**

- A. General Specification 02240 - Dewatering

## GENERAL SPECIFICATION 02105 – SOIL SAMPLING AND ANALYSIS

---

- B. General Specification 02316 - Excavation
- C. General Specification 02317 - Backfilling
- D. General Specification 02371 - Dust, Soil Erosion and Sedimentation Control

### 1.04 REFERENCES

- A. EPA QA/G-4, Guidance on Systematic Planning Using the Data Quality Objectives Process, February 2006 or latest revision
- B. USEPA Office of Solid Waste, Test Methods for Evaluating Solid Wastes, Physical/Chemical Methods (SW-846), Third Edition, December 1996 with updates or latest revision
- C. NYSDEC regulations, 6 NYCRR Subpart 360-1, General Provisions, Solid Waste Management Facilities
- D. NYSDEC regulations, 6 NYCRR Part 371, Identification and Listing of Hazardous Wastes (40 CFR Part 261)
- E. NYSDEC regulations, 6 NYCRR Subpart 375, Environmental Remediation Programs
- F. American Society for Testing and Materials (ASTM) Standards:
  - 1. D422 - Method for Particle-Size Analysis of Soils.
  - 2. D1556 - Test Method for Density and Unit Weight of Soil in Place by the Sand-Cone Method
  - 3. D1557 - Test Methods for Laboratory Compaction Characteristics of Soil Using Modified Effort (56,000 ft-lbf/ft<sup>3</sup> (2,700 kN-m/m<sup>3</sup>))
  - 4. D6938 - Test Method for In-Place Density and Water Content of Soil and Soil-Aggregate by Nuclear Methods (Shallow Depth)
- G. DER-10, Technical Guidance for Site Investigation and Remediation, NYSDEC Division of Environmental Remediation
- H. Commissioner Policy CP-51 Soil Cleanup Guidance Policy, Issued 10/21/2010; Effective 12/03/2010, NYSDEC Division of Environmental Remediation

### 1.05 DEFINITIONS

- A. Analyte-free Water: Water containing less than the detection limits for volatile organics, pesticides, PCBs and inorganics. Compliance shall be verified either by the supplier or by an analytical laboratory.
- B. Backfill: Material to be excavated and proposed for reuse as backfill must meet the solid waste cessation requirements of 6NYCRR 360-1.15(b) for a Pre-

## GENERAL SPECIFICATION 02105 SOIL SAMPLING AND ANALYSIS

---

Determined BUD or 6 NYCRR 360.1.15(d) for a Case-Specific BUD. Backfill shall be non-hazardous and shall meet the requirements of General Specification 02317 – Backfilling.

- C. Composite Sample: Composite sampling is comprised of grab samples which are initially collected from within a grid area and then combined into a single sample. This sample is representative of the entire grid area from which the grab samples were collected.
- D. Excavated Material: All material regardless of its nature, except rock or boulders that have been excavated. Refer to General Specification 02316 – Excavation.
- E. Ex-situ Soil Sampling: Sampling of soil that has been excavated and stockpiled.
- F. Grab Sample: A single sample is collected at a particular time and place that represents the composition of the soil only at that time and place.
- G. In-situ Soil Sampling: Sampling of soil prior to excavation and most representative of undisturbed conditions.
- H. Pre-Determined Beneficial Use Determination (BUD) – NYSDEC allows soil to be reused on-site under a Pre-Determined BUD under the following conditions: 360-1.15(b)(7) uncontaminated soil which has been excavated as part of a construction project, and which is being used as a fill material, in place of soil native to the site of disposition; 360-1.15(b)(8) non-hazardous, contaminated soil which has been excavated as part of a construction project, other than a NYSDEC-approved or undertaken inactive hazardous waste disposal site remediation program, and which is used as backfill for the same excavation or excavations containing similar contaminants at the same site. Excess materials on these projects are subject to the requirements of Part 360. No *de minimus* quantity of solid waste or historic fill is allowed when reusing soils under both 360-1.15(b)(7) and 360-1.15(b)(8), with the exception of reuse in the same excavation. Refer to Article 1.06 for sampling requirements for uncontaminated soil and non-hazardous, contaminated soil, and Article 3.01 for a list of parameters to be analyzed for soils to be reused on-site, or soils to be reused or disposed off-site.
- I. Case-Specific Beneficial Use Determination (BUD): Under 6 NYCRR 360-1.15 (d), NYSDEC sets forth the requirements for petitioning NYSDEC to obtain a Case-Specific BUD, and the criteria for reviewing, granting, or denying of the BUD. For reuse of a solid waste to be determined a beneficial use, the petition must demonstrate the following:
  - 1. The use will not adversely affect human health and safety, the environment, or natural resources.
  - 2. The solid waste is an effective substitute for a commercial product or can be used beneficially in the manufacture of a commercial product.

## GENERAL SPECIFICATION 02105 – SOIL SAMPLING AND ANALYSIS

---

3. The essential nature of the use constitutes a legitimate reuse and not disposal.
- J. Waste Classification:
1. Regulated Solid Waste:
    - a. Hazardous Solid Waste: Material shall be considered a characteristic hazardous solid waste when it exhibits any of the following: ignitability, corrosivity, reactivity, or toxicity for Volatile Organic Compounds (VOCs), semi-VOCs (SVOCs), metals, pesticides, or herbicides, as defined in 6 NYCRR Part 371 or 40 CFR Section 261. Under New York State (NYS) regulations, a material that contains greater than 50 ppm of PCBs is considered a hazardous waste. The Environmental Protection Agency (EPA) considers greater than 50 ppm of PCB to be a PCB-contaminated waste under Toxic Substances Control Act (TSCA). All hazardous waste shall be considered unsuitable for reuse, and shall be disposed of at an approved permitted hazardous waste landfill.
    - b. Non-Hazardous Contaminated Waste:
      - 1) Industrial Waste: Non-hazardous contaminated waste includes industrial waste (i.e., solid waste generated by manufacturing or industrial processes). Such processes may include, but are not limited to the following: electric power generation; fertilizer/agricultural chemicals; inorganic chemicals; iron and steel manufacturing; organic chemicals; and all other materials as defined in 6 NYCRR Part 360. The forms of such wastes are exemplified by but not limited to: liquids such as acids, alkalis, caustics, leachate, petroleum (and its derivatives), and processes or treatment wastewaters; sludges which are semi-solid substances resulting from process or treatment operations or residues from storage or use of liquids; solidified chemicals, paints or pigments; and dredge spoil generated by manufacturing or industrial processes, foundry sand, and the end or by-products of incineration or other forms of combustion. Physical evidence that a soil contains industrial waste shall include visual identification of waste, chemical odors, vapor emission, and chemical staining. Evidence that soil is contaminated shall also include contaminant concentrations exceeding 6 NYCRR Part 375-6 Lower of Groundwater Protection and Residential Soil Cleanup Objectives (SCOs).

- 2) Historic Fill: Non-hazardous contaminated waste also includes historic fill as defined in 6 NYCRR Part 375. Historic fill material means non-indigenous or non-native material, historically deposited or disposed in the general area of, or on a site to create usable land by filling water bodies, wetlands or topographic depressions, which is in no way connected with the subsequent operations at the location of the emplacement, and which was contaminated prior to emplacement. Historic fill may be solid waste including, but not limited to, coal ash, wood ash, municipal solid waste incinerator ash, construction and demolition debris, dredged sediments, railroad ballast, refuse and land clearing debris, which was used prior to October 10, 1962. Any soil or soil-like wastes from any area which was operated by a municipality or other person as a landfill is not considered historic fill.
  - c. Construction and Demolition (C&D) Debris: Uncontaminated solid waste resulting from the construction, remodeling, repair and demolition of utilities, structures and roads; and uncontaminated solid waste resulting from land clearing. Such waste includes, but is not limited to bricks, concrete, and other masonry materials, rock, and uncontaminated soil. Uncontaminated solid waste means C&D debris that is not mixed or comingled with other solid waste at the point of generation, processing or disposal, and that is not contaminated with spills of a petroleum product, hazardous waste, or industrial waste. Contamination from spills of a petroleum product does not include asphalt or concrete pavement that has come in contact with petroleum through normal vehicle use of the roadway.
  - d. Non-hazardous Petroleum-contaminated Waste: Exhibits a discernible petroleum-type odor, contains visible petroleum product, or may be associated with a reported spill.
2. Non-regulated Solid Waste: This applies to materials that, before being beneficially used (as determined by the NYSDEC or applicable Out-of-State Regulatory Agency) were solid waste. Material is no longer considered solid waste when used as described below:
  - a. uncontaminated soil which has been excavated as part of a construction project, and which is being used as a fill material, in place of soil native to the site of disposition;

- b. non-hazardous contaminated soil which has been excavated as part of a construction project, other than a NYSDEC-approved or undertaken inactive waste disposal site remediation program, and which is used as backfill for the same excavation or excavations containing similar contaminants at the same site (excess materials on these projects are subject to the requirements of 6 NYCRR Part 360);
- c. recognizable, uncontaminated concrete and concrete products, asphalt pavement, brick, glass, soil and rock placed in commerce for service as a substitute for conventional aggregate;
- d. non-hazardous petroleum-contaminated soil when incorporated into asphalt pavement products by a producer authorized by the NYSDEC;
- e. and all other uses as described in 6 NYCRR Part 360, Section 360-1.15, Beneficial Use. Note the NYSDEC will no longer consider asphalt millings to be recognizable if millings are combined with soil.

#### 1.06 SAMPLING REQUIREMENTS

##### A. Uncontaminated Soil:

- 1. Under 360-1.15(b)(7), soil may be determined to be uncontaminated, without sampling, if two or more of the following criteria can be satisfied:
  - a. When environmental due diligence performed under a recognized protocol (such as those included in DER-10 Chapter 3) determines that soil or fill is uncontaminated (i.e., that there is no history of spills or releases, or mixture with other solid wastes, including cinders or ash).
  - b. When it is determined to be native and uncontaminated based on observation of the site vegetation in conjunction with other indicators such as soil morphology as determined by a qualified soil scientist, geologist, environmental scientist, or professional engineer.
  - c. When existing data indicate that non-native soil such as common fill is uncontaminated.
- 2. Sampling is required when information cited above is not available or when environmental due diligence indicates a potential for an existing or historical impact (e.g., spill or release) in soil to be excavated, but the extent and magnitude have not yet been defined.

## GENERAL SPECIFICATION 02105 SOIL SAMPLING AND ANALYSIS

---

3. Sampling is performed within the planned excavation boundaries and receiving areas to define contamination boundaries and to allow a comparison to confirm similarity of contaminants.
  4. Analytical data is used to determine whether soil may be reused at any site without restriction (meets soil cleanup objectives [SCOs] in 6 NYCRR Part 375-6.8(a), parameters of CP-51, and most recent supplemental SCOs, as applicable).
- B. Non-Hazardous Contaminated Soil:
1. Under 6 NYCRR 360-1.15(b)(8), non-hazardous, contaminated soil may be reused within the same site, without sampling, provided the type of contaminants and origin are understood; and the receiving area is known to be affected similarly (e.g., same types of contaminants, same general concentrations, same site history).
  2. Sampling is required when the information cited above is not available; or when known historical impacts are not well understood; or to define contamination boundaries. Same numbers of composite and discrete samples from excavation and receiving areas shall be analyzed and results compared by ranges in concentration for individual parameters.
  3. Analytical data is used to determine whether soil may be reused at any site, with the exception of ecologically sensitive and agricultural locations, as fill and cover (meets the lower of 6 NYCRR Part 375-6.8(b) Protection of Public Health Residential and Protection of Groundwater SCOs, as applicable); or soil may be reused on the same site provided environmental due diligence and testing show that the material being excavated is non-hazardous and will be used as backfill in an area containing similar contaminants.
- C. It shall be noted that when relocating soils on the same site, hazardous soils, non-soil wastes, or hot spots, as evidenced by visual observation, hand-held instruments or analytical results, must not be incorporated. All such material shall be removed off-site for disposal.

### 1.07 SUBMITTALS

- A. The Contractor shall submit Shop Drawings and other materials for the approval of the Engineer. Submittals shall include, but not be limited to:
1. DEP Environmental, Health, and Safety (EH&S) Drilling and Boring Checklist: A completed EH&S Drilling and Boring Checklist shall be submitted to the Engineer a minimum of 60 days prior to the proposed commencement of the drilling/boring work. No drilling/boring work shall be performed at the site without obtaining written approval of the EH&S Drilling and Boring Checklist from the Engineer. An updated checklist shall be submitted whenever there is a change of the drilling

subcontractor or scope of drilling/boring work; or new EH&S hazards have to be considered in performing the work. The EH&S Drilling and Boring Checklist is located in the Detailed Specifications.

2. Field Sampling Plan (FSP): A FSP shall be submitted to the Engineer for approval 30 days following notice to proceed. The Engineer will approve the FSP only if it clearly provides a means to collect the information necessary to allow for classification of all material proposed for excavation and if it will ultimately generate data necessary to gain approval from the Contractor's chosen reuse or disposal sites. No sampling shall be conducted until the Engineer has reviewed and formally approved the FSP in writing. The FSP shall include the following at a minimum:
  - a. Protocols for the collection and analysis of samples that represent all soils to be excavated.
    - 1) Each composite sample will be comprised of multiple (3-5) discrete samples that are representative of the horizontal and vertical extent of the excavation footprint.
    - 2) Two discrete (biased worst case) VOC samples will be collected for every one composite sample.
    - 3) When soils are visibly heterogenous, composite samples will be obtained to represent each visually different stratum or section of the excavation site, regardless of the overall excavation volume.
  - b. A detailed outline of the BUD or disposal facility requirements for sampling, testing and analysis including specific number and types of samples per unit volume of soil to be excavated.
  - c. Parameters analyzed for soils to be reused on-site, and reused or disposed off-site shall be as described in Article 3.01.
  - d. A scaled site map showing:
    - 1) existing fixed landmarks;
    - 2) proposed excavation limits or area to be excavated divided into distinct vertical and horizontal grids, identifying the volume of soil or fill that each sample will represent;
    - 3) specific sampling locations that are representative of the entire depth of excavation and that will conform to the applicable sampling frequency requirement;



## GENERAL SPECIFICATION 02105 SOIL SAMPLING AND ANALYSIS

---

- 4) identification numbers of the sample grids, relative depth, sampling intervals, and volumes reflective of the Contractor's excavation method.
  - a) Sampling intervals shall account for existing subsurface data, historic sampling information, including descriptions, depths, orientation, and location of material of potentially different classifications, and shall minimize undue mixing of excavated soils.
- e. Proposed sampling, handling, preservation, and storage of equipment and procedures, including transfer procedures, and sampling equipment decontamination procedures.
- f. Proposed analytical methods, in accordance with SW-846, latest edition, for the analyses to be performed.
- g. Procedures for assessing precision, accuracy, degree of representation, comparability and completeness of samples and data, including performance audits and proposed protocols for corrective measures where problems are identified in accordance with Article 1.09 -- Quality Assurance.
- h. Schedule of field inspections.
- i. A statement that the sampling program is in accordance with the Contract requirements.
- j. Manufacturer, catalog data and calibration records of all analytical equipment to be used on-site.
- k. Name and address of analytical laboratory, copy of laboratory certification, and Quality Assurance Manual.
- l. Description of QA/QC samples and any additional requirements of the reuse or disposal facilities.
- m. The organizational structure of the Contractor's and all subcontractors' quality management (QM) personnel, including their:
  - 1) names, titles and contact information;
  - 2) resumes;
  - 3) responsibilities;
  - 4) authorities; and
  - 5) qualifications.

3. Field Sampling Summary Report (FSSR): Hard copies of the FSSR shall be submitted to the Engineer for review in a timeframe, dependent on the extent of the data collection effort, determined by the Engineer at the time. The FSSR shall contain all laboratory analytical results obtained from the field sampling event and shall allow the Engineer to determine if the soil is acceptable for beneficial use or requires disposal at a permitted solid waste disposal facility. At minimum, the FSSR shall include the following information:
  - a. A detailed account of any field procedures used which deviated from those established in the FSP.
  - b. A summary table listing the analytical results (with individual ID for each sample) with highlighted exceedances of RCRA Characteristics, BUD, and all disposal facility limits, including any alternate acceptance criteria.
    - 1) Data shall also be compared to the NYSDEC Subpart 375-6.8(a) and (b) SCOs, and CP-51 SSCOs, as applicable.
  - c. Location of each sampling point (using individual ID from analytical results summary table) on the scaled site map created in the FSP.
  - d. A complete set of field notes collected and maintained by the Contractor during sampling. The field notes shall be made available to the Engineer during the sampling program.
  - e. Boring or probe logs from each sampling location containing a continuous stratigraphic description of all material encountered. Descriptions of material shall include, but not be limited to, color, odor, staining, field screening measurement, relative grain size distribution, material composition, moisture content, and cohesive properties.
  - f. Depth intervals for each sample, whether a grab or composite, and any special notes, which are included on the laboratory chain-of-custody forms.
  - g. Copies of all laboratory chain-of-custody forms for samples that are collected for analysis.
4. Analytical Results: The Contractor shall submit analytical results for sampled soil material to the Engineer within three (3) business days of receiving such data from the laboratory. Analytical results data shall be managed by utilizing a computer spreadsheet or database program as approved by the Engineer. Data shall be organized in such a way that all samples may be tracked from collection through analysis.

## GENERAL SPECIFICATION 02105 SOIL SAMPLING AND ANALYSIS

---

- a. The analytical results generated for a ten (10) business day turnaround time deliverable shall include a Form I (or equivalent) showing compounds analyzed for, and concentrations detected, and associated chain-of-custody reports to the Engineer.
- b. The final data package generated by the laboratory shall include the following information:
  - 1) A Form I showing pertinent physical data presented in concise, easy to follow formats (i.e., sample number, laboratory ID, client, date of sample preparation, date analyzed, percent moisture, dilution factor, sample matrix, units, undetected and detected compounds, etc.).
  - 2) Reference to analytical methodology used.
  - 3) General discussion including a description of sample types, tests performed, any problems encountered, and any general comments (case narrative).
  - 4) Data from each discrete sample reported using cross-referencing between site samples and quality control samples and including all pertinent dates, information and reporting limits.
  - 5) Associated quality control samples such as blanks, spikes and spike duplicates, laboratory duplicates, laboratory control samples, field duplicates and appropriate check standards.
  - 6) Copies of chain-of-custody sheets.
  - 7) Analytical results in tabular Microsoft Excel format with highlighted exceedances of the RCRA Characteristics, BUD, or applicable parameters of 6NYCRR Part 375 SCOs and CP-51 Supplemental SCOs, as applicable, and all disposal facility limits, including any alternate acceptance criteria as part of the FSSR and disposal facility application packages submitted to the Engineer for review and approval.
  - 8) The information must be delivered on CD or via electronic mail to the Engineer. All electronic data must be certified to be virus-free.

### 1.08 OFF-SITE REUSE/DISPOSAL FACILITY

- A. The Contractor shall submit the name(s) of the selected off-site soil reuse and disposal facilities and their location(s) to the Engineer for approval.

## GENERAL SPECIFICATION 02105 – SOIL SAMPLING AND ANALYSIS

---

- B. Reuse of excavation spoils off-site must be prioritized over disposal. Disposal facilities shall only be approved where reuse options are not available.
- C. Note that some companies may have multiple reuse or disposal facilities, each possessing differing requirements regarding the types of materials accepted, the specific analytical testing parameters that must be performed for each material, and the frequency of sampling required for each material. It is the Contractor's responsibility to determine the specific waste acceptance criteria and testing requirements for each of its proposed facilities.
- D. The Contractor shall confirm the location(s) and permit status, as well as check for outstanding violations and enforcement actions at each selected reuse or disposal facility. The Engineer shall verify the information provided by the Contractor for each facility prior to approval.
- E. The Contractor shall verify types of materials accepted, the specific analytical testing parameters that must be performed for each material, and the frequency of sampling required for each material, at each of the chosen facilities.
- F. If an approved facility is not available during construction, the Contractor shall be fully responsible for procuring alternate approved facilities at no additional cost to the City. Any additional sampling and analysis required and labor involved in selecting new facilities after the initial reuse or disposal facilities are accepted shall be the responsibility of the Contractor.

### 1.09 QUALITY ASSURANCE

- A. Laboratory Requirements:
  - 1. The Contractor shall provide the services of a laboratory certified by the New York State Department of Health Environmental Laboratory Approval Program (NYSDOH-ELAP) to perform applicable testing and chemical analyses for the duration of the Work.
  - 2. The laboratory shall also meet the certification requirements of the reuse or disposal facility that will be utilized by the Contractor for the duration of the Work.
- B. Permits and Regulations:
  - 1. The Contractor shall obtain all necessary permits and perform all work in compliance with applicable requirements of OSHA, and other governing authorities having jurisdiction.
- C. Field QA/QC Samples:
  - 1. Shall be collected and analyzed in accordance with the protocol for site samples.

## GENERAL SPECIFICATION 02105 SOIL SAMPLING AND ANALYSIS

---

2. The number of QA/QC samples required for a quantity of soil shall meet all reuse or disposal facility requirements, and the approval of the Engineer.
  3. Field duplicate samples shall be collected for a minimum of 5 percent of the samples spaced throughout the sample program.
- D. Sample Turn-Around: The Contractor shall provide for prompt sampling and turn-around of analysis so as not to delay the project. If a turn-around time of less than ten (10) business days is required due to delays in construction scheduling or other constraints, Contractor shall provide for such at no additional cost to the City.
- 1.10 DELIVERY, STORAGE AND HANDLING
- A. Sample Identification:
1. All samples shall be identified with a sample label in addition to an entry on a chain-of-custody record. The label shall be identified upon receipt by the laboratory and cross-referenced to the chain-of-custody record.
  2. Any inconsistencies shall be noted on the custody record. Laboratory personnel shall notify the Sampling and Analysis Manager immediately if any inconsistencies exist in the paper work associated with the samples, and Contractor shall collect new samples to replace those with inconsistencies which cannot be rectified.
- B. Sample Labels: The field team shall complete the following information on a sample label for each sample bottle:
1. Site Name
  2. Job Number
  3. Sample Number
  4. Sample Description
  5. Company Name
  6. Parameters to be Analyzed
  7. Date
  8. Time
  9. Preservation Technique Employed
  10. Sample labels shall be attached to the sample bottles
- C. Completion of Chain-of-Custody Record:
1. Maintain a chain-of-custody record on all samples. A chain-of-custody record is a printed multi-part form that accompanies a sample or group

of samples as custody is transferred from person to person. A chain-of-custody record is a controlled document.

2. As soon as is practical after sample collection, preferably after decontamination, the following information shall be entered on the chain-of-custody form. All information shall be recorded in ink.
  - a. Project number: Enter the alphanumeric designation assigned by the field team that uniquely identifies the project site.
  - b. Project name: Enter the site name.
  - c. Samplers: Sign the name(s) of the sampler(s).
  - d. Station number: Enter the sample number for each sample in the shipment. This number appears on the sample identification label.
  - e. Date: Enter a six-digit number indicating the year, month, and day of sample collection.
  - f. Time: Enter a four-digit number indicating the time of collection in 24-hour time, for example, 13:54.
  - g. Matrix/Type: Indicate the type of sample; composite or grab.
  - h. Station location: Describe the location where the sample was collected.
  - i. Number of containers: For each sample number, enter the number of sample bottles that are contained in the shipment.
  - j. Remarks: Enter any appropriate remarks.

D. Sample Shipment:

1. Custody of samples shall be maintained throughout the shipment of samples to the selected laboratory (ies). All samples shall be packaged and shipped daily to ensure that no sample is held at the site more than 24 hours. Samples shall be delivered directly to the laboratory using the following procedures:
  - a. Use waterproof high-strength plastic ice chests or coolers only.
  - b. After filling out the pertinent information on the sample label and tag, put the sample in the bottle or vial and screw on the lid. For bottles other than VOC sample bottles, secure the lid with tape (tape on VOC bottles may cause contamination).
  - c. Place inert cushioning material such as vermiculite or "bubble-wrap" in the bottom of the cooler.

## GENERAL SPECIFICATION 02105 SOIL SAMPLING AND ANALYSIS

---

- d. Enclose the bottles in clear plastic bags through which sample labels are visible, and seal the bag. Place bottles upright in the cooler in such a way that they do not touch and will not touch during shipment.
  - e. Put in additional inert packing material to partially cover sample bottles (more than half-way). Place double-bagged crushed ice around, among, and on top of the sample bottles.
  - f. Fill cooler with cushioning material.
  - g. Put paperwork (chain-of-custody record) in a waterproof plastic bag and tape it with packing tape to the inside lid of the cooler.
  - h. Tape the drain shut.
  - i. Secure lid by taping. Wrap the cooler completely with strapping tape at a minimum of two locations. Do not cover any labels.
  - j. Attach completed shipping label to top of the cooler.
  - k. Put "This Side Up" labels on all four sides and "Fragile" labels on at least two sides of coolers containing glass containers.
  - l. Ship the cooler overnight by commercial carrier (e.g., Federal Express, UPS), laboratory carrier or field personnel to the respective laboratory.
2. Custody forms for the samples shall be signed by the Contractor's designated representative who is relinquishing custody. The custody form shall include the air bill number, method of shipment, and time and date of the transfer of custody.
  3. Custody seals shall be applied to the front and back of the sample coolers. A shipping label with return address shall be applied as well as the air express bill and any Department of Transportation (DOT) required labels or markings.
- E. Transferring Custody of Samples to Shipper, if applicable: Contractor shall transfer custody of samples to a shipper as follows:
1. Sign, date, and enter time on the chain-of-custody report under "Relinquished by."
  2. Make certain that shipper signs the "Received by" entry.
  3. Enter name of the carrier under next "Relinquished by" category. Receiving laboratory shall sign "Received for Laboratory by" on lower line and enter date and time.
- F. Transferring Custody from Sampler or Shipper to Common Carrier:

## GENERAL SPECIFICATION 02105 – SOIL SAMPLING AND ANALYSIS

---

1. The shipper or Contractor shall transfer custody of samples to a common carrier as follows:
  - a. Sign, date, and enter time under "Relinquished by" entry.
  - b. Enter name of carrier (e.g., UPS, Federal Express) under "Received by."
  - c. Enter bill-of-lading or Federal Express airbill number under "Remarks."
  - d. Place the original of the chain-of-custody form in the appropriate sample shipping package. Retain a copy with field records.
  - e. Sign and date the custody seal. The custody seal is part of the chain-of-custody process and is used to prevent tampering with samples after they have been collected in the field.
  - f. Wrap the seal across filament tape which has been wrapped around the hinges of the shipping package at least twice.
  - g. Fold the custody seal over on itself so that it sticks together.
  - h. Complete other carrier-required shipping papers.
2. In instances when the Common Carrier will not accept responsibility for handling chain-of-custody forms, the Contractor shall ensure that the record is packed within the sample package.

G. Laboratory Custody Procedures: Once the samples arrive at the laboratory, the Contractor shall ensure that custody of the samples is maintained by laboratory personnel. The laboratory shall, at a minimum, document the chain of custody through each stage of analysis from receipt to final reporting.

### 1.11 PROJECT CONDITIONS

- A. Stockpiling: There may be circumstances that prevent in-situ sampling. In these cases, stockpiling of excavated soils on site or ex-situ sampling shall require written approval from the Engineer.
1. If stockpiling is considered necessary, and approved by the Engineer, sampling shall be conducted by collecting representative grab samples throughout the soil stockpile. Surface soil shall not be used as sampling material. The Contractor is also required to satisfy the specific sampling requirements of the reuse or disposal facility.
  2. During stockpiling activities, the Engineer may identify quantities within each 500 cubic yard portion that differ in appearance from the bulk of the material. In this case, the Engineer will direct the Contractor to segregate these variable materials for stockpiling on-site.



## GENERAL SPECIFICATION 02105 SOIL SAMPLING AND ANALYSIS

---

3. All stockpiles of excavated materials shall be handled on site as required in General Specification 02371 – Dust, Soil Erosion and Sedimentation Control.
- B. Decontamination of Sampling Equipment: All sampling equipment shall be certified clean or precleaned, prior to collection of each sample, by the following method:
1. Wash all sampling equipment, secondary containers (e.g., mixing bowls for composite sampling) and aluminum foil with non-phosphate laboratory grade detergent and distilled water.
  2. Triple rinse with distilled water.
  3. Rinse with isopropyl alcohol, or if samples are visibly contaminated with petroleum use a solvent, such as hexane or other alternate approved by the Engineer.
  4. Triple rinse with analyte-free water.
- C. Disposal of Decontamination Solutions: Collect all decontamination solution and dispose of it through a licensed chemical waste disposal service if it is unsuitable for treatment on-site by incorporation into existing on-site treatment processes as defined in General Specification 02240 – Dewatering.

### PART 2 PRODUCTS (NOT USED)

### PART 3 EXECUTION

#### 3.01 TESTING

- A. Parameters analyzed for soils to be reused on-site shall be at a minimum EPA 6010 and EPA 7471 for the RCRA-14 list of metals (i.e., antimony, arsenic, barium, beryllium, cadmium, total chromium, copper, lead, mercury, nickel, selenium, silver, vanadium and zinc), unless knowledge of the material or results of prior sampling and analysis justify analysis for fewer metals; EPA 8270D SVOCs (entire Target Compound List); if there is concern about potential impact from historic fill, C&D debris or site history, the parameter list will be expanded to include the following, as applicable:
1. EPA 8082 PCB's
  2. EPA 8081 Pesticides
  3. EPA 8260 VOCs
  4. Additional constituents from Commissioner Policy CP-51 and the most recent Supplemental Soil Cleanup Objectives (SSCOs)
  5. RCRA Characteristics including ignitability, corrosivity, reactivity, and Toxicity Characteristic Leaching Procedure (TCLP) for metals and

## **GENERAL SPECIFICATION 02105 – SOIL SAMPLING AND ANALYSIS**

---

SVOCs. Additionally, TCLP VOCs, pesticides and herbicides, shall be analyzed as applicable.

- B. Parameters analyzed for soils to be reused or disposed off-site shall be the RCRA Characteristics identified above at a minimum, in addition to any other parameters required by the reuse or disposal facility.
- C. Unless otherwise specified in the Detailed Specification or required by the reuse or disposal facility, the sampling frequency, based on anticipated soil excavation volumes in cubic yards (CY) shall be as follows:
  - 1. 0-500 CY: 1 composite sample, 2 discrete (VOC) samples
  - 2. 501-1000 CY: 2 composite samples, 2 discrete (VOC) samples
  - 3. 1001-10,000 CY: Add 1 composite sample, 2 discrete (VOC) samples for each additional 1000 CY
  - 4. Greater than 10,001 CY: Add 1 composite sample, 2 discrete (VOC) samples for each additional 2,500 CY
- D. Classification of soils for reuse or disposal shall be carried out by the Engineer.
- E. Conduct testing in accordance with the Detailed Specifications and the approved FSP.
- F. Field sampling shall be completed in ample time to prevent delay of the excavation work or the work of any other contractor.

END OF SECTION

**SECTION 02222  
Demolition and Removals**

**PART 1 GENERAL**

**1.01 SECTION INCLUDES**

- A. The Contractor shall provide all labor, materials, equipment and incidentals as shown, specified and required to complete the demolition, removal, disposal and relocation Work.
- B. Included, but not limited to, are demolition and removals of existing materials, structures, equipment, or work necessary to install the new Work, as shown and specified and to connect same with existing work in an approved manner. Demolition includes structural concrete, foundations, walls, doors, windows, structural steel, metals, roofs, masonry, attachments, appurtenances, piping, electrical and mechanical equipment, paving, curbs, walks, fencing, and similar existing facilities.
- C. Demolitions and removals which may be specified under other Sections shall conform to requirements of this Section.
- D. The Contractor shall obtain all required permits from the City and other agencies having jurisdiction.
- E. The following index of this Section is presented for convenience:

<u>Article</u>	<u>Title</u>	<u>Page</u>
		02222-
PART 1	GENERAL .....	1
1.01	Section Includes .....	1
1.02	Payment.....	2
1.03	Related Sections.....	2
1.04	References.....	2
1.05	Submittals .....	2
1.06	Job Conditions .....	3
1.07	Pre-Demolition Meeting .....	5
PART 2	PRODUCTS (NOT USED) .....	5
PART 3	EXECUTION.....	5
3.01	General.....	5
3.02	Structural Removals.....	8
3.03	Mechanical Removals.....	8
3.04	Pavement, Curb And Sidewalk Removals .....	9
3.05	Electrical Removals .....	9
3.06	Miscellaneous Removals .....	10
3.07	Modifications And Closures .....	10
3.08	Maintenance And Clean Up.....	11

## GENERAL SPECIFICATION 02222 - DEMOLITION AND REMOVALS

---

### 1.02 PAYMENT

- A. Unless otherwise provided in the Detailed Specifications, no separate payment will be made for performing any work required under this Section and the Contractor shall include all costs thereof in its lump sum price for the Contract.

### 1.03 RELATED SECTIONS

- A. Section 02105 - Soil Sampling and Analysis
- B. Section 02316 - Excavation
- C. Section 02371 - Dust, Soil Erosion and Sedimentation Control.

### 1.04 REFERENCES

- A. 29 CFR 1926 - Safety and Health Regulations for Construction (Subpart T - Demolition)
- B. 29 CFR 1910 - Occupational Safety and Health Standards
- C. ANSI/ASSE A10 - Construction and Demolition Safety Standards
- D. AWS D12.1 - Reinforcing Steel Welding Code
- E. New York City Department of Environmental Protection (NYCDEP)
  - 1. Environmental Health and Safety Policies and Procedures – Vol. III. Control of Hazardous Energy Lock-Out/Tag-Out, or latest version

### 1.05 DESCRIPTION

- A. Protection:
  - 1. Demolition and removal Work shall be performed by competent workers experienced in the various types of demolition and removal Work required. The Work shall be carried through to completion with the prevention of damage to structures and the adjacent property and with due regard to the safety of City employees, work persons on the site, and the public. The Work will be performed so as not to interfere with the use of, and free and safe passage to and from, adjacent structures.
  - 2. The Contractor shall provide, erect and maintain catch platforms, lights, barriers, weather protection, warning signs and other items as required for proper protection of the public, occupants of the building, work persons engaged in demolition operations, and adjacent construction.
  - 3. The Contractor shall provide and maintain weather protection at exterior openings so as to fully protect the interior premises against damage from the elements until such openings are closed by new construction.

## GENERAL SPECIFICATION 02222 - DEMOLITION AND REMOVALS

---

4. The Contractor shall provide and maintain temporary protection of the existing structure designated to remain where demolition, removal and construction work is being done, connections made, materials handled or equipment moved. The Contractor shall be responsible for any damage to the existing structure or contents by reason of providing insufficient protection.
5. The Contractor shall take necessary precautions to control dust as required by Section 31 25 10 – Dust, Soil Erosion and Sediment Control. Dust shall be prevented from rising by wetting demolished masonry, concrete, plaster and similar debris. All portions of the existing buildings affected by the operations under this Section shall be protected by dustproof partitions and other adequate means.
6. The Contractor shall monitor the atmosphere inside the aeration tanks, in particular for the presence of hazardous gases, in accordance with the requirements of this Contract and all applicable laws and regulations.
7. The Contractor shall provide adequate fire protection in accordance with local Fire Department requirements.
8. The Contractor shall carry out all operations so as to avoid interference with operations and work in the existing facilities and the work under other contracts.
9. The Contractor shall be solely responsible for making all necessary arrangements and for performing all necessary work involving the discontinuance or interruption of all utilities or services.
10. Any equipment, piping and appurtenances removed without proper authorization, and that are necessary for the operations of the existing or expanded facilities, shall immediately be replaced to the satisfaction of the Engineer at no cost to the City.
11. Closing or obstructing of roadways, sidewalks, and passageways adjacent to the work by the placement or storage of materials will not be permitted, and all operations shall be conducted with minimum interference to traffic.
12. The Contractor shall repair damage caused by its operations to existing structures and equipment to remain, or to any property belonging to the City or its employees.
13. The Work shall comply with 29 CFR Part 1926 -- Safety and Health Regulations for Construction, applicable provisions and recommendations of ANSI/ASSE A10 -- Construction and Demolition Safety Standards, New York City Construction Code, New York City Electrical Code, all other governing codes and rules, and as specified herein or shown in the Contract Documents.

## GENERAL SPECIFICATION 02222 - DEMOLITION AND REMOVALS

---

14. The Contractor shall make such investigations, explorations and probes as are necessary to ascertain any required protective measures before proceeding with demolition and removal.
  15. Demolition and removal of hazardous materials shall be in accordance with applicable federal, State and Local regulations.
- B. Permits: Obtain all permits from all appropriate regulatory agencies required for closing or obstructing streets and sidewalks. Obtain all air permits as required for demolition of any building or structure located in New York City including a Demolition Permit from the Department of Buildings and a DEP Registration for Demolition from the Department of Environmental Protection, Bureau of Environmental Compliance.
- C. Condition of Buildings, Structures and Equipment:
1. The City does not assume responsibility for the actual condition of buildings, structures and equipment to be demolished and removed.
  2. Conditions existing at the time of inspection for bidding purposes will be maintained by the City so far as practicable. However, there is no guarantee by the City that the number of fixtures, amount of equipment or any other material of value existing at bidding time in the buildings and structures to be demolished will be present in the structures when they are demolished. The Contractor shall have no claim against the City because of the absence of such fixtures and materials.
  3. The conditions of existing structures and equipment shown on the Contract Documents is based on visual inspection and a walk-through survey only. Neither the Engineer nor the City will be responsible for interpretations or conclusions drawn therefrom by Contractor.
- D. Scheduling: The Contractor shall carry out operations so as to avoid interference with City's operations and work in the existing facilities.
- E. Notification: At least 48 hours prior to commencement of a demolition or removal, Contractor shall notify the Engineer in writing of his proposed schedule. City will inspect the existing equipment or facilities and review with the Contractor those items which are to remain the property of the City. No removals shall be started without the permission of the Engineer.
- F. Coordination: The Contractor shall coordinate all electrical shutdowns with the Engineer and the Plant's Responsible Individual as defined in the DEP Policies and Procedures. The Contractor shall confirm all equipment is de-energized, and install required lock-out and tag-out devices on electrical equipment to prevent accidental re-energizing of the equipment.
- G. PRE-DEMOLITION MEETING

## **GENERAL SPECIFICATION 02222 - DEMOLITION AND REMOVALS**

---

1. The Contractor shall have a pre-demolition meeting with the Engineer and representatives of other related construction contracts, if any, in the presence of the Resident Engineer, to review all of the work areas that will be affected by the removal of materials from demolition.

### 1.06 QUALITY ASSURANCE

- A. Not Used

### 1.07 SUBMITTALS

- A. Contractor shall submit Shop Drawings and material specifications for the approval of the Engineer. Submittals shall include, but not be limited to proposed methods, equipment and operating sequences to be used in performance of the demolition and removals work and handling of hazardous materials.
- B. The Contractor shall demonstrate how coordination of operations and sequence for shut-off, capping, temporary services, continuation of utility services, and other applicable items will be provided to ensure no interruption of City's operations.
- C. Sequence and Schedule: The Contractor shall submit a detailed schedule showing the sequence and duration of demolition activities.

### 1.08 DELIVERY, STORAGE, AND HANDLING

- A. Not Used

### 1.09 SPARE PARTS, SPECIAL TOOLS, AND SUPPLIES

- A. Not Used

### 1.10 SPECIAL WARRANTY PROVISIONS / GUARANTEE PERIODS

- A. Not Used

## PART 2 PRODUCTS (NOT USED)

### 2.01 MANUFACTURERS

- A. Not Used

### 2.02 MATERIALS / EQUIPMENT

- A. Not Used

### 2.03 FABRICATION / ASSEMBLING / FINISHES

- A. Not Used

### 2.04 SOURCE QUALITY CONTROL / SHOP TESTS

- A. Not Used

PART 3 EXECUTION

3.01 EXAMINATION / PREPARATION

- A. Not Used

3.02 IMPLEMENTATION

A. GENERAL

1. The Work required shall be done with care, and shall include all necessary shoring, bracing, and support to prevent movement, settlement, or collapse of existing structures or facilities. The Contractor shall be responsible for any damage caused by demolition and removal Work to any part or parts of existing structures or equipment designated for reuse or to remain. The Contractor shall perform patching, restoration and new work in accordance with applicable technical sections of the Specifications and in accordance with the details shown on the Contract Drawings.
2. Surfaces of walls, floors, ceilings, or other areas which are exposed by any of the removals specified herein, and which will remain as architecturally finished surfaces, which have holes, scars, chipped or other damaged surfaces revealed by the removal, shall be repaired by the Contractor with the same or matching materials as the existing surface or as may be otherwise approved by the Engineer.
3. Pollution Controls: Use water sprinkling, temporary enclosures, and other suitable methods to limit the amount of dust and dirt rising and scattering in the air to the lowest practical level. Comply with General Specification 02371 – Dust, Soil Erosion and Sedimentation Control and all governing regulations pertaining to environmental protection.
  - a. Do not use water when it may create hazardous or objectionable conditions such as ice, flooding, and pollution.
  - b. Clean adjacent structures, facilities, and improvements of dust, dirt, and debris caused by demolition operations. Return adjacent areas to conditions existing prior to the start of the work.
  - c. The use of calcium chloride for dust control will not be allowed.
4. All supports, pedestals and anchors shall be removed with the equipment and piping unless otherwise specified or required. Concrete bases, anchor bolts and other supports shall be removed to approximately one inch below the surrounding finished area, and the recesses shall be patched to match the adjacent areas. Superstructure wall and roof openings shall be closed, and damaged surfaces shall be patched to match the adjacent areas, as specified under applicable sections of the Specifications, , as shown on the Contract Drawings, or as directed by the



- Engineer. Wall sleeves and castings shall be plugged or blanked off, all openings in concrete shall be closed in a manner meeting the requirements of the appropriate sections of the Specifications, as shown on the Contract Drawings and as directed and approved by the Engineer.
5. Any materials or items designated to remain the property of the City shall be removed with care and stored at locations designated by the City.
  6. Where equipment is shown or specified to be removed and relocated, the Contractor shall not proceed with removal of this equipment without the prior approval of the Engineer. Upon approval, and prior to commencing removal operations, the equipment shall be operated in the presence of representatives of the Contractor, the City and the Engineer. Such items shall be removed with care, under the supervision of the trade responsible for reinstallation, and shall be protected and stored until required. Material or equipment damaged during removal shall be replaced with similar new material or equipment. Any equipment that is removed without proper authorization and is required for plant operation shall be replaced at no cost to the City.
  7. Wherever piping is to be removed for disposal, the Contractor shall drain the piping and adjacent pipe and headers that are to remain in service shall be blanked off or plugged and then anchored in an approved manner.
  8. Where alterations occur, or new and old work join, the Contractor shall cut, remove, patch, repair or refinish the adjacent surfaces to the extent required by the construction conditions, so as to leave the altered work in as good a condition as existed prior to the start of the work. The materials and workmanship employed in the alterations shall be of the same quality as required for new work of the same type.
  9. The Contractor shall confine cutting of existing roof areas designated to remain to the limits required for the proper installation of the Work. The Contractor shall cut and remove insulation and weather protection, and provide temporary weathertight protection as required until new roofing and flashings are installed.
  10. The Contractor shall remove enclosures, signs, guards, and the like when no longer required or when directed by the Engineer at the completion of the Work.
  11. The Contractor shall dispose of all demolition materials, equipment debris, and all other items not marked or specified by the City or the Engineer to remain as property of the City, off site and in conformance with the requirements of the Contract and all existing applicable laws and regulations.

12. Building Demolition:
  - a. Unless otherwise approved by the Engineer, proceed with demolition from the top of the structure to the ground. Complete demolition work above each floor or tier before disturbing supporting members of lower levels.
  - b. Demolish concrete and masonry in small sections.
  - c. Remove structural framing members and lower to ground by means of hoists, derricks, or other suitable methods.
  - d. Break up and remove foundations and slabs-on-grade, unless otherwise shown to remain.
  - e. Locate equipment used for demolition work, and remove demolished materials, so as not to impose excessive loads on supporting walls, floors or framing.
  - f. Regrade in accordance with General Specification 02316 - Excavation.
13. The Contractor shall de-energize and disconnect electrical service to all structures and equipment prior to demolition or relocation. No demolition activity shall commence prior to electrical disconnection.
14. All construction and demolition debris that has come in contact with regulated solid waste shall be cleaned to the satisfaction of the Engineer before leaving the site.
15. The use of explosives is not permitted.
16. Dust Control: The Contractor is responsible for controlling visible dust caused by demolition activities. Dust control shall be provided as described in General Specifications 02371 – Dust, Soil Erosion and Sedimentation Control.

**B. STRUCTURAL REMOVALS**

1. The Contractor shall remove concrete, structures and sub-structures to the lines and grades shown unless otherwise directed by the Engineer. The removal of masonry beyond these limits shall be at the Contractor's expense and these excess removals shall be reconstructed to the satisfaction of the Engineer with no additional compensation to the Contractor.
2. Determine the thickness of existing concrete to be removed and the extent to which it is reinforced. No additional compensation will be made because of variations from the thickness shown or for variations in the amount of reinforcement.

3. All concrete, stone, masonry, roofing materials, reinforcement, structural or miscellaneous metals, plaster, wire mesh and other items contained in or upon the structure shall be removed and taken from the site and disposed of at a permitted facility. Demolished items shall not be used in backfill.
4. After removal of parts or all of masonry walls, slabs and like work which tie into new work or existing work, the point of junction shall be neatly repaired so as to leave only finished edges and finished surfaces exposed.

C. MECHANICAL REMOVALS

1. Mechanical removals shall consist of dismantling and removing existing pipes, pumps, motors and other facilities as specified, shown, or required for the completion of the work. It shall include cutting, capping, draining, and plugging as required, except that the cutting of existing piping for the purpose of making connections thereto will be included under Division 15 of the Detailed Specifications.
2. Existing process, water, chemical, and other piping shall be removed where shown on the Contract Drawings. All removed piping shall be removed to the nearest solid support, capped and left in place. Piping shall be purged and made safe by the Contractor prior to removal or capping. Disposal of any chemicals or other purged material in accordance with the requirements of Detailed Specification 01355 -- Hazardous Materials Control and other applicable environmental, health, and safety (EHS) requirements of the Contract shall be the responsibility of the Contractor. Where piping that is to be removed passes through existing walls, it shall be cut off and properly capped on each side of the wall.
3. When underground piping is to be altered or removed, the remaining piping shall be properly capped. Abandoned underground piping may be left in place unless it interferes with new work or is shown or specified to be removed.
4. Any required demolition or changes to potable water piping and other plumbing system work shall be made in conformance with all applicable codes. Portions of the potable water system that may have been altered or opened shall be pressure tested and disinfected in accordance with the Detailed Specifications for Division 15 and local codes. Other plumbing piping and heating piping shall be pressure tested only.
5. Provide all caps, plugs, blind flanges, shut-off valves and other work and materials required to remove from service existing piping and necessary to keep existing piping in service where shown or required.

**D. PAVEMENT, CURB AND SIDEWALK REMOVALS**

1. Remove existing pavement, including base and surface courses, stabilized sub-bases, curbs, and gutters as required to construct new facilities or as shown. Before removing, saw a straight joint at least 1-1/2-inches deep between sidewalk and pavement designated for removal and that left in place. Curbs and gutters shall be removed to the nearest construction joint beyond the limit of demolition shown on the Drawings.
2. Provide for satisfactory transition between replaced pavement and sidewalks and the portions remaining in place.

**E. ELECTRICAL REMOVALS**

1. Electrical removals shall consist of the removal of existing generators, transformers, distribution switchboards, control panels, motors, conduits and wires, and miscellaneous electrical equipment all as shown, specified, or required to perform the work.
2. All existing electrical equipment and fixtures to be removed shall be removed with such care as may be required to prevent unnecessary damage to keep existing systems in operation and maintain the integrity of the grounding systems.
3. Distribution switchboards shall be removed or modified as shown. Switchboards to be removed shall be disconnected and dismantled, and all components shall be disposed of off the site. Circuit breakers and other control equipment on modified switchboards that will no longer be used shall be removed unless otherwise shown or specified. All new openings cut into the modified switchboard panels shall be cut square and dressed smooth to the dimensions required for the installation of the new equipment.
4. Motors shall be disconnected and removed where shown or specified. Motors not marked or designated by the City or the Engineer to be salvaged shall be removed from the site. Motors or other electrical gear designated for reuse shall be stored in enclosed, heated storage.
5. Conduits and wires shall be abandoned or removed where shown. All wires in abandoned conduits shall be removed, salvaged, turned over to the City and stored where directed by the Engineer. Abandoned conduits concealed in floor or ceiling slabs, or in walls, shall be cut flush with the slab or wall at the point of entrance. The conduits shall be suitably plugged and the area repaired in a flush, smooth, approved manner. Exposed conduits and their supports shall be disassembled and removed from the site. Repair all areas of work to prevent rust spots on exposed surfaces.

6. The Contractor shall coordinate all electrical shutdowns with the Engineer and the facility's Responsible Individual as defined in the DEP Policies and Procedures. The Contractor shall confirm all equipment is de-energized, and install required lock-out and tag-out devices on electrical equipment to prevent accidental re-energizing of the equipment.

**F. MISCELLANEOUS REMOVALS**

1. Contractor shall remove miscellaneous items where shown on the Drawings or where necessary for the construction of new structures or modification of existing structures. Anchor bolts shall be cut back one inch below the concrete surface and the hole patched.

**G. MODIFICATIONS AND CLOSURES**

1. Modifications shall conform to all applicable Specifications, the Drawings, and the directions and approvals of the Engineer.
2. Where alterations require cutting or drilling into existing floors, walls, and roofs, the holes shall be repaired in an approved manner. Contractor shall repair such openings with the same or matching materials as the existing floor, wall, or roof, or as otherwise approved by the Engineer. All repairs shall be smoothly finished unless otherwise approved by the Engineer.
3. Openings in existing concrete slabs, ceilings, roofs, masonry walls, floors and partitions which are not to be used in the new work shall be closed and sealed as shown or otherwise directed by the Engineer.
4. Where parts of existing structures are to remain in service, demolish the portions to be removed, repair damage, and leave the structure in proper condition for the intended use. Remove concrete and masonry to the lines designated by drilling, chipping, and other suitable methods. Leave the resulting surfaces true and even, with sharp straight corners that will result in neat joints with new construction or be satisfactory for the purpose intended. Where existing reinforcing rods are to extend into new construction, remove the concrete so that the reinforcing is clean and undamaged. Cut off other reinforcing flush with the surface.
5. New work shall be keyed into the existing in an acceptable manner. New reinforcing steel shall be welded to the existing reinforcing. Welding shall conform to AWS D12.1, Reinforcing Steel Welding Code. In general, the same or matching materials as the existing adjacent surface shall be used. The finished closure shall be a smooth, tight, sealed, permanent closure with all exposed surfaces smooth finished and acceptable to the Engineer.

**H. MAINTENANCE AND CLEAN UP**

## **GENERAL SPECIFICATION 02222 - DEMOLITION AND REMOVALS**

---

1. Contractor shall maintain the buildings, structures, and other City properties free from accumulations of waste, debris, and rubbish caused by the demolition and removal operations.
2. Contractor shall provide on-site dump containers for collection of waste materials, debris and rubbish, and shall wet down dry materials to prevent blowing dust.
3. At reasonable intervals during the progress of the demolition and removal work or as directed by the Engineer, the Contractor shall clean the Site and properties and dispose of all waste materials in accordance with the applicable regulations and requirements of this Contract.

### 3.03 FIELD TESTING / QUALITY CONTROL

- A. Not Used

### 3.04 STARTUP / DEMONSTRATION

- A. Not Used

### 3.05 ADJUSTING / PROTECTION / CLEANUP

- A. Not Used

END OF SECTION

**SECTION 02230  
Site Clearing**

**PART 1 GENERAL**

**1.01 SECTION INCLUDES**

- A. The Contractor shall provide all labor, tools, equipment, materials and incidental items required to perform site clearing of all designated areas within the Contract limits and as shown on the Contract Drawings, including work specified in permits and other agreements, in accordance with the requirements of the Contract Documents
- B. The Contractor shall develop and implement an Emerald Ash Borer (EAB) Management Plan that provides for compliance with the latest EAB Quarantine Order(s), as applicable to the location of work. Work includes, but is not limited to, the performance of a site survey by an appropriately qualified professional when the site is located in an EAB Quarantine Zone, and written protocol for the management of EAB Regulated Articles.
- C. The Contractor shall develop and implement an Asian Longhorned Beetle (ALB) Management Plan that provides for compliance with 7 CFR 301.51 and NYCRR Title 1 Part 139, as applicable to the location of work. Work includes, but is not limited to, the performance of a site survey by an appropriately qualified professional when the site is located in an ALB Quarantine Zone, and written protocol for the management of ALB Regulated Articles.
- D. The following index of this Section is included for convenience:

<u>Article</u>	<u>Title</u>	<u>Page</u>
		02230-
PART 1	GENERAL .....	1
1.01	Section Includes .....	1
1.02	Payment.....	2
1.03	Related Sections.....	2
1.04	References.....	2
1.05	Definitions & Explanations.....	2
1.06	Quality Assurance.....	4
1.07	Project/Site Conditions .....	4
1.08	Guarantee .....	4
1.09	Submittals .....	4
PART 2	PRODUCTS (NOT USED) .....	10
PART 3	EXECUTION.....	10
3.01	Trees and Shrubs to be Saved.....	10
3.02	Removal of Trees and Shrubs.....	12
3.03	Certified Arborist.....	12

**GENERAL SPECIFICATION 02230 SITE CLEARING**

---

3.04 Emerald Ash Borer Quarantine Zone .....12  
3.05 Asian Longhorned Beetle Quarantine Zone .....13  
3.06 Clearing and Grubbing.....13  
3.07 Stripping Topsoil .....14

1.02 PAYMENT

- A. Unless otherwise provided in the Detailed Specifications, no separate payment will be made for performing any work required under this Section and the Contractor shall include all costs thereof in its lump sum price bid for the Contract.

1.03 RELATED SECTIONS

- A. General Specification 02316 -- Excavation
- B. General Specification 02317 -- Backfilling
- C. General Specification 02371 -- Dust, Soil Erosion and Sedimentation Control
- D. General Specification 02910 -- Planting
- E. General Specification 02920 -- Soil Mixes

1.04 REFERENCES

- A. Federal regulations, 7 CFR 301.51- Asian Longhorned Beetle
- B. NYCRR Title 1 Part 139 – Control of the Asian Long Horned Beetle
- C. NYCRR Title 1 Part 141 – Control of the Emerald Ash Borer
- D. Federal regulations, 7 CFR 301.53 – Emerald Ash Borer

1.05 DEFINITIONS & EXPLANATIONS

- A. Asian Longhorned Beetle (ALB): The insect known as the Asian Longhorned Beetle (*Anoplophora glabripennis*) in any stage of development.
- B. ALB Compliance Agreement: A written agreement between United States Department of Agriculture (USDA) Animal and Plant Health Inspection Service (APHIS) and a person engaged in growing, handling, or moving regulated articles that are moved within an ALB Quarantine Zone, in which the person agrees to comply with the provisions of 7 CFR 301.51.
- C. ALB Limited Permit: A document in which a USDA APHIS inspector affirms that the ALB Regulated Article is eligible for movement only to a specified destination and in accordance with conditions specified on the permit.
- D. ALB Regulated Article: The term applies to: (1) Firewood (all hardwood species), and green lumber and other material living, dead, cut or fallen, inclusive of nursery stock, logs, stumps, roots, branches, and



## GENERAL SPECIFICATION 02230 SITE CLEARING

---

debris of half an inch or more in diameter of the following genera: Acer (maple), Aesculus (horse chestnut), Albizia (mimosa), Betula (birch), Celtis (hackberry), Cercidiphyllum (katsura), Fraxinus (ash), Platanus (sycamore), Populus (poplar), Salix (willow), Sorbus (mountain ash), and Ulmus (elm); (2) Any other article, product, or means of conveyance not covered in (1) of this definition if a USDA APHIS inspector determines that it presents a risk of spreading Asian Longhorned Beetle and notifies the person in possession of the article, product, or means of conveyance that it is subject to the restrictions of 7 CFR 301.51. This definition is subject to change and should be verified by consulting 7 CFR 301.51 prior to the start of work.

- E. Caliper: An instrument used to measure the diameter of a tree.
- F. Clearing: Clearing is the removal from the ground surface within the designated areas and disposal of trees, brush, shrubs, down timber, decayed wood, other vegetation, rubbish, trash, scrap metal, debris and miscellaneous other structures not covered under other Sections as shown on the Contract Drawings, specified or otherwise required to permit construction of the new Work.
- G. Emerald Ash Borer (EAB): The insect known as the Emerald Ash Borer in any stage of development.
- H. EAB Compliance Agreement: An approved document, executed by persons or firms, covering the restricted movement, processing, handling or utilization of regulated articles not eligible for certification for intrastate movement. USDA APHIS controls the issuance of EAB Compliance Agreements for movement of regulated articles interstate. For movement of regulated articles intrastate, New York State Department of Agriculture and Markets (NYSDAM) controls the issuance of EAB Compliance Agreements.
- I. EAB Regulated Article: The term applies to: (1) entire ash trees of any size, inclusive of nursery stock; (2) any part of ash trees, including leaves, bark, stumps, limbs, branches, and roots (i.e., living, dead, cut or fallen); (3) ash lumber or ash logs of any length; (4) any item made from or containing ash wood; (5) any article, product or means of conveyance determined by the USDA APHIS, NYSDAM or New York State Department of Environmental Conservation (NYSDEC) to present risk of spreading the EAB infestation; (6) firewood from any tree species; and, (7) wood chips and bark mulch from any tree species, larger than 1 inch in two dimensions, whether composted or uncomposted. This definition is subject to change. The relevant EAB Quarantine Order should be consulted for the current definition.
- J. Grubbing: Grubbing is the removal and disposal of all stumps, buried logs, roots larger than 2 inches, matted roots and organic materials.

## GENERAL SPECIFICATION 02230 SITE CLEARING

---

### 1.06 QUALITY ASSURANCE

- A. Codes and Standards: State and local laws and code requirements shall govern the hauling and disposal of trees, shrubs, stumps, roots, rubbish, debris and other matter.
- B. The Contractor or subcontractor responsible for work of any kind affecting EAB Regulated Articles within the Emerald Ash Borer Quarantine Zone must have EAB First Detectors training as certified by Cornell Cooperative Extension, or an approved equal. Work includes, but is not limited to planting trees, transplanting trees, pruning trees, fertilizing trees, removing trees and stumps, and clearing and grubbing trees or roots.
- C. The Contractor or subcontractor responsible for work of any kind affecting ALB Regulated Articles within the Asian Longhorned Beetle Quarantine Zone must have an ALB Compliance Agreement. Work includes, but is not limited to planting trees, transplanting trees, pruning trees, fertilizing trees, removing trees and stumps, and clearing and grubbing trees or roots.

### 1.07 PROJECT/SITE CONDITIONS

- A. Streets, roads, adjacent property and other works and structures shall be protected throughout the entire project. Contractor shall return to original condition, satisfactory to the Engineer, facilities damaged by the Contractor's operations.
- B. If the project site is in an Emerald Ash Borer Quarantine Zone established by the NYSDEC and NYSDAM, New York State prohibits the movement of regulated articles beyond the quarantined counties without an EAB Compliance Agreement.
- C. If the project site is in an Asian Longhorned Beetle Quarantine Zone, USDA APHIS prohibits the movement of regulated articles beyond the quarantine zone without an ALB Compliance Agreement.

### 1.08 GUARANTEE

- A. The Contractor shall guarantee that work performed under this Section will not permanently damage trees, shrubs, turf or plants designated to remain, or other adjacent work or facilities. If damage resulting from Contractor's operations appears during the period up to 12 months after completion of the project, he shall replace damaged items as directed by DEP at no expense to the City to the satisfaction of the DEP.

### 1.09 SUBMITTALS

- A. Contractor shall submit Shop Drawings and material specifications for the approval of the Engineer. Shop Drawings shall identify all trees designated for removal and those that shall remain and require protection, as directed by the Engineer.

**B. Tree Protection Plan**

1. The Contractor shall submit a Tree Protection Plan to the Engineer for approval prior to performing any work on trees or shrubs to be saved or in the vicinity of such trees and shrubs. The Plan must be approved prior to any such work being performed.
  - a. The Plan shall be prepared in consultation with the Engineer.
    - 1) The Plan should include, but not necessarily be limited to, the location of temporary wooden tree guards, construction fence, temporary snow fence boundary, range fencing, micro tunneling, soil erosion and sediment control, hand and/or pneumatic excavation, soil compaction prevention and mitigation requirements, impact of trenching and/or cut and fill operations and pruning and fertilization schedule. Soil testing and fertilization schedule, as well as other applicable methods of tree protection shall be as required by General Specification 02920 - Soil Mixes and the Detailed Specifications.
    - 2) In addition, the Plan should address the Contractor's operations, including designated staging areas, site access and stockpiling of materials.
    - 3) Mandatory provisions of the Plan always include, but are not limited to, the following provisions:
      - a) The Contractor shall not be permitted to park vehicles or equipment or to stockpile materials of any nature under the drip line of trees and shrubs in order to minimize surface and subsurface root damage and soil compaction. This directive shall apply to all areas within or outside the contract limit line.

**C. Emerald Ash Borer Management Plan**

1. Each Contractor responsible for site clearing and grubbing shall submit an EAB Management Plan to the Engineer for approval prior to removal of any trees or vegetation from the construction site. The Plan shall identify each work site and all transportation routes, haulers, processing and disposal facilities including full contact information. The Plan shall confirm whether any debris will be generated, transported, processed or disposed in an EAB Quarantine Zone. If the construction site, transportation routes, processing and disposal facilities are not within an EAB Quarantine Zone, no further details are required in the Plan.

## GENERAL SPECIFICATION 02230 SITE CLEARING

---

2. If EAB Regulated Articles are generated at a site that is not located within an EAB Quarantine Zone, but the materials will be transported into or through a Quarantine Zone for processing or disposal, the Plan shall also include:
  - a. A copy of the EAB Compliance Agreement for the transportation of EAB Regulated Articles into or through an EAB Quarantine Zone.
3. If the site is located within an EAB Quarantine Zone, the Plan shall also include the following:
  - a. A description of the survey methods to identify any EAB infestation and EAB Regulated Articles. The survey shall be performed by a professional in possession of a Cornell Cooperative Extension EAB First Detectors Certificate, or an approved equal, and shall be performed after felling trees and prior to removing any EAB Regulated Articles from the site. Evidence of certification shall be provided in the Plan. The results of the survey shall be summarized in an EAB survey report and provided to the Engineer prior to removing any EAB Regulated Articles from the site.
  - b. Provisions for notifying the Engineer and a NYSDAM horticultural inspector immediately upon the discovery of an EAB infestation. If an EAB infestation is confirmed by NYSDAM, the Contractor will be required to enter into an EAB Compliance Agreement. The EAB Compliance Agreement will dictate how the EAB and Regulated Articles must be managed and treated prior to removal from the site.
4. Unless the survey report specifically confirms the absence of ash trees (*Fraxinus* spp.), the Plan shall also include the following:
  - a. Schedule for conducting activities affected by EAB Regulated Articles
  - b. Identification and anticipated quantity of EAB Regulated Articles and proposed handling methods.
    - 1) If the EAB Regulated Articles are destined for a processing facility, the facility shall identify whether the materials will be recycled for resale or disposed
    - 2) If the EAB Regulated Articles are to be processed for resale by the Contractor, Subcontractor or processing facility, the Plan shall include a copy of the facility's EAB Compliance Agreement for handling Regulated Articles.

## GENERAL SPECIFICATION 02230 SITE CLEARING

---

3) If the EAB Regulated Articles are to be transported out of the EAB Quarantine Zone, a copy of the Contractor's EAB Compliance Agreement for transporting Regulated Articles out of an EAB Quarantine Zone shall be included in the Plan.

c. Storage location for EAB Regulated Articles

d. Treatment methods if the Contractor elects to treat EAB Regulated Articles onsite such that they are no longer regulated. Onsite treatment requires that the responsible party be in possession of a Cornell Cooperative Extension EAB First Detectors Certificate, or an approved equal, and requires coordination with NYSDAM for inspection and verification. Evidence of the responsible party's certification shall be provided in the Plan.

e. Protocol for tracking the shipment of EAB Regulated Articles using a bill of lading or manifest that identifies the site, transporter, truck identification number and provides for signature upon receipt at the Processing or Disposal Facility. Payment of the removal of EAB Regulated Articles will not be made until signed copies of the bill of lading or manifest are provided to the Engineer.

### D. EAB Survey Report

1. Each Contractor responsible for site clearing and grubbing within an EAB Quarantine Zone is required to have the site surveyed for the presence of EAB by a professional in possession of a Cornell Cooperative Extension EAB First Detectors Certificate, or an approved equal. The Contractor shall submit an EAB Survey Report to the Engineer within two weeks of survey completion. Regulated Articles may not be moved offsite without Engineer approval of the EAB Survey Report. The EAB Survey Report shall be signed by the certified professional and shall include documentation of the surveyor's credentials.

### E. Asian Longhorned Beetle Management Plan

1. Each Contractor responsible for site clearing and grubbing shall submit an ALB Management Plan to the Engineer for approval prior to removal of any trees or vegetation from the construction site. The Plan shall identify each work site and all transportation routes, haulers, processing and disposal facilities including full contact information. The Plan shall confirm whether any debris will be generated, transported, processed or disposed in an ALB Quarantine Zone. If the construction site,

## GENERAL SPECIFICATION 02230 SITE CLEARING

---

transportation routes, processing and disposal facilities are not within an ALB Quarantine Zone, no further details are required in the Plan.

2. If ALB Regulated Articles are generated at a site that is not located within an ALB Quarantine Zone, but the materials will be transported into or through a quarantine zone for processing or disposal, the Plan shall also include:
  - a. For Interstate Movement - A copy of the ALB Limited Permit authorizing such movement or specific procedures for ensuring compliance with 7 CFR 301.51-4 which regulates the movement of Regulated Articles.
  - b. For Intrastate Movement - Identification of the origin and destination of the regulated article in accordance with NYCRR Title 1 Part 139.
  - c. A copy of the processing or disposal facility's ALB Compliance Agreement.
3. If the site is located within an ALB Quarantine Zone, the Plan shall also include the following:
  - a. A copy of the Contractor's ALB Compliance Agreement with USDA APHIS.
  - b. A description of the survey methods to identify any ALB infestation and ALB Regulated Articles. The survey shall be performed by a professional in possession of an ALB Compliance Agreement, and shall be performed prior to felling trees and removing any ALB Regulated Articles from the site. Evidence of the professional's ALB Compliance Agreement shall be provided in the Plan. The results of the survey shall be summarized in an ALB survey report and provided to the Engineer prior to removing any ALB Regulated Articles from the site.
  - c. Provisions for notifying the Engineer and a USDA APHIS inspector immediately upon the discovery of an ALB infestation. If an ALB infestation is discovered, the Contractor shall stop all site clearing and grubbing until permission to resume work has been given in writing by a USDA APHIS Inspector. A copy of the permission to resume work shall be provided to the Engineer.
4. Unless the survey report specifically confirms the absence of Regulated Articles, the Plan shall also include the following:
  - a. Schedule for conducting activities affected by ALB Regulated Articles

- b. Identification and anticipated quantity of ALB Regulated Articles and proposed handling methods.
  - 1) If the ALB Regulated Articles are destined for a processing facility, the facility shall be in possession of an ALB Compliance Agreement. The Plan shall include a copy of the facility's ALB Compliance Agreement for handling Regulated Articles.
  - 2) If the ALB Regulated Articles are to be transported out of the ALB Quarantine Zone, a copy of the Contractor's ALB Compliance Agreement for transporting Regulated Articles out of an ALB Quarantine Zone shall be included in the Plan.
- c. Storage location for ALB Regulated Articles
- d. Treatment methods if the Contractor elects to treat ALB Regulated Articles onsite such that they are no longer regulated. Onsite treatment requires that the responsible party be in possession of an ALB Compliance Agreement and requires coordination with USDA APHIS or a professional in possession of an ALB Compliance Agreement with USDA APHIS for inspection and verification. A copy of the responsible party's ALB Compliance Agreement shall be provided in the Plan.
- e. Protocol for tracking the shipment of ALB Regulated Articles using a bill of lading or manifest that identifies the site, transporter, truck identification number and provides for signature upon receipt at the processing or disposal facility. Payment of the removal of ALB Regulated Articles will not be made until signed copies of the bill of lading or manifest are provided to the Engineer.

F. ALB Survey Report

- 1. Each Contractor responsible for site clearing and grubbing within an ALB Quarantine Zone is required to have the site surveyed for the presence of ALB by a professional in possession of an ALB Compliance Agreement. The Contractor shall submit an ALB Survey Report to the Engineer within two weeks of survey completion. Regulated Articles may not be moved offsite without Engineer approval of the ALB Survey Report. The ALB Survey Report shall be signed by the professional and shall include a copy of the surveyor's ALB Compliance Agreement.

## GENERAL SPECIFICATION 02230 SITE CLEARING

---

### PART 2 PRODUCTS (NOT USED)

### PART 3 EXECUTION

#### 3.01 TREES AND SHRUBS TO BE SAVED

- A. Protection: The Contractor shall protect from defacement, injury and destruction all trees and shrubs within the construction site that are so delineated or are marked in the field to be saved. Trees, shrubs and grassed areas which are to remain shall be protected by fences, barricades, wrapping or other methods as shown on the Contract Drawings, specified or approved by the Engineer.
1. Within the limits of the area from the tree trunk up to 3 to 4 feet outside of the tree drip line, work shall be performed with extreme care using either hand tools or equipment that will not cause damage to trees.
    - a. Do not disturb or cut roots unnecessarily. Do not cut roots 2 inches and larger unless approved.
    - b. Immediately backfill around tree roots after completion of construction in the vicinity of trees.
    - c. Do not operate any wheeled or tracked equipment within drip line.
  2. Vegetation shall be protected from damage caused by emissions from engine-powered equipment.
  3. During working operations, the trunk, foliage and root system of all trees to be saved shall be protected with boards or other guards placed as shown on the Contract Drawings and as required to prevent damage, injury and defacement.
    - a. Excavated materials shall not be piled within the drip line or adjacent to the trunks of trees. Equipment, stockpiles, etc. shall not be permitted within the drip line.
    - b. Do not allow runoff to accumulate around trunks of trees.
    - c. Ropes, cables, or guy wires shall not be fastened or attached to trees without permission. When such permission is granted, protect the tree before making fastening or attachments by providing burlap wrapping and softwood cleats.
    - d. The use of axes or climbing spurs for trimming will not be permitted.
    - e. Provide climbing ropes during trimming.
  4. When directed by the Engineer, shrubs to be saved shall be removed by taking a sufficient earth ball with the roots to maintain the shrub.



## GENERAL SPECIFICATION 02230 SITE CLEARING

---

- a. Temporarily replant, if required, and replace at the completion of construction in a condition equaling that which existed prior to removal.
  - b. Replace in kind if the transplant fails. Provide transplanting, planting, and watering and guarantee as specified in General Specification 02910 - Planting.
5. When directed by the Engineer, emergency repair to damaged trees and to trees which pose an imminent danger shall be performed within 24 hours.
6. Damage Assessment
  - a. Tree damage. For trees that are damaged during the course of construction, a monetary credit shall be taken. The monetary assessment shall be the difference between the tree's condition rating, as per the International Society of Arboriculture appraisal method, before and after the damage. The damage assessment shall be determined by the Engineer.
  - b. Tree Destruction. Any trees irreparably damaged during the course of construction, as determined by the Engineer shall be removed at the Contractor's sole expense. Restitution shall be made according to the Caliper Area Replacement formula, as determined by the Engineer. Restitution can be met by the Contractor through the following options:
    - 1) Direct planting by the Contractor or its subcontractor of the required equivalent number of replacement trees at locations determined by the Engineer; or
    - 2) A monetary credit for the value of the tree destroyed; or
    - 3) A combination of (1) and (2) above, as determined by the Engineer. If the Contractor plants some replacement trees, a monetary credit shall be taken for the difference between the full value of the destroyed tree and the value of the number of replacement trees planted.
  - c. Tree Removal. Restitution for any prohibited tree removals shall be made according to the Caliper Area Replacement formula, with adjustments for tree condition as per the International Society of Arboriculture appraisal method, as determined by the Engineer.

## GENERAL SPECIFICATION 02230 SITE CLEARING

---

### 3.02 REMOVAL OF TREES AND SHRUBS

#### A. Tree Removal within Property Limits:

1. Only those trees designated on the Contract Drawings for removal shall be removed.
2. Tree and shrub removal shall be conducted in a manner so as to avoid damage to those trees and shrubs which will remain.
3. Do not cut or damage trees or shrubs outside of the Contract limit lines. Damage outside the Contract limit lines caused by the Contractor's operations shall be corrected at the Contractor's expense.
4. The removal of trees with calipers 6 inches or less shall be included in the costs for the work of this Section. Payment for removal of trees greater than 6 inches shall be paid under individual unit price items specified in the Detailed Specifications using the following parameters:
  - a. Over 6" to 12"
  - b. Over 12" to 18"
  - c. Over 18" to 24"
  - d. Over 24"
5. All trees shall be calipered at four and one-half feet above existing grade prior to removal. All trees shall be "topped" and "limbed" previous to felling unless otherwise directed by the Engineer.
6. In areas of major construction, the stumps and roots of all trees designated for removal shall be grubbed and excavated to a depth of three (3) feet below the ground surface except in areas of fill greater than three (3) feet, where such trees may be cut flush with the ground surface.

### 3.03 CERTIFIED ARBORIST

- A. All tree pruning, tree repair, and tree removal is to be performed by competent workers only, under the supervision of an arborist holding certification from the International Society of Arboriculture (ISA), or registered with the American Society of Consulting Arborists or equivalent education and experience.

### 3.04 EMERALD ASH BORER QUARANTINE ZONE

- A. The EAB is a destructive wood boring insect that solely infests ash (*Fraxinus* spp.) trees and has killed tens of millions of trees across the US. EAB feed upon the cambium and phloem and kill a tree within two years. From a seedling to full grown trees, all parts of an ash tree are subject to infestation. In an effort to control the spread of EAB to other areas, quarantine orders have been imposed on a number of counties within New York State. A current

## GENERAL SPECIFICATION 02230 SITE CLEARING

---

map of the geographic area included in the quarantine zones within New York State is available at the following website:

<http://www.dec.ny.gov/animals/47761.html>.

- B. Any Contractor and Subcontractor performing tree work of any kind within the EAB Quarantine Zone shall be in compliance with the relevant NYSDEC Quarantine Order. Tree work includes, but is not limited to planting trees, transplanting trees, pruning and fertilizing trees, removing trees and stumps, and clearing and grubbing trees or roots.

### 3.05 ASIAN LONGHORNED BEETLE QUARANTINE ZONE

- A. The Asian Longhorned Beetle (ALB) is a destructive wood boring insect. It can cause serious damage to healthy trees by boring into their heartwood and eventually killing them. Nursery stock, logs, green lumber, firewood, stumps, roots, branches and debris of one-half (½") inch or more in diameter are subject to infestation. In an effort to control the spread of the beetle to other areas, a quarantine has been imposed by USDA APHIS on large portions of the City of New York as per Part 139 of Title 1 NYCRR.

- B. Any Contractor or subcontractor performing tree work of any kind within the ALB Quarantine Zone must have an ALB Compliance Agreement, and will be held responsible for compliance with USDA APHIS. Tree work includes, but is not limited to planting trees, transplanting trees, pruning and fertilizing trees, removing trees and stumps, and clearing and grubbing trees or roots.

- 1. A current map of the geographic area included in the ALB Quarantine Zone within New York City is available at the following website:  
[https://www.aphis.usda.gov/aphis/ourfocus/planthealth/plant-pest-and-disease-programs/pests-and-diseases/asian-longhorned-beetle/ct\\_alb\\_maps](https://www.aphis.usda.gov/aphis/ourfocus/planthealth/plant-pest-and-disease-programs/pests-and-diseases/asian-longhorned-beetle/ct_alb_maps)

- 2. Additional information is available at the following website:  
<http://www.agriculture.ny.gov/PI/alb.html>

### 3.06 CLEARING AND GRUBBING

- A. Clearing: The Contractor shall clear all items specified to the Contract limit lines shown on the Contract Drawings and shall remove cleared and grubbed materials from the site to an authorized disposal site.

- 1. Do not start earthwork operations in areas where clearing and grubbing is not complete, except that stumps and large roots may be removed concurrent with excavation.

- 2. Comply with erosion, sediment control and storm management measures as specified in General Specification 02371 - Dust, Soil Erosion and Sedimentation Control.

## GENERAL SPECIFICATION 02230 SITE CLEARING

---

- B. Grubbing: The Contractor shall clear and grub areas to be excavated, areas receiving less than 3 feet of fill and areas upon which structures are to be constructed.
    - 1. Stumps and root mats in these areas shall be removed to a depth of not less than 1 foot below the subgrade of sloped surfaces.
    - 2. All depressions made by the removal of stumps or roots shall be filled with material suitable for backfill as specified in General Specification 02317 - Backfilling.
  - C. Limited Clearing: The Contractor shall clear areas receiving more than 3 feet of fill by cutting trees and shrubs as close as practical to the existing ground. Grubbing will not be required.
  - D. Disposal:
    - 1. All disposals off-site shall be in complete accordance with rules and regulations of the authorities having jurisdiction.
    - 2. Burning of cleared and grubbed materials is not allowed within the property limits.
  - E. Explosives shall not be used.
  - F. No cleared or grubbed material may be used in backfills or structural embankments.
  - G. Cleared and grubbed items shall be removed from the site and disposed of in accordance with the applicable regulations and requirements of this Contract.
  - H. Air pollution caused by dust and dirt shall be controlled, complying with governing regulations. Dust control shall be as specified in General Specification 02371 – Dust, Soil Erosion and Sedimentation Control.
- 3.07 STRIPPING TOPSOIL
- A. The Contractor shall strip existing topsoil as described in General Specification 02316 - Excavation. Heavy growths of grass shall be removed from areas before stripping the topsoil.

END OF SECTION

**SECTION 02240  
Dewatering**

**PART 1 GENERAL**

**1.01 SECTION INCLUDES**

- A. The Contractor shall furnish, install, operate and maintain dewatering equipment and systems as specified, shown on the Contract Drawings, or required during the Contract.
- B. The Contractor shall provide standby equipment and power supply for maintaining uninterrupted construction dewatering.
- C. The Contractor shall install groundwater monitoring wells/piezometers and measure, record and report the levels/hydraulic head of groundwater as required during the project.
- D. The Contractor shall obtain and comply with all necessary permits from State and local agencies required for operation of the dewatering system, monitoring groundwater, and disposal of dewatering effluent.
- E. The Contractor shall collect samples of the dewatering effluent as required by the applicable State and local permits and provide the services of a laboratory certified under the New York State Department of Health (NYSDOH) Environmental Laboratory Approval Program (ELAP) for the analyses of the samples collected to determine the quality of dewatering effluent prior to disposal.
- F. The following index of this Section is included for convenience:

<u>Article</u>	<u>Title</u>	<u>Page</u>
		02240-
PART 1	GENERAL.....	1
1.01	Section Includes.....	1
1.02	Payment.....	2
1.03	Related Sections.....	2
1.04	References.....	2
1.05	Definitions.....	2
1.06	Submittals.....	3
1.07	Quality Assurance.....	5
1.08	Design Requirements.....	5
1.09	Regulatory Requirements.....	6
PART 2	PRODUCTS.....	7
2.01	Materials And Equipment.....	7
PART 3	EXECUTION.....	7
3.01	General Requirements.....	7

## GENERAL SPECIFICATION 02240 – DEWATERING

---

3.02	Testing.....	8
3.03	Installation And Operation.....	8
3.04	Surface Water.....	9
3.05	Pretreatment Of Dewatering Effluent.....	10
3.06	Disposal Of Dewatering Effluent.....	11
1.02	PAYMENT	
A.	Unless otherwise provided in the Detailed Specifications, no separate payment will be made for performing any Work required under this Section and the Contractor shall include all costs thereof in its lump sum price bid for the Contract.	
1.03	RELATED SECTIONS	
A.	General Specification 02105 - Soil Sampling and Analysis	
B.	General Specification 02316 - Excavation	
C.	General Specification 02371 - Dust, Soil Erosion and Sedimentation Control	
1.04	REFERENCES	
A.	6 NYCRR Part 750, State Pollutant Discharge Elimination System (SPDES) Permits	
B.	6 NYCRR Part 601, Water Withdrawal Permitting, Reporting and Registration (Exclusive of Long Island Wells Regulated Under Part 602 of This Title)	
C.	6 NYCRR Part 602, Applications for Long Island Wells	
D.	6 NYCRR Part 621, Uniform Procedures	
E.	Water and Sewer Forms, New York City Department of Environmental Protection; ( <a href="http://www.nyc.gov/html/dep/html/forms_and_permits/wsforms.shtml">http://www.nyc.gov/html/dep/html/forms_and_permits/wsforms.shtml</a> )	
F.	New York City Construction Code	
G.	ASTM standards applicable to piping, equipment and other items required for a complete dewatering system	
1.05	DEFINITIONS	
A.	<u>Construction Dewatering</u> : Controlling groundwater levels, hydrostatic pressures and controlling surface water, such that excavation required on the Contract Drawings can be performed to required depths in substantially dry and stable conditions.	
B.	<u>Dewatering System</u> : System of wells, well points, sumps, ejectors, pumps, piping, power supply, effluent treatment equipment and other equipment	

designed by the Contractor, submitted to and approved by the Engineer prior to dewatering, that will effectively dewater the site as required herein and as specified in the Detailed Specifications. Adequate monitoring wells/piezometers shall be included in the dewatering system to verify drawdown levels inside the excavation area and monitor groundwater levels outside the limits of the excavation near adjacent structures.

1.06 SUBMITTALS

A. The Contractor shall submit Shop Drawings and the following for the approval of the Engineer:

1. Pre-construction Submittals: A Dewatering Plan shall be submitted to the Engineer for approval, at least 30 calendar days prior to the scheduled date for commencement of the dewatering Work, and to the NYSDEC, as applicable. Approval of the Dewatering Plan by the Engineer or City shall not in any way relieve the Contractor from full responsibility for the complete and adequate design and performance of the dewatering system to provide the necessary construction dewatering. At a minimum, the Dewatering Plan shall include the following:
  - a. Design calculations confirming the adequacy of the proposed dewatering system, including depths to groundwater within the excavation limits.
  - b. Calculations and requisite technical data on well screens and filter materials and gradations to demonstrate the adequacy of proposed systems to prevent the pumping of fines.
  - c. Shop drawings showing the proposed types and planned locations of surface water control and the dewatering system to be used.
  - d. Shop drawings shall include the arrangements, locations and depths of the dewatering system, a complete description of equipment and materials to be used and the procedures to be followed in installation, operation and maintenance in relation to the proposed sequence of excavation, foundation construction and backfilling.
  - e. The standby equipment and standby power supply details.
  - f. The proposed locations and sizes of effluent treatment equipment, effluent flow equalization tanks and discharge of water.
  - g. Location and size of sumps, ditches and water discharge lines, including their relation to water disposal points.

## GENERAL SPECIFICATION 02240 – DEWATERING

---

- h. Submittals shall also include discharge details, metering, and monitoring schedules and the details of the settling tank and oil/water separator.
  - i. Methods and equipment to be used for drilling, construction, and development of wells and piezometers.
  - j. Protocols to be followed for the sampling and analysis of dewatering effluent, and the name and qualifications of the laboratory that will be testing the quality of dewatering effluent prior to disposal.
  - k. Protocols to be followed for treatment of effluent in conformance with the requirements of the applicable permits.
2. As required in Section 02105 -- Soil Sampling and Analysis, the Contractor shall submit a completed EH&S Drilling and Boring Checklist for approval to the Engineer
3. As-built Submittals: Prior to the start of construction dewatering, submit as-built conditions of the dewatering system. As-built data are to include but are not limited to:
- a. Plans and sections showing as-built locations, and surveyed elevations of the dewatering system and its components.
  - b. Drawings to indicate changes made to the original shop drawings to accommodate field conditions and to comply with design standards.
  - c. Details of installation including dimensions and materials used, description and drawings of all installations, all procedures, soil strata encountered and logs with descriptions of soil samples and stratification.
  - d. Details of each sump, well, well point, observation well, and piezometer installed, including, but not limited to, the diameters of the borehole and the components, screen type, screen opening size, screen top and bottom elevations, details of filter, seal and grout, pump type, and capacity if installed within. These details should be provided to the Engineer within a week of installation of each entity. The details shall be re-submitted if any part of the entity changes during construction.
  - e. Details of abandoning each sump, well, well point, observation well, and piezometer after its use has been completed.
4. Regulatory Compliance: Prior to the start of construction dewatering, submit a report comparing site groundwater quality data with the water quality standards to be complied with under permit(s) as applicable to



the project or required in the Detailed Specifications. The permitting requirements to be considered under the Work of this section include, but may not be limited to:

- a. NYCDEP Dewatering Permit for temporary groundwater discharge into the public sewers of the City.
  - 1) Wastewater Quality Control Application and Letter of Approval, if applicable, from the Inspection & Permitting Section, Industrial Pollution Prevention (IPP) Program, Division of Pollution Control and Monitoring, Bureau of Wastewater Treatment (BWT).
  - 2) Letter of Approval from the Division of Connection and Permitting, Bureau of Water & Sewer Operations (BWSO), if applicable.
  - 3) NYC DEP Bureau of Customer Service Permit
- b. NYSDEC SPDES Discharge Permit(s) - General or Individual Permits - for dewatering effluent or storm water discharges from construction activities at the project site.
- c. Water Supply and Long Island Well Permits, if applicable, in association with construction dewatering.
- d. The Contractor shall be responsible for compliance with all dewatering permit requirements including renewals once construction dewatering begins.

1.07 QUALITY ASSURANCE

- A. The dewatering Work shall be performed by an entity specializing in and having experience installing and operating dewatering systems in similar subsurface conditions for at least 5 years.
- B. Dewatering system shall be designed by a Professional Engineer registered in the State of New York having experience in designing a system in similar site conditions.
- C. Well drillers shall be licensed in the State of New York.

1.08 DESIGN REQUIREMENTS

- A. The Contractor shall design, install, operate, maintain and remove the dewatering system as necessary to:
  1. Lower and maintain groundwater levels and hydrostatic pressures to 2 feet below the prevailing excavation level or to a point no higher than 2 feet above the top of an impermeable stratum, if the subgrade is in the impermeable stratum. Groundwater levels shall be lowered for a time

period as deemed necessary by the Engineer to ensure adequate factor of safety for the constructed structure.

2. Maintain stable slopes and subgrade.
  3. Control and remove seepage and surface water into excavations.
  4. Allow subsequent work to be safely performed and not result in damage to adjacent properties, buildings, structures, utilities and other work.
  5. The Contractor shall provide primary and standby power, including all costs for installation, energy and fuel.
  6. The Engineer will perform inspections and witnessing of:
    - a. Testing of sand and silt from dewatering wells.
    - b. Drawdown and performance testing of Dewatering System.
    - c. Performance testing of standby power source and backup Dewatering System.
- B. The method of dewatering and control of water both inside and outside the excavation shall be selected by the Contractor who shall be solely responsible for the location, arrangement and depth of any system(s) selected to accomplish the Work. The Contractor shall construct protective works as necessary to dewater, cut off porous zones of fill and direct the flow of water from whatever source away from the excavations and adjacent areas. Protective works shall include slurry methods, grouting, clay seepage plugs, toe drains with appropriate filters, deep wells, well points, sumps, dikes, ditches and all supporting features as required, but not specifically shown on the Contract Drawings.
1. The dewatering system shall be designed and implemented so as to maintain a minimum factor of safety against the uplift groundwater pressures in any soil strata. The factor of safety shall be calculated by considering the stabilizing pressure to consist of overburden soil weight alone. The dewatering system shall be maintained operational until the dead weight of the overburden soil plus any completed portion of the structure is able to provide the required factor of safety at static (normal) groundwater level / pressure.

#### 1.09 REGULATORY REQUIREMENTS

- A. The Contractor shall manage and dispose of all groundwater removed during dewatering activities in accordance with either New York State Pollutant Discharge Elimination System (SPDES) standards set by the New York State DEC for discharge to surface water, or New York City DEP Sewer Discharge Criteria for discharge to the City wastewater collection system. The Contractor shall acquire all necessary permits and/or applications for disposal of dewatering effluent.

- B. For discharge to the City wastewater collection system, a comparison of the site groundwater quality data (before and after any treatment proposed by the Contractor) with the NYCDEP Limitations for Effluent to Sanitary or Combined Sewers (latest version issued by the Division of Pollution Control and Monitoring, Bureau of Wastewater Treatment) shall be required prior to and during effluent discharge.

**PART 2 PRODUCTS**

**2.01 MATERIALS AND EQUIPMENT**

- A. Materials and equipment used in the dewatering system shall adhere to accepted industry standards and be in good operating condition and able to perform satisfactorily over the required duration of construction dewatering.
- B. Back up equipment for the dewatering system shall be identical to the primary equipment and shall be available in operating condition at all times.
- C. Pipes and well screens shall consist of Schedule 40 PVC or stronger.
- D. Sand shall consist of clean, single-size filter sand of adequate gradation.
- E. Grout shall consist of cement-bentonite grout of adequate mix proportion and consistency. Seals shall consist of bentonite pellets.
- F. Pumps, meters, hoses and controls shall be suitable for the intended purpose and application.
- G. Power supply and effluent discharge are included in this Work.

**PART 3 EXECUTION**

**3.01 GENERAL REQUIREMENTS**

- A. Construction dewatering is required to protect foundation subgrades and to maintain dry and stable conditions for construction. The Contractor shall maintain a continuous and completely effective Dewatering System for the required time as specified in General Specification 02316 -- Excavation.
- B. The Contractor shall contact the NYSDEC to obtain SPDES permit(s), if necessary, sufficiently in advance of dewatering system startup. The Contractor shall also keep the SPDES permits active by applying for and following up on the applications for modifying or renewing the permits, if necessary, during the period of performance.
- C. The Contractor shall coordinate the operation of the dewatering system with any other Work.
- D. The Contractor shall be prepared to modify the dewatering system and methods as required by actual field conditions encountered during construction, at no additional cost to the City. Any component of the dewatering system that

malfunctions or is damaged during its operation shall be promptly repaired or replaced by the Contractor at no additional cost to the City.

- E. The Contractor shall measure water levels periodically in observation wells / piezometers installed adjacent to nearby structures to ensure drawdown outside the excavation is within permissible limits specified in the Detailed Specifications.
- F. Surface areas adjacent to the excavation shall be graded and/or curbed to prevent flow of surface water into the excavation.
- G. The Contractor shall install observation wells / piezometers and monitor groundwater lowering at nearby structures due to construction dewatering. Any damage caused to nearby structures due to construction dewatering shall be repaired by the Contractor at no cost to the City.

3.02 TESTING

- A. The Contractor is responsible for monitoring dewatering efforts to determine if the Contract and related permit requirements are being met. The Contractor shall provide observation wells and other means to monitor the dewatering as detailed in the Dewatering Plan.
- B. The Contractor shall determine the presence of contaminants in dewatering effluent, including the quantity of fines in the pumped water, by sampling and analyzing in accordance with permit requirements, or once every two weeks, whichever is more frequent.
- C. The fines content should be measured in each sump, well or well point being pumped. The permissible maximum fines content is 5 parts per million (ppm) as measured by the Rossum Sand Content tester. If the fines content is exceeded, the Contractor shall modify or re-install the well or wellpoint to satisfy the requirements.

3.03 INSTALLATION AND OPERATION

- A. The dewatering system shall provide for an uninterrupted flow of pumped water and shall be maintained and pumped as necessary to drawdown and maintain the groundwater levels as specified. Unless otherwise specified, pumping shall maintain those depressed levels until the permanent under drainage system has been installed, tested, accepted and is operational or until the permanent structure, or a portion thereof, is capable of withstanding hydrostatic pressures as determined by the Engineer.
- B. The Contractor shall furnish, operate and maintain sufficient drainage and pumping facilities to dewater the site and its underlying soil. Dewatering operations shall operate in such a manner so that the excavation can proceed while maintaining stable slopes and the designed lateral support for the perimeter support of excavation walls, without disturbing the bearing subgrades for the structure and provide stable conditions. The ground water level as

measured in observation wells shall be lowered and maintained at least two feet below the prevailing excavation level, or it shall be lowered to a point no higher than 2 feet above the top of impermeable stratum if the subgrade is in the impermeable stratum.

- C. The dewatering system shall be installed and operated in such a manner as to avoid the movement of fines or loss of ground below the bearing level and shall not influence the stability of surrounding areas. Well points and deep wells shall be properly sanded in and sumps shall be sheeted and provided with proper filter material.
- D. A sufficient number of observation wells shall be installed and water levels monitored by the Contractor, at least weekly, to demonstrate that the goals of the Dewatering System are being met. If applicable, the Contractor may make use of existing observation wells as shown on the Contract Drawings.
- E. Open pumping with sumps and ditches resulting in boils, loss of fines, softening of the ground or instability of slopes will not be permitted.
- F. Any sign of subgrade disturbance due to seepage or unaccountable reduction in effluent flow rate shall be immediately reported to the Engineer and steps immediately taken to correct the condition.
- G. All wells and piezometers shall be abandoned at the completion of the work, except as directed by the Engineer, in accordance with NYSDEC guidelines.

3.04 SURFACE WATER

- A. Surface water on and around the site shall be collected into local sumps by means of trenches, pipes, or other means. The Contractor shall discharge the water into the City wastewater collection system. Direct surface water to minimize surface erosion, ponding and softening of slopes and berms, including haul roads and equipment working stations. Slope protection by means of polyethylene sheets, held in place by tires or otherwise, shall be provided locally as required. At the perimeter of the excavation, surface water is to be directed into the storm sewer system and not permitted to enter the excavation. Curbs shall be maintained and, where necessary, extended across intersections, curb cuts and defective curb sections. Surface cracks in the adjacent streets are to be sealed and re-sealed as necessary. Should adjacent settlement occur during the work, curbs shall be raised or water-tight mounds shall be installed as directed by the Engineer to prevent flow into the site. Measures for preventing the pollution of and discharging storm water shall be in accordance with General Specification 02371 -- Dust, Soil Erosion and Sedimentation Control.
  - 1. If surface water flows to a point across a potentially contaminated surface (e.g., contaminated or hazardous soils) or otherwise unsuitable/impermeable surface (e.g., mud mat), removal of said water

via pumping to storm sewers shall require the appropriate dewatering permits from the NYSDEC or NYCDEP Bureau of Water and Sewer Operations (BWSO) Division of Permitting and Connections. The Contractor shall obtain all necessary permits in a timely manner so as not to delay the Work.

3.05 PRETREATMENT OF DEWATERING EFFLUENT

- A. The Contractor shall provide appropriately sized settling tanks to collect and store dewatering effluent commensurate with dewatering discharge rates to allow for settlement of suspended solids and sampling as required by disposal/discharge criteria. The tanks shall be equipped with an overflow collection system to prevent accidental release of dewatering effluent. Routine inspection of the tanks shall be carried out daily to ensure that tank integrity is being maintained, and that all valves or tank openings are properly locked out to avoid accidental discharge. Settling tanks shall be cleaned frequently to prevent excess deposition of solids which could overflow from the tank. Removed solids shall be classified and disposed of in accordance with the requirements of General Specification 02105 - Soil Sampling and Analysis. Transportation and Disposal including waste manifests shall be in accordance with General Specification 02316 - Excavation.
  - 1. The settling tank shall be concrete or steel as manufactured by Rockford, Belvidere, IL or an approved equal, and sized based upon the maximum groundwater flow times a 1.5 safety factor.
- B. The Contractor shall provide appropriately sized oil/water separators to prevent discharge of hydrocarbons, grease and other floatable materials to surface water or the sewer system. Oil/water separators shall be cleaned frequently and collected materials classified and disposed of in accordance with General Specifications 02105 - Soil Sampling and Analysis and 02316 - Excavation requirements for manifests and material transport and disposal.
  - 1. The oil/water separator shall be concrete or steel as manufactured by Rockford, Belvidere, IL or an approved equal, and sized based upon the maximum groundwater flow times a 1.5 safety factor.
- C. The Contractor shall provide treatment for, or remove from the site to an approved disposal facility, all dewatering effluent or groundwater which exceeds any limit set for surface water or sewer discharge, whichever is applicable. Classification and disposal shall conform to General Specifications 02105 - Soil Sampling and Analysis and 02316 - Excavation requirements for manifests and material transport and disposal. .

3.06 DISPOSAL OF DEWATERING EFFLUENT

- A. Dewatering effluent may be affected by rainfall. The Contractor shall provide adequate equalization and holding tanks to allow work to proceed in the case of restricted discharge capability during rain events.
- B. The Contractor shall provide sufficient clean water to flush all sewers and drains when necessary. If any sewer, drain, catch basin, or inlet becomes filled or partially filled with sediment or debris, the Contractor shall promptly and satisfactorily remove such deposits.
- C. The Contractor shall collect dewatering effluent samples as required by the permits and the Dewatering Plan. If pretreatment, other than oil/water separators and settling tanks, is required, the Contractor shall continue to collect effluent samples during dewatering operations, and analyze for all listed parameters at intervals based on dewatering discharge volume as a verification of discharge compliance. Intervals will be as defined in the Dewatering Plan. A copy of all analytical results shall be submitted to the Engineer for review and approval, no later than one day after receipt of such data. The Contractor shall provide for prompt sampling and turn-around times so as not to delay the project, but in no case shall turn-around time be longer than 5 calendar days.
- D. The Contractor shall obtain and pay for all permits, applications and licenses required by law that are associated with the disposal of dewatering effluent, including NYSDEC SPDES Permit, if applicable.
- E. The Contractor shall select and supply Personal Protective Equipment (PPE) in accordance with the Contractor's Site Health and Safety Plan.
- F. Unless otherwise required in the Detailed Specifications, all wells shall be abandoned in place and all other portions of the dewatering system shall be removed by the Contractor after completion of dewatering activities and in accordance with NYSDEC requirements.

END OF SECTION

**GENERAL SPECIFICATION 02240 – DEWATERING**

---

NO TEXT ON THIS PAGE



**GENERAL SPECIFICATION 02316 EXCAVATION**

---

**SECTION 02316**

**Excavation**

PART 1 GENERAL

1.01 SECTION INCLUDES

- A. This Section describes excavation work and reuse or disposal of all material as specified herein, shown on the Contract Drawings or required by the Engineer, for any purpose pertinent to the construction of the Work.
- B. Excavation Work includes stripping and stockpiling of topsoil; sheeting and bracing; excavation over the site; excavation for roads, pipelines and structures; removal and control of water in and around excavations; segregation and stockpiling of excavated material; disposal of unsuitable material and excess excavated material; reuse of suitable material; and trimming, shaping and grading of excavations.
- C. The following index of this Section is included for convenience:

<u>Article</u>	<u>Title</u>	<u>Page</u>
		02316-
PART 1	GENERAL .....	1
1.01	Section Includes .....	1
1.02	Payment.....	2
1.03	Related Sections.....	2
1.04	References.....	2
1.05	Definitions.....	3
1.06	Design Requirements .....	4
1.07	Submittals .....	4
1.08	Regulatory Requirements.....	8
1.09	Certification of Laboratory Services.....	8
1.10	Site Conditions.....	8
1.11	Special Requirements.....	8
PART 2	PRODUCTS.....	8
2.01	General.....	8
PART 3	EXECUTION.....	9
3.01	General.....	9
3.02	Lines and Grades.....	12
3.03	Subgrade Consolidation .....	12
3.04	Frost Prevention .....	13
3.05	Segregation, Storage and Disposal of Materials .....	13
3.06	Sheeting and Bracing .....	13
3.07	Sheeting and Bracing Left in Place.....	16
3.08	Removal of Water .....	17
3.09	Fencing, Bridging and Decking	18

## GENERAL SPECIFICATION 02316 - EXCAVATION

---

### 1.02 PAYMENT

- A. Unless otherwise provided in the Detailed Specifications, no separate payment will be made for performing any Work required under this Section and the Contractor shall include all costs thereof in its lump sum price bid for the Contract.

### 1.03 RELATED SECTIONS

- A. General Specification 02105 - Soil Sampling and Analysis
- B. General Specification 02230 - Site Clearing
- C. General Specification 02240 - Dewatering
- D. General Specification 02317 - Backfilling
- E. General Specification 02318 - Rock Excavation
- F. General Specification 02371 - Dust, Soil Erosion and Sedimentation Control
- G. General Specification 02821 - Metal Fence
- H. General Specification 02920 - Soil Mixes
- I. General Specification 05120 - Structural Steel

### 1.04 REFERENCES

- A. ASTM D1557 - Test Methods for Laboratory Compaction Characteristics of Soil Using Modified Effort (56,000 ft-lbf/ft<sup>3</sup>)
- B. Occupational Safety and Health Administration (OSHA); OSHA 1926 Subpart P-Excavations
- C. U.S. Department of Labor (DOL)
- D. Industrial Board of Appeals, N.Y.S. Department of Labor, Part 23 Protection in Construction, Demolition and Excavation Operations latest editions
- E. New York City Rules and Regulations (RCNY)
- F. New York State Department of Transportation (NYSDOT)
- G. New York City Department of Transportation (NYCDOT)
- H. New York State Department of Environmental Conservation (NYSDEC)
- I. U.S. Department of Transportation, Federal Highway Administration
- J. U.S. Environmental Protection Agency (EPA)
- K. New York City Building Code

## GENERAL SPECIFICATION 02316 EXCAVATION

---

### 1.05 DEFINITIONS

- A. Suitable Material - any material whose composition is satisfactory for use as fill. Any mineral (inorganic) soil, blasted or broken rock and similar materials of natural or man-made (i.e. recycled) origin, including mixtures thereof, are considered suitable materials. Determinations of whether a specific natural material is suitable shall be made by the Engineer on the above basis.
1. Recycled materials that the Engineer has evaluated and approved for general use shall be considered to be suitable material subject to the conditions for use as determined by the City. In general, the use of recycled materials must be sanctioned by NYSDEC, usually in the form of a Beneficial Use Determination (BUD). See definition below.
- B. Unsuitable Materials – any material containing vegetable or organic matter such as muck, peat, organic silt, topsoil or sod, that is not satisfactory for the use as fill material. Certain man-made deposits of industrial waste, or contaminated materials may also be determined to be unsuitable materials.
- C. Pre-Determined Beneficial Use Determination (BUD) – NYSDEC allows soil to be reused on site under a Pre-Determined BUD under the following conditions: 6NYCRR 360.1.15(b)(7) uncontaminated soil which has been excavated as part of a construction project, and which is being used as a fill material, in place of soil native to the site of disposition; 360.1.15(b)(8) non-hazardous, contaminated soil which has been excavated as part of a construction project, other than a NYSDEC-approved or undertaken inactive hazardous waste disposal site remediation program, and which is used as backfill for the same excavation or excavations containing similar contaminants at the same site. Excess materials on these projects are subject to the requirements of Part 360. No *de minimus* quantity of solid waste or historic fill is allowed when reusing soils under both 360.1.15(b)(7) and 360.1.15(b)(8), with the exception of reuse in the same excavation. Refer to General Specification 02105 – Soil Sampling and Analysis, Article 1.06 for sampling requirements for uncontaminated soil and non-hazardous, contaminated soil, and Article 3.01 for a list of parameters to be analyzed for soils to be reused on-site, or soils to be reused or disposed off-site.
- D. Excavated Material: All material regardless of its nature, except rock or boulders that have been excavated. The requirements for excavation of rock and boulders are set forth in General Specification 02318 - Rock Excavation.
- E. Topsoil: Topsoil shall consist of natural loam, free from subsoil, obtained from an area which has never been stripped. Topsoil is friable clay loam surface soil found in a depth of not less than 4 inches, and is substantially free of subsoil, clay lumps, stones, and other objects over 2 inches in diameter, and without weeds, roots, and other objectionable material. Topsoil shall be as further defined under General Specification 02920 - Soil Mixes. Topsoil meeting this

## GENERAL SPECIFICATION 02316 - EXCAVATION

---

definition and General Specification 02920 – Soil Mixes shall be considered suitable for use on-site.

- F. Backfill: Material to be excavated and proposed for reuse as backfill must meet the solid waste cessation requirements of 6NYCRR 360.1.15(b) for a Pre-Determined BUD or 6 NYCRR 360.1.15(d) for a Case-Specific BUD. Backfill shall be non-hazardous and shall meet the requirements of General Specification 02317 – Backfilling.
- G. Case-Specific Beneficial Use Determination (BUD) – Under 6 NYCRR 360.1.15 (d), NYSDEC sets forth the requirements for petitioning NYSDEC to obtain a Case-Specific BUD, and the criteria for reviewing, granting, or denying of the BUD. For reuse of a solid waste to be determined a beneficial use, the petition must demonstrate the following:
  - 1. The use will not adversely affect human health and safety, the environment, or natural resources.
  - 2. The solid waste is an effective substitute for a commercial product or can be used beneficially in the manufacture of a commercial product.
  - 3. The essential nature of the use constitutes a legitimate reuse and not disposal.

### 1.06 DESIGN REQUIREMENTS

- A. In designing the sheeting, take note of the minimum load diagram requirements of the Department, shown in the Attachments A and B at the end of this Section, unless otherwise shown on the Contract Drawings or in the Detailed Specifications. However, when it is anticipated that heavier crane or equipment loads will fall within the influence line of the excavation, increase design loads accordingly.

### 1.07 SUBMITTALS

- A. Sheeting and Bracing: Before commencing any excavating operations, submit for approval Shop Drawings of all sheeting and bracing, cofferdams, bridging, decking, soldier beams and lagging, and other temporary or permanent supporting structures. Shoring and underpinning submittals shall be as required by General Specification 02250 – Shoring and Underpinning.
  - 1. Shop Drawings shall show types of materials, dimensions and details of the entire bracing system, including wale splices and corner connections, stressing/jacking methods, reaction systems, posting and rebracing, if necessary.
  - 2. Provide plans, details and procedures for jacking-in preload at struts.
  - 3. For sheeting and shoring not shown on the Contract drawings submit engineering calculations and design assumptions for determination of loads and stresses acting in the wall and lateral supports during

## GENERAL SPECIFICATION 02316 EXCAVATION

---

installation, as well as final conditions. Show locations at which the temporary or permanent supporting structures will be used. The proposed design shall take into account the excavation procedures, dewatering operations, surcharge loading, soil properties, material stresses, temperatures, permanent construction, stages of work and all other conditions which could affect the excavation support system and the permanent structure. These drawings and calculations shall be prepared and stamped by a Professional Engineer licensed in the State of New York.

- B. Soil Excavation, Reuse, Transport and Disposal Plan (SERTD Plan): Submit a SERTD Plan to the Engineer for approval at least 30 calendar days prior to the start of excavation. The SERTD Plan shall include two protocols: the Excavation Protocol and the Reuse, Transport and Disposal Protocol.
1. The Excavation Protocol shall include, but not be limited to, the following:
    - a. Limits of excavation
    - b. Excavation methods
    - c. Protection methods:
      - 1) Sheet piling and bracing
      - 2) Fencing, bridging and decking
  2. The Reuse, Transport and Disposal Protocol shall address the following waste classifications defined in General Specification 02105 – Soil Sampling and Analysis: hazardous solid waste; non-hazardous contaminated waste (e.g., historic fill, urban, industrial waste, etc.); non-hazardous petroleum-contaminated waste; construction and demolition (C&D) debris; and non-regulated solid waste (e.g., uncontaminated soil reused for fill material, topsoil destined for reuse). The Protocol shall include the following:
    - a. Details on proposed reuse on-site or off-site.
      - 1) Identities of BUD site(s) with copy (ies) of their regulatory approvals, as applicable. Unless otherwise reused under a Pre-Determined BUD, details shall include all supporting back-up information sent to and received from NYSDEC or other applicable out-of-state agency. See General Specification 02105 - Soil Sampling and Analysis for on-site reuse criteria.
      - 2) As applicable, each BUD site or disposal facility's requirements for sampling, including analytical

## GENERAL SPECIFICATION 02316 - EXCAVATION

---

parameters, frequencies, protocols, and minimum detection limits.

- b. Transportation details.
  - 1) Identities of waste transporters, supporting NYSDEC Part 364 Waste Transporter Permit(s) and other out-of-state transporter permits required to transport the wastes to the TSD facilities (TSDFs).

- c. Disposal details.
  - 1) Identities of disposal facilities solicited including names and locations, insurance certificate, permit documentation including the types of materials allowed and not allowed, and chemical and physical material acceptance criteria. If no concentrations are indicated, then the facility must indicate the types of material that it is allowed to accept under its permit. Treatment, storage, or disposal (TSD) of any waste generated by excavation work shall be at a facility permitted to accept such waste by an authorized state or local government agency, or the EPA, as applicable.

- d. Provisions for submittals for DEP signature as generator. The Contractor shall provide waste profiles, facility letters of acceptance of DEP waste, advance copies of waste manifest(s), and Land Disposal Restriction (LDR) Notification and Certification Form (if hazardous waste) for the Engineer's review and approval and DEP signature as generator.

- 3. The SERTD Plan shall be coordinated with the Field Sampling Plan (FSP) and reuse site, waste disposal facility selection and materials acceptance requirements specified in Detailed Specification 02105 – Soil Sampling and Analysis, as applicable.
- 4. The SERTD Plan shall be prepared in accordance with all applicable Federal, State and local hauling and disposal codes and regulations.
- 5. Reuse of excavation spoils either on or off-site must be prioritized over disposal. Disposal facilities shall only be approved where reuse options are not available.

- C. Manifest Requirements and Submittals: Manifests shall include measurements of the volume of all excavated material to be removed from the site prior to transporting to an approved beneficial use site or disposal facility. The Contractor shall also prepare all vehicles and manifests necessary for transporting all material. Non-hazardous waste shall be manifested in a fashion similar to that for hazardous waste. The Contractor shall comply with all

## GENERAL SPECIFICATION 02316 EXCAVATION

---

Federal, State and local regulations regarding the transport of hazardous and non-hazardous waste.

1. **Applicable Regulations:** All Work that concerns the transport of hazardous and non-hazardous waste shall comply with the appropriate EPA and NYSDEC regulations and DOT hazardous material transportation regulations.
2. **EPA Hazardous Waste Manifest:** The Contractor shall obtain an appropriate number of hazardous waste manifest forms (EPA Form 8700-22 (Rev. 3-05) or latest version), sequentially numbered for this Contract based on the quantity of hazardous waste to be removed from site. The name of the generator, transporter and disposal facility, and their appropriate EPA identification number, shall be typed on each form. All other pertinent information shall be included on the manifest. A copy of the partially completed manifest including the above information shall be submitted for approval at least 3 weeks prior to commencement of excavation.
  - a. **Routing:** The Contractor shall provide a map and written description of the route which will be taken to the approved treatment, storage or disposal facility by the hazardous waste transporter.
3. **Non-hazardous Waste Manifest/Bill of Lading:** Manifests/Bills of Lading shall be provided for each truckload of non-hazardous material (i.e., non-hazardous contaminated soil, uncontaminated soil, etc.) removed from the site. The form of the Manifest/Bill of Lading shall be approved by the Engineer. Non-hazardous waste shall be transported in accordance with all applicable Local, State and Federal DOT regulations by properly licensed and permitted waste haulers. Uncontaminated soil shall be removed by a properly licensed hauler.
  - a. **Routing:** The Contractor shall provide a map and written description of the route which will be taken to the approved treatment, storage or disposal facility by the non-hazardous waste transporter.
4. The Contractor shall submit written evidence that selected TSDFs have accepted or will accept the wastes generated during excavation. The Contractor shall also submit copies of the completed manifest, signed and dated by the initial transporter, in accordance with Federal and State requirements and with associated documentation (e.g., Waste Profile and Hazardous Waste LDR Notification and Certification Form). Copies of completed and signed waste manifests from TSDFs shall be provided to the Engineer within seven (7) days of waste shipment off-site.

## GENERAL SPECIFICATION 02316 - EXCAVATION

---

### 1.08 REGULATORY REQUIREMENTS

- A. General: Before proceeding with any excavation, obtain all necessary permits required by City Departments having jurisdiction and consents from owners of private property where their interests may be affected by the Work, such as for temporary or permanent occupation, for disposal or storage of materials, or other encroachment except where temporary easements may have been obtained by the City in connection with permanent easements or otherwise.
- B. Excavation operations and related work shall be performed in strict compliance with the applicable sections of OSHA 1926 Subpart P-Excavations, New York City Department of Buildings Regulations and N.Y.S. Department of Labor, Industrial Board of Appeals, Part 23 Protection in Construction, Demolition and Excavation Operations latest editions.
- C. In the period of 2 to 10 days prior to starting excavation, notify all utilities of intended work locations and have utility locations marked. In NYC, location, the New York City Long Island One Call Center (800-272-4480) is available for this use. Upstate locations are served by Dig Safely NY (800 962-7962 or 811).

### 1.09 CERTIFICATION OF LABORATORY SERVICES

- A. For certification of Laboratory Services see General Specification 02105-Soil Sampling and Analysis.

### 1.10 SITE CONDITIONS

- A. Actual Conditions: Perform any geotechnical investigations deemed necessary to determine actual site conditions. Geotechnical data reports, if they are available, will be described in the Detailed Specifications.
- B. Underground Utilities: Locate and identify all existing underground utilities prior to the commencement of work.

### 1.11 SPECIAL REQUIREMENTS

- A. Dust, Soil Erosion and Sedimentation Control: The Contractor's operations shall conform to the requirements of General Specification 02371 - Dust, Soil Erosion and Sedimentation Control.

## PART 2 PRODUCTS

### 2.01 GENERAL

- A. Steel for struts, braces, and walers shall meet the requirements of General Specification 05120 – Structural Steel and the Contract Drawings.



## GENERAL SPECIFICATION 02316 EXCAVATION

---

### PART 3 EXECUTION

#### 3.01 GENERAL

- A. No excavation Work below the water table shall begin before the Dewatering Plan is approved, as specified in General Specification 02240 - Dewatering.
- B. Clearing and Grubbing: Clear and grub the site of all open cut excavations and all areas shown on the Contract Drawings and specified. The Contractor shall comply with the requirements of General Specification 02230 - Site Clearing.
- C. Stripping: Completely strip all topsoil and earth containing roots away from areas which have been cleared and grubbed. Topsoil which is determined by the Engineer to be suitable for future reuse by the City shall be stripped separately and stockpiled at locations on the site as directed by the Engineer. Topsoil to be reused on-site shall comply with the requirements of General Specification 02920 – Soil Mixes. Topsoil to be reused on-site or off-site may require testing to meet the requirements for a NYSDEC Pre-Determined or Case-Specific BUD, or applicable out-of-state agency requirements for a Case-Specific BUD. For further discussion on topsoil reuse refer to General Specification 02105 – Soil Sampling and Analysis and General Specification 02317 – Backfilling.
- D. Sheeting and Bracing: The Contractor shall provide all labor, equipment, materials and incidental items and services necessary to perform sheeting and bracing as indicated on the Contract Drawings and specified herein and in the Detailed Specifications. Sheeting and bracing shall include but not limited to:
  1. Furnish, install, preload and maintain a system of wales, struts, kickers and bracing appurtenances to shore portions of the earth support walls as shown on the Contract Drawings.
  2. After support is provided, including installation of base slabs, unload and remove wales, struts, kickers and bracing as required.
  3. The arrangement, construction, testing and maintenance of the lateral bracing system shall be the responsibility of the Contractor.
- E. Structure Excavation:
  1. Excavations shall be of sufficient size to permit the Work to be safely and properly constructed in the manner and of the size specified, except where limits of excavation are provided on the Contract Drawings. The bottom of the excavation in earth and rock shall have the shape and dimensions of the underside of the structure with allowance for the concrete work mat or compacted aggregate base layer.
  2. Exercise care to prevent disturbing or loosening of the soil in the excavation. Densify the bearing surface for all structures with an approved type vibratory compactor to 95 percent of the maximum dry density obtainable by ASTM D1557 before the construction of any

## GENERAL SPECIFICATION 02316 - EXCAVATION

---

foundations. Where the depth of disturbed or loosened soils is greater than 12 inches or; as determined by the Engineer, that it will require special compaction; the Contractor shall propose the appropriate method of compaction and submit to the Engineer for approval. All disturbed or loosened soils as determined by the Engineer that should be removed shall be replaced in accordance with the requirements of Paragraph 3.01J "Unauthorized Excavation".

3. Whenever abandoned existing piles are encountered during excavation, they shall be cut off at least 18 inches below the bottom of new footings, unless otherwise indicated on the Contract Drawings, and shall not be pulled.
- F. Site Excavation: Excavate over the site within the limits of site grading to conform to finished site grades. Arrange the excavation work to permit continuous surface drainage off the site, eliminate low spots and surface ponding, and prevent runoff from flowing into the surrounding areas.
- G. Protection of Plants and Structures: Before starting excavation, clear away all obstructions which are to be removed or relocated. Properly brace and protect trees, shrubs, poles and other structures which are to be preserved. Comply with the requirements of General Specification 02230 - Site Clearing.
- H. Trench Excavation:
1. Maintain the minimum trench width adequate to place, joint and backfill the pipe or conduit properly. The clear width of the trench at the level of the top of the pipe shall not exceed the sum of the outside diameter of the pipe barrel plus 20 inches for pipe 4 through 24 inches in diameter nor the outside diameter of the pipe barrel plus 2 feet for pipe more than 24 inches in diameter, unless otherwise approved by the Engineer. The banks of pipe trenches shall be as near to vertical as practicable.
  2. Length of Excavation: Make excavation for the sewers, drains, ducts, conduits or pipe lines only a reasonable distance in advance of pipe laying, at the discretion of the Engineer, and as may be indicated by the supply of materials on hand.
  3. In sheeted trenches, measure the clear width of the trench at the level of the top of the pipe to the inside of the sheeting.
    - a. Pipes placed in trenches wider than specified above shall be provided with concrete cradle or encasement as directed by the Engineer. No separate payment will be made for such cradles or encasement.
    - b. Do not overexcavate the bottom of the trenches. The bottom of trenches shall be graded accurately to provide uniform bearing and support for each section of the pipe on undisturbed soil at

## GENERAL SPECIFICATION 02316 EXCAVATION

---

every point along its entire length (except for the portions of the pipe sections where it is necessary to excavate for bell hole, for the proper sealing of pipe joints, and as hereinafter specified).

- c. Dig bell holes and depressions for joints after the trench bottom has been graded. In order that the pipe rests on the prepared bottom for as nearly its full length as practicable, make bell holes and depressions only of such length, depth, and width as required for properly making the particular type of joint. Remove stones as necessary to avoid point bearing. Except as hereinafter specified for wet or otherwise unstable material, backfill overdepths with materials specified for backfilling the lower portion of trenches. Whenever wet or otherwise unstable material that is incapable of properly supporting the pipe is encountered in the bottom of the trench, over excavate such material (a minimum of 2 feet below pipe) to a depth to allow for construction of stable pipe bedding. Backfill the trench to the proper grade with suitable approved materials as per General Specification 02317 – Backfilling.
  - d. If unstable material is exposed at the level of the bottom of the trench excavation, it shall be excavated in accordance with Paragraph 3.01I “Authorized Additional Excavation”. When the Engineer judges that the unstable material extends to an excessive depth, he may advise the Contractor, in writing, to stabilize the trench bottom with additional select fill or pipe bedding material or to ensure firm support for the pipe or electrical duct by other suitable methods. Payment for such trench stabilization will be made as described for “Authorized Additional Excavation.”
  - e. The open, excavated trench preceding the pipe laying operation and the unfilled trench with pipe in place shall be kept to a minimum length, causing the least possible disturbance. Means of egress shall be located so as to require no more than 25 feet of lateral travel by employees. Ladders shall extend a minimum of 36 inches above the top of the sheeting or be tied down with a grabrail provided.
  - f. No water shall be allowed to rise in the trench excavation until sufficient backfill has been placed to prevent pipe flotation.
- I. Authorized Additional Excavation: In case the materials encountered at the elevations shown on the Contract Drawings are not suitable, or in case it is found desirable or necessary to go to an additional depth or to an additional depth and width, carry the excavation to such additional depth and width as the Engineer may direct in writing. Refill such excavated space with either 2,500

## GENERAL SPECIFICATION 02316 - EXCAVATION

---

psi concrete or compacted select fill materials, as ordered. Where necessary, compact fill materials to avoid future settlement. Use select fill materials meeting the requirements of General Specification 02317 - Backfilling and compact to attain a minimum degree of compaction of 95 percent of the maximum dry density as determined by ASTM D1557. Place backfill in lifts not exceeding 9 inches in loose thickness.

- J. Unauthorized Excavation: Wherever the excavation is carried beyond or below the lines and grades shown on the Contract Drawings or given by the Engineer, except as specified in Paragraph 3.01I "Authorized Additional Excavation", refill all such excavated space with such material and in such a manner as may be directed by the Engineer to insure the stability of the various structures. Areas excavated beneath all manholes, structures, pipelines or conduits without authority shall be refilled by the Contractor at his own expense with 2,500 psi concrete or compacted select fill material and properly compacted as ordered by the Engineer.
- K. Explosives: Do not use explosives for any clearing, grubbing or excavation work as per General Specification 02230 – Site Clearing.

### 3.02 LINES AND GRADES

- A. General: Excavate for sewers, drains, conduits, pipe lines, walls, foundations, footings, and other structures, including any excavating indicated on the Contract Drawings or necessary, to the lines and grades shown on the Contract Drawings, specified or required.
- B. Demolition: Cut pavements, curbs and sidewalks with non-impact tools or other equipment approved by the Engineer. Breaking of pavements, curbs and sidewalks by impact, such as with the use of a ball, is not permitted. When removing sections next to sections that are to remain, sawcut the full depth of the concrete and asphalt.
- C. Adequate Space: Do all trimming, grading and other incidental work to the grades and slopes shown on the Contract Drawings, specified or required as approved by the Engineer. Perform all excavations of sufficient size for the proper execution and inspection of the work. Keep excavation in good condition at all times and fill all voids which may endanger existing structures to the satisfaction of the Engineer.

### 3.03 SUBGRADE CONSOLIDATION

- A. Consolidating Suitable Materials: Materials used in the bottom of excavation to replace boggy and other yielding or unsuitable materials, for providing solid and firm foundations for the structures to be built thereon, where approved in writing, may be either select fill or lean concrete.

## GENERAL SPECIFICATION 02316 EXCAVATION

---

### 3.04 FROST PREVENTION

- A. Protection shall be provided against the penetration of frost into material below the bearing level during work in the winter months. This protection shall consist of a temporary blanket of straw or salt hay covered with a plastic membrane or other approved means.

### 3.05 SEGREGATION, STORAGE AND DISPOSAL OF MATERIALS

- A. Segregating: All unsuitable material which may be excavated by the Contractor shall be kept separated from suitable excavated material which may be reused on-site or off-site under a NYSDEC Pre-Determined or Case-Specific BUD or other applicable out-of-state agency's Case-Specific BUD, or disposed off-site. Unsuitable material shall be sampled and analyzed in accordance with the requirements of General Specification 02105-Soil Sampling and Analysis. Removal and disposal of hazardous waste and non-hazardous waste shall be as described in the approved Soil Excavation, Transport and Disposal Plan.
- B. Stockpiling:
  - 1. Excavated material to be used for backfilling on-site under the NYSDEC Pre-Determined or Case-Specific BUD shall be so piled and placed as not to encumber sidewalks or roadways, or wash away or obstruct the free flow of surface or drainage water. Excavated material shall not be placed closer to the edge of an excavation than a distance equal to 1-1/2 times the depth of the excavation, unless the excavation is in rock or the sides of the excavation have been sloped or sheeted and shored to withstand the lateral forces imposed by such superimposed loads.
  - 2. Stockpile cover and liner material and installation requirements should be as specified in General Specification 02371 – Dust, Soil Erosion and Sedimentation Control.

- C. Excess Materials: The Contractor shall make arrangements for transportation and reuse of the soil on-site or off-site under a NYSDEC Pre-Determined or Case-Specific BUD, or applicable out-of-state agency's Case-Specific BUD. If reuse is not an option, only then may the Contractor dispose of excess materials.

### 3.06 SHEETING AND BRACING

- A. General: All excavations shall be excavated with vertical sides and properly sheeted and braced for the full depth of the excavations, unless otherwise shown on the Contract Drawings, specified or ordered in writing by the Engineer. All excavation shall be shored and braced in accordance with 29 CFR 1926 Subsection P requirements and New York City Department of Buildings regulations.
- B. Pilot cuts for excavations shall not exceed five feet in depth and shall be made with equipment approved by the Engineer. The equipment to be used and the

## GENERAL SPECIFICATION 02316 - EXCAVATION

---

- method to be employed in starting the sheeting operation shall be submitted for approval and must be approved in writing by the Engineer before the start of work.
- C. Exception: Excavation for structures or pipe lines five feet in depth or less need not be sheeted and braced except where excavation is in close proximity to existing footings or conduits and where unsupported sides may be unstable.
- D. Design and install sheeting and bracing in excavations for pipe lines so that at no time shall sheeting be braced or blocked against the sides of pipe or conduit. Do not drive sheeting for pipelines below the elevation of the bottom of the pipe. If it is necessary to drive the sheeting below that elevation in order to obtain a dry trench or satisfactory working conditions, cut off the sheeting and leave in place below the top of the pipe at no additional cost to the City.
1. Contractor shall design and provide additional and supplemental sheeting and bracing as needed to perform the excavation.
  2. Adjust field locations of wales, rakers, struts and braces as required and approved by the Engineer to avoid interference with new work and provide sufficient bearing. Block between wales and sheets with steel shims immediately after installing braces.
  3. Struts shall be wedged, posted and tied to form a stiff support. Rakers and struts to be preloaded shall be jacked to the loads shown on the Contract Drawings. Rakers and struts shall be preloaded in the presence of the Engineer.
  4. Provide web stiffeners, plates or angles as needed to prevent rotation, crimping or buckling of connections and points of bearing between structural steel members and/or jacks occasioned by eccentricities caused by field fabrication, assembly or conditions.
  5. Protect bracing members from damage by construction equipment and other causes. Repair any damage promptly and erect temporary barriers to secure area of damage, as required.
- E. Where permitted or ordered in writing by the Engineer, slope the sides of the excavation to elevations approved by the Engineer and excavate below such elevations with vertical sides, properly sheeted and braced. Side slopes must be stable. Banks more than 5 feet high shall be shored and sloped to the angle of repose in accordance with current OSHA standards to furnish safe working conditions, to prevent shifting of material, to prevent damage to structures or other work and to avoid delay to the work, all in compliance with U.S. Department of Labor Safety and Health Regulations for construction promulgated under the Occupational Safety and Health Act of 1970 and under Contract Work Hours and Safety Standards Act, as amended. The minimum shoring, sheeting and bracing for trench excavations shall meet the general

## GENERAL SPECIFICATION 02316 EXCAVATION

---

trenching requirements of the applicable safety and health regulations. However, in no case shall the sides of trench excavations for pipe or conduit be sloped to elevations lower than two feet above the top of the pipe or conduit.

F. Removal of sheeting:

1. When the sheeting and bracing for the vertical sides of such trench excavations is not required to be left in place, such sheeting and bracing shall be removed, and backfill shall be placed and compacted to an elevation at least 1'-6" above the top of the pipe or conduit. Any exception to this requirement will be specified in the Detailed Specifications or shown on the Contract Drawings.
2. Where sheeting and bracing is removed, it shall be done as the excavation is refilled in a manner to avoid the caving in of the bank or disturbance to adjacent areas or structures, except as otherwise shown on the Contract Drawings or directed. Carefully fill voids left by the withdrawal of the sheeting by ramming or otherwise as directed by the Engineer.
3. Obtain permission of the Engineer before the removal of any shoring, sheeting or bracing. Such permission by the Engineer shall not relieve the Contractor of responsibility for injury to structures or to other property or persons resulting from failure to leave such sheeting and bracing in place.
4. Load from rakers, struts and corner braces shall be released in a controlled fashion by cutting kickers and removing wedges and shims, as approved by the Engineer.

G. Credit: Sheetting and bracing required to be provided by the Contract Drawings or the Sections and subsequently allowed or ordered in writing by the Engineer to be omitted shall be subject to suitable credit to the City. Measurement of sheeting and bracing limits subject to suitable credit shall extend from the subgrade to within 18 inches of the ground surface in the case of vertical sides, regardless of stages; and shall extend from the subgrade to 12 inches above the junction of the vertical and sloping sides in the case of excavations with sloped sides above and vertical sides below. Sheetting and bracing indicated to be omitted on the Contract Drawings or in the Detailed Specifications will not be subject to credit.

H. Width: The width of trenches, between inner faces of sheeting or rock, as the case may be, shall not exceed the width of the structure to be installed by more than three feet. Where two or more stages of sheeting are used, the width of trench shall not exceed the width of structure by three feet at the lowest stage of sheeting to a point two feet above the top of pipe or conduit.

## GENERAL SPECIFICATION 02316 - EXCAVATION

---

- I. In cases where sheeting and bracing will not adequately protect adjacent structures from damage and settlement, the Contractor shall employ other methods, such as underpinning. He shall hold the City harmless from all claims for damage arising from failure to adequately protect all structures. He will be presumed to have fully examined and inspected the buildings before estimating the costs and hazards involved.
- J. If, in the opinion of the Engineer, any of the approved temporary or permanent supporting structures are inadequate or unsuitable for the actual conditions in the field, the Engineer may direct the Contractor to strengthen the supporting structures at no additional cost to the City. The Contractor shall be responsible for the sufficiency of all temporary and permanent supporting structures whether or not directed by the Engineer to strengthen them.

### 3.07 SHEETING AND BRACING LEFT IN PLACE

- A. All sheeting and bracing in excavations for sewer pipelines, including manholes and chambers, shall be left in place except where otherwise shown on the Contract Drawings, specified or ordered in writing by the Engineer. Sheeting left in place shall be cut off at the elevation shown on the Contract Drawings, or at least 18 inches below final grade. Bracing remaining in place shall be driven up tight.
- B. Where it is necessary to remove cross braces to make way for sewer pipe, manholes, and chambers, rebrace the sheeting in a manner approved by the Engineer, but in no case shall sheeting be braced against the sides of pipe or structures, unless approved in writing by the Engineer.
- C. Leave sheeting and bracing in place in excavations for structures other than pipe lines where shown on the Contract Drawings, specified or ordered in writing by the Engineer to be left in place. Where such sheeting is to be left in place, the original braces shall not be removed and the sheeting shall be rebraced against the structure unless it is approved by the Engineer.
- D. Sheeting and bracing to be left in place shall include all elements of the sheeting and bracing regardless of the type used, except such braces required to be removed to make way for the structure or pipeline being constructed. Where lagging and "soldier" beams are used, the "soldier" beams shall also be left in place.
- E. In excavations with vertical sides for the full depth, cut off sheeting left in place at the elevations provided in writing by the Engineer, but in general, such cutoffs shall not be less than 18 inches below the existing ground surface. In excavations with sloped sides above and vertical sides below, cut off sheeting at the top of the vertical sides of the excavation. Cut off timber sheeting by sawing, and steel sheeting or "soldier" beams by burning. Breaking off sheeting will not be permitted.



## GENERAL SPECIFICATION 02316 EXCAVATION

---

- F. Do not remove sheeting and bracing not shown on the Contract Drawings or specified to be left in place without first obtaining a statement in writing from the Engineer that such sheeting may be removed.
  - G. No separate payment will be made for sheeting and bracing left in place, the cost thereof shall be included in the price or prices bid for the work under this Contract, except when separate payment for sheeting and bracing ordered in writing by the Engineer to be left in place is provided for in the Detailed Specifications.
- 3.08 REMOVAL OF WATER
- A. Conform to the requirements of General Specifications 02240 - Dewatering and 02371 - Dust, Soil Erosion and Sedimentation Control.
  - B. Care of Water: At all times during the Work, including final inspection, provide and maintain ample means and suitable equipment with which to promptly remove and properly dispose of all water entering excavations or other parts of the Work. Keep all excavations dry at all times until the structures to be built therein are completed and backfilled to approximately final grades except where otherwise approved by the Engineer in writing. Do not permit sewage from existing sewers and house connections to flow into excavations.
  - C. To prevent flotation or uplift of the structure or portions of the structure under construction, provide approved dewatering or freezing methods which shall operate under supervision 24 hours per day, including holidays and weekends. Maintain this dewatering or other system in continuous operation until the structure or portions of the structure are substantially completed to a gravity load 10 percent greater than the upward load caused by the ground water uplift pressure measured and computed from the original ground water level. Place backfill and mechanically compact it to approximately final grade after the structure has achieved the required strength, except where otherwise approved by the Engineer in writing. In addition, provide and have available at the work site suitable standby equipment for prompt replacement during breakdowns of operating equipment.
  - D. The dewatering system shall be maintained in operation as required in Section 02240 – Dewatering.
  - E. Obtain written approval from the Engineer before discontinuing the dewatering or other groundwater control system.
  - F. Where water or sewage has accumulated or is flowing in the completed or partly completed structures, remove and dispose of such water or sewage during the time covered by the Contract, unless otherwise directed by the Engineer.
  - G. The Contractor shall take care of all sewer drainage interfered with by his operations to the satisfaction of the Engineer. Drainage into trench excavations is expressly prohibited.

3.09 FENCING, BRIDGING AND DECKING

- A. All excavations or openings made under this Contract in any public street, park or place, or in any adjoining property, shall be immediately enclosed by a guard fence constructed in a neat and workmanlike manner in accordance with the requirements of General Specification 02821-Metal Fence. Where a tight board fence is specified, no guard fence will be required, provided there is no delay in the erection of the tight board fence.
- B. Wherever a driveway occurs, construct a bridge of adequate strength and width and provide with side railings to span the excavation.
- C. Wherever the distance between available crossings over the excavation is, in the opinion of the Engineer, excessive, he may order a temporary foot bridge with side rails to be constructed.
- D. At all street intersections, excavations made from the surface shall be decked over in a substantial manner so that traffic can be maintained at all times except as herein provided for. The removal of the pavement and the placing of the decking shall be done during the hours of a day or night which will cause the least inconvenience to adjoining property owners and to public traffic in general. During certain designated hours of the day or night, sections of planking not more than ten feet in length may be temporarily removed for the purpose of removing excavated material, receiving materials of construction or for backfilling.

END OF SECTION

ATTACHMENTS A and B, SHOWING THE MINIMUM NORMAL LOAD DIAGRAM REQUIREMENTS OF NYC DEP FOR SHEETING DESIGN DURING EXCAVATION ARE GIVEN IN THE FOLLOWING PAGES (ALSO SEE PARAGRAPH 1.06)

# GENERAL SPECIFICATION 02316 EXCAVATION

## Attachment A

MINIMUM LOAD DIAGRAM FOR NON-WATER  
TIGHT SHEETING DESIGN

(Revised 9/88)

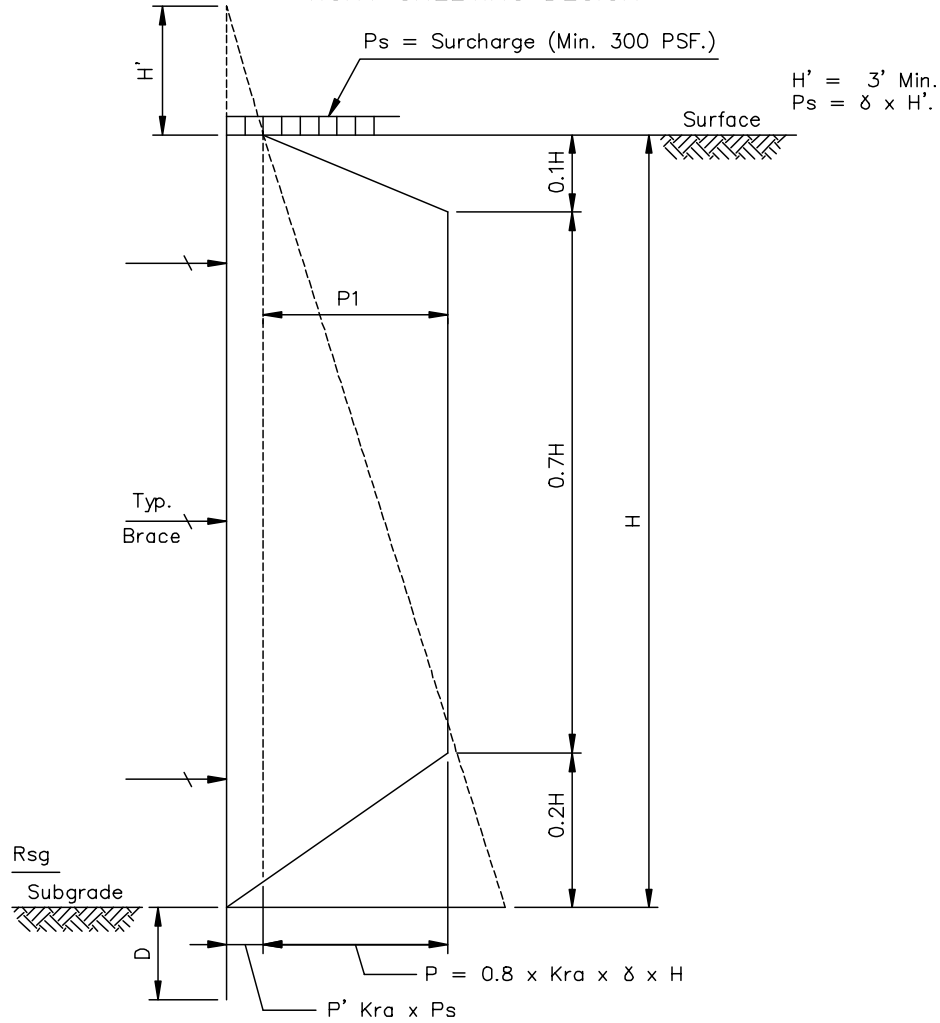

$\delta$  = Unit Weight of Soil

$\delta_w$  = Unit Weight of Water

$\delta_s$  = Unit Weight of Submerged Soil

$\phi$  = Angle of Internal Friction of Soil

$K_{ra} = \frac{(1 - \sin \phi)}{(1 + \sin \phi)}$  For Active Earth Pressure

$K_{rp} = \frac{(1 + \sin \phi)}{(1 - \sin \phi)}$  For Passive Earth Pressure

$D = \sqrt{\frac{2 R_{sg}}{\delta (K_{rp} - K_{ra})}}$  (1.3)  
(Min. 2'-0")

# GENERAL SPECIFICATION 02316 - EXCAVATION

## Attachment B

(Revised 9/88)

### MINIMUM LOAD DIAGRAM FOR WATER TIGHT SHEETING DESIGN

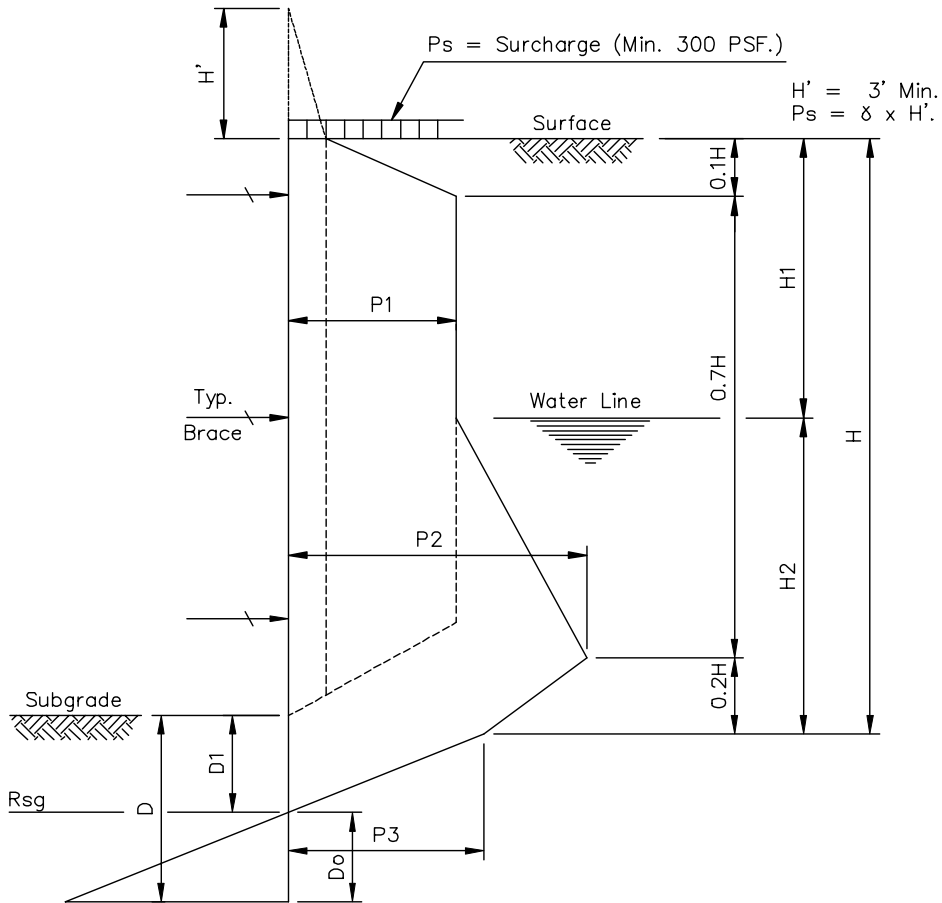

$$P' = K_{ra} \times P_s$$

$$P_1 = P' + 0.8 \times K_{ra} \times (\delta H_1 + \delta_s H_2)$$

$$P_2 = P_1 + \delta_w (H_2 - 0.2H)$$

$$P_3 = \delta_w \times H_2$$

$$D_1 = \frac{P_3}{\delta_s (K_{rp} - K_{ra})}$$

$$D_o = \sqrt{\frac{2 R_{sg}}{\delta_s (K_{rp} - K_{ra})}}$$

$$D = (D_1 + D_o) (1.3)$$

**GENERAL SPECIFICATION 02317 BACKFILLING**

---

**SECTION 02317**

**Backfilling**

**PART 1 GENERAL**

**1.01 SECTION INCLUDES**

- A. Backfilling Work includes furnishing, placing and compacting all fill material necessary to bring excavations and site work to final grade as shown, specified or required.
- B. Backfilling – If the soil meets the requirements for a NYSDEC Pre-Determined or Case-Specific Beneficial Use Determination (BUD), maximize reuse of soil on-site for backfilling rather than import soil from other sources.
- C. The following index of this Section is included for convenience:

<u>Article</u>	<u>Title</u>	<u>Page</u>
		02317-
PART 1	GENERAL .....	1
1.01	Section Includes .....	1
1.02	Payment.....	2
1.03	Related Sections.....	2
1.04	References.....	2
1.05	Definitions.....	3
1.06	Submittals .....	4
1.07	Quality Control .....	5
1.08	Delivery and Storage.....	6
PART 2	PRODUCTS.....	6
2.01	Backfill Material - General .....	6
2.02	Drainage Fill .....	7
2.03	Select Fill .....	7
2.04	Common Fill .....	8
2.05	Pipe Bedding.....	8
2.06	Lightweight Fill .....	9
2.07	Flowable Fill .....	9
PART 3	EXECUTION.....	9
3.01	General.....	9
3.02	Electrical Duct and Structure Bedding .....	10
3.03	Pipe Bedding and Initial Backfill.....	10
3.04	Placement of Flowable Fill .....	11
3.05	Trench Backfill .....	11
3.06	Structure Backfill .....	13
3.07	Drainage Blanket .....	14
3.08	Earth Embankments .....	14

## GENERAL SPECIFICATION 02317 BACKFILLING

---

- |      |                             |    |
|------|-----------------------------|----|
| 3.09 | Compaction Equipment .....  | 14 |
| 3.10 | Finish Grading .....        | 15 |
| 3.11 | Field Quality Control ..... | 15 |
- 1.02 PAYMENT
- A. Unless otherwise provided in the Detailed Specifications, no separate payment will be made for performing any Work required under this Section and the Contractor shall include all costs thereof in its lump sum price bid for the Contract.
- 1.03 RELATED SECTIONS
- A. General Specification 02105 – Soil Sampling and Analysis
- B. General Specification 02371 - Dust, Soil Erosion and Sedimentation Control
- C. General Specification 02910 - Plantings
- D. General Specification 03300 - Cast-in-Place Concrete
- 1.04 REFERENCES
- A. ASTM C131 - Standard Test Method for Resistance to Degradation of Small-Size Coarse Aggregate by Abrasion and Impact in the Los Angeles Machine
- B. ASTM C143 - Standard Test Method for Slump of Hydraulic-Cement Concrete
- C. ASTM C330 - Lightweight Aggregates for Structural Concrete
- D. ASTM D422 - Standard Test Method for Particle-Size Analysis of Soils
- E. ASTM D698 - Standard Test Methods for Laboratory Compaction Characteristics of Soil Using Standard Effort (12,400 ft-lbf/ft<sup>3</sup> (600 kN-m/m<sup>3</sup>))
- F. ASTM D1556 - Standard Test Method for Density and Unit Weight of Soil in Place by the Sand-Cone Method
- G. ASTM D1557 - Standard Test Methods for Laboratory Compaction Characteristics of Soil Using Modified Effort (56,000 ft-lbf/ft (2,700 kN-m/m<sup>3</sup>))
- H. ASTM D2167 - Standard Test Method for Density and Unit Weight of Soil in Place by the Rubber Balloon Method
- I. ASTM D4318 - Standard Test Method for Liquid Limit, Plastic Limit and Plasticity Index of Soils

## GENERAL SPECIFICATION 02317 BACKFILLING

---

- J. ASTM D4832 - Standard Test Method for Preparation and Testing of Controlled Low Strength Material (CLSM) Cylinders
  - K. ASTM D6023 - Standard Test Method for Density (Unit Weight), Yield, Cement Content, and Air Content (Gravimetric) of Controlled Low Strength Material (CLSM)
  - L. ASTM D6024 - Test Method for Ball Drop on Controlled Low Strength Material (CLSM) to Determine Suitability for Load Application
  - M. ASTM D6938 - Standard Test Methods for In-Place Density and Water Content of Soil and Soil-Aggregate by Nuclear Methods (Shallow Depth)
  - N. DER-10, Technical Guidance for Site Investigation and Remediation, NYSDEC Division of Environmental Remediation
  - O. Commissioner Policy CP-51 Soil Cleanup Guidance Policy, Issued 10/21/2010; Effective 12/03/2010, NYSDEC Division of Environmental Remediation
  - P. 6 NYCRR Part 375, Environmental Remediation Programs
  - Q. 6 NYCRR Part 360, Solid Waste Management Facilities NYC Building Code
- 1.05 DEFINITIONS
- A. Suitable Material -- any material whose composition is satisfactory for use as fill. Any mineral (inorganic) soil, blasted or broken rock and similar materials of natural or man-made (i.e. recycled) origin, including mixtures thereof, are considered suitable materials. Determinations of whether a specific natural material is suitable shall be made by the Engineer on the above basis.
    - 1. Recycled materials that the Engineer has evaluated and approved for general use shall be considered to be suitable material subject to the conditions for use as determined by the City. In general, the use of recycled materials must be sanctioned by NYSDEC, usually in the form of a BUD. See definition below.
  - B. Unsuitable Materials – any material containing vegetable or organic matter such as muck, peat, organic silt, topsoil or sod, that is not satisfactory for use as fill material. Certain man-made deposits of industrial waste, or contaminated materials may also be determined to be unsuitable materials.
  - C. Pre-Determined Beneficial Use Determination (BUD) – NYSDEC allows soil to be reused on site under a Pre-Determined BUD under the following conditions: 360.1.15(b)(7) uncontaminated soil which has been excavated as part of a construction project, and which is being used as a fill material, in place of soil native to the site of disposition; 360.1.15(b)(8) non-hazardous, contaminated soil which has been excavated as part of a construction project, other than a NYSDEC-approved or undertaken inactive hazardous waste

## GENERAL SPECIFICATION 02317 BACKFILLING

---

disposal site remediation program, and which is used as backfill for the same excavation or excavations containing similar contaminants at the same site.

- D. Case-Specific Beneficial Use Determination (BUD): Under 6 NYCRR 360.1.15 (d), NYSDEC sets forth the requirements for petitioning NYSDEC to obtain a Case-Specific BUD, and the criteria for reviewing, granting, or denying of the BUD. For reuse of a solid waste to be determined a beneficial use, the petition must demonstrate the following:
1. The use will not adversely affect human health and safety, the environment, or natural resources.
  2. The solid waste is an effective substitute for a commercial product or can be used beneficially in the manufacture of a commercial product.
  3. The essential nature of the use constitutes a legitimate reuse and not disposal.

### 1.06 SUBMITTALS

- A. The Contractor shall submit shop drawings for the approval of the Engineer. Submittals shall include, but not be limited to:
1. Name and location of all suppliers.
  2. Certificate of compliance with standard specified for each source of material.
  3. The Contractor shall submit all laboratory analytical reports, which shall include a Summary Table listing the analytical results with highlighted exceedances of 6 NYCRR Part 375 SCOs.
  4. Prior to stockpiling or placing of select fill materials at the job site, submit for approval approximately 100-pound samples representative of the fill at the proposed borrow source. In addition, submit documentation of the availability of the required fill quantities at any proposed borrow source.
  5. Submit optimum moisture – maximum density curves and reports for all fill materials before placement of fill.
  6. Results of all compaction tests for fill placement.
  7. Mix design for flowable fill, including all materials used and trial mix test results.
  8. Certification by the lightweight fill producer of the gradation, dry loose unit weight, dry compacted unit weight and Los Angeles Abrasion Test lost for the proposed lightweight fill source.



## GENERAL SPECIFICATION 02317 BACKFILLING

---

### 1.07 QUALITY CONTROL

- A. Testing: The Contractor shall retain the services of an independent materials testing laboratory to perform the following laboratory and field tests.
- B. All materials used in construction, whether brought to the site or developed from on-site sources, shall be tested for optimum moisture-maximum density curve, and reports of the test results for each source shall be submitted promptly. The tests shall be as follows:

Test	ASTM Standard	Tests Per Volume Delivered
Gradation	D422	1 per 200 C.Y.
Compaction or Density	D1557	1 per 200 C.Y.

- C. Acceptability of completed compaction shall be demonstrated by tests performed by the Contractor and accepted by the Engineer. The minimum number of tests shall be determined by quantity of material placed, and reports of the test results shall be submitted promptly. The Contractor shall perform either of the following tests subject to the approval of the Engineer:

Test	ASTM Standard	Tests Per Volume Placed
In-Place Density	D2167 D6938	1 per 200 cy

- D. The Contractor shall engage the services of a testing laboratory, with the qualifications required by General Specification 03300 - Cast-in-Place Concrete, and experienced in design and testing of flowable fill materials and mixes, to perform material evaluation tests and to design mixes for flowable fill. A trial mix shall be performed to verify the flowable fill mix design. The trial mix shall also report slump, air content, yield, cement content, and dry unit weight per ASTM C143 and ASTM D6023.
- E. Any fill material being brought to the site that is composed of soil or a mixture of soil (excluding gravel, crushed stone, limestone screenings, other granular materials or flowable fill), as well as any soil being used for drainage fill, common fill and pipe bedding for small piping, must comply with the following protocol:
  - 1. Testing shall be performed on all soil brought on-site (fill and topsoil) and shall demonstrate chemical quality meeting the lower of 6 NYCRR Part 375-6.8(b) Protection of Public Health – Residential and Protection

## GENERAL SPECIFICATION 02317 BACKFILLING

---

of Groundwater SCOs in accordance with General Specification 02105 – Soil Sampling and Analysis, unless otherwise approved by the Engineer. Fill material to be used in ecologically sensitive sites (e.g., wetlands) shall meet the SCOs for the Protection of Ecological Resources, unless otherwise approved.

2. Chemical analyses shall include the 6 NYCRR Part 375-6 compounds and shall be performed by a testing laboratory certified by the New York State Department of Health Environmental Laboratory Accreditation Program (NYSDOH-ELAP). The frequency of testing per volume of fill shall be:
  - a. 1 per 500 CY of material purchased from a registered/permitted processing or recycling facility; or
  - b. 1 per 1000 CY of native materials (e.g., non-regulated soil and sand with no manmade materials) purchased from an operating gravel pit or similar facility.

- F. When testing is required to confirm the reuse of on-site excavation spoils under a Pre-Determined BUD, or under a Case-Specific BUD, sample the soils in accordance with General Specification 02105 – Soil Sampling and Analysis.

### 1.08 DELIVERY AND STORAGE

- A. Materials delivered to the site shall be stored in a manner to prevent contamination and segregation. .

## PART 2 PRODUCTS

### 2.01 BACKFILL MATERIAL - GENERAL

- A. Backfill shall be composed of suitable materials.
  1. On-site Materials: Soil that is excavated and reused as backfill on-site must meet the solid waste cessation requirements of 6 NYCRR 360.1.15(b) for a Pre-Determined BUD or 6 NYCRR 360.1.15(d) for a Case-Specific BUD. Backfill may require sampling and analyses as per General Specification 02105 – Soil Sampling and Analysis. Reuse of soils under a NYSDEC Pre-Determined BUD or Case-Specific BUD is preferred over the importation of soil from off-site sources.
  2. Off-site Imported Materials: Fill that is brought on site to be used as backfill must meet the lower of 6 NYCRR Part 375-6.8(b) Protection of Public Health – Residential and Protection of Groundwater SCOs, unless otherwise approved by the Engineer. Fill material to be used in ecologically sensitive sites (e.g., wetlands) shall meet the SCOs for the protection of Ecological Resources, unless otherwise approved.

## GENERAL SPECIFICATION 02317 BACKFILLING

---

- B. Follow common fill requirements whenever drainage or select fill is not specified. Determine and obtain the approval of the Engineer for the appropriate test method where more than one compaction test method is specified.
- C. Do not use wet or frozen material for backfilling.
- D. The maximum stone size shall be two-thirds of the thickness of the backfill lift, but in no case shall material containing stones over 10 inches in the largest dimension be used for backfill.

### 2.02 DRAINAGE FILL

- A. Use clean gravel, crushed stone, or other suitable material conforming to the gradation specified for drainage fill. Clay and fine particles are unacceptable in drainage fill. Provide drainage fill that complies with the following gradation limits:

U.S. Standard Sieve	Percent Passing By Weight
1-1/2 inch	100
1 inch	95-100
1/2 inch	45-65
#4	5-15
#16	0-4

### 2.03 SELECT FILL

- A. Use gravel, crushed stone, limestone screenings or other granular or similar materials, as approved, which can be readily and thoroughly compacted to not less than 95 percent of the maximum dry density obtainable by ASTM D1557. Very fine sand, uniformly graded sands and gravels, or other materials that have tendency to flow under pressure when wet are unacceptable as select fill. Provide select fill that complies with the following gradation limits:

U.S. Standard Sieve	Percent Passing By Weight
2 inch	100
1-1/2 inch	90-100
1 inch	75-95
1/2 inch	45-70

## GENERAL SPECIFICATION 02317 BACKFILLING

---

U.S. Standard Sieve	Percent Passing By Weight
#4	25-50
#10	15-40
#200	5-15

### 2.04 COMMON FILL

- A. Material from on-site excavation may be used as common fill provided that it can be readily compacted to not less than 90 percent of the maximum dry density obtainable by ASTM D1557, and does not contain unsuitable material as per Articles 1.05B. Additionally, existing on-site soil must comply with the sampling requirements for a NYSDEC Pre-Determined BUD or a Case-Specific BUD as per General Specification 02105 - Soil Sampling and Analysis. Select fill may be used as common fill at no change in the Contract Price.
- B. Granular on-site material that complies with the following gradation limits may be used as granular common fill:

U.S. Standard Sieve	Percent Passing By Weight
3 inch	100
#10	50-100
#60	20-90
#200	0-20

- C. Cohesive site material may be used as common fill as follows:
1. The gradation requirements do not apply to cohesive common fill.
  2. Use material having a liquid limit less than or equal to 40 and a plasticity index less than or equal to 20, as determined by ASTM D4318.
- D. All material used as common fill is subject to approval by the Engineer. If there is insufficient suitable material on site, import whatever additional material is required which conforms to the sections, at no additional cost to the City.

### 2.05 PIPE BEDDING

- A. Gradation for Small Piping: For pipe 18 inches or less in diameter, use pipe bedding material of which 90 percent will be retained on a No. 8 sieve and 100 percent of which will pass a 1/2 inch sieve and be well graded between those limits.

## GENERAL SPECIFICATION 02317 BACKFILLING

---

- B. Gradation for Large Piping: For pipe larger than 18 inches in diameter, use the same pipe bedding material as specified for smaller pipe or use a similar well graded material of which 90 percent will be retained on a No. 8 sieve, 100 percent will pass a 1-inch sieve, and will be well graded between those limits.

### 2.06 LIGHTWEIGHT FILL

- A. Lightweight fill shall be a lightweight aggregate produced by the rotary kiln method and meeting the requirements of ASTM C330. No byproduct slags or cinders are permitted.
- B. The material shall meet the grading requirements of ASTM C330, Table 1, Coarse Aggregate: 3/4 inch to No. 4.
- C. Dry loose unit weight shall be maximum of 55 pcf. Dry compacted unit weight shall be a maximum of 60 pcf when measured by a one-point test performed in accordance with ASTM D698.
- D. Maximum Los Angeles Abrasion Test loss of 50 percent when tested in accordance with ASTM C131 (B grading).

### 2.07 FLOWABLE FILL

- A. Flowable fill (also known as controlled low strength material) shall be a uniform mixture of sand, Type II Portland cement, fly ash, slag, admixtures, and water. The mix design shall produce a flowable material with little or no bleed water which produces a minimum compressive strength of 50 psi and maximum compressive strength of 100 psi at 56 days. The cured material shall be excavatable and have a maximum dry unit weight of 100 pounds per cubic foot. Slump shall be from 7 inches to 10 inches.
- B. Admixtures specifically designed for flowable fill shall be used to improve flowability, reduce unit weight, control strength development, reduce settlement and reduce bleed water. Admixtures shall be:
  1. Rheocell-Rheofill manufactured by BASF;
  2. DaraFill manufactured by W.R. Grace Construction Products;
  3. Or an approved equal.

All other materials shall be as specified in General Specification 03300 - Cast-in-Place Concrete.

## PART 3 EXECUTION

### 3.01 GENERAL

- A. Backfill all excavations to the original surface of the ground or to such other grades as may be shown or required. For areas to be covered by lawn mix, leave or stop backfill 12 inches below the finished grade or as otherwise required to

## GENERAL SPECIFICATION 02317 BACKFILLING

---

- provide adequate depth of lawn mix to satisfy the requirements of General Specification 02910 – Plantings.
- B. Remove from all backfill, and from the space being backfilled, any compressible, putrescible, or destructible rubbish and refuse before backfilling is started. Dispose of the rubbish and refuse in accordance with the requirements of Detailed Specifications.
  - C. Leave sheeting and bracing in place or remove as the Work progresses, as shown in the Contract drawings, specified or directed by the Engineer.
  - D. Do not permit backfilling construction equipment to travel against or over cast-in-place concrete structures until the specified concrete strength has been obtained, as verified by concrete test cylinders. In special cases where conditions warrant, the above restriction may be modified provided the concrete has gained sufficient strength, as determined from test cylinders, to satisfy design requirements for the removal of forms and the application of load.
  - E. All stockpiled materials shall be adequately handled as required in General Specification 02371 – Dust, Soil Erosion and Sedimentation Control.
  - F. No material shall be placed until satisfactory test reports for material type and compaction requirements have been approved by the Engineer.
  - G. Warning tape/ribbon shall be placed and/or restored as required when backfilling new and existing utility lines.

### 3.02 ELECTRICAL DUCT AND STRUCTURE BEDDING

- A. All electrical ducts and precast manhole bases shall be bedded in well graded, compacted, select fill material. Select fill shall be placed in uniform layers not greater than 9 inches in loose thickness and compacted in place with suitable mechanical or pneumatic tools to not less than 95 percent of the maximum dry density as determined by ASTM D1557. Bedding thickness shall be not less than 6 inches after compaction. Bedding below electrical ducts shall extend the full width of the trench.
- B. Existing underground structures, tunnels, conduits and pipes crossing the excavation shall be bedded with compacted select fill material. Place bedding material under and around each existing underground structure, tunnel, conduit or pipe and extend underneath and on each side to a distance equal to the depth of the trench below the structure, tunnel, conduit or pipe.
- C. Cast-in-place manhole bases and other foundations for structures shall be cast against a concrete work mat in clean and dry excavations, unless otherwise shown, specified or required.

### 3.03 PIPE BEDDING AND INITIAL BACKFILL

- A. Place select fill by hand for initial pipe backfill from top of bedding to 1 foot over top of pipes in uniform layers not greater than 6 inches in loose thickness.

## GENERAL SPECIFICATION 02317 BACKFILLING

---

Tamp under pipe haunches and thoroughly compact in place the select fill with suitable mechanical or pneumatic tools to not less than 95 percent of the maximum dry density as determined by ASTM D1557.

- B. Do not place stone fragments larger than 2-inch size in the pipe bedding or in the backfill to 1 foot over the top of pipes, nor any stone fragments larger than 3-inch size nearer than 2 feet from any pipe, conduit or concrete wall.
- C. Pipe bedding containing very fine sand, uniformly graded sands and gravels, or other materials that have a tendency to flow under pressure when wet is unacceptable.
- D. Bed pipelines or electrical ducts placed in short tunnels in select fill, flowable fill, or 2500 psi concrete. Completely fill the remainder of the annular space between the outside of the pipe wall and the tunnel wall with select fill, flowable fill, suitable job-excavated material, or 2500 psi concrete, as approved. Pipes and ducts in short tunnels shall be supported to permit placing and compaction of backfill.

### 3.04 PLACEMENT OF FLOWABLE FILL

- A. Flowable fill shall be batched and premixed by an approved producer, dispensed from ready-mix trucks, and placed by approved methods and equipment.
- B. Flowable fill shall be placed so as to completely fill the space to receive it with no trapped air pockets or other voids. Positive means of allowing air to escape shall be provided where necessary. Where placed against and around existing structures, lift heights shall be limited so as not to overload the structure. Lift heights shall be as approved by the Engineer.
- C. Where flowable fill is placed around piping and other elements subject to floating within the fill, positive means shall be taken to provide temporary balancing loads to prevent uplift, or fill lift heights shall be limited to prevent uplift.
- D. Application of loads or placement of other fill materials or concrete on top of flowable fill shall not occur until the flowable fill surface is determined to be suitable for loading per ASTM D6024.

### 3.05 TRENCH BACKFILL

- A. Backfill trenches from 1 foot over the top of the pipe, from the top of electrical duct bedding or as shown to the bottom of pavement base course, subgrade for lawns or lawn replacement, to the top of the existing ground surface or to such other grades as may be shown or required. Backfill trenches as soon as, in the opinion of the Engineer, it can be done without injury to the concrete or pipe lines.

## GENERAL SPECIFICATION 02317 BACKFILLING

---

- B. Provide select fill, suitable job-excavated material or other material, as specified and as approved for trench backfill.
- C. Depth of Placement - General: Except under pavements, walkways, railroad tracks, and street or highway appurtenances, or as otherwise specified, place trench backfill in uniform layers not greater than 9 inches in loose thickness and thoroughly compact in place using suitable mechanical or pneumatic equipment. Compact backfill to not less than 90 percent of the maximum dry density as determined by ASTM D1557.
- D. Depth of Placement - Traffic Areas and Under Utilities: Where pavements, walkways, railroad tracks and street or highway appurtenances are to be placed over trenches and under utilities or utility services crossing the trench, provide trench backfill using select fill placed in uniform layers not greater than 9 inches in loose thickness and thoroughly compacted in place with equipment as specified above. Compact backfill to not less than 95 percent of the maximum dry density as determined by ASTM D1557.
- E. Depth of Placement - Undeveloped Areas: In undeveloped areas and where select fill material or hand-placed backfill are not specified or required, place suitable job-excavated material or other approved backfill in lifts not exceeding 12 inches in loose thickness. When the trench is full, consolidate the backfill by jetting, spading, tamping or puddling to ensure complete filling of the excavation. Mound the top of the trench approximately 12 inches to allow for consolidation of backfill.
- F. Backfill trenches in such a way as to prevent dropping material directly on top of any conduit or pipe through any great vertical distance. Do not allow backfilling material from a bucket to fall directly on a structure or pipe and, in all cases, lower the bucket so that the shock of falling earth will not cause damage.
- G. Break up lumps and distribute any stones, pieces of crushed rock or lumps which cannot readily be broken up, throughout the mass so that all interstices are solidly filled with fine material.
- H. Retain backfill in trenches by temporary bulkheads only and remove them as the backfilling progresses. Do not make bulkheads of stone.
- I. Do not cover sewers, drains, basin connections, ends of sewers and branches until the Engineer orders or gives permission to backfill.
- J. After completion of backfilling in City streets, remove all surplus material, and regrade and leave free, clear, and in good order all roadways and sidewalks. Deposit and compact a temporary surface of asphalt, or other equivalent and suitable material to a depth of six inches on all backfilled areas where ordered by the Engineer in writing. Until areas are restored to their original condition, maintain the surface of the temporary pavement in good and safe condition and



## GENERAL SPECIFICATION 02317 BACKFILLING

---

promptly fill all depressions caused by settlement of the backfill with the temporary surfacing materials and compact the same. Wet the temporary surface by spraying with water when necessary to prevent a dust nuisance.

### 3.06 STRUCTURE BACKFILL

- A. Backfill excavations as soon as, in the opinion of the Engineer, it can be done without injury to the concrete or structures.
- B. Use select fill underneath all structures, and adjacent to structures where pipes, connections, electrical ducts and structural foundations are to be located within this fill. Use select fill beneath all pavements, walkways, and railroad tracks, and extend to the bottom of pavement base course or ballast.
  - 1. Place select fill in uniform layers not greater than 8 inches in loose thickness and thoroughly compact in place with suitable approved mechanical or pneumatic equipment.
  - 2. Compact select fill to not less than 95 percent of the maximum dry density as determined by ASTM D1557.
- C. When specified in the Detailed Specifications, shown on the Contract Drawings, or approved by the Engineer, lightweight fill shall be used to raise the grade in areas that are to support pavements, walkways, railroad tracks and other structures.
  - 1. Place lightweight fill in uniform horizontal layers not greater than 12 inches in loose thickness.
  - 2. Lightweight fill shall be compacted by four complete coverages with an approved smooth drum vibratory roller having a minimum static weight of 14,000 pounds, a minimum dynamic force of 23,000 pounds, and a total force not less than 5,500 pounds per foot of compactor drum width.
- D. Use of common granular fill adjacent to structures in all areas not specified above, unless otherwise shown or specified. Select fill may be used in place of common granular fill at no additional cost.
  - 1. Extend such backfill from the bottom of the excavation or top of bedding to the underside of the lawn mix for seeded, sodded or hydroseeded areas, the top of previously existing ground surface or to such other grades as may be shown or required.
  - 2. Place backfill in uniform layers not greater than 8 inches in loose thickness and thoroughly compact in place with suitable equipment, as specified above.
  - 3. Compact backfill to not less than 90 percent of the maximum dry density as determined by ASTM D1557.

## GENERAL SPECIFICATION 02317 BACKFILLING

---

- E. In unpaved areas adjacent to structures, for the top 1 foot of fill directly under the lawn mix, use cohesive backfill conforming to Article 2.04C, placed in 6-inch lifts. The cohesive backfill shall extend to the limits of the excavated area. Compact to not less than 90 percent of the maximum dry density as determined by ASTM D1557.
- F. When shown on the Contract Drawings or specified in the Detailed Specifications, flowable fill shall be used for backfilling of structures. Backfilling with flowable fill shall be as specified in Article 3.04.
- G. When sheeting is withdrawn, solidly fill all cavities in or adjoining the trench or other excavation. When sheeting is left in place, solidly fill all cavities behind such sheeting.

### 3.07 DRAINAGE BLANKET

- A. Provide a drainage blanket consisting of drainage fill where shown, specified, or required. Place drainage fill in uniform layers not greater than 8 inches in loose thickness.
- B. Where drainage fill is required underneath structures or adjacent to structures where pipes, connections, electrical ducts and structural foundations will be located within the fill, compact the fill with suitable mechanical or pneumatic equipment to not less than 95 percent of the maximum dry density as determined by ASTM D1557.
- C. Where drainage fill is required in areas not specified in Paragraph 3.08B, compact with suitable mechanical or pneumatic equipment to not less than 90 percent of the maximum dry density as determined by ASTM D1557.

### 3.08 EARTH EMBANKMENTS

- A. Make all earth embankments of approved cohesive common fill material.
- B. Place fill in uniform layers not greater than 10 inches in loose thickness. Compact in place with suitable approved mechanical equipment.
- C. Compact earth embankments to not less than 90 percent of the maximum dry density as determined by ASTM D1557.
- D. Do not use cohesionless, granular material as earth embankment backfill, unless otherwise shown or required.

### 3.09 COMPACTION EQUIPMENT

- A. Equipment and Methods: Perform all compaction with suitable approved equipment and methods.
- B. Compact clay and other cohesive material with sheep's-foot rollers or similar equipment where practicable. Use hand held pneumatic tampers elsewhere for compaction of cohesive fill material.

## GENERAL SPECIFICATION 02317 BACKFILLING

---

- C. Compact low cohesive soils with pneumatic-tire rollers or large vibratory equipment where practicable. Use small vibratory equipment elsewhere for compaction of cohesionless fill material.
  - D. Do not use heavy compaction equipment over pipelines or other structures, unless the depth of fill is sufficient to adequately distribute the load.
- 3.10 FINISH GRADING
- A. Perform finish grading in accordance with the completed contour elevations and grades shown on the Contract Drawings and blend into conformation with remaining natural ground surfaces.
    - 1. Leave all finished grading surfaces smooth and firm to drain. Areas shall be finished to the degree obtainable by either blade or scraper operations and suitable for application of topsoil.
    - 2. Bring finish grades to elevations within plus or minus 0.10 foot of elevations or contours shown.
    - 3. Areas which are anticipated to be undisturbed for a period of more than 30 days shall receive temporary seeding of rye grass at a rate of three bushels per acre, weather and season permitting. This seeding shall be repeated as necessary to maintain a continuing ground cover.
  - B. Grade outside of building or structure lines in a manner to prevent accumulation of water within the area. Where necessary or where shown, extend finish grading to ensure that water will be carried to drainage ditches, and the site area left smooth and free from depressions holding water.
- 3.11 FIELD QUALITY CONTROL
- A. Sampling and Testing of Select, Common and Lightweight Backfill:
    - 1. Provide sampling, testing, and laboratory methods in accordance with ASTM D1556 or other method as determined by the Engineer for select fill and common fill.
    - 2. Lightweight fill shall be tested as described in Paragraph 2.06C in accordance with ASTM D698.
    - 3. Subject all backfill to these tests to the satisfaction of the Engineer. These tests shall be the basis for acceptance or rejection by the Engineer of the compaction. Failure to achieve the specified densities shall require the Contractor to recompact or remove the material as required.
  - B. Sampling and Testing of Flowable Fill:
    - 1. The Contractor shall provide all facilities as may be necessary for the ready procurement of samples of flowable fill from the Work or truck mixers as required by the Engineer for test purposes.

## GENERAL SPECIFICATION 02317 BACKFILLING

---

2. The DEP/QA/QC Consultant will provide personnel and equipment for making periodic determinations in the field of slump, air content, ambient and concrete temperature, unit weight and yield and for the preparation of compressive strength test cylinders as required in compliance with applicable ASTM tests and procedures. In compliance with ASTM D4832, a minimum of two cylinders will be tested at 7 days, two at 28 days, and three at 56 days. Tests shall be made on material at point of discharge into the work. Tests shall be made for each 200 cubic yards of material placed but not less than one test for each day flowable fill is placed.
  3. The Contractor shall supply all equipment necessary to perform the required tests including, but not limited to, cylinder molds, tags, capping compound, slump cones, platform scale, two buckets (each 2 cubic feet in size), thermometers, pressure air meter, and roller meter.
- C. Correction of Work:
1. Correction of Work: Correct any areas of unsatisfactory compaction by removal and replacement, or by scarifying, aerating or sprinkling as needed and recompaction in place prior to placement of a new lift. The Contractor shall, if necessary, increase the compactive effort by increasing the number of passes, using heavier or more suitable compaction equipment, or by reducing the lift thickness. The Contractor shall adjust the moisture content of the soil to bring it to the optimum range by drying or adding water, as required.
  2. Correct any depression which may develop from settlement in backfilled areas within one year after the work is fully completed. Provide, as needed, backfill material, pavement base replacement, permanent pavement, sidewalk, curb and driveway repair or replacement, and lawn replacement, and perform the necessary reconditioning and restoration work to bring such depressed areas to proper grade as approved.

END OF SECTION

**GENERAL SPECIFICATION 2318 ROCK EXCAVATION**

---

**SECTION 02318  
Rock Excavation**

**PART 1 GENERAL**

**1.01 SECTION INCLUDES**

- A. This Section describes the excavation and disposal of all material as specified here or shown on the Contract Drawings, for the purpose of building structures, conduits, pipe lines and other structures as well as grading and completing the work in every respect.
- B. The following index of this Section is included for convenience:

<u>Article</u>	<u>Title</u>	<u>Page</u>
		02318-
PART 1	GENERAL.....	1
1.01	Section Includes.....	1
1.02	Payment.....	1
1.03	Related Sections.....	2
1.04	Definition.....	2
1.05	Submittals.....	2
PART 2	PRODUCTS (NOT USED).....	2
PART 3	EXECUTION.....	2
3.01	Notification Of Engineer To Measure Rock.....	2
3.02	Shaping And Trimming.....	2
3.03	Blasting.....	3
3.04	Prevention Of Dust Hazard.....	3
3.05	Overbreakage And Unauthorized Excavation.....	3
3.06	Additional Excavation.....	3
3.07	Sheeting, Bracing And Underpinning.....	3
3.08	Fencing, Bridging And Decking.....	3
3.09	Removal Of Water.....	4
3.10	Disposal Of Excavated Material.....	4
3.11	Sheeting Left In Place.....	4

**1.02 PAYMENT**

- A. The quantity, in cubic yards, to be measured for payment shall be the volume of rock excavated between the top surface of the rock and the payment lines or planes shown, indicated or specified.
- B. Where rock excavation is not begun from the top surface of the rock, as in tunnel construction, such excavation will be measured between the payment lines or planes shown, indicated or specified.

## GENERAL SPECIFICATION 2318 ROCK EXCAVATION

---

- C. Where no payment line or plane is shown on the Contract Drawings or specified, or where the Engineer orders additional rock excavation, such excavation shall be measured between planes six inches outside of and parallel to the true face lines of the structure or the limits of work established for additional excavation and the surface of the rock.
- D. Rock excavation will be paid for as provided in the Detailed Specifications.
- E. Payment for sheeting and bracing ordered left in place will be made as provided in the Detailed Specifications.
- F. No separate payment will be made for unauthorized excavations, for the disposal of such excavated materials, nor for the refilling of such excavations with suitable material or concrete.

### 1.03 RELATED SECTIONS

- A. General Specification 02240 - Dewatering
- B. General Specification 02250 - Shoring and Underpinning
- C. General Specification 02316 - Excavation

### 1.04 DEFINITION

- A. The word "rock" as used here includes all materials requiring barring or wedging for their removal from their original beds and specifically includes all ledge or bed rock and boulders or masonry larger than one-half cubic yard in volume, but excludes pavements and pavement foundations.

### 1.05 SUBMITTALS

- A. Before proceeding with any excavation work, obtain all necessary permits required by City Departments having jurisdiction and all written consents from owners of private property affected by the prosecution of the work, which may necessitate temporary or permanent occupation, easements, storage of materials, or other physical encroachments.

## PART 2 PRODUCTS (NOT USED)

## PART 3 EXECUTION

### 3.01 NOTIFICATION OF ENGINEER TO MEASURE ROCK

- A. Notify the Engineer before commencing rock excavation. The Engineer will measure or cross-section the rock. Rock removed before being measured or cross-sectioned will not be paid for.

### 3.02 SHAPING AND TRIMMING

- A. Make all excavations of adequate size to properly construct the structures in the manner and of the size specified and shown on the Contract Drawings, and to remove any material, which the Engineer may deem unsuitable for foundations.

## GENERAL SPECIFICATION 2318 ROCK EXCAVATION

---

Whenever the nature of the ground will permit, form the bottom to the shape and dimensions of the outside of the masonry. In order to secure this shape provide proper templates, firmly set and held to the proper line and grade.

### 3.03 BLASTING

- A. Unless otherwise permitted in the Detailed Specifications, no blasting will be allowed.

### 3.04 PREVENTION OF DUST HAZARD

- A. Provide for the installation, maintenance and effective operation of appliances and methods for the elimination of harmful dust which have been approved by the Industrial Board of the Department of Labor of the State of New York, as provided in Section 222-a of the Labor Law. If the provisions of said Section 222-a are not complied, this Contract shall be void.

### 3.05 OVERBREAKAGE AND UNAUTHORIZED EXCAVATION.

- A. All overbreakage and unauthorized excavation carried outside the lines and grades given, except as hereinafter specified, together with the removal of the excavated materials, shall be at the Contractor's expense. Backfill unauthorized excavations as directed with compacted, suitable material, except for unauthorized excavations under structures, which shall be refilled with Class 15 concrete, unless otherwise permitted by the Engineer.

### 3.06 ADDITIONAL EXCAVATION

- A. Excavate outside the established lines only when authorized in writing by the Engineer.

### 3.07 SHEETING, BRACING AND UNDERPINNING

- A. Where required, support the sides of excavations with adequate sheeting and bracing. Where the character of rock, boulders or masonry in excavation is such as to render it necessary, closely drive the sheeting. Support structures requiring underpinning before the general excavation is started. Sheeting, underpinning and bracing shall conform to the requirements of General Specification 02250 – Shoring and Underpinning.

### 3.08 FENCING, BRIDGING AND DECKING

- A. Immediately enclose excavations in a public street, park or place, or in property adjoining the site with a satisfactory guard fence. When a tight board fence is specified, no guard fence will be required, provided there is no delay in the erection of the tight board fence.
- B. Where required for vehicular traffic, construct a substantial timber bridge, with side railings, across the excavation to permit the passage of vehicles.
- C. Construct substantial temporary foot bridges, with side rails, wherever required by the Engineer.

## GENERAL SPECIFICATION 2318 ROCK EXCAVATION

---

- D. At street intersections, provide substantial decking for traffic over excavations made from the surface. Maintain decking at all times except as hereinafter specified. The Contractor shall be fully responsible for the adequacy of the decking. Remove pavement and place decking during hours of day or night, which will cause the least inconvenience to adjoining property owners, to the public, and to traffic in general. During certain designated hours of the day or night, sections of planking not more than ten feet in length may be temporarily removed for the purpose of the excavating operations.
- E. Obtain approval from the Engineer for designs for all fencing, bridging and decking before erection.

### 3.09 REMOVAL OF WATER

- A. At all times during the construction of the work and until final acceptance thereof, provide and maintain ample means and equipment with which to promptly remove and properly dispose of water and sewage entering the excavations or other parts of the work, and keep said excavations dry until the structures to be built therein are completed and backfilled to the level of ground water except where otherwise approved by the Engineer in writing. Dewatering and disposal of water shall conform to the requirements of General Specification 02240 - Dewatering.

### 3.10 DISPOSAL OF EXCAVATED MATERIAL

- A. Dispose of excavated material not required or permitted to be used for backfilling in accordance with General Specification 02316 - Excavation.

### 3.11 SHEETING LEFT IN PLACE

- A. Cut off at the elevations ordered all sheeting or bracing ordered in writing by the Engineer to be left in place in accordance with General Specification 02316 – Excavation. In general, such cut-offs shall not be less than 18 inches below the final ground surface. Do not remove sheeting without first securing the permission of the Engineer. Give particular attention to securing the stability of footings, which parallel and lie close to the excavation work.
- B. The Contractor shall be fully responsible for injury to structures, property, or persons resulting from failure to leave in place sufficient sheeting and bracing.

END OF SECTION



**GENERAL SPECIFICATION 02371 DUST, SOIL EROSION AND  
SEDIMENTATION CONTROL**

---

**SECTION 02371  
Dust, Soil Erosion and Sedimentation Control**

**PART 1 GENERAL**

**1.01 SECTION INCLUDES**

- A. The Contractor shall provide all labor, materials, tools, equipment, and incidentals required to assure adequate environmental protection including implementation of all erosion and sediment control measures and maintenance of storage areas as directed by the Engineer.
- B. The Contractor shall provide an Erosion and Sedimentation Control Plan (E&SCP) that establishes methods and procedures to prevent migration of contaminated stormwater and sediment and to prevent erosion of features of the Work.
- C. The Contractor shall minimize erosion and prevent discharge of sediment to surface water features, watercourses, drainage systems, public streets or private property from construction activities. The Contractor shall provide methods to prevent construction activities from generating contaminated stormwater runoff. Methods of constructing berms and dikes to direct clean stormwater runoff around the work area to the local drainage system shall be included.
- D. The Contractor shall comply with all Federal, State, or local laws, codes, ordinances, and regulations which govern the control of sediment, erosion, and stormwater during construction activities.
- E. The Contractor shall provide Best Management Practices (BMPs) including, but not limited to silt fences, straw bales, diversion dikes, swales, sedimentation basins/traps, truck wash areas/decontamination stations, stabilized construction entrances and/or other means as a temporary structural practice to minimize erosion and sediment runoff.
- F. The Contractor shall provide and implement, if applicable, a Stormwater Pollution Prevention Plan (SWPPP) prepared in accordance with the current New York State Department of Conservation (NYSDEC) State Pollutant Discharge Elimination System (SPDES) General Permit for Stormwater Discharges from Construction Activity unless otherwise specified in the Detailed Specification. For activities in the New York City Water Supply watershed, the Contractor shall provide and implement, if applicable, a Stormwater Pollution Prevention Plan (SWPPP) prepared in accordance with the current Rules and Regulations for the Protection from Contamination, Degradation, and Pollution of the New York City Water Supply and its Sources (Watershed Regulations).
- G. If applicable, the SWPPP shall be prepared in accordance with the existing SWPPP for the site/facility. The Contractor shall coordinate with the Operating

**GENERAL SPECIFICATION 02371 DUST, SOIL EROSION AND  
SEDIMENTATION CONTROL**

---

Bureau to review the Operating Bureau’s existing SWPPP and address all requirements as applicable.

- H. The Contractor shall control dust caused by operation and movement of vehicles and equipment in accordance with the latest DEP and OSHA standards, and all other applicable Federal, State and local regulations.
- I. The following index of this Section is included for convenience:

<u>Article</u>	<u>Title</u>	<u>Page</u>
		02371-
PART 1	GENERAL.....	1
1.01	Section Includes.....	1
1.02	Payment.....	2
1.03	Related SECTIONS.....	2
1.04	References.....	3
1.05	Definitions.....	3
1.06	Submittals.....	3
1.07	Quality Assurance.....	6
1.08	Environmental Requirements.....	8
1.09	Project Conditions.....	9
1.10	Storage, Handling and Removal.....	9
PART 2	PRODUCTS.....	10
2.01	Materials.....	10
PART 3	EXECUTION.....	10
3.01	Installation and Maintenance.....	10
3.02	Stockpiling.....	10
3.03	Field Quality Control.....	12
3.04	Cleaning.....	12

1.02 PAYMENT

- A. Unless otherwise provided in the Detailed Specifications, no separate payment will be made for performing any Work required under this Section and the Contract shall include all costs thereof in its lump sum price bid for the Contract.

1.03 RELATED SECTIONS

- A. General Specification 02105 - Soil Sampling and Analysis
- B. General Specification 02230 - Site Clearing
- C. General Specification 02240 - Dewatering
- D. General Specification 02316 - Excavation

**GENERAL SPECIFICATION 02371 DUST, SOIL EROSION AND  
SEDIMENTATION CONTROL**

---

1.04 REFERENCES

- A. Comply with applicable provisions and recommendations of the following except as otherwise shown or specified.
  - 1. NYSDEC SPDES General Permit for Stormwater Discharges from Construction Activity (GP-0-15-002, or latest version)
  - 2. New York City Watershed Regulations (April 4, 2010, or latest version)
  - 3. New York State Standards and Specifications for Erosion and Sediment Control (aka “Blue Book”) (NYSDEC, Aug 2005, or latest version)
  - 4. New York State Stormwater Management Design Manual (latest version)

1.05 DEFINITIONS

- A. Best Management Practices: Physical, structural, and/or managerial practices that, when used singly or in combination, prevent or reduce pollution of water, and have been approved by DEP or NYSDEC.
- B. Commencement of Construction: The initial disturbance of soils associated with clearing, grading or excavation activities; or other construction related activities that disturb or expose soils such as demolition, stockpiling of fill material, and the initial installation of erosion and sediment control practices.
- C. Erosion: The wearing away of the land surface by running water, wind, ice, or other geological agents, including such processes as geological creep, detachment, movement of soil or rock fragments by water, wind, ice, or gravity.
- D. Erosion/Sediment Control: Any temporary or permanent measures taken to reduce erosion, control siltation and sedimentation, and ensure that sediment-laden water does not leave the site.
- E. Final Stabilization: All soil-disturbing activities at the site have been completed and uniform, perennial vegetative cover with the density of eighty (80) percent has been established or equivalent stabilization measures (such as the use of mulches or geo-textiles) have been employed on all unpaved areas and areas not covered by permanent structures, concrete or pavement.
- F. Receiving Waters: Bodies of water or surface water systems receiving water from upstream manmade (or natural) streams
- G. Sediment: Fragmented material that originates from weathering and erosion of rocks and unsolicited deposits, and is transported by, suspended in, or deposited in water.

1.06 SUBMITTALS

- A. The Contractor shall submit Shop Drawings and other documentation, required to show conformance to the requirements of the Contract Drawings, for the

## GENERAL SPECIFICATION 02371 DUST, SOIL EROSION AND SEDIMENTATION CONTROL

---

approval to the Engineer. Shop Drawings shall show details of the Sediment and Stormwater Control System. The Submittals shall include, but not limited to the following:

1. Plan locations of all components of the Sediment/Stormwater Control System.
  2. Details of all applicable BMPs (e.g., silt fence, diversion dike, straw bale berm, decontamination stations, etc.).
  3. All of the planned components of the Erosion and Sediment Control Plan, as detailed below in Paragraph B.
  4. All components of the SWPPP to be constructed on site, as detailed in Paragraph C below.
  5. The Contractor shall submit manufacturer's descriptive literature and installation instructions for stockpile liner and cover material as specified in Paragraph 2.01.B and Part 3.02.
- B. Erosion and Sediment Control Plan (E&SCP): The Contractor shall develop and submit to the Engineer for approval, prior to commencement of construction activities, an E&SCP. The E&SCP shall address schedules and measures that will be taken to prevent migration of contaminated stormwater/sediment, and to prevent erosion of features of the Work. The E&SCP shall include the following at a minimum:
1. Measures to capture and mitigate stormwater runoff from active, disturbed areas.
  2. Provisions for silt fences and other measures to limit migration of sediments.
  3. Provisions for straw bale berms and silt fences or other measures to prevent contaminant and sediment migration.
  4. Diversion of stormwater: The Contractor shall include provisions for controlling stormwater runoff in and around excavation areas.
  5. Soil Storage Area: All details of temporary soil storage to be implemented as specified in this section.
  6. Soil Stabilization Practices: All details of soil stabilization practices to be implemented, as specified in this section.
  7. Provisions for all other applicable Best Management Practices.
- C. The Contractor shall develop and submit to the Engineer for approval a SWPPP prepared by a Qualified Professional in accordance with the requirements of the current NYSDEC SPDES General Permit for Stormwater Discharges from Construction Activity unless otherwise specified in the Detailed Specification. For activities in the New York City Water Supply watershed, the Contractor

## GENERAL SPECIFICATION 02371 DUST, SOIL EROSION AND SEDIMENTATION CONTROL

---

shall provide and implement, if applicable, a Stormwater Pollution Prevention Plan (SWPPP) prepared in accordance with the current Rules and Regulations for the Protection from Contamination, Degradation, and Pollution of the New York City Water Supply and its Sources (Watershed Regulations). The SWPPP shall be developed and submitted to the Engineer for approval prior to the initiation of construction activities. The SWPPP shall include the following at a minimum:

1. Provide background information about the scope of the project, including the location, type and size of project;
2. Provide a site map for the project, including a general location map. The site map should show the total site area; all improvements; areas of disturbance; areas that will not be disturbed; existing vegetation; on-site and adjacent off-site surface water(s), wetlands and drainage patterns that could be affected by the construction activity; existing and final slopes; locations of off-site material, waste, borrow or equipment storage areas; and location(s) of the stormwater discharge(s);
3. Provide a map and a description of the soil(s) present at the site;
4. Provide a Construction Phasing Plan describing the intended sequence of construction activities, including clearing and grubbing, excavation and grading, utility and infrastructure installation and any other activity at the site that results in soil disturbance. Consistent with the NYSDEC SPDES General Permit for Stormwater Discharges from Construction Activity (GP-0-15-002 or latest version), there shall not be more than five (5) acres of disturbed soil at any one time without prior written approval from the NYSDEC;
5. Provide a description of the pollution prevention measures that will be used to control litter, construction chemicals and construction debris from becoming a pollutant source in the stormwater discharges;
6. Provide a description of construction and waste materials expected to be stored on-site with updates as appropriate, and a description of controls to reduce pollutants from these materials including storage practices to minimize exposure of the materials to stormwater, and spill prevention response;
7. Describe the temporary and permanent structural and vegetative measures to be used for soil stabilization, runoff control and sediment control for each stage of the project from initial land clearing and grubbing to project closeout;
8. Identify and show on a site map the specific location(s), size(s), and length(s) of each erosion and sediment control practice;

## GENERAL SPECIFICATION 02371 DUST, SOIL EROSION AND SEDIMENTATION CONTROL

---

9. Provide the dimensions, material specifications, and installation details for all erosion and sediment control practices, including the siting and sizing of any temporary sediment basins;
  10. Identify temporary practices that will be converted to permanent control measures;
  11. Provide an implementation schedule for staging temporary erosion and sediment control practices, including the timing of initial placement and the placement and the duration that each practice should remain in place;
  12. Provide a maintenance schedule to ensure continuous and effective operation of the erosion and sediment control practices;
  13. Provide the name(s) of the receiving water(s);
  14. Provide a delineation of SWPPP implementation responsibilities for each part of the site;
  15. Provide a description of structural practices to divert flows from exposed soils, store flows, or otherwise limit runoff and the discharge of pollutants from exposed areas of the site to the degree attainable; and
  16. Provide any existing data that describes the stormwater runoff characteristics at the site.
- D. Inspection Reports: The Contractor shall conduct inspections and submit inspection reports consistent with requirements of the NYSDEC SPDES General Permit for Stormwater Discharges from Construction Activity (GP-0-15-002 or latest version) including:
1. Site inspections shall be conducted by the Qualified Inspector.
  2. Site inspections are conducted a minimum of once every seven (7) calendar days and twice every seven (7) calendar days for sites with greater than 5 acres of soil disturbance. The two (2) inspections shall be separated by a minimum of two (2) full calendar days.
  3. Inspection reports shall be maintained in a logbook at the site with SWPPP and other required documentation.

### 1.07 QUALITY ASSURANCE

- A. Permits and Regulations:
1. The Contractor shall obtain all necessary permits and be responsible for implementing the terms and requirements of these permits as needed and for payment of all fees.
  2. The Contractor shall handle all material in compliance with applicable requirements of OSHA and other governing authorities having jurisdiction.

**GENERAL SPECIFICATION 02371 DUST, SOIL EROSION AND  
SEDIMENTATION CONTROL**

---

3. Certifications. The Contractor must sign a copy of the certification statements below, as provided in GP-0-15-002 (or certifications in latest version), before undertaking any construction activity at the site identified in the SWPPP. All certifications must be included in the SWPPP.
  - a. “I hereby certify that I understand and agree to comply with the terms and conditions of the SWPPP and agree to implement any corrective actions identified by the qualified inspector during a site inspection. I also understand that the NYCDEP must comply with the terms and conditions of the New York State Pollutant Discharge Elimination System ("SPDES") General Permit for Stormwater Discharges from Construction Activity (GP-0-15-002, or latest version) and that it is unlawful for any person to cause or contribute to a violation of water quality standards. Furthermore, I understand that certifying false, incorrect or inaccurate information is a violation of the referenced permit and the laws of the State of New York and could subject me to criminal, civil and/or administrative proceedings.”
  - b. The certification statements must include the name and title of the person providing the signature, address and telephone number of the contracting firm, the address of the site, and the date the certification is made. The certification must be signed by an authorized representative of the firm.
4. Inspections. The Contractor must have a qualified inspector conduct an assessment of the site prior to the commencement of construction and certify in an inspection report that the appropriate erosion and sediment controls described in the SWPPP have been adequately installed or implemented to ensure overall preparedness of the site for the commencement of construction. Following commencement of construction, site inspections shall be conducted at least once every seven (7) calendar days and twice a week for sites with soil disturbance greater than 5 acres unless otherwise specified in the Detailed Specification. The two (2) inspections shall be separated by a minimum of two (2) full calendar days. The inspection reports must be kept on file at the construction site with the SWPPP, if applicable, for review by a NYSDEC inspector.
5. Stabilization. The contractor shall initiate stabilization measures as soon as practicable in portions of the site where construction activities have temporarily or permanently ceased.
6. If a SWPPP is required, it shall be kept current on file at the construction site for review by a NYSDEC inspector. If there is a significant change

## GENERAL SPECIFICATION 02371 DUST, SOIL EROSION AND SEDIMENTATION CONTROL

---

in construction which may have a significant effect on the potential for the discharge of pollutants to surface waters of the State and which has not otherwise been addressed in the SWPPP, it would require that the SWPPP be updated to reflect those required changes. The SWPPP would also require an amendment if the SWPPP proves to be ineffective in eliminating or significantly minimizing pollutants from sources identified in the SWPPP or achieving the general objectives of controlling pollutants in stormwater discharges from permitted construction activity. Additionally, the SWPPP shall be amended to identify any new subcontractor and their associated responsibilities.

### 1.08 ENVIRONMENTAL REQUIREMENTS

- A. **Soil Stabilization:** The stabilization practices to be implemented shall include one or a combination of the following: temporary seeding, mulching, geotextiles, sod stabilization, vegetative buffer strips, erosion control mats, protection of trees and shrubs, preservation of mature vegetation. Protection of trees shall be in accordance with General Specification 02230 – Site Clearing. Stabilization practices shall be implemented as approved by the Engineer. The Contractor shall record the dates when the major grading activities occur (i.e. clearing and grubbing, excavation, embankment and grading); when construction activities temporarily or permanently cease on a portion of the site; and when stabilization practices are initiated. Except as provided in paragraphs 1.08A.1 and 1.08A.2 below, stabilization practices shall be initiated as soon as practicable, but no more than fourteen (14) days after construction activities have temporarily or permanently ceased.
1. **Unsuitable Conditions:** Where the initiation of stabilization measures by the fourteenth day after construction activity temporarily or permanently ceases is precluded by unsuitable conditions caused by the weather. Stabilization practices shall be initiated as soon as practicable after conditions become suitable.
  2. **Temporary Inactivity Less than 14 Days:** Where construction activity will resume on a portion of the site within 14 days after it temporarily ceases, no stabilization practices will be required.
- B. **Erosion and Sediment Control:** Erosion and Sediment control BMPs shall be operational at all times during the Work, specifically during excavation, backfilling and restoration, and decontamination operations. The sediment and erosion control system shall be capable of handling stormwater during construction. Damage to excavation slopes and the migration of contaminated soil to downstream areas resulting from storm events shall be repaired or remediated by the Contractor, at the Contractor's expense.
- C. **Stormwater:** At no time shall the Contractor allow stormwater runoff from soil excavation/stockpiling operations, or effluent from decontamination operations



## GENERAL SPECIFICATION 02371 DUST, SOIL EROSION AND SEDIMENTATION CONTROL

---

to migrate off to contaminate soils in other areas or percolate into the groundwater. The Engineer will monitor any overflow or leakage that occurs, and may at his discretion require the Contractor to perform soil sampling within all areas affected by such overflow. Any soils that have been contaminated by such overflow shall be removed, treated and disposed of by the Contractor at no additional cost to the City. All sampling and analyses of soils required to determine the contamination or remediation of these soils shall be performed in accordance with General Specification 02105 – Soil Sampling and Analysis.

- D. Disposal of Water: Water collected from decontamination areas and dewatering operations shall be handled in accordance with General Specification 02240 - Dewatering.

### 1.09 PROJECT CONDITIONS

- A. Existing Work: All BMPS (e.g., silt fences, straw bales, swales, sumps, pumps, piping) and other sediment/stormwater controls shall be installed such that other aspects of the Work are not adversely impacted or endangered. All installations shall be subject to the approval of the Engineer.
- B. Dust Control: The Contractor shall be responsible for controlling visible dust caused by Work operations and the moving of vehicles and equipment. Dust control shall be implemented when soils are exposed, before, during and after Work activity ceases. Dust control will also be required on the weekends. The Contractor shall utilize the application of water or other methods, subject to the Engineer's approval, when visible dust is present on-site, in accordance with the Health and Safety Plan. The use of chemicals for dust control, including calcium chloride, will not be permitted.
  - 1. All excavation, loading and transport of materials shall minimize the formation of dust and shall conform to General Specification 02316 - Excavation. To prevent dust generation, application of water to roadways and active work areas shall be utilized as required. The Contractor's operations shall include air monitoring and dust minimization measures, consistent with the Detailed Health and Safety Plan (HASP) Specifications.
- C. Silt and Sediment Disposal: All silt and sediment which accumulates behind any BMPs used on the site (i.e., straw bale berms or silt fences) shall be removed and disposed of off-site in accordance with all applicable Federal, State and local regulations.

### 1.10 STORAGE, HANDLING AND REMOVAL

- A. The Contractor shall store, handle, and remove material and equipment consistent with requirements of the SWPPP and NYSDEC SPDES General Permit for Stormwater Discharges from Construction Activity (Permit No. GP-0-15-002) or latest version.

**GENERAL SPECIFICATION 02371 DUST, SOIL EROSION AND  
SEDIMENTATION CONTROL**

---

- B. Removal of all waste shall be in accordance with the requirements of Detailed Specifications.

**PART 2 PRODUCTS**

**2.01 MATERIALS**

- A. All components/controls must be designed in conformance with the most current version of the technical standard, New York State Standards and Specifications for Erosion and Sediment Control, and the New York State Stormwater Management Design Manual. Where erosion and sediment control practices are not designed in conformance with these technical standards, the Contractor must demonstrate equivalence to the technical standard.
- B. Stockpile cover and liner fabric shall be a composite structure of fiber-reinforced polyethylene (RPE) fabric (minimum 20-mils). The fabric shall be inert to biological degradation and naturally encountered chemicals, alkalis and acids. Its permeability coefficient shall be less than  $10^{-3}$  cm/sec.

**PART 3 EXECUTION**

**3.01 INSTALLATION AND MAINTENANCE**

- A. All installation of erosion and sediment control BMPs must be consistent with the most current version of the technical standard, New York State Standards and Specifications for Erosion and Sediment Control, and the New York State Stormwater Management Design Manual. Where erosion and sediment control practices are not designed in conformance with these technical standards, the Contractor must demonstrate equivalence to the technical standard.
- B. Maintenance: The Contractor shall maintain the temporary and permanent vegetation, erosion and sediment control measures, and other protective measures in good and effective operating condition at all times consistent with the most current version of the technical standard, New York State Standards and Specifications for Erosion and Sediment Control, and the New York State Stormwater Management Design Manual.

**3.02 STOCKPILING**

- A. Cover and Liner Requirements
  - 1. Soil Stockpiles: Stockpiles of excavated soil to be used for backfilling on-site under the NYSDEC Pre-Determined or Case-Specific BUD, or stockpiles of other soil mixes being brought onsite for landscaping purposes, shall be stored as follows:
    - a. Contaminated Soil: Stockpiles of excavated soil that are known to be or potentially could be contaminated (pending analysis), shall be lined on the bottom and covered with an impermeable, RFP fabric, as specified in 2.01.B above.

**GENERAL SPECIFICATION 02371 DUST, SOIL EROSION AND  
SEDIMENTATION CONTROL**

---

- b. Uncontaminated Soil: Stockpiles of excavated uncontaminated soil shall have a cover only; a bottom liner is not required. The cover fabric shall be as specified in 2.01.B above.
  2. Demolition Waste Stockpiles: Stockpiles of demolition waste that are to be recycled (on-site or off-site) or disposed of at a sanitary landfill shall be stored as follows:
    - a. Contaminated Demolition Waste: Stockpiles of demolition waste that are known to be or potentially could be contaminated (pending analysis), shall be lined on the bottom and covered with an impermeable, RFP fabric, as specified in 2.01.B above.
    - b. Uncontaminated Demolition Waste: Stockpiles of uncontaminated demolition waste shall have a cover only; a bottom liner is not required. The cover fabric shall be as specified in 2.01.B above.
  3. Stockpiles of materials classified as contaminated, hazardous waste shall be stored with a cover and liner as specified above for contaminated soil or contaminated demolition waste, and transported off-site promptly in DOT-approved hazardous waste shipping containers. Temporary hazardous waste storage areas shall comply with and the requirements of the Contract and applicable Federal, State and local regulations.
  4. All stockpiles shall be covered during non-working hours and during periods of no construction activity. The terminal edges of the fabric cover panels shall be secured to prevent uplift by wind.
- B. Stockpile Areas and Placement
  1. Stockpiling of excavated materials will be permitted on-site within areas as designated on the Contract Drawings for construction staging, or as directed by the Engineer. All stockpiling areas on-site must be approved by the Engineer in advance.
  2. The Contractor shall make his or her own arrangements to provide additional stockpiling area on-site or off-site, if required, for excavated material at no additional cost to the City. Additional stockpiling areas whether on-site or off-site shall be approved by the Engineer.
  3. Stockpiles of excavated material to be used for backfilling on-site under the NYSDEC Pre-Determined or Case-Specific BUD shall be so piled and placed as not to encumber sidewalks or roadways, or wash away or obstruct the free flow of surface or drainage water. Stockpiles shall be suitably bermed for run-off containment of any water that drains from the soils.

**GENERAL SPECIFICATION 02371 DUST, SOIL EROSION AND  
SEDIMENTATION CONTROL**

---

4. Stockpiles shall not be placed closer to the edge of an excavation than a distance equal to 1-1/2 times the depth of the excavation, unless the excavation is in rock or the sides of the excavation have been sloped or sheeted and shored to withstand the lateral forces imposed by such superimposed loads.

3.03 FIELD QUALITY CONTROL

- A. Inspections: Site Inspections shall be conducted consistent with the requirements of the SWPPP and the current NYSDEC SPDES General Permit for Stormwater Discharges from Construction Activity (GP-0-15-002 or latest version). The Qualified Inspector shall inspect disturbed areas of the construction site, areas used for storage of materials that are exposed to precipitation that have not been finally stabilized, stabilization practices, structural practices, other controls, areas where vehicles exit the site daily and all other requirements listed in the most current NYSDEC SPDES General Permit for Stormwater Discharges from Construction Activity (GP-0-15-002 or latest version).
- B. Inspection of soil and material stockpiles shall be done daily to ensure the integrity of the cover and liner is maintained.

3.04 CLEANING

- A. The Contractor shall clean the site and equipment consistent with requirements of the SWPPP and the current New York State Standards and Specifications for Erosion and Sediment Control. Where appropriate, truck washes/decontamination stations should be installed to minimize the migration of sediment off-site as specified in the Detailed Specifications.

END OF SECTION

**GENERAL SPECIFICATION 02372 EMBANKMENT AND CHANNEL PROTECTION**

---

**SECTION 02372  
Embankment and Channel Protection**

**PART 1 GENERAL**

**1.01 SECTION INCLUDES**

- A. Requirements for furnishing and placing a protective covering of erosion-resistant material on embankment slopes, streambanks, at culvert inlets or outlets, on bottoms and side slopes of channels, at structure foundations, and at other locations shown on the Contract Drawings or as directed by the Engineer. The work shall be done in accordance with these specifications and in conformity with the lines, grades, thicknesses, and typical sections shown on the Contract Drawings or established by the Engineer.
- B. Embankment and channel protection includes stone filling, dry riprap, grouted riprap, concrete block paving, gabions and bedding material for stone.
- C. This Section is based on Section 620 of the New York State Department of Transportation (NYSDOT) Standard Specifications.
- D. The following index of this Section is included for convenience:

<u>Article</u>	<u>Title</u>	<u>Page</u>
		02372-
PART 1	GENERAL.....	1
1.01	Section Includes.....	1
1.02	Payment.....	1
1.03	Related Sections.....	2
1.04	References.....	2
1.05	Definitions.....	2
1.06	Quality Assurance.....	3
1.07	Submittals.....	3
Part 2	Products.....	4
2.01	Materials.....	4
PART 3	EXECUTION.....	9
3.01	Installation.....	9

**1.02 PAYMENT**

- A. Unless otherwise provided in the Detailed Specifications, no separate payment will be made for performing any Work required under this Section and the Contractor shall include all costs thereof in its lump sum price bid for the Contract.

**GENERAL SPECIFICATION 02372 EMBANKMENT AND CHANNEL  
PROTECTION**

---

1.03 RELATED SECTIONS

- A. General Specification 02230 - Site Clearing
- B. General Specification 02316 - Excavation
- C. General Specification 02317 - Backfilling
- D. General Specification 02371 - Dust, Soil Erosion and Sedimentation Control

1.04 REFERENCES

- A. ASTM C88 - Standard Test Method for Soundness of Aggregates by Use of Sodium Sulfate or Magnesium
- B. ASTM C140 - Standard Test Methods for Sampling and testing Concrete Masonry Units and Related Units
- C. ASTM C150 - Standard Specification for Portland Cement
- D. American Association of State Highway and Transportation Officials (AASHTO) Standards
- E. New York State Department of Transportation (NYSDOT) Standard Specifications
- F. NYSDOT Materials Bureau, Materials Method 29

1.05 DEFINITIONS

- A. Stone Filling: Stone filling shall consist of well-graded stone placed as protective material on earth embankments, on streambanks, in channels and elsewhere, as shown, specified or required.
- B. Dry Riprap: Dry riprap shall consist of stone fitted and placed on streambanks or in channels in order to provide protection against erosion.
- C. Grouted Riprap: Grouted riprap shall consist of stone similar to dry riprap but with all spaces between the stones filled with cement grout.
- D. Bedding Material. Bedding material shall consist of granular material placed in a layer, where required, on the ground surface prior to placing stone filling or riprap. The purpose of the bedding material is to prevent underlying finer materials from passing into and through the stone filling or riprap.
- E. Concrete Block Paving: Concrete block paving shall consist of concrete blocks placed on embankment slopes under structures as protection against erosion.
- F. Cushion Sand: Cushion sand shall consist of fine aggregate placed on the ground prior to placing concrete block paving.
- G. Gabions: Gabions shall consist of open wire mesh baskets, filled with stones.

**GENERAL SPECIFICATION 02372 EMBANKMENT AND CHANNEL  
PROTECTION**

---

1.06      QUALITY ASSURANCE

- A.      The soundness of all material used for stone filling, riprap, fine aggregate and gabion stones shall be approved on the basis of it satisfying the following criteria:
1.      Stone Filling and Riprap:
    - a.      Freeze-Thaw Test: A maximum 10 percent loss, by weight, after 25 cycles of freezing and thawing. Test shall be performed in accordance with NYSDOT Materials Bureau, Materials Method 29, Test Method No. 703-08 P,G.
    - b.      Magnesium Sulfate Soundness Test: A maximum 10 percent loss by weight, after 10 cycles of the magnesium sulfate soundness test. Test shall be performed in accordance with ASTM C88 and NYSDOT Materials Bureau, Materials Method 29, Test Method No. 703-07 P,G.
  2.      Fine Aggregate:
    - a.      Magnesium Sulfate Soundness Test: A maximum 30 percent loss, by weight, after 5 cycles of the magnesium sulfate soundness test performed in accordance with ASTM C88 and NYSDOT Materials Bureau, Materials Method 29, Test Method No. 703-06 P,G.
    - b.      Organic Impurities Test performed in accordance with NYSDOT Materials Bureau, Materials Method 29, Test Method No. 703-03 P,G and AASHTO T-21 shall result in Organic Plate lighter than 3 and Gardner Color lighter than 11.

1.07      SUBMITTALS

- A.      Certified laboratory reports showing the following, as applicable:
1.      Stone filling or riprap meets the criteria of the freeze thaw test and the magnesium sulfate soundness test requirements specified herein in the subsection headed "Quality Assurance."
  2.      Bedding material conforms to gradation requirements.
  3.      Grout sand conforms to gradation requirements for grout for grouting riprap or grout for concrete block paving, as applicable.
  4.      Cushion sand for concrete block paving conforms to gradation requirements.
  5.      Gabion wire mesh, tie wire and stone meet the specified material requirements.

**GENERAL SPECIFICATION 02372 EMBANKMENT AND CHANNEL PROTECTION**

---

PART 2 PRODUCTS

2.01 MATERIALS

A. Stone Filling

1. The gradation of materials furnished for use as stone filling shall be as specified below, and will be accepted or rejected based on a visual examination of the material by the Engineer.



<b>STONE FILLING GRADATION REQUIREMENTS</b>			
<b>Stone Filling Item</b>	<b>See These Notes Below</b>	<b>Stone Size<sup>1</sup></b>	<b>Percent of Total by Weight</b>
Fine	2, 3, 4	Smaller than 8 inches Larger than 3 inches Smaller than No. 10 Sieve	90 - 100 50 - 100 0 - 10
Light	2, 3, 4	Lighter than 100 lbs. Larger than 6 inches Smaller than ½ inch	90 - 100 50 - 100 0 - 10
Medium	2, 4	Heavier than 100 lbs. Smaller than 4 inches	50 - 100 0 - 10
Heavy	2, 4, 5	Heavier than 600 lbs. Smaller than 6 inches	50 - 100 0 - 10
<b>NOTES:</b>			
<ol style="list-style-type: none"> <li>1. Stone sizes, other than weights, refer to the average of the maximum and minimum dimensions of a stone particle as estimated by the Engineer.</li> <li>2. Materials shall contain less than 20 percent of stones with a ratio of maximum to minimum dimension greater than three.</li> <li>3. Air-cooled blast furnace slag, cobbles or gravel having at least one fractured face per particle are acceptable substitutes for stone under these items, provided that soundness and gradation requirements are met.</li> <li>4. Materials shall contain a sufficient amount of stones smaller than the average stone size to fill the spaces between the larger stones.</li> <li>5. Heavier gradings of this item may be required on some projects, in which case the requirements will be stated on the Contract Drawings or in the Detailed Specifications.</li> </ol>			

2. The following table is provided to assist the Contractor and the Engineer in evaluating the gradation of materials considered for use as Stone Filling or Riprap.

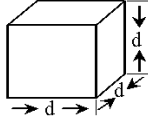
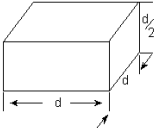
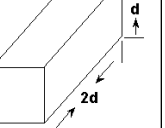

**GENERAL SPECIFICATION 02372 EMBANKMENT AND CHANNEL PROTECTION**

---

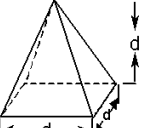
<b>CORRELATION OF STONE WEIGHTS AND DIMENSIONS</b>					
<b>SPECIFIC D Weights and Sizes</b>	<b>APPROXIMATE SHAPE</b>				
					
600 lbs	d = 18 ins.	d = 23 ins.	d = 15 ins.	d = 23 ins.	d = 27 ins.
300 lbs.	d = 15 ins.	d = 18 ins.	d = 12 ins.	d = 18 ins.	d = 21 ins.
150 lbs.	d = 12 ins.	d = 15 ins.	d = 9 ins.	d = 15 ins.	d = 17 ins.
100 lbs.	d = 10 ins.	D = 13 INS.	d = 8 ins.	d = 13 ins.	d = 15 ins.
d = 8 ins.	50 lbs.	25 lbs.	100 lbs.	25 lbs.	16 lbs.
d = 6 ins.	20 lbs.	10 lbs.	40 lbs.	10 lbs.	7 lbs.

**B. Dry Rip Rap.**

1. Dry riprap shall consist of stones shaped as nearly as practicable in the form of right rectangular prisms. At least 50 percent, by weight, of the stones shall weigh in excess of 300 pounds each, and the remainder of the stones shall weigh from 100 to 300 pounds each. One dimension of each of the stones furnished shall be at least equal to the thickness of the riprap as shown on the Contract Drawings.
2. The gradation of materials furnished for use as dry riprap will be accepted or rejected based on a visual examination of the material by the Engineer.

**C. Grouted Riprap.** The requirements for the stone used for grouted riprap shall be the same as specified for Dry Riprap. The grout shall consist of one part cement conforming to the requirements of ASTM C150 for Portland Cement Type II, and three parts of fine aggregate, conforming to the requirements for fine aggregate set forth in the subsection headed "Quality Assurance." When dry, the fine aggregate shall conform to the following gradation requirements:

**GENERAL SPECIFICATION 02372 EMBANKMENT AND CHANNEL PROTECTION**

---

SIEVE SIZE	Percent Passing by Weight	
	Minimum	Maximum
3/8 inch	100	--
No. 4	90	100
No. 8	75	100
No. 16	50	85
No. 30	25	60
NO. 50	10	30
No. 100	1	10
No. 200 (Wet)	0	3

- D. Bedding Material: Bedding material shall be composed of crushed stone, crushed air-cooled blast furnace slab, or gravel, free of soft, non-durable particles, organic material, and thin or elongated particles. Bedding material shall meet the following gradation requirements:

Sieve Designation	Percent by Weight Passing
4 in.	100
1 IN.	15 to 60
1/4 in.	0 to 25
No. 40	0 to 10

- E. Concrete Block Paving

- The concrete blocks shall be designed to have a compressive strength of 2,500 psi, and shall have the following minimum dimensions:

LENGTH:	THICKNESS:	Width:
16 to 20 inches	6 inches (solid)	8 inches

**GENERAL SPECIFICATION 02372 EMBANKMENT AND CHANNEL PROTECTION**

---

2. The standard dimensions of the block shall be the specified nominal dimensions minus 3/8 of an inch. The maximum permissible variation in dimensions of individual units from standard dimensions shall be no more than 1/8 inch. The size of block used shall be consistent throughout any continuously paved area, and only one nominal length shall be used in any contract. All units shall be sound and free from cracks or other defects that would interfere with the proper placing of the blocks or impair the strength, permanence and appearance of the construction.

3. Sampling and Testing

a. Sampling: Samples of the block will be selected by the Engineer from production lot quantities in accordance with the following:

LOT SIZE (NUMBER OF UNITS)	NUMBER OF SAMPLES
0 - 10,000	6
10,001 - 99,999	12
100,000 - 150,000	18
For each additional 50,000 or fraction thereof	6 additional samples

b. In no case will less than 6 blocks be selected as samples. Additional specimens may be required at the discretion of the Engineer. Samples may be taken at the manufacturing plant or at the job site, at the option of the Engineer.

c. Testing

1) Compressive strength tests of the block will be performed in accordance with the requirements of the Detailed Specifications. The minimum average compressive strength of concrete paving block samples shall be 2500 pounds per square inch. This strength shall be determined on full size block samples, by load application in a direction parallel to the slope upon which the block is to be placed. The compressive strength of any individual unit shall be not less than 2000 pounds per square inch.

**GENERAL SPECIFICATION 02372 EMBANKMENT AND CHANNEL PROTECTION**

---

- 2) The maximum average absorption of concrete paving block samples representing any lot shall not exceed 10 percent by weight. The absorption of any individual unit shall not exceed 12 percent by weight.
- 3) All test procedures shall be in accordance with ASTM C140.

**F. Cushion Sand**

1. Cushion sand for concrete block paving shall consist of clean, hard, durable, uncoated particles, free from lumps of clay and all deleterious substances. When dry, the cushion sand shall meet the following gradation requirements:

Sieve Size	Percent by Weight Passing
1/4 in.	100
No. 50	0 - 35
No. 100	0 - 10

2. The sand will not be approved for cushion sand if it contains more than 10 percent by volume of loam or silt. The cushion sand will be accepted on the basis of gradation tests and visual inspection at the point of use.
3. Grout, where used, shall consist of one part cement conforming to the requirements of ASTM C150 for Portland Cement Type II, and two parts fine aggregate, conforming to the requirements for fine aggregate set forth in the subsection headed "Quality Assurance." When dry, the fine aggregate shall conform to the following gradation requirements:

SIEVE SIZE	Percent by Weight Passing
No. 4	100
No. 8	95 - 100
No. 50	10 - 40
No. 100	0 - 15

4. As an alternative, the fine aggregate may be the same as that specified above for grouting riprap.

**GENERAL SPECIFICATION 02372 EMBANKMENT AND CHANNEL  
PROTECTION**

---

- G. Gabions. Gabions shall be constructed with galvanized wire or galvanized wire with coating of polyvinyl chloride (PVC) as shown on the Contract Drawings or specified in the Detailed Specifications. The wire mesh, tie wire, basket construction, and stone fill shall meet the material requirements set forth in Section 712-15, Gabions, of the NYSDOT Standard Specifications. Test reports on the wire and stone shall be conducted and certified by a testing facility approved by the City.

**PART 3 EXECUTION**

**3.01 INSTALLATION**

- A. General. The ground surface on which bank or channel protection is to be placed shall be free of brush, trees, stumps, and other objectionable material and shall be dressed to a smooth surface in accordance with General Specification 02230 – Site Clearing. All soft or spongy material shall be removed to the depth shown on the Contract Drawings or as directed by the Engineer and replaced with approved material. Excavation shall be in conformance with General Specification 02316 - Excavation. Filled areas shall be compacted in accordance with applicable provisions of General Specification 02317 - Backfilling. Dust, soil erosion and sedimentation control measures shall be performed in accordance with General Specification 02371 – Dust, Soil Erosion and Sedimentation Control. Protection for structure foundations shall be provided as early as the foundation construction permits. The type of protection shall be placed as shown on the Contract Drawings or called for by the Detailed Specifications.
- B. Stone Filling
  - 1. Stone filling shall be placed in a manner that will produce a reasonable well-graded mass of stone with smaller stone fragments filling the space between the larger ones, so as to result in the minimum practicable percentage of voids. The final section of stone filling shall be in conformance with the lines, grades and thicknesses shown on the Contract Drawings. Stone filling used for bank or channel protection shall be placed to its full course thickness in one operation, unless otherwise directed by the Engineer or specified in the Detailed Specifications, and in such a manner that the underlying material will not be displaced or worked into the layer of stone filling. Placement of stone upon finished bedding material, when used, shall be carefully controlled to avoid disruption and damage to the layer of bedding material. The stone shall be so placed and distributed that there will be no pockets of uniform size material.
  - 2. The desired distribution of the various sizes of stone throughout the mass shall be obtained by selective loading of the material at the quarry or other source; by controlled dumping of successive loads during final

## GENERAL SPECIFICATION 02372 EMBANKMENT AND CHANNEL PROTECTION

---

placing; or by other methods of placement which will produce the specified results. Rearranging of individual stones by mechanical equipment or by hand shall be done to the extent necessary to secure the specified results. When stone filling is dumped under water, methods shall be used that will minimize segregation.

- C. **Dry Riprap.** The stones shall be placed so that the dimension approximately equal to the layer thickness is perpendicular to the slope surface and that the weight of the stone is carried by the underlying material and not by the adjacent stones. On slopes, the largest stones shall be placed at the bottom of the slope. The dry riprap shall be properly aligned and placed so as to minimize void spaces between adjacent stones. The spaces between the stones shall be filled with spalls of suitable size.
- D. **Grouted Riprap**
  - 1. The procedure of placing the stones shall be the same as described in Paragraph 3.01C for Dry Riprap, except that the space between the stones shall be filled with grout rather than spalls. Material upon which the grouted riprap is laid shall not be allowed to occupy the space between the stones.
  - 2. When the stones are in place, the spaces between them shall be completely filled with grout and the surface of the stones cleaned to remove accumulations of grout. Riprap shall not be grouted in freezing weather. The grouted riprap shall be kept moist for seven days after grouting. A suitable curing compound may be employed, if approved by the Engineer.
  - 3. The Engineer may direct that occasional spaces be left ungrouted for relief of hydrostatic pressure. The ungrouted spaces shall be chinked with spalls of suitable size.
- E. **Bedding Material.** When called for on the Contract Drawings, specified in the Detailed Specifications, or directed by the Engineer, stone filling and dry riprap shall be placed on bedding material. The bedding material shall be placed on the prepared area to the full specified thickness of each layer in one operation, using methods which will not cause segregation of particles sizes. Contamination of bedding material by natural soils or other materials shall be prevented at all times. Bedding material that becomes contaminated shall be removed and replaced with uncontaminated bedding material at no expense to the City.
- F. **Concrete Block Paving**
  - 1. Blocks shall be laid on a 3-inch bed of cushion sand in running bond with the long dimension transverse to the slope and all joints tight.

**GENERAL SPECIFICATION 02372 EMBANKMENT AND CHANNEL  
PROTECTION**

---

Blocks shall be thoroughly rammed in place to provide a uniformly even surface and solid bedding under each block.

2. In the areas where grouting is called for, the concrete block shall be laid in running bond with the length parallel to the slope and with 1/4" joints. Following the laying of blocks, in the area to be grouted, sufficient sand of the same gradation as that used in the grout shall be spread over the surface and swept into the joints to fill the joints to four inches from the surface. The block shall be wetted to the satisfaction of the Engineer before any grout is placed. The joints shall be filled with grout from the bottom flush with the top of the block.
3. After grouting has been completed and the grout has sufficiently hardened, the blocks shall be wetted, covered and cured with curing covers for the first seven days after grouting. Grout shall not be poured during freezing weather.

**G. Gabions**

1. Each gabion unit shall be assembled by binding together all vertical edges with wire ties on approximately six-inch spacing or by a continuous piece of connecting wire stitched around the vertical edges with a coil about every four inches. Empty gabion units shall be set to line and grade as shown on the Contract Drawings. For structural integrity, wire ties or connecting wire shall be used to join the gabions together along the perimeter of all contact surfaces according to the manufacturer's instructions. Internal tie wires shall be uniformly spaced and securely fastened in each outside cell of the structure in accordance with the manufacturer's instructions or where ordered by the Engineer. When gabions are being placed as slope protection, the cross-connecting wire may be deleted if ordered by the Engineer.
2. A standard fence stretcher, chain fall, or iron rod may be used to stretch the wire baskets and hold alignment.
3. The gabions shall be filled with stone carefully placed by hand or machine to assure alignment and avoid bulges with a minimum of voids. After a gabion has been filled, the lid shall be bent over until it meets the side and edges. The lid shall then be secured to the sides, ends and diaphragms with the wire ties or connective wire in the same manner as described above for assembling.

END OF SECTION

**GENERAL SPECIFICATION 02372 EMBANKMENT AND CHANNEL  
PROTECTION**

---

NO TEXT ON THIS PAGE



**GENERAL SPECIFICATION 02461 STEEL SHEET PILING**

---

**SECTION 02461  
Steel Sheet Piling**

**PART 1        GENERAL**

**1.01        SECTION INCLUDES**

- A.    The Contractor shall furnish all labor, equipment and material required to handle, store and install all steel sheet piling and bracing systems as shown on the Contract Drawings, specified in the Detailed Specifications and as specified herein.
- B.    Steel sheet piling and all necessary structural shapes, bracing, bolts, washers, nuts, connections and miscellaneous appurtenances shall be of the form, weights, shapes and lengths as shown on the Contract Drawings and specified in the Detailed Specifications.
- C.    An index of the Articles in this Section is presented hereinafter for the convenience of the Contractor.

<u>Article</u>	<u>Title</u>	<u>Page</u>
		02461-
PART 1	GENERAL .....	1
1.01	Section Includes .....	1
1.02	Measurement And Payment .....	2
1.03	Related Sections .....	2
1.04	References .....	2
1.05	Submittals .....	3
1.06	Schedule Of Procedures And Operations .....	4
1.07	Qualifications .....	4
1.08	Seismic Monitoring .....	4
1.09	Examination Of The Site .....	5
1.10	Delivery, Storage And Handling .....	5
1.11	Job Conditions .....	5
PART 2	PRODUCTS .....	6
2.01	Materials .....	6
2.02	Welding .....	7
PART 3	EXECUTION .....	7
3.01	Fabrication .....	7
3.02	Driving .....	8
3.03	Pile Hammer .....	8
3.04	Excavation .....	8
3.05	Jetting .....	9
3.06	Obstructions .....	9
3.07	Tolerance .....	9
3.08	Sheet Piling Cutoff .....	9

## GENERAL SPECIFICATION 02461 - STEEL SHEET PILING

---

3.09	Survey Work .....	9
3.10	Damaged Sheet Piling.....	10
3.11	Painting .....	10
3.12	Inspection.....	10

### 1.02 MEASUREMENT AND PAYMENT

#### A. Measurement:

1. The quantity, in pounds, to be measured for payment shall be in accordance with the latest Code of Standard Practice for Steel Buildings and Bridges of the AISC.
2. Only the weight of steel sheet piling below the cutoff lines indicated on the Contract Drawings or specified in the Detailed Specifications shall be measured for payment.
3. Cutoffs, wales, anchors, ties, struts and bracing and removal of material will not be included in measurement, but shall be considered as included in the price paid for the work of this section.

#### B. Payment:

1. No payment will be made for steel sheet piling which the Contractor uses for his own purposes or for steel sheet piling required to complete the work under another item of the Contract, except where such piling is left in place on written order of the Engineer.
2. Payment for steel sheet piling work will be as provided in the Detailed Specifications and will be made at the unit prices bid for weight of sheet piling in pound The unit price bid shall include the cost of furnishing all labor, materials, equipment and incidentals necessary to complete the work.

### 1.03 RELATED SECTIONS

- |    |                             |   |                    |
|----|-----------------------------|---|--------------------|
| A. | General Specification 02316 | - | Excavation         |
| B. | General Specification 05081 | - | Galvanizing        |
| C. | General Specification 05120 | - | Structural Steel   |
| D. | General Specification 05501 | - | Metal Fabrications |
| E. | General Specification 09900 | - | Painting           |

### 1.04 REFERENCES

- |    |          |   |   |
|----|----------|---|---|
| A. | ASTM A6  | - | General Requirements for Rolled Structural Steel Bars, Plates, Shapes and Sheet Piling. |
| B. | ASTM A36 | - | Carbon Structural Steel.  |

## GENERAL SPECIFICATION 02461 STEEL SHEET PILING

---

- C. ASTM A307 - Carbon Steel Bolts and Studs, 60,000 psi Tensile Strength.
  - D. ASTM A325 - Structural Bolts, Steel, Heat Treated, 120/105 ksi Minimum Tensile Strength.
  - E. ASTM A328 - Steel Sheet Piling.
  - F. ASTM A370 - Test Methods and Definitions for Mechanical Testing of Steel Products.
  - G. ASTM A572 - High Strength Low-Alloy Columbium-Vanadium Structural Steel.
  - H. ASTM A673 - Sampling Procedure for Impact Testing of Structural Steel.
  - I. ANSI/AWS D1.1 - Structural Welding Code.
  - J. ANSI/AWS QC1 - Qualification and Certification of Welding Inspectors.
  - K. New York City Building Code (NYBC).
  - L. New York City Board of Standards and Appeals (BS&A).
  - M. American Institute of Steel Construction (AISC).
  - N. Specifications for Structural Joints Using ASTM A325 or A490 Bolts (AISC).
  - O. Code of Standard Practice for Steel Buildings and Bridges (AISC).
- 1.05 SUBMITTALS
- A. The Contractor shall submit Shop Drawings and material specifications for the approval of the Engineer. Submittals shall include, but not be limited to:
    - 1. Details of pile driving equipment
    - 2. Certification that materials meet ASTM requirements
    - 3. Detail drawings of steel sheet piling, shoring and bracing
    - 4. Details of all connections and brackets, including corner details
    - 5. Schedule of procedures and operations
    - 6. Sample of driving record forms
    - 7. Sheet piling installation sequence
    - 8. Sheet piling location survey (project record documents).
  - B. After locations of utilities and other underground obstructions have been confirmed, provide drawings showing the actual locations of existing utilities, structures or other interferences in relation to the proposed locations of steel sheet piling and bracing.

- C. Any variations proposed by the Contractor between the Contract Drawings and requirements in this Section shall be submitted for review and approval to the Engineer and shall also require approval by the City. For all proposed variations or alternatives, the Contractor shall submit engineering calculations and design assumptions for determinations of loads and stresses acting in the wall and lateral supports during installation, as well as final conditions. The redesign shall take into account the excavation procedures, dewatering operations, surcharge loading, soil properties, material stresses, temperatures, permanent construction, stages of work and all other conditions which could affect the excavation support system. These calculations must be prepared and stamped by a Professional Engineer licensed in the State of New York.
- D. After installation, prepare dimensioned as-built CAD drawings of the complete support system and of the portion of the system left in place.

1.06 SCHEDULE OF PROCEDURES AND OPERATIONS

- A. Before commencing any steel sheet pile installation, the Contractor shall submit to the Engineer for approval, a schedule of the procedures he intends to use.
- B. The schedule shall show in detail his proposed method, sequence and timing of all steel sheet piling driving operations, catalog data and manufacturer's specification for all hammers and anvils to be used, method of lifting, handling, driving and cutting off of steel sheet piles.

1.07 QUALIFICATIONS

- A. The work shall be performed by a General Contractor or a specialty Subcontractor specializing in the specified steel sheet piling system and having experience installing the specified system under similar conditions.

1.08 SEISMIC MONITORING

- A. When driving steel sheet piling, the Contractor shall provide the monitoring stations at locations shown on the Contract Drawings or specified in the Detailed Specifications.
- B. All pile driving, removal of piling, demolition and related sheet piling activities shall be performed in a manner so that the following criteria shall not be exceeded; peak resultant particle velocity of one-inch per second at location of sensitive instruments and two-inches per second at concrete structures.
- C. The Engineer reserves the right to change the locations of the monitoring stations, as required during construction. The Contractor shall engage the services of an approved geotechnical consultant (who shall be a registered Professional Engineer in the State of New York) experienced in the monitoring of vibrations, to install, maintain and monitor an approved seismic monitoring system.

## GENERAL SPECIFICATION 02461 STEEL SHEET PILING

---

- D. Particle velocity shall be measured by using seismographs capable of measuring peak component particle velocities in the range of 0.2 to 0.4 in/sec. All pile driving vibrations shall be monitored for the duration of pile driving unless otherwise ordered to be discontinued by the Engineer. In the event that the monitoring is ordered to be discontinued a suitable credit shall be due the City.
  - E. All vibration monitoring of specified locations shall be implemented in such a manner that peak component particle velocity can be determined shortly after instances where the vibrations exceed the above criteria. Both the Contractor and the Engineer shall be notified within 30 minutes after any such occurrence and the actual peak particle velocity identified.
  - F. Permanent vibrations monitoring records of each day's work shall be maintained until the completion of the work or until such time when monitoring is ordered to be discontinued. Such records shall be turned over to the Engineer upon completion of all seismic monitoring work. Monthly reports shall include a tabulation of all instances of vibration levels in excess of the seismic criteria noted above.
  - G. The cost of the work specified under this section shall be included in the lump sum price bid for the Contract unless otherwise specified in the Detailed Specifications.
- 1.09 EXAMINATION OF THE SITE
- A. Prior to starting steel sheet piling driving operations, the Contractor, the City and the Engineer shall make a joint inspection of the accessible existing structures, pavement and improvements adjacent to the pile driving site to examine and document their present condition.
  - B. Photographs and measurements shall be taken by the Contractor to record any conditions that may become the subject of possible damage claims.
  - C. The Contractor shall prepare a report of such conditions, verified by the photographs, and signed by the personnel of the Contractor, the City and the Engineer participating in the investigation.
- 1.10 DELIVERY, STORAGE AND HANDLING
- A. Storage of sheet piling and other excavation support materials shall be such that sagging which would produce permanent deformation shall be prevented. Concentrated loads which occur during stacking or lifting shall be kept below the level which would produce permanent deformation of the material.
- 1.11 JOB CONDITIONS
- A. The excavation support system must retain the adjacent soil, water, structures, utilities, streets and other features and must protect them from damage due to settlement, lateral movements, loss-of-ground or any other causes related to this construction. The Contractor shall be responsible for taking all precaution

## GENERAL SPECIFICATION 02461 - STEEL SHEET PILING

necessary to prevent such damage. An important function of the sheeting is to act as a ground water cutoff so as to prevent disturbance of subgrade at bearing level due to groundwater inflow into the excavation.

- B. The Contractor shall be fully responsible for installing and maintaining the rakers, and corner bracing as necessary to minimize movements of the wall during all stages of construction.
- C. Expose active utilities by hand, where they lie within work areas. All existing utilities affected by construction shall be temporarily supported and protected from harm.
- D. If existing utilities interfere with the method of excavation support shown on the Contract Drawings, relocate the utilities as approved by the Engineer.
- E. Use continuous members for the excavation support system unless otherwise approved by the Engineer.

### PART 2 PRODUCTS

#### 2.01 MATERIALS

- A. Steel sheet piling shall conform to the requirements of ASTM A328 or ASTM A572. Sheet piles shall be new and shall consist of rolled sections of the continuous interlocking type of the section, length, weight and ASTM shown on the Contract Drawings or specified in the Detailed Specifications.
  - 1. Sheet piling utilized for temporary construction shall conform to ASTM A328.
  - 2. Sheet piling installed as permanent construction shall conform to ASTM A572.
    - a. Each heat shall meet the Charpy V-notch impact test requirements of ASTM A370. Samples shall be machined in a set of three and tested at the following minimum requirements for temperature and test value:

Temperature	Test Value
30°F	25 ft-lb
0°F	15 ft-lb

- b. When using subsize samples, that is thickness of less than one-half inch as specified in ASTM A673, the following minimum requirements shall be met:

## GENERAL SPECIFICATION 02461 STEEL SHEET PILING

---

Temperature	Test Value
30EF	19 ft-lb
0EF	11 ft-lb

- c. In the event that the average ft-lbs of the three samples does not meet the above requirements when tested at both temperatures, all the material manufactured from that sheet shall be rejected.
- B. All structural shapes, plates and similar members shall conform to the requirements of ASTM A6 and A36, and General Specifications 05120 – Structural Steel and 05501 – Metal Fabrications.
- C. Bolts, nuts and washers shall conform to the requirements of ASTM A325 or A307. All hardware for permanent construction shall be galvanized in accordance with General Specification 05081 - Galvanizing.
- D. Minimum web and flange thickness of the steel sheet piling shall be 3/8 inch unless otherwise shown on the Contract Drawings or specified in the Detailed Specifications.
- E. Opening of socket at interlock shall be checked with manufacturer supplied tolerance gages.

### 2.02 WELDING

- A. Welding shall be performed in accordance with the requirements of:
  - 1. ANSI/AWS D1.1 Structural Welding Code.
  - 2. Relevant sections of the NYBC.
  - 3. Latest rules of the BS&A.
- B. All shop and field welding shall be performed by certificated welders under the immediate supervision of a representative of a standard testing agency or an inspection agency reporting directly to and under the control of the Department of Environmental Protection. The Contractor shall submit the name of such agency to the Commissioner for approval before starting work. The costs of all welding inspections shall be borne by the Contractor.

## PART 3 EXECUTION

### 3.01 FABRICATION

- A. Steel sheet piling shall be new and so fabricated that when driven in place, it will form a continuously interlocked wall to the extent shown on the Contract Drawings. Steel sheet piles with bends or springs, or with damaged interlocks shall not be used.

- B. Steel sheet piling shall be full length, no splices will be permitted.
- C. Walers and braces may be prefabricated or fabricated in place. All welding shall conform to the requirements of Article 2.02, Welding.

3.02 DRIVING

- A. Steel sheet piling shall be carefully positioned at the locations shown on the Contract Drawings and driven in a plumb position, to the minimum tip elevations shown on the Contract Drawings or specified in the Detailed Specifications.
- B. Sheet piling shall penetrate to approved depth in firm subsurface material and each sheet pile shall interlock with the adjacent sheet pile so as to form a single continuous wall. Piling shall be driven in vertical increments limited in such a manner so that driving proceeds without erratic advance of individual sheets.
- C. Sheet piles shall be driven in such a manner as to insure continuous interlocking throughout the length of the sheet piles. Sheet piles shall be driven in pairs with ball end leading.
- D. Steel sheet piling shall be framed with and connected to other structural members and shapes as shown on the Contract Drawings or specified in the Detailed Specifications.
- E. In the event the sheet piling cannot be driven to the minimum tip elevation, the Contractor shall immediately notify the Engineer for corrective measures.

3.03 PILE HAMMER

- A. Pile hammers shall have a sufficient reserve capacity for driving the sheet piles to the design requirements, including any contingencies occurring during driving. The minimum hammer energy and maximum hammer energy in foot-pounds per blow shall be as shown on the Contract Drawings or specified in the Detailed Specifications, and in accordance with NYBC.
- B. The lower end of the hammer shall be fitted with an anvil base that is built to fit the top of the steel sheet piling and to hold the sheet piling under the center of the hammer during driving.

3.04 EXCAVATION

- A. Excavation shall conform to General Specification 02316 – Excavation and shall not be carried in advance of or below the bottom of the steel sheet piling.
- B. Excavation within the sheet piling shall not be performed until the bracing system, if required by the Contract Drawings or Detailed Specifications, has been installed at the stage and in the sequence as approved by the Engineer.



## GENERAL SPECIFICATION 02461 STEEL SHEET PILING

---

### 3.05 JETTING

- A. Steel sheet piling shall be jetted only when written permission is given by the Engineer. Sufficient jets and adequate water pressure shall be used to erode the material adjacent to the pile without impairing the penetration of steel sheet piling already in place.
- B. Before the desired penetration is reached, the jets shall be withdrawn and the steel sheet piling shall be driven with the hammer alone to obtain the required penetration in the subsurface material.

### 3.06 OBSTRUCTIONS

- A. Any obstructions encountered in driving the steel sheet piling shall be removed or otherwise disposed of by the Contractor so as to permit the proper installation of the sheet piling.
- B. After the removal of the obstructions, the steel sheet piling shall be redriven to the required penetration. It is essential that the Contractor familiarize himself with the site conditions and the subsurface conditions at the site so as to be prepared for removal of obstructions.
- C. The Contractor shall have on hand suitable equipment for removing obstructions, and shall employ this equipment, in a manner satisfactory to the Engineer.

### 3.07 TOLERANCE

- A. Steel sheet piling shall be driven plumb to the lines, grades and depths shown on the Contract Drawings or specified in the Detailed Specifications with secure interlocking for the entire length of the sheet piling.
- B. Driving shall be done with fixed leads to hold the sheet piling firmly in position and alignment and in axial alignment with the hammer.

### 3.08 SHEET PILING CUTOFF

- A. The Contractor shall cutoff sheet piling left in place to the grades established on the Contract Drawings or specified in the Detailed Specifications.
- B. Cutoffs are the property of the Contractor and shall be disposed of off-site.

### 3.09 SURVEY WORK

- A. The Contractor shall engage the services of a licensed surveyor, approved by the Commissioner, for the performance of the survey work.
- B. Before starting work, the Contractor shall survey adjacent structures and improvements, establishing exact elevations at fixed points to act as benchmarks. He shall clearly identify benchmarks and record existing elevations. Datum level used to establish benchmark elevations shall be located

at a sufficient distance so as not to be affected by movement resulting from excavation or construction operations.

- C. During excavation, the Contractor shall resurvey benchmarks as required by the Detailed Specifications. The Contractor shall maintain an accurate log of surveyed elevations for comparison with original elevations, and shall promptly notify the Engineer if changes occur or if cracks, sags or other damage is evident.
- D. The installed location of the sheet piling shall be established by survey and shown on drawings prepared for this purpose as project record documents. Upon completion of the sheet piling installation, the Contractor shall submit to the City, mylars of drawings showing installed location of the sheet piling as related to column lines, center of footings or other reference points and lines, the cutoff elevation, and length below cutoff for each pile. Mylars shall be the same size as the Contract Drawings.

### 3.10 DAMAGED SHEET PILING

- A. Any sheet piling, which at any time becomes damaged, displaced, separated from adjacent sheets or otherwise injured, shall be withdrawn and replaced with new sheet piling at the expense of the Contractor.
- B. All damaged sheet piling shall be removed from the site by the Contractor.

### 3.11 PAINTING

- A. Structural steel braces and supports attached to the steel sheet piling and exposed in the finished work and indicated to remain shall be thoroughly cleaned, prepared for painting and painted in accordance with the requirements of General Specification 09900 - Painting.

### 3.12 INSPECTION

- A. All inspections will be performed by the Engineer designated for controlled inspection.
- B. The driving of each sheet piling section is a mandatory hold point for which prior notification of the Engineer is required, and driving of each piling section shall be performed in the presence of the Engineer. Driving records will be kept by the Engineer.
- C. The Contractor shall cooperate with the Engineer in determining the resistance to penetration and shall mark each piling section at one foot intervals before driving or as required by the Engineer.

END OF SECTION

**GENERAL SPECIFICATION 02501 REINFORCED CONCRETE SEWER PIPE**

---

**SECTION 02501  
Reinforced Concrete Sewer Pipe**

PART 1 GENERAL

1.01 SECTION INCLUDES

- A. The Contractor shall furnish and install reinforced concrete sewer pipe, fittings and specials.
- B. The following index of this Section is included for convenience:

<u>Article</u>	<u>Title</u>	<u>Page</u>
		02501-
PART 1	GENERAL.....	1
1.01	Section Includes.....	1
1.02	Related Sections.....	1
1.03	Payment.....	1
1.04	References.....	2
1.05	Design Requirements.....	2
1.06	Submittals.....	3
1.07	Quality Assurance.....	4
1.08	Delivery, Storage And Handling.....	4
PART 2	PRODUCTS.....	4
2.01	Reinforced Concrete Pipe.....	4
2.02	Reinforced Concrete Fittings And Specials.....	6
2.03	Joints.....	6
2.04	Curing.....	7
2.05	Shop Testing.....	8
PART 3	EXECUTION.....	10
3.01	Installation.....	10
3.02	Leakage Tests.....	11
3.03	Schedules.....	11

1.02 RELATED SECTIONS

- A. General Specification 02505 - Leakage Tests
- B. General Specification 03300 - Cast-in-Place Concrete
- C. General Specification 03410 - Precast Structural Concrete

1.03 PAYMENT

- A. Payment will be made as described in the Detailed Specifications.

## GENERAL SPECIFICATION 02501 REINFORCED CONCRETE SEWER PIPE

---

### 1.04 REFERENCES

- A. ASTM A283 - Low and Intermediate Tensile Strength Carbon Steel Plates
- B. ASTM A1011 - Steel, Sheet and Strip, Hot-Rolled, Carbon, Structural, High-Strength Low-Alloy, High-Strength Low-Alloy with Improved Formability, and Ultra-High Strength
- C. ASTM B127 - Nickel-Copper Alloy (UNS N04400) Plate, Sheet, and Strip
- D. ASTM C31 - Making and Curing Concrete Test Specimens in the Field
- E. ASTM C39 - Standard Test Method for Compressive Strength of Cylindrical Concrete Specimens
- F. ASTM C76 - Reinforced Concrete Culvert, Storm Drain and Sewer Pipe
- G. ASTM C361 - Reinforced Concrete Low-Head Pressure Pipe
- H. ASTM C443 - Joints for Concrete Pipe and Manholes, Using Rubber Gaskets
- I. ASTM C497 - Standard Test Methods for Concrete Pipe, Manhole Sections, or Tile
- J. AWWA C302 - Reinforced Concrete Pressure Pipe, Noncylinder Type

### 1.05 DESIGN REQUIREMENTS

- A. Concrete shall conform to General Specifications 03300 – Cast-in-Place Concrete and 03410 – Precast Structural Concrete, and when tested at the end of 28 days shall have the following minimum compressive strengths:
  - 1. PRECAST PIPE - 4,000; 5,000; 6,000 psi
  - 2. MONOLITHIC SEWERS - 3,500 psi
  - 3. CRADLES AND ENCASEMENT - 3,500 psi
- B. Design: Provide the classes of reinforced concrete sewer pipe as shown or specified. Conform pipe designs to the following requirements.
  - 1. Use diameter, wall thickness, compressive strength of concrete and area of circumferential reinforcement as prescribed for Classes I to IV in Tables 1 to 5 in ASTM C76, except do not use Wall A thickness, elliptical reinforcing cages or quadrant reinforcing mats. Do not substitute modified designs for designs shown in the tables.
  - 2. Provide special designs only for pipe with diameters and loads beyond those shown in Tables 1 to 5, pipe diameters that do not have steel reinforcement areas shown in the tables and pipe subject to thrust forces encountered in

## **GENERAL SPECIFICATION 02501 REINFORCED CONCRETE SEWER PIPE**

---

jacking operations. Conform special designs with the requirements of Section 7.2.2 of ASTM C 76, except do not use Wall A thickness, elliptical reinforcing cages or quadrant reinforcing mats without prior approval. Retain a Registered Professional Engineer, licensed in the State of New York, to prepare, sign and seal all special designs for pipe.

- C. Precast reinforced concrete pipe shall conform to the requirements of ASTM C76 for circular steel reinforcement and the three-edge bearing strength test requirements for the load to produce the 0.01 inch crack and for the ultimate load. When the strength test requirements specified in the Detailed Specifications are greater than the strength test requirements of ASTM C76, the thickness of the pipe wall may be increased, the area of circular steel reinforcement increased, or a combination of these, all as approved by the Engineer.
- D. Joints:
  - 1. Provide joints for pipe, fittings and specials in gravity sewer and drain lines meeting the requirements of ASTM C443 and this Specification.
  - 2. Provide joints for pipe, fittings and specials in concrete pressure lines with test pressures of 125 ft. or less meeting the requirements of ASTM C361 and these specifications.
  - 3. Provide joints for pipe, fittings and specials in concrete pressure lines with test pressures over 125 ft. as described in the Detailed Specifications.

### 1.06 SUBMITTALS

- A. The Contractor shall submit Shop Drawings and material specifications for the approval of the Engineer. Submittals shall include, but not be limited to:
  - 1. All diameters and classes of reinforced concrete pipe, fittings and specials and for concrete sills showing dimensions, strength and materials specifications and standards, joint details and reinforcement position
  - 2. Area of all cages of reinforcing steel
  - 3. A minimum clearance of one inch for each cage of circumferential reinforcing steel shown
  - 4. Angle of the joint
  - 5. Length and thickness of bell and spigot
  - 6. Length and thickness of joint
  - 7. Manufacturer, size and type of gasket
  - 8. Manufacturer's recommendations for gap dimension and tolerance for a properly installed pipe joint
  - 9. Signature and title of authorized representative of the manufacturer

## **GENERAL SPECIFICATION 02501 REINFORCED CONCRETE SEWER PIPE**

---

10. All requirements of the latest ASTM Specifications for Precast Reinforced Concrete Pipe as called for in these specifications will be complied with in the manufacture of the pipe

B. Joint Compliance: Submit notarized affidavit of joint compliance with ASTM C443 and these specifications for each pipe size. The statement shall include date of test.

C. Quality Control: Submit certified results of all shop tests for approval.

### 1.07 QUALITY ASSURANCE

A. General: Provide concrete pipe, fittings and specials that are precast or machine made and are the product of a company that can demonstrate by tests and installation records satisfactory experience in manufacturing concrete pipe of the quality and type specified.

### 1.08 DELIVERY, STORAGE AND HANDLING

A. Do not ship pipe to the site of the work until the pipe test results are certified by the Engineer.

## PART 2 PRODUCTS

### 2.01 REINFORCED CONCRETE PIPE

A. Manufacture:

1. Do not use admixtures or blends in concrete without prior approval.
2. The manufacturer shall maintain a satisfactory manufacturing schedule and shall have adequate storage facilities so that the work will not be delayed.
3. Cast pipe in steel forms to the exact dimensions shown, specified or required. Unless otherwise shown or specified, the inner and outer rings of reinforcement shall be concentric. Provide chairs and spacers to insure and maintain the proper position of reinforcement steel with respect to the protective concrete covering. Pipes in which reinforcing steel is placed beyond the tolerances allowed by ASTM C76 will be rejected. Use metal spacers at the top between the inner and outer forms to maintain uniform wall thickness in casting pipe. Where reinforcement mesh is used in the pipe, curve such reinforcement to shape on rolls having grooves for the longitudinal wires. In casting pipe, do not cut wires for form spacers or for other purposes. Provide continuous internal vibration of concrete during the pouring operation.
4. The Contractor will be responsible for meeting all requirements for the manufacture of precast pipe and checking at regular intervals all of such requirements.

## **GENERAL SPECIFICATION 02501 REINFORCED CONCRETE SEWER PIPE**

---

- B. Lengths: Manufacture all reinforced concrete pipe in lengths of not more than 16 feet and not less than 8 feet as follows, except where shorter lengths are required and approved for pipeline curves or at junctions with structures.
1. Furnish subaqueous pressure pipe in lengths of not less than 16 feet for pipe up to and including 84 inches in diameter. Pipe larger than 84 inches in diameter may be of lengths less than 16 feet, decreased on a sliding scale in accordance with the manufacturer's recommendations and as approved by the Engineer.
  2. Furnish pressure pipe to be installed inland in lengths not less than 12 feet, except that pipe to be laid in sheeted trench shall be furnished in lengths not less than 8 feet.
- C. Labeling: Immediately after the stripping of forms, all pipe manufactured for the Department of Environmental Protection as required under this contract shall be marked and identified with the following data: DEP, contract name and number, class and diameter of pipe, number of pipe, date of manufacture and the name of the manufacturer. The numbering of the pipe shall be consecutive for each diameter of pipe. Brass lettering templates designed to stencil this information on each pipe shall be provided by the pipe manufacturer. The aforementioned data shall be stenciled on the inside and outside of each length of pipe with waterproof ink or paint. Any pipe arriving at the location of the work without this information stenciled thereon will be rejected. At the end of each day of casting of the pipe, the manufacturer shall forward to the Engineer three copies of a report giving the diameters and the respective numbers of pipe cast that day.
- D. Monolithic Sewers:
1. Forms for monolithic concrete sewers shall be smooth, regular and true to shape. Forms which do not meet these requirements or which result in interior surfaces or thicknesses inferior to commercial precast concrete pipe shall not be used. Forms shall be thoroughly cleaned and approved by the Engineer before re-use. Sheeting shall not be used as exterior forms for monolithic concrete sewers.
  2. Concreting, unless otherwise approved by the Engineer, shall proceed in lengths of not less than 12 feet.
  3. Construction joints both longitudinal and transverse in monolithic concrete sewers shall have fabricated nickel-copper roofing sheet water stops conforming to the requirements of ASTM B127.

### **2.02 REINFORCED CONCRETE FITTINGS AND SPECIALS**

- A. General: Provide reinforced concrete fittings and specials where shown, specified or required, and manufactured in accordance with the applicable sections of the respective standard for the adjoining pipe. Provide joints the same as in the adjoining pipe. Provide the interior surface of bends of the same smoothness and

## **GENERAL SPECIFICATION 02501 REINFORCED CONCRETE SEWER PIPE**

---

diameter as the adjoining pipe. Provide the center line radius of curvature of bends to be equal, in dimension, to the inside diameter of the pipe.

- B. Strength: Design all reinforced concrete fittings and specials to have the same strength as the class of the adjoining pipe. Retain a Registered Professional Engineer, licensed in the State of New York to prepare, sign and seal all designs for fittings and specials.
- C. Standard fitting such as bends, tees, wyes and reducers shall be formed of steel, cut, shaped and welded to the proper form. Interior and exterior concrete or mortar shall be placed in approved manner.
- D. Special pieces and openings in standard pipe such as closures, wall fittings, adapters, manholes, air valve outlets, blow-offs and branches shall conform to details approved by the Engineer.

### 2.03 JOINTS

- A. General: Rubber gaskets shall be stored in as cool a location as practicable, preferably at 70 degrees F or less. In no case shall gaskets be exposed to the direct rays of the sun for a total of more than 24 hours.
- B. Gravity Sewer and Drain Lines:
  - 1. Manufacture all gravity sewer and drain pipe, fittings and specials with watertight joints using rubber gaskets in accordance with the requirements of ASTM C443. Provide a preformed groove in the tongue or spigot of sufficient depth to hold the gasket securely in place and produce the proper gasket compression. Reinforced concrete pipe joints shall be optional as to shape, except that no joint shall have a groove in which the wall thickness of the pipe is reduced to less than one-half, other than by a slight draw or taper, unless approved by the Engineer in writing.
  - 2. Manufacture the pipe with perfectly machined castings for forming the bells and spigots so that they will be true circles and when laid together the annular space for the rubber gasket will be perfectly uniform. The diameters of the bell and spigot surfaces, depended upon to compress the gasket, shall not vary from the theoretical diameters by more than 1/16 inch. The joint shall not project beyond the body of the pipe.
  - 3. Reinforce the bells of the pipe with a single cage of steel in which the circumferential members are the same gauge as those in the body of the pipe, but spaced on no more than 1 inch centers.
  - 4. The type and the manufacturer of the flexible rubber gaskets to be used shall be submitted for approval before pipe laying begins.
- C. Concrete Pressure Lines:



## **GENERAL SPECIFICATION 02501 REINFORCED CONCRETE SEWER PIPE**

---

1. Provide all concrete pressure pipe, fittings and specials with watertight joints using rubber gaskets in accordance with the requirements of ASTM C361 and this Specification.
2. Connect adjacent pipes by self-centering steel joint rings sealed with a continuous round rubber gasket. The joint shall be tight under normal conditions of service, and shall be sufficiently flexible to permit expansion and contraction as well as slight deflection due to normal earth settlement.
3. Specially shape the rings which form the joint so that they will join with a close, sliding fit. The joint surfaces shall be such that the rubber gasket will be confined on all sides.
4. Provide the spigot ring with an external groove accurately sized to receive the gasket. Special section steel for spigot rings shall conform to ASTM A283/A283M, Grade A or B.
5. Place the bell ring to permit gradual deformation of the gasket when the joint is assembled. The minimum thickness of bell rings shall be 3/16 inch. Bell rings for pipe sizes 42 inches and larger shall have a minimum thickness of 1/4 inch. Bell rings 1/4 inch and thicker shall conform to ASTM A283/A283M, Grade A or B. Bell rings less than 1/4 inch thick shall conform to ASTM A570/A570M, Grade A.
6. Precisely size each ring by expansion beyond the elastic limit of the steel and then gaging on an accurate template. Protect all exposed surfaces of both rings with a corrosion-resistant coating of zinc applied by an approved metalizing process after cleaning.
7. Provide a continuous rubber gasket with smooth surfaces free from imperfections. It shall be circular and shall fill the grooved recess between the assembled joint rings. Rubber compound used shall conform to the requirements of Section 4.4.10 of AWWA C302.

### 2.04 CURING

- A. Cure all pipe, fittings and specials by steam or membrane curing. Water curing is not permitted.

### 2.05 SHOP TESTING

- A. Test concrete sewer pipe in accordance with the applicable provisions of ASTM C497, as required by the ASTM Specification for the pipe and as specified herein.
- B. Test cylinders: Each day the Contractor shall prepare two test cylinders made from the concrete used for manufacturing the pipe under this contract.
  1. Make test cylinders in accordance with the requirements of ASTM C31 and cure and store them under identical conditions with the pipe. Test cylinders shall be properly marked for identification and dated.

## **GENERAL SPECIFICATION 02501 REINFORCED CONCRETE SEWER PIPE**

---

2. The Engineer will have the cylinders tested to determine whether the concrete complies with the strength requirements. Of each pair of test cylinders, one cylinder will be tested at 7 days, and the other test cylinder will be tested at 28 days. Test cylinders will be tested in accordance with ASTM C39 and the cost of such tests will be borne by the City.
- C. Test Pipe Sections:
1. When lengths of pipe are 8 feet or less, the Engineer will select one length from every fifty lengths of each diameter and class.
  2. When lengths of pipe are more than 8 feet, the Contractor shall provide a pipe test specimen four feet long for every 50 lengths of each diameter and class. Each test specimen shall be manufactured, marked for identification and shall meet the strength test requirements as specified for the pipe it represents. The manufacturing and marking of the pipe test specimen shall be witnessed by the Engineer.
  3. Where less than 50 lengths are required for any pipe diameter, one eight-foot length of pipe will be selected by the Engineer or one pipe test specimen shall be provided for testing purposes; however, the Engineer may waive this requirement at his discretion.
  4. Age of Pipe: Pipe selected or pipe tested specimens provided as specified for testing purposes shall be at least twenty-eight days old but shall not be over thirty days old at the time of testing.
    - a. Due to unforeseen conditions beyond the control of the Engineer and the manufacturer, special permission will be given in writing by the Engineer to delay a test beyond the thirty day aging period.
    - b. The three-edge load bearing strength at 0.01-inch crack and the ultimate load strength of pipe tested after twenty-eight days will be corrected to the twenty-eight day strength by deducting 1/2 of one percent of the recorded strength for each day beyond the twenty-eight day age.
    - c. The Contractor may request tests to be made on pipe which has aged at least fourteen days and not more than 28 days but the tests must meet the 28 day strength test requirement in order to be accepted by the Engineer for installation in the work.
- D. Basis of Acceptance: Conform the basis of acceptance for reinforced concrete pipe to Section 5.1.1 of ASTM C76 and this Specification.
1. The Engineer will reject all pipe of the lot which the tested length of pipe represents if the actual or corrected strength of the pipe tested fails to meet the three-edge load bearing strength test requirements. However, if the eight-foot length of pipe selected by the Engineer fails to meet the three-edge loading bearing strength test requirements, the Contractor may request

## GENERAL SPECIFICATION 02501 REINFORCED CONCRETE SEWER PIPE

---

that tests be made on two other eight-foot lengths of pipe representing that lot from which the original pipe tested was selected. The Engineer will select these two lengths of pipe. Should the tests on these two lengths of pipe prove satisfactory, the lot, represented by these lengths of pipe will be accepted. Should the tests on one or two of these lengths of pipe prove unsatisfactory, no further tests on any other lengths of pipe from this lot will be made, and all the pipe in this particular lot will be rejected.

2. The Engineer may accept precast pipe which meets the 0.01-inch crack strength test requirements but does not meet the ultimate load strength test requirements; however, the City will deduct 1/2 of one percent of the price bid per linear foot for that item which covers that particular pipe diameter and test strength requirements, for each one percent by which the ultimate load is below the required ultimate load. This deduction will be made on all pipe represented by the test specimen.
- E. Proof-of-Adequacy Tests for Special Designs: Prior to manufacturing production run pipe of special design, test one pipe of at least four feet in length of each diameter and class by the three-edge-bearing method to confirm that the pipe meets both the 0.01-inch crack and ultimate load requirements for which it is designed.
- F. Joint Adequacy Tests:
1. Prior to manufacturing production run pipe, fittings and specials, conduct all tests required by Sections 9 and 10 of ASTM C443 for each diameter of pipe.
  2. Give two weeks' notice in writing, before the day of testing, to both the Engineer and the approved laboratory, to witness the tests. The Department of Environmental Protection reserves the right to have an inspector or authorized representative present at the time of the tests.
  3. All manufacturers supplying reinforced concrete pipe to the Department of Environmental Protection shall, for each size of pipe and gasket combination submitted for approval, have on file with the Department a Certified Statement attested thereto by the City inspector or representative that the hydrostatic test on pipe and on rubber gasket was performed in accordance with the above-mentioned ASTM designation and passed.
- G. Location of Tests: The pipe selected or the pipe test specimen provided for test shall be delivered by the Contractor to an approved testing laboratory and removed by the Contractor after the test has been made. The Contractor may request that tests be made at the manufacturer's plant; however, the pipe manufacturer shall provide an approved and certified testing machine with a hydraulically-operated jack and direct-reading gauges requiring no calibration.
- H. Test Witnessing: All strength tests will be witnessed by the Engineer.

## **GENERAL SPECIFICATION 02501 REINFORCED CONCRETE SEWER PIPE**

---

- I. Costs of Tests: The Contractor shall pay all costs associated with tests and test witnessing.

### **PART 3 EXECUTION**

#### **3.01 INSTALLATION**

- A. Install all reinforced concrete sewer pipe, fittings and specials in accordance with the manufacturer's recommendations and approved shop drawings, and as follows.
  - 1. Precast pipe lines shall be true to line and grade. The interior surface shall be smooth and uniform.
  - 2. Season pipe 28 days prior to laying.
  - 3. With the gasket in place, align the pipe, and draw the joints home with an approved tackle and apparatus. Prior to the use of such apparatus and method, demonstrate to the Engineer for approval the effectiveness and practicability of the proposed method of drawing the joints home.
  - 4. The position and condition of the gasket will be examined from the inside of the pipe before successive pipe lengths are installed. If an unsatisfactory condition is located, the pipe shall be taken out and the operation of drawing the pipe together repeated with a new gasket.
  - 5. Provide approved concrete sills for the temporary support of pipes which are to be permanently supported on concrete cradles for maintaining proper alignment and grade until the concrete cradle is poured. Completely embed such sills in the concrete cradle.
  - 6. Cast concrete cradles for pipe in one pour to the exact size and dimensions shown on the Contract Drawings.
- B. Jointing Pipe at Structures:
  - 1. At manholes and other structures in precast concrete pipe lines, the construction may be of monolithic concrete. Submit details of such joints to the Engineer for approval.
  - 2. Where precast concrete pipe for pressure pipe lines is joined to monolithic concrete pipe, cast iron or steel pipe, or other structure, the joint shall be similar to the joint between individual precast concrete pipes, enlarged if required. Submit details of such joints to the Engineer for approval.
  - 3. Where provisions for future connections are required, provide similar joints and coat with an approved asphaltic compound for protection. If necessary, in the opinion of the Engineer, place a suitable collar entirely around the pipe at all such joints.

## **GENERAL SPECIFICATION 02501 REINFORCED CONCRETE SEWER PIPE**

---

### 3.02 LEAKAGE TESTS

- A. Test the reinforced concrete sewers for leakage after completion in accordance with General Specification 02505 - Leakage Tests.

### 3.03 SCHEDULES

- A. Refer to the schedule contained in the Detailed Specifications for information on the piping that is to be constructed using the pipe materials and methods specified herein.

END OF SECTION

**GENERAL SPECIFICATION 02501 REINFORCED CONCRETE SEWER PIPE**

---

NO TEXT ON THIS PAGE

SECTION 02502

Vitrified Clay Pipe Sewers

PART 1 GENERAL

1.01 SECTION INCLUDES

- A. The Contractor shall furnish and install all clay pipe and fittings, including perforated clay pipe. Clay pipe and fittings shall be used only where specifically shown or specified.
- B. The following index of this Section is included for convenience:

<u>Article</u>	<u>Title</u>	<u>Page</u>
		02502-
PART 1	GENERAL.....	1
1.01	Section Includes.....	1
1.02	Related Sections.....	1
1.03	Payment.....	1
1.04	References.....	2
1.05	Submittals.....	2
1.06	Quality Assurance.....	2
PART 2	PRODUCTS.....	3
2.01	Manufacturers.....	3
2.02	Materials.....	3
PART 3	EXECUTION.....	4
3.01	Installation.....	4
3.02	When No Cradle Is Required.....	4
3.03	Concrete Cradle.....	4
3.04	Broken Stone Or Gravel Cradle.....	4
3.05	Sewer To Be Kept Clean.....	4
3.06	Exposed End To Be Covered.....	5
3.07	Field Quality Control.....	5
3.08	Schedules.....	5

1.02 RELATED SECTIONS

- A. General Specification 02505 - Leakage Tests

1.03 PAYMENT

- A. Payment for vitrified clay pipe sewers will be made as provided for in the Detailed Specifications.
- B. No direct payment will be made for jointing materials; the cost thereof shall be included in the price for vitrified clay pipe sewers.

## GENERAL SPECIFICATION 02502 – VITRIFIED CLAY PIPE SEWERS

---

### 1.04 REFERENCES

- A. ASTM C12 - Standard Practice for Installing Vitrified Clay Pipe Lines
- B. ASTM C425 - Compression Joints for Vitrified Clay Pipe and Fittings
- C. ASTM C700 - Vitrified Clay Pipe, Extra Strength, Standard Strength, and Perforated

### 1.05 SUBMITTALS

- A. The Contractor shall submit Shop Drawings and the following:
  - 1. Complete detailed drawings, including piping layouts and schedules of all pipe.

### 1.06 QUALITY ASSURANCE

- A. Crushing Strength Tests:
  - 1. For crushing strength tests, the Engineer will select one pipe length from each one hundred lengths of each pipe diameter manufactured as required for this Contract. Where less than one hundred lengths of pipe are to be required for any pipe diameter, at least one pipe length will be selected for testing purposes, however, the Engineer may waive this requirement at his discretion.
  - 2. The test specimen shall be tested for crushing strength by the three-edge bearing method. The minimum crushing strength required will be those strengths listed in Table 1 of ASTM C700.
  - 3. The tests shall be performed at the manufacturer's plant on an approved and certified testing machine with a hydraulically-operated jack and direct reading gauges requiring no calibration, supplied by the manufacturer.
  - 4. The Engineer will reject all pipe of the lot from which the tested length specimen has been taken if the actual strength of the pipe tested fails to meet the three-edge load bearing strength test requirements. However, the Contractor may request that two other lengths of pipe be tested representing the same lot. The Engineer will select these two lengths of pipe. Should the tests on these two lengths of pipe prove satisfactory, the lot, represented by these lengths of pipe will be accepted. Should the tests on one or both of these lengths of pipe prove unsatisfactory, no further test on any other lengths of pipe from this lot will be made, and all the pipe in this particular lot will be rejected.



5. Pipe shall not be released from the manufacturer's plant for shipment to the work site until the results of the tests are certified by the Engineer. All tests on pipe shall be witnessed by the Engineer.

**PART 2 PRODUCTS**

**2.01 MANUFACTURERS**

- A. Vitrified Clay pipe sewers shall be as manufactured by:
  1. Logan Clay Products Company, Logan, Ohio
  2. Superior Clay Corporation, Uhrichsville, Ohio
  3. Or approved equal.

**2.02 MATERIALS**

- A. Clay pipe and fittings shall meet the requirements of ASTM C700. Extra strength pipe shall be provided unless otherwise specified. Perforated clay pipe shall be used only where specifically shown or specified.
  1. No more than one brand of pipe for any one size will be permitted.
  2. Pipe shall be free from laminations and surface roughness.
  3. Minimum laying length of pipe shall be 3 feet.
- B. Joints shall be compression type joints meeting the requirements of ASTM C425.
- C. Marking. All pipe shall be marked and identified with the following data as required by ASTM C700: class of pipe, the name of the manufacturer, and the factory at which it was made. Any pipe arriving at the location of the work without this information will be rejected.
- D. Shape. The pipe shall be bell and spigot pattern. The bells shall be true circular and concentric with the barrel of the pipe, and the planes of the ends shall be at right angles to the axis of the pipe. Butt joints with collars shall be used only when indicated or specified.
- E. Glazing. The pipe shall be smoothly salt-glazed over the entire inner and outer surfaces, except that the inner surface of the socket and the outer surface of the spigot end may be unglazed for two-thirds the depth of the socket.
- F. Scoring. The inner surface of the socket and outer surface of the spigot end, if glazed, shall be scored in conformity with ASTM C700.

**PART 3 EXECUTION**

**3.01 INSTALLATION**

- A. All clay pipe shall be installed in accordance with ASTM C12, the manufacturer's recommendations and approved shop drawings. When so indicated, specified or required, the sewer shall be encased in concrete.
- B. No section of sewer shall be laid before the subgrade or cradle has been approved by the Engineer.
- C. Pipe sections shall be laid with ends abutting and shall be fitted together and matched so that when laid in the work they will form a sewer with a smooth and uniform invert. Unless otherwise permitted or directed, not less than 15 feet of pipe sewer shall be laid in one operation.

**3.02 WHEN NO CRADLE IS REQUIRED**

- A. When the sewer is to be laid without a cradle, the bottom of the trench shall be excavated to fit the lower third of the pipe and to receive the bell. All irregularities in the bottom of the trench shall be filled up to the required grade with suitable material and the pipe shall then be evenly bedded therein.

**3.03 CONCRETE CRADLE**

- A. Concrete cradles for pipe shall be cast in one pour to the exact sizes and dimensions shown on the Contract Drawings.
- B. Concrete sills of approved shapes and dimension shall be used for the temporary support of pipes which are to be permanently supported on concrete cradles. Such sills shall be completely imbedded in the concrete cradle. Working drawings of these sills shall be submitted for approval before pipe laying begins.

**3.04 BROKEN STONE OR GRAVEL CRADLE**

- A. When the sewer is to be laid in a gravel or broken stone cradle, the cradle shall consist of clean gravel or sound broken stone, all of which shall pass through a 1-1/4-inch mesh screen and be retained on a 3/8-inch mesh screen.
- B. The stone shall be deposited and tamped for the full width of the trench to the required height. The pipe shall then be bedded therein and the remainder of the stone deposited and carefully tamped in such a manner as to avoid disturbing the sewer.

**3.05 SEWER TO BE KEPT CLEAN**

- A. The interior of the sewer shall be kept clean of all dirt, cement and superfluous materials as the work progresses.

**3.06 EXPOSED END TO BE COVERED**

- A. During the progress of the work, the exposed end of the sewer shall be provided with an approved temporary cover to exclude earth and other materials.

## **GENERAL SPECIFICATION 02502 – VITRIFIED CLAY PIPE SEWERS**

---

- B. The dead end of the sewer shall be closed with a bulkhead of 8-inch thick brick masonry, or vitrified clay.
- 3.07 FIELD QUALITY CONTROL
- A. Clay pipelines shall be tested for leakage as specified in General Specification 02505 – Leakage Tests.
- 3.08 SCHEDULES
- A. Refer to the schedule contained in the Detailed Specifications for information on the piping that is to be constructed using the pipe materials and methods specified herein.

END OF SECTION

**GENERAL SPECIFICATION 02502 – VITRIFIED CLAY PIPE SEWERS**

---

NO TEXT ON THIS PAGE

**GENERAL SPECIFICATION 02504 SANITARY AND STORM SEWER  
STRUCTURES**

---

**SECTION 02504  
Sanitary and Storm Sewer Structures**

**PART 1 GENERAL**

**1.01 SECTION INCLUDES**

- A. Requirements for furnishing and installing precast and cast-in-place manholes, catch basins, trench drains, and other structures in sanitary sewers and storm sewers including all appurtenances.
- B. Concrete drainage structures include, but are not limited to, inlets, catch basins, trench drains, area drains, manholes, pipe cradles and encasements, and splash pads.
- C. The following index of this Section is included for convenience:

<u>Article</u>	<u>Title</u>	<u>Page</u>
		02504-
PART 1	GENERAL .....	1
1.01	Section Includes .....	1
1.02	Payment.....	1
1.03	Related Sections.....	1
1.04	References.....	2
1.05	Design Requirements .....	3
1.06	Submittals .....	3
1.07	Delivery, Storage And Handling.....	3
PART 2	PRODUCTS.....	3
2.01	Manufacturers .....	3
2.02	Materials .....	4
2.03	Construction Of Manholes .....	6
2.04	Source Quality Control .....	6
2.05	Precast Products .....	7
PART 3	EXECUTION.....	7
3.01	Installation.....	7
3.02	Manufacturer’s Services .....	8

**1.02 PAYMENT**

- A. Unless otherwise provided in the Detailed Specifications, no separate payment will be made for performing any Work required under this Section and the Contractor shall include all costs thereof shall be included in the lump sum price Contract.

**GENERAL SPECIFICATION 02504 SANITARY AND STORM SEWER  
STRUCTURES**

---

1.03 RELATED SECTIONS

- A. General Specification 02505 - Leakage Tests
- B. General Specification 03210 - Reinforcing Steel
- C. General Specification 03300 - Cast-in-Place Concrete
- D. General Specification 05561 - Miscellaneous Metal Castings

1.04 REFERENCES

- A. ASTM C32 - Sewer and Manhole Brick (Made from Clay or Shale)
- B. ASTM C39 - Standard Test Method for Compressive Strength for Cylindrical Concrete Specimens
- C. ASTM C78 - Standard Test Method for Flexural Strength of Concrete (Using Simple Beam with Third-Point Loading)
- D. ASTM C139 - Concrete Masonry Units for Construction of Catch Basins and Manholes
- E. ASTM C140 - Standard Test Methods for Sampling and Testing Concrete Masonry Units and Related Units
- F. ASTM C144 - Aggregate for Masonry Mortar
- G. ASTM C279 - Chemical-Resistant Masonry Units
- H. ASTM C443 - Joints for Concrete Sewer and Manholes, Using Rubber Gaskets
- I. ASTM C478 - Circular Precast Reinforced Concrete Manhole Sections
- J. ASTM C666 - Standard Test Method for Resistance of Concrete to Rapid Freezing and Thawing Freeze Thaw Stability of Concrete Specimens
- K. ASTM D1785 - Poly (Vinyl Chloride) (PVC) Plastic Pipe, Schedules 40, 80, and 120
- L. AWWA C302 - Reinforced Concrete Pressure Pipe, Non-cylinder Type
- M. City of New York Department of Environmental Protection Sewer Design Standards

1.05 DESIGN REQUIREMENTS

- A. Except as otherwise shown or specified, construct sewer manholes and catch basins of precast reinforced concrete sections conforming to ASTM C478.

**GENERAL SPECIFICATION 02504 SANITARY AND STORM SEWER  
STRUCTURES**

---

- B. Unless otherwise shown, manholes and catch basins shall be built in accordance with the Sewer Design Standards of the Department of Environmental Protection, except that they shall be constructed without steps.
- C. Trench drains shall be constructed of precast, interlocking modular components.
- D. Fiberglass trench drains shall be constructed of resin vinylester suitable for 15% sodium hypochlorite at 100°F with a resin of Hetron 922 or approved equal.

1.06 SUBMITTALS

- A. Contractor shall submit Shop Drawings and material specifications for the approval of the Engineer. Submittals shall include, but not be limited to:
  - 1. Shop and field test reports of concrete samples tested in an approved laboratory.

1.07 DELIVERY, STORAGE AND HANDLING

- A. General: Take every precaution to prevent injury to the structures during transportation and unloading. Unload manhole sections and other precast items using skids, pipe hooks, rope slings, or suitable power equipment, if necessary, and keep the items under control at all times. Do not allow the items to be dropped, dumped or dragged under any conditions. Follow applicable requirements specified in Contract Documents Damaged Section: If any precast manhole section or other structural unit is damaged in the process of transportation or handling, reject and immediately remove the item from the site, and replace it at no increase in Contract Amount.

PART 2 PRODUCTS

2.01 MANUFACTURERS

- A. Polymer Concrete Trench Drains shall be as manufactured by:
  - 1. ABT, Inc., Troutman, NC.
  - 2. ACO Polymer Products, Inc., Chardon, OH.
  - 3. Or approved equal
- B. Fiberglass Trench Drains shall be as manufactured by:
  - 1. ACO Polymer Products, Inc., Chardon, OH.
  - 2. Aqueduct, Inc., Waltham, MA.
  - 3. Or approved equal
- C. Precast Manholes shall be as manufactured by:
  - 1. Monarch Precast Concrete Corp., Allentown, PA
  - 2. Precast Concrete Sales Company, Valley Cottage, NY

**GENERAL SPECIFICATION 02504 SANITARY AND STORM SEWER  
STRUCTURES**

---

3. Long Island Precast, Inc., Holtsville, NY.
  4. Or approved equal
- D. Precast Inlets shall be as manufactured by:
1. Monarch Precast Concrete Corp., Allentown, PA
  2. Penn-Cast Products, Inc., Fredericksburg, VA
  3. Precast Concrete Sales Company, Valley Cottage, NY
  4. Or approved equal
- E. Precast Catch Basins shall be as manufactured by:
1. Monarch Precast Concrete Corp., Allentown, PA
  2. Penn-Cast Products, Inc., Fredericksburg, VA
  3. Long Island Precast, Inc., Brookhaven, NY
  4. Precast Concrete Sales Company, Valley Cottage, NY
  5. Or approved equal

2.02 MATERIALS

- A. Concrete, Steel Reinforcement and Aggregates: For precast manholes, catch basins, inlets, and other sanitary and storm sewer structures, reinforced concrete, cementitious materials, aggregates and steel reinforcement shall conform to the requirements of ASTM C478. If concrete rings are used for adjusting manhole frames to grade, they shall conform to the requirements of ASTM C139. For cast-in-place structures, these materials shall conform to General Specifications 03300 – Cast-in-Place Concrete and 03210 – Reinforcing Steel.
- B. Brick: If brick is used for adjusting manhole and catch basin frames to grade, it shall conform to ASTM C32, Grade MS, with minimum dimensions of 2 1/4 by 3 1/2 by 7 1/2 inches. Brick shall be new, solid, sound, hard burned throughout and uniform in size and quality.
- C. Mortar: Provide mortar that is composed of one part Type II Portland cement or Portland pozzolan cement to two parts sand. Sand shall be natural sand that conforms to the requirements of ASTM C144.
- D. Frames and Covers: Frames, covers, gratings and miscellaneous metal castings shown in the Sewer Design Standards or on the Contract Drawings for installation on manholes, catch basins, trench drains and other sanitary structures shall be gray iron and shall meet the requirements of General Specification 05561- Miscellaneous Metal Casting. Grating for trench drains shall be compatible with the trench drain manufacturer's systems and recommendations.



**GENERAL SPECIFICATION 02504 SANITARY AND STORM SEWER  
STRUCTURES**

---

- E. O-Ring Rubber Gaskets: Provide O-ring rubber gaskets conforming to ASTM C443 for joining manhole sections.
- F. Polymer Concrete Trench Drains.
  - 1. The trench drain shall be formed from high strength, durable polymer concrete, meeting or exceeding the following requirements:.

<b>Property</b>	<b>ASTM Designation</b>	<b>Polymer Concrete</b>
Compressive Strength	C39	14,000 psi
Tensile Strength	C78	1,500 psi
Freeze Thaw	C666	1,700 cycles (no weight loss)
Chemical Resistance	C279	Resistant to most acids and alkali
Absorption of Moisture	C140	Less than 0.2 (surface wetting only)

- 2. Sealant for Polymer Concrete Trench Drains. Joints between channel sections shall be sealed during installation with a material recommended by manufacturer.
- G. Fiberglass Trench Drains:
  - 1. Fiberglass trench drains shall be manufactured from fiberglass reinforced plastic utilizing vinylester. FRP fabrication shall be of the hand lay-up type. The trench drain systems utilizing polymer resins with aggregate or sand are not acceptable. To reduce air entrapment, no pigment shall be used on the resin system. A double synthetic veil shall be provided on the inner trench surfaces and an ultraviolet inhibitor shall be provided. Cobalt compounds shall not be used in any way.
  - 2. The trench drains shall have a built-in slope of not less than 1%, and shall be furnished in modular lengths of 6 feet. Modules shall have a bottom radius of not less than 2 inches expanding to a nominal inlet opening of 8 inches. Modules shall be joined together with a lap joint not less than 2 inches to provide a positive seal, and joint shall be designed so as to minimize disturbance of flow. Joints between channel sections shall be sealed during installation with a material recommended by manufacturer.
  - 3. Channel modules shall incorporate flanges predrilled to accept the appropriate grate frame, as specified. Frames shall be of all welded construction with welded stainless steel concrete anchors and threaded for grate lockdown.

## GENERAL SPECIFICATION 02504 SANITARY AND STORM SEWER STRUCTURES

---

- 4. Written certification from the manufacturer is required for each of the specified materials and fabrication techniques.
- H. Trench Drain Inlet and Outlets. Size and arrangement shall be as shown on Contract Drawings or as specified in Detailed Specifications.

### 2.03 CONSTRUCTION OF MANHOLES

- A. Manhole Base Section: Unless otherwise shown, provide manhole base sections consisting of a base riser section with an integral floor. When benches are made at the manufacturing site, provide concrete used for benched inverts conforming to the requirements for concrete used for precast sections. When benches are made in the field, Class 45 concrete may be used. Benches shall be float finished and sloped to drain.
- B. O-ring Joints: Join riser, cone and flat slab top sections with O-ring rubber gasket joints or selfsealing butyl gaskets, as shown in the Sewer Design Standards. Fill voids in the joints completely with mortar after assembly of the sections.

### 2.04 SOURCE QUALITY CONTROL

- A. Concrete Strength: Manhole sections will be inspected and tested by an independent, certified testing laboratory, retained by the City, to establish the strength of the concrete and the adequacy of curing, to certify the date that the sections were cast and to confirm that the reinforcing steel has been properly placed. This inspection and testing will be performed by the laboratory at the manufacturing plant prior to shipment.
  - 1. A minimum of one set of three cylinders will be taken each day that manhole sections are cast, with batch samples to be designated by the laboratory representative. At least one set of cylinders will be taken from each 9 cubic yards of concrete used in manhole section construction. These samples will be tested for strength. If the samples fail to meet specified minimum concrete strength requirements, all manhole sections manufactured from the concrete from which the cylinders were made will be rejected.
  - 2. The City reserves the right to core manholes either at the job site or point of delivery to validate strength of concrete and placement of steel. If cores fail to demonstrate the required strength or indicate incorrect placement of reinforcing steel, all sections not previously tested will be considered rejected until sufficient additional cores are tested, at no increase in Contract Amount, to substantiate conformance to these requirements.
- B. Acceptance of flat slab tops will be based on the tops passing a proof-of-design test in accordance with ASTM C478. One flat slab top for each design shall be tested.

**GENERAL SPECIFICATION 02504 SANITARY AND STORM SEWER  
STRUCTURES**

---

2.05      PRECAST PRODUCTS

- A.      Unless otherwise shown or specified, precast concrete products shall be used for sanitary and storm sewer structures.
- B.      The number of joints in manhole and catch basin riser sections shall be kept to a minimum by using sections 8'-0" long in so far as possible. Joints shall be tongue and groove type conforming to AWWA C302, with continuous steel reinforcement in the tongue and bell.
- C.      Wet-cast methods only shall be used. Forms shall leave the surfaces smooth and free of irregularities or honeycombing.
- D.      Unless otherwise shown or specified, the following design loadings shall be used with 30 percent impact allowance in roads and 15 percent elsewhere.
  - 1.      Earth      =      130 PC
  - 2.      Wheel      =      H-20
- E.      Unless otherwise shown or specified, wall thickness for manholes and catch basins shall be not less than:
  - 1.      5 inches for walls
  - 2.      8 inches for top slab
- F.      No more than two (2) tapered lifting holes shall be provided per section of manhole or lifting holes shall be filled with tapered rubber plugs.
- G.      The point of intersection (P.I.) of pipes shall be marked with a pin in the manhole floor.
- H.      The date of manufacture and the manufacturer's trademark shall be marked inside each manhole and catch basin barrel.

PART 3      EXECUTION

3.01      INSTALLATION

- A.      Manhole Frames: Firmly embed manhole frames in mortar. Provide wedges or shims for accurate and level placing of the frames.
- B.      Connections to Riser Section: Manufacture riser sections with openings properly located for making connections to sewers. The minimum distance between a joint in a manhole section and the nearest edge of an opening for a connecting sewer and the diameter of such openings shall be as shown in the Sewer Design Standards.
- C.      Coatings: Precast structures below grade shall be coated with coal tar epoxy applied in two (2) coats, eight (8) mils each.
- D.      Laying Masonry:
  - 1.      Bricks shall be wetted before applying mortar.

## GENERAL SPECIFICATION 02504 SANITARY AND STORM SEWER STRUCTURES

---

2. Full bed, end and side joints shall be formed in one operation.
  3. Horizontal joints shall be 3/8 inch maximum and radial joints shall be 1/4 inch maximum.
  4. Keyways shall be completely filled with mortar.
  5. The total amount of adjustment by bricks or concrete rings shall not exceed 12 inches.
- E. Precast Items:
1. Place on crushed stone bed or concrete cradle set level as shown.
  2. Place backfill in even lifts on all sides to prevent overturning loads.
- F. Stubs for Future Connections: Where shown, provide stubs or bells cast in walls and provide approved plugs or caps.
- G. Trench Drains: Follow manufacturer's recommendations for installation methods. Forming system for fiberglass trench drains shall be designed so that no portion of fiberglass form is exposed to traffic upon completion of installation.
- H. Grading:
1. Manholes and catch basins shall be installed such that covers will be at final grade.
  2. Structures shall not project above finished pavements.
  3. Structures in areas with temporary working grades shall be initially installed to match the temporary grade, and adjusted later to final grade prior to regrading.
  4. Contractor shall be responsible for setting structures to the proper grade. The Engineer's review will be general and will apply to components only.
- I. Test for leakage as required by General Specification 02505 – Leakage Tests.
- 3.02 MANUFACTURER'S SERVICES
- A. If a fiberglass trench drain system is provided, the Contractor shall furnish the services of an accredited representative of the fiberglass trench drain system manufacturer for the period specified in the Detailed Specifications to supervise the installation.

END OF SECTION

**SECTION 02505  
Leakage Tests**

**PART 1 GENERAL**

**1.01 SECTION INCLUDES**

- A. Leakage testing for all pipelines and structures required to be watertight or airtight.
- B. The following index of this Section is included for convenience:

<u>Article</u>	<u>Title</u>	<u>Page</u>
		02505-
PART 1	GENERAL .....	1
1.01	Section Includes .....	1
1.02	Payment.....	1
1.03	References.....	1
1.04	Performance Requirements.....	2
1.05	Submittals .....	2
PART 2	PRODUCTS (NOT USED) .....	2
PART 3	EXECUTION.....	2
3.01	General.....	2
3.02	Pressure Tests Of Exposed Piping .....	3
3.03	Pressure Tests Of Buried Or Concealed Pipelines.....	3
3.04	Valve Testing.....	4
3.05	Leakage Tests For Gravity Sewers .....	4
3.06	Repair Of Piping Leaks.....	5
3.07	Leakage Tests For Concrete Structures .....	5
3.08	Leakage Tests For Non-Concrete Structures .....	8

**1.02 PAYMENT**

- A. Unless otherwise provided in the Detailed Specifications, no separate payment will be made for performing any work required under this Section and the Contractor shall include all costs thereof in its lump sum price bid for the Contract.

**1.03 REFERENCES**

- A. ACI 350.1-10 - Specification for Tightness Testing of Environmental Engineering Concrete Containment Structures and Commentary
- B. AWWA C600-10 - Installation of Ductile-Iron Mains and Their Appurtenances

## GENERAL SPECIFICATION 02505 LEAKAGE TESTS

---

C. New York City Building Code

### 1.04 PERFORMANCE REQUIREMENTS

- A. Written Notification of Testing: Provide written notice at least two weeks prior to date of testing.
- B. No tests shall be conducted without an approved written procedure.
- C. All leakage tests shall be conducted in the presence of the Engineer. The tests shall be repeated in the presence of local authorities having jurisdiction if required.
- D. The Contractor shall furnish all labor, equipment, air, water and materials, including meters, gauges, blower, pumps, compressors, fuel, water, bulkheads, temporary weirs, valves, plugs and accessory equipment.

### 1.05 SUBMITTALS

- A. The Contractor shall submit Shop Drawings and the following:
  - 1. Testing procedures shall be submitted for approval at least 30 days prior to the test.
  - 2. Testing Report: Prior to placing the piping system or structure in service, submit for review and approval a detailed bound report summarizing the leakage test data, describing the test procedure and showing the calculations on which the leakage test data is based.

## PART 2 PRODUCTS (NOT USED)

## PART 3 EXECUTION

### 3.01 GENERAL

- A. All pipelines and structures required to be watertight or airtight shall be tested for leakage. Piping and structures which fail the leakage test shall be repaired or replaced to the satisfaction of the Engineer and retested until leakage test results are acceptable.
- B. Operation of Existing Facilities: Conduct all tests in a manner to minimize as much as possible any interference with the day-to-day operations of existing facilities or other contractors working on the site.
- C. Test gravity sewers and drain lines by an Infiltration Test as specified.
- D. Test air and gas lines with compressed air.
- E. Test all other pipelines, including outfall sewers, with water under the specified pressures.
- F. Test vents and drains in plumbing systems and all cast iron soil pipe lines in accordance with Section C26-1606.0 of the New York City Building Code

## GENERAL SPECIFICATION 02505 LEAKAGE TESTS

---

unless otherwise specified. Unless specified otherwise, test all vents and drains on process piping as for plumbing systems.

- G. Leakage in pipelines of other than circular section shall not exceed an amount based on a circular section having an equivalent inner perimeter.

### 3.02 PRESSURE TESTS OF EXPOSED PIPING

- A. Testing: Pressure test exposed pipelines for leakage by the hydrostatic testing method only. The hydrostatic test shall be of at least 2-hour duration at the pressure rating for the pipe and joints as specified by the manufacturers. Examine all accessible joints during the test.
- B. Test Pressures: Test the various pipelines for leakage in accordance with the requirements for hydrostatic testing in AWWA or other applicable standards as specified in the Detailed Specifications or approved by the Engineer.
- C. Leakage: Stop all visible leakage.

### 3.03 PRESSURE TESTS OF BURIED OR CONCEALED PIPELINES

- A. Testing:
  - 1. Completely backfill all harnessed sections of buried piping before such sections are tested. Non-harnessed sections of buried piping shall be tested before backfilling.
  - 2. Pressure test buried or concealed pipelines for leakage by maintaining the fluid in the pipe at the specified pressure for a minimum period of 4 hours.
  - 3. Pressure test the piping for leakage as a whole or in sections, valved or bulkheaded at the ends. Apply the specified pressure to the piping through a tap in the pipe by means of a hand pump or other approved method.
    - a. Do not use air for testing.
- B. Test Pressures: Test the pipelines at pressures specified in the Detailed Specifications or in accordance with standards approved by the Engineer.
- C. Leakage: Do not allow leakage for any piping, as determined by the above test, to exceed the testing allowance given by the following formula in AWWA Standard C600, Installation of Ductile-Iron Mains and Their Appurtenances:

$$L = \frac{SD\sqrt{P}}{148,000}$$

Where:

$L$  = testing allowance (makeup water), in gallons per hour  
 $S$  = length of pipe tested, in feet  
 $D$  = nominal diameter of the pipe, in inches

## GENERAL SPECIFICATION 02505 LEAKAGE TESTS

---

$P$  = average test pressure during the hydrostatic test, in pounds per square inch (gauge)

### 3.04 VALVE TESTING

- A. Testing: Operate valves in the section under test through several complete cycles of closing and opening. In addition, have the test pressure for each valve, when in the closed position, applied to one side of the valve only. Test each end of the valve in this manner.
- B. Test Pressure: Test each valve at the same test pressure as that specified for the pipe in which the valve is installed.
- C. Leakage: Stop all external and internal leakage through the valves.
- D. Movement: Stop all valve movement or structural distress.

### 3.05 LEAKAGE TESTS FOR GRAVITY SEWERS

- A. Submerged Testing Procedure: When the groundwater level is above the sewer, test sewers for infiltration as follows:
  - 1. Measure the infiltrated flow of water by means of a weir set up in the invert of the sewer at a known distance from a temporary bulkhead or other limiting point of infiltration.
  - 2. Test after the sewer or sewers have been pumped out, if necessary.
  - 3. Do not start testing until normal infiltration conditions are established in the work to be tested.
    - a. Inspect gravity sewer visually for infiltration.
    - b. Pump the sewers dry and make sure the groundwater level is above the crown of the sewer.
    - c. Inspect the sewer on the inside and seal all visible leaks completely.
- B. Non-submerged Testing Procedure: If the groundwater level is below the top of the sewer, test for leakage as follows:
  - 1. Construct a bulkhead in the sewer at the manhole at the lower end of the section under test.
  - 2. Fill the section being tested with water until the level of water is four feet above the crown of the sewer in the manhole at the upper end of the test section. For concrete sewers, allow the water to remain in the piping for at least 12 hours before conducting the tests.
  - 3. Leakage will be the measured amount of water added to maintain the water at that level.



## GENERAL SPECIFICATION 02505 LEAKAGE TESTS

---

- C. Carry on tests for a minimum of eight hours with readings at 60-minute intervals.
  - D. In computing the length of sewer contributing infiltration or leakage, include the length of house connections tested, if any, in the total length.
  - E. The leakage exfiltration or infiltration for sewers shall not exceed 100 gallons per inch of diameter per mile per 24 hours for any section of the sewer system. The exfiltration or infiltration test shall be performed with a minimum positive head of 24 inches.
  - F. Repair: When the measured infiltration or leakage exceeds the specified amount, locate and repair defective manholes, pipe or pipe joints. If the defective portions cannot be located, remove and reconstruct as much of the original work as necessary to obtain a sewer within the allowable infiltration limits upon such retesting as necessary.
    - 1. Regardless of the amount of infiltration or leakage measured, repair and seal in an approved manner all visible or detectable leaks in the sewers, manholes, structures, and other appurtenances.
- 3.06 REPAIR OF PIPING LEAKS
- A. Procedures: Repair leaks as follows:
    - 1. Replace broken pipe or joint assemblies found to leak.
    - 2. When leakage occurs in excess of the specified amount, locate and repair defective valves, pipe, cleanouts or joints.
    - 3. If defective portions cannot be located, remove and reconstruct as much of the original work as necessary to obtain piping that meets the leakage requirements specified herein and retest, all at no addition to the Contract Price.
- 3.07 LEAKAGE TESTS FOR CONCRETE STRUCTURES
- A. Leakage tests of wet wells, tanks, channels, containment areas, and other water retaining structures shall be performed following the requirements of ACI 350.1 and as specified herein. The Contractor shall supply all materials and labor needed to conduct the test as directed by the Engineer.
  - B. Prior to start of leakage testing, the following requirements shall be met.
    - 1. All elements of the structure which resist any portion of the retained liquid pressure shall be in place and at specified strength levels. All concrete shall be fully cured.
    - 2. Structure walls shall not be backfilled prior to leakage testing.
    - 3. All valves, gates, blind flanges, and other non-concrete items which control the flow or otherwise retain the liquid contents of the structure,

## GENERAL SPECIFICATION 02505 LEAKAGE TESTS

---

shall be checked for watertightness. If not watertight, means shall be taken to assure watertightness during the period of the leakage test.

4. The portions of the structure to be tested shall be cleaned of all construction debris, standing water, soil, foreign materials and any other material which interferes with the exposed concrete surfaces of the structure.
  5. Defective concrete shall be repaired.
  6. The Contractor shall notify the Engineer a minimum of 24 hours prior to start of filling of structure for leakage testing. Leakage testing shall not start until the structure is inspected by the Engineer.
- C. Filling the Structure with Water
1. The portion of the structure to be tested shall be filled at a rate not to exceed two feet per hour.
  2. The structure shall be filled to the normal operating depth of the structure as indicated on the Contract Drawings. Where no operating depth is indicated or where operating depth is controlled by flowing over a weir, the structure shall be filled to a depth 6 inches below the weir or top of wall elevation whichever is lower.
  3. Water in the structure shall be maintained at the specified test elevation for a minimum of three days prior to the start of the leakage test.
- D. After water has been brought to the test elevation, the exposed elements of the structure shall be inspected for leakage. All locations which exhibit any amount of leakage flow shall be repaired prior to the start of leakage testing.
- E. The leakage test duration shall be determined by the Engineer based on ACI 350.1 but shall not be less than 3 days.
- F. Leakage Allowance
1. For unlined concrete structures, the maximum allowable leakage rate shall be 0.075 percent of the volume per 24-hour period.
  2. For concrete structures with walls lined by a waterproof material, the maximum allowable leakage rate shall be 0.050 percent of the volume per 24-hour period.
- G. Test Locations
1. Structure cells which are less than 1000 square feet in area shall have measurements of water level taken at two locations which are located approximately 180 degrees apart.

## GENERAL SPECIFICATION 02505 LEAKAGE TESTS

---

2. Structure cells which are greater than 1000 square feet in area shall have measurements of water level taken at four locations which are located approximately 90 degrees apart.
  3. Each test location shall be marked and given a reference number. A reference point shall be marked on the face of the wall above the test water surface in a manner which will prevent its movement or deterioration during the period of the test.
  4. Test locations must be approved by the Engineer.
- H. Evaporation and Precipitation Measuring
1. In open structures, a clear plastic calibrated open-top container not less than 18 inches in diameter and depth shall be partially filled, floated in the tank, and held in position near each measurement location.
  2. The container shall be located so as not to be shaded by tank walls and away from any items passing over it such as beams or pipes.
- I. Test Measurements
1. Leakage tests shall not be started when periods of severe weather conditions or major changes in average daily temperature are predicted.
  2. The following measurements shall be recorded at each test location at the start of the test period and at 24-hour intervals thereafter:
    - a. Distance from reference point to test water surface
    - b. Depth of water in the floating container
    - c. Temperature of the test water at 18 inches below water surface
    - d. Temperature of the water in the evaporation-precipitation container at mid-depth
- J. Leakage Determination
1. The change in water surface elevation at each test location shall be averaged and adjusted as follows.
  2. The total change in test water surface elevation shall be adjusted by the average change in water surface elevation in the evaporation-precipitation containers.
  3. Where averaged water temperature measurements vary by more than 3 degrees from start to completion of the test period, adjustment in tank volume shall be determined by change of water density resulting from the change in the average water temperature.

## GENERAL SPECIFICATION 02505 LEAKAGE TESTS

---

### K. Retesting

1. The leakage test shall be considered as failed if the specified leakage allowance is exceeded or if any leakage is observed.
2. If the test becomes unreliable due to excessive precipitation or other external factors, it shall be restarted.
3. If a leakage test fails, it may be retested immediately without repairs if approved by the Engineer. If subsequent leakage tests fail, the Contractor shall repair all probable areas of leakage and the leakage test shall be repeated. The structure shall be retested until it meets the specified leakage criteria. Repairs shall be made to the probable leakage areas before each retest.

### 3.08 LEAKAGE TESTS FOR NON-CONCRETE STRUCTURES

- A. Steel, poly and fiberglass-reinforced plastic tanks and similar structures shall be tested for leakage by bulkheading the openings and filling the structure with water to 6 inches below the overflow water level. The tank shall be kept full until the water temperature has stabilized, but not less than 24 hours before the start of the leakage test. The leakage test shall consist of measuring the water surface elevation from a fixed point on the tank at two locations 180 degrees apart. Measurements shall be taken at the start of the test and 24 hours later.
- B. Testing shall be performed before the installation of mechanical equipment and before applying any waterproofing coatings to the outside surfaces.
- C. The exterior surface of the structure shall be inspected for leakage, especially in areas around joints.
- D. Where environmental conditions could lead to changes in water level due to evaporation or precipitation, measurement of these factors shall be made as specified for testing concrete structures.
- E. The leakage test shall be considered failed if there is any measurable drop in the water surface (after adjusting for evaporation and precipitation) during the 24-hour test period or if there is any visible leakage.
- F. If visible leaks appear or if leakage exceeds the allowable limit, the structure shall be repaired by removing and replacing the leaking portions of the structure, waterproofing the inside, or by other approved methods. After repairs are complete, the test shall be repeated.

END OF SECTION

**SECTION 02741  
Asphaltic Concrete Pavements**

**PART 1 GENERAL**

**1.01 SECTION INCLUDES**

- A. The Contractor shall provide asphaltic concrete pavement roads and walks constructed on properly prepared subgrades and in conformance to the required lines, grades and typical cross sections shown on the Contract Drawings.
- B. The following index of this Section is included for convenience:

<u>Article</u>	<u>Title</u>	<u>Page</u>
		02741-
PART 1	GENERAL .....	1
1.01	Section Includes .....	1
1.02	Payment.....	1
1.03	References.....	2
1.04	Definitions.....	3
1.05	Submittals .....	3
1.06	Quality Assurance For Geotextile.....	4
1.07	Delivery, Storage And Handling Of Geotextile.....	4
PART 2	PRODUCTS.....	4
2.01	Manufacturers .....	4
2.02	Materials .....	4
2.03	Quality Control Of Geotextile .....	6
PART 3	EXECUTION.....	6
3.01	Roads.....	6
3.02	Walks .....	15
3.03	Pavement Samples .....	17
3.04	Patching.....	17
3.05	Cleaning And Protection.....	17
3.06	Pavement Marking.....	17

**1.02 PAYMENT**

- A. Unless otherwise provided in the Detailed Specifications, no separate payment will be made for performing any Work required under this Section and the Contractor shall include all costs thereof in its lump sum price bid for the Contract.

## GENERAL SPECIFICATION 2741 ASPHALTIC CONCRETE PAVEMENTS

---

### 1.03 REFERENCES

- A. ASTM D1557 - Standard Test Methods for Laboratory Compaction Characteristics of Soil Using Modified Effort (56,000 ft-lbf/ft<sup>3</sup> (2,700 kN-m/m<sup>3</sup>))
- B. ASTM D3786 - Standard Test Method for Bursting Strength of Textile Fabrics-Diaphragm Bursting Strength Tester Method
- C. ASTM D4253 - Standard Test Methods for Maximum Index Density and Unit Weight of Soils Using a Vibratory Table
- D. ASTM D4354 - Practice for Sampling of Geosynthetics and Rolled Erosion Control Products (RECPs) for Testing
- E. ASTM D4355 - Test Method for Deterioration of Geotextiles by Exposure to Light, Moisture and Heat in a Xenon Arc Type Apparatus
- F. ASTM D4439 - Terminology for Geosynthetics
- G. ASTM D4491 - Test Methods for Water Permeability of Geotextiles by Permittivity
- H. ASTM D4533 - Test Method for Trapezoid Tearing Strength of Geotextiles
- I. ASTM D4595 - Test Method for Tensile Properties of Geotextiles by the Wide-Width Strip Method
- J. ASTM D4632 - Test method for Grab Breaking Load and Elongation of Geotextiles
- K. ASTM D4759 - Practice for Determining the Specification Conformance of Geosynthetics
- L. ASTM D4751 - Test Method for Determining Apparent Opening Size of a Geotextile
- M. ASTM D4833 - Test Method for Index Puncture Resistance of Geomembranes and Related Products
- N. ASTM D4873 - Guide for Identification, Storage and Handling of Geosynthetic Rolls and Samples
- O. Federal Highway Administration (FHWA) - Geosynthetic Design and Construction Guidelines, Publication No. FHWA HI-95-038, May 1995
- P. Geosynthetic Accreditation Institute (GAI) - Laboratory Accreditation Program (LAP)

## GENERAL SPECIFICATION 2741 ASPHALTIC CONCRETE PAVEMENTS

---

- Q. International Standards Organization (ISO) 9001 - Quality management systems — Requirements
  - R. New York State Department of Transportation (NYSDOT) Standard Specifications
  - S. New York City Department of Transportation (NYCDOT), Bureau of Highway Operations Standard Specifications
  - T. Federal Specification TT-P-115 - Paint, Traffic, Highway, White and Yellow
- 1.04 DEFINITIONS
- A. California Bearing Ratio (CBR): The ratio of (1) the force per unit area required to penetrate a soil mass with a 19 sq. cm (3 sq.in.) circular piston (approximately 51 mm (2 in.) diameter) at the rate of 1.3mm/min (.05 in/min) to (2) that required for corresponding penetration of a standard material.
  - B. Minimum Average Roll Value (MARV): Property value calculated as typical minus two standard deviations. Statistically, it yields a 97.7 percent degree of confidence that any sample taken during quality assurance testing will exceed value reported.
  - C. Typical Roll Value: Property value calculated from average or mean obtained from test data.
- 1.05 SUBMITTALS
- A. The Contractor shall submit shop drawings and material specifications for the approval of the Engineer. Submittals shall include, but not be limited to:
    - 1. Manufacturer's literature including physical, mechanical and chemical properties of the geotextile.
    - 2. Certification of geotextile's minimum average roll values and tests used to determine those properties.
    - 3. Certificate of Compliance stating that the geotextile conforms to the Specifications and the manufacturer is aware of and agrees with its intended use.
    - 4. Geotextile manufacturer's qualifications: ISO 9001 certified or equivalent.
    - 5. Manufacturing quality control test results on geotextiles.
    - 6. The bituminous mix design for both the binder course and the wearing course, which shall include the sources of all ingredient materials, the penetration of the asphaltic cement and the percentages by weight and the number of pounds of each of the materials making up one batch.
    - 7. The laboratory analysis of the bituminous mix and the laboratory compacted density.

## GENERAL SPECIFICATION 2741 ASPHALTIC CONCRETE PAVEMENTS

---

### 1.06 QUALITY ASSURANCE FOR GEOTEXTILE

- A. Manufacturer Qualifications: The manufacturer shall be ISO 9001 certified. Provide proof of certification or demonstrate that the standards and experience required for certification are possessed, all to the satisfaction of the Engineer.

### 1.07 DELIVERY, STORAGE AND HANDLING OF GEOTEXTILE

- A. Wrap geotextile in black protective wrap.
- B. The geotextile rolls shall be labeled as per ASTM D4873.
- C. Deliver, store and handle rolls in manner to prevent damage.
- D. After unloading, inspect rolls for defects and damage.
- E. Do not leave covered rolls exposed to elements for more than 30 days unless additional heavy-duty waterproof cover is provided. At no time shall the geotextile be exposed to ultraviolet light for a period exceeding 14 days.
- F. Store rolls off ground, protected from precipitation, ultraviolet radiation, strong chemicals, sparks and flames, temperatures in excess of 71 degrees C (160 degrees F) and other environmental conditions that could cause damage to geotextile.
- G. Prevent damage to wrappings and geotextile.

## PART 2 PRODUCTS

### 2.01 MANUFACTURERS

- A. Geotextiles shall be as manufactured by:
  1. Amoco Fabrics & Fibers Co. Amoco 2006, Austell, GA.
  2. Nicolon Mirafi Group/600X, Pendergrass, GA.
  3. Synthetic Industries/Geotex315ST, Chickamauga, GA.
  4. Or approved equal

### 2.02 MATERIALS

- A. Geotextile: Provide geotextile fabric conforming to the requirements specified in this section:
  1. Woven slit film polypropylene geotextile; individual slit films woven together in manner to provide dimensional stability relative to each other.
  2. Resistant to ultraviolet degradation and biological and chemical environments normally found in soils.
  3. Minimum Average Roll Values:



**GENERAL SPECIFICATION 2741 ASPHALTIC CONCRETE PAVEMENTS**

---

<b>Property</b>	<b>Test Method</b>	<b>Units</b>	<b>Results</b>
Wide Width Tensile Strength	ASTM D4595	kN/m (lbs/in)	31x30.6 (175 x 175)
Grab Tensile Strength	ASTM D4632	N (lbs)	1335 x 1335
Grab Elongation	ASTM D4632	Percent	15 x 15
Puncture Strength	ASTM D4833	N (lbs)	555 (125)
Mullen Burst	ASTM D3786	KPa (psi)	4475 (650)
Trapezoidal Tear	ASTM D4533	N (lbs)	530 x 530
Apparent Opening Size	ASTM D4751	mm	0.212
Permittivity	ASTM D4491	sec-1	0.06
Water Flow Rate	ASTM D4491	l/min/m <sup>2</sup> (gpm/ft <sup>2</sup> )	200 (5)
UV Resistance (percent retained at 500 hours)	ASTM D4355	Percent	90

- B. Roads: Provide asphaltic concrete pavement for roadways conforming to the requirements specified in this Section and to the following standards:
1. Bottom Course: Broken stone, NYCDOT, Bureau of Highway Operations Standard Specifications, Section 2.02, Aggregate-Coarse, Type 1, Grade B, Sizes No. 1, No. 2 and No. 4. Provide bottom course consisting of a uniform mixture of broken stone, Size Nos. 1 and 2, and add No. 4 as a filler after the coarser mixture has been rolled and compacted.
  2. Tack Coat: Asphalt emulsion, NYSDOT Standard Specifications, material designation 702-90
  3. Binder Course: Binder mixture, NYSDOT Standard Specifications, Subsections 401-2.01 through 401.2.05, Table 401-1, Type 3
  4. Wearing Course: NYSDOT Standard Specifications, Subsections 401-2.01 through 401-2.05, Table 401-1, Type 6F
  5. Walks: Provide asphaltic pavement for walks conforming to the requirements specified in this section and to the following standards:
  6. Bottom Course: Asphaltic concrete mixture, NYSDOT Standard Specifications, Subsections 401-2.01 through 401-2.05, Table 401-1, Type 3

## GENERAL SPECIFICATION 2741 ASPHALTIC CONCRETE PAVEMENTS

---

7. Wearing Course: NYSDOT Standard Specifications, Subsections 401-2.01 through 401-2.05, Table 401-1, Type 6F
  8. Tack Coat: Asphalt emulsion, NYSDOT Standard Specifications, material designation 702-90
- C. Traffic and Parking Markings:
1. Color: As shown
  2. Conform to Fed. Spec. TT-P-115, Type III, quick drying, non-bleaching

### 2.03 QUALITY CONTROL OF GEOTEXTILE

- A. Manufacturing Quality Control: Testing shall be performed at a laboratory accredited by GAI-LAP for tests required for the geotextile, at frequency exceeding ASTM D 4354, with following minimum acceptable testing frequency:

Property	Test Method	Test Frequency sq m (sq ft)
Grab Tensile Strength	ASTM D4632	1/10,000 (100,000)
Grab Elongation	ASTM D4632	1/10,000 (100,000)
Trapezoidal Tear	ASTM D4533	1/10,000 (100,000)
Mullen Burst	ASTM D3786	1/10,000 (100,000)

- B. Conformance Testing:
1. Upon delivery to site, Engineer will remove samples of geotextile and send to laboratory for testing.
  2. Testing will be performed at a laboratory accredited by GAI-LAP in accordance with ASTM D4759, Practice A.

## PART 3 EXECUTION

### 3.01 ROADS

- A. General: Asphaltic concrete pavement roads shall consist of
1. A layer of woven geotextile fabric,
  2. A bottom course of broken stone,
  3. A tack coat of asphalt emulsion,
  4. An intermediate course of asphaltic concrete (close binder type),
  5. A tack coat of asphalt emulsion, and
  6. A wearing course of fine surface mix asphaltic concrete (top mix).

**B. Preparation of Subgrade:**

1. Remove to a depth of 24 inches, top soil, boulders, muck, soft clay, spongy material and any other objectionable material and replace them with broken stone, sand and gravel or other approved fill to promote positive drainage.
2. On sites where it appears that there may be some areas containing objectionable materials, proof roll to locate the unsuitable materials.
3. Exercise care during stripping operations to prevent excessive disturbance to subgrade. Use lightweight dozers or grade-alls for low strength, saturated, noncohesive and low cohesive soils.
4. For extremely soft ground such as peat bog areas, do not over excavate surface materials to take advantage of root mat strength.
5. If vegetation is present, cut at ground surface and place sawdust or sand over stumps and roots extending above ground surface.
6. Scrape and fill subgrades, as necessary, and thoroughly consolidate them to the required lines and grades. Consolidate subgrades for pavements by means of a smooth steel-wheel roller having a nominal gross weight of not less than 10 tons, and exerting a minimum force of not less than 300 pounds per inch of width on the compression roll faces, or approved equivalent.
7. Compact subgrade to not less than 75 percent relative density as determined by ASTM D4253, or not less than 95 percent of the maximum dry density as determined by ASTM D1557, as applicable.
8. In places where the use of a roller is impractical, compact subgrades with hand tampers weighing not less than 40 pounds and having a face not exceeding 80 square inches in area.
9. Subgrade shall be prepared not less than 100 feet in advance of the pavement to be immediately constructed.

**C. Installation of Geotextile:**

1. After subgrade has been prepared, place geotextile in same direction as the new roadway aggregate is being laid down.
2. Do not drag geotextile across subgrade. Place entire roll on subgrade surface and roll out smoothly. Remove wrinkles and folds by stretching and holding down with sandbags as required.
3. Join parallel rolls of geotextile as follows:

**GENERAL SPECIFICATION 2741 ASPHALTIC CONCRETE PAVEMENTS**

---

<b>California Bearing Ratio (CBR)</b>	<b>Method of Joining</b>
Over 2	300-450 mm (12-18 in) overlap
1-2	600-900 mm (24-36 in) overlap
0.5-1	900 mm (36 in) overlap or sewn
Less than 0.5	Sewn
All roll ends	900 mm (36 in) overlap or sewn

4. If the CBR of the subgrade is not known, join parallel rolls by sewing them together.
5. For subgrades with CBR less than or equal to 1, where the geotextile is to provide reinforcement, the geotextile shall be pretensioned in the following manner:
  - a. Proofroll with heavily loaded, rubber-tired vehicle. Wheel load of truck shall be equivalent to maximum expected for site. Vehicle to make at least four passes over first lift in each area of site.
  - b. Once design aggregate has been placed, use roadway prior to paving to prestress geotextile-aggregate system.
6. If required, the geotextile may be held in place prior to subbase placement with sandbags. The use of pins to anchor the geotextile will not be permitted, except at edges of existing pavement as specified below.
7. Do not place overlaps along anticipated primary wheel path locations. Place overlaps at end of rolls in direction of aggregate placement with previous roll on top.
8. When sewn seams are required, strength of seams shall be greater than or equal to 80 percent of tensile strength of unseamed geotextile as determined by same testing methods.
9. When placing woven geotextile on curves, fold or cut geotextile and overlap in direction of turn with previous fabric on top. Staple or pin folds in geotextile approximately 0.6 m (2 ft) on center.
10. When geotextile intersects an existing pavement area, extend geotextile to edge of old system and anchor it by trenching and covering the edge of the fabric with stone, or staple or pin the fabric to the ground. For widening or intersecting existing roads where geotextiles have been used, excavate edge of roadway down to existing geotextile and sew the

- new geotextile to the existing geotextile, or overlap and staple or pin the new fabric to the old and into the ground.
11. Prior to covering, inspect geotextile for excessive damage, including holes, rips and tears.
    - a. If excessive defects are observed, repair affected area by placing new layer of geotextile over damaged area.
    - b. Extend new layer beyond damaged area the same distance as required for overlap of adjacent rolls.
  12. End-dump base aggregate on previously placed aggregate. End dumping or tail-gate dumping of the aggregate directly on the geotextile will not be permitted.
    - a. For subgrades with CBR less than or equal to 1, limit pile heights to prevent possible subgrade failure.
    - b. Maximum placement thickness for subgrades with CBR less than or equal to 1 shall not exceed design thickness of road.
  13. Spread and grade first lift of aggregate to 300 mm (12 in) or to design thickness if less than 300 mm (12 in) prior to compaction. Do not allow traffic on soft roadway with less than 200 mm (8 in) of aggregate over geotextile, except 150 mm (6 in) for CBR greater than or equal to 3.
  14. Compact the bottom course as specified in Paragraph D.2. Vibratory compaction shall not be used on the initial lift over the geotextile.
  15. Perform construction parallel to road alignment.
  16. Fill ruts formed during construction to maintain adequate cover over geotextile. Do not blade ruts down.
  17. Place remaining base aggregate in lifts not exceeding 250 mm (10 in) in loose thickness and compact to specified density.
  18. Equipment may operate on roadway without aggregate for geotextile installation under permeable bases if subgrade is of sufficient strength.
    - a. For soils with CBR less than or equal to 0.5, use lightweight construction vehicles for access on first lift.
    - b. Limit construction vehicles in size and weight to limit rutting in initial lift to 75 mm (3 in).
    - c. If rut depths exceed 75 mm (3 in), decrease construction vehicle size or weight or increase lift thickness.
  19. Turning will not be permitted on first lift of base aggregate. Construct turn-outs at roadway edge to facilitate construction.

D. Bottom Course:

1. Spreading

- a. Spread the mixture of No. 1 and No. 2 broken stone uniformly on the geotextile with shovels from piles along the side of the roadway or from dumping boards or by means of vehicles of approved design constructed especially for this purpose, but in no case dump the material directly on the geotextile.
- b. The loose lift thickness shall be a minimum of 1.5 times the maximum particle size. The Contractor shall control the lift thickness, provided that the thickness shall not exceed the thickness limitations specified in Paragraph C, above, for installation of aggregate over geotextile, and shall not exceed the maximum allowed according to the equipment classifications in Subparagraph 2. *Compaction Equipment* of Subsection 203-3.03.C, *Compaction*, of New York State Department of Transportation Standard Specifications, and the equipment meets all specified class criteria of that Standard.
- c. Spread broken stone in sufficient quantity to provide the required thickness after rolling. The depth of stone shall be gauged by the use of cubical concrete blocks of the required thickness, or other approved means.
- d. Remove all segregated fine or coarse stone and replace it with well graded stone.
- e. Do not spread the broken stone over wet geotextile.
- f. Do not place broken stone adjacent to manhole heads or other structures until such structures have been set to the required lines and grades.

2. Rolling and Filling

- a. After the No. 1 and No. 2 stone mixture has been laid loose, thoroughly roll it with an approved smooth steel-wheel roller having a nominal gross weight of not less than 10 tons and exerting a minimum force of 300 pounds per inch of width on the compression roll faces.
- b. Start rolling longitudinally at the sides and proceed toward the center, overlapping on successive trips by at least one-half the width of a rear wheel. A minimum of 8 passes shall be applied over each lift with the roller operating at a speed not exceeding 6 feet per second. Rolling shall be continued until there is no movement of the stone ahead of the roller.

- c. After the bottom course is thoroughly compacted, as measured by the method described in Paragraph f, below, uniformly spread No. 4 stone over the compacted area from piles along the side of the roadway or from dumping boards. Broom the filler in and roll it dry until no more filler can be forced into the voids. Remove excess filler.
- d. Do not lay over 500 lineal feet of the bottom course without it being rolled and thoroughly filled.
- e. The maximum layer thickness prior to compaction shall be 300 mm (12 in.) as specified in Paragraph 3.01C, and the final compacted thickness shall be as shown on the Contract Drawings. In confined areas as defined by the Engineer the maximum compacted layer thickness shall be 6 inches.
- f. Do not allow the surface of the completed bottom course to deviate more than one-quarter inch in five feet from the nearest point of contact nor more than 3/8-inch in eighteen feet when tested by means of an eighteen foot straight-edge placed parallel to the centerline of the roadway.
- g. If any irregularities develop in the surface during or after rolling of the bottom course, remedy them by loosening the surface and removing or adding broken stone as may be required, and follow by rolling the entire area, including the surrounding surface, applying filler and continuing rolling until the course is compacted satisfactorily to a uniform surface.

E. Tack Coat:

- 1. Before spreading the binder course, spray the bottom course with an asphalt emulsion tack coat in the amount of 0.25 gallon per square yard. Allow the tack coat to cure until sticky or tacky. Renew and repair or replace damaged coating.
- 2. Tack coat shall be applied evenly by means of a truck having appropriate spray nozzles. All nozzles shall be kept free of clogs.
- 3. Paint contact surfaces of all curbing, gutters, manholes and adjacent pavement edges with the tack coat material.
- 4. Tack coat shall not be applied on a wet pavement surface or when the temperature is below 45°F.

F. Binder Course:

- 1. Preparation: Clean the bottom course of all dirt and loose material, thoroughly dry it and obtain the Engineer=s approval before laying the binder course.

## GENERAL SPECIFICATION 2741 ASPHALTIC CONCRETE PAVEMENTS

---

2. Weather Limitations: Bituminous material or mixture shall not be applied on any soft surfaces, when the surface is wet, when the temperature of the surface on which the mixture is to be placed is below 45°F, or when other weather conditions would prevent proper construction of the pavement.
3. Forms: When side forms are required, accurately set them to line and grade and securely stake and brace them in place sufficiently to withstand all construction operations. Thoroughly clean and oil forms before use.
4. Spreading:
  - a. Dump the binder course into the hopper of the spreader. Spread and screed it immediately to the full width required for the pavement and to such a depth that, when rolled, the required thickness is obtained. The maximum allowable compacted thickness shall be 4 inches.
  - b. When the mixture is to be spread by hand, dump it on approved steel dump sheets outside of the area on which it is to be spread and immediately distribute it into place and spread it in a uniformly loose layer.
  - c. Remove material from areas which show an excess or lack of bituminous material or an inconsistent mix and fill with new material. Re-spread or otherwise rectify areas which show segregation to obtain a uniform mixture in the course.
  - d. Do not use mixture which has been over 45 minutes out of the mixer, or if longer, the mixture must be over 250°F when spread.
  - e. Do not lay over 500 lineal feet of binder material without it being rolled and properly compacted.
5. Compacting:
  - a. Rake the mixture after spreading and immediately compress it thoroughly and uniformly by either of the following methods:
    - 1) Option A - Three-roller Compaction Train: Under this option, the binder course shall be initially rolled with an approved steel-wheel roller. The roller shall overlap the previous roller pass by one-half the width of the roller.
      - a) Immediately following the initial rolling, the course shall be rolled with an approved pneumatic rubber-tired roller. A minimum of three passes of the rubber-tired roller shall be made. One pass is defined as one movement of



the roller over any point of the pavement in either direction.

- b) Immediately following the intermediate rolling, the course shall be finish rolled with a steel-wheel tandem roller. This final rolling shall be both longitudinal and diagonal as directed by the Engineer and shall remove all shallow ruts and ridges and other irregularities from the surface. Rolling shall be continued until all roller marks are eliminated.
  - c) Under this option, the course shall not be compacted to a thickness in excess of 4 inches. No rollers shall move at speeds in excess of 3 miles per hour unless otherwise approved.
- 2) Option B - Vibratory Compaction: Under this option, the Contractor shall use vibratory compaction equipment appearing on the current Approved List - Bituminous Concrete Vibratory Compaction Equipment in the NYSDOT Standard Specifications. The Contractor may substitute one vibratory roller in lieu of the initial roller and the pneumatic roller in the conventional three-roller compaction train stipulated under Option A. Under this option, the course shall be finish rolled with a steel-wheel tandem roller having a minimum weight of 8 tons. This finish roller shall add a minimum of two passes closely following the vibratory roller or as directed by the Engineer.
- a) One vibratory roller and one steel-wheel tandem roller shall be provided for each nominal 12-foot width of paving. Dual vibrating drum rollers meeting the requirements of a steel-wheel tandem roller and operating in the static mode may be used as the finish roller. However, this single vibratory roller shall not be used as both the initial roller and the finish roller.
  - b. To prevent adhesion of the mixture to the roller, keep the drum properly moistened with water. Drums must have working water spray nozzles to keep drums moistened.
  - c. Compact material thoroughly with hot irons or damp vibratory tampers along curbs, headers, manholes and similar structures and at all places not accessible to the roller.

## GENERAL SPECIFICATION 2741 ASPHALTIC CONCRETE PAVEMENTS

---

- d. Remedy depressions which develop before the completion of the rolling by loosening the laid mixture and adding new mixture to bring such depressions to a true surface. Should any depressions remain after the final compaction has been obtained, remove the full depth of the mixture, replace it with new mixture, and reroll it to form a true and even surface. Correct all high spots, waves, bunches and honeycombing, to the satisfaction of the Engineer.
- e. Remove and replace with new material areas that are unbonded after rolling, areas containing drippings, areas that are fat or lean, and areas evidencing defective construction of any description.
- f. Do not allow the surface of the completed binder course to deviate more than 1/16 inch per foot from the nearest point of contact nor more than 1/4 inch maximum when tested longitudinally with an 18-foot straight edge placed parallel to the centerline of the roadway.
- g. After final compression, the finished course shall at no point have a density less than 95 percent, as measured by a nuclear density meter, of the laboratory compacted density.

### G. Wearing Course:

- 1. Preparation:
  - a. Thoroughly clean the binder course of all loose and foreign material before the top mixture is delivered.
  - b. Apply a tack coat at a rate of 0.03 to 0.07 gallon per square yard as approved by the Engineer.
  - c. Do not lay mixture until the Engineer approves the binder course and determines in all cases whether the weather conditions are suitable to permit laying.
- 2. Weather Limitations: Bituminous material or mixture shall not be applied on any soft surfaces, when the surface is wet, when the temperature of the surface on which the mixture is to be placed is below 45°F, or when other weather conditions would prevent proper construction of the pavement
- 3. Forms: If at the time of laying the mixture, permanent side supports such as curbs, edgings or gutters have not been constructed, firmly fasten in place suitable side forms of wood or steel, true to line and grade. In all cases adequately support the sides of roadways until final compaction has been obtained and the mixture has hardened by cooling.

4. Spreading and Compacting:
  - a. Spread and compact the wearing course until it meets the compaction and surface requirements specified above for the binder course.
  - b. The Contractor shall have the same options for achieving the required compaction as given for the compaction of the binder course.
  - c. Do not lay over 500 lineal feet of wearing course material without it being rolled and properly compacted.
  - d. Do not use mixture which has been over 45 minutes out of the mixer, or if longer, the mixture must be over 250°F when spread.
5. Joints: Perform construction as near continuously as possible. Carefully make joints between old and new pavements, or between successive days' work, in a manner which will insure a thorough and continuous bond, as follows:
  - a. Cut back the edge of the old surface before recommencing the operation of laying, in order to present a fresh, clean surface for contact with the newly placed material.
  - b. Carefully employ hot smoothing irons to heat the old pavement sufficiently (without burning) to insure a proper bond.
6. Shoulders: If temporary forms are used, protect the edges of the finished roadway by placing and thoroughly compacting approved material to form shoulders along the roadway as shown on the Contract Drawings. Construct finished shoulders 1/4 inch above the elevation of the finished roadway edges.
7. If weather conditions necessitate delaying the installation of the wearing course for more than two days, the tack coat shall be reapplied to the binder course at the rate of 0.03 to 0.07 gallon per square yard as approved by the Engineer.

3.02 WALKS

- A. General: Asphaltic concrete pavement walks shall consist of
  1. A bottom course of asphaltic concrete (close binder type),
  2. A tack coat of asphalt emulsion, and
  3. A wearing course of fine surface mix asphaltic concrete.
- B. Bottom Course:
  1. Before the bottom course is laid, compact the subgrade thoroughly, so that the bottom course, after compaction, will be found satisfactory

## GENERAL SPECIFICATION 2741 ASPHALTIC CONCRETE PAVEMENTS

---

when tested by the method given in Paragraph 4, below, and clean it of all loose and foreign material, dry it, and obtain the Engineer's approval.

2. Paint contact surfaces of all curbing, gutters, manholes and adjacent pavement edges with an asphalt emulsion tack coat at the rate of 0.03 to 0.07 gallon per square yard as approved by the Engineer.
3. Set forms, spread and compact the bottom course as specified above for the binder course for roads.
4. Provide a bottom course surface free from depressions exceeding 3/8-inch when tested with a 10-foot straight edge placed parallel with the center line of the walk.

### C. Wearing Course:

1. Clean the bottom course of all loose and foreign material before the wearing course mixture is delivered. Do not lay mixture until the Engineer approves the bottom course and determines in all cases whether the weather conditions are suitable to permit laying.
2. If at the time of laying the mixture, permanent side supports such as curbs, edging or gutters have not been constructed, fasten in place suitable side forms of wood or steel, true to line and grade. In all cases, adequately support the sides of walks until final compaction is obtained and until the mixture hardens.
3. Spread and compact the wearing course as specified for the bottom course.
4. Provide a walk surface free from depressions exceeding 1/8-inch when measured with a 10-foot straight edge placed parallel with the centerline of the walk.
5. Perform construction as near continuously as possible. Carefully make joints between old and new pavements, or between successive days' work, in a manner which will insure a thorough and continuous bond, as follows:
  - a. Cut back the edge of the old surface before recommencing the operation of laying, in order to present a fresh, clean surface for contact with the newly placed material.
  - b. Carefully employ hot smoothing irons to heat the old pavement sufficiently (without burning) to insure a proper bond.
6. Paving procedure, including compaction requirements, shall be the same as specified above for the wearing course for roads.

## GENERAL SPECIFICATION 2741 ASPHALTIC CONCRETE PAVEMENTS

---

### 3.03 PAVEMENT SAMPLES

- A. When required by the Engineer, furnish 4-inch diameter test samples cored from the binder course and from the completed pavement. The Engineer will choose the number of cores and the locations at which the cores shall be taken. Sample cores, when required, shall be taken for every 10,000 square feet of pavement and patch. Density test shall show that the sample is within 90 percent of the laboratory specimen. Replace with new mixture and refinish the areas of pavement so removed without additional compensation.

### 3.04 PATCHING

- A. As directed by Engineer, remove and replace defective areas. Cut such areas and replace with fresh asphaltic concrete and compact to required density.

### 3.05 CLEANING AND PROTECTION

- A. After paving, clear surfaces of excess asphaltic concrete and all foreign matter.
- B. Protect new pavement until fully hardened.
- C. Cover openings of drainage structures until permanent covers are placed.

### 3.06 PAVEMENT MARKING

- A. Clean with power and hand brooms.
- B. Mark edges straight and uniform. Use two coats and comply with manufacturer's recommendations.

END OF SECTION

NO TEXT ON THIS PAGE

**GENERAL SPECIFICATION 02771 CONCRETE CURBS, HEADERS AND  
SIDEWALKS**

---

**SECTION 02771  
Concrete Curbs, Headers and Sidewalks**

**PART 1 GENERAL**

**1.01 SECTION INCLUDES**

- A. The Contractor shall provide all labor, materials, and equipment required to provide concrete curbs, headers, and sidewalks, as shown, specified and required.
- B. The following index of this Section is included for convenience:

<u>Article</u>	<u>Title</u>	<u>Page</u>
		02771-
PART 1	GENERAL .....	1
1.01	Section Includes .....	1
1.02	Payment.....	1
1.03	Related Sections.....	1
1.04	References.....	2
1.05	Design Requirements .....	2
1.06	Submittals .....	2
PART 2	PRODUCTS.....	3
2.01	Materials .....	3
2.02	Source Quality Control .....	3
PART 3	EXECUTION.....	3
3.01	Sidewalk Installation.....	3
3.02	Curb And Header Installation .....	5

**1.02 PAYMENT**

- A. Unless otherwise provided in the Detailed Specifications, no separate payment will be made for performing any Work required under this Section and the Contactor shall include all costs thereof in its lump sum price bid for the Contract.

**1.03 RELATED SECTIONS**

- A. General Specification 02316 - Excavation
- B. General Specification 02317 - Backfilling
- C. General Specification 03100 - Concrete Formwork
- D. General Specification 03300 - Cast-in-Place Concrete
- E. General Specification 03350 - Concrete Finishes

## GENERAL SPECIFICATION 02771 CONCRETE CURBS, HEADERS AND SIDEWALKS

---

- F. General Specification 05501 - Metal Fabrications
- G. General Specification 09900 - Painting

### 1.04 REFERENCES

- A. ASTM A36 - Carbon Structural Steel
- B. New York City Department of Transportation (NYCDOT) Standard Highway Specifications (NYCDOT Specifications)
- C. NYCDOT Standard Details of Construction
- D. NYCDOT Street Design Manual

### 1.05 DESIGN REQUIREMENTS

- A. Concrete curbs, headers, and sidewalks which are outside the building line of the site and under jurisdiction of other City agencies, even though constructed as part of this Contract, shall be constructed in accordance with the Rules and Regulations, Standard Details and Standard Specifications of the governing agency in effect at the time of the award of this Contract and as further defined in the Contract Drawings and Detailed Specifications.
- B. Unless otherwise defined in the Contract Drawings or Detailed Specifications, concrete for curbs, headers, and sidewalks which are inside the building line of the site and not under the jurisdiction of other City agencies shall meet the following requirements:
  - 1. 3500 psi minimum 28-day compressive strength.
  - 2. Utilize type II Cement and contain aggregate conforming to ASTM #57.
  - 3. Water-cement ratio not exceeding 0.44 for normal weight structural concrete.
  - 4. Slump values of 1-1/2 inch minimum to 4 inch maximum.
  - 5. Desired air-entrainment of 6.5%, with an allowable range of +/- 1.5%.
  - 6. Concrete shall be proportioned, mixed, placed, cured and protected in accordance with the requirements of General Specification 03300 Cast-in-Place Concrete.

### 1.06 SUBMITTALS

- A. The Contractor shall submit Shop Drawings and material specifications for the approval of the Engineer. Submittals shall include, but not be limited to:
  - 1. Those required in General Specification 03300 - Cast-in-Place Concrete.
  - 2. Marked-up drawings and shop drawings including shop and field test reports of concrete samples tested in an approved laboratory.



**GENERAL SPECIFICATION 02771 CONCRETE CURBS, HEADERS AND  
SIDEWALKS**

---

3. Concrete sidewalk and curb layouts showing scoring and joint layouts, including joint and sealant materials to be incorporated.

**PART 2 PRODUCTS**

**2.01 MATERIALS**

- A. Coarse aggregate, unless otherwise specified, shall conform to the requirements of General Specification 03300 - Cast-in-Place Concrete.
- B. Concrete shall be air-entrained in accordance with General Specification 03300 - Cast-in-Place Concrete.
- C. Material for foundation of curbs, headers, and sidewalks shall consist Size No. 3 broken stone or gravel complying with the requirements of Section 2.02, NYCDOT Specifications, 100 percent of which passes a 2-1/2-inch square sieve; or other approved broken concrete, 100 percent of which passes a 2-1/2-inch square sieve; or other approved granular material containing not more than 5 percent material passing a No. 200 mesh sieve and not more than 5 percent retained on a 2-inch square sieve.
- D. Unless otherwise required by the Detailed Specifications, preformed expansion joint filler shall be Type IV as described in Section 2.15 of the NYCDOT Specifications.
- E. Joint sealing compound for horizontal joints shall be Type 2 cold application sealer as described in Section 2.22 of the NYCDOT Specifications.
- F. Structural steel shall be ASTM A36 and General Specification 05501 – Metal Fabrications.

**2.02 SOURCE QUALITY CONTROL**

- A. Concrete shall be tested and evaluated for strength and acceptance in accordance with the requirements of General Specification 03300 Cast-in-Place Concrete.

**PART 3 EXECUTION**

**3.01 SIDEWALK INSTALLATION**

- A. Concrete sidewalk shall be of the width shown or otherwise specified and shall be laid on 6 inches thick compacted broken stone base, unless otherwise specified or shown on the Contract Drawings.
- B. Sidewalk shall consist of a single course of concrete 4 inches thick, unless otherwise shown on the Contract Drawings.
- C. Concrete shall be pigmented when required by the Detailed Specifications.
- D. Excavation and subgrade preparation shall be in accordance with the requirements of General Specification 02316 - Excavation. All existing

## GENERAL SPECIFICATION 02771 CONCRETE CURBS, HEADERS AND SIDEWALKS

---

- material within the required 6 inches of foundation shall be removed in its entirety. Additional depth of foundation material for special conditions shall be placed as required by the Engineer.
- E. Materials: Foundation material shall be placed on the prepared subgrade and thoroughly compacted into a course not less than 6 inches thick. The top surface shall be parallel to the finished grade and at a distance below the grade equal to the specified thickness of concrete.
  - F. Forms: Forms shall be in accordance with General Specification 03100 – Concrete Formwork.
  - G. Slabs: Concrete sidewalk shall be built in approximately 20-foot lengths between expansion joints. The sidewalk shall be separated from adjoining structures by expansion joints. When directed, these joints shall be filled with dry sand. Expansion joints in sidewalk shall coincide with expansion joints in curb. Tooled control joints not less than 1/2 inch in depth shall be provided where at four-foot intervals unless otherwise shown on the Contract Drawings.
  - H. Expansion Joints: Transverse expansion joints shall be 1/2 inch in width and shall be filled with preformed joint filler to within 1 inch of the sidewalk surface. The top 1 inch shall be sealed with Type 2 cold application sealer complying with the requirements of Section 2.22 of the NYCDOT Specifications.
  - I. The foundation material shall be wetted immediately before concrete is placed. The concrete shall be placed within the forms and thoroughly tamped until the surface is at the finished grade.
  - J. When specified in the Detailed Specifications, the concrete sidewalk shall be pigmented with a minimum of 2 pounds of dispersed carbon black per bag of cement to produce a bluestone color. Either the coloring pigment shall be treated so as not to cause an increase or decrease of the entrained air content in cement mortar or in the concrete of more than 10 percent, or the amount of air-entrainment agent added to the concrete shall be adjusted to meet the specified requirements. All cement used for concrete work specified herein shall be of uniform color. Requirements for other colors are covered in the Detailed Specifications.
  - K. The top surfaces shall be finished in accordance with General Specification 03350 – Concrete Finishes. Each rectangular slab shall have all edges neatly rounded with proper tools and be bounded on all sides by a troweled border about 1 inch in width. Surface texture of pedestrian ramps shall be transverse grooves, 1/2 inch wide by 1/4 inch deep on 2-inch centers.
  - L. Backfilling shall follow the removal of forms as soon as practicable and, unless otherwise permitted, shall be of clean earth, satisfactorily compacted.

## GENERAL SPECIFICATION 02771 CONCRETE CURBS, HEADERS AND SIDEWALKS

---

Backfilling shall conforming to the requirements of General Specification 02317 - Backfilling.

- M. Concrete sidewalk shall be cured according to General Specification 03300 Cast-in-Place Concrete.
  - N. All material types of sidewalk, such as unpigmented, pigmented, bluestone or pavers, and details are outlined in the NYCDOT Street Design Manual.
- 3.02 CURB AND HEADER INSTALLATION
- A. Concrete curbs, headers, and steel faced concrete curbs, except as otherwise detailed and specified, shall be constructed in accordance with the applicable provisions of Sections 4.08 and 4.09, NYCDOT Standard Highway Specifications, except that concrete strength shall conform to Class 25 as indicated in General Specification 03300 Cast-in-Place Concrete. Depressed curbs shall be provided where specified or shown on the Contract Drawings.
  - B. Steel street curbs shall conform to ASTM A36 of the size indicated on the Contract Drawings. The length of straight runs shall be not less than 10 feet nor more than 20 feet. Curved curb angles shall be bent to the radius indicated, and provided with a straight tangent at each end, 3 feet in length. Special steel curb angles of approved type shall be provided at drop curbs. Where the length of the special drop curb exceeds 20 feet, it shall be spliced with an approved type butt welded joint. Anchors shall be welded to all steel curbing. The steel curbs shall be placed within the forms, upon suitable chairs, to the proper lines and grades. The joints between units of curbing shall be 1/8 inch. All surfaces of steel curbing, including anchors, shall be thoroughly cleaned of all rust, oil, grease, scale or other foreign matter before concrete is placed. All surfaces of steel curbing which are to remain exposed in the finished work shall be painted in the shop in accordance with General Specification 09900 - Painting. Finish coats shall be gray in color.
  - C. Granite and bluestone street curbs and headers shall be Class A dressed curbs and headers conforming to the requirements of Section 2.12 of the NYCDOT Standard Highway Specifications. When specified, a concrete cradle shall be used conforming to the provisions of Section 4.07 of the NYCDOT Standard Highway Specifications, except that concrete strength shall conform to Class 25 as indicated in General Specification 03300 Cast-in-Place Concrete.

END OF SECTION

**GENERAL SPECIFICATION 02771 CONCRETE CURBS, HEADERS AND  
SIDEWALKS**

---

NO TEXT ON THIS PAGE

**SECTION 02821  
Metal Fence**

**PART 1 GENERAL**

**1.01 SUMMARY**

- A. This Section describes the requirements for metal fencing. Metal fencing shall be as specified herein and in the Detailed Specifications and as shown on the Contract Drawings. The fence shall be all metal, constructed of wire fabric fastened to top, bottom and intermediate horizontal rails and to vertical line posts, corner posts and terminal posts and shall include all system components such as gates, fittings, fastenings and other accessories with polymer coating and other protective coatings as specified.
- B. Unless otherwise shown or specified, all metal fencing shall be furnished and installed as specified. It is the intent that the Detailed Specifications will include any variations necessary for specific applications.
- C. The Contractor shall implement practices and procedures to meet the project's sustainability goals as identified in the Contract Documents. The Contractor shall ensure that the sustainability requirements of this Section are implemented to the fullest extent.
- D. The following index of this Section is presented for convenience:

<u>Article</u>	<u>Title</u>	<u>Page</u>
		02821-
PART 1	GENERAL.....	1
1.01	Summary.....	1
1.02	Payment.....	2
1.03	Related Sections.....	2
1.04	References.....	2
1.05	System Design Requirements .....	3
1.06	Quality Assurance.....	4
1.07	Submittals .....	5
1.08	Delivery, Storage And Handling.....	7
1.09	Project Conditions.....	7
PART 2	PRODUCTS.....	7
2.01	Manufacturers .....	7
2.02	Materials .....	7
2.03	Fabrication .....	11

**GENERAL SPECIFICATION 02821 METAL FENCE**

---

PART 3	EXECUTION.....	12
3.01	Installation.....	12
3.02	Adjustment.....	15
1.02	PAYMENT	
A.	Unless otherwise provided in the Detailed Specifications, no separate payment will be made for performing any Work required under this Section and the Contractor shall include all costs thereof in its lump sum price bid for the Contract.	
1.03	RELATED SECTIONS	
A.	General Specification 03300	- Cast-in-Place Concrete
B.	General Specification 05081	- Galvanizing
1.04	REFERENCES	
A.	ASTM A53	- Pipe, Steel, Black and Hot-Dipped, Zinc-Coated Welded and Seamless, Standard Specification for
B.	ASTM A90	- Weight [Mass] of Coating on Iron and Steel Articles with Zinc or Zinc-Alloy Coatings, Standard Test Method for
C.	ASTM A121	- Metallic-Coated Carbon Steel Barbed Wire, Standard Specification for
D.	ASTM A123	- Zinc (Hot-Dip Galvanized) Coatings on Iron and Steel Products, Standard Specification for
E.	ASTM A653	- Steel Sheet, Zinc-Coated (Galvanized) or Zinc-Iron Alloy-Coated (Galvannealed) by the Hot-Dip Process, Standard Specification for
F.	ASTM A817	- Metallic-Coated Steel Wire for Chain-Link Fence Fabric and Marcellled Tension Wire, Standard Specification for
G.	ASTM A824	- Metallic-Coated Steel Marcellled Tension Wire for Use with Chain

## GENERAL SPECIFICATION 02821 METAL FENCE

---

- Link Fence, Standard Specification for
- H. ASTM A1011 - Steel, Sheet and Strip, Hot-Rolled, Carbon, Structural, High-Strength Low-Alloy, High-Strength Low-Alloy with Improved Formability, and Ultra-High Strength, Standard Specification for
- I. ASTM B6 - Zinc, Standard Specification for
- J. ASTM F567 - Installation of Chain-Link Fence, Standard Practice for
- K. ASTM F626 - Fence Fittings, Standard Specification for
- L. ASTM F900 - Industrial and Commercial Swing Gates, Standard Specification for
- M. ASTM F1043 - Strength and Protective Coatings on Steel Industrial Chain Link Fence Framework, Standard Specification for
- N. ASTM F1083 - Pipe, Steel, Hot-Dipped Zinc-Coated (Galvanized) Welded, for Fence Structures, Standard Specification for
- O. ASTM F1184 - Industrial and Commercial Horizontal Slide Gates, Standard Specification for
- P. CLF-PM0610 - Chain Link Fence Manufacturers Institute: Product Manual

### 1.05 SYSTEM DESIGN REQUIREMENTS

- A. Comply with the standards of the Chain Link Fence Manufacturers Institute for product and installation requirements and the requirements of ASTM F567. These standards shall represent a minimum level of quality when additional information is not shown or specified in the Contract Documents.
- B. The fabricator shall be responsible for providing structural calculations for the metal fence system to Contractor for submittal to Engineer as part of Shop Drawing review. Structural analysis shall verify that all system components including, but not limited to, supports, gates,

## GENERAL SPECIFICATION 02821 METAL FENCE

---

fasteners, fittings and connections meet the requirements of the New York City Building Code.

- C. Member sizes, thicknesses and weights shown or specified shall be considered minimum. Where structural analysis indicates the need for additional members or increased member size, thickness or weight, these shall be provided at no additional expense to the City.
- D. Modifications may be made only as necessary to meet field conditions to ensure proper fitting and support of the Work and only upon submittal of Shop Drawing and receipt of approval by Engineer.
- E. Sustainable Design Requirements
  - 1. Recycled Content of Metal Fence: Postconsumer recycled content plus one-half of preconsumer recycled content not less than 25 percent.
- F. Project-specific system design requirements will be provided in the Detailed Specifications, if necessary, to supplement requirements given herein or in the Contract Drawings.

### 1.06 QUALITY ASSURANCE

- A. Installer Qualifications:
  - 1. Contractor shall select a single installer regularly engaged in the installation of metal fencing with successful experience in the erection of the type of metal fencing specified. Installer shall agree to employ only tradesmen with specific skill and experience in the erection of this type of work.
  - 2. Contractor shall submit the name and experience record of the installer to Engineer along with the names and telephone numbers of owners, architects or engineers responsible for the project and the approximate contract cost of the metal fencing and the amount of area installed.
  - 3. Contractor shall submit evidence of approval of the installer by the metal fence manufacturer. Installers who have not had the type of experience required to perform the kinds of work required will not be approved.
- B. Source Quality Control:
  - 1. Provide metal fencing system as a complete system with all gates, hardware, appurtenances and other components produced by a single manufacturer, including custom erection accessories, fittings, clamps and fastenings as may be necessary or required.



## GENERAL SPECIFICATION 02821 METAL FENCE

---

2. Provide fence fabric imprinted with the manufacturer's trade name, country of origin, core wire gauge, and finished outside diameter gauge. Material delivered to the Project site lacking this information will be rejected for use in the work and shall be immediately removed even if discovered after being incorporated in the work, at no additional expense to the City.
3. Provide shipping list for materials used, endorsed with the manufacturer's voucher certifying that the material used in the metal fencing system complies with these Specifications.
4. Structural shapes of satisfactory sections and equal strengths may be substituted if approved by Engineer.

### 1.07 SUBMITTALS

- A. The Contractor shall submit Shop Drawings and material specifications for the approval of the Engineer. Submittal shall include, but not be limited to:
  1. Each component, fastener, post, rail, support, chain link fabric and other items labeled as to the use and location in the work.
  2. Samples approximately 6 inches long, and 6 inches square of all chain link fence fabric materials including framework members, and typical accessories. Engineer's review will be for workmanship only. Compliance with all other requirements is the responsibility of Contractor.
- B. Shop Drawings: Submit for approval the following:
  1. Copies of manufacturer's technical product information, specifications and certified test reports on physical properties, and installation instructions for all metal fencing system components.
  2. All structural calculations verifying that all system components comply with the requirements of the New York City Building Code.
  3. Large-scale details drawn at a scale of 3 inches to the foot for all connections and gate details. Drawings at a scale of 1/4 inch equals 1 foot of typical metal fence assembly identifying all components, metal fence heights, locations, and sizes and weights of all rails, posts, braces, supports and footings.
  4. A list of all hardware and accessories.

## GENERAL SPECIFICATION 02821 METAL FENCE

---

### C. Sample Mock-Ups

1. Materials for the work and full size sample mock-up shall be as shown on the Contract Drawings and as specified herein.
2. Contractor, his fabricator and installer shall build a full size sample mock-up at the Project site demonstrating to Engineer the ability to match the quality of workmanship, methods of detailing, and tolerances shown on the Contract Drawings and as specified herein. Once approved, the sample mock-up shall serve as a standard for all metal fence installation work required under the Contract.
3. Full size sample mock-ups that, in the opinion of Engineer, do not adequately demonstrate the ability of the installer to provide the requirements specified will not be approved and Contractor shall proceed to propose an alternative installer to Engineer for approval.
4. Cost of all full size sample mock-ups shall be at the expense of Contractor.
5. Each fabricator and installer proposed by Contractor shall be permitted to build two full size sample mock-ups using approved components as required to obtain Engineer's approval. If after building two mock-ups, Engineer is still uncertain that the fabricator or installer is capable of matching the workmanship, methods of detailing and performance requirements specified, Contractor shall propose alternative fabricators and installers. Contractor will be required to continue this process until the work of an acceptable fabricator and installer is approved.
6. Full size sample mock-up shall not be altered, moved or destroyed until written permission is received from Engineer. Mock-ups destroyed before Contractor receives written permission shall be rebuilt at no additional expense to the City.

### D. Sustainable Design Submittals:

1. Environmental Materials Reporting Form (EMRF) Recycled Content. Provide the following information:
  - a. Name of Product and Manufacturer.
  - b. Material cost breakdowns. Cost breakdowns must include total material-only cost (excluding installation, labor and equipment).
  - c. The percentage (by weight) of post-consumer and pre-consumer recycled content for the submitted product.

## GENERAL SPECIFICATION 02821 METAL FENCE

---

### 1.08 DELIVERY, STORAGE AND HANDLING

- A. Delivery of Materials:
  - 1. Deliver materials in manufacturer's original, unopened packaging with all tags, labels and other identifying information intact and legible.
- B. Storage of Materials:
  - 1. Store all materials under weatherproof cover, off the ground and away from other construction activities. Do not store material in a manner which would create a humidity chamber. Provide for free movement of air under protective cover and between components of the metal fence system.
- C. Handling of Materials:
  - 1. Handle material in a manner that is in compliance with product institute standards and that will prevent damaging coatings.

### 1.09 PROJECT CONDITIONS

- A. Field Measurements: Take field measurements and verify layout information and dimensions for metal fencing and gates in relation to property surveys and existing conditions.
- B. Do not begin installation and erection of the metal fencing system until final grading is completed.

## PART 2 PRODUCTS

### 2.01 MANUFACTURERS

- A. Manufacturers will be listed, if necessary, in the Detailed Specifications.

### 2.02 MATERIALS

- A. General:
  - 1. All parts of the metal fence system shall be galvanized steel, except that chain link fence fabric shall be aluminum-coated steel and fittings may be galvanized malleable iron, or galvanized wrought iron.
  - 2. Wire gauges shall conform to American Steel and Wire Company gauge.
  - 3. Concrete for footings shall be Class 25 conforming to the requirements of General Specification 03300 – Cast-in-Place Concrete.
  - 4. Pipe sizes shall be commercial pipe sizes complying with ASTM F1083.

## GENERAL SPECIFICATION 02821 METAL FENCE

---

5. Tube sizes specified are nominal outside dimensions.
6. Roll-formed section sizes are the nominal outside dimensions.
7. Heat-form all arcs and chords before protective coatings are applied to metal.
8. All sizes specified are given for uncoated steel. All protective coatings are in addition to specified dimensions and sizes.
9. All galvanizing shall be done in accordance with General Specification 05081 - Galvanizing.

**B. Chain Link Fence Fabric:**

1. Fabric shall be in one-piece widths for fencing 12 feet - 0 inches and less in height to comply with Chain Link Fence Manufacturers Institute, Product Manual.
2. Wire mesh shall be woven throughout in the form of approximately uniform square mesh with parallel sides and horizontal and vertical diagonals of approximately uniform dimensions, of size and gauge as specified in the Detailed Specifications, ASTM A817, Type 1, cold-drawn carbon steel wire with minimum breaking strength of 2,170 pounds and coated with 0.40 ounces of aluminum by the hot-dip process per square foot of wire surface. The fabric shall be recommended by the Chain Link Fence Manufacturers Institute for heavy industrial usage.
3. Provide fabric knuckled on edges to prevent unraveling.

**C. Framework:**

1. General: The following table is provided for the convenience of Contractor and provides actual OD and equivalent nominal NPS size and trade size of round members. Pipe shall be commercial grade, plain end steel pipe with standard weight walls. Steel strip used in the manufacture of pipe shall be in compliance with ASTM F1083, Schedule 40 pipe with minimum yield strength of 25,000 psi and with 1.8 ounces of hot-dipped zinc coating per square foot of surface area. Type A coating shall be applied both inside and outside according to ASTM F1043, as determined by ASTM A90.

<b>Actual OD</b>	<b>NPS Size</b>	<b>Trade Size</b>
1.315	1	1-3/8
1.660	1-1/4	1-5/8

**GENERAL SPECIFICATION 02821 METAL FENCE**

---

<b>Actual OD</b>	<b>NPS Size</b>	<b>Trade Size</b>
1.900	1-1/2	2
2.375	2	2-1/2
2.875	2-1/2	3
3.500	3	3-1/2
4.000	3-1/2	4
6.625	6	6-5/8
8.625	8	8-5/8

2. For maximum metal fence system height of 8 feet - 0 inches provide posts, gate frames and rails shall be of the following nominal pipe sizes and minimum weights per linear foot:
    - a. Line Posts: 2-1/2 NPS @ 5.79 lbs per foot
    - b. End, Corner and Pull Posts: 3 NPS @ 7.58 lbs per foot
    - c. Gate Frames: 2 NPS @ 3.65 lbs per foot
    - d. Gate Posts:
      - 1) For single gates 6 ft. wide or less, or double gates 12 ft. wide or less: 3 NPS @ 7.58 lbs per foot.
      - 2) For single gates more than 6 ft. wide, or double gates more than 12 ft. wide: 4 NPS @ 10.79 lbs per foot.
    - e. Top Rails, Intermediate Rails, Bottom Rails and Braces: 1-1/2 NPS @ 2.72 lbs per foot.
  3. Provide manufacturer's longest length rails, with extra-long expansion sleeves making firm connections but permitting expansion and contraction for each joint. Provide means for attaching the top rail securely to each gate, corner, pull and terminal post.
- D. Roll-Formed Steel: Rolled steel shapes shall be produced from structural-quality steel conforming to ASTM A1011, Grade 45, or ASTM A446, Grade D, galvanized, with a minimum yield strength of 45,000 psi. Protective coating system shall conform to ASTM F1043, Type A, hot-dipped galvanizing with a minimum of 4.0 ounces of zinc per square foot of surface area in accordance with the requirements of ASTM A653.

## GENERAL SPECIFICATION 02821 METAL FENCE

---

- E. Fittings and Accessories: All fittings and accessories shall comply with ASTM F626.
1. Post Caps: Pressed steel, cast iron or cast aluminum alloy, fitting snugly over posts to exclude moisture; cone-type caps for terminal posts and loop-type caps for line posts.
  2. Rail and Brace Ends: Pressed steel, cast iron or cast aluminum alloy, cup-shaped to receive rail and brace ends.
  3. Rail Sleeves: Tubular steel, 0.051-inches thick by 7-inches long, expansion type.
  4. Tension Bars: Steel strip, 5/8-inch wide by 3/16-inches thick.
  5. Tension Wire: Marcellled 7 gauge steel wire with minimum coating of 0.40 ounces per square foot of wire surface in compliance with ASTM A824.
  6. Tension Bands: Pressed steel, 12 gauge thick by 3/4-inch wide.
  7. Truss Rods: Steel rod, 3/8-inch diameter merchant quality with turnbuckle.
  8. Barbed Wire Arms: Pressed steel, cast iron or cast aluminum alloy fitted with clips or slots for attaching three strands of barbed wire - arms set outward on a 45 degree angle, or vertical, and capable of supporting a 250 pound load at outer barbed wire connecting point without causing permanent deflection.
  9. Fence Latches:
    - a. Manufacturer's double latching bar latch devices with heavy mil polyvinyl chloride coating.
    - b. Padlock eye as integral part of latch.
  10. Keeper: Provide a gatekeeper for vehicle gates that automatically engages gate leaf and holds it in the open position until manually released.
  11. Gate Hinges: 180 degree offset heavy-industrial hinges; 1-1/2 pair per leaf.
  12. Tie Wire: Aluminum; 9 gauge, alloy 1100-H4; polyvinyl chloride coated to match fence fabric.
  13. Gate Stops: Provide gate stops for double gates consisting of mushroom-type flush plate with anchors, set in concrete, and designed to engage a center drop rod or plunger bar. A locking device and padlock eyes shall be included as integral parts of the

## GENERAL SPECIFICATION 02821 METAL FENCE

---

latch, permitting both gate leaves to be locked with a single padlock.

- F. Gates:
  - 1. Swing gates shall comply with ASTM F900.
  - 2. Sliding gates shall comply with ASTM F1184.
- G. Hog Rings: Steel wire, 11 gauge, with a minimum zinc coating of 0.80 ounces per square foot of wire surface.
- H. Barbed Wire: Commercial quality steel, two strand twisted, 12-1/2 gauge line wire with 14 gauge four point barbs at 5-inch spacing - coating shall consist of 0.40 ounces of aluminum per square foot of wire surface in compliance with ASTM A121.
- I. Galvanizing: Zinc for galvanizing shall be of High Grade or Special High Grade conforming to ASTM B6 with a maximum aluminum content of 0.01 percent. Material shall be galvanized by the "hot-dip" process in conformity with the following standards:

Class of Work	ASTM
Structural Iron and Steel Shapes	A123
Fittings and Accessories	F626
Pipe	A53

### 2.03 FABRICATION

- A. Fabrication Tolerances:
  - 1. Fabric, posts, rails, and other supports shall be straight or uniformly curved to provide the profiles shown on the Contract Drawings, to a dimensional tolerance of 1/16 inch in 10 feet - 0 inches without warp or rack in the finished installation.
- B. Fabrication shall be in compliance with ASTM F1083 for metal fencing, ASTM F1184 for horizontal slide gates, and ASTM F900 for swing gates.
- C. In addition to specified standards, fabrication shall be in compliance with Chain Link Fence Manufacturer's Institute Standard, CLF-PM0610 - Product Manual.
- D. Gates:
  - 1. Gate hinges shall be of the double clamping offset type. To hold the gate in the open or closed positions, each gate frame shall be

## GENERAL SPECIFICATION 02821 METAL FENCE

---

provided with a keeper which automatically engages a gate shoe set in concrete. Gates shall have a drop latch with provision for a padlock. Each gate shall be provided with a heavy-duty bronze padlock and shackle chain, No. 160DHM with 11/32-inch marine brass shackle as manufactured by:

- a. The Master Lock Company, Oak Creek, WI.
- b. Or approved equal.

And three keys for each padlock. Where more than one gate is required for the same enclosure, padlocks shall be keyed the same.

2. All gate frames shall have intermediate horizontal rails. Gate frames shall be of welded construction and shall be galvanized after fabrication. Single gates 6 feet wide or wider and double gates 12 feet wide or wider shall be provided with diagonal bracing in one direction, extending from top to bottom rail. The diagonal bracing shall be at least 1/2 inch in diameter and shall be provided with turnbuckles.

### PART 3 EXECUTION

#### 3.01 INSTALLATION

##### A. General:

1. Install metal fencing system in compliance with ASTM F567.
2. Apply fabric to outside of framework. Install fencing on boundary lines inside of property line established by survey.
3. Do not begin metal fence installation and erection before the final grading has been completed, and finish elevations have been established.

##### B. Excavation:

1. Drill or hand-excavate (using post-hole digger) holes for posts to diameters and spacings shown or specified, in firm, undisturbed or compacted soil.
2. Unless otherwise indicated, excavate hole depths approximately 6 inches lower than post bottom.
3. Spread soil from excavations uniformly adjacent to the fence line, or on adjacent areas of the Project site, as directed.
4. When solid rock is encountered near the surface, drill into rock at least 12 inches for line posts and at least 18 inches for end, pull, corner and gate posts. Drill hole at least 1 inch greater in



## GENERAL SPECIFICATION 02821 METAL FENCE

---

diameter than the largest dimension of the post to be placed. Remove rock cores from the Site.

5. If solid rock is below soil overburden, drill to full depth required, except penetration into rock need not exceed the minimum depths specified above.

### C. Setting Posts:

1. Remove loose and foreign materials from sides and bottoms of holes, and moisten soil prior to placing concrete.
2. Center and align posts in a continuous pour, and vibrate or tamp concrete for consolidation. Check each post for vertical and top alignment, and hold in position during placement and finishing operations.
3. Posts shall be set in concrete footings, except as otherwise shown or specified. Line posts shall extend at least 3 feet below finished grade, and gate posts shall extend at least four feet below finished grade. Concrete footings shall have a minimum diameter of 15 inches and shall extend at least 6 inches below the bottom of the posts. Tops of concrete footings shall receive a troweled finish. Top of footing shall be 2 inches above finish grade and sloped to direct water away from posts. The portion of posts embedded in concrete shall receive two coats of an approved coal tar paint before embedment.
4. Line posts shall be spaced not more than 10 feet on centers. Install caps on tops of all posts to exclude moisture and to receive the top rail unless equal protection is afforded by combination post top cap and barbed wire supporting arm, where barbed wire is required.
5. Keep exposed concrete surfaces moist for at least seven days after placement, or cure with membrane curing materials, or other acceptable curing method.
6. Grout posts when installed in sleeved holes, concrete constructions, and rock.
7. Allow concrete to attain at least 75 percent of its minimum 28-day compressive strength, but in no case sooner than seven days after placement, before rails, tension wire, or fabric is installed. Do not stretch and tension fabric or wires, and do not hang gates until the concrete has attained its full design strength.

## GENERAL SPECIFICATION 02821 METAL FENCE

---

- D. Chain Link Fence Fabric:
1. Pull fabric taut so that fabric remains in tension after force is released, with bottom edge 1 inch above grade. Fasten to terminal posts and gate posts with tension bars threaded through mesh and secured with tension bands at maximum intervals of 14 inches. Tie to line posts, gate frames and top and bottom rails with tie wires spaced at maximum 12 inches on posts and 24 inches on rails.
  2. The tension bars shall be connected to posts and frames by means of adjustable bolts and bands spaced not more than 14 inches apart.
- E. Top Rails, Intermediate Center Rails and Bracing:
1. Install top rails through line post caps, bending to radius for curved runs, connecting sections with sleeves to form a continuous rail between terminal posts.
  2. Install center rails only where shown or specified. Install center and bottom rails in one piece between posts and flush with the post on the fabric side, using rail ends and special offset fittings where necessary.
  3. Install brace assemblies at end posts and at both sides of corner and pull post panels. Panels adjacent to gates shall have intermediate horizontal rails and diagonal bracing. The diagonal bracing shall run from the center of the first line post to the bottom of the terminal post.
- F. Tie Wire: Use U-shaped wires conforming to diameter of pipe. Wire shall clasp pipe and fabric firmly, and each end of the wire shall be wrapped around the fabric at least two full turns and bent to minimize hazard to persons or clothing.
- G. Barbed Wire:
1. When barbed wire is shown or specified along the top of the fence, it shall be supported at the posts by arms inclined inward at an angle of 45 degrees.
  2. The vertical members of gates shall be extended to receive the barbed wire which shall be fastened securely to prevent movement or displacement.
- H. Fasteners: Install nuts for fittings, bands and hardware bolts on side of metal fence opposite fabric side. Peen ends of bolts or score threads to prevent removal of nuts.

## GENERAL SPECIFICATION 02821 METAL FENCE

---

### 3.02 ADJUSTMENT

- A. Gates: After repeated operation of completed installation equivalent to three days of use by normal traffic, readjust gates for optimum operation and safety.
- B. Lubricate operating equipment and clean exposed surfaces.
- C. Repair and replace all broken or bent components. Repair coatings damaged in the shop or during field erection by recoating with manufacturer's recommended repair compound, applied in accordance with manufacturer's directions.
- D. Protect metal fencing system from construction traffic and all other damage until acceptance of the work.

END OF SECTION

**GENERAL SPECIFICATION 02821 METAL FENCE**

---

NO TEXT ON THIS PAGE

**SECTION 02841  
Guide Railing**

**PART 1 GENERAL**

**1.01 SECTION INCLUDES**

- A. Requirements for furnishing and installing corrugated steel beam guide railing and concrete median barrier (Jersey barrier).
- B. The following index of this Section is presented for convenience:

<u>Article</u>	<u>Title</u>	<u>Page</u>
		02841-
PART 1	GENERAL .....	1
1.01	Section Includes .....	1
1.02	Payment.....	1
1.03	Related Sections.....	1
1.04	References.....	2
1.05	System Description .....	2
1.06	Submittals .....	2
PART 2	PRODUCTS.....	2
2.01	Manufacturers .....	2
2.02	Materials .....	2
2.03	Fabrication .....	3
2.04	Finishes .....	4
2.05	Source Quality Control .....	4
PART 3	EXECUTION.....	5
3.01	Installation.....	5
3.02	Field Quality Control .....	5

**1.02 PAYMENT**

- A. Unless otherwise provided in the Detailed Specifications, no separate payment will be made for performing any Work required under this Section and the Contractor shall include all costs thereof in its lump sum price bid for the Contract.

**1.03 RELATED SECTIONS**

- A. General Specification 03210 - Reinforcing Steel
- B. General Specification 03300 - Cast-in-Place Concrete
- C. General Specification 05081 - Galvanizing

## GENERAL SPECIFICATION 02841 GUIDE RAILING

---

### 1.04 REFERENCES

- A. New York City Department of Transportation (NYCDOT), Bureau of Highway Operations Standard Specifications
- B. New York State Department of Transportation (NYSDOT), Office of Engineering Standard Specifications
- C. NYSDOT Standard Sheet Nos. 606-8R1, 606-9R1 and 606-10R1
- D. ASTM A615 - Deformed and Plain Billet-Steel Bars for Concrete Reinforcement, Standard Specification for

### 1.05 SYSTEM DESCRIPTION

- A. Beam Type Guide Rails shall consist of steel rail elements affixed to and supported by structural steel beam posts. Except as otherwise shown on the Contract Drawings, specified, or directed by the Engineer, the material, manufacturer, fabrication and installation or erection of guide rails shall be in compliance with current New York State Department of Transportation (N.Y.S.-DOT) Standard Sheet Nos. 606-8R1, 606-9R1 and 606-10R1.
- B. Precast concrete barrier shall be fabricated to conform to the shapes and sizes shown on the Contract Drawings and, except as otherwise specified, shall conform to the requirements of the current NYSDOT Standard Specifications.

### 1.06 SUBMITTALS

- A. The Contractor shall submit Shop Drawings and material specifications for the approval of the Engineer. Submittals shall include, but not be limited to:
  - 1. The location of steel guide rails and precast concrete barriers.
  - 2. The form dimensions and location and type of reinforcement in the precast concrete barrier, and shall show the details and dimensioning of the beam guide rails, including location and spacing of steel posts.
  - 3. The test reports on concrete and reinforcing steel certified by an approved testing laboratory.

## PART 2 PRODUCTS

### 2.01 MANUFACTURERS

- A. Manufacturers will be listed, if necessary, in the Detailed Specifications.

### 2.02 MATERIALS

- A. Materials for beam type guide rails shall be as specified in NYSDOT Standard Specifications.
- B. Precast concrete barriers shall be constructed in accordance with the requirements of NYCDOT Standard specifications except that concrete and reinforcing steel shall conform to the requirements of General Specification

## GENERAL SPECIFICATION 02841 GUIDE RAILING

---

03210 – Reinforcing Steel. Concrete shall be Class 40, and reinforcing steel shall comply with ASTM A615, Grade 60.

### 2.03 FABRICATION

#### A. Steel Guide Rail:

1. Steel guide rails shall be of the Heavy Post Blocked-Out Corrugated Beam type as shown on the NYSDOT standard sheets.
2. Corrugated beam guide rails to be installed on curves of a radius equal to or less than 150 feet shall be shop curved as required by the NYSDOT Standard Specifications.

#### B. Precast Concrete Barrier:

1. The length of individual sections of precast concrete barrier shall not exceed 30 feet.
2. The tolerance on placement of reinforcing steel in the barrier shall be +1 inch. The chairs, spacers or other devices used to maintain the reinforcement in position shall have rust resistant tips so that no spots will show on the finished faces.
3. Concrete shall be consolidated in the forms by internal vibrators. Exposed surfaces shall be free from objectionable imperfections, such as honeycomb and air voids, as determined by the Engineer. If air voids collect at the interface of the concrete and forms, the forms shall be tapped on the outside with rubber mallets or similar devices to displace the entrapped air.
4. Curing:
  - a. The precast barrier sections may be cured by means of quilted covers which shall be kept wet, or by using polyethylene coated burlap blankets which will not require wetting. Polyethylene coated blankets shall be laid dry with the burlap side against the concrete, and adjoining blankets shall be lapped sufficiently to provide a moisture seal. Retention of moisture for curing by any of the above methods shall be continued for a minimum of 7 days.
  - b. If the precast concrete barrier sections are steam cured, the sections shall be cured in an enclosure free from outside drafts, and cured in a moist atmosphere. The temperature shall be maintained at a temperature between 125 degrees and 160 degrees F by the injection of steam for a period of not less than 12 hours. Steam curing shall not begin in less than 2 hours from the time that the last concrete was placed. Care shall be taken by the manufacturer to prevent localized "hot spots" caused by

the steam lines. A continuous temperature time recorder is required for each enclosure. The temperature of the curing atmosphere for any method shall not be increased or decreased at a greater rate than 40 degrees F per hour.

5. Repair: Where approved by the Engineer, occasional imperfections in manufacture or those caused by mishandling may be repaired. The repairs shall be properly finished and cured. The color of the repaired area shall match as closely as possible the rest of the barrier color. The repairs may be made with a mixture of sand and cement. The repairs shall be made to the satisfaction of the Engineer.

#### 2.04 FINISHES

- A. Steel guide rails, posts, anchoring devices, bolts, nuts and washers shall be galvanized in accordance with the requirements of General Specification 05081-Galvanizing.
- B. Precast concrete barriers shall not receive a protective coating.

#### 2.05 SOURCE QUALITY CONTROL

- A. Tests and Inspections:
  1. Precast Concrete Barrier: The acceptance of the manufactured precast concrete barrier sections will be determined by the Engineer in accordance with either of the following methods at the option of the Engineer.
    - a. Production Testing: Testing shall be performed by the manufacturer, subject to the approval and inspection of the Engineer. It shall consist of testing the freshly-mixed concrete for compliance to the air content required by General Specification 03300 – Cast-in-Place Concrete, and the casting and testing of concrete cylinders for compressive strength determination. Test cylinders used to determine the required compressive strength shall be cured with units they represent. The City reserves the right to test the hardened concrete at any time, in which case the manufacturer shall drill 4-inch diameter cores at the direction of the Engineer.
    - b. End Product Testing: The testing of hardened concrete for both air content and compressive strength will be performed by an approved testing laboratory on 4-inch diameter cores drilled by the manufacturer where directed by, and in the presence of, the Engineer.



PART 3 EXECUTION

3.01 INSTALLATION

A. Steel Guide Rail:

1. Methods: Posts, rails, end assemblies and other parts of the corrugated beam guide rail system shall be erected parallel to the roadway and as indicated on the NYSDOT standard sheets and in conformance with the requirements of the NYSDOT Standard Specifications, except as specified herein.
2. Curved Rail Elements: Straight lengths of rail elements may be used between end posts when the radius of curvature of a line passing through the centerline of installed posts is equal to or greater than 700 feet. When the said radius of curvature is less than 700 feet and greater than 150 feet, rail elements shall be curved to match the actual radius of curvature.
3. Splicing: Rail elements shall be spliced at each post so that the rail element which is nearest oncoming traffic overlaps the element which is furthest.
4. Attachment: To prevent loosening, bolt threads close to the nut shall be upset after a connection has been tightened to final position. Upset threads shall be completely sealed against corrosion by the application of an approved aluminum paint.

B. Precast Concrete Barrier:

1. Precast concrete barrier sections shall be installed with ½-inch nominal joint openings. The joint opening, at any point in the plane of the joint, shall be not less than ½ inch and no more than 1 inch. Premolded resilient joint filler conforming to the requirements of NYSDOT Standard Specifications Section 705-07 or preformed closed cell foam material conforming to the requirements of Section 705-08, Type II Joint Filler shall be placed in the joint.

3.02 FIELD QUALITY CONTROL

A. Steel Guide Rail:

1. Inspection of Railing: Immediately prior to erection, the railing will be inspected for damage. Bends or kinks in the railing not specifically required by the Contract Drawings shall constitute sufficient cause for rejection. Straightening of such bends or kinks will not be allowed. Bending or curving railing panels or rails, not for uniform bending to form curves with radii greater than 150 feet, but for the purpose of adjusting for misalignment, will not be permitted. The Engineer may

## GENERAL SPECIFICATION 02841 GUIDE RAILING

---

order some bending or curving to allow for necessary minor adjustments.

2. Inspection of Galvanizing: Damage to galvanizing shall constitute sufficient cause for rejection, except for the following conditions:
    - a. If the total damaged area of a complete railing panel is less than two percent of the total surface area, or sixteen square inches, whichever is less.
    - b. If the total damaged area of a single piece (i.e., post or rail) is six square inches, or less
  3. Field Galvanizing for Repair: Field galvanizing repair shall be allowed to be performed upon damaged areas meeting the requirements of Paragraphs 3.02A.2.a. and b. above. Field galvanizing repair shall be made by painting zinc repair materials onto the damaged area in accordance with the requirements of Section 719-01, Galvanized Coatings and Repair Methods, of the NYSDOT Standard Specifications.
    - a. All finished surfaces of welds and adjacent surfaces or rails and posts upon which galvanizing has been removed, due to any field welding operation, shall be rejected and replaced.
    - b. Any railing panel with a total damaged area in excess of the amount specified or any single piece with a total damaged area in excess of the amount specified shall be rejected and replaced.
  4. Field Welding: Field welding will not be permitted unless noted on the Contract Drawings.
- B. Precast Concrete Barrier:
1. Inspection of Precast Concrete Barriers: Barrier sections will be inspected by the Engineer before installation in the field to ascertain the type and extent of defects, if any.
  2. Defects: Defects are divided into two categories (minor defects and major defects). Minor defects in the barrier may be repaired in the field. Major defects shall be cause for rejection of the section, or the section shall be repaired in the manner directed by the Engineer.
    - a. Minor defects are defined as holes, honeycombing or spalls which are six inches, or less, in diameter, and which do not expose the outermost surface of the steel reinforcement. Surface voids 5/8 inch, or less, in diameter, and 1/4 inch, or less, in depth are not considered defects and they do not require repair.
    - b. Major defects are defined as:

## GENERAL SPECIFICATION 02841 GUIDE RAILING

---

- 1) Any defect which does not meet the definition of a minor defect.
  - 2) Minor defects which, in aggregate, comprise more than 5 percent of the surface area of the barrier section.
3. Repair of hardened concrete shall be as follows:
- a. Minor Defect Repair: Repair shall be made with a material meeting the requirements of Section 701-04 of the NYSDOT Standard Specifications. Methods of repair shall be acceptable to the Engineer. The color of the repaired portion shall match, as nearly as practicable, the color of the surrounding concrete. Repaired portions shall exactly match shape requirements. The repaired portion shall withstand a moderate blow from a 16-ounce hammer.
  - b. Major defect repair shall be preapproved by the Engineer.

END OF SECTION

**GENERAL SPECIFICATION 02841 GUIDE RAILING**

---

NO TEXT ON THIS PAGE

**SECTION 02910  
Planting**

**PART 1 GENERAL**

**1.01 SUMMARY**

- A. Planting as specified herein includes, but is not limited to, the following:
  - 1. Furnishing and installing new trees, shrubs, grasses, and all other plant materials.
  - 2. Furnishing and installing new seeded, hydroseeded, and sodded areas.
  - 3. Staking and guying of trees, only where shown on the Drawings or as directed.
  - 4. Furnishing and installing filter fabric and drainage gravel under planted areas, in areas as shown on the Drawings.
  - 5. Furnishing and installing mulch.
  - 6. Protection and maintenance of all plant materials and the replacement of plantings as required until Substantial Completion.
  - 7. Guarantee of all new plant materials for 18 months after Substantial Completion, unless otherwise required in the Detailed Specifications.
  - 8. Plant protection, maintenance and replacements during guarantee period.
  
- B. The Contractor shall implement practices and procedures to meet the project’s sustainability goals as identified in the Contract Documents. The Contractor shall ensure that the sustainability requirements of this Section are implemented to the fullest extent.
  
- C. The following index of this Section is included for convenience:

<u>Article</u>	<u>Title</u>	<u>Page</u>
		02910-
PART 1	GENERAL .....	1
1.01	Summary .....	1
1.02	Payment.....	2
1.03	Related Sections.....	2
1.04	References.....	2
1.05	System Design Requirements .....	3
1.06	Quality Assurance .....	4
1.07	Submittals .....	4
1.08	Delivery, Storage And Handling.....	6
1.09	Coordination .....	7
1.10	Substantial Completion.....	7
1.11	Warranty (Guarantee Period).....	7

## GENERAL SPECIFICATION 02910 - PLANTING

---

PART 2	PRODUCTS.....	9
2.01	Manufacturers And Suppliers .....	9
2.02	Materials .....	10
PART 3	EXECUTION.....	15
3.01	Examination .....	15
3.02	Preparation For Planting .....	16
3.03	Plant Installation .....	16
3.04	Preparation For Seeding And Sodding .....	20
3.05	Sodding & Seeding Operations.....	21
3.06	Plant Protection & Maintenance .....	24
3.07	Clean Up .....	27
1.02	PAYMENT	
A.	No separate payment will be made for performing any work of this Section and the Contractor shall include all costs thereof in its lump sum price bid for the Contract, except as provided for otherwise in the Detailed Specifications.	
1.03	RELATED SECTIONS	
A.	General Specification 02317 - Backfilling	
B.	General Specification 02371 - Dust, Soil Erosion & Sedimentation Control	
C.	General Specification 02920 - Soil Mixes	
1.04	REFERENCES	
A.	American Nursery and Landscape Association (ANLA)	
1.	American Standard for Nursery Stock (ASNS), ANSI Z60, current edition	
B.	International Society of Arboriculture (ISA)	
1.	American National Standard for Arboricultural Operations – Pruning, Repairing, Maintenance, and Removing Trees, and Cutting Brush – Safety Requirements, ANSI Z133, current edition	
C.	Tree Care Industry Association (TCIA), Standards	
1.	American National Standard for Tree Care Operations – Tree, Shrub and Other Woody Plant Management – Standard Practices, ANSI A300, current edition.	
D.	Manual of Vascular Plants of Northeastern United States and Adjacent Canada, 2nd ed., 1991, by Henry A Gleason and Arthur Cronquist (G&C), New York Botanical Garden	

- E. Revised Checklist of New York State Plants (NYSPC), Richard S. Mitchell and Gordon C. Tucker, New York State Museum
- F. New York Flora Atlas (<http://newyork.plantatlas.usf.edu/Default.aspx>)
- G. USDA Plant Database (<http://plants.usda.gov/java/>) & USDA Plant Hardiness Zone Map (<http://planthardiness.ars.usda.gov/PHZMWeb/>)

1.05 SYSTEM DESIGN REQUIREMENTS

- A. Contractor shall locate all required plant materials and be present for their inspection, as directed by the Engineer or the Engineer’s designated representative, at the nursery prior to transport or upon delivery of the materials on site. Notify the Engineer at least 14 days in advance of the Contractor’s desired inspection dates and locations.
- B. Inspection at Nursery: All plants may be inspected and selected by the Engineer or designated representative at the nursery for conformity to the requirements of the Contract. Whether plant materials are inspected or not at the nursery, the Contractor shall make all preselection arrangements required by the Engineer to ensure an efficient selection procedure. Approval of plant materials at the nursery shall not affect the rights to inspect or reject the materials upon delivery or later.
- C. Inspection at Delivery On-Site: Notify the Engineer at least five (5) working days in advance of delivery of plants to the site.
  - 1. The Engineer or Engineer’s designated representative will inspect all plants upon delivery to site.
  - 2. Contractor shall schedule a time for on-site inspection prior to planting, and shall arrange for adequate labor and equipment on-site at the time of inspection to unload, open, and handle plants during inspection.
  - 3. The Engineer or Engineer’s designated representative may reject any plant material prior to or upon delivery to the site.
    - a. All plant material that is dead, dying or appears unhealthy will be rejected.
    - b. All plant material that has been improperly maintained, dug, transported or handled in such a way as to impair its appearance or health will be rejected.
- D. The Engineer or Engineer’s designated representative will be the sole judge of the condition of the plants.
  - 1. All material that is rejected on site shall be removed immediately from site, and replaced with new material selected or approved by the Engineer, at no additional cost to the City.

## GENERAL SPECIFICATION 02910 - PLANTING

---

- E. Sustainable Design Requirements:
  - 1. Regional Materials: Provide plant materials that were grown and harvested, or extracted, within 250 miles of the project site unless otherwise required in the Detailed Specifications or shown on the Drawings.
- F. Project-specific system design requirements will be provided in the Detailed Specifications, if necessary, to supplement requirements given herein or in the Contract Drawings.

### 1.06 QUALITY ASSURANCE

- A. Comply with all rules, regulations, laws and ordinances of local, state and federal authorities having jurisdiction. Provide labor, materials, equipment and services necessary for work to comply with such requirements at no additional cost to City.
- B. Procure and pay for permits and licenses required for work of this Section. Obtain all required permits in a timely manner to avoid delays to the work.

### 1.07 SUBMITTALS

- A. Submit a Statement of Qualifications for the landscape subcontractor. Qualifications shall show experience in the installation of landscape work of a similar type and scale to this project within the last six (6) years.
- B. Statement of Qualifications for the landscape subcontractor shall consist of the following information:
  - 1. Company name and address
  - 2. Number of years in business under this name
  - 3. Number of current full-time, part-time, and seasonal employees
  - 4. Estimated number of employees intended for this project
  - 5. Current workload:
    - a. Name and address of current projects
    - b. Types and dollar amounts of work for which landscape subcontractor is responsible in each current project
    - c. Estimated completion date for each current project
  - 6. References for three (3) projects completed within the last six (6) years, which are similar in scope to this project, including the following information for each project:
    - a. Name and address of project
    - b. General description of work
    - c. Dollar amount of landscape work performed



## GENERAL SPECIFICATION 02910 – PLANTING

---

- d. Dates landscape work was started and completed
  - e. Verified contact information for at least one (1) representative of the owner or prime construction contractors in each projects:
    - 1) Name,
    - 2) Mailing address,
    - 3) E-mail address, and
    - 4) Telephone numbers (Office and Direct).
  - f. Contact information similar to above for at least one (1) representative of the Architect, Engineer, Landscape Architect, or other representative of the designer or construction manager for each project given as reference.
- C. Samples: Submit samples of the following items:
- 1. Mulch: One (1) pound bag with manufacturer’s certification of content
- D. Growers/Nurseries: Contractor shall submit a list of proposed growers/nurseries prior to the commencement of any landscaping work, with sufficient advance notice of at least 60 days or as stated in the Detailed Specification.
- E. For nurseries, a copy of state inspection certificate for current year must be submitted.
- F. Materials/Certificates: Contractor shall submit a list of all materials and certificates specified in this Section prior to the commencement of any landscaping work, with sufficient advance notice of at least 30 days or as stated in the Detailed Specification.
- G. All necessary state, federal and other inspection certificates as may be required by law.
- H. Product Data - Where applicable, the following product data shall be submitted:
- 1. Manufacturers’ product information for filter fabric, showing conformance with the specified requirements.
  - 2. Analysis of each seed or hydroseed mix to be used, showing percentage of purity, weed content and germination of seed.
  - 3. Identification of sod source and certification that all sod material is true to name, type, purity and other criteria in conformance with these specifications.
  - 4. Certified analysis for each treatment, amendment, and fertilizer material specified and as used, including weight for packaged material.
- I. Documentation: The Contractor shall submit written documentation at least 30 days prior to scheduled start of planting that all plant material has been ordered.

## GENERAL SPECIFICATION 02910 - PLANTING

---

J. Maintenance Program: Submit written schedule of maintenance operations proposed for the guarantee period. Schedule shall be in the form of a list of all proposed maintenance tasks, with dates showing when each maintenance task will be performed and its frequency of occurrence.

K. Sustainable Design Submittals:

1. Environmental Materials Reporting Form (EMRF) Regional Materials. Provide the following information:
  - a. Name of Product and Manufacturer.
  - b. Material cost breakdowns. Cost breakdowns must include total material-only cost (excluding installation, labor and equipment).
  - c. Indicate the location and distance from Project of material manufacturer and point of extraction, harvest, or recovery for each raw material. For assemblies, include the percentage by weight that is considered regional.

### 1.08 DELIVERY, STORAGE AND HANDLING

A. Packaged Materials

1. Deliver packaged materials in unopened bags or containers, each clearly bearing the name of the producer, the material composition, manufacturers' certified analysis, and the weight of the material.
2. All packaged products shall be stored, handled and applied in strict accordance with manufacturers' instructions.

B. Dig and handle all plant material to prevent injury to trunks, branches and roots.

1. All plants specified as B & B (balled and burlapped) in the Plant List shall be dug to depths as required in the Detailed Specifications with sufficient roots and shall have a solid ball of earth securely held in place by burlap and rope.
2. Do not prune prior to delivery.
3. Do not bend or bind-tie trees in such manner as to damage bark, break branches or destroy natural shape.

C. Pack and ship all plant material to ensure arrival at site in good condition. Provide protective covering during delivery.

D. If planting is delayed more than 24 hours after delivery, Contractor shall provide adequate means of protection from freezing and from the drying effects of wind and sun.

1. Rootballs shall be protected with soil, wet mulch, or other acceptable material.

## GENERAL SPECIFICATION 02910 – PLANTING

---

2. Provide shade structures or other covering as required to protect branches and leaves.
  3. Water as necessary until planted. Do not allow plant material to wilt or show signs of stress from lack of water. Provide all water and equipment for water distribution at no additional cost to the City.
- E. Immediately remove rejected or damaged plant material from the site and replace with plants approved by Engineer. All replacement plants shall be subject to the same requirements as the original material.
- 1.09 COORDINATION
- A. The Contractor shall coordinate its work with that of other Contractors. Such coordination shall include, but not be limited to:
1. Location of all underground utility lines and structures
  2. Scheduling of planting operations
  3. Scheduling of maintenance operations
- 1.10 SUBSTANTIAL COMPLETION
- A. Contractor shall submit a written request to the Engineer, for a formal inspection of the planting work for Substantial Completion.
- B. To be accepted at the time of formal inspection of planting work, all plant material must be alive, healthy, and installed as specified.
1. If plants are dead, dying, or unhealthy, or if landscaping does not serve its visual or soil stabilization functions, or if workmanship is unacceptable to the Engineer or Engineer's Representative for other reasons, written notice will be given to the Contractor in the form of a punch list that itemizes all remedial work required for Substantial Completion.
  2. This work may include plant replacement or maintenance which must be carried out prior to issuance of the Certificate of Substantial Completion.
  3. The Certificate of Substantial Completion will not be issued until a written maintenance program, as described herein below, has been approved by the Engineer and the Engineer's designated representative.
- 1.11 WARRANTY (GUARANTEE PERIOD)
- A. All new plant material shall be guaranteed for a period of 18 months after the date of Substantial Completion, unless otherwise required in the Detailed Specifications.

## GENERAL SPECIFICATION 02910 - PLANTING

---

### B. Protection and Maintenance

1. At least 30 days prior to the date of the written request for Substantial Completion, Contractor shall submit a written protection and maintenance program and schedule to the Engineer for approval.
2. Protection and Maintenance program shall be revised and resubmitted as required until approved by Engineer.
3. During the guarantee period, the Contractor shall maintain all plant materials as specified herein, and as noted in the approved maintenance schedule, and shall replace, at no additional cost to the City, any and all plant material that has died or, in the opinion of the Engineer or Engineer's designated representative, is in unhealthy or unsightly condition.
4. The Contractor is responsible for providing and maintaining adequate protection measures for all planted areas throughout the guarantee period in order to protect plantings from by any subsequent construction operations or other types of physical damage.
  - a. Protection measures may include, but not be limited to, approved temporary fencing, tree guards, signage and other measures as determined to be necessary during the guarantee period.
  - b. Local fence ordinances and guidelines may also apply to the work requiring the Contractor to submit at no additional cost to the City design drawings or other documents for obtaining the necessary local permits or approvals.

### C. Replacements

1. There will be no limit to the number of times replacements are made of individual plants, unless conditions causing the failure can be proved to be beyond the control of the Contractor.
2. The Contractor is responsible for replacing any and all plant material and any associated compacted soils that are damaged by the Contractor's own operations or the operations of any of its subcontractors, or due to other damage resulting from a lack of adequate protective measures, at no additional cost to the City.
3. All replacements shall be in accordance with original specification or, if it is determined that specified plants are inappropriate for as-built conditions, they may be replaced with the approval of Engineer or Engineer's Representative to more appropriate species as identified by a Restoration Specialist, Landscape Architect or other qualified professional.

4. Cost of all replacements shall be included in the Contract price. No additional payment will be made therefor.
  5. Replace unacceptable plant material no later than the next succeeding planting season.
  6. Guarantee all replaced material for a period of 18 months after the date of replacement, unless otherwise required in the Detailed Specifications.
  7. All areas damaged or soiled by replacement planting operations are to be fully restored to their original condition at no additional cost to the City.
- D. Site Inspection
1. Approximately one (1) month prior to the expiration of the guarantee period, the Contractor shall arrange a site inspection by the Engineer.
  2. At this time, the Engineer will prepare a list of all remedial work required, including plant replacement and maintenance.
  3. This work shall be carried out before the end of the guarantee period, unless weather conditions cause delays, in which case such work shall be carried out as soon as is practical.
- E. Final Acceptance
1. Following the completion of all remedial work and replacement plantings, the Contractor shall request the Engineer in writing for a formal inspection of the landscape work for Final Acceptance.
  2. If replacement plantings are required, Final Acceptance will be provisional upon a final inspection at the end of the guarantee period for the plant replacements.
- F. All of the materials and labor required for plant protection, maintenance and replacements during the guarantee period shall be included in the Contractor's bid price. No additional payments will be made therefor.

## PART 2 PRODUCTS

### 2.01 MANUFACTURERS AND SUPPLIERS

- A. Acceptable manufacturers and suppliers of planting materials shall be as indicated below unless otherwise specified in the Detailed Specifications.
1. Hardscrabble Farms Nursery, North Salem, NY ([www.hardscrabblefarms.com](http://www.hardscrabblefarms.com))
  2. Pinelands Nursery, Columbus, NJ ([www.pinelandsnursery.com](http://www.pinelandsnursery.com))
  3. New England Wetland Plants, Inc., Amherst, PA ([www.newp.com](http://www.newp.com))

## GENERAL SPECIFICATION 02910 - PLANTING

---

4. Sylva Native Nursery & Seed Company, Glen Rock, PA ([www.sylvanative.com](http://www.sylvanative.com))
  5. Octoraro Native Plant Nursery, Kirkwood, PA ([www.octoraro.com](http://www.octoraro.com))
  6. Northcreek Nurseries, Oxford, PA (<http://www.northcreeknurseries.com>)
  7. Or Approved Equal
- B. All nurseries supplying plant material shall have a registration certificate from the Department of Agriculture and Markets, Division of Plant Industry, New York (or similar organization in the state from which plant material is obtained) certifying that the plant material is apparently free of injurious insects and diseases.

### 2.02 MATERIALS

- A. Plants
1. Provide plant material to meet or exceed applicable ANLA standards in all ways in addition to other standards specified. Plant names, size and grading standards shall conform to those prepared by American Nursery and Landscape Association (American National Standards Institute), American Standard for Nursery Stock (ANSI Z60.1, latest edition). Plants shall be true to species and, if specified as to variety or cultivar, shall be as listed in <http://newyork.plantatlas.usf.edu/Default.aspx> to determine nativity and as listed in <http://plants.usda.gov/java/> for taxonomy. Plants shall be typical of their species or variety with normal habits of growth, in accordance with ASNS: Sound, healthy and vigorous, well-branched and densely foliated when in leaf, with healthy well developed root systems; free from disease, abrasions of the bark, insect pests, eggs or larvae.
  2. Plant species native to the Eastern United States, as specified in the planting plan and Detailed Specification, shall be provided by the Contractor. Non-native species shall not be considered as substitutes for native species.
  3. Native plant material shall be derived from the local genotypes of the native plants specified to the greatest extent practicable. Plants must be nursery grown in hardiness zones no warmer or colder than the project sites as determined by the USDA Agricultural Research Service, Plant Hardiness Zone Map.
  4. Plants that have escaped cultivation, or have accidentally been introduced into native habitats, shall not be considered native to the Eastern United States. Refer to USDA Plants Database for taxonomy and to G&C, NYSPC and the New York Flora Atlas to determine nativity.

## GENERAL SPECIFICATION 02910 – PLANTING

---

- a. No plant material shall be collected or harvested from non-nursery areas.
  - b. All trees shall be freshly dug for this project.
5. Sources: Nursery sources of supply shall have been investigated by the Contractor prior to submitting its bid to confirm that size, variety, and quantity of plant material specified on the Plant List can be supplied. Failure to take this precaution will not relieve the Contractor from the responsibility for furnishing and installing all plant material in strict accordance with the Contract requirements and without additional expense to the City.
6. Quality: All woody plant material shall be nursery grown in accordance with good horticultural practice, for at least two (2) years under climatic conditions and soils similar to those at project site. All plants shall be of specimen quality. All trees are to be uniform and matched. All trees shall have straight trunks with leader intact, undamaged and uncut. Trees with damaged or crooked leaders, bark or abrasions, sunscald, disfiguring knots, or insect damage will not be accepted.
7. Depth of planting shall be checked on all trees being tagged at the nursery. Remove all soil or other fill material above the natural point where the tree trunk begins to spread, (the flare), prior to digging and ball and burlap operations.
8. Size:
  - a. Caliper measurement shall be taken on the trunk at 6 inches above the natural ground line for trees up to and including 4 inches in caliper, and 12 inches above the ground for trees greater than 4 inches in caliper.
  - b. Height and spread dimensions refer to the main body of plant, and not from branch tip to tip.
  - c. If a range of size is given, no plant shall be less than the minimum size and not less than 50 percent of the plants shall be as large as the maximum size specified.
  - d. Plants that meet measurements but do not possess a normal balance between height and spread shall be rejected.
  - e. Plants larger than specified may be used only if approved by Engineer. Use of such plants shall not increase the contract price. If larger plants are approved, the root ball shall be increased in proportion to the size of the plant. The Contractor shall verify that the size of the root ball will fit in prepared planting pits.

## GENERAL SPECIFICATION 02910 - PLANTING

---

9. All trees shall be balled and burlapped stock (B&B), with a compact natural ball of earth, firmly wrapped and tied in burlap fabric.
  - a. Root ball sizes shall be in accordance with standards specified in ASNS.
  - b. Plants with cracked or broken rootballs will not be accepted.
  - c. Only natural burlap fabric shall be acceptable for balling. Plastic and other non-biodegradable fabrics will not be accepted.
- B. Staking and Guying Materials
  1. Stakes (where specified only): 3-inch diameter cedar, fir, or hemlock stakes, with pointed ends. Stakes shall be straight, sound, and free from defects that may impair strength.
  2. Tree tie:  $\frac{3}{4}$ -inch thick polypropylene woven tree tie
- C. Drainage Gravel
  1. Drainage fill shall conform to the requirements of General Specification 02317 - Backfilling, and shall be clean, free from silt and organic materials.
- D. Mulch
  1. Mulch shall be a double-shredded natural forest product of a uniform grade, partially decomposed, dark brown in color, free from sawdust, with no additives or any other treatment. Size of bark shall be from  $\frac{5}{8}$  inch to one and  $\frac{1}{4}$  inch. The pH range shall be 5.8 to 6.2.
  2. Mulch sources shall be free of diseases or pest infestations including but not limited to the Emerald Ash Borer or Asian Longhorned Beetle. Use of material from any areas that have been designated for quarantine of wood products by any state or federal agency is strictly prohibited.
- E. Sod Grass
  1. All sod shall be vigorously growing, thick, uniform, fully established, and well-developed turf grasses from an approved single source sod farm, New York State Certified.
  2. All sod shall conform to the following seed types and proportions:
    - a. 30% - One or two of the following Bluegrasses: Victa, Blacksberg, Preakness, Rugby, Dragon, Challenger or Unique
    - b. 35% - One or two of the following shade-tolerant Bluegrasses: Able, Eclipse, Nustar, Warrens A-34, Bristol, Touchdown, or P-105
    - c. 30% - One of the following fine fescues: Aurora, Shadow or Discovery



3. Quality
    - a. All sod shall be certified free of disease, insect pests, eggs, larvae, fungi, and blight, as required by regulatory authorities.
    - b. All sod shall be free from noxious weeds, annual grasses, moss, large stones, tree roots, or other materials harmful to growth or that will interfere with future mowing or other maintenance of the sodded areas.
    - c. Sod sections shall be strong enough to support their own weight when held vertically with a firm grasp on upper 10 percent of pad.
    - d. All sod sections shall be uniformly moist and not excessively dry or wet.
    - e. Broken pieces and torn or uneven ends shall not be accepted.
  4. Size
    - a. All sod shall be machine cut strips, in supplier's standard widths and lengths, but not less than 12 inches wide.
    - b. Thickness of pad shall be uniformly 3/4-inch ("1/4"), excluding top growth and thatch.
    - c. Each sod piece shall be cut to a uniform size with square corners.
  5. Sod shall be freshly harvested, delivered, and installed within a period of 24 hours. Sod not installed within this time period shall be separately approved by the Engineer and shall be subject to conditions of material rejection.
- F. Grass Seed for Lawn Areas
1. Grass seed for lawn areas shall be fresh recleaned seed of the latest crop. Unless otherwise specified in the Plans or Detailed Specifications, seed mixture shall have the following proportions by weight:
    - a. 60% Kentucky Bluegrass
    - b. 20% Fine Fescue
    - c. 20% Perennial Ryegrass
  2. Seed shall be Tri-Plex General seed mix by Lofts Seed Inc., or approved equal.
  3. All seed shall be delivered in standard size bags of the vendor, showing weight, purity, and percentage of seed varieties.
  4. Grass seed for lawn areas shall be provided only for areas where lawn is specified. It shall not be furnished for temporary stabilization prior to final site restoration in restoration projects.

## GENERAL SPECIFICATION 02910 - PLANTING

---

- G. Grass Seed for Hydroseeded Areas
1. Grass seed mix for hydroseeding shall be fresh recleaned seed of the latest crop. Seed mixture shall have the following proportions by weight:
    - a. 40% Creeping Red Fescue
    - b. 30% Perennial Ryegrass
    - c. 20% Annual Ryegrass
    - d. 10% Kentucky Bluegrass
  2. All seed shall be delivered in standard size bags of the vendor, showing weight, purity, and percentage of seed varieties.
  3. Grass seed for hydroseeding shall be provided only for areas where hydroseeded turfgrass is specified. It shall not be furnished for temporary stabilization prior to final site restoration in restoration projects.
- H. Native Grass and Wildflower Seed Mix
1. Seed for native grass and wildflower seeded areas shall be fresh recleaned seed of the latest crop. Seed mixture shall contain the following:
  2. Seed shall be as specified on the Drawings or in the Detailed Specifications.
  3. All seed shall be delivered in standard size bags of the vendor, showing weight, purity, and percentage of seed varieties.
- I. Filter Fabric
1. Filter fabric shall be non-woven type conforming to the requirements of General Specification 02371 - Dust, Soil Erosion & Sedimentation Control.
- J. Water
1. The Contractor shall be responsible for supplying all required water to the site at no additional cost to the City. In upstate projects, the Engineer of Record will coordinate with the Contractor to locate a source of water
  2. Where water is supplied from City hydrants, the Contractor shall obtain a free hydrant permit from the Department of Environmental Protection, Bureau of Consumer Service, (718 595 6699). Permits are issued for a 30 day period, and the Contractor is responsible for keeping the permit current. The permits are available from each borough office. To obtain a permit, the Contractor should bring a copy of their DEP contract indicating exemption from the permit fee, as described in Article 13,

with a general description of the hydrant location(s) they propose to access.

3. The Contractor must have all tools necessary for using city hydrants in his possession at time of planting to ensure that this section is adhered to. If conditions do not allow the use of New York City water sources, the Contractor must obtain his/her own source of water. No direct payment shall be made for water obtained from other than city sources, but the cost thereof shall be deemed included in of the contract.
  - a. All work injured or damaged because of the lack of water, or the use of too much water, or the use of contaminated water shall be the Contractor's responsibility to correct.
  - b. Water shall be free from impurities injurious to vegetation.

K. Tree Irrigation Bags

1. Unless otherwise shown on the Drawings, required in the Detailed Specifications, or directed by the Engineer, the Contractor shall furnish tree irrigation bags for all trees over 1-1/2 inch caliper. The irrigation bags shall be 100% reinforced UV stable polyethylene, at least 10 mils. thick with a polyester scrim lining, such as TreeGator, as manufactured by Spectrum Products, Raleigh, NC, or approved equal. The irrigation bags shall have a minimum 20-gallon capacity.

PART 3 EXECUTION

3.01 EXAMINATION

- A. Drainage at tree pits: Check drainage at tree pits prior to planting, by performing percolation tests (in dry weather) as follows:
  1. Dig out planting hole to required depth and fill hole half full of water. Mark water level with stake.
  2. Water level should decrease by a minimum of two (2) inches per hour.
  3. If water does not drain adequately from plant pits, amend conditions at tree pits and planting beds as required for satisfactory drainage. If topsoil or subgrade has been over-compacted by the Contractor's operations, such as by compaction equipment or by allowing vehicles or equipment to pass over the area, the Contractor shall remove and replace over-compacted materials at its own expense.
  4. Obtain approval of Engineer for proposed amendments.
  5. Do not place trees in pits until approval of drainage conditions by the Engineer.

## GENERAL SPECIFICATION 02910 - PLANTING

---

- B. The Contractor shall be liable for all damage to surrounding areas caused by planting operations and shall be required to restore or replace the damaged areas to their original condition.
- C. Contractor is responsible for determining the location of all utilities, by contacting the appropriate utility company prior to any planting activities.
  - 1. Verify that underground utilities and irrigation systems in landscape areas are in place, at the proper location, tested (except final irrigation testing) and ready for use.
    - a. Take proper precautions so as not to disturb or damage sub-surface elements.
  - 2. Coordinate with other trades.
- D. The Contractor is liable for any damage to such utilities during the course of construction, and is responsible for making necessary repairs to damaged utilities at its own expense.

### 3.02 PREPARATION FOR PLANTING

- A. Install filter fabric under planted areas, in areas shown on the Drawings.
  - 1. Fabric shall be overlapped by a minimum of six (6) inches.
  - 2. Fabric shall be held in place with wire staples of adequate quantities to prevent movement of fabric during planting operations.
  - 3. Fabric ends shall be secured in trenches as shown on the Drawings.
  - 4. No fabric shall be visible following completion of planting and seeding operations.
- B. Planting soil mix materials and installation shall be as specified in General Specification 02920 - Soil Mixes.
- C. Exercise extreme caution during excavation to avoid damaging or interrupting existing underground utilities. Use appropriate detection equipment to locate utilities during excavation for planting.
- D. Erect barricades, warning signs, or other protective devices as may be required by local, state, or federal laws and regulations to protect open excavations.

### 3.03 PLANT INSTALLATION

- A. For projects within the immediate New York City area, plant only within the following dates, weather permitting. Refer to the Detailed Specification for approved planting dates for projects outside the City. Do not plant in times of high wind, rain, sleet, or snow when the ground is frozen or excessively wet; or when the soil is otherwise in an unsatisfactory condition for planting. Planting at times other than those specified will be at the Contractor's own risk, and will not invalidate any guarantees.

## GENERAL SPECIFICATION 02910 – PLANTING

---

1. B & B Deciduous trees and shrubs:
    - a. Spring: March 15 to May 15
    - b. Fall: October 15 to December 15
  2. The following trees shall be planted during the spring season only:
    - a. Acer rubrum
    - b. Betula sp.
    - c. Crataegus sp.
    - d. Liquidambar styraciflua
    - e. Liriodendron tulipifera
    - f. Platanus acerifolia
    - g. Prunus sp.
    - h. Quercus sp.
    - i. Salix babylonica
    - j. Tilia tomentosa
    - k. Zelkova sp.
  3. B & B Evergreen trees and shrubs
    - a. Spring: March 15 to May 15
    - b. Fall: September 1 to December 1
  4. Container-grown perennials, vines, and ground cover plants:
    - a. Spring: March 15 to July 1
    - b. Fall: September 1 to November 1
  5. Seeding, hydroseeding, and sodding shall be carried out during the following dates:
    - a. Spring: April 1 to June 1
    - b. Fall: September 1 to October 15
  6. Seeding shall be in moderately dry to moist soil, at such times when wind does not exceed five (5) miles per hour.
- B. Do not plant until plant material has been approved by the Engineer at site.
- C. Placement of Plants
1. Plants shall be set in the center of pits, plumb and straight, in accordance with the planting details, and faced to give best appearance and relationship to adjacent plants and structures.

## GENERAL SPECIFICATION 02910 - PLANTING

---

2. Plant to such depth that the finished grade level of plant, after settlement, will be the same as that at which the plant was grown.
  3. Trees must be planted at the depth of the flare, where roots spread from the trunk. The flare must be located and placed at the correct level before continuing planting operations.
- D. Planting Balled and Burlapped Trees and Shrubs
1. Excavate plant pits to minimum dimensions shown on the Drawings. If plant pits are mechanically dug, the sides of the pit shall be broken down or roughened with a shovel or other hand tool to eliminate surface glazing.
  2. Remove any platforms, wire, and surplus binding from top and sides of ball.
  3. Position plants in center of pit, using gentle handling to avoid damage to any part of the plant.
  4. Set plants on a bed of compacted soil mix, to position at the correct depth, as shown on the Drawings.
  5. Cut and remove burlap, rope ties, and wire baskets from the root ball, backfilling and gently removing burlap and wire basket in sections as needed to support the root ball.
  6. If wire baskets are used to contain the root ball, these shall be entirely removed before planting.
  7. Fully remove all burlap, non-biodegradable twine and other materials.
  8. Cleanly cut off all visible broken or frayed roots.
  9. Add mycorrhizal fungi inoculant, if specified, to each tree planting as per the approved manufacturer's or supplier's instructions.
  10. Apply water retention additive as per approved manufacturer's or supplier's instructions.
  11. Backfilling: Fill plant pit with soil mix by hand, in layers not more than six (6) inches deep, and with each layer thoroughly settled by hand tamping and with water, and free of all voids before next layer is put in place.
  12. Install tree irrigation bags and fill with water, unless otherwise specified or directed by the Engineer.
- E. Planting Perennials, Vines, and Container Grown Shrubs
1. Excavate plant holes to depth of container and twice the container diameter.

## GENERAL SPECIFICATION 02910 – PLANTING

---

2. Carefully remove plant from container using gentle handling to avoid damage to any part of plant.
  3. If roots are loose, spread roots out evenly over a mound of soil mix. If roots are tight and compact, loosen by pulling gently apart. If plant roots will not separate, use a sharp tool to make vertical slits in the root ball, approximately 1/2-inch deep at three or four locations around root mass.
  4. Set plants on a bed of compacted soil mix, so that the root ball is level with the surface of the soil.
  5. Backfilling: Fill plant pit with soil mix by hand, pushing the mix around and just over the surface of the root ball. Add soil mix in layers not more than four inches (4") deep, and with each layer thoroughly settled by hand tamping and with water, and free of all voids before next layer is put in place.
- F. Saucering
1. After backfilling is completed, a saucer shall be made for the retention of water around each plant, unless impracticable because of placement of tree gratings or other paving material over planted area.
  2. The saucer shall be of the same diameter as that of the hole dug.
  3. The lip shall be level all around and shall be at least 4 inches high for trees, and 2 inches high for shrubs.
- G. Watering
1. Immediately after installation of each plant, the soil around it shall be thoroughly saturated with water.
    - a. Apply water slowly so as to penetrate the entire root system.
    - b. Watering shall continue throughout the maintenance and guarantee period, as frequently as seasonal conditions require, until final acceptance of the work.
    - c. Contractor shall be responsible for adequate water both before and after installation of irrigation system.
- H. Mulching
1. After planting operations are complete all plant bed areas shall be covered with approved mulch.
    - a. Unless otherwise specified in the Drawings, mulch shall be installed at an even depth of three (3) inches over tree pit and shrub areas and two (2) inches over groundcover beds.

## GENERAL SPECIFICATION 02910 - PLANTING

---

- b. Mulch shall be contained within the plant bed areas and shall not be permitted to spread onto paved areas. Mulch shall not cover plants.

### I. Staking

- 1. Trees shall be staked only if shown on the Drawings, required in the Detailed Specifications, or directed by the Engineer.
  - a. Trees shall stand plumb after staking.
  - b. Do not use tree wrap.

### J. Pruning

- 1. Perform compensatory pruning following planting only as shown on the Drawings, required in the Detailed Specifications, or directed by the Engineer.
  - a. Excessive pruning at the time of transplanting must be avoided. The extent of top pruning should be based upon the ability of the plant roots to function.
  - b. Pruning shall be performed by a Certified Arborist in accordance with current best practices of the International Society of Arboriculture.
  - c. All deadwood, suckers, and broken or badly bruised branches shall be removed.
  - d. Pruning shall be done with clean, sharp tools.
  - e. No leaders shall be cut. Each cut shall be made carefully, at the correct location, leaving a smooth surface with no jagged edges or torn bark. The correct anatomical location is just beyond the branch collar.
  - f. Large or heavy limbs should be removed using three (3) cuts. The first cut undercuts the limb one or two feet from the parent branch or trunk. The second cut is top cut which is made slightly further out on the limb than the undercut. The third cut is to remove the stub.

### K. Antidesiccant Spraying

- 1. Use antidesiccant only as approved by Engineer. Approval is required for each condition of use.

## 3.04 PREPARATION FOR SEEDING AND SODDING

- A. All areas to be seeded or sodded shall be thoroughly loosened to a depth of 6 inches and graded to true lines free from all unsightly variations, bumps, ridges



or depressions. All sticks, stones, roots or other objectionable material shall be removed.

- B. Provide 12 inches of lawn soil mix, spread evenly over all areas to be seeded or sodded. Prepare topsoil to provide a crumbly seedbed, firm and level after tilling.
- C. After all materials have been worked in, firm up soil by rolling to eliminate all soft spots. Rake entire area into a crumbly state, with one inch of loose soil at the surface, using a wide-toothed rake or tine-harrow.
- D. For additional requirements on the use of soil amendments refer to General Specification 02920 – Soil Mixes.

### 3.05 SODDING & SEEDING OPERATIONS

#### A. Sodding Operations

- 1. Water the prepared soil bed between 12 and 24 hours prior to sod installation, sufficient to evenly moisten the soil mix, without over-watering or causing slipperiness.
  - a. Watering shall be carried out after the completion of soil mix placement, grading, settlement of soil surface, completion of remedial work and application of soil amendments.
- 2. Lay sod strips, after watering as specified, perpendicular to slope and edge to edge.
  - a. Place first row of sod in a straight line.
  - b. Place all subsequent rows parallel with joints butted tightly together and with staggered ends of sod strips.
  - c. Perimeter and border areas shall not be laid with less than full width sod or with less than one-half length sod.
  - d. Handle and lay without stretching of sod material.
  - e. All ends, joints and cuts shall be fitted and tightly joined so there are no voids or overlaps.
  - f. The final appearance shall be of a continuous lawn.
- 3. Tamp the sod lightly to ensure good contact with the soil surface and remove, replace, and re-tamp places of minor depressions or irregularities.
- 4. Finished grades at sod lawn areas shall be within one (1) inch of finished grades indicated on Drawings, except where lawn meets paved areas, there shall be no change of grade between lawn and pavement.

## GENERAL SPECIFICATION 02910 - PLANTING

---

- a. Finished grades shall allow free flow of surface drainage to catch basins without ponding.
5. Top Dressing
  - a. Following completion of all sod laying, the sod surface shall be top dressed with Lawn Soil Mix, conforming to General Specification 02920 - Soil Mixes.
  - b. The soil mix shall be screened to remove all materials larger than 1/2-inch.
  - c. Soil Mix material shall be worked into the seams between the sod pieces with a brush.
  - d. When finished, the sod shall present a smooth and uniform surface parallel to the finish grade.
  - e. Water all sod areas immediately following sod installation so that the sod surface and sod bed surface are thoroughly soaked.

### B. Seeding Operations

1. Prepare seedbeds in undisturbed areas by lightly tilling or harrowing to a depth of two (2) inches. No fertilizer is to be applied to wildflower or native grass areas. Prior to preparation of undisturbed sites, remove existing grass, vegetation and turf. Contractor shall take particular care so as not to damage existing plant material adjacent to seeding area while preparing seed bed. Dispose of removed vegetation off-site in accordance with all local laws: do not turn over into soil being prepared for native grass and wildflower seeding.
2. Moisten prepared seeding areas before planting if soil is dry. Do not create a muddy soil condition.
3. Apply seed with drop or cyclone spreader to uniformly cover seedbed at the rate required. In general, spring and summer seeding will be at a rate of 30 lbs./acre and winter seeding at a rate of 100 lbs./acre, per NYSDEC guidelines.
4. Small wildflower seeds should be mixed with damp sand and hand sown. Do not seed when wind velocity exceeds 5 miles per hour. Distribute seed evenly over the entire area.
5. Lightly rake seed into soil, and cover entire area with salt hay or straw, to a thickness of one (1) inch.
6. For larger areas, a mechanical power drawn seeder or combination grass planter and land packer or pulverizer may be used. Seed to be planted not deeper than 1/4 inch. Seeding operations shall be kept as close as possible to the contours and not up and down the slopes.

## GENERAL SPECIFICATION 02910 – PLANTING

---

7. Water all seeded areas immediately upon installation, taking care not to wash out the seeds, and regularly during first four (4) weeks following seeding to maintain adequate moisture for deep root growth.
  8. Seeding shall not be done on frozen ground or when the temperature is 32° F or lower. Do not use wet seed or seed that is moldy or otherwise damaged in transit or storage.
  9. Seeded areas shall be protected during establishment.
- C. Hydroseeding
1. All areas to be hydroseeded shall be thoroughly loosened to a depth of 6 inches and graded to true lines free from all unsightly variations, bumps, ridges or depressions. All sticks, stones, roots, or other objectionable material shall be removed.
  2. Provide six (6) inches of soil mix and spread evenly over all areas to be hydroseeded. Prepare topsoil to provide a crumbly seedbed, firm and level after tilling. For additional requirements on the use of crushed limestone in the soil mix, see General Specification 02920 – Soil Mixes.
  3. Apply hydroseeding solution with a mobile tank with a centrifugal pump, using a seeding nozzle of a design to produce an even distribution of the solution
  4. Clean and remove all hydroseeding solution from areas outside of the limits of hydroseeding, including removal from structures, walls, paving, trees and other plant material.
- D. Watering of Sodded, Seeded and Hydroseeded Areas
1. The Contractor shall provide all labor and arrange for all watering necessary to establish acceptable stands of planting in seeded areas. .
    - a. Begin watering immediately following installation.
    - b. Watering shall continue throughout the contract period until Substantial Completion.
    - c. During the first two (2) weeks after planting, in the absence of adequate rainfall, watering shall be performed up to three (3) times daily or as often as necessary and in sufficient quantities to maintain moist soil to a depth of at least two (2) inches.
    - d. After the first two weeks, the Contractor shall water the seeded areas to maintain adequate moisture in the upper two (2) inches of soil, necessary for the promotion of deep root growth.
  2. Watering shall be done in a manner that will provide uniform coverage, prevent erosion due to application of excessive quantities over small

## GENERAL SPECIFICATION 02910 - PLANTING

---

areas, and prevent damage to the finished surface by the watering equipment. The Contractor shall furnish sufficient watering equipment to apply one (1) complete coverage to the lawn areas in an eight (8) hour period.

### E. Reseeding

1. Any areas that fail to show growth within three (3) weeks of seeding shall be immediately reseeded at no additional cost to the City.
2. Reseeding shall be carried out as many times as necessary until a uniform grass cover is established.
3. Scattered bare spots, none of which are larger than one square foot, will be allowed up to a maximum of 3 percent of any seeded or hydroseeded area.

### F. Mowing

1. Mowing of all seeded, hydroseeded and sodded lawn areas shall begin when grasses and other plants are firmly rooted and secure, and shall continue until Substantial Completion.
2. Mow all grass lawn areas to maintain the grass height between 1-1/2 and 2-1/2 inches and meadow areas up to six (6) inches or as directed by the DEP Maintenance Supervisor.
3. Wildflower and native grass seeded areas shall be mown no more than two (2) times per year.
4. First mowing shall be carried out after seed set and shall not be carried out earlier than September 15 nor later than November 15. Mow to a height of not more than 9 inches.
  - a. Second mowing shall be carried out four (4) to six (6) weeks after first mowing, unless otherwise directed by DEP. Mow to a height of between 5 and 6 inches

## 3.06 PLANT PROTECTION & MAINTENANCE

### A. Plant Protection

1. The Contractor shall provide at its own expense all protection that is deemed necessary for all plants and lawn areas against damage prior to Final Acceptance of the work.
2. Removal of Temporary Protection Measures: All temporary protection measures employed during the construction period shall be removed prior to Substantial Completion unless otherwise directed by the Engineer. All stakes and ties used for temporary bracing of trees shall be removed and disposed of by the Contractor off site at its own expense

at the end of the guarantee period, or earlier at the direction of the Engineer.

**B. Plant Maintenance**

1. Maintenance of all plant material shall begin immediately after planting, and continue until the end of the guarantee period, unless otherwise noted.
2. Defective work shall be corrected as soon as possible after it becomes apparent and when weather season permits. The Engineer shall be the sole judge of the condition of the plants.
3. Maintenance shall include:
  - a. Watering, replanting, reseeding, resodding, repair of ruts and erosion, repair of protection devices, weeding and continuous control of invasive species, fertilizing and mowing of lawn areas.
  - b. The removal of all dead, dying or unhealthy plant material, including lawns, and replacement of such material with new plants or seeding to meet all specifications of the original plantings.
  - c. Protection from insects, disease, and invasive species to maintain optimum health. Infection or infestation may require removal and disposal off-site followed by replacement with plants free of infection at the discretion of the Engineer's designated representative.
  - d. The repeating of any or all phases of planting or lawn work as specified herein, or that may be required to obtain healthy plantings and a uniform, thick, and well developed stand of grass.
4. Specific Maintenance Tasks: Maintenance shall include, but not be limited to the following:
5. Watering: Water lawns and planted areas as required. Do not permit plant material to wilt or to show signs of stress from lack of water. Contractor shall supply and distribute water to all lawns and plantings during the full time of their establishment at the site and provide all equipment for water distribution at no additional cost to the City. Plants and lawns shall be inspected by the Contractor for watering needs at least once each week, and watered as necessary to promote plant growth and vitality.
6. Mowing: As described hereinbefore.

## GENERAL SPECIFICATION 02910 - PLANTING

---

7. Fertilizers: If applicable, apply any approved fertilizers, herbicides, pesticides or fungicides as required, or as directed by the Engineer, to keep all plantings healthy and pest-free throughout the guarantee period. Any fertilizers, herbicides or pesticides must be approved in advance by DEP.
8. Rodents: Protect against and exterminate rodents, and repair of any damage caused by rodent activities.
9. Weeding: Weed to keep all planted areas weed-free throughout the guarantee period.
10. Mulching: Add mulch material as required to maintain mulch at specified depth.
11. Resetting: Reset plant material that has settled, to proper grade and position.
12. Pruning: Prune trees and shrubs to remove all dead or broken branches, throughout the guarantee period. Prune flowering shrubs as necessary to ensure flowering.
13. Trimming: Cut back dead stalks, flowers and foliage from perennials in fall after the first frost. Trim or dead-head spent flower blossoms throughout the guarantee period.
14. Anchoring: Maintain any approved tree stakes, ties and other tree anchoring systems, including tightening, repair or replacement as required, and removal at the end of the guarantee period, or as directed by the Engineer.
15. Irrigation: If applicable, coordinate with irrigation system installer for all adjustments to irrigation as required.
16. Instruct City's maintenance personnel in all maintenance procedures.
17. Maintenance Program
  - a. Prior to Substantial Completion, the Contractor shall arrange a meeting with the Engineer, and with the City's designated maintenance personnel to review together the submitted maintenance program and any modifications required for the duration of the guarantee period.
  - b. The Contractor shall make periodic inspections, at no extra cost, during the guarantee period to determine what changes, if any, should be made in the maintenance program.
  - c. Any recommended changes shall be submitted in writing to the Engineer.

- d. Additional remedial work not included in the maintenance program shall be carried out by the Contractor as deficiencies are identified and reported by the Engineer or designated maintenance personnel.

18. Replacements

- a. In accordance with the requirements for Warranty (Guarantee Period) under this Section, the Contractor shall replace, as soon as weather conditions permit, and within a specified planting period, all plants determined dead and/or dying by the Engineer or the City's designated personnel during and at the end of the guarantee period. Replacements shall be made at no additional cost to the City. Labor and all materials needed for installation of replacements shall be included in the warranty. .
- b. Plants shall be free of dead or dying branches and shall bear foliage of normal density, size, and color.
- c. Trees having lost their central leader or exhibit crown dieback at the end of the guarantee shall be replaced.
- d. Replacements shall match adjacent specimens of the same species. Replacements shall be subject to all requirements stated in this Section.

3.07 CLEAN UP

- A. At the end of each work day the Contractor shall broom-clean the site, to remove all trash, debris, and loose soil materials. Store materials and equipment where directed.
- B. Immediately following the completion of planting operations, the Contractor shall remove all excess materials, stockpiles, waste materials, tools, and equipment, and leave the site in a clear and clean condition.
- C. Immediately remove all rejected materials from the site. All rejected materials and other waste or debris shall become the property of the Contractor, who shall legally dispose of same off-site.

END OF SECTION

**GENERAL SPECIFICATION 02910 - PLANTING**

---

NO TEXT ON THIS PAGE



**SECTION 02920  
SOIL MIXES**

**PART 1 GENERAL**

**1.01 SUMMARY**

- A. The work of this Section includes but is not limited to the following:
  - 1. Supply of component materials and soil amendments for soil mixes or supply of blended soil mixes from approved off-site sources.
  - 2. Reuse of existing topsoil stripped from site.
  - 3. Preparation of soil mixes on site.
  - 4. Installation, placement, spreading, and fine grading of soil mixes.
  - 5. Testing of all soil component materials, soil amendments, and soil mixes.
- B. The Contractor shall implement practices and procedures to meet the project’s sustainability goals as identified in the Contract Documents. The Contractor shall ensure that the sustainability requirements of this Section are implemented to the fullest extent.
- C. The following index of this Section is included for convenience:

<u>Article</u>	<u>Title</u>	<u>Page</u>
		02920-
PART 1	GENERAL .....	1
1.01	Summary .....	1
1.02	Payment.....	2
1.03	Related Sections.....	2
1.04	References.....	2
1.05	System Design Requirements .....	3
1.06	Quality Assurance.....	3
1.07	Submittals .....	5
1.08	Delivery, Storage And Handling.....	6
PART 2	PRODUCTS.....	6
2.01	Manufacturers / Suppliers.....	6
2.02	Materials .....	7
PART 3	EXECUTION.....	13
3.01	Examination .....	13
3.02	Preparation Of Soil Mixes .....	13
3.03	Preparation Of Sub-Grade.....	14
3.04	Placement Of Soil Mixes .....	14
3.05	Grading Of Soil Mixes.....	15
3.06	Clean Up .....	15

## GENERAL SPECIFICATION 02920 - SOIL MIXES

---

### 1.02 PAYMENT

- A. No separate payment will be made for performing any work of this Section and the Contractor shall include all costs thereof in its lump sum price bid for the Contract, except as provided for otherwise in the Detailed Specifications.

### 1.03 RELATED SECTIONS

- A. General Specification 02316 -- Excavation
- B. General Specification 02317 -- Backfilling
- C. General Specification 02371 -- Dust, Soil Erosion and Sedimentation Control
- D. General Specification 02910 -- Planting

### 1.04 REFERENCES

#### A. ASTM International (ASTM) Standards

- 1. ASTM D1556 -- Standard Test Method for Density and Unit Weight of Soil in Place by Sand Cone Method
- 2. ASTM D1557 -- Standard Test Methods for Laboratory Compaction Characteristics of Soil Using Modified Effort (56,000 ft-lbf/ft<sup>3</sup> (2,700 kN-m/m<sup>3</sup>))
- 3. ASTM D3385 -- Standard Test Method for Infiltration Rate of Soils in Field Using Double-Ring Infiltrimeters
- 4. ASTM D4318 -- Standard Test Methods for Liquid Limit, Plastic Limit and Plasticity Index of Soils
- 5. ASTM D6938 -- Standard Test Method for In-Place Density and Water Content of Soil and Soil-Aggregate by Nuclear Methods (Shallow Depth)
- 6. ASTM F1647 -- Standard Test Methods for Organic Matter Content of Athletic Field Rootzone Mixes

#### B. The Northeast Coordinating Committee for Soil Testing

- 1. NEC-1012 -- Recommended soil testing procedures for the Northeast United States, Northeastern Regional Publication Number 493

## GENERAL SPECIFICATION 02920 - SOIL MIXES

---

- C. The New York City Department of Health and Mental Hygiene
    - 1. Local Law 37 Pesticide Use by City Agencies – Pesticide Product Search <https://a816-healthpsi.nyc.gov/1137/ProductTestPesticide.aspx>
  - D. The New York State Pesticide Product, Ingredient and Manufacturer System (PIMS) <http://pmep.cce.cornell.edu/pims/index.html>
  - E. New York State Department of Environmental Conservation (NYSDEC)
    - 1. 6NYCRR Subpart 360-5, Composting Facilities
    - 2. 6NYCRR Subpart 375-6, Remedial Program Soil Cleanup Objectives
- 1.05 SYSTEM DESIGN REQUIREMENTS
- A. All soil mix components shall be tested and approved prior to incorporation into blended soil mixes.
  - B. Provide adequate quantities of all soil mix materials to attain, after compaction and natural settlement, all design-finished grades.
  - C. Sustainable Design Requirements
    - 1. Regional Materials: Soil shall be extracted within 250 miles of the project site, unless otherwise required in the Detailed Specifications.
  - D. Project-specific system design requirements will be provided in the Detailed Specifications, if necessary, to supplement requirements given herein or in the Contract Drawings.
- 1.06 QUALITY ASSURANCE
- A. Contractor shall submit written test reports as required in this Section.
    - 1. Testing shall be carried out by an independent testing laboratory.
    - 2. Engineer's approval of the testing laboratory shall be obtained by the Contractor before it is given any work of this Section.
    - 3. Contractor shall be responsible for timely submittal of samples to the testing laboratory.
  - B. Each test shall be carried out using the categories and sieve sizes as specified herein. Failure to include any of the required criteria will be sufficient cause for rejection of the test.
  - C. Each test report shall include the following information:
    - 1. Project title
    - 2. Name of Contractor
    - 3. Name of material supplier or location where material is extracted from
    - 4. Testing laboratory name, address and telephone number

## GENERAL SPECIFICATION 02920 - SOIL MIXES

---

5. Type of test
  6. Date of test
  7. Test results, including identification of deviations from acceptable ranges.
- D. Each sample shall be tested, as applicable, for the following:
1. Mechanical analysis: Sieve method, using sieve sizes specified.
  2. pH should be measured according to Recommended Soil Testing Procedures for the Northeastern United States (NEC-1012). Where soil will be used to support plant growth, lab analysis results must include corrective recommendations.
  3. Organic matter content: Percentage of oven-dry weight of soil, determined by loss on ignition of moisture-free sample, in accordance with Method A of ASTM F1647.
  4. Electrical conductivity (soluble salts): Test by saturated paste method in deciSiemens per meter (dS/m).
  5. Soil Fertility Analysis: Analysis for available macronutrients including, at a minimum, phosphorus and potassium in parts per million according to methods as specified in NEC-1012. Test methods and fertility recommendations must be included with results.
  6. Chemical Analyses of 6 NYCRR Part 375-6 compounds performed by a testing laboratory certified by the New York State Department of Health Environmental Laboratory Accreditation Program (NYSDOH-ELAP). The frequency of testing per volume of fill shall be:
    - a. 1 per 500 CY of material purchased from a registered/permited processing or recycling facility; or
    - b. 1 per 1000 CY of native materials (e.g., non-regulated soil and sand with no manmade materials) purchased from an operating gravel pit or similar facility.
- E. The Engineer may take and analyze at any time, such additional samples of materials as deemed necessary for verification of conformance to specification requirements. Contractor shall furnish samples for this purpose upon request and shall perform testing as requested at no additional cost to the City.
- F. No component bulk material for soil mix shall be used or blended into a mix, until test reports have been received and approved by the Engineer. As necessary, make any and all soil mix amendments and resubmit test reports indicating amendments, until approved.
- G. Comply with all rules, regulations, laws and ordinances of local, state and federal authorities having jurisdiction. Provide labor, materials, equipment and

## GENERAL SPECIFICATION 02920 - SOIL MIXES

---

services necessary for work to comply with such requirements at no additional cost to City.

- H. Procure and pay for all permits and licenses required for the Work of this Section.

### 1.07 SUBMITTALS

- A. The Contractor shall submit Shop Drawings and material specifications for the approval of the Engineer. Submittals shall include, but not be limited to:

1. Manufacturer's technical information, including application instructions where relevant, for all soil amendment materials required.
  - a. Fertilizers
  - b. Soil Inoculants
  - c. Herbicides
  - d. Water-absorbent Polymer
2. Samples of Soil Mix Components (1-pound package each):
  - a. Topsoil -- offsite imported material
  - b. Topsoil -- stripped from site
  - c. Compost
3. Samples of Blended Soil Mixes (1-pound package each):
  - a. Planting Mix
  - b. Lawn Mix
  - c. Aquatic/Marginal Mix
4. Test Results for Soil Mix Components (written report for each bulk component):
  - a. Topsoil -- offsite imported material
  - b. Topsoil -- stripped from site
  - c. Sand
  - d. Compost
5. Test Results for Blended Soil Mixes (written report for each blended soil mix):
  - a. Planting Mix
  - b. Lawn Mix
  - c. Aquatic/Marginal Mix

## GENERAL SPECIFICATION 02920 - SOIL MIXES

---

6. Sources and Manufacturers List: Submit a full list of sources and manufacturers of soil mixes, including component materials and soil amendments.
- B. Sustainable Design Submittals:
1. Regional Materials: Provide the following information:
    - a. Names of product and manufacturer
    - b. Material cost breakdowns. Cost breakdowns must include total material-only cost (excluding installation, labor and equipment).
    - c. Indicate the location and distance from the Project of material manufacturer and point of extraction, harvest, or recovery for each raw material. (For assemblies, include the percentage by weight that is considered regional.)
- 1.08 DELIVERY, STORAGE AND HANDLING
- A. Conform to all governmental regulations in regard to the transportation of materials to, from, and at the job site, and secure in advance such permits as may be necessary.
- B. Packaged Materials: Deliver packaged materials to the location where planting soil mixes are to be blended, in unopened bags or containers, each bearing the name and trademark of the producer, material composition, manufacturers' certified analysis, and the weight of the material.
1. All bags shall be protected from water and contamination with other materials.
  2. Retain packages for inspection by Engineer.
  3. All packaged materials shall be stored, handled and applied in strict accordance with manufacturer's instructions.
- C. Stockpiles
1. Each stockpile of bulk materials and soil mixes shall not exceed 50 cubic yards, and shall be no more than 6 feet in height, to prevent anaerobic conditions within the piles.
  2. All stockpiled materials shall be adequately handled as required in General Specification 02371 – Dust, Soil Erosion and Sedimentation Control.

## PART 2 PRODUCTS

### 2.01 MANUFACTURERS / SUPPLIERS

- A. Fertilizer shall be as manufactured by:
1. Osmocote®,

2. Meister®,
3. Or approved equal.

B. Other product manufacturers will be specified, if necessary in the Detailed Specifications.

2.02 MATERIALS

A. All materials furnished under the work of this Section shall conform to the following applicable requirements unless otherwise required in the Detailed Specifications, shown on the Contract Drawings, or directed in writing by the Engineer or the Engineer's Representative.

B. Topsoil - Offsite Imported Material

1. Imported topsoil or soil blends may not be mined from soils defined by the Natural Resources Conservation Service as prime farmland, unique farmland, or farmland of statewide importance. Imported topsoil shall be:
  - a. Of uniform quality, free from hard clods, stiff clay, hardpan, sods, roots, chips, sticks, partially disintegrated stone, cement, ashes, slag, concrete, tar residues, tarred paper, boards, or any other undesirable material. No topsoil shall be delivered in a frozen or muddy condition.
  - b. Free from refuse, material toxic or otherwise deleterious to plant growth, seeds, or other viable propagules of invasive plants. Construction and demolition debris as classified under 6 NYCRR Part 360, other than uncontaminated land clearing debris, shall not be used to amend topsoil.
  - c. Free of stones over 1 ½ inches in diameter, and will have less than 10 percent gravel.
2. Topsoil shall conform to the following requirements:
  - a. pH 5.5 to 7.0
  - b. Organic content 4 - 6%

## GENERAL SPECIFICATION 02920 - SOIL MIXES

---

3. Topsoil shall conform to the following mechanical analysis:

Sieve Size	Percent Passing
1"	100
1/4"	90 - 99
# 10	80 - 100
# 40	40 - 60
# 60	40 - 60
# 100	10 - 30
# 200	10 - 20

4. When the topsoil otherwise complies with the requirements of the specification but shows a deficiency of not more than one percent (1%) organic matter content; then humus, compost, or other approved organic matter may be incorporated when or as permitted by the Engineer.
5. Topsoil shall not contain hazardous waste, petroleum spills or other chemical releases, or industrial waste. Any shipment of topsoil that does not meet this requirement will be rejected by the Engineer and shall not be brought on site.
6. Topsoil being brought on site shall meet the lower of 6 NYCRR Part 375-6.8(b) Protection of Public Health – Residential and Protection of Groundwater SCOs, unless otherwise approved by the Engineer. Topsoil to be used in ecologically sensitive sites (e.g., wetlands) shall meet the SCOs for the protection of Ecological Resources, unless otherwise approved. See General Specification 02317 – Backfilling.

C. Topsoil - Stripped from Site

1. Reuse of topsoil stripped from site shall be used for this work when feasible, provided it meets:
- a. All the requirements of physical properties for imported topsoil as specified hereinbefore; and
  - b. The requirements for beneficial use of excavated soil as specified under 6NYCRR § 360-1.15(b). See General Specification 02317 -- Backfilling.
2. Use of topsoil stripped from site in this work may be as described further in the Detailed Specifications.



D. Compost

1. Shall conform to the following requirements:
  - a. Material shall be capable of sustaining the growth of vegetation, with no admixture of refuse or material toxic to plant growth.
  - b. Material shall be derived from organic wastes such as food and agriculture residues, composted cow or other animal manures, sewage sludge or other materials that meet the specified requirements.
  - c. Material shall be screened, and shall be free of any stones, branches, roots, brush, weeds, or wood chips, and all debris such as plastic fragments, glass, and metal fragments.
  - d. Organic content: 50% minimum.
  - e. pH: 5.5 to 8.0.
  - f. Carbon/nitrogen ratio: 25:1 to 35:1.
  - g. 100% passing 1/2" screen .
2. Compost shall meet the requirements for “Monthly Average Concentration” pollutant limits, except where the Engineer specifically allows the use of the “Maximum Concentration” pollutant limits, as stated in the current version of 6 NYCRR Part 360.
3. No compost shall be delivered until the approval of samples by the Engineer, but such approval does not constitute final acceptance. The Engineer reserves the right to reject, on or after delivery, any material which does not, in their opinion, meet these specifications. When compost is stored on the job, it shall be done as directed by the Engineer.
4. Certification: Only facilities permitted to compost biosolids under 6 NYCRR Part 360, will be allowed to furnish finished compost for use in topsoil. The certification shall be supplied by the Contractor prior to the delivery of any composted biosolids, topsoil containing sewage sludge, or other such regulated material to the site.

E. Soil Amendment Materials: Note that within the watershed, no fertilizers may be used in the absence of a soil test indicating a need for soil amendment. Recommended materials below may not be used except where they fulfill amendment requirements. Where authorized for use in the Drawings, Detailed Specifications or by written direction of the Engineer, Soil Amendment Materials shall have the following compositions:

1. Soil Fertility Analysis: Available macronutrients including Phosphorus and Potassium should be adequate to support the intended plant community. Available macronutrients shall not be at excessive levels

**GENERAL SPECIFICATION 02920 - SOIL MIXES**

---

that could potentially impair plant growth or impact water quality. The determination as to whether available nutrients are low, optimum, or excessive shall be made and reported by the soil testing laboratory based on extraction and test methods used.

- a. Only when soil analysis indicates a need and if approved in advance by the Engineer, apply commercial fertilizer and uniformly work in to top one inch of seedbed. The rate of application shall be determined by soil analysis.
  - b. Do not apply superphosphate except where specifically indicated and as approved by the Engineer. Where required, uniformly work in to top one inch of seedbed. The rate of application shall be determined by soil analysis.
2. In addition to obtaining the Engineer’s approval of the type(s) and N-P-K (Nitrogen-Phosphorus-Potassium) analyses of soil amendment materials, proposed based on soil test results, the Contractor shall meet the following requirements:
- a. Bonemeal: Shall be finely ground.
  - b. Commercial Fertilizer: A minimum of 50% of the nitrogen shall be derived from organic sources.
  - c. Controlled-release Fertilizer: Shall be in granular form.
3. Limestone: Shall be granular limestone, produced from Dolomitic limestone specifically for use in planting, with a minimum of 88% of calcium and magnesium carbonates, conforming to the following requirements:

Sieve Size	Percent Passing
# 10	100
# 20	90 minimum
# 100	60 minimum

4. Only when chemical analysis indicates a need and where approved by the Engineer, apply ground limestone and uniformly work in to top one inch of seedbed. The rate of limestone application shall be dependent on the pH of the soil, as determined by chemical analysis, and shall be as follows:

pH of Soil	Rate: Pounds/1000 Square Feet
5.0 to 5.5	100

**GENERAL SPECIFICATION 02920 - SOIL MIXES**

---

pH of Soil	Rate: Pounds/1000 Square Feet
5.5 to 6.0	50
6.0 to 6.8	25
over 6.8	0

- 5. Sulfur: Lower pH if required, by use of elemental sulfur product.
  - a. Peat moss or copper sulfate may not be used to lower pH.
- 6. Mycorrhizal Fungi Inoculant
  - a. For tree plantings, the Contractor shall supply Mycorrhizal Fungi Inoculant, if specified, in granular form such as by means of a three ounce (3 oz.) premeasured dry formulation packet, such as Mycor Tree Saver Transplant®, as manufactured by Plant Health Care, Inc., Pittsburgh, PA, or approved equal.
- 7. Water Retention Additive
  - a. Water Retention Additives for tree plantings shall be a granular polyacrylamide polymer of a potassium base and not a sodium base that slowly releases moisture into the root zone such as Terra Sorb, as manufactured by Plant Health Care, Inc., 440 William Pitt Way, Pittsburgh, Pa., or approved equal.
- F. Herbicides and Pesticides shall be in compliance with NYC Local Law 37 of 2005 and in conformance with the guidelines of NYC Department of Health for determining whether a pesticide or herbicide is prohibited by the Law.
- G. Planting Soil Mix
  - 1. Planting Mix shall conform to the following requirements:
    - a. Organic Matter: 4.5 % minimum
    - b. pH: 6.0 to 7.0
    - c. Electrical Conductivity (soluble salts): 0.7 to 2.0 dS/m
  - 2. Mix shall consist of the following proportions by volume:
    - a. Six parts topsoil
    - b. Two parts compost
  - 3. The following items shall be added to the above mix if specified in contract drawings or approved in writing by the Engineer:
    - a. Five pounds bonemeal per cubic yard of soil mixture
    - b. One pound commercial fertilizer per cubic yard of soil mixture

## GENERAL SPECIFICATION 02920 - SOIL MIXES

---

- c. One pound controlled release fertilizer per cubic yard of soil mixture
  - d. Two pounds water absorbent polymer per cubic yard of soil mixture, or as recommended by manufacturer
  - e. Ground limestone as required for specified pH
- H. Lawn Mix
- 1. Lawn Mix for all sodded, seeded and hydroseeded areas, shall conform to the following requirements:
    - a. Organic Matter: 4.5 % minimum
    - b. pH: 6.0 to 7.0
    - c. Electrical Conductivity (soluble salts): 0.7 to 4.0 dS/m
  - 2. Mix shall consist of the following proportions by volume:
    - a. Six parts topsoil
    - b. Two parts compost
    - c. Two parts sand
    - d. One part perlite
  - 3. The following items shall be added to the above mix if specified in contract drawings or approved in writing by the Engineer:
    - a. Five pounds bonemeal per cubic yard of soil mixture.
    - b. One pound commercial fertilizer per cubic yard of soil mixture.
    - c. One pound controlled release fertilizer per cubic yard of soil mixture.
    - d. Two pounds water absorbent polymer per cubic yard of soil mixture, or as recommended by manufacturer.
    - e. Ground limestone as required for specified pH
- I. Marginal/Aquatic Mix
- 1. Marginal Mix shall conform to the following requirements:
    - a. Organic Matter: 4 % minimum
    - b. pH: 6.0 to 7.0
    - c. Electrical Conductivity (soluble salts): 0.8 - 4.0 dS/m
  - 2. Mix shall consist of the following proportions by volume:
    - a. Four parts topsoil
    - b. One part clay

PART 3 EXECUTION

3.01 EXAMINATION

- A. Prior to soil mix placement, the Contractor shall examine the site to determine the status of construction and existing condition in and near the areas to be planted.
- B. The Contractor shall ascertain the location of all existing and proposed electric cables, conduits, irrigation, under-drainage systems and all other underground or at grade utilities, by contacting the appropriate utility company. The Contractor shall comply with the requirements of General Specification 02316 - Excavation prior to any excavation work.
  - 1. Contractor shall take proper precautions so as not to disturb or damage any sub-surface elements.
  - 2. Contractor shall be liable for and all damage to such utilities during the course of construction, and shall be responsible for making requisite repairs to damaged utilities at Contractor's own expense.
  - 3. Contractor shall be liable for any and all damage to surrounding areas caused by planting operations and shall be required to restore or replace damaged areas to original conditions, to the satisfaction of the Engineer.
- C. The Contractor shall comply with the requirements of General Specification 02371 - Dust, Soil Erosion and Sedimentation Control.
- D. The Contractor shall coordinate, adjust, and relate together, work of this Section with other work of the Project and with work of other Contractors. Such coordination shall include but not be limited to the following:
  - 1. Scheduling of planting operations
  - 2. Scheduling of maintenance operations
- E. The Contractor shall also:
  - 1. Verify that all work requiring access through or adjacent to areas where soil mixes are to be placed has been completed and no further access (other than landscape installation) will be required. In the event that access will be required, this must be coordinated with the Engineer.
  - 2. Perform soil mix blending and site soil work only during suitable weather conditions. Do not handle, haul, place, work, disc or rototill soil when frozen, excessively wet, or in otherwise unsatisfactory condition.

3.02 PREPARATION OF SOIL MIXES

- A. Excavation of subgrade shall conform to the applicable requirements of General Specification 02316 - Excavation.

## GENERAL SPECIFICATION 02920 - SOIL MIXES

---

- B. Uniformly blend all ingredients as required for each soil mix type, by wind rowing and/or tilling on a hard surfaced area.
  - 1. The components of all soil mixes shall be blended so that ingredients are thoroughly incorporated into the mixture to assure uniform distribution.
  - 2. Do not over-mix, mix shall remain friable and well aerated.
  - 3. Organic matter shall be maintained moist, not wet, during blending.
  - 4. Delay mixing of any approved fertilizers if planting will not follow within a few days.
  - 5. Add mycorrhizal fungi inoculant, if specified, to each tree planting at rate specified by approved manufacturer.
  - 6. Apply water retention additive as per approved manufacturer's instructions.

### 3.03 PREPARATION OF SUB-GRADE

- A. Verify as-constructed or existing sub-grade elevation and perform additional grading operations as necessary to bring the sub-grade to a true, smooth, slope parallel to the finished grade, at all areas to receive soil mixes.
- B. Any sub-grades or soils polluted by gasoline, oil, plaster, construction debris, unacceptable soils, or other substances which would render material unsuitable for plant growth, shall be removed from the premises, at no additional cost to the City, whether or not such pollution occurred or existed prior to or during the Contract period. In the event that such material is placed, this material shall be removed and replaced with approved material. All remedial operations associated with soil mixes shall be reviewed and approved by the Engineer.
- C. Clean sub-grade and dispose of all debris prior to placement of soil mixes.
  - 1. Remove all large clods, lumps, brush, roots, stumps, litter, trash, and other foreign material and stones one-half inch in diameter or larger.
  - 2. Dispose of removed material legally off-site in accordance with the applicable laws and regulations and the requirements for waste disposal under the Contract.
- D. Where specified in contract drawings or approved in writing by the Engineer, spray all vegetation on sub-grade with a pre-emergent weed killer at the rate of application recommended by the manufacturer.
- E. Protect adjacent pavements, walls, utilities and other construction from damage or staining by any soil mix placement operations.

### 3.04 PLACEMENT OF SOIL MIXES

- A. Do not place any muddy or wet Soil Mixes.

## GENERAL SPECIFICATION 02920 - SOIL MIXES

---

- B. Place and spread soil mix over sub-grade, to a depth sufficiently greater than the depth required for planting areas so that after settlement the completed work will conform to the lines, grades, and elevations shown or otherwise indicated.
  - C. Place and spread soil mix over the approved sub-grade, in 6-inch lifts, or as directed by Engineer, and settle to eliminate air pockets and minimize settlement. Lightly scarify previously placed surfaces prior to placing subsequent lifts.
  - D. Compact to 90% Modified Proctor, unless otherwise specified in the plans or Detailed Specifications
    - 1. Provide compaction testing to conform with the specified compaction density.
    - 2. Fills shall not be so compacted as to restrict the flow of air or water through the soil.
  - E. After completion of compaction operations, protect the installation from additional compaction from vehicular traffic, contamination by toxic materials or trash, and from water containing cement, clay, silt or any other materials.
  - F. Any soils that are over-compacted or contaminated after placement or otherwise made unsuitable for plant growth shall be removed from the premises and replaced with approved material or satisfactorily remediated at no additional cost to the City.
  - G. The Contractor shall also meet the applicable requirements on placement of soil mixes for different planting operations in General Specification 02910 – Planting.
- 3.05 GRADING OF SOIL MIXES
- A. After settlement has occurred, add soil to maintain finished grades. If for any reason soil is left exposed for a long duration prior to planting, add soil and regrade as required.
  - B. Protect placed soil mixes against construction activity with snow fencing or by other acceptable methods.
  - C. Protect from the eroding effects of wind and rain with filter fabric, as necessary.
- 3.06 CLEAN UP
- A. At the end of each work day the Contractor shall broom-clean the site, to remove all trash, debris, and loose soil materials.
  - B. Immediately following the completion of soil mix installation operations, the Contractor shall remove all excess materials, stock piles, waste material, tools and equipment, and leave the site in a clear and clean condition.

## GENERAL SPECIFICATION 02920 - SOIL MIXES

---

- C. All waste materials shall be disposed offsite by the Contractor in accordance with the applicable laws and regulations and the requirements for waste disposal under the Contract.

END OF SECTION



**SECTION 03100  
Concrete Formwork**

**PART 1 GENERAL**

**1.01 SECTION INCLUDES**

- A. The Work specified in this Section consists of designing, furnishing materials for, fabricating, erecting, and removing formwork, falsework and shoring for cast-in-place concrete as indicated on the Contract Drawings, specified and needed for a complete installation.
- B. The following index of this Section is included for convenience:

<u>Article</u>	<u>Title</u>	<u>Page</u>
		03100-
PART 1	GENERAL .....	1
1.01	Section Includes .....	1
1.02	Payment.....	2
1.03	Related Sections.....	2
1.04	References.....	2
1.05	Submittals .....	2
1.06	Quality Assurance And Qualifications .....	3
1.07	Product Delivery, Storage, And Handling .....	4
1.08	Field Measurements .....	4
1.09	Job Conditions .....	5
PART 2	PRODUCTS.....	5
2.01	Manufacturers .....	5
2.02	Lumber .....	5
2.03	Plywood .....	6
2.04	Steel Forms .....	6
2.05	Form Ties.....	7
2.06	Chamfer Strips .....	7
2.07	Inserts.....	7
2.08	Dovetail Anchor Slots.....	7
2.09	Shop Fabricated Forms .....	7
2.10	Form Caulking .....	8
2.11	Form Release Agent.....	8
2.12	Form Film .....	8
2.13	Form Liners.....	8
2.14	RusticationS .....	8
PART 3	EXECUTION.....	8
3.01	Preparation .....	8
3.02	Erection And Installation .....	9
3.03	Protection .....	11
3.04	Reshoring .....	11

## GENERAL SPECIFICATION 03100 - CONCRETE FORMWORK

---

3.05	Removal Of Forms And Ties .....	12
3.06	Re-Use Of Forms .....	13

### 1.02 PAYMENT

- A. Unless otherwise provided in the Detailed Specifications, no separate payment will be made for performing any Work required under this Section and the Contractor shall include all costs therefore in its lump sum price bid for the Contract.

### 1.03 RELATED SECTIONS

- A. General Specification 03300 - Cast-in-Place Concrete.
- B. General Specification 03350 - Concrete Finishes.

### 1.04 REFERENCES

- A. ASTM A 36 - Carbon Structural Steel.
- B. ACI 117 - Standard Tolerances for Concrete Construction and Materials.
- C. ACI 303 - Guide to Cast-in-Place Architectural Concrete Practice.
- D. ACI 318 - Building Code Requirements for Structural Concrete.
- E. ACI 347 - Guide to Formwork for Concrete.
- F. ACI SP-4 - Formwork for Concrete.
- G. New York City Building Code.
- H. American Plywood Association (APA): APA Grade - Trademark.
- I. U.S. Department of Commerce Product Standards: PS-1-74 for Construction and Industrial Plywood.
- J. Western Wood Products Association: WWPA Catalog Use Product Manual.

### 1.05 SUBMITTALS

- A. Submit Shop Drawings and other data for approval of the Engineer. Submittals shall include, but not be limited to:
  - 1. Design of all field-constructed and prefabricated formwork.
  - 2. For each type of form required, material type, material thickness, finish, and a dimensional cross-sectional profile.
  - 3. Details of erection, including various connections, layouts of form units placement directions, anchoring and support details, attachment of accessories, each condition requiring enclosures, cut opening, special jointing, and other accessories as required to complete the work.
- B. Manufacturer's specifications and installation instructions for each type of required formwork and accessory shall be submitted. These include each type of sheeting, chamfer strips, form facing materials, form ties, form liners, rustication strips, form

release agent, dovetail anchor slots, form coating material, form caulking, and similar items.

C. Plan of Reshoring.

1.06 QUALITY ASSURANCE AND QUALIFICATIONS

A. Formwork shall be designed and constructed in compliance with ACI SP-4 and ACI 303.

B. Design of Formwork:

1. The Contractor shall assume responsibility for the design, engineering and construction of formwork. Forms shall be designed to produce concrete members identical in shape, lines and dimensions to members shown on the Contract Drawings.

2. The formwork shall be designed for the loads and lateral pressures in accordance with ACI 347 and wind loads as specified by the New York City Building Code.

3. Construction and control joints, openings, offsets, keyways, recesses, moldings, chamfers, blocking, screeds, bulkheads, waterstops, anchorages, inserts, and other features shall be provided as required.

4. Formwork shall be designed to be readily removable without impact, shock, or damage to 'green' concrete surfaces and adjacent materials.

5. The maximum deflection of facing materials reflected in concrete surfaces exposed to view shall be 1/240 of the span between structural members. The formwork shall be cambered to compensate for anticipated deflections in the formwork due to the weight and pressure of the fresh concrete and due to construction loads.

6. Formwork surface materials shall meet the requirements of General Specification 03350 - Concrete Finishes.

C. Unless otherwise specified in the Detailed Specification, formwork shall be constructed so that the concrete surfaces will conform to the tolerance limits as given in ACI 117.

D. A full size mock-up of a cast-in-place wall shall be erected on the site where directed. Mock-up shall conform to requirements of General Specification 03350 - Concrete Finishes.

E. Shop Drawings reviews shall be obtained before custom fabrication is started and before delivery of materials to the project site.

F. Work of this Section shall be coordinated with the work of other trades so that construction is not delayed.

## GENERAL SPECIFICATION 03100 - CONCRETE FORMWORK

---

- G. Formwork erection procedures and health and safety of the work force shall be the responsibility of the Contractor. The requirements of authorities having jurisdiction shall be complied with.
- H. Errors of detailing and fabrication and the correct fit of the formwork shall be the responsibility of the Contractor.
- I. Materials, fabrications and workmanship found defective shall be promptly removed and replaced and new acceptable work shall be provided in accordance with Contract requirements at no additional expense to the City.
- J. Design of formwork layout, spans, fastenings, joints, and framed openings shall be under the direct supervision of a Professional Engineer, who is licensed and registered in the State of New York and experienced in structural design of formwork.

### 1.07 PRODUCT DELIVERY, STORAGE, AND HANDLING

- A. Materials shall be delivered to the site in an undamaged condition and at such intervals as will avoid delay in the work.
- B. Material shall be stored and protected in a clean, properly drained location. Material shall be kept off the ground under a weather-tight covering permitting good air circulation. Formwork materials shall be stored on dry wood sleepers, pallets, platforms or other appropriate supports which have slope for positive drainage. Materials shall be protected from distortion, excessive stresses, corrosion and other damage. Materials shall not be stored on the structure in a manner that might cause distortion or damage to the supporting structure. The maximum uniform distributed storage load shall not exceed 20 pounds per square foot.
- C. Material shall be handled safely in a manner that will prevent distortion or other damage. Care shall be exercised at all times to avoid damage through careless handling during unloading, storing and erecting. Panels shall be supported by using strong backs while lifting panels in a horizontal position.

### 1.08 FIELD MEASUREMENTS

- A. Prior to commencement of the Work, existing dimensions, elevations, locations and conditions applicable to the Work shall be field verified. Variances and discrepancies from the Contract Drawings and potential interferences shall be reported promptly to the Engineer.
- B. Sufficient field measurements shall be taken prior to preparation of Shop Drawings and fabrication of construction materials, where possible, to ensure proper fitting of the work. However, job progress shall not be delayed. The Contractor shall allow for adjustments and fittings wherever the taking of field measurements before fabrication may not be possible or might delay the work.
- C. Actual field-verified conditions may require modifications to the fabrication and/or erection details as indicated on the Contract Drawings. The Work shall be performed to meet actual field conditions encountered.

## GENERAL SPECIFICATION 03100 - CONCRETE FORMWORK

---

### 1.09 JOB CONDITIONS

- A. Formwork materials shall be protected before, during and after erection to insure acceptable finished concrete Work. In-place materials and other operations of work in connection with concrete pours shall be protected.
- B. In the event of damage to erected forms, necessary repairs or replacements prior to concrete pours shall be performed at no expense to the City.
- C. The Contractor shall allow sufficient time, as determined by the Engineer from the approved schedule, between erection of forms and placing of concrete for the various trades to properly install their Work.
- D. External or superimposed loads, lateral or vertical, shall not be applied on casting concrete until concrete has developed specified 28-day compressive strength and a minimum age of 14-days.
- E. Stay-in-place forms are not permitted unless otherwise shown on the Contract Drawings.

### PART 2 PRODUCTS

#### 2.01 MANUFACTURERS

- A. A-2 Cone Snap-in Form Tie shall be as manufactured by:
  - 1. Dayton Superior.
  - 2. Williams Form Engineering Corp.
  - 3. Symons Corp.
  - 4. Or approved equal.
- B. Form caulking shall be as manufactured by:
  - 1. Series 1200 Construction Caulking; GE Silicones/Momentive Performance Materials, Inc., Waterford, NY.
  - 2. Dow Corning 999-A; Dow Corning Co., Auburn, MI.
  - 3. Or approved equal.
- C. Form release agent shall be as manufactured by:
  - 1. Specco F-100; Specco Industries, Inc., Lemont, IL.
  - 2. Debond Form Coating; L&M Construction Chemicals, Inc., Omaha, NE.
  - 3. Magic Kote; Symons Corporation, Des Plaines, IL.
  - 4. Or approved equal.
- D. Form film shall be as manufactured by:
  - 1. Symons Corporation, Des Plaines, IL.
  - 2. Or approved equal.

## GENERAL SPECIFICATION 03100 - CONCRETE FORMWORK

---

- E. Form liners shall be as manufactured by:
  - 1. Dura-Tex; Symons Corporation, Des Plaines, IL.
  - 2. Or approved equal.
- F. Rustications shall be as manufactured by:
  - 1. Symons Corporation, Des Plaines, IL.
  - 2. Or approved equal.

### 2.02 LUMBER

- A. Only stress-grade lumber shall be provided. Form framing, sheathing and shoring shall conform to WWPA Catalog A.
- B. For lumber in contact with concrete, the lumber shall be provided with dressed or tongue-and groove edges on at least the side contacting the concrete, unless otherwise indicated on the Contract Drawings.

### 2.03 PLYWOOD

- A. Only grade-marked plywood conforming to APA shall be provided.
- B. B-B Plyform, Exterior Class 1 or 2, or High Density Overlay (HDO) form plywood, Class 1 or 2 conforming to U.S. Product Standard PS-1 shall be provided.
- C. Thickness shall be as required to maintain alignment and surface smoothness, but not less than 5/8 inch thick.

### 2.04 STEEL FORMS

- A. Commercial grade sheets not less than 16 gage shall be provided.
- B. Steel forms in rust-free condition shall be maintained by use of steelwool and light grinding, followed by coats of the specified release agent.
- C. Stock material that is free from warps, bends, kinks, cracks, and rust or other matter that could stain the concrete shall be provided.
- D. Panels shall be fabricated in conformance with the approved submittals.
- E. Outward facing surfaces shall be reinforced as required to prevent warpage and deformation during concrete placement.

### 2.05 FORM TIES

- A. Commercially manufactured type form ties, hangers, and clamps of such type that, after removal of the forms, metal will not be closer than concrete cover as indicated on the Contract Drawings from concrete surface shall be provided. Non-fabricated wire ties will not be permitted.
- B. A cone-shaped, snap-in type form tie suitable for the intended use with a working load as required and an integral hot forged head shall be provided.

- C. Ties with swaged washers or other suitable devices to prevent seepage of fluid along the ties shall be provided. Ties shall be left in place. She-bolt with water seals shall be provided.
  - D. Form ties for all liquid-retaining structures shall have waterstop at mid-thickness of wall.
  - E. Lugs, cones, washers, or other devices which do not leave holes or depressions greater than 1-inch in diameter shall be provided.
- 2.06 CHAMFER STRIPS
- A. 3/4 inch by 3/4 inch triangular fillets shall be provided, all of which shall be milled from clear, straight-grain pine, surfaced each side, or all of which shall be extruded vinyl type with or without nailing flange unless otherwise indicated on the Contract Drawings.
- 2.07 INSERTS
- A. Galvanized cast steel or galvanized welded steel inserts, complete with anchors to concrete and fittings such as bolts, wedges and straps shall be provided.
- 2.08 DOVETAIL ANCHOR SLOTS
- A. Dovetail anchor slots manufactured from 22 gage, electro-galvanized steel with removable felt or polyurethane filler shall be provided, where indicated on the Contract Drawings.
- 2.09 SHOP FABRICATED FORMS
- A. Forms shall be fabricated in accordance with the approved submittals.
  - B. Forms shall be maintained clean, smooth, and free from imperfections and warpage.
  - C. Locate joints as indicated on the approved Shop Drawings.
    - 1. Form panels shall be arranged in symmetrical patterns conforming to the general lines of the structure.
    - 2. Except when otherwise indicated on the Contract Drawings, panels on vertical surface shall be oriented with the long dimension horizontal joints level and continuous.
    - 3. Form panels on each side of the panel joint shall be precisely aligned by means of fasteners common to both panels, to result in a continuous, unbroken concrete surface.
    - 4. Largest stock size practicable shall be provided.
    - 5. Between form joints, areas less than the stock size of the form liner material shall be lined with a single piece of liner material.

2.10 FORM CAULKING

- A. Form caulking shall be a one-component, gun-grade silicone sealant that is capable of producing flush, watertight and non-absorbent surfaces and joints. Sealant shall be compatible with the type of forming material and concrete ingredients used.

2.11 FORM RELEASE AGENT

- A. Form release agent shall be a VOC compliant commercial formulation form-coating compound that will not bind with, stain, nor adversely affect concrete surfaces, and will not impair subsequent treatment of concrete surfaces requiring bond or adhesion, nor impede wetting of surfaces to be cured with water or curing compounds. Form release agent shall be a nonreactive type as approved by ANSI/ASF.

2.12 FORM FILM

- A. Form film shall conform to the requirements of Paragraph 2.11.A.
  - 1. Thinner shall be provided as recommended by manufacturer of the form film.

2.13 FORM LINERS

- A. Form liners shall be provided as indicated in the Detailed Specifications and/or on the Contract Drawings.

2.14 RUSTICATIONS

- A. Rustications shall be provided as indicated in the Detailed Specifications and/or the Contract Drawings.

**PART 3 EXECUTION**

3.01 PREPARATION

- A. The Contractor shall examine the areas and conditions under which the Work of this Section is to be performed. Conditions detrimental to the proper and timely completion of the Work shall be corrected. Work shall not proceed until unsatisfactory conditions have been corrected. Prior to placement of concrete, forms shall be inspected for cleanliness and accuracy of alignment.
- B. Earth cuts shall not be used as forms for vertical surfaces, unless shown on the Contract Drawings or specified in the Detailed Specification.
- C. Where different levels are indicated for wall footings, the footings shall be stepped. Unless otherwise indicated on the Contract Drawings, steps in wall footings shall not be of greater height than the thickness of the footings and steps shall not lap less than 6 inches. No form shall be set at the back of such steps and where earth has slumped off in such locations it shall be cut back to a vertical plane just before the concrete is placed.



3.02 ERECTION AND INSTALLATION

- A. Forms shall be constructed in accordance with ACI 347 to required dimensions, plumb, straight and mortar tight, and all joints and seams shall be made mortar-tight. Forms shall be substantial, properly braced, and tied together to maintain position and shape and to resist all pressures to which they may be subject. Unless otherwise indicated on the Contract Documents, formwork shall be constructed so that the concrete surfaces will conform to the tolerance limits in ACI 117.
- B. The size and spacing of studs and wales shall be determined by the nature of the work and the height to which concrete is placed. Forms shall be made adequate to produce true, smooth surfaces.
- C. Forms shall be supplied for repeated use in sufficient number to ensure the required rate of progress. Forms shall be cleaned and inspected immediately prior to depositing concrete. Deformed, broken or defective forms shall be removed from the work.
- D. Joints shall be snug and tight and shall occur only at the designated locations. Construction and control joints other than those shown on the Contract Drawings shall be approved by the Engineer. Horizontal joints shall be level, and vertical joints shall be plumb. Joints shall be made perpendicular to the main reinforcement except where otherwise indicated on the Contract Drawings.
- E. Temporary openings shall be provided where interior area of formwork is inaccessible for cleanout or inspection before concrete placement, and for placement of concrete. Temporary openings shall be securely braced and set tightly to forms to prevent the loss of concrete mortar. Temporary openings shall be located on forms in locations as inconspicuous as possible consistent with the requirements of the work.
- F. Openings shall be provided in concrete formwork of the correct size and in the proper location to accommodate other operations of construction work in the project. Expansion joint material, waterstops, and other embedded items to be built into forms shall be accurately placed and securely supported against displacement. Voids in sleeves, inserts, and anchor slots shall be filled temporarily with readily removable material to prevent the entry of concrete into the voids.
- G. Edge forms or bulkheads and intermediate screed strips for slabs shall be set to obtain required elevations and contours in the finished slab surface.
- H. Forms shall be set sufficiently to prevent joints in wood forms from opening prior to concrete pour.
- I. Cutting form ties back from the face of the concrete shall not be permitted.
- J. Formwork shall be observed continuously while concrete is being placed to see there are no deviations from desired elevation, alignment, plumbness and camber. If, during casting, weakness develops and the formwork shows settlement,

## GENERAL SPECIFICATION 03100 - CONCRETE FORMWORK

---

deflection or distortion, the Work shall be stopped, improperly cast concrete shall be removed and the formwork shall be reconstructed to perform properly.

1. Forms for columns, beams, girders, walls and window openings shall be erected in accordance with ACI 117, with a maximum camber of 3/4-inch in 20 feet. Column sides shall be clamped with metal column clamps, or equal, spaced according to manufacturer's recommendation. Exposed external angles of columns, beams, girders and walls, except where specially shown on the Contract Drawings shall be provided with 3/4-inch bevel strips securely nailed on all concrete formwork including concrete encasement of structural steel shapes.
- K. Form release agents shall be applied in accordance with manufacturer's instructions and as specified herein:
1. Form contact surfaces shall be coated with form release agent compound before reinforcement is placed. Excess form release agent material shall not be allowed to accumulate in the forms or to come into contact with surfaces which are required to be bonded to fresh concrete such as concrete reinforcement and embedded items.
  2. Steel forms shall be coated with non-staining, rust-preventive form oil or otherwise shall be protected against rusting. Rust-stained steel surfaces in contact with concrete shall not be used.
- L. Excess form coating material shall not be allowed to accumulate in the forms.
- M. Form coatings shall not be allowed to come in contact with construction joints or reinforcing steel.
- N. Runways for moving equipment shall be provided with struts or legs and supported directly on the formwork or structural member without resting on the reinforcing steel.
- O. Wood forms shall be constructed for wall openings to facilitate loosening and to counteract swelling of the forms.
- P. All sleeves, inserts, anchors, and embedded items required for adjoining work or for support of joining work shall be placed prior to concreting.
- Q. Architectural Formwork:
1. Form liners and rustication strips shall be installed in strict accordance with the manufacturer's written instructions and recommendations. The ends of the form liner pattern shall be clogged and all form joints and edges shall be taped using 1/8-inch thick by 3/4-inch wide foam tape centered on the joints, then caulked in accordance with the manufacturer's recommendations each time forms are set. A representative of the manufacturer shall be present at the site to supervise the installation of the form liner for the entire project.

2. Forms for smooth concrete shall be installed in such a manner that there will be no horizontal form joints, and the forms shall be aligned so that vertical joints occur only at "V-Groove" rustications. Form ties shall be spaced in a uniform pattern vertically and horizontally. Form ties shall be positioned in smooth concrete bands and in panels between "reveal" rustications, if any.
3. Beam and girder soffits shall be erected in accordance with ACI 117 and sufficiently braced, shored, and wedged to prevent deflection. Column sides shall be clamped in accordance with this specification with metal column clamps, spaced according to the manufacturer's directions.

3.03 PROTECTION

- A. During installation, the forms shall not be used as a storage platform nor as a working platform until the forms have been permanently fastened in position.
- B. The surface of installed forms shall not be overloaded.

3.04 RESHORING

- A. When reshoring is permitted or required, the operations shall be planned in advance and in accordance with acceptable procedures. The Contractor shall submit as a part of the shop drawings a Plan for Reshoring prepared and sealed by a New York State registered professional engineer.
- B. During reshoring the concrete in beams, slabs, columns, or any other structural members shall not be loaded with combined dead and construction loads in excess of the loads permitted by the Engineer for the developed concrete compressive strength at the time of reshoring.
- C. Reshores shall be placed after stripping operations are complete but in no case later than the end of the working day on which stripping occurs.
- D. Reshoring for the purpose of early form removal shall be performed so that at no time will large areas of new construction be required to support their own weight. While reshoring is under way, no live loads shall be permitted on the new construction. Reshores shall be tightened to carry their required loads but they shall not be overtightened so that the new construction is overstressed. Reshores shall remain in place until the concrete has reached its specified 28-day strength, unless otherwise specified.
- E. For floors supporting shores under newly placed concrete, the original supporting shores or reshores shall be left in place. The shoring or reshoring system shall have a capacity sufficient to resist the anticipated loads and in all cases shall have a capacity equal to at least one-half of the capacity of the shoring system above. Reshores shall be located directly under the floors supporting shores unless other locations are permitted or shown on the Contract Drawings.
- F. In multi-story buildings reshoring shall be extended over a sufficient number of stories to distribute the weight of newly placed concrete, forms, and construction

**GENERAL SPECIFICATION 03100 - CONCRETE FORMWORK**

---

live loads so the design superimposed loads of the floors supporting shores are not exceeded.

**3.05 REMOVAL OF FORMS AND TIES**

- A. Forms shall be removed in accordance with ACI 347 recommendations without damage to concrete and in a manner to insure complete safety to the structure. Forms, form ties and bracing shall not be removed without specific permission of the Contractor's Registered Professional Engineer.
- B. Top forms on sloping surfaces of concrete shall be removed as soon as removal operations will not allow the concrete to sag. Any needed repairs or treatment required on sloping surfaces shall be performed at once and shall be followed immediately with the specified curing.
- C. Upon removal of forms, the Engineer shall be notified in order that a review of the newly stripped surfaces may be made before patching.
- D. Wood forms for wall openings shall be loosened without causing damage to the concrete. The face of concrete shall not be pried against. Only wooden wedges shall be used.
- E. Whenever the formwork is removed during the curing period, the exposed concrete shall be cured in accordance with one of the methods specified in General Specification 03300 - Cast-in-Place Concrete.
- F. In general, forms shall not be removed until the concrete has hardened sufficiently to safely support its own load, plus any superimposed load that might be placed thereon. As a minimum the forms shall be left in place for length of time specified below. These times represent cumulative days, not necessarily consecutive, during which the air surrounding the concrete is above 50°F.

	<b>Min Time (days)</b>	<b>Min Strength (psi)</b>
1. Curbs and Walks	2	1500
2. Columns	2	2000
3. Side forms for girders and beams	2	2000
4. Walls	2	2000
5. Bottom forms of slabs:		
a. Under 20 feet clear span	7	3000
b. Over 20 feet clear span	10	3500
6. Bottom forms of beams and girders:		
a. Under 20 feet clear span	7	3000

**GENERAL SPECIFICATION 03100 - CONCRETE FORMWORK**

---

	<b>Min Time (days)</b>	<b>Min Strength (psi)</b>
b. Under 20 feet clear span	14	3500
c. Under 20 feet clear span	21	4000

1. These times shall be increased if the concrete temperature following placement is permitted to drop below 50°F.

G. Care shall be taken in removing forms, wales, shlings, supports and form ties to avoid spalling or marring the concrete. Rubbed finish, if required, and such patching as may be necessary shall be started immediately after removal.

3.06 RE-USE OF FORMS

A. Forms for re-use shall meet requirements for new forms with respect to effect on cast-in-place concrete appearance and structural stability.

B. Re-use of forms shall in no way delay or change the concrete placement schedule as compared to the schedule obtainable if all forms were new (in the case of wood forms) or if the total required forms were available (in the case of metal forms).

C. Formwork shall be cleaned and re-oiled prior to re-use. Plywood forms shall not be re-used if unused holes from form ties exist from a previous use. High density overlay plywood panels shall be thoroughly cleaned and lightly recoated before each additional use. Wood forms shall not be used more than three times.

END OF SECTION

**GENERAL SPECIFICATION 03100 - CONCRETE FORMWORK**

---

NO TEXT ON THIS PAGE

**GENERAL SPECIFICATION 03210 - REINFORCING STEEL**

---

**SECTION 03210  
Reinforcing Steel**

**PART 1 GENERAL**

**1.01 SECTION INCLUDES**

- A. The Contractor shall furnish and install all reinforcing steel as indicated on the Contract Drawings including all cutting, bending, fastening and any special work necessary to hold the reinforcing steel in place and protect it from injury and corrosion in accordance with the requirements of this Section.
- B. An index of the Articles in this Section is presented hereinafter for the convenience of the Contractor.

<u>Article</u>	<u>Title</u>	<u>Page</u> 03210-
PART 1	GENERAL.....	1
1.01	Section Includes.....	1
1.02	Related Sections.....	2
1.03	Measurement And Payment.....	2
1.04	References.....	3
1.05	General Requirements.....	4
1.06	Testing.....	5
1.07	Submittals.....	5
1.08	Delivery, Storage And Handling.....	6
PART 2	PRODUCTS.....	6
2.01	Reinforcement.....	6
2.02	Wire Bar Supports.....	8
2.03	Coated Wire Reinforcement Supports.....	9
2.04	Precast Concrete Reinforcement Supports.....	9
2.05	Welding.....	9
2.06	Dowel Adhesive System.....	9
2.07	Temperature Reinforcing.....	10
PART 3	EXECUTION.....	10
3.01	Fabrication.....	10
3.02	Placing.....	11
3.03	Bending Of Bars.....	13
3.04	Preheating Of Bars.....	14
3.05	Splicing.....	14
3.06	Dowel Adhesive System Installation.....	15
3.07	Miscellaneous Installation Requirements.....	15
3.08	Inspection.....	16

## GENERAL SPECIFICATION 03210 - REINFORCING STEEL

---

### 1.02 PAYMENT

#### A. Payment:

1. Unless otherwise specified in the Detailed Specifications, no separate payment will be made for performing any Work required under this Section and the Contractor shall include all costs thereof in its lump sum price bid for the Contract.

#### B. Measurement: Measurement requirements by weight, if applicable to the Contract, shall be in accordance with the following:

1. The quantity in pounds, to be measured for payment, shall be the total weight of reinforcing bars and reinforcing mesh incorporated in the work in conformity with the approved Shop Drawing.

2. The total weight of reinforcing bars will be determined by the Engineer using the bar length and sizes shown on the approved Shop Drawing, and the unit weight for the bar sizes in accordance with the ASTM specified in the Detailed Specifications.

3. The average unit weights of reinforcing mesh will be determined by the Engineer, using the actual weights of areas of not less than 30 square feet, and such average unit weights will be used in determining the total weight of reinforcing mesh.

4. The weight of wire, clips, ties, spacers or other fastening devices will not be measured for payment.

### 1.03 RELATED SECTIONS

A. General Specification 03300 - Cast-In-Place Concrete.

B. General Specification 03410 - Precast Structural Concrete

C. General Specification 03450 - Precast Architectural Concrete

### 1.04 REFERENCES

A. ASTM A82 - Steel Wire, Plain, for Concrete Reinforcement.

B. ASTM A184 - Fabricated Deformed Steel Bar Mats for Concrete Reinforcement.

C. 1064 - Steel Welded Wire Fabric, Plain, for Concrete Reinforcement.

D. ASTM A496 - Steel Wire, Deformed, for Concrete Reinforcement.

E. ASTM A497 - Steel Welded Wire Fabric, Deformed, for Concrete Reinforcement.

F. ASTM A615 - Deformed and Plain Billet-Steel Bars for Concrete Reinforcement.



## GENERAL SPECIFICATION 03210 - REINFORCING STEEL

---

- G. ASTM A616 - Rail-Steel Deformed and Plain Bars for Concrete Reinforcement.
  - H. ASTM A617 - Axle-Steel Deformed and Plain Bars for Concrete Reinforcement.
  - I. ASTM A706 - Low-Alloy Steel Deformed Bars for Concrete Reinforcement.
  - J. ASTM A767 - Zinc-Coated (Galvanized) Steel Bars for Concrete Reinforcement.
  - K. ASTM A775 - Epoxy-Coated Reinforcing Steel Bars.
  - L. ACI 315 - Manual of Standard Practice for Detailing Reinforced Concrete Structures.
  - M. ACI 318 - Building Code Requirements for Reinforced Concrete.
  - N. ACI SP66 - Detailing Manual.
  - O. ANSI/AWS D1.4 - Structural Welding Code - Reinforcing Steel.
  - P. CRSI DA4 - Concrete Reinforcing Steel Institute Manual of Standard Practice.
  - Q. New York City Building Code.
- 1.05 GENERAL REQUIREMENTS
- A. Placing drawings showing all dimensions necessary for fabrication and placing of the reinforcing steel and accessories without reference to the project drawings shall be submitted for approval. Approval shall be obtained from the Engineer before fabrication.
  - B. Details of concrete reinforcement not covered on the Contract Drawings, the Detailed Specifications or herein shall be in accordance with ACI 315, ACI 318 and CRSI DA4.
  - C. When it is found necessary to move reinforcement beyond the specified placing tolerances to avoid interference with other reinforcement, conduits, or embedded items, a submittal showing the resulting arrangement of reinforcement shall be submitted to the Engineer for approval.
  - D. All reinforcement, at the time concrete is placed, shall be free of mud, oil or other materials that may adversely affect or reduce the bond. Reinforcement with rust, mill scale or a combination of both shall be considered satisfactory provided the minimum dimensions, weight and height of deformation of a hand-wire-brushed test specimen are not less than the applicable ASTM specification requirement.
  - E. All reinforcement shall be supported and fastened before concrete is placed and shall be secured against displacement within the tolerances permitted in Article 3.01D.

## GENERAL SPECIFICATION 03210 - REINFORCING STEEL

---

- F. Templates shall be furnished for placement of all column dowels unless otherwise permitted by the Detailed Specifications.
- G. All splices shall be as indicated on the Contract Documents unless otherwise permitted by the Engineer. Mechanical connections that provide a minimum of 125 percent of the yield strength of the reinforcing bars may be used when permitted by the Engineer.
  - 1. Reinforcement coating shall be removed in the area of the mechanical connection, if so required by the connection manufacturer.
  - 2. After installation of mechanical connections on zinc-coated (galvanized) or epoxy-coated reinforcing bars, coating damage shall be repaired in accordance with the requirements of this Section. All external parts of mechanical connections used on coated bars, including steel splice sleeves, bolts and nuts shall be coated with the same material used for repair of coating damage.

### 1.06 TESTING

- A. If required by the Detailed Specifications, the Contractor shall provide samples from each load of reinforcing steel delivered in a quantity adequate for testing. Costs of testing will be paid for as provided in the Detailed Specifications.
- B. If required by the Detailed Specifications, the Contractor shall provide samples of each type of welded splice used in the work in a quantity and of dimensions adequate for testing. At the discretion of the Engineer, radiographic testing of direct butt welded splices will be performed. The Contractor shall provide assistance necessary to facilitate testing. The Contractor shall repair any weld which fails to meet the requirements of ANSI/AWS D1.4. Costs of testing will be paid for as provided in the Detailed Specifications.

### 1.07 SUBMITTALS

- A. The Contractor shall submit placing drawings, Shop Drawings and material specifications for the approval of the Engineer. Submittals shall include, but not limited to:
  - 1. Detailed placing and shop fabricating drawings, prepared in accordance with ACI 315 and ACI SP66 shall be furnished for all concrete reinforcing. These drawings shall be made to such a scale as to clearly show joint locations, openings, and the arrangement, spacing and splicing of the bars.
  - 2. Certified copies of mill reports shall accompany all deliveries of reinforcing steel.
  - 3. Description of the reinforcing steel manufacturer's marking pattern.
  - 4. Description of proposed supports for each type of reinforcing.
  - 5. Description of reinforcing weld locations and weld procedures.

## GENERAL SPECIFICATION 03210 - REINFORCING STEEL

---

- B. The Contractor shall also include the following:
1. Requests to relocate any bars that cause interferences or that cause placing tolerances to be violated.
  2. Request to use splices not shown on the Contract Drawings.
  3. Request to use mechanical couplers along with manufacturer's literature on mechanical couplers with instructions for installation, and certified test reports on the couplers' capacity.
  4. Request for placement of column dowels without the use of templates.
  5. Request and procedure to field bend or straighten partially embedded reinforcing.

### 1.08 DELIVERY, STORAGE AND HANDLING

- A. All reinforcing shall be neatly bundled and tagged for placement when delivered to the job site. Bundles shall be properly identified for coordination with mill test reports.
- B. Coating damage zinc-coated (galvanized) reinforcing bars due to handling, shipping and placing shall be repaired in accordance with the requirements of this Section.
- C. Equipment for handling epoxy-coated reinforcing bars shall have protected contact areas. Bundles of coated bars shall be lifted at multiple pickup points to prevent bar-to-bar abrasion from sags in the bundles. Coated bars or bundles of coated bars shall not be dropped or dragged. Coated bars shall be stored on protective cribbing. Coating damage due to handling, shipping and placing shall be repaired in accordance with the requirements of this Section.
- D. Reinforcing steel shall be stored above ground on platforms or other supports and shall be protected from the weather at all times by suitable covering. It shall be stored in an orderly manner and plainly marked to facilitate identification.
- E. Reinforcing steel shall at all times be protected from conditions conducive to corrosion until concrete is placed around it.
- F. The surfaces of all reinforcing steel and other metalwork to be in contact with concrete shall be thoroughly cleaned of all dirt, grease, loose scale and rust, grout, mortar and other foreign substances immediately before the concrete is placed. Where there is delay in depositing concrete, reinforcing shall be reinspected and if necessary recleaned.

## PART 2 PRODUCTS

### 2.01 REINFORCEMENT

- A. Reinforcing Steel:

## GENERAL SPECIFICATION 03210 - REINFORCING STEEL

---

1. All reinforcing steel shall be deformed except spirals and welded wire fabric, which may be plain bars. Reinforcement shall be the grades required by the Contract Documents and shall conform to one of the following specifications:
  - a. ASTM A615 - Deformed and Plain Billet-Steel Bars for Concrete Reinforcement.
  - b. ASTM A616 - Rail-Steel Deformed and Plain Bars for Concrete Reinforcement (including supplementary requirements S1).
  - c. ASTM A617 - Axle-Steel Deformed and Plain Bars for Concrete Reinforcement.
  - d. ASTM A706 - Low-Alloy Steel Deformed Bars for Concrete Reinforcement.
  - e. Wire or wire fabric with a specified yield strength  $f_y$  exceeding 60,000 psi shall have the stress  $f_y$  corresponding to a strain of 0.35 percent.
  - f. Reinforcing steel shall conform to the applicable requirements of General Specifications 03300 – Cast-in-Place Concrete, 03410 - Precast Structural Concrete, 03450 - Precast Architectural Concrete and the New York City Building Code.

### B. Coated Reinforcing Bars:

1. When specified in the Detailed Specifications, reinforcing bars shall be zinc-coated (galvanized) or epoxy-coated. The reinforcing bars to be coated shall conform to the requirements of this Section.
  - a. Zinc-Coated (Galvanized) Reinforcing Bars: Zinc-coated (galvanized) reinforcing bars shall conform to ASTM A767. Supplementary requirements S1 and S2 shall apply when fabrication after galvanization includes cutting and bending. Supplementary requirement S2 shall apply when fabrication after galvanization includes only bending. Repair of damaged zinc coating when required shall be made with a zinc-rich formulation conforming to ASTM A767. Repair shall be done in accordance with the material manufacturer's recommendations.
  - b. Epoxy-Coated Reinforcing Bars: Epoxy-coated reinforcing bars shall conform to ASTM A775. Coating damaged due to shipping, handling and placing need not be repaired in cases where the damaged area is 0.1 square inches or smaller. Repair damaged areas larger than 0.1 square inches with patching material conforming to ASTM A775 and in accordance with the material manufacturer's recommendations. The maximum amount of damage including repaired and unrepaired areas shall not exceed 2 percent of the

## GENERAL SPECIFICATION 03210 - REINFORCING STEEL

---

surface area of each bar. Fading of the coating color will not be cause for rejection of epoxy-coated reinforcement.

### C. Bar Mats:

1. Bar mats shall be of the clipped type conforming to ASTM A184 and shall be fabricated from reinforcing bars that conform to the requirements of this Section.
  - a. When specified in the Detailed Specifications, bar mats shall be fabricated from zinc-coated (galvanized) reinforcing bars. Metal clips shall be zinc-coated (galvanized). Non-metallic clips may be used. Coating damage at the clipped intersections shall be repaired in accordance with the requirements of this Section.
  - b. When specified in the Detailed Specifications, bar mats shall be fabricated from epoxy-coated reinforcing bars. Metal clips shall be epoxy-coated. Non-metallic clips may be used. Coating damage at the clipped intersections shall be repaired in accordance with the requirements of this Section.

### D. Wire:

1. Wire shall be smooth or deformed wire as indicated in the Contract Documents.
  - a. Smooth wire shall conform to ASTM A82.
  - b. Deformed wire shall conform to ASTM A496, size D4 and larger.

### E. Welded Wire Fabric:

1. Welded wire fabric shall be fabricated from smooth or deformed wire and shall conform to the wire size and wire spacing required or indicated on the Contract Documents. Welded wire fabric shall conform to one of the following specifications:
  - a. Plain wire fabric ASTM 1064, except welded intersections shall be spaced not farther apart than 12 inches in the direction of the principal reinforcement.
  - b. Deformed wire fabric ASTM A497, except welded intersections shall be spaced not farther apart than 16 inches in the direction of the principal reinforcement.

### F. Spirals:

1. As indicated in the Contract Documents, spirals shall be fabricated from reinforcing bars or wire.

## GENERAL SPECIFICATION 03210 - REINFORCING STEEL

---

### 2.02 WIRE BAR SUPPORTS

- A. Unless permitted otherwise by the Detailed Specifications, wire bar supports shall be in accordance with Class 1, maximum protection or Class 2, moderate protection in Chapter 3 of CRSI DA4.

### 2.03 COATED WIRE REINFORCEMENT SUPPORTS

- A. For Epoxy-Coated Reinforcement:
  - 1. Use wire reinforcement supports coated with dielectric material including epoxy or other polymer for a minimum distance of 2 inches from the point of contact with epoxy-coated reinforcement.
- B. For Zinc-Coated Reinforcement:
  - 1. Use galvanized wire reinforcements supports or wire reinforcement supports coated with dielectric material with zinc-coated reinforcement.

### 2.04 PRECAST CONCRETE REINFORCEMENT SUPPORTS

- A. Concrete supports used for supporting reinforcement shall be not less than 4 inches square having a compressive strength equal to or greater than the specified compressive strength of the concrete being placed.

### 2.05 WELDING

- A. When required or permitted, all welding of reinforcing bars shall conform to ANSI/AWS D1.4. Unless otherwise permitted by the Engineer, welding of crossing bars (tack welding) for assembly of reinforcement is prohibited.
- B. Welding of wire to wire, and of wire or welded wire fabric to reinforcing bars or structural steels, shall conform to applicable provisions of ANSI/AWS D1.4 and any supplementary requirements specified by the Supervising Engineer for Concrete Construction for the particular application.
- C. After completion of welding on zinc-coated (galvanized) or epoxy-coated reinforcing bars, coating damage shall be repaired in accordance with the requirements of this Section. All welds and all steel splice members when used to splice bars shall be coated with the same material used for repair of coating damage.

### 2.06 DOWEL ADHESIVE SYSTEM

- A. Where shown on the Contract Drawings, reinforcing bars anchored into hardened concrete with a dowel adhesive system shall use a two-component adhesive mix which shall be injected with a static mixing nozzle following manufacturer's instructions.
- B. The embedment depth of the bar shall be per manufacturer's recommendations, so as to provide a minimum allowable bond strength that is equal to 125 percent of the yield strength of the bar, unless noted otherwise on the Contract Drawings.
- C. The adhesive system shall be:

**GENERAL SPECIFICATION 03210 - REINFORCING STEEL**

---

- a. HIT HY-150 Injection Adhesive Anchor System as manufactured by Hilti, Inc., Plano, TX.
- b. Epcon System as manufactured by ITW Ramset/Redhead, Glendale Heights, IL.
- 2. Sikadur Injection Gel as manufactured by Sika Corp., Lyndhurst, NY.
  - a. Sikadur Injection Gel as manufactured by Sika Corp., Lyndhurst, NY.
  - b. Or approved equal.
- D. The Engineer's approval is required for use of this system in locations other than those shown on the Contract Drawings.

2.07 TEMPERATURE REINFORCING

- A. Unless otherwise shown on the Contract Drawings or in the absence of the concrete temperature reinforcing being shown:
  - 1. The minimum cross sectional area of horizontal and vertical concrete temperature reinforcing in walls shall be 0.0033 times the gross concrete area.
  - 2. The minimum cross sectional area of temperature reinforcing perpendicular to the principal reinforcing in slabs shall be 0.0020 times the gross concrete area.
- B. Temperature reinforcing shall not be spaced further apart than five times the slab or wall thickness, nor more than 18 inches.

PART 3 EXECUTION

3.01 FABRICATION

- A. All reinforcement shall be bent cold unless otherwise permitted by the Engineer.
- B. Fabricating and Placing Tolerances:
- C. Reinforcing bars shall be fabricated in accordance with the standard fabricating tolerances in Figures 4 and 5 of ACI 315. Tolerances shall not permit a reduction in cover.
- D. Placing Tolerances for Reinforcement:

Item	Tolerances, Inches
1. Clear distance: <ul style="list-style-type: none"> <li>a. To formed soffit</li> <li>b. To other formed surfaces</li> </ul>	-1/4 ±1/4
2. Minimum spacing between bars:	-1/4

**GENERAL SPECIFICATION 03210 - REINFORCING STEEL**

---

Item	Tolerances, Inches
3. Clear distance from unformed surface to top reinforcement: a. Members 8 inches deep or less b. Members more than 8 inches deep but less than 24 inches deep c. Members 24 inches deep or greater	$\pm 1/4$ -1/4, +1/2  1/4, +1
4. Uniform spacing of bars, but the required number of bars shall not be reduced:	$\pm 2$
5. Uniform spacing of stirrups and ties, but the number of stirrups and ties shall not be reduced:	$\pm 1$
6. Longitudinal locations of bends <sup>o</sup> and ends of reinforcement: a. General b. Discontinuous ends of members	$\pm 2$ $\pm 1/2$
7. Length of bar laps:	1-1/2
8. Embedded length: a. For bar sizes No. 3 through 11 b. For bar sizes No. 14 and 18	-1 -2

- E. When it is necessary to move bars to avoid interference with other reinforcement, conduits or embedded items exceeding the specified placing tolerances, the resulting arrangement of bars shall be subject to approval of the Engineer.

3.02 PLACING

- A. Minimum concrete cover for reinforcement, except for extremely corrosive atmosphere, other severe exposures or fire protection shall be as follows unless indicated otherwise on the Contract Documents.
- B. Minimum Concrete Cover for Reinforcement:

Item	Minimum Cover, Inches
1. Slabs and Joists: a. Top and bottom bars for dry conditions: 1) No. 11 bars and smaller 2) No. 14 and No. 18 bars b. Bars in formed concrete surfaces exposed to water or weather, and over or in contact with sewage and for bottoms bearing on work mat, or slabs supporting earth cover:	3/4 1-1/2



**GENERAL SPECIFICATION 03210 - REINFORCING STEEL**

<b>Item</b>	<b>Minimum Cover, Inches</b>
1) No. 5 bars and smaller 2) No. 6 through No. 18 bars	1-1/2 2
2. Beams and Columns: a. For dry conditions: 1) Stirrups, spirals and ties 2) Principal reinforcement b. Exposed to earth, water, sewage or weather: 1) Stirrups and ties 2) Principal reinforcement	1-1/2 2 2 2-1/2
3. Walls: a. For dry conditions: 1) No. 11 bars and smaller 2) No. 14 and No. 18 bars b. Formed concrete surfaces exposed to earth, water, sewage, weather or in contact with ground	3/4 1-1/2 2
4. Footings and Base Slabs: a. At formed sides and ends and bottoms bearing on concrete work mat b. At unformed surfaces and bottoms in contact with earth c. Top of footings d. Over top of piles	2 3 Same as slabs 2

- C. For bundled bars, minimum concrete cover shall be equal to the equivalent diameter of the bundles but need not be greater than 2 inches; except for concrete deposited against and permanently in contact with ground, minimum cover shall be 3 inches. The equivalent diameter of the bundle shall be based on a single bar of a diameter derived from the equivalent total area.
- D. Unless otherwise indicated on the Contract Documents, reinforcement supported from the ground or mud mat shall rest on precast concrete blocks not less than 4 inches square and having a compressive strength equal to or greater than the specific compressive strength of the concrete being placed. Other means of support may be used if accepted by the Engineer.
- E. Reinforcement supported from formwork shall rest on bar supports made of concrete, metal, plastic or other acceptable materials. Where the concrete surface will be exposed to the weather in the finished structure, the portions of all bar supports within 1/2 inch of the concrete surface shall be non-corrosive or protected against corrosion.
- F. Zinc-coated (galvanized) reinforcing bars supported from formwork shall rest on galvanized wire bar supports coated with dielectric material or on bar supports

## GENERAL SPECIFICATION 03210 - REINFORCING STEEL

made of dielectric material or other acceptable materials. All other reinforcement and embedded steel items in contact with galvanized reinforcing bars or within a minimum clear distance of 2 inches from galvanized reinforcing bars unless otherwise required or permitted shall be galvanized.

- G. Epoxy-coated reinforcing bars supported from formwork shall rest on coated wire bar supports or on bar supports made of dielectric material or other acceptable materials. Wire bar supports shall be coated with dielectric material for a minimum distance of 2 inches from the point of contact with the epoxy-coated reinforcing bars. Reinforcing bars used as support bars shall be epoxy coated. In walls having epoxy-coated reinforcing bars, spreader bars, where specified, shall be epoxy coated. Proprietary combination bar clips and spreaders used in wall with epoxy-coated reinforcing bars shall be made of corrosion-resistant material or coated with dielectric material.
- H. Zinc-coated (galvanized) reinforcing bars shall be fastened with zinc-coated tie wire or non-metallic-coated tie wire or other acceptable materials.
- I. Epoxy-coated reinforcing bars shall be fastened with nylon-epoxy or plastic-coated tie wire; or other acceptable materials.
- J. Welded wire fabric for slabs on grade shall extend to within 2 inches of the concrete edge. Welded wire fabric may extend through the contraction joints. Welded wire fabric shall be adequately supported during placing of concrete to assure proper positioning in the slab.
- K. Bending or straightening of bars partially embedded in concrete shall not be permitted except when specifically approved by the Engineer. Bending and preheating shall be in accordance with the requirements of this Section.

### 3.03 BENDING OF BARS

- A. Minimum Inside Bend Diameters:
  - 1. The minimum inside bend diameters shall conform to the following requirements unless otherwise permitted by the Engineer.

Bar Size	Minimum Diameter
No. 3 through 8	6 bar diameters
No. 9, 10, 11	8 bar diameters
No. 14 and 18	10 bar diameters

- B. The beginning of the bend shall not be closer to the concrete surface than the minimum diameter of bend. Preheating, if required, shall be in accordance with the requirements of the Article 3.04. The following requirements shall be adhered to for individual bar sizes:

## GENERAL SPECIFICATION 03210 - REINFORCING STEEL

---

Bar Size	Bend Requirements
No. 3 through No. 5	Bars may be cold bent the first time. Cold bend bars only when temperature is above 32 degrees Fahrenheit. Preheating is required for subsequent straightening or bending.
No. 6 and larger	Preheating is required.

- C. When zinc-coated (galvanized) or epoxy-coated reinforcing bars are field bent, coating damage shall be repaired in accordance with the requirements of the Articles 2.02B.1 or 2.01B.2, respectively.
- D. **PREHEATING OF BARS**
- E. Preheating prior to bending or straightening, when required, shall be in accordance with the following requirements:
  - 1. The preheat shall be applied to a length of bar equal to at least 5 bar diameters each way from the center of the bend except that preheat shall not extend below the surface of the concrete. The temperature of the bar at the concrete interface shall not exceed 500 degrees Fahrenheit.
  - 2. The preheat temperature shall be 1100 to 1200 degrees Fahrenheit.
  - 3. The preheat temperature shall be maintained until bending or straightening is complete.
  - 4. The preheat temperature shall be measured by temperature measurement crayons, contact pyrometer or other acceptable method.
  - 5. Heated bars shall not be artificially cooled until the material temperature is less than 600 degrees Fahrenheit.
- F. Preheating may be applied by any method which does not harm the bar material or cause damage to the concrete.

### 3.04 SPLICING

- A. Reinforcing bar splices shall only be used at locations shown on the Contract Drawings. When it is necessary to splice reinforcing at points other than where shown, the character of the splice shall be approved by the Engineer.
- B. The length of lap for reinforcing bars, unless otherwise shown on the Contract Drawings shall be in accordance with ACI 318 for a class B splice.
- C. Laps of welded wire fabric shall be in accordance with ACI 318. Adjoining sheets shall be securely tied together with No. 14 tie wire, one tie for each 2 running feet. Wires shall be staggered and tied in such a manner that they cannot slip.

## GENERAL SPECIFICATION 03210 - REINFORCING STEEL

---

- D. Mechanical and welded splices shall be used only where shown on the Contract Drawings or when approved by the Engineer.
- E. Couplers which are located at a joint face shall be a type which can be set either flush or recessed from the face as shown on the Contract Drawings. The couplers shall be sealed during concrete placement to completely eliminate concrete or cement paste from entering. After the concrete is placed, couplers intended for future connections shall be plugged and sealed to prevent any contact with water or other corrosive materials. Threaded couplers shall be plugged with plastic plugs which have an O-ring seal.

### 3.05 DOWEL ADHESIVE SYSTEM INSTALLATION

- A. The installation of the dowels shall be done in strict conformance with the manufacturer's recommendations. The dowels shall be supported in the correct position until the adhesive sets and gains enough strength to prevent any dislocation.
- B. At least 25 percent of the dowels to be installed shall be proof tested to 1.33 times the allowable load specified by the manufacturer of the adhesive-injection system.
- C. If the dowels are required to have a hook at the end to be embedded in the new work, an approved mechanical coupler shall be provided at a convenient distance from the face of existing concrete to facilitate the testing.

### 3.06 MISCELLANEOUS INSTALLATION REQUIREMENTS

- A. Exposed Reinforcement:
  - 1. Reinforcement left exposed for the bonding of future construction shall be effectively protected from corrosion by encasement in cement mortar or by other temporary covering as approved by the Engineer.
- B. Field Cutting of Reinforcement:
  - 1. Reinforcement shall not be cut in the field except when specifically permitted by the Engineer in writing.
- C. Reinforcement Through Expansion Joint:
  - 1. Reinforcement or other embedded metal items bonded to the concrete shall not be continuous through any joint intended as an expansion joint. Dowels bonded on only one side of a joint and waterstops may extend through the joint.

### 3.07 INSPECTION

- A. No concrete shall be deposited until the Supervising Engineer for Concrete Construction or his approved representative has inspected the placing of the reinforcing steel and has given permission to place the concrete. Concrete placed in violation of this provision may be rejected with subsequent removal by the Contractor.

## **GENERAL SPECIFICATION 03210 - REINFORCING STEEL**

---

- B. The Contractor shall advise the Engineer of his intentions to place concrete and shall allow him adequate time to inspect all reinforcing steel before concrete is placed.
- C. The Contractor shall advise the Engineer of his intentions to place grout in masonry walls and shall allow him adequate time to inspect all reinforcing steel before grout is placed.

END OF SECTION

**GENERAL SPECIFICATION 03210 - REINFORCING STEEL**

---

NO TEXT ON THIS PAGE

**SECTION 03290  
Joints in Concrete**

**PART 1 GENERAL**

**1.01 SECTION INCLUDES**

- A. The Work specified in this Section consists of providing all labor, materials, and incidentals necessary to furnish and install joints, joint materials, waterstops and embedded items as indicated on the Contract Drawings, specified herein and as needed for a complete installation.
- B. Joints shall comply with the requirements of Section 03100 - Concrete Formwork.
- C. Types of joints in concrete shall be as follows:
  - 1. Construction Joints - Joints between adjacent concrete placements continuously connected with reinforcement.
  - 2. Control Joints - Joints formed in concrete to provide a weakened plane in the concrete section to control formation of shrinkage cracks.
  - 3. Expansion Joints - Joints in concrete which allow thermal expansion and contraction of concrete. Reinforcement terminates within concrete on each side of joint.
- D. The following index of this Section is included for convenience:

<u>Article</u>	<u>Title</u>	<u>Page</u>
		03290-
PART 1	GENERAL.....	1
1.01	Section Includes.....	1
1.02	Payment.....	2
1.03	Related Sections.....	2
1.04	References.....	2
1.05	Submittals.....	3
1.06	Quality Assurance.....	4
1.07	Product Delivery, Storage, And Handling.....	4
1.08	Field Measurements.....	5
1.09	Site Conditions.....	5
PART 2	PRODUCTS.....	6
2.01	Concrete Bonding Agent.....	6
2.02	Preformed Expansion Joint Filler.....	6
2.03	Joint Sealants.....	7
2.04	Backer Rod.....	7
2.05	Pvc Waterstops.....	8
2.06	Hydrophilic Rubber Waterstop.....	8

## GENERAL SPECIFICATION 03290 - JOINTS IN CONCRETE

---

2.07	Hydrophilic Sealant .....	9
2.08	Hydrophilic Injection Resin.....	9
2.09	Injection Hose Waterstop.....	9
PART 3	EXECUTION.....	10
3.01	Preparation .....	10
3.02	Construction Joints .....	10
3.03	Control Joints .....	11
3.04	Expansion Joints .....	12
3.05	Installation Of Joints And Joint Filler.....	12
3.06	Pvc Waterstops.....	13
3.07	Hydrophilic Waterstop.....	14
3.08	Injection Hose Waterstop.....	14
3.09	Protection .....	15
1.02	PAYMENT	
A.	Unless otherwise provided in the Detailed Specifications, no separate payment will be made for performing any Work of this Section and the Contractor shall include all costs thereof in its lump sum price bid for the Contract.	
1.03	RELATED SECTIONS	
A.	General Specification 03100 - Concrete Formwork.	
B.	General Specification 03300 - Cast-in-Place Concrete.	
1.04	REFERENCES	
A.	ASTM C 990 - Joints for Concrete Pipe, Manholes, and Precast Box Sections Using Preformed Flexible Joint Sealants.	
B.	ASTM C 1016 - Test Method for Determination of Water Absorption of Sealant Backing (Joint Filler) Material.	
C.	ASTM D 545 - Test Methods for Preformed Expansion Joint Fillers for Concrete Construction (Nonextruding and Resilient Types).	
D.	ASTM D 994 - Preformed Expansion Joint Fillers for Concrete (Bituminous Type).	
E.	ASTM D 1190 - Concrete Joint Sealer, Hot-Applied Elastic Type.	
F.	ASTM D 1191 - Test Methods for Concrete Joint Sealers.	
G.	ASTM D 1751 - Preformed Expansion Joint Filler for Concrete Paving and Structural Construction (Non-extruding and Resilient Bituminous Types).	



## GENERAL SPECIFICATION 03290 - JOINTS IN CONCRETE

---

- H. ASTM D 1752 - Preformed Sponge Rubber and Cork Expansion Joint Fillers for Concrete Paving and Structural Construction.
  - I. ASTM D 2835 - Lubricant for Installation of Preformed Compression Seals in Concrete Pavements.
  - J. ASTM D 5329 - Test Methods for Sealants and Fillers, Hot-Applied, For Joints and Cracks in Asphaltic and Portland Cement Concrete Pavements.
  - K. ASTM D 5973 - Elastomeric Strip Seals with Steel Locking Edge Rails Used in Expansion Joint Sealing.
  - L. ASTM D 5898 - Guide for Standard Details for Adhered Sheet Waterproofing.
  - M. ASTM E 1612 - Preformed Architectural Compression Seals for Buildings and Parking Structures.
  - N. ASTM E 1783 - Preformed Architectural Strip Seals for Buildings and Parking Structures.
  - O. ASTM F 1123 - Non-Metallic Expansion Joints.
  - P. ACI 318 - Building Code Requirements for Structural Concrete.
  - Q. New York City Building Code.
  - R. NYC Department of Transportation, Bureau of Highway Operations.
  - S. NY State Department of Public Works Specifications.
  - T. U.S. Army Corps of Engineers Waterstops Specifications.
- 1.05 SUBMITTALS
- A. Contractor shall submit Shop drawings and material specifications for the approval of the Engineer. Submittals shall include, but not be limited to:
    1. Information as shown on the Contract Drawings and at the site, where necessary.
    2. Sizes, sections, reinforcement and dimension of units, the jointing, dowels, anchors, etc., and all other necessary details.
    3. Installation of joints, including various connections, anchorage details, special jointing, the Contractor's proposed construction and control joints, and other accessories as required to complete the work.
    4. Prior to installation, the Contractor shall submit layout drawings for approval, showing the extent of the waterstop installations that are proposed to ensure that all construction and expansion joints, in water-

containing structures, will be watertight. The drawings shall include elevations, sections, etc., and all details to show that a continuous watertight installation is provided.

5. Equipment pad layout drawings.
- B. Manufacturer's specifications and installation instructions for each type of required joint and accessory shall be submitted. These include expansion joint fillers, expansion joint sealers, waterstops, shapes of waterstops, chemical retarders, adhesives, sleeves, inserts, anchors, embedded items, and similar items.
- C. The Contractor shall submit to the Engineer one sample of each type of waterstop. Each sample shall include a splice.
- D. Method to be used to roughen construction joints and achieve bond including product identification as applicable.
- E. Applicator's Qualifications.
- F. Proof of satisfactory field service of sealants.

#### 1.06 QUALITY ASSURANCE

- A. Reviews of Shop Drawings shall be obtained before custom fabrication is started and before delivery of materials to the project site.
- B. Work of this Section shall be coordinated with the work of other trades so that construction is not delayed.
- C. Joint installation procedures and health and safety of the work force shall be the responsibility of the Contractor. The requirements of authorities having jurisdiction shall be complied with.
- D. The final responsibility for constructing a watertight condition at expansion joints and construction joints remains with the Contractor as part of the work under this Contract. Errors of detailing and fabrication and for the correct fit of the work shall be the responsibility of the Contractor.
- E. Defective Work, as determined by the Engineer, shall be remedied by cutting and rebuilding the concrete walls and slabs, replacing the waterstop assemblies or other methods as approved by the Engineer.

#### 1.07 PRODUCT DELIVERY, STORAGE, AND HANDLING

- A. Materials shall be delivered to the site in an undamaged condition and at such intervals as will avoid delay in the Work.
- B. Materials shall be stored and protected in a clean, properly drained location and shall be kept off the ground under a weather-tight covering permitting good air circulation. Materials shall be stored on dry wood sleepers, pallets, platforms or other appropriate supports which have slope for positive drainage. Materials

shall be protected from distortion, excessive stresses, corrosion and other damage. Materials shall not be stored on the structure in a manner that might cause distortion or damage to the supporting structure. The maximum uniform distributed storage load shall not exceed 20 pounds per square foot.

- C. Material shall be handled safely in a manner that will prevent distortion or other damage. Care shall be exercised at all times to avoid damage through careless handling during unloading, storing and installing.

#### 1.08 FIELD MEASUREMENTS

- A. Prior to commencement of the Work, existing dimensions, elevations, locations and conditions applicable to the work shall be field verified. Variances and discrepancies from the Contract Drawings and potential interferences shall be reported promptly to the Engineer.
- B. Sufficient field measurements shall be taken prior to preparation of Shop Drawings and fabrication of construction materials, where possible, to ensure proper fitting of the work. However, job progress shall not be delayed. Allow for adjustments and fittings wherever the taking of field measurements before fabrication may not be possible or might delay the work.
- C. Actual field-verified conditions may require modifications to the fabrication and/or erection details indicated on the Contract Drawings. The Work shall be performed to meet actual field conditions encountered.

#### 1.09 SITE CONDITIONS

- A. Protection:
  - 1. Materials shall be protected before, during and after installation to ensure acceptable finished Work. In-place materials and other operations of Work in connection with the joint installations shall be protected.
  - 2. In the event of damage to the Work, necessary repairs or replacements shall be performed until satisfactory work is met at no expense to the City.
  - 3. The Contractor shall install joint material per the construction schedule submitted to and approved by the Engineer in a sequence and manner that will not damage the Work.

### PART 2 PRODUCTS

#### 2.01 CONCRETE BONDING AGENT

- A. The concrete bonding agent shall be:
  - 1. Corr-Bond, as manufactured by Euclid Chemical, East Brunswick, NJ.

2. Armatec 110, as manufactured by Sika Chemical Company, Lyndhurst, NJ
3. Or approved equal.

B. Surface preparation, application and curing shall be performed in strict accordance with the manufacturer's directions.

## 2.02 PREFORMED EXPANSION JOINT FILLER

A. Preformed expansion joint filler shall be nonextruding, and shall be of the following types:

1. Type I Sponge Rubber, conforming to ASTM D 1752, Type I.
2. Type II Cork, Conforming to ASTM Designation D 1752, Type II.
3. Type III Self-expanding cork, conforming to ASTM Designation D 1752, Type III.
4. Type IV Bituminous Fiber, conforming to ASTM Designation D 1751.

B. Expansion joint fillers shall be:

Type I

1. Type FF-7 cross-linked, closed cell polyethylene, as manufactured by Progress Unlimited Inc., Lynbrook, NY.
2. Type W, cross-linked, closed cell polyethylene, as manufactured by Hydrozo/Jeene, Inc, Lincoln, NE.
3. Or approved equal.

C. Unless otherwise specified, Type II and Type III shall conform to the requirements of the Standard Specifications of the NYC Department of Transportation, Bureau of Operations.

D. Asphaltic blown joint filler for sealing joints over Type IV preformed joint filler shall comply with the requirements of Section 2.16 of the Standard Specifications of the NYC Department of Transportation, Bureau of Highway Operations.

## 2.03 JOINT SEALANTS

A. Type A: Multi-component, non-sag, low-modulus polyurethane rubber sealant meeting ASTM C 920, Type M, Grade NS, Class 25, use NT, M, A, and O Capable of withstanding 50% in extension or compression shall be:

1. Sikaflex-2C NS/SL as manufactured by Sika Corporation, Lyndhurst, NY.
2. Sonolastic SL-1, as manufactured by Sonneborn/Master Business Solution, Parsippany, NJ.,

## GENERAL SPECIFICATION 03290 - JOINTS IN CONCRETE

---

3. Permapol RC-270 Reservoir Sealant, as manufactured by Products Research and Chemical Company, (now is Courtaulds, PLC,) London W1A2BB, England.
  4. Or approved equal.
- B. Type B: Single component polyurethane sealant meeting ASTM C 920, Type S, Grade NS, Class 25, Use NT, M, A, and O, capable of withstanding 25% in extension or compression shall be:
1. Magnum NS-100, as manufactured by Tamms Industries, Kirkland, IL.
  2. Sikaflex 1A, Sika Corporation, Lyndhurst, NY.
  3. Or approved equal.
- C. Type C: Multi-component chemical resistant polysulfide sealant conforming to ASTM C 920, Type M, Grade NS, Class 25 shall be:
1. Sonolastic Two-part, as manufactured by Sonneborn/Master Business Solution, Parsippany, NJ.
  2. Hornflex-L, as manufactured by Tamms Industries, Kirkland, IL.
  3. Cormax PSC, as manufactured by DuPont, (Multiple locations in USA).
  4. Or approved equal.
- 2.04 BACKER ROD
- A. Backer rod shall be an extruded closed-cell polyethylene foam rod. The material shall be compatible with the sealant material used and shall have a tensile strength of not less than 40 psi and a compression deflection of approximately 25 percent at 8 psi. The rod shall be 1/8-inch larger in diameter than the joint width at joints less than 3/4-inch wide and 1/4-inch larger in diameter at joints 3/4-inch end wider.
- 2.05 PVC WATERSTOPS
- A. PVC waterstops shall be manufactured from virgin polyvinylchloride and shall meet or exceed all requirements set forth in the U.S. Army Corps of Engineers Specification CRD C 572.
- B. All PVC waterstops shall be of polyvinylchloride extruded from an elastomeric plastic compound of which the basis resin shall be polyvinylchloride. The compound shall contain any additional resins, plasticizers, stabilizers or other materials needed to ensure qualities which will meet the requirements herein specified.
- C. The required minimum physical characteristics for this material are:
1. Tensile strength 1,750 psi

## GENERAL SPECIFICATION 03290 - JOINTS IN CONCRETE

---

2. Ultimate elongation not less than 280%.
- D. No reclaimed PVC materials shall be used for manufacture of the waterstops. The Contractor shall furnish certification that the proposed waterstops meet the above requirements.
- E. PVC waterstops for construction joints shall be flat ribbed type, 6 inches wide unless otherwise shown on the Contract Drawings, with a minimum thickness at any point of 3/8 inches.
- F. PVC waterstops for expansion joints shall be ribbed with a center bulb, 9 inches wide with a minimum thickness at any point of 3/8 inches. The center bulb shall have an O.D. not less than 1-3/8 inches.
- G. All PVC waterstops shall have an integral fastening system consisting of hog rings and grommets.
- H. PVC waterstops shall be:
  1. Model 679 for construction joints and Model 738 for expansion joints, as manufactured by Greenstreak/Sika Corp USA, Lyndhurst, NJ.
  2. Or approved equal.

### 2.06 HYDROPHILIC RUBBER WATERSTOP

- A. Hydrophilic rubber waterstop materials shall be bentonite-free and shall expand by a minimum of 80 percent of dry volume in the presence of water to form a watertight joint seal without damaging the concrete in which it is cast. For location, see the Contract Drawings.
- B. The material shall be composed of resins and polymers which absorb water and cause an increase in volume in a completely reversible and repeatable process. The waterstop material shall be dimensionally stable after repeated wet-dry cycles with no deterioration of swelling potential.
- C. Hydrophilic rubber waterstop shall be solid rectangular shape with minimum cross sectional dimensions of 3/8-inch by 3/4-inch.
- D. Hydrophilic Rubber Waterstops shall be:
  1. Duroseal Gasket, Type 2010, as manufactured by BBZ USA, Inc, St. Louis, MO
  2. Adeka Ultraseal MC-2010M, as manufactured by Asahi Denka Kogyo KK, Japan
  3. Or approved equal.

### 2.07 HYDROPHILIC SEALANT

- A. The Hydrophilic Sealants shall adhere firmly to concrete, metal and PVC in dry or damp conditions. When cured, it shall be elastic indefinitely.

- B. Hydrophilic Sealants shall be:
  - 1. Duroseal Paste, by BBZ USA, Inc, St. Louis, MO.
  - 2. Adeka Ultraseal P-201, by Asahi Denka Kogyo K.K, Japan.
  - 3. Sika Swell S, by Sika Corporation, Lyndhurst, NJ.
  - 4. Or approved equal.

2.08 HYDROPHILIC INJECTION RESIN

- A. Hydrophilic injection resin shall be acrylate-ester based. Its viscosity shall be less than 50 cps. It shall be water soluble in its uncured state, solvent free, and non-water reactive. In the cured state, it shall form a solid hydrophilic flexible material which is resistant to permanent water pressure and shall not attack bitumen, joint sealants or concrete.
- B. Hydrophilic Injection Resin shall be:
  - 1. Duroseal Inject 1K/2K, by BBZ, USA, Inc., St. Louis, MO.
  - 2. Sika Injection 29 by Sika Corporation, Lyndhurst, NJ.
  - 3. Or approved equal.

2.09 INJECTION HOSE WATERSTOP

- A. Injection hose shall consist of a PVC or neoprene central core of sufficient strength to resist the weight of a minimum of 25 feet of fresh concrete placed upon it. Injection openings shall be provided closely spaced along the length of the hose and in a minimum of three (3) locations equally spaced around the perimeter of the hose. The openings shall be sealed by strips of closed cell foam of a consistency to act as one-way valves preventing entrance of cement paste while allowing free flow of injection material, pumped through the hose, into the concrete joint surface.
- B. Injection hose system shall be appropriate for the injection of hydrophilic injection resin. The hose shall allow for vacuuming operations and repeated use. The construction of the hose shall permit free discharge of the specified injected grout into the concrete without backwash, for the entire length of the hose.
- C. Injection hose system shall be complete with hold-down clips, connection tubes, fittings and injection connections designed to be mounted flush with the concrete surface and sealed to allow for future injections. All components of the system shall be provided by the same manufacturer.
- D. Injection Hose Waterstops shall be:
  - 1. Fuko Injection System, as manufactured by BBZ USA Inc., St. Louis, MO.

2. Sika Swell Hose as manufactured by Sika Corporation, Lyndhurst, NJ.
3. Or approved equal.

**PART 3 EXECUTION**

**3.01 PREPARATION**

- A. The Contractor shall examine the areas and conditions under which the Work of this Section is to be performed. Conditions detrimental to the proper and timely completion of the Work shall be corrected. Work shall not be proceeded until unsatisfactory conditions have been corrected.
- B. All new placement of concrete shall be in accordance with Section 03300 – Cast-In-Place Concrete.
- C. Concrete shall not be allowed to enter the joint or the space for the sealant and destroy the proper functions of the joint.
- D. The surface of the concrete at all joints shall be thoroughly cleaned and all laitance removed by wire brushing, air or light sand blasting.
- E. The joint shall be thoroughly clean and free from dirt and debris before the primer and the sealant are applied. Where the finished joint will be visible, masking of the adjoining surfaces shall be carried out to avoid their discoloration. The sealant shall be neatly tooled into place and its finished surface shall present a clean and even appearance.
- F. All joints shall be sealed as shown on the Contract Drawings.

**3.02 CONSTRUCTION JOINTS**

- A. Construction joints shall be as shown on the Contract Drawings where structural integrity is affected, otherwise, Contractor shall submit description of the joint and its location to the Engineer for approval.
- B. Unless noted otherwise on the Contract Drawings, construction joints shall be located near the middle of the spans of slabs, beams, and girders unless a beam intersects a girder at this point. In this case, the joints in the girders shall be offset a distance equal to twice the width of the beam. Joints in walls and columns shall be at the underside of floors, slabs, beams, or girders and the top of footings or floor slabs unless noted otherwise on the Contract Drawings. Beams, girders, brackets, column capitals, haunches, and drop panels shall be placed at the same time as slabs. Joints shall be perpendicular to the main reinforcement.
- C. Maximum distance between horizontal joints in slabs and vertical joints in walls shall be 45'-0" unless otherwise indicated on the Contract Drawings.



- D. All corners shall be part of a continuous placement, and should a construction joint be required, the joint shall not be located closer than five feet from a corner.
  - E. Waterstop shall be provided at all joints in water retaining structures. Waterstop shall be provided at all joints below grade in walls or slabs which enclose an accessible area.
  - F. All reinforcing steel and welded wire fabric shall be continued across joints. Inclined dowels shall be provided as detailed or directed by the Engineer.
  - G. The surface of the concrete at all joints shall be thoroughly cleaned and all laitance removed. Following methods are acceptable:
    - 1. The use of an approved chemical retarder applied in accordance with the manufacturer's recommendations which delays but does not prevent the setting of the surface mortar. Retarded mortar shall be removed within 24 hours after placing to produce a clean exposed aggregate bonding surface.
    - 2. By roughening the surface of the concrete in an approved manner which will expose the aggregate uniformly and will not leave laitance, loosened particles of aggregate or damaged concrete at the surface.
  - H. All construction joints shall be bonded by one of the following methods:
    - 1. The use of an approved adhesive applied in accordance with the manufacturer's recommendations.
    - 2. Use of Portland cement grout of similar proportions to the mortar in the concrete in an acceptable manner.
- 3.03 CONTROL JOINTS
- A. Location of control joints shall be as shown on the Contract Drawings.
  - B. Control joints shall be formed with control joint inserts.
  - C. Sawcutting of control joints in lieu of forming shall not be allowed unless otherwise noted on the Contract Drawings. Where sawcutting is allowed, joints shall be sawed as soon as the concrete can support foot traffic without leaving any impression, normally the same day as concrete is placed and in no case longer than 24 hours after concrete is placed.
  - D. Unless noted otherwise on the Contract Drawings, depth of control joints shall be 1-1/2 inches in reinforced concrete and 1/3 of concrete thickness in unreinforced concrete.
- 3.04 EXPANSION JOINTS
- A. Size and location of expansion joints shall be as shown on the Contract Drawings.

- B. A center-bulb type waterstop shall be provided at all expansion joints in water-retaining structures. A center-bulb type waterstop shall be provided at all expansion joints below grade in walls or slabs which enclose an accessible area. Waterstop shall be as shown on the Contract Drawings and specified herein.
- C. Expansion joint filler for use in concrete pavements and structures shall be Types I, II, or III. Expansion joint filler-for use in sidewalk and curbing shall be Type IV.
- D. Reinforcement or other embedded items bonded to the concrete (except dowels in floors bonded on only one side of joint) shall not be permitted to extend continuously through any expansion joint.

3.05 INSTALLATION OF JOINTS AND JOINT FILLER

- A. Type B joint sealant shall be used in all expansion and control joints in concrete except Type A joint sealant shall be used in all concrete pavements and floors subject to heavy traffic and Type C joint sealant shall be used in high corrosive areas unless otherwise specified or shown on the Contract Drawings.
- B. Joint fillers and sealants shall be installed in accordance with manufacturer's recommended procedures and as shown on the Contract Drawings. Prior to sealant installation, the Contractor shall arrange to have a representative of the sealant manufacturer instruct the crew doing the work as to the proper methods of surface preparation, mixing and application of the sealant. The joint filler shall be furnished with a pressure sensitive adhesive or a separate adhesive as recommended by the manufacturer.
- C. Joint filler that will be exposed after removal of forms shall be cut and trimmed to ensure a neat appearance and shall completely fill the joint except for the space required for the sealant. The filler shall be held securely in place and no concrete shall be allowed to enter the joint or the space for the sealant and destroy the proper functions of the joint.
- D. A bond breaker of polyethylene film shall be used between filler and sealant. The joint shall be thoroughly clean and free from dirt and debris and shall receive a light sand blasting before the primer and the sealant are applied. Where the finished joint will be visible, masking of the adjoining surfaces shall be carried out to avoid their discoloration.
- E. The primer and sealant used shall be supplied by the same manufacturer. Sealant shall not be placed without the use of a primer.
- F. The sealant shall be neatly tooled into place and its finished surface shall present a clean and even appearance.
- G. The depth of the sealant shall not exceed the width of the joint.
- H. All sealants used in water retaining structures shall achieve final cure at least seven (7) days before the structure is filled with water.

**3.06 PVC WATERSTOPS**

- A. The design and location of PVC waterstops in construction joints and expansion joints shall be as indicated in the Detailed Specifications and on the Contract Drawings. Splices in PVC waterstops shall be made, and molded pieces used, as recommended by the manufacturer.
- B. Each piece of premolded PVC waterstop shall be of maximum practicable length in order that the number of end joints will be held to a minimum.
- C. Joints shall develop effective watertightness fully equal to that of the continuous PVC waterstop material and shall permanently develop not less than 80 percent of the mechanical strength of the parent section and shall permanently retain its flexibility.
- D. PVC waterstops shall be installed in the Work so that they are embedded to an equal depth in concrete on both sides of the joint in keyways as shown on the Contract Drawings and shall be kept free from oil, grease, mortar or other foreign matter. PVC waterstops shall be adequately secured against movement during the pouring of concrete. Contractor shall submit methods of PVC waterstop installation to the Engineer for approval prior to placing the concrete. Concrete adjacent to PVC waterstops shall be placed in 12 inch lifts and power vibrated to prevent honeycombing, voids and separation of aggregates at the surfaces of concrete separation joints.
  - 1. PVC waterstop fabrications for all changes of direction, intersections and transitions shall be made in the shop, leaving only straight butt joint splices for the field.
  - 2. Butt joint splices of PVC waterstop runs shall be made by heat sealing the adjacent surfaces in accordance with the manufacturer's recommendations using a thermostatically controlled electric source of heat. At least three satisfactory field splices shall be made as samples on site. The Engineer may require tests on these splices by an approved laboratory, at the Contractor's expense, to certify the tensile strength of the joint. The strength attained shall be at least 80% of the unspliced material before any is used in the work.

**3.07 HYDROPHILIC WATERSTOP**

- A. Hydrophilic rubber waterstop or sealant shall be installed in accordance with the manufacturer's instructions and recommendations, except as modified herein.
- B. The manufacturer shall provide technical assistance in the field.
- C. The waterstop or sealant shall be located as near as possible to the center of the joint and shall be continuous around the entire joint. The minimum distance from the edge of the waterstop to the face of the member shall be 3 inches.

- D. Where a hydrophilic rubber waterstop is used in combination with PVC waterstop, the hydrophilic rubber waterstop shall overlap the PVC waterstop for a minimum of 6 inches. The contact surface between the hydrophilic rubber waterstop, and the PVC waterstop shall be filled with hydrophilic sealant.
- E. The hydrophilic rubber waterstop shall be installed in a bed of hydrophilic sealant, before skinning and curing begins, so that any irregularities in the concrete surface are completely filled and the waterstop is bonded to the sealant. After the sealant has cured, concrete nails, with washers of a diameter equal to the waterstop width shall be placed to secure the waterstop to the concrete at a maximum spacing of 18 inches.
- F. Prior to installation of hydrophilic sealant, the concrete surface shall be wire brushed or sand blasted to remove any laitance or other materials that may interfere with the bonding. Surfaces of metal or PVC to receive sealant shall be cleaned of paint and any material that may interfere with bond. When sealant alone is shown on the Contract Documents, it shall be placed in a built-up bead which has a triangle cross section with each side of the triangle at least 3/4 inch in length, unless indicated otherwise. Concrete shall not be placed until the sealant has cured in accordance with the manufacturer's recommendations.

3.08 INJECTION HOSE WATERSTOP

- A. The injection hose shall be installed in maximum lengths of 40 feet and shall be located as shown on the Contract Drawings. The hose shall be clamped into position with anchor clips spaced approximately 6 to 10 inches apart.
- B. The concrete surface shall be cleaned of stones and debris prior to installation of injection hose. The injection hose shall be installed in direct contact with the face of concrete at the construction joint to prevent floating of the hose in the freshly placed concrete.
- C. Where injection hose is used in combination with PVC waterstop, the hose shall overlap the PVC waterstop for a minimum of 6 inches and shall be less than 2 inches away from the PVC.
- D. The injection procedure shall be performed in strict conformance with the manufacturer's recommendations. The injection shall be made by an authorized applicator as recommended by the injection system supplier.
- E. The injection system supplier or his approved representative shall provide the necessary supervision to satisfy the Engineer that the application conforms strictly to the manufacturer's recommendations.
- F. The injector hose and opposite hose vent for each hose length shall be terminated in the injection boxes mounted on the dry side of the wall. At the end of the injection operation, the hose shall be cleaned in accordance with the procedure recommended by the manufacturer. The injection ends and the vents

## GENERAL SPECIFICATION 03290 - JOINTS IN CONCRETE

---

shall be plugged and the box covered leaving the system ready for reinjection in the event that the joint is leaking.

### 3.09 PROTECTION

- A. Joints and accessories shall be protected from damaging from traffic during the entire construction period. Waterstops provided for adjoining future structures shall be protected from corrosion as shown on the Contract Drawings.

END OF SECTION

NO TEXT ON THIS PAGE

**SECTION 03300  
Cast-in-Place Concrete**

**PART 1 GENERAL**

**1.01 SECTION INCLUDES**

- A. The Work specified in this Section consists of providing all labor, materials, equipment, supervising, testing and incidentals necessary to furnish and install cast-in-place concrete as indicated on the Contract Drawings and as specified herein.
- B. Work includes producing concrete consisting of Portland cement, fine and coarse aggregate, water and approved admixtures; proportioned, mixed, transported, placed, finished and cured as specified. Work shall also include:
  - 1. Providing openings in concrete as required to accommodate Work under this and other Sections and Contracts.
  - 2. Building into the concrete all items such as sleeves, frames, anchor bolts and inserts required to accommodate Work under this and other Sections and Contract Drawings.
- C. This Section covers cast-in-place structural concrete for use in buildings and structures and miscellaneous cast-in-place concrete.
- D. An index of the Articles in this Section is presented hereinafter for the convenience of the Contractor.

<u>Article</u>	<u>Title</u>	<u>Page</u>
		03300-
		03300-
PART 1	GENERAL.....	1
1.01	Section Includes.....	1
1.02	Related Specifications.....	2
1.03	Payment.....	2
1.04	References.....	2
1.05	Definitions.....	6
1.06	Description.....	7
1.07	Quality Assurance.....	8
1.08	Submittals.....	12
1.09	Delivery, Storage And Handling.....	15
PART 2	PRODUCTS.....	16
2.01	General.....	16
2.02	Cementitious Materials.....	16
2.03	Aggregate.....	17
2.04	Concrete Admixtures.....	20

## GENERAL SPECIFICATION 03300 – CAST- IN-PLACE CONCRETE

---

2.05	Water.....	22
2.06	Proportioning And Mix Design .....	22
2.07	Bonding Agent.....	25
2.08	Finishing Aids.....	26
2.09	Curing And Protection Materials .....	26
2.10	Crack Injection Materials.....	28
2.11	Concrete Repair Materials .....	28
PART 3	EXECUTION.....	29
3.01	Inspection.....	29
3.02	Mixing And Transporting Concrete.....	29
3.03	Preparation For Concrete .....	36
3.04	Concrete Placement .....	36
3.05	Concrete Curing And Protection.....	43
3.06	Mass Concrete.....	46
3.07	Field Quality Control .....	49
3.08	Concrete Repairs.....	64
1.02	RELATED SECTIONS	
A.	General Specification 03100 - Concrete Formwork	
B.	General Specification 03210 - Reinforcing Steel	
C.	General Specification 03290 - Joints in Concrete	
D.	General Specification 03350 - Concrete Finishes	
E.	General Specification 03600 - Grout	
F.	General Specification 03931 - Concrete Rehabilitation	
1.03	PAYMENT	
A.	Unless otherwise provided in the General Specifications, no separate payment will be made for performing any Work required under this Section and the Contractor shall include all costs thereof in its lump sum price bid for the Contract.	
1.04	REFERENCES	
A.	American Association of State Highway and Transportation Officials (AASHTO):	
1.	AASHTO M 182.....Burlap Cloth Made From Jute or Kenaf	
2.	AASHTO TP 23.....Proposed Standard Method of Test for Water Content of Freshly Mixed Concrete Using Microwave Oven Drying	



## GENERAL SPECIFICATION 03300 – CAST-IN-PLACE CONCRETE

---

3. AASHTO T 318.....Proposed Standard Method of Test for Water Content of Freshly Mixed Concrete Using Microwave Oven Drying
- B. American Concrete Institute (ACI):
  1. ACI 116R.....Cement and Concrete Terminology
  2. ACI 117.....Standard Tolerances for Concrete Construction and Materials
  3. ACI 207.1R.....Mass Concrete
  4. ACI 211.1.....Standard Practice for Selecting Proportions for Normal, Heavyweight and Mass Concrete
  5. ACI 213.....Guide for Structural Lightweight-Aggregate Concrete
  6. ACI 214.....Recommended Practice for Evaluation of Strength Test Results of Concrete
  7. ACI 301.....Specification for Structural Concrete
  8. ACI 302R.....Guide for Concrete Floor & Slab Construction
  9. ACI 304R.....Guide for Measuring, Mixing, Transporting and Placing Concrete
  10. AC 305R.....Hot Weather Concreting
  11. ACI 306R.....Cold Weather Concreting
  12. ACI 308.1.....Specification for Curing Concrete
  13. ACI 309R.....Guide for Consolidation of Concrete
  14. ACI 311.....Recommended Practice for Concrete Inspection
  15. ACI 318.....Building Code Requirements for Structural Concrete
  16. ACI 347R.....Guide to Formwork for Concrete
  17. ACI 506.....Guide to Shotcrete
  18. ACI 506.2.....Specification for Shotcrete
  19. ACI SP-2.....ACI Manual of Concrete Inspection
  20. ACI SP-15.....Field Reference Manual Standard Specifications for Structural Concrete ACI 301 with selected ACI references.

## GENERAL SPECIFICATION 03300 – CAST-IN-PLACE CONCRETE

---

- C. American National Standards Institute/National Science Foundation (ANSI/NSF) Standard 61 - “Drinking Water System Components - Health Effect”
- D. American Society for Testing and Materials (ASTM)
  - 1. ASTM C 31.....Standard Practice for Making and Curing Concrete Test Specimens in the Field
  - 2. ASTM C 33.....Standard Specification for Concrete Aggregates
  - 3. ASTM C39.....Standard Test Method for Compressive Strength of Cylindrical Concrete Specimens
  - 4. ASTM C 42.....Standard Method for Obtaining and Testing Drilled Cores and Sawed Beams of Concrete
  - 5. ASTM C 88.....Standard Test Method for Soundness of Aggregates by Use of Sodium Sulfate or Magnesium Sulfate
  - 6. ASTM C 94.....Standard Specification for Ready-Mixed Concrete
  - 7. ASTM C 109.....Standard Test Method for Compressive Strength of Hydraulic Cement Mortars
  - 8. ASTM C 138.....Standard Test Method for Unit Weight, Yield, and Air Content (Gravimetric) of Concrete
  - 9. ASTM C 143.....Standard Test Method for Slump of Hydraulic Cement Concrete
  - 10. ASTM C 150.....Standard Specification for Portland Cement
  - 11. ASTM C 157.....Standard Test Method for Length Change of Hardened Hydraulic-Cement, Mortar, and Concrete
  - 12. ASTM C 171.....Standard Specification for Sheet Materials for Curing Concrete
  - 13. ASTM C 172.....Standard Practice for Sampling Freshly Mixed Concrete
  - 14. ASTM C 173.....Standard Test Method for Air Content of Freshly Mixed Concrete by the Volumetric Method

## GENERAL SPECIFICATION 03300 – CAST-IN-PLACE CONCRETE

---

15. ASTM C 227.....Standard Test Method for Potential Alkali Reactivity of Cement-Aggregate Combinations
16. ASTM C 231.....Standard Test Method for Air Content of Freshly Mixed Concrete by the Pressure Method
17. ASTM C 260.....Standard Specification for Air-Entraining Admixtures for Concrete
18. ASTM C 309.....Standard Specification for Liquid Membrane-Forming Compounds for Curing Concrete
19. ASTM C 311.....Test Method for Sampling & Testing Fly Ash or Natural Pozzolans for Use in Concrete
20. ASTM C 330.....Standard Specification for Lightweight Aggregates for Structural Concrete
21. ASTM C 387.....Standard Specification for Packaged, Dry Combined Materials for Mortar and Concrete
22. ASTM C 470.....Standard Specification for Molds for Forming Concrete Test Cylinders Vertically
23. ASTM C 494.....Standard Specification for Chemical Admixtures for Concrete
24. ASTM C 567.....Standard Test Method for Density Structural Lightweight Concrete
25. ASTM C 595.....Standard Specification for Blended Hydraulic Cements
26. ASTM C 618.....Standard Specification for Coal Fly Ash and Raw or Calcined Natural Pozzolan for Use in Concrete
27. ASTM C845.....Standard Specification for Expansive Hydraulic Cement
28. ASTM C 881.....Standard Specification for Epoxy-Resin-Base Bonding Systems for Concrete
29. ASTM C 882.....Standard Test Method for Bond Strength of Epoxy-Resin Systems Used With Concrete By Slant Shear

## GENERAL SPECIFICATION 03300 – CAST-IN-PLACE CONCRETE

---

30. ASTM C 979.....Standard Specification for Pigments for Integrally Colored Concrete
  31. ASTM C 989.....Standard Specification for Slag Cement for Use in Concrete and Mortars
  32. ASTM C 1064.....Standard Test Method for Temperature of Freshly Mixed Portland Cement Concrete
  33. ASTM C 1077.....Standard Practice for Agencies Testing Concrete and Concrete Aggregates for Use in Construction and Criteria for Testing Agency Evaluation
  34. ASTM C 1141.....Specification for Admixtures for Shotcrete
  35. ASTM C 1157.....Standard Performance Specification for Hydraulic Cement
  36. ASTM C 1240.....Standard Specification for Silica Fume for Use as a Mineral Admixture in Hydraulic-Cement Concrete, Mortar, and Grout
  37. ASTM C 1398.....Test Method for Laboratory Determination of time of Setting of Hydraulic-Cement Mortars Containing Additives for Shotcrete by the Use of Gillmore Needles
  38. ASTM C 1480.....Packaged, Pre-Blended, Dry, Combined Materials for Use in Wet or Dry Shotcrete Application
  39. ASTM E 329.....Standard Specification for Agencies Engaged in the Construction Inspection Testing of Special Inspection
- E. The Building Code of the City of New York (NYCBC or BC)
- F. Concrete Plant Manufacturer’s Bureau (CPMB) - “Concrete Plant Standards.”
- G. Concrete Reinforcing Steel Institute (CRSI):
1. CRSI – “Manual of Standard Practice”
  2. CRSI – “Placing Reinforcing Bars”

### 1.05 DEFINITIONS

- A. The following items are defined for general use in these specifications:
1. Inspection Requirements – Special Inspections requirements of the New York City Building Code as defined in BC 1704.4 shall apply to all applicable materials and construction.

## GENERAL SPECIFICATION 03300 – CAST- IN-PLACE CONCRETE

---

2. Lightweight Concrete - Concrete intentionally made to have low density by use of lightweight aggregate and usually required to have an air-dry unit weight less than 115 lbs. per cubic foot.
3. Normal Weight Concrete - Concrete for which density is not a controlling attribute, made with aggregates of types covered by ASTM C 33, and usually having unit weights in the range of 135 to 160 lbs. per cubic foot.
4. Supervising Engineer for Concrete Construction - Professional Engineer designated by the Commissioner, who will be responsible for and coordination of Special Inspections and Buildings Form TR1: . Technical Report Statement of Responsibility. The Supervising Engineer for Concrete Construction may or may not be the Resident Engineer. The Supervising Engineer for Concrete Construction shall undertake all responsibilities outlined in Article 28 and BC1704.4 Special Inspections of the New York Building Code.

B. Other technical words and terms used in this Section are defined in ACI 116R.

### 1.06 DESCRIPTION

A. Classes of Concrete:

1. Class 25 - use for lean concrete.
2. Class B-32 for NYCDOT specification sidewalks, headers and curb.
3. Class 40LW - use for structural lightweight concrete
4. Class 45 - use for all concrete unless indicated otherwise.
5. Class 45 concrete with a corrosion inhibitor and crystalline waterproofing in the mix design.
6. Class 45F - use as an alternate to Class 45 for:
  - a. Foundations
  - b. Walls greater than or equal to 18inches in thickness
7. Class 45M - use for mass concrete. Class 45M mix-design requirements shall be provided in the General Specifications. Where such requirements are not included in the General Specifications, Class 45F shall be used for mass concrete applications.
8. Class 45HES- use for High Early Strength concrete, minimum 4,500 psi @ 7days with corrosion inhibitor and crystalline waterproofing.
9. Class 50 - use for precast concrete with corrosion inhibitor and crystalline waterproofing in the mix design. This mix shall be used for all precast concrete, unless indicated on the Contract Documents.

B. Work in Connection with other disciplines:

1. All sleeves, inserts, anchors and embedded items required for adjoining work or for its support shall be placed prior to concreting. No concrete shall be deposited until the Resident Engineer or his authorized representative has inspected the placement of the embedded items and the reinforcing bars and has given his permission to place the concrete.
2. All Work related to the concrete or must be supported by it, shall be coordinated with the work of this Section, including but not limited to the introduction or furnishing of embedded items prior to concrete placement.
3. Electrical conduits, junction boxes or pipes shall be placed prior to concreting. The Contractor shall coordinate the placement of such items of work in order that they are installed in accordance with all requirements of the New York City Building Code. The Contractor shall protect such installations to the extent that they are not displaced or damaged during concrete placement.
4. Openings in slabs shall be provided for pipes, conduits and the like required for the work of others where indicated on the contract drawings or for which directions are given prior to placing concrete. When work of others is completed, the excess part of the respective openings shall be completely closed up to the pipe sleeve and/or inserts to match the adjoining work.
5. Sleeves for miscellaneous metalwork, castings, pipes and anchors furnished shall be set true and to proper alignment in the concrete as indicated on the Contract Drawings or required by the manufacturer's templates.
6. Voids in embedments shall be filled temporarily with readily removable material to prevent entry of concrete into the void.

1.07 QUALITY ASSURANCE

A. General:

1. Work performed under this Section shall comply with the applicable provisions and recommendations in the References Article of this Section.
2. The Contractor shall employ, at its own expense, a testing laboratory experienced in the design and testing of concrete materials and mixes. This laboratory shall be responsible for all concrete mix design and trial batch testing.
  - a. Unless otherwise approved, all mix designs shall be run in the presence of DEP designated personnel.

## GENERAL SPECIFICATION 03300 – CAST-IN-PLACE CONCRETE

---

3. Testing agencies that perform testing services on concrete shall meet the requirements of ASTM E 329 and be licensed by the New York City Department of Buildings.
  4. Testing laboratory shall have been inspected within the last 2 years by the Cement and Concrete Reference Laboratory (CCRL) of the National Institute of Standards and Technology for testing concrete aggregates and for the preparation and testing of concrete trial batches with or without admixtures. The laboratory shall provide documentation indicating how any deficiencies in the latest CCRL inspection report have been corrected.
  5. Testing and inspection shall be conducted in accordance with the requirements of ASTM C 1077 and other applicable standards.
  6. Prior to performing any Work, the qualifications of the proposed testing agency shall be submitted for review and acceptance by the Owner.
  7. Tests of concrete required by this Section shall be made by an ACI Concrete Field Testing Technician Grade 1 or equivalent. Equivalent certification programs shall include requirements for written and performance examinations as stipulated in ACI publication CP1.
  8. Prior to approval, all testing of proposed materials and mix designs including trial batch and shrinkage testing shall be at the Contractor's expense.
  9. Concrete materials and operations will be tested and inspected by the Supervising Engineer for Concrete Construction or his authorized representative as the work progresses. Failure to detect defective work or material shall not in any way prevent later rejection when a defect is discovered nor shall it obligate the Engineer for final acceptance.
  10. Materials and installed Work may require testing and retesting, as directed by Engineer, at any time during the progress of the Work. Contractor shall allow free access to material stockpiles and facilities at all times. Tests not specifically indicated to be done at Owner's expense, including the retesting of rejected materials and installed Work, shall be done at Contractor's expense.
- B. Laboratory Trial Batch:
1. Each concrete mix specified shall be verified by a laboratory trial batch, unless indicated otherwise. Each trial batch shall also be witnessed by a DEP representative.
  2. Each trial batch shall be reported on DEP's Mix Design Submittal (MDS) forms and shall include the following testing:
    - a. Aggregate gradation for fine and coarse aggregates.

## GENERAL SPECIFICATION 03300 – CAST- IN-PLACE CONCRETE

---

- b. Combined aggregate gradation including total percentage of each aggregate size retained on each sieve.
  - c. Fly ash testing to verify meeting specified properties, unless certification by an independent testing laboratory is provided by the fly ash supplier.
  - d. Slump.
  - e. Air content.
  - f. Compressive strength based on 3 cylinders tested at 7 days and 3 cylinders tested at 28 days (6 cylinders minimum.)
  - g. Shrinkage test, as specified herein, for Class 45 concrete except Class 45M.
3. Each trial batch shall provide the following information:
- a. Project identification name and number.
    - 1) Specified strength  $f'c$ .
    - 2) Name of the concrete producer supplying materials.
    - 3) Name of the Design Trial Lab.
  - b. Date of trial.
  - c. Complete identification of aggregate source of supply.
  - d. Tests of aggregates for compliance with specified requirements.
  - e. Scale weight of each aggregate.
  - f. Absorbed water in each aggregate.
  - g. Brand, type and composition of cement.
  - h. Brand, type and amount of each admixture.
  - i. Amounts of water used in trial mixes.
  - j. Proportions of each material per cubic yard.
  - k. Gross weight and yield per cubic yard of trial mixtures.
  - l. Measured slump.
  - m. Measured air content.
  - n. Shrinkage test results where required and as specified herein.
  - o. A minimum of three (3) trial runs with different water/cement ratios shall be performed for each mix design proposed.
  - p. Compressive strength developed at 7 days and 28 days, and if required, 56 days or longer. A minimum of three (3) test



cylinders shall be cast for each 7-day, 28-day and/or 56-day test for each trial run.

4. The requirement for a trial batch may be waived if the required test information has been provided in a previous laboratory trial batch run on the identical mix design within the previous twelve (12) months and the history of the concrete mix field results are acceptable to the Supervising Engineer for Construction. The same brand, type, source and supplier of all materials must have been used.
5. On the day of the trial test, the laboratory shall provide to the DEP witness a 1-2 lb. neat cement sample for delivery to the DEP Laboratory for chemical composition analysis, for fly ash and slag and cement.

C. Shrinkage Test:

1. Drying shrinkage tests, as specified herein, shall be performed with every trial batch test.
2. Drying shrinkage specimens shall be 4-inch by 4-inch by 11-inch prisms with an effective gage length of 10 inches, fabricated, cured, dried and measured in accordance with ASTM C 157 modified as follows: Specimens shall be removed from molds at an age of  $23 \pm 1$  hours after trial batching, shall be placed immediately in water at 70 degrees F  $\pm 3$  degrees F for at least 30 minutes, and shall be measured within 30 minutes thereafter to determine original length and then submerged in saturated lime water at 73 degrees F  $\pm 3$  degrees F. Measurement to determine expansion expressed as a percentage of original length shall be made at age 7 days. This length at age 7 days shall be the base length for drying shrinkage calculations (“0” days drying age). Specimens then shall be stored immediately in a humidity control room maintained at 73 degrees F  $\pm 3$  degrees F and 50 percent  $\pm 4$  percent relative humidity for the remainder of the test. Measurements to determine shrinkage expressed as percentage of base length shall be made and reported separately for 7, 14, 21, and 28 days of drying after initial 7 days of moist curing.
3. The drying shrinkage deformation of each specimen shall be computed as the difference between the base length (at “0” days drying age) and the length after drying at each test age. The average drying shrinkage deformation of the specimens shall be computed to the nearest 0.0001 inch at each test age. If the drying shrinkage of any specimen departs from the average of that test age by more than 0.0004-inch, the results obtained from that specimen shall be disregarded. Results of the shrinkage test shall be reported to the nearest 0.001 percent of shrinkage. Compression test specimens shall be taken in each case from the same concrete used for preparing drying shrinkage specimens. These tests

## GENERAL SPECIFICATION 03300 – CAST- IN-PLACE CONCRETE

---

shall be considered a part of the normal compression tests for the project. Allowable shrinkage limitations shall be as specified in Part 2, herein.

### 1.08 SUBMITTALS

#### A. General:

1. The Contractor shall submit to the Engineer, in accordance with Section 01330 – Submittal Procedure for all concrete and grout mix designs.
2. A new mix design shall be submitted to the Engineer for approval. Prior to changing the brand, type, size or source of cementitious materials, aggregates, water, ice or admixtures, new historical field strength test data, data from new trial mixtures or evidence which indicates that the change will not adversely affect the relevant properties of the concrete shall be submitted.
3. Materials, equipment and aggregates approved by the Materials Bureau of the New York State Department of Transportation (NYSDOT), in the most recent NYSDOT approved lists mentioned below, are acceptable for use without a detailed submission. Submittal is required stating the particular material, equipment or aggregate source to be used with approval identification number, and/or page number.
  - a. Materials and Equipment NYSDOT Approved Materials List
  - b. Approved List Sources of Fine and Coarse Aggregates

#### B. Certifications:

1. All materials used in the manufacture of concrete shall be accompanied by a certificate from the manufacturer or fabricator or supplier indicating test results of current production stockpiles or shipments.
2. Submit notarized certification of conformance to referenced standards when requested by Engineer.

#### C. Delivery Tickets:

1. The Contractor shall submit to the Engineer with a copy of the delivery ticket for each load of concrete delivered to the site. Delivery tickets shall contain all information specified in ASTM C94 Section 14.1.
2. Provide batch tickets for each batch of job-site mixed concrete as specified.

#### D. Submit samples of materials as specified and as otherwise may be requested by the Engineer, including names, sources, and descriptions.

#### E. Shop Drawings:

## GENERAL SPECIFICATION 03300 – CAST- IN-PLACE CONCRETE

---

1. Manufacturer's specifications with application and installation instructions for proprietary materials and items, including admixtures and bonding agents.
2. All information pertinent to a concrete plant to be erected at the site as required by the CPMB Publication "Concrete Plant Standards of the Concrete Plant Manufacturers Bureau."
3. Detailed description of conveying equipment.
4. Detailed description of concrete placement methods.
5. Proposed procedures for bonding new concrete work to existing including manufacturer's information on proposed bonding agents.
6. Proposed normal procedures for protection and curing of concrete including manufacturer's literature for proposed curing compounds.
7. Proposed special procedures for protection of concrete under wet weather placement conditions.
8. Proposed special procedures for protection and curing of concrete under hot and cold weather conditions.
9. Proposed method for underwater placement.
10. Proposed method of measuring concrete surface temperature changes.
11. Detailed procedures and materials for repair of defective concrete.
12. Detailed procedures for removing stains, rust, efflorescence, and surface deposits.
13. Materials and procedures to be used to plug tie holes, other than for Portland cement mortar.
14. Proposed methods to measure concrete compressive strength by means other than field cured cylinders for termination of curing, such as maturity, penetration resistance, pulse velocity, rebound hammer, or pullout strength.
15. The following information, if ready-mixed concrete is used.
  - a. Identification of Ready-Mixed Concrete Supplier including the plant location and all pertinent information required by the CPMB Publication "Concrete Plant Standards of the Plant Manufacturers Bureau."
  - b. Locations of sources of materials for cement, fine and coarse aggregates, and water, and the brands and types of admixtures to be used.
  - c. Physical capacity of mixing plant.

- d. Trucking facilities available.
  - e. Estimated average amount which can be produced and delivered to the site during a normal 8-hour day, excluding the output to other customers.
16. Requests and Notifications:
- a. Request to use the volumetric batching method.
  - b. Request for acceptance of preplacement activities: This request is to ensure that the pre-placement activities are complete and have been properly inspected. The Contractor shall sign-off on a Concrete Placement Card indicating that the Work is complete and is ready for placement. A sample of the required Concrete Placement Card is shown as Attachment 03300 B at the end of this document. The Supervising Engineer for Concrete Construction will sign-off on the items to be inspected but this does not relieve the Contractor from coordinating the concrete placement properly and meeting all requirements of the Contract. The Contractor shall submit the completed Concrete Placement Card to the Supervising Engineer for Concrete Construction in accordance with Article 3.03 Preparation for Concrete of this General Specification, and with sufficient time to obtain receipt of authorization from DEP to place concrete in conformance with the latest DEP concrete placing guidelines.
  - c. Advance notification of forthcoming placement including arrangements to coordinate tests and inspection.
  - d. Requests to exceed the ASTM C 94 required time of discharge.
- F. Test and Inspection Reports:
- 1. Information on types, classes, procedures, names and plant locations for cementitious materials; types, pit or quarry locations, producers' names, gradations and properties required by ASTM C 33 for aggregates; types, brand names, producers' names for admixtures; and source of supply for water and ice.
  - 2. Except for admixtures and water, test results not more than 90 days old confirming the conformance of all concrete materials with applicable specifications.
  - 3. Testing agencies shall submit the results of all tests and inspections performed during the course of the work to the Supervising Engineer for Concrete Construction. Reports from the Testing Agency shall be on forms acceptable to the Supervising Engineer for Concrete Inspection.

## GENERAL SPECIFICATION 03300 – CAST- IN-PLACE CONCRETE

---

4. Submit copies of laboratory test reports for concrete cylinders, materials and mix design tests. Engineer's review will be for information only. Production of concrete to comply with the specified requirements is the responsibility of the Contractor.
5. A complete record of the date and details of each concrete placement including the exact location thereof and the date of removal of forms. This record shall be coordinated with and in addition to that maintained by the Supervising Engineer for concrete inspection.
6. Mixture Proportions:
  - a. Mixture proportions conforming to the requirements of the New York City Administrative Building Code and this Section for water/cement ratio, cement content, slump, maximum size of coarse aggregate, air content, admixtures, and chloride concentration, as well as compressive strength.
  - b. Method and test data used to establish proportions.

### 1.09 DELIVERY, STORAGE AND HANDLING

- A. Cement shall be stored in weather tight buildings, bins or silos which will provide protection from dampness and contamination and will minimize warehouse set.
- B. Aggregate stockpiles shall be arranged and used in a manner to avoid excessive segregation or contamination with other materials or with any other sizes of like aggregates. To insure that this condition is met, any test for determining conformance to requirements for cleanliness and grading shall be performed on samples secured from the aggregates at the point of batching. Frozen or partially frozen particles shall not be used.
- C. Stockpiles of natural sand shall be allowed to drain freely to minimize variations in moisture content throughout the stockpile.
- D. Admixtures shall be stored in such a manner as to avoid contamination, evaporation or damage. For those used in the form of suspensions or non-stable solutions, suitable agitating equipment shall be provided to assure uniform distribution of the ingredients. Liquid admixtures shall be protected from freezing and other temperature changes which would adversely affect their characteristics. All admixture containers shall be clearly marked with paint as to their content and dosage.
- E. Lightweight Aggregates:
  1. Cover or presoak coarse and fine lightweight aggregates when transporting them.
  2. Presoak dry lightweight aggregates unless presoaking is not recommended by the aggregate supplier or is not acceptable to the

## GENERAL SPECIFICATION 03300 – CAST- IN-PLACE CONCRETE

---

Engineer. Leave presoaked aggregates in the stockpile after soaking for at least 12 hours before using.

3. Do not allow machinery to run over lightweight aggregates.

### PART 2 PRODUCTS

#### 2.01 GENERAL

- A. All materials used in concrete or the curing and repair of concrete, which can contact potable water, shall be certified as meeting the requirements of ANSI/NSF 61 for contact with potable water when in the finished concrete.
- B. Materials listed in this Section apply to all concrete unless specified otherwise in the General Specifications or for specific applications in other General or Detailed Specifications.

#### 2.02 CEMENTITIOUS MATERIALS

##### A. Cement:

1. Portland cement, ASTM C 150, Type II; or blended hydraulic cement, ASTM C595 Type IP (MS) or as otherwise specified in the Detailed Specifications. Cement type used shall be appropriate for site exposures.
  - a. NYC BC 1904.4
2. Portland cement shall be produced by an acceptable, recognized manufacturer. The cement shall be produced by one plant only per mix design. Alternate cement sources may be used provided that a mix design has been accepted and a trial batch verifying performance has been made.
3. Cement which has deteriorated because of improper storage or handling shall be rejected.

##### B. Fly Ash and Natural Pozzolans:

1. Fly ash mineral admixture, when used, shall meet the requirements of ASTM C 618 Class F, except as follows:
  - a. The loss on ignition shall be a maximum of 4%.
  - b. The maximum percent of sulfur trioxide (SO<sub>3</sub>) shall be 4.0.
2. Natural pozzolan mineral admixture, when used, shall meet the requirements of ASTM C 618 Class N.
3. Fly ash and natural pozzolans used in concrete that contacts potable water shall be certified as meeting the requirements of ANSI/NSF 61.

##### C. Ground Granulated Blast Furnace Slag:

## GENERAL SPECIFICATION 03300 – CAST- IN-PLACE CONCRETE

---

1. Ground granulated blast furnace slag (GGBF) mineral admixture, when used, shall meet the requirements of ASTM C 989, Grade 100 or better.
2. GGBF slag will be permitted as a substitute for fly ash or natural pozzolans, at no additional cost to the City, in the event that Class F Fly Ash or Class N natural pozzolans are not available. The slag substitution shall be in the same proportions and percentages of the total cementitious material as indicated for Fly Ash. A higher percentage of GGBF slag of the total cementitious material in concrete shall be permitted as approved by the Engineer to suit the project needs.
3. Laboratory trial batches will be tested to determine compliance with strength requirements, times of setting, slump, slump loss, and shrinkage characteristics.
4. GGBF slag used in concrete that contacts potable water shall be certified as meeting the requirements of ANSI/NSF 61.

### D. Silica Fume:

1. Silica fume mineral admixture shall be the dry compacted or slurry form and shall meet the requirements of ASTM C 1240. Silica Fume shall be considered to be a cementitious material. Application rate shall be 7 percent by weight of cement, unless indicated otherwise.
2. Product and Manufacturer: Provide one of the following:
  - a. Rheomac SF100, as manufactured by BASF Construction Chemicals, LLC.
  - b. Force 10,000 D, as manufactured by W.R. Grace & Company.
  - c. Sikacrete 950 DP, as manufactured by Sika Corporation.
  - d. Eucon MSA, as manufactured by the Euclid Chemical Company.
  - e. Or equal.

### 2.03 AGGREGATE

- A. Coarse and fine aggregates shall meet the requirements of ASTM C 33 with the requirements of Table 3, Class 4S. Soundness shall be tested using magnesium sulfate. Abrasion resistance shall be tested using the Los Angeles Abrasion Test. For testing requirements, concrete shall be assumed to be subject to abrasion.
- B. Do not use aggregates containing soluble salts or other substances such as iron sulfides, pyrite, marcasite, ochre, or other materials that can cause stains on exposed concrete surfaces. Marine dredged aggregates shall not be used.

## GENERAL SPECIFICATION 03300 – CAST- IN-PLACE CONCRETE

---

- C. The loading, storing, unloading, and batching of aggregates shall be done in such a manner as to prevent segregation, intermingling, or the inclusion of foreign materials. All aggregates shall remain in free drainage storage until a stable moisture content is attained prior to placement in the batching plant bins. Each size of coarse aggregate and the fine aggregate shall be kept in separate hoppers or bins. All aggregates shall be delivered to the batching plant bins by a belt conveyor or other approved means; and the operation thereof shall be controlled so as to prevent the mixing of the sizes and kinds of aggregates with each other. Any mixture of fine and coarse aggregates or of the two sizes of coarse aggregate in the batching plant bins or prior thereto shall be cause for rejection of such materials, and the affected bin or bins shall be emptied and inspected prior to refilling with the correctly graded aggregate.
- D. Fine Aggregates:
1. Fine aggregate shall be composed of clean, sharp, hard, strong, durable, insoluble, uncoated, natural sand free from loam, clay lumps or other deleterious substances.
  2. Dune sand, bank run sand and manufactured sand are not acceptable.
  3. Sand having FM less than 2.40 or greater than 3.00 shall not be allowed.
  4. Fine aggregate shall meet the requirements of ASTM C 33 except that loss when tested for soundness using magnesium sulfate shall not exceed 12 percent.
- E. Coarse Aggregates:
1. Coarse aggregate shall be crushed stone processed from natural rock or stone and shall consist of clean, hard, strong, durable, insoluble, unweathered, and uncoated pieces of uniform quality throughout; and shall be free from such alkali, decomposed minerals, organic material, clay, mica, schist, or other foreign matter that will render it unsuitable.
  2. Use of slag and pit or bank run gravel is not permitted.
  3. Coarse aggregate gradations shall be as specified in Table 1 - Concrete Mix Requirements and shall meet the requirements of ASTM C 33. All aggregate gradations listed for each concrete class shall be used.
  4. Coarse aggregate shall meet the requirements of ASTM C 33, Table 3, Class 4S, with the following additional requirements.
    - a. Clay lumps shall not exceed 1.0 percent by weight of coarse aggregate.
    - b. Shale and other soft particles shall not exceed 3.0 percent by weight of coarse aggregate.



- c. Thin, elongated, or laminated particles shall not exceed 3.0 percent by weight of coarse aggregate.
    - d. Loss when tested for soundness using magnesium sulfate shall not exceed 12 percent.
  - 5. Coarse aggregate for lightweight concrete shall conform to ASTM C 330 and shall meet the gradation requirements for ¾” to No. 4.
  - 6. Nominal maximum size of coarse aggregate shall be not larger than:
    - a. 1/5 the narrowest dimension between sides of forms, nor
    - b. 1/3 the depth of slabs, nor
    - c. ¾ the maximum clear spacing between individual reinforcing bars or wires, bundles of bars, individual tendons, bundled tendons or ducts.
  - 7. The requirements of Article 2.03, Paragraph E.6, shall not apply if, in the judgment of the licensed design professional, workability and methods of construction are such that concrete can be placed without honeycombs or voids.
- F. Combined Aggregate:
  - 1. Aggregate gradations shall be determined during trial batch testing and shall be based upon the combined gradation and particle distribution in the mixture of coarse and fine aggregates.
  - 2. Fine aggregate and coarse aggregate sizes specified shall be combined to produce a workable and cohesive concrete mix that is appropriate for its specific application. Coarse aggregate contents shall be based on Table 6.3.3 of ACI 211.1. Adjust the content required for pumping applications as specified in ACI 211.1.
  - 3. The total quantity of fine aggregate shall be not more than 45 percent nor less than 32.5 percent by weight of the total aggregate for normal weight concrete. Using a total quantity of fine aggregate which does not meet this specified range shall only be acceptable when approved by the Engineer. The total quantity of fine aggregate shall be not more than 45 percent nor less than 32.5 percent by weight of the total aggregate for normal weight concrete. Using a total quantity of fine aggregate which does not meet this specified range shall only be acceptable when approved by the Engineer
  - 4. Gradations of combined aggregate shall be plotted and submitted on:
    - a. A combined grading chart (percent passing versus sieve size).
    - b. An aggregate Particle Distribution Chart (percent retained versus sieve size).

## GENERAL SPECIFICATION 03300 – CAST- IN-PLACE CONCRETE

---

- G. Fine and coarse lightweight aggregates for lightweight concrete shall conform to ASTM C 330. From 20 to 35 percent shall pass the No. 50 sieve and 10 to 20 percent shall pass the No. 100 sieve in the sand fraction gradation. Normal weight aggregate for lightweight concrete shall conform to ASTM C 33.

### 2.04 CONCRETE ADMIXTURES

- A. Provide admixtures produced by established reputable manufacturers, and use in compliance with the manufacturer's printed instructions. All admixtures shall be compatible and by a single manufacturer capable of providing qualified field service representation. Do not use admixtures which have not been incorporated and tested in the accepted mixes, unless otherwise authorized in writing by ENGINEER.
- B. Air entraining admixtures shall conform to the NYS DOT Materials Bureau approved list and ASTM C 260.
- C. Normal range or midrange water reducing admixture shall be in conformance with ASTM C 494 Type A, and comply with the NYS DOT Materials Bureau approved list.
- D. High-Range Water Reducing Admixture:
  - 1. High range water reducer shall conform to ASTM C 494, Type F or G and comply with the NYS DOT Materials Bureau approved list.
  - 2. The high range water reducing admixture shall be accurately measured and added at the batch plant facility. The Contractor may redose the concrete no more than 2 times with the high range water reducer at the site, provided that a calibrated dispenser system and containers of high range water reducer sealed and labeled by the manufacturer are used.
- E. Set Controlling Admixture:
  - 1. Set controlling admixture shall be either with or without water-reducing properties.
  - 2. Where the air temperature at the time of placement is expected to be consistently over 90 degrees Fahrenheit, a water-reducing set controlled admixture conforming to ASTM C 494, Type D and the NYS DOT Materials Bureau approved list.
  - 3. Where the air temperature at the time of placement is expected to be consistently under 40 degrees Fahrenheit, except for mass concrete placement, a non-corrosive, non-chloride accelerator conforming to ASTM C 494, Type C and the NYS DOT Materials Bureau approved list shall be used.
- F. Shrinkage Reducing Admixture:

## GENERAL SPECIFICATION 03300 – CAST- IN-PLACE CONCRETE

---

1. A shrinkage reducing admixture is permitted to be used in the mix design where necessary to meet specified shrinkage limitations provided that specified strength requirements are met and there is no reduction in sulfate resistance and no increase in permeability.
  2. Shrinkage reducing admixtures shall be one of the following:
    - a. Eclipse, manufactured by Grace Construction Products.
    - b. Tetraguard AS20, manufactured by BASF Construction Chemicals, LLC.
    - c. Or an Approved Equal.
- G. Corrosion Inhibiting Admixture:
1. Corrosion inhibiting admixture shall be a calcium nitrite solution containing a minimum of 30 percent calcium nitrite.
  2. The quantity of mix water shall be adjusted to account for the water portion of the calcium nitrite solution.
  3. As the calcium nitrite solution accelerates setting time, retarding admixtures shall be provided as needed, unless the admixture has been formulated to not accelerate setting.
  4. Corrosion inhibiting admixture shall be one of the following:
    - a. DCI or DCI-S, manufactured by Grace Construction Products.
    - b. Rheocrete CNI, manufactured by BASF Construction Chemicals, LLC.
    - c. Eucon CIA, manufactured by Euclid Chemical Company.
    - d. Or an Approved Equal.
- H. Calcium chloride, admixtures containing thiocyanate, or admixtures containing more than 0.05 percent chloride ions shall not be used.
- I. Crystalline Waterproofing, added crystalline based permeability reducing admixture. Crystalline waterproofing admixture use appropriate manufacturer's product for specific contract work.
1. Crystalline waterproofing shall be one of the following:
    - a. Eucon Vandex AM-10 manufactured by Euclid Chemical
    - b. Sika WT-215P manufactured by Sika Corporation
    - c. XYPEX Admix C-500 or C-1000, manufactured by XYPEX Chemical Company
    - d. Krystol Internal Membrane (KIM) manufactured by Kryton
    - e. Or an Approved Equal.

## GENERAL SPECIFICATION 03300 – CAST- IN-PLACE CONCRETE

### 2.05 WATER

- A. Water for concrete, mortar, and grout shall be clean and free from objectionable mineral salts and from injurious amounts of oils, acids, alkalis, organic materials, or other substances that may be deleterious to concrete or steel. Water shall meet the requirements of ASTM C 94.

### 2.06 PROPORTIONING AND MIX DESIGN

- A. Prepare concrete design mixes subject to the limitations listed in Table 1 and specified herein so as to create a homogeneous mix and a concrete which meets the specified strength requirements and, of equal importance, provides a concrete which is water tight and durable against deterioration and abrasion. The mix design shall produce a concrete of a consistency which can be placed so as to meet the required finished appearance. The minimum cement necessary to produce the required strength shall be used. This Section applies to concrete mixes using ½ inch and larger nominal maximum aggregate. For mixes using smaller aggregate sizes, see General Specification 03600 - Grout. The mix design shall be submitted using the Mix Design Submittal Form at the end of this Section.
- B. Air Content:
1. All concrete shall be air entrained unless indicated otherwise.
  2. Air content for normal weight concrete shall be as follows:

Nominal Maximum Aggregate Size (in.)	Total Air Content, percent by Volume (+/- 1.5%)
1/2	7
3/4	6
1	6
1-1/2	5.5

- C. Lightweight concrete shall contain 6 percent  $\pm$ 2 percent total air when the nominal maximum size of coarse aggregate is greater than 3/8 in., or 7 percent  $\pm$  2 percent when the nominal maximum size is 3/8 in. or less as determined in accordance with ASTM C173. Slump:
1. Slump for all concrete shall be 3 +/- 1 inches, unless indicated otherwise.
  2. Where high range water reducing admixture is used, the specified water-cementitious material ratio shall be reduced by 0.02 and concrete shall be proportioned for no higher than 3-inch slump. The slump after

addition of the high range water reducing admixture shall not exceed 8 inches when measured at the point of placement.

3. A tolerance of up to 2 inch above the maximum indicated slump shall be allowed for one batch in any five consecutive batches tested provided that it can be demonstrated that the specified water-cementitious material ratio is not exceeded.
  4. The slump of lightweight concrete for floors shall not exceed 4 in. at the point of placement.
  5. For troweled floors, the slump of structural lightweight concrete with 100 percent normal weight sand discharged by pump shall not exceed 4 in. at the point of placement.
- D. Shrinkage Limitation:
1. The maximum concrete shrinkage for specimens cast in the laboratory from the trial batch, as measured at 21-day drying age or at 28-day drying age shall be 0.039 percent or 0.045 percent, respectively. The Contractor shall only use a mix design for construction that has first met the trial batch shrinkage requirements. Shrinkage limitations shall not apply to Class 25 and 40LW concrete, unless indicated otherwise.
  2. If the trial batch results fail to meet the shrinkage limitation, the mix shall be redesigned to reduce shrinkage. Alternately, the Contractor may use a higher shrinkage mix when acceptable to the Engineer provided that the amount of shrinkage reinforcement in the structures is increased as determined by the Engineer to resist the higher levels of shrinkage stresses. The additional reinforcing shall be provided at the Contractor's expense.
- E. The percentage of mortar in the concrete mix shall not exceed 60 percent for Class 50, 45 and 45F concrete. Exceeding this specified mortar percentage shall only be acceptable when approved by the Engineer.
- F. The unit weight limitations for lightweight concrete shall be as shown on the Contract Drawings.
- G. Proportioning: Concrete proportions shall be determined in accordance with the provisions of Sections 1905.2.1 through 1905.2.3 of the NYCBC.
1. Proportions of materials for concrete shall be established to provide
    - a. The proportioning of ingredients shall produce a mixture that will provide workability and consistency to permit concrete to be worked readily into the corners and angles of the forms and around reinforcement by the methods of placing and consolidation employed on the work, but without permitting the

## GENERAL SPECIFICATION 03300 – CAST-IN-PLACE CONCRETE

---

- materials to segregate or excessive bleeding. Yield of all mixes as designed shall not exceed 27.2 cu.ft./cu.yd.
- b. Resistance to special exposures are required by NYCBC Section 1904.
  - c. Conformance with the strength test requirements of Sections 1905.6
2. Concrete is to meet the durability requirements of Section 1904 of NYCBC.
  3. The determination of the concrete mix proportion to attain the required strength shall be in accordance with the procedure, as designated by the General Specifications in the schedule set forth therein and as specified herein. All mixes shall be approved by the registered design professional or record, prior to construction.
  4. Where different materials are to be used for different portions of proposed work, each combination shall be evaluated.
  5. Concrete proportions shall be established in accordance with NYCBC Section 1905.3 or Section 1905.4, and shall comply with the applicable requirements of Section 1904.
    - a. NYCBC Section 1905.3 - Proportioning on the basis of field experience/or trial mixtures. Concrete proportioning determined on the basis of field experience or trial mixtures shall be done in accordance with ACI 318, Section 5.3. If the required  $f'_c$  is obtained for trial batch mixed prior to the date specified, the trial mix design may be approved. All mixes shall be approved by the registered design professional of record, prior to construction.
    - b. NYCBC Section 1905.4 - Proportioning without field experience. Concrete proportioning determined without field experience or trial mixtures shall be done in accordance with ACI 318, Section 5.4. This method of proportioning shall not be permitted for load-carrying structural concrete or concrete mix proportions that are required to conform to NYCBC Section 1904.
  6. Proportioning on the basis of field experience and/or trial mixtures using a mix design employing the same ingredients proposed for use, and used successfully on a previous project, or projects, may be used provided the following are submitted by a licensed concrete testing laboratory and approved by the Design Engineer of record in conformance with BC 1905.3 and ACI 318 Section 5.3..
    - a. The name and location of the plant from which the concrete will be batched.

- b. The concrete mix design including detailed data and analysis of the ingredients proposed for use as specified herein.
  - c. Reports for at least 30 (thirty) consecutive tests of 7 day and 28 day concrete strength tests of the proposed mix made during the previous twelve months of concrete batched and delivered from the same plant that is to furnish this job. These data shall include an evaluation in accordance with ACI 214 to determine the average strengths, moving averages and the coefficients of variation. In addition, the results of a minimum of 3 shrinkage tests for this mix made during the previous twelve months and using the same materials to be used on this project.
  - d. Reports of compliance tests of fine and coarse aggregates made during the above tests.
- 7. Average strength reduction. As data becomes available during construction, it is permissible to reduce the amount by which the average compressive strength ( $f'_c$ ) is required to exceed the specified value of  $f'_c$  in accordance with ACI 318, Section 5.5
  - 8. Evaluation and acceptance of concrete. The criteria for evaluation and acceptance of concrete shall be as specified in NYCBC Sections 1905.6.3.3 through 1905.6.5.5.
  - 9. Qualified technicians. Concrete frequency and testing shall be tested in accordance with the requirements of NYCBC Section 1905.6.2 thru 1905.6.5.5. An agency shall perform tests on fresh concrete at the job site, prepare specimens required for curing under field conditions, prepare specimens required for testing in the laboratory and record the temperature of the fresh concrete when preparing specimens for strength tests. All field sampling and testing, including the testing of aggregates, concrete mixes, and strength testing of specimens, shall be subject to special inspection by an approved agency. All testing laboratories shall be approved testing agencies and shall employ qualified special inspectors to perform all required laboratory tests. Test results shall be promptly distributed by the testing laboratory to the registered design professional of record, concrete producer, owner and contractor.

2.07 BONDING AGENT

- A. Provide a two component epoxy-resin bonding agent conforming to ASTM C 881.
- B. Product and Manufacturer: Provide one of the following:
  - 1. Sikadur 32, Hi-Mod LPL, as manufactured by Sika Corporation.
  - 2. Eucopoly LPL MV, as manufactured by the Euclid Chemical Company.

3. Or an Approved Equal.
- C. Provide three component epoxy modified cementitious bonding agent where two component bonding agent does not provide sufficient open time.
- D. Product and Manufacturer: Provide one of the following:
1. Sika Armatec 110 EpoCem, as manufactured by Sika Corporation.
  2. Or as Approved Equal.

2.08 FINISHING AIDS

- A. Evaporation Retardant:
1. Evaporation retardant shall be a material which seals the surface of plastic concrete to prevent moisture loss. The material shall be able to be worked into the concrete surface by subsequent finishing operations with no adverse effect on finishing effort and no discoloration of the finished concrete.
  2. Evaporation retardant shall be one of the following:
    - a. Confilm, as manufactured by BASF Construction Chemicals, LLC.
    - b. Eucobar, as manufactured by Euclid Chemical Company.
    - c. SikaFilm, as manufactured by Sika Corporation.
    - d. Or an Approved Equal.

2.09 CURING AND PROTECTION MATERIALS

- A. Absorptive covers shall consist of burlap cloth made from jute or kenaf, weighing approximately 10 ounces per square yard and complying with AASHTO M 182, Class 3.
- B. Curing mats shall be heavy carpets or cotton mats, quilted at 4 inches on center. Curing mats shall weigh a minimum of 12 ounces per square yard when dry.
- C. Moisture retaining covers shall conform to ASTM C 171 and consist of one of the following materials.
1. Waterproof paper.
  2. Polyethylene film.
  3. White burlap-polyethylene sheet.
- D. Curing compounds shall conform to the requirements of ASTM C 309 Type 1-D (water retention requirements):
1. Provide one of the following:



## GENERAL SPECIFICATION 03300 – CAST- IN-PLACE CONCRETE

---

- a. Super Aqua Cure VOX, as manufactured by The Euclid Chemical Company.
  - b. Sealtight 1100, as manufactured by W.R. Meadows, Inc.
  - c. MasterKure, as manufactured by BASF Construction Chemicals, LLC.
  - d. Or an Approved Equal.
2. Provide fugitive dye when requested by Engineer.
- E. Insulation Blankets:
1. Closed cell flexible foam sheet material such as polystyrene or urethane. Foam sheet material which is capable of being bent 90 degrees without breaking or tearing shall be provided at corners. The foam insulation blankets shall be 1/2-inch thick.
  2. Quilted, flexible insulation blankets that retain their insulating value when wet and which retard the evaporation of water.
- F. Temperature Monitoring Equipment:
1. Thermocouples or thermistors shall be as manufactured by James Instruments Inc. or equal. They shall be suitable for embedment in concrete and capable of registering temperatures within the accuracy of 0.5 degrees Fahrenheit over a minimum temperature range of 20 to 200 degrees Fahrenheit.
  2. Temperature monitoring and recording equipment shall consist of rechargeable battery-powered recording thermometers with microprocessors such as the IQT-Meter or the IQM-Meter as manufactured by James Instruments Inc. or equal. The equipment shall be capable of taking and recording temperature readings at each temperature sensor at preset time intervals. The thermometer units shall be compatible with the temperature sensors used, shall have a non-volatile memory capacity of at least 120 readings per sensor, and shall be designed to be connected to a battery-powered compatible printer unit. Time periods shall be able to be set over a minimum range of 10 to 60 minutes. The thermometer unit shall be designed and constructed for construction conditions. Sufficient thermometer units shall be provided to take readings from all temperature sensors plus one additional backup unit for every ten units in service. One printer unit shall be provided for every 20 thermometer units with sufficient paper supply to record all readings taken.

2.10 CRACK INJECTION MATERIALS

A. Epoxy:

1. Epoxy for injection shall be a low viscosity, high modulus moisture insensitive type.
2. Epoxies for injection shall be:
  - a. Sikadur 35, Hi-Mod L.V. and Sikadur 31, Hi-Mod Gel, as manufactured by Sika Corporation.
  - b. Eucopoxy Injection Resin, as manufactured by The Euclid Chemical Company.
  - c. Or an Approved Equal.

B. Hydrophilic Resin:

1. Hydrophilic resin shall be an acrylic-ester based resin with a maximum viscosity of 50 cps. It shall cure into a flexible rubber-like material which has the potential for unrestrained increase in volume in excess of 100 percent in the presence of water.
2. Hydrophilic resins shall be:
  - a. Duroseal Inject, as manufactured by BBZ USA, Inc.
  - b. Or an Approved Equal.

2.11 CONCRETE REPAIR MATERIALS

A. Concrete repair mortar shall be a prepackaged polymer-modified cementitious repair mortar with the following minimum properties:

1. Compressive strength at one day: 2000 psi (ASTM C 109).
2. Compressive strength at 28 days: 6000 psi (ASTM C 109).
3. Bond strength at 28 days: 1800 psi (ASTM C 882 modified).

B. Concrete repair mortar shall be:

1. Five Star Structural Concrete, manufactured by Five Star Products, Inc. The formulation recommended by the manufacturer for the specific application conditions shall be used.
2. SikaTop 122 Plus, SikaTop 123 Plus, SikaTop 111 Plus, or Sikacem 133, manufactured by the Sika Corporation. The formulation, among those listed, recommended by the manufacturer for the specific application conditions shall be used.
3. Emaco S88-CI or S66-CI, manufactured by BASF Construction Chemicals, LLC. The formulation, among those listed, recommended by the manufacturer for the specific application conditions shall be used.

4. Verticoat or Verticoat Supreme, manufactured by the Euclid Chemical Company. The formulation, among those listed, recommended by the manufacturer for the specific application conditions shall be used.
  5. Or equal.
- C. Cement mortar shall consist of a mix of 1 part cement to 1 1/2 parts sand with sufficient water to form a trowelable consistency. Minimum compressive strength at 28 days shall be 4000 psi. Where required to match the color of adjacent concrete surfaces, white portland cement shall be blended with standard portland cement so that, when dry, the patching mortar shall match the color of the surrounding concrete.

### PART 3 EXECUTION

#### 3.01 INSPECTION

- A. The Contractor and its installer shall examine the substrate and the conditions under which Work is to be performed and notify Engineer in writing of unsatisfactory conditions. Do not proceed with the Work until unsatisfactory conditions have been corrected in a manner acceptable to Engineer.

#### 3.02 MIXING AND TRANSPORTING CONCRETE

A. General:

1. The Contractor shall provide the production of concrete which includes batching, mixing, delivering, and discharging of concrete according to the following requirements.

B. Ready-Mixed Concrete:

1. Ready-Mixed concrete shall be batched, mixed and transported in accordance with the appropriate sections of “Specifications for Ready-Mixed Concrete” (ASTM C 94 or ASTM C685). Follow the detailed recommendations given in Guide for Measuring, Mixing, Transporting, and Placing Concrete (ACI 304R), where applicable.
2. Each truck mixer or agitator shall have attached thereto in a prominent place a metal plate issued by the Truck Mixer’s Manufacturer’s Bureau by the manufacturer complying with Section 11.1.2 of ASTM C 94 for that truck mixer and the limitations thereon shall be strictly adhered to.
3. Ready-mixed concrete shall only be batched in plants which meet the following:
  - a. Concrete plants shall be certified by the National Ready Mixed Concrete Association (NRMCA) and shall comply with the rules of the department.

## GENERAL SPECIFICATION 03300 – CAST- IN-PLACE CONCRETE

---

- b. Upon written application by the producer, accompanied by a detailed report on how the facilities compare with the standards of the NRMCA, the above requirements may be waived, in writing by the Engineer.
    - c. If the detailed report mentioned above is issued by the testing agency which will perform the inspection of the batching and mixing of the concrete and indicates that satisfactory quality concrete can be produced by the plant in question, based on prior job performance records, then the above requirement will be waived, in writing, by the Supervising Engineer for Concrete Construction.
  4. Approval of plants as outlined above is subject to the continuous checking and acceptance by the Commissioner or his duly authorized representative.
  5. Only plants meeting the requirements for certification of the NRMCA for automatic batching and automatic recording will be permitted.
    - a. If at any time automatic proportioning or recording instruments become inoperative, the plant may be allowed to batch concrete manually or operate with manual recording for a period of not more than 48 working hours from the time of breakdown.
    - b. If at the end of 48 working hours, the plant is still not in operating order, the following shall be complied with:
      - 1) DEP shall be contacted and an independent inspector, other than the regular plant inspector shall be assigned to each batching operation at the plant, at no additional cost to the City.
      - 2) Additional inspectors shall observe and record the weight of each component of the batch.
      - 3) The manually recorded batch weights shall appear on a ticket presented to inspection personnel at the project site.
  6. Concrete producers shall have their plants inspected quarterly by NYSDOT.
  7. Concrete producers shall have their scales and trucks certified quarterly by NYSDOT.
- C. Batch Mixing at Site:
  1. The concrete shall be produced in a plant conforming to the requirements of the “Concrete Plant Standards” of the Concrete Plant Manufacturer’s Bureau and ACI 318, Section 5.8.3. Prior to erection of

such plant at the site, the contractor shall submit to the Supervising Engineer for Concrete Construction, for approval, all pertinent data relative to the plant.

2. All components of the plant must bear the proper rating plates issued by the Concrete Plant Manufacturers Bureau and the limitations thereon shall be strictly adhered to.
3. On job site plants for jobs requiring less than 1000 cubic yards of structural concrete or a job site plant that would operate for less than 30 working days duration, the requirements of Paragraph B.5 above for automatic batching and automatic recording will be waived. If at any time automatic proportioning devices or recording instruments become inoperative, follow the provisions of Paragraphs B.5.a and B.5.b.
4. The batch shall be so charged into mixer that some water will enter in advance of the cement and aggregates. Water shall continue to flow for a period which may extend to the end of the first 25 percent of the specified mixing time. Controls shall be provided to insure that the batch cannot be discharged until the required mixing time has elapsed. When concrete of normal weight is specified, controls shall be provided to insure that no additional water may be added during mixing. The entire batch shall be discharged before the mixer is recharged.
5. Each batch of 2 cu.yd. or less shall be mixed for not less than 1 1/2 minutes. The mixing time shall be increased 15 seconds for each additional cubic yard or fraction thereof. Shorter mixing time may be permitted provided performance tests made in accordance with ASTM C 94 indicate that the time is sufficient to produce uniform concrete. At least three quarters of the required mixing time shall take place after the last of the mixing water has been added. The interior of the mixer shall be free of accumulations that will interfere with mixing action. Replace mixer blades when they have lost 10 percent of their original weight.
6. When small quantities of concrete are produced on the site, measure solid materials by weight, and liquid or paste materials by weight or by volume. Mix all materials in a mechanical mixer. If packaged dry combined materials are used, they shall conform to the requirements of ASTM C 387, and shall be capable of satisfying the requirements of this Standard Specification.

D. Control of Admixtures:

1. Air entraining and chemical admixtures shall be charged into the mixture as a solution and shall be dispensed by an automatic dispenser or similar measuring device. The accuracy of measurement of any admixture shall be within  $\pm 3$  percent. Admixtures shall be charged into

the mixer in such manner as not to come into direct contact with the cement.

2. Two or more admixtures may be used in the same concrete provided such admixtures are added separately during the batching sequence and provided further that evidence is submitted to show that the admixtures used in that combination retain full efficiency and have no deleterious effect on the concrete or on the properties of each other.
3. All admixtures shall be added prior to mixing.

E. Structural Lightweight Concrete:

1. This section covers the requirements for production of structural lightweight concrete and appurtenances in structures. Portions of the structure to be treated as lightweight concrete under the provisions of this Section are so designated on the Contract Drawings. Lightweight concrete shall comply with all requirements of this Section unless otherwise specified in the General Specification.
2. Performance and Design Requirements:
  - a. Entrain air in lightweight concrete that will be exposed to freezing and thawing conditions. Use  $6 \pm 2$  percent total air content when the nominal maximum size of aggregate is greater than  $3/8$  in. Use  $7 \pm 2$  percent total air content when the nominal maximum size is  $3/8$  or less. Determine the air content by the volumetric methods of ASTM C 173. Select concrete mixture proportions for concrete to provide a compressive strength as required by the Contract Drawings.
  - b. Use ASTM C 150 Type II or Type V cement for lightweight concrete required to be chemical-resistant. Select concrete mixture proportions to provide a specified minimum compressive strength 4000 psi, unless otherwise specified on the Contract Drawings.
3. Mixtures:
  - a. Proportion lightweight concrete mixtures to meet the specified limit on maximum air-dry unit weight as determined by the method of ASTM C 567. Correlate the air-dry unit weight with the fresh unit weight of the same concrete to permit use of the latter as the basis for acceptance during construction.
  - b. Determine the cement factor needed to attain the required strength for lightweight concrete in accordance with the N.Y. City Administrative Building Code and relate strength to cement content of the concrete.

4. Batching and Mixing:
  - a. Batch and mix lightweight aggregate concrete as recommended by the aggregate producer and the concrete producer, and in accordance with this Section. If the procedure recommended by the aggregate producer and the concrete producer is at variance with this Section, submit the producers' recommendations to the Engineer for acceptance.
  - b. For low absorption aggregate, batch and mix aggregate that has been shown to absorb less than 2 percent water by weight during the first hour after inundation. Test aggregate for water absorption with the minimum moisture content likely to occur on the job. Pre-dampening may be used to achieve this condition.
  - c. For high absorption aggregate, batch and mix concrete made with lightweight aggregates absorbing 2 percent water by weight or more by:
    - 1) First, add the aggregate to approximate 80 percent of the mixing water and mix for a minimum of 1 1/2 minutes in a stationary mixer or 15 revolutions at mixing speed in a truck mixer.
    - 2) Then add any admixtures, the cement, and the withheld portion of mixing water and complete the mixing.
  - d. Additional water may be added to the mixture, if needed, to bring the mixture to the specified slump after truck transport. Increase the slump of concrete entering the pump as required to maintain the specified slump at the point of placement.
  - e. The lightweight aggregate shall be presoaked by vacuuming, ponding, or sprinkling continuously with water until the aggregate moisture content is sufficient to minimize slump loss through the pump line. Slump loss through the pump line shall not exceed 4 inches. The presoaking period shall be up to 30 days or as required by the Engineer after determination at the batch plant.
- F. Tempering and Control of Mixing Water:
  1. Concrete shall be mixed only at the mix plants or at the job site. Concrete shall be mixed in quantities not to exceed immediate job placement requirements.
  2. The addition of any water to the mix while the truck is en route from plant to job site is strictly prohibited. Mixing in transit is strictly

**GENERAL SPECIFICATION 03300 – CAST- IN-PLACE CONCRETE**

---

- prohibited. Agitating in transit is permitted, but shall be kept to a minimum.
3. When concrete arrives at the point of delivery with a slump below that which will result in the specified slump at the point of placement and is unsuitable for placing at that slump, the slump may be adjusted to the specified value by adding water if all the water required in the accepted mixture proportions has not been added at the start of mixing and if permitted by the Engineer. Addition of water shall be in accordance with ASTM C 94. Neither the specified water-cement ratio nor slump shall be exceeded. Do not make slump adjustments after 15 percent of the batch has been unloaded. Do not add water to concrete containing a plasticizing or a high range water reducing admixture. Do not add water to concrete in delivery equipment not acceptable for mixing. Measure air content of air-entrained concrete, after slump adjustment, to verify compliance to specified requirements.
  4. Each increment of water added at the job site must be incorporated by additional mixing by turning the drum not less than 30 revolutions. The addition of the increments of water and the start of the mixing procedures shall not be commenced earlier than one-half hour prior to the beginning of discharge. From the time the batch or load has been mixed to the specified slump, no further water shall be added to the concrete.
  5. Discharge of the concrete shall be completed within the limits set out in the following table. Time and drum revolution limits shall be measured from the introduction of any mixing water to the cement and aggregates or the introduction of the cement to the aggregates (ribbon loading).

<b>CONCRETE DISCHARGE REQUIREMENTS</b>	
<b>Concrete Temperature</b>	<b>Limit</b>
Over 90°F	Concrete shall be removed from site and discarded
85° to 90°F	1 hour or 300 revolutions, whichever comes first
80° to 85°F	1 hour 15 minutes or 300 revolutions, whichever comes first
70° to 80°F	1 hour 30 minutes or 300 revolutions, whichever comes first
Below 70°F	2 hours or 300 revolutions, whichever comes first

G. Weather Conditions:



1. Cold Weather:
    - a. To maintain the temperature of the concrete above the minimum placing temperature required by Article 3.04, Paragraph D.3 the as-mixed temperature shall not be less than 55°F when the mean temperature falls below 40°F. Follow the detailed recommendations given in “Cold Weather Concreting” (ACI 306R), where applicable.
    - b. If water or aggregate has been heated above 100°F, the water shall be combined with the aggregate in the mixer before cement is added. Cement shall not be added to mixtures of water and aggregate when the temperature of the mixture is greater than 90°F.
  2. Hot Weather:
    - a. The ingredients shall be cooled before mixing if necessary to maintain the temperature of the concrete below the maximum placing temperature required by Article 3.04, Paragraph D.3. The temperature of the concrete at initial discharge shall not exceed 85°F. Follow the detailed recommendations given in “Hot Weather Concreting” (ACI 305R), where applicable.
  3. Under special circumstances, and with written approval of the Supervising Engineer for Concrete Construction, the above provisions as to the initial discharge temperature of the concrete may be modified.
  4. Accelerators or retarders may be used with the approval of the Supervising Engineer for Concrete Construction. When permitted, they shall be used in accordance with “Hot Weather Concreting” (ACI 305R).
- H. Mixing Small Quantities of Concrete:
1. Only when permitted by the Supervising Engineer for Concrete Construction, small quantities of concrete may be mixed either by a small manually controlled portable mixer or by hand. In such cases, volumetric measurement of aggregates will be permitted.
  2. Concrete shall be hand mixed on a watertight platform. Cement and aggregates shall first be mixed dry until a uniform color is obtained. Water shall then be added and the entire mass turned over at least six times, or until the mixture is uniform and of the required consistency. Not more than one-half cubic yard of concrete shall be hand mixed in any batch.

## GENERAL SPECIFICATION 03300 – CAST- IN-PLACE CONCRETE

---

### 3.03 PREPARATION FOR CONCRETE

- A. All reinforcement, installation of waterstop, positioning of embedded items, and condition of formwork shall be inspected and approved by the Supervising Engineer for Concrete Construction prior to concrete placement. Contractor shall provide written notice of intention to place concrete a minimum of one (1) working day prior to placement.
- B. The Contractor shall provide the following preparation before placing of concrete.
  - 1. Hardened concrete and foreign materials shall be removed from the inner surfaces of the conveying equipment.
  - 2. Formwork shall have been completed in conformance with General Specification 03100 - Concrete Formwork; ice and standing water shall have been removed; reinforcement shall have been secured in place in conformance with General Specification 03210 - Reinforcing Steel; expansion joint material, anchors and other embedded items shall have been positioned. Concrete shall not be placed on frozen ground.
  - 3. Subgrade shall be watered sufficiently to achieve surface saturated density of subgrade materials.
  - 4. Soft spots in subgrade shall be removed and replaced with approved backfill materials.
  - 5. No concrete shall be placed until the entire preparation has been approved by the Supervising Engineer for Concrete Construction or his authorized representative.
  - 6. When high ambient temperatures necessitate protection of concrete immediately after placing or finishing, make provisions in advance of concrete placement for windbreaks, shading, fogging, sprinkling, ponding, or wet covering with a light colored material.
  - 7. During cold weather, make provisions in advance of concrete placement to maintain the temperature of the concrete above 55°F. Use heating, covering or other means adequate to maintain the required temperature without injury to concrete due to concentration of heat. Do not use combustion heaters during the first 24 hours unless precautions are taken to prevent exposure of the concrete to exhaust gases containing carbon dioxide.

### 3.04 CONCRETE PLACEMENT

- A. General:
  - 1. The Contractor shall provide concrete placement including preparation before placing, conveying, depositing, consolidation, weather protec-

tion, bonding, underwater concreting, and placing of grout and mortar according to the following requirements.

**B. Conveying:**

1. Concrete shall be handled from the mixer to the place of final deposit as rapidly as practicable by methods which will prevent separation or loss of ingredients and in a manner which will assure that the required quality of the concrete is obtained. Follow the detailed recommendations given in “Guide for Measuring, Mixing, Transporting, and Placing Concrete” (ACI 304), where applicable.
2. Conveying equipment shall be of size and design to insure a continuous flow of concrete at the delivery end and shall be approved. Conveying equipment and operations shall conform to the following requirements:
  - a. Conveying equipment shall contain no aluminum components.
  - b. Truck mixers, agitators, and non-agitating units and their manner of operation shall conform to the applicable requirements of Article 3.02.
  - c. Belt conveyors shall be horizontal or at a slope which will not cause segregation or loss. Protect concrete to minimize drying and effects of temperature rise. Use an acceptable discharge hopper at the discharge end to prevent segregation. Do not allow mortar to adhere to the return length of the belt.
  - d. Chutes shall be metal or metal-lined having rounded bottoms and shall have a slope not exceeding 1 vertical to 2 horizontal and not less than 1 vertical to 3 horizontal. Chutes more than 20 feet long and chutes not meeting the slope requirements may be used provided they discharge into a hopper before distribution.
  - e. Pump equipment shall be of suitable kind and adequate pumping capacity and shall be subject to approval by the Supervising Engineer for Concrete Construction. Placement shall be controlled so that segregation does not occur in the discharged concrete. Test cylinders for strength and tests for slump, temperature, and air content shall be made on samples of concrete taken at point of discharge from the pump line.
  - f. The provisions of Paragraph B.2.d shall apply to placement methods delivering concrete through lines using pneumatic air pressure.
  - g. The provisions of Paragraphs B.2.d and B.2.e are not applicable to gunned mortar applications.

C. Depositing:

1. Concrete shall be deposited continuously, or in lifts not to exceed 18 inches in thickness such that no concrete will be deposited on concrete which has hardened sufficiently to cause the formation of seams or planes of weakness within the section. If a section cannot be placed continuously, construction joints shall be located at points as provided for in the drawings or as approved. Placing shall be carried on at such a rate that the concrete which is being integrated with fresh concrete is still plastic. Concrete which has partially hardened or has been contaminated by foreign materials shall not be deposited. Temporary spreaders in forms shall be removed when the concrete placing has reached an elevation rendering their service unnecessary. They may remain embedded in the concrete only if made of metal or concrete and if prior approval has been obtained. Detailed recommendations are given in “Guide for Measuring, Mixing, Transporting, and Placing Concrete” (ACI 304R), where applicable.
2. Placing of concrete in supported elements shall not be started until the concrete previously placed in columns and walls is no longer plastic and has been in place at least two hours.
3. Concrete shall be deposited as nearly as practicable in its final position to avoid segregation due to rehandling or flowing. Concrete shall not be subjected to any procedure which will cause segregation.
4. Place concrete for beams, girders, brackets, column capitals, haunches, and drop panels at the same time as concrete for slabs.
5. When underwater placement is required or permitted, place concrete by a method acceptable to the Engineer. Deposit the fresh concrete so the concrete enters the mass of the previously placed concrete from within, displacing water with a minimum disturbance to the surface of the concrete.
6. Where a surface mortar is to be the basis of the finish, the coarse aggregate shall be worked back from the forms with a suitable tool so as to bring a full surface of mortar against the form, without the formation of excessive surface voids. All concrete shall be consolidated by internal vibration, spading, rodding, or forking so that the concrete is thoroughly worked around the reinforcement, around embedded items and into corners of forms, eliminating all air or stone pockets which may cause honeycombing, pitting or planes of weakness. Use internal vibrators of the largest size and power that can properly be used in the Work. Over-vibrating and use of vibrators to transport concrete within forms shall not be allowed. Vibrators shall be inserted and withdrawn at many points, approximately 18 in. apart. At each insertion, the duration

shall be sufficient to consolidate the concrete but not sufficient to cause segregation, generally from 5 to 15 sec. duration. A spare vibrator shall be kept on the job site during all concrete placing operations. Follow the detailed recommendations given in of ACI 309R, where applicable. Workers shall be experienced in use of the vibrators.

- a. External vibration shall only be used when explicitly permitted by the Supervising Engineer for Concrete Construction. Vibrating operations shall be continuous throughout the entire section where concrete is being deposited. Vibrators shall be clamped to the studs or wales or in pairs so that while one is vibrating the other can be shifted to insure constant vibration. External vibration shall conform to the requirements of ACI 309R.

7. Execution:

- a. Do not vibrate lightweight concrete to the point that large particles of aggregate float to the surface.
- b. Do not work lightweight concrete to the point that mortar is driven down and an excess of the lightweight aggregate appears at the surface.

8. Self-Supporting Floors and Roofs:

- a. Reinforced Concrete Beams and Girders shall be cast monolithically with adjoining arches.
- b. Canopies, Cornices and Marquees shall be monolithically cast with floor arches, with profiles true to indicated contours. Top surfaces of canopies and marquees shall be pitched to drain. Exposed soffits and edges shall be rubbed with carborundum stone and left clean and true.

D. Protection, Weather, Placing and Preparation of Forms:

1. Concrete placed during rain, sleet or snow, or when the mean daily temperature falls below 40°F or is expected to be below 40°F during placing or within 24 hours thereafter or rises above 90°F shall be adequately protected as provided in Article 3.05 and approval for placement shall be obtained from the Supervising Engineer for Concrete Construction.
2. Rainwater shall not be allowed to increase the mixing water nor to damage the surface finish.
3. Placing temperature:
  - a. When the mean daily temperature falls below 40°F, the minimum temperature of concrete as placed shall be 50°F.

Follow the detailed recommendations given in “Cold Weather Concreting” (ACI 306R), and in accordance with NYCBC Section 1905.12, where applicable.

- b. Concrete deposited in hot weather shall have a placing temperature which will not cause difficulty from loss of slump, flash set, or cold joints. The temperature of the concrete preferably should be less than 80°F and shall not exceed 90°F unless permitted by the Supervising Engineer for Concrete Construction. Loss of slump, flash set, or cold joints due to the temperature of the concrete as placed will not be acceptable. When the temperature of the steel is greater than 120°F, fog the steel forms and the reinforcement with water just prior to placing the concrete. Follow the detailed recommendations given in “Hot Weather Concreting” (ACI 305R) and in accordance with NYCBC Section 1905.13, where applicable.

4. Placing:

- a. Adequate skilled personnel and equipment shall be available to handle and place the concrete immediately upon delivery.
- b. Dry surfaces shall be wet down before commencing placement of concrete.
- c. Temperature of surfaces to receive concrete (earth, forms, reinforcing steel, etc.), should approximate the temperature of the concrete being placed.
- d. Evaporation rate of water from freshly placed concrete should be held to a minimum by:
  - 1) Shading of operations.
  - 2) Reducing air circulation in area of operations.
  - 3) Maintaining fog spray during operations.
- e. Cold Joints shall be avoided. This can be accomplished by:
  - 1) Providing adequate skilled personnel to handle and place the concrete immediately after its delivery to the forms at an acceptable temperature.
  - 2) Placing in layers thin enough and areas small enough so that vibration or working of the concrete will insure complete union of adjacent layers.
  - 3) Lengthening of setting time by use of approved water reducing retarders.

- 4) Placing a bulkhead at a suitable point where placement is stopped temporarily.
    - f. Loss of slump shall be kept at a minimum. This can be accomplished by:
      - 1) Minimum lapse of time between mixing and placing.
      - 2) Avoiding delays in batch mixing and truck dispatching.
      - 3) Job conditions and equipment (chutes, access runs, etc.) being organized to prevent additional mixing.
      - 4) Use of approved water reducing retarders.
  5. Preparation of forms:
    - a. All forms or surfaces (subgrades, reinforcing steel) to receive concrete, in addition to the normal requirements of tightness, soundness, being free of debris, etc., shall be:
      - 1) Protected against excessive air currents.
      - 2) Sprinkled systematically with cool water.
    - b. Note: Wetting down around the work will cool the surrounding air and increase the humidity, thus reducing temperatures and evaporation from the concrete.
- E. Bonding:
1. When specified, the surface of joints shall be prepared in accordance with General Specification 03290 - Joints in Concrete.
  2. The hardened concrete of joints between footings and walls or columns, between walls or columns and beams or floors they support, joints in unexposed walls and all other not mentioned below shall be dampened (but not saturated) immediately prior to placing of fresh concrete.
  3. The hardened concrete of horizontal construction joints in exposed work; horizontal construction joints in the middle of beams, girders or joints, and slabs; and horizontal construction joints in work designed to contain liquids shall be dampened (but not saturated) then thoroughly covered with a coat of neat cement mortar of similar proportions on vertical surfaces and at least 1/2 in. thick on horizontal surfaces. The fresh concrete shall be placed before the mortar has attained its initial set.
  4. Joints receiving an adhesive shall have been prepared and adhesive applied in accordance with the manufacturer's recommendations prior to placing of fresh concrete.

5. Surfaces of joints which have been obtained by the use of a chemical retarder shall have been prepared in accordance with the manufacturer's recommendations prior to placing of fresh concrete.
- F. Concreting Under Water:
1. Placing concrete in water will be permitted only when approved by the Supervising Engineer for Concrete Construction. Concrete deposited under water shall be carefully placed in a compacted mass in final position by means of a tremie, a closed bottom dump bucket or other approved means, and shall not be disturbed after being deposited. Special care must be exercised to maintain still water at the point of deposit. Concrete shall not be placed in running water. Underwater formwork shall be reasonably watertight. The consistency of the concrete shall be carefully regulated and special care shall be exercised to prevent segregation of materials. The method of depositing concrete shall be regulated to produce approximately horizontal surfaces.
  2. When a tremie is used, it shall consist of a tube having a diameter of not less than 10 in. and constructed in sections having flanged couplings fitted with gaskets. The tremie shall be supported to permit free movement of the discharge end over the entire top surface of the work and shall permit rapid lowering when necessary to choke off or retard the flow. The discharge end shall be entirely sealed at all times and the tremie tube kept full to the bottom of the hopper. When a batch is dumped into the hopper, the tremie shall be slightly raised, but not out of the concrete at the bottom, until the batch discharges to the bottom of the hopper. The flow shall then be stopped by lowering the tremie. The flow shall be continuous until the pour has been completed.
  3. When a bucket is used to place concrete in water, it shall have a capacity of not less than 1/2 cubic yard.
- G. Protection and Cleaning of Exposed Structural Steel:
1. The Contractor shall take all necessary precautions to prevent mortar and concrete splashes on the steel. The Contractor shall exercise care to prevent abrasion or scuffing of the paint on the structural steel while concrete is being formed, placed or stripped.
  2. The Contractor shall thoroughly clean the structural steel of all concrete drippings or other foreign matter that may have been deposited on the steel or on any other part of the structure as a result of his operations. All the work involved in thoroughly cleaning the steel shall proceed before concrete drippings have hardened. Immediately after the concrete has been placed, the Contractor shall clean the steel with water and/or such other additional means subject to the approval of the Supervising Engineer for Concrete Construction as may be necessary to



remove all mortar, concrete and other foreign matter that has been dropped, dripped, splashed or otherwise deposited on the steel as a result of his operations. It will be the contractor's obligation and responsibility to remove all foreign matter to the satisfaction of the Supervising Engineer for Concrete Construction.

3. After formwork has been removed, any concrete or other foreign material that may have been previously missed and that still remains on the steel shall be removed.

H. Concrete finishes shall conform to the requirements of General Specification 03350 - Concrete Finishes.

### 3.05 CONCRETE CURING AND PROTECTION

A. General:

1. Protect all freshly deposited concrete from premature drying, from weather elements, from defacement, from flowing water, and from mechanical injury. The concrete shall be maintained with minimal moisture loss at a relatively constant temperature for a period of time necessary for the hydration of the cement and proper hardening of the concrete in accordance with the requirements specified herein.
2. As soon as the concrete has been placed and horizontal top surfaces have received their required finish, provision shall be made for maintaining the concrete in a moist condition for at least a 7-day period thereafter except for high early strength concrete, for which the period shall be at least the first three days after placement. Horizontal surfaces shall be kept covered, and intermittent, localized drying will not be permitted.
3. Concrete curing shall be in accordance with NYCBC Section 1905.11

B. Curing Methods:

1. The Contractor shall use one of the following methods to insure that the concrete remains in a moist condition for the minimum period stated above.
  - a. Ponding or continuous fogging or sprinkling.
  - b. Application of mats or fabric kept continuously wet.
  - c. Continuous application of steam (under 150°F).
  - d. Application of sheet materials conforming to ASTM C 171.
  - e. If approved by the Engineer, application of a curing compound in accordance with Paragraph G.

## GENERAL SPECIFICATION 03300 – CAST- IN-PLACE CONCRETE

---

- f. High Early Strength concrete shall be maintained above 50°F and in a moist condition for at least the first 3 days. Accelerated curing of concrete shall comply with ACI 318, Section 5.11.3.
- C. The Contractor shall keep absorbent wood forms wet until they are removed. After form removal, the concrete shall be cured by one of the methods in paragraph B.
- D. Any of the curing procedures used in Paragraph B may be replaced by one of the other curing procedures listed in Paragraph B after the concrete is one-day old. However, the concrete surface shall not be permitted to become dry at any time.
- E. Curing Concrete under Cold Weather Conditions:
  - 1. Curing under cold weather conditions shall conform to the requirements of ACI 306.
  - 2. Stripping time for forms and supports shall be increased as necessary to allow for retardation in concrete strength caused by colder temperatures. This retardation is magnified when using concrete made with blended cements or containing fly ash or ground granulated blast furnace slag. Therefore, curing times and stripping times shall be further increased as necessary when using these types of concrete.
  - 3. The methods of protecting the concrete shall be approved by the Engineer and shall prevent local drying. Equipment and materials approved for this purpose shall be on the site in sufficient quantity before the work begins. The Contractor shall assist the Engineer by providing holes in the forms and the concrete in which thermometers can be placed to determine the adequacy of heating and protection. All such thermometers shall be furnished by the Contractor in quantity and type which the Engineer directs.
- F. Curing Concrete under Hot Weather Conditions:
  - 1. When air temperatures exceed 85°F, the Contractor shall take extra care in placing and finishing techniques to avoid formation of cold joints and plastic shrinkage cracking. If ordered by the Engineer, temporary sun shades and/or windbreakers shall be erected to guard against such developments, in addition to generous use of wet burlap coverings and fog sprays to prevent drying out of the exposed concrete surfaces.
  - 2. Curing and protection of the concrete shall begin immediately after completion of the finishing operation. Continuous moist-curing consisting of method 1a or 1b, listed in paragraph B is mandatory for at least the first 24 hours. Method 1b. may be used only if the finished surface is not marred or blemished during contact with the coverings.

3. At the end of the initial 24-hour period, curing and protection of the concrete shall continue for at least four (4) additional days using one of the methods listed in paragraph B.
  4. Curing procedures during hot weather conditions shall conform to the requirements of ACI 305.
- G. Use of Curing Compound:
1. Curing compound shall not be used on surfaces to receive subsequent coatings. Curing compound shall not be used on surfaces exposed to water in potable water storage tanks and treatment plants unless curing compound is certified in accordance with ANSI/NSF Standard 61.
  2. When permitted, the curing compound shall maintain the concrete in a moist condition for the required time period, and the subsequent appearance of the concrete surface shall not be affected.
  3. The compound shall be applied in accordance with the manufacturer's recommendations after water sheen has disappeared from the concrete surface and after finishing operations. The rate of application shall not exceed 300 square feet per gallon. For rough surfaces, apply in two directions at right angles to each other.
- H. Early Termination of Curing:
1. Moisture retention measures may be terminated earlier than the specified times only when at least one of the following conditions is met:
    - a. The strength of the concrete reaches 85 percent of the specified 28-day compressive strength in laboratory-cured cylinders representative of the concrete in place, and the temperature of the in-place concrete has been constantly maintained at 50 degrees Fahrenheit or higher.
    - b. The strength of concrete reaches the specified 28-day compressive strength as determined by accepted nondestructive methods or laboratory-cured cylinder test results.
    - c. Tests are made of cylinders kept adjacent to the structure and cured by the same methods and reach 70 percent of the specified compressive strength  $f_c$  as determined in accordance with ASTM C 39.
- I. Protection:
1. Floors which have received their final finish shall be closed to all traffic for at least 48 hours following the completion of trowelling. Thereafter, before the floor is subjected to any traffic, it shall be covered with paper

covering meeting the requirements of ASTM C 171. This protection shall be maintained as long as necessary to avoid damage to the floor.

2. During the curing period, and thereafter as conditions may require, the concrete shall be protected from damaging mechanical disturbances, particularly excessive load stresses, heavy shock, and excess vibration. All finished concrete surfaces shall be protected from damage caused by construction equipment, materials, or methods, and by rain or running water. Self-supporting structures shall not be loaded in such a way as to overstress the concrete.
3. Following removal of protective paper, the surface shall be protected from painting and other work. All stains shall be removed.

### 3.06 MASS CONCRETE

- A. Concrete sections 4 feet or more in the least dimension are termed mass concrete and shall conform to the special provisions of this article in addition to all applicable provisions of other articles in this Section. Mass concrete proportioning, placement, consolidation and curing shall be in accordance with ACI 304R, 309R, 211.1, and 207.1R.
- B. Additional requirements for heating, cooling, curing and protecting concrete sections more than 6 feet in the least dimension shall be as specified in the General Specifications. Consideration shall be given to temperature rise caused by the hydration of the cement. Large differences in temperature within the concrete shall be avoided.
- C. Proportioning and Mix Design:
  1. Materials and mix proportioning for mass concrete shall be in accordance with ACI 207.1 - Mass Concrete, latest edition. Type III Portland cement and accelerating type admixtures shall not be used.
  2. Selection of concrete aggregates for mass concrete is of paramount importance to the quality of the concrete and to the economy and durability of the structure. Aggregates shall conform to the requirements of ASTM C 88 and C 227. Aggregate size shall be in accordance with ASTM 467.
  3. The selection of the mix design should recognize that serious volume change stresses can be avoided by controlling the temperature drop of the concrete from the maximum to ambient. Avoidance of thermal shock is important in preventing surface cracks due to temperature gradients. The maximum internal temperature will depend upon the initial concrete temperature and the type and quantity of cementitious materials used.
  4. Mixes shall be designed using types and amounts of cement which will reflect lower internal temperatures. Optimum cement is only obtainable

by aggregate proportioning that reduces the volume of the void spaces and depends upon aggregate gradation. Minimum cement factors with maximum size aggregate, air entrainment and low water cement ratios should be used, to produce workable concrete and the specified strength.

D. Placement:

1. Concrete with lower than usual slump may be used, provided it can be properly placed and consolidated.
2. Placing Temperatures - Unless otherwise permitted or specified, the temperature of the concrete when deposited at the point of placement shall not exceed 70°F, nor be less than 35°F. When the temperature of the surrounding air is expected to be below 40 ° F during placing, or within 24 hours thereafter, the temperature of the concrete when deposited at the point of placement shall be in accordance with ACI 306R.1.
3. Concrete shall not be placed until the installation of the temperature monitoring system has been inspected and approved by the Engineer and adequate materials for the curing and thermal protection of the concrete are on the site.

E. Curing and Protection: The curing requirements for this Section shall apply as modified in this article.

1. The curing period shall be a minimum of 14 days.
2. Temperature Monitoring:
  - a. Thermocouples or thermistors shall be installed in mass concrete placements in sets of two located on a grid at a maximum spacing of 25 feet on center in each direction and no closer than 6 feet from any edge or 4 feet from any opening. One thermocouple shall be placed at mid-depth of the concrete placement and the second thermocouple shall be located directly above the first and 2 inches below the surface. Additional thermocouples shall be placed at exposed edges of concrete placements at 50 feet on center, at mid-depth, and 2 inches beneath the surface. Where cooling pipes are installed, thermocouples shall be located mid-way horizontally between the pipes.
  - b. Each wire lead shall extend a minimum of 6 feet out of the concrete and shall be securely labeled with the location of the corresponding sensor and a tracking number.
  - c. Placement plans showing all temperature sensors and manufacturer's installation instructions and operating manuals

for all related equipment shall be submitted to the Engineer for approval prior to concrete placement.

- d. Temperature monitoring shall continue during the curing period and until the internal temperature is within 25 degrees F of the ambient air temperature following the end of the curing period.
3. Thermal Control:
- a. At mass concrete placements, the curing water added shall not be colder than 30 degrees F below the interior temperature of the concrete. If necessary, curing water shall be heated.
  - b. For mass concrete, large differentials of temperature between the interior of the concrete and the exterior of the concrete shall be avoided. The maximum allowable temperature differential between the interior of the concrete (core) and the exterior of the concrete (surface) shall not be more than 35 degrees Fahrenheit. When the difference in temperature between the core and the surface (horizontal or vertical) exceeds 30 degrees Fahrenheit, insulation blankets shall be added in 1/2 inch layers as needed to prevent the difference from increasing. Joints in insulation blankets shall be staggered a minimum of 12 inches at adjacent layers. Insulation blankets shall be placed over curing mats and moisture retaining cover. If the addition of layers of insulation are not sufficient to limit the temperature gradient to 35 degrees Fahrenheit, the concrete placement shall be tented and heat shall be applied as needed to control the temperature gradient.
  - c. Thermal controls and protection shall be maintained until the interior concrete temperature is less than 35 degrees Fahrenheit greater than the average daily ambient air temperature.
  - d. The rate of cooling within the interior of the concrete shall be regulated to control the temperature drop to not more than 1 degree Fahrenheit in any period of one hour and 10 degrees Fahrenheit in any 24-hour period.
  - e. Where insulation blankets are provided over mass concrete, at the end of the curing period they shall be removed one layer at a time at such a rate that the temperature differential between the core and the surface never exceeds 35 degrees Fahrenheit and the cooling rate specified above is not exceeded, but not more than one layer in an 8 hour period.

### 3.07 FIELD QUALITY CONTROL

- A. Field Quality Control Testing:
  - 1. General:

- a. Unless required otherwise by the General Specifications, all field quality control testing of materials and the resulting concrete for compliance with the technical requirements of the specifications shall be performed by the Division Of Design Services of the Bureau of Engineering Design and Construction and/or it's QA/QC Consultant.
  - b. The use of these, or any, testing services shall in no way relieve the contractor of his responsibility to furnish materials and construction in full compliance with the contract documents. The contractor is required under this contract to provide concrete of the quality specified and it is hereby emphasized that the responsibility for so doing is solely and completely his. It shall be the Contractor's responsibility to work with the Supervising Engineer for Concrete Construction and the DEP designated Testing Laboratory and to keep himself fully informed of the Evaluation of the Compression Test results as described in Paragraph 3.07 B.
2. Testing Provided by DEP – at DEP's discretion, the following testing and inspection shall be provided.
- a. Secure production samples of materials at plants or stockpiles during the course of the work and test for compliance with the specifications unless otherwise noted in the Schedule of Mixes Proportioning and Testing of the General Specifications.
  - b. Provide the services of a qualified concrete technician at each location on the job site where concrete is being mixed and discharged from the mixer for the duration of the concrete placement.
  - c. Strength Tests: The Concrete Testing Laboratory provided by DEP shall conduct all strength tests (in accordance with ASTM C39). Strength tests of the concrete shall be conducted in accordance with the following procedures.
    - 1) Secure composite samples in accordance with ASTM C 172.
    - 2) Each strength test shall be obtained from a different batch of concrete on a representative, truly random basis, avoiding any selection of the test batch other than by a number selected at random before commencement of concrete placement.
    - 3) Additional concrete test cylinders shall be made from concrete taken out of the bucket, hopper or forms as

directed by the Supervising Engineer for Concrete Construction. These test cylinders shall be separate and distinct from those made from the mixer and shall be made from the same batch as the sample taken from the mixer. Where concrete is placed directly from the mixer into forms, without any intermediate conveyance, these additional cylinders will not be required.

- 4) When pumping or pneumatic equipment is used, samples shall be taken at the discharge end.
- 5) Compressive strength tests shall be conducted on a set of four specimens molded from each sample in accordance with ASTM C 31, and cured under standard moisture and temperature conditions in accordance with ASTM C 31.
- 6) Test two specimens at 7 days in accordance with ASTM C 39. Test two specimen at 3 days instead of 7 days when high early strength is required.
- 7) Test three specimens at 28 days in accordance with ASTM C 39. The 28-day test result shall be the average of the strengths of the three specimens, except that if one specimen in a test manifests evidence of improper sampling, molding or testing, it shall be discarded and the remaining two strengths averaged. Should more than one specimen in a test show any of the above defects, the entire test shall be discarded. When high early strength is required, the specimens shall be tested at 7 days instead of 28 days.
- 8) When the 7-day test results (3-day for high early strength) are below 65% of the specified strength and/or whenever the 28-day test results (7-day for high early strength) are below the specified strength, the specimens shall be kept intact and stored for a minimum of 30 days or until inspected by both the Supervising Engineer for Concrete Construction or his authorized representative and the contractor.
- 9) Written results of the compression test results shall be posted on the DEP's concrete database 24 hours following the test date on the following business day. The test results are available to the Supervising Engineer for Concrete Construction, the Engineer, Contractor and concrete supplier. A hard copy of the final result will be sent to the Resident Engineer.



10) Unless otherwise directed, all cylinders shall only be handled by DEP designated personnel.

d. Other Required Tests:

- 1) Check the slump, air content, concrete temperature, unit weight, yield, and water content of each sample of concrete to be used in molding strength test specimens.
- 2) Perform all other field testing of concrete as required by the New York City Building Code.
- 3) Slump testing shall be conducted in accordance with ASTM C 143.
- 4) Air content testing shall be conducted in accordance with either ASTM C 231 (Pressure Method) or ASTM C 173 (Volumetric Method) on concrete samples from which the compressive strength test specimens are made. Note that the chase indicator is not the approved ASTM volumetric test method. Air content testing of lightweight concrete shall be in accordance with ASTM C 173.
- 5) Additional tests of air content shall be performed on a regular and frequent basis for control as directed by the Supervising Engineer for Concrete Construction. A Chase indicator, calibrated at least once daily against the readings for air content obtained by methods outlined in Item 4) of this Paragraph may be used for additional testing. Use of the Chase Indicator alone will not be considered as having met the requirements of Item 1) of this Paragraph for checking air content.
- 6) Measurements of concrete temperature shall be performed in accordance with ASTM C 1064.
- 7) Unit Weight tests shall be made with a calibrated one-half (1/2) cubic foot bucket in accordance with ASTM C 138. On obtaining the unit weight, the yield shall be immediately computed as the ratio; weight of all the ingredients batched including the water added per cubic yard (from the batching ticket) divided by the unit weight determined times 27. Over-yielding or under-yielding by more than 2% are cause for concern and should be immediately investigated.
- 8) Water content testing shall be conducted in accordance with AASHTO TP 23.

**GENERAL SPECIFICATION 03300 – CAST- IN-PLACE CONCRETE**

---

- 9) Properly note and record the time of day when all tests were made and the corresponding results. Also, record from what truckloads the samples were taken, the class of concrete which the samples represent and exactly where the concrete represented by the sample was deposited in the structure.
- e. Frequency of Testing:
- 1) For buildings, make one strength test for each 50 Cu. Yd. or fraction thereof for each mix design placed in any one day except that a minimum of two tests will be made for each day’s placement.
  - 2) The minimum number of tests shown in the following table will be made for concrete used for all structures other than buildings.

<b>Total Cubic Yards of Concrete Placed During Day</b>	<b>Minimum Number of Strength Tests</b>
Up to 100	One for each 50 Cu. Yds.*
OVER 100 CU. YDS.	One for each 100 Cu.Yds.*
* or fraction thereof.	

- 3) The Supervising Engineer for Concrete Construction may require that additional tests be made.
- f. Additional Services: The DEP provided testing agency shall provide additional services to the extent deemed necessary by DEP and shall also perform the following services.
- 1) Inspect concrete batching, mixing, and delivery operations in accordance with inspection requirements of the administrative building code of the City of New York.
  - 2) Check batching and mixing operations.
  - 3) Review the manufacturer’s report of each shipment of cement, aggregates and reinforcing steel and/or conduct laboratory spot checks of these materials as received.

- 4) Inspect the location and dimension of the forms, the placing of the reinforcing steel and the placing, conveying and depositing of the concrete.
  - 5) Sample concrete at point of placement and other locations directed by the Supervising Engineer for Concrete Construction and perform required tests.
  - 6) Additional testing and inspection required because of changes in materials or mixture proportions requested by the Contractor. When required, such testing shall be performed at the Contractor's expense.
  - 7) Additional testing of materials or concrete occasioned by failure to meet specification requirements. When required, such testing shall be performed at the Contractor's expense.
3. Authority and Duties of the DEP provided Special Inspection Testing Agency:
- a. Special Inspections of concrete shall be in accordance with NYCBC Table 1704.4.
  - b. Technicians representing the testing agency shall inspect the materials and the manufacture of concrete and shall report their findings to the Supervising Engineer for Concrete Construction or his authorized representative and the Contractor.
  - c. When it appears that the material furnished or work performed by the Contractor fails to fulfill specification requirements, the technician shall immediately notify the Supervising Engineer for Concrete Construction or his authorized representative, and the Contractor of such failure.
  - d. The technician shall not act as foreman or perform other duties for the Contractor.
  - e. Technicians are not authorized to revoke, alter, relax, enlarge or release any requirement of the specifications, nor to approve or accept any portion of the work.
4. Responsibilities and Duties of the Contractor:
- a. Submit data and test documentation on materials and design mixtures including trial batch and shrinkage test results to the Engineer at least 60 days prior to the start of field operations.
  - b. Submittal to the Supervising Engineer for Concrete Construction the procedures, methods and concrete mix designs, the name and location of the proposed concrete plant. Submit the

- quality assurance programs of the concrete suppliers and provide copies of all test reports to the Engineer.
- c. Provide all materials, labor and equipment necessary to assist the representatives of the Owner's testing agency in obtaining, preparing and handling test samples at the project site or at other sources of material. When directed by the Engineer, the Contractor shall be responsible for transferring strength test specimens from point of casting to curing boxes and/or to testing agency vehicles.
  - d. Advise the Resident Engineer and the Supervising Engineer for Concrete Construction and the DEP provided Testing Agency sufficiently in advance of operations to allow for completion of quality tests and for the assignment of personnel.
  - e. Provide and maintain for the sole use of the testing agency adequate facilities for safe storage and proper curing of concrete test cylinders on the project site for the first 24 hours, as required by ASTM C 31. The Contractor shall provide an insulated box of substantial construction for use in storing cylinders on the site until such time as they are transported to the testing laboratory. The box shall be large enough to accommodate the maximum number of test cylinders which may be required for any day's concrete placement, and shall have an insulated hinged cover. Heating facilities shall be installed in the box such that the temperature within the box may be maintained at the limits specified by ASTM C 31. The box shall be of such dimensions as to permit placing the cylinders in the box one (1) high only. No stacking of cylinders will be permitted. A high-low thermometer shall be placed in the storage box and the maximum and minimum temperatures noted shall be recorded on an appropriate identification card for each test. To minimize the hazard of disturbance during curing, the storage box shall be located in an area free from vibration such as pile driving and traffic of all kinds. No concrete shall be delivered on the site until such storage curing box has been provided and any identified problems with the box addressed to the satisfaction of the Engineer. Cylinders shall remain in the curing box until ready for delivery to the testing laboratory but not less than 24 hours. Sufficient box storage capacity shall be provided by the Contractor to allow for up to 72 hours of cylinder storage.
  - f. The DEP provided Testing Agency shall deliver concrete test cylinders to the DEP designated testing laboratory, or such other location as designated in the General Specifications. Delivery

methods shall be in accordance with the requirements of ASTM C 31. Deliveries shall be made such that cylinders remain at the job site (in the boxes provided for their storage) no less than 24 hours and no more than 72 hours after the casting.

- g. The Contractor shall furnish copies of mill test reports of all shipments of cement, aggregates and reinforcing steel being used to Supervising Engineer for Concrete Construction and the testing agency.
- h. The Contractor shall be responsible for:
  - 1) All testing associated with the evaluation proposed mix designs including required trial batch and shrinkage testing.
  - 2) Establishing and controlling the mix proportions during the entire progress of the work in accordance with Paragraph 2.04.
  - 3) Testing required because of changes in materials or proportions of the mix requested by the contractor, as well as, any extra testing of concrete or materials occasioned by failure to meet specification requirements.

**B. Evaluation of Concrete Quality:**

**1. General:**

- a. Concrete quality shall include but not be limited to satisfactory strength, durability, density (air entrainment), wearing quality, shrinkage cracks, color, physical appearance etc.
- b. Wherever there is evidence that any of the concrete in place does not appear to produce the results required by the specifications, such concrete shall be considered questionable and evaluations shall be made as detailed below.

**2. Evaluation of Compressive Test Results:**

- a. Test results shall be evaluated separately, for each type and each specified strength of concrete. Evaluation shall be in accordance with the ACI 214.
- b. The strength level of an individual class of concrete shall be considered satisfactory if both of the following requirements are met:
  - 1) Every arithmetic average of any three consecutive compressive strength tests equals or exceeds the specified compressive strength  $f'_c$ .

- 2) No individual strength test (average of two cylinders) falls below the specified compressive strength  $f'_c$  by more than 500 psi when  $f'_c$  is 5,000 psi or less, or by more than 0.10  $f'_c$  when  $f'_c$  is more than 5,000 psi. The strength level of the concrete will be considered satisfactory as long as the averages of all sets of three consecutive compressive strength test results equal or exceed the specified compressive strength  $f'_c$  and no individual strength test result falls below the specified compressive strength  $f'_c$  by more than 500 psi.
  - c. For evaluation of the control of the quality and uniformity, each type and specified strength of the concrete shall be represented by at least five (5) tests.
  - d. If results of a number of consecutive seven (7) day tests at any stage of the work indicate abnormalities or results of a number of twenty-eight (28) day tests are below the specified strengths, the production and testing of the concrete shall be immediately investigated and reported upon by the Committee noted in Item 5 of Paragraph 3.07 B. It is emphasized that the report of the Committee is advisory. The responsibility for the production of the concrete and the decision as to how to proceed with the work remain with the Contractor. However, the decision as to how to proceed is subject to review and approval by the Commissioner.
3. Evaluation of Questionable In-Place Concrete Construction by Non-destructive Methods:
  - a. Visual inspection, impact hammers, sonoscopes, microscopic examination, chemical analysis of the hardened , probes or other nondestructive testing devices may be used as an indicator of the relative quality and uniformity of various areas of the structure, as an aide in evaluating concrete in place, or in determining locations of areas to be cored. Any program of nondestructive testing shall be performed as directed by and under the supervision of the Committee noted in Item 5 of Paragraph 3.07 B. Test results of any program of nondestructive testing and recommendations based thereon shall be reported by the Committee to the Commissioner prior to the commencement of any other program of further testing, if recommended or required. All viewpoints if there is no complete agreement, shall be noted in the report.
  - b. Nondestructive Tests:

- 1) Test results shall be evaluated and shall be valid only if tests have been conducted by properly calibrated equipment in accordance with recognized standard procedures.
  - 2) Nondestructive tests shall not be used as the sole basis for accepting or rejecting concrete.
4. Evaluation of Questionable In-Place Concrete Construction from Core Tests:
- a. Core tests shall be conducted only as recommended and directed by the Committee noted in Item 5 of Paragraph 3.07 B and only after a program of nondestructive testing as noted in Item 3 of Paragraph 3.07 B. Core tests shall be evaluated and shall be valid only if tests have been conducted in accordance with specified procedures.
  - b. When core testing is required, cores shall be obtained and tested in accordance with ASTM C 42. Cores shall be tested saturated-surface-dry or shall be tested air-dry depending as to whether the area where the questionable concrete is located shall be wet or dry under service conditions. Such determination shall be made by the Committee and they shall direct the condition of the cores at the time of testing. If the cores are to be tested dry, they shall be air dried (temperature 60 to 70 degrees F and relative humidity less than 60 percent) for seven (7) days before the test. If the cores are to be tested wet, they shall be tested after moisture conditioning in accordance with ASTM C 42. The laboratory report shall state whether the cores were tested saturated-surface-dry or surface-dry.
  - c. At least three representative cores shall be taken from each member or area of concrete in place that is considered potentially deficient. The location of cores will be determined by the Committee so as to least impair the strength of the structure.
  - d. If, before testing, one or more of the cores shows evidence of having been damaged subsequent to or during removal from the structure, or is obviously defective, replacement cores shall be taken.
  - e. Concrete in the area represented by a core test, made and tested in accordance with the specified requirements above will be considered adequate for structural strength if the average strength of the three cores taken from the immediate area of the questionable concrete is equal to or greater than the specified

strength and no single core strength is less than 85 percent of the specified strength ( $f_c$ ).

- f. The Committee shall determine the area where the cores are to be taken and they shall determine the number of cores to demonstrate the adequacy of the questionable concrete. Corrections to the strength values shall be made if the length to the diameter ratio is different from two. No strength correction shall be made for the age of the concrete cores.
  - g. If the average strength of the cores as tested is less than the required value, the Committee will make a recommendation as to whether the values obtained are acceptable or they will recommend that the values obtained be checked against a structural analysis as covered in Paragraph 3.07 C.
  - h. Core holes shall be plugged solid as specified.
5. Evaluation Committee:
- a. The following shall constitute a Committee for the investigation and the evaluation of the quality of the concrete when there are indications that the requirements of Paragraph 3.07 B are not being met. The Resident Engineer (who shall act as Chairman of the Committee), the Supervising Engineer for Concrete Construction or authorized representative, representatives of the Contractor, the Concrete Producer, the Testing Agency, the Architect/Engineer responsible for the design and such other members as the Commissioner may designate. Such members of the Committee as designated by the Chairman shall meet whenever request for such meeting is made by any member and/or as otherwise specified. Reports and recommendations of the Committee shall be submitted to the Contractor and the Commissioner. All viewpoints, if there is no complete agreement shall be noted in the report and reports shall be countersigned by all participating members of the Committee. The Contractor shall be responsible for the preparation and submission of reports.
  - b. The functions of the Committee and any reports, recommendations, etc., it submits shall be advisory in nature. The responsibility for the production and quality of the concrete remains solely and completely with the Contractor.
  - c. All expenses incurred due to the functioning of the Committee shall be borne by the Contractor except that all members of the Committee shall serve without fee.



6. Additional Curing:
  - a. If the concrete fails to meet the specified compressive strength requirements of this paragraph, additional curing as specified by the Supervising Engineer for Concrete Construction may be required and modifications may be required in the concrete mix design for the remaining concrete work, at the expense of the contractor, in addition to the measures outlined in Paragraph 3.07 B.
7. Acceptance of Concrete:
  - a. Concrete Strength:
    - 1) Concrete not meeting the requirements of Item 2 of Paragraph 3.07 B shall be considered potentially deficient. Steps shall be taken to increase the strength to ensure that the strength level will be satisfactory. For potentially deficient concrete, see Paragraph 3.07 C.
  - b. Air Content:
    - 1) Concrete not within the specified limits of air entrainment and tested in accordance with Paragraph 3.07 B shall be rejected.
    - 2) Steps must be made to control the proper air content.
  - c. Slump:
    - 1) Concrete not within the specified slump limits at the point of placement may be rejected.
    - 2) When the concrete is tested and found to be out of specifications the Contractor shall immediately adjust the mix to bring the mixture within the specified slump limits.
  - d. Acceptance of lightweight concrete shall be based on fresh unit weight measured in accordance with ASTM C 138. The nominal fresh unit weight shall be that corresponding to the specified maximum air-dry unit weight calculated from the formula for approximate air-dry weight in ASTM C 567. When the nominal fresh unit weight varies by more than 2 lb./ft. from the required weight, adjust the mixture as promptly as conditions permit to bring the unit weight to the desired level. Do not use any batch for which fresh unit weight varies by more than 3 lb./ft. from the desired level.

C. Acceptance of Structure:

1. General:

- a. Notwithstanding the provisions of any section of this “General Specification,” all concrete shall conform to the requirements of the New York City Building Code.
- b. Completed concrete work which meets all applicable requirements will be accepted without qualification.
- c. Completed Concrete work which fails to meet one or more requirements shall be considered potentially deficient. Potentially deficient concrete which has been repaired to bring it into compliance will be accepted without qualification. The decision as to whether it has been brought into compliance except as otherwise noted in this Section shall rest with the Supervising Engineer for Inspection subject to approval of the Commissioner and the Building Department.
- d. Potentially deficient concrete which cannot be brought into compliance shall be evaluated by the Committee noted in Paragraph 3.07 B and a report submitted to the Commissioner. The Commissioner will then, in writing, either accept without qualification or accept subject to Retainage (as outlined in Item 8 of Paragraph 3.07 C) or direct that the concrete be reinforced or supplemented with additional construction to bring it into compliance after which it may be resubmitted to the Commissioner.
- e. Repair potentially deficient concrete work by removing and replacing or by reinforcing with additional construction as required by the Engineer. To bring the rejected work into compliance, use repair methods that will maintain the strength of the structure and meet all other applicable requirements for function, durability, dimensional tolerances, and appearance.
- f. Obtain acceptance by the Engineer for repair methods and materials and for modifications needed to assure that concrete work complies with requirements in the Contract Documents.
- g. The Contractor shall pay all costs incurred including redesign and reverification in bringing the concrete work into compliance and acceptance.

2. Dimensional Tolerances:

- a. Formed surfaces resulting in concrete outlines smaller than required by an amount exceeding the requirements of Section

3.3 of ACI 347R shall be considered deficient in strength and subject to the provisions of Item 4 of Paragraph 3.07 C.

- b. Formed surfaces resulting in concrete outlines larger than required, by an amount exceeding the requirements of Section 3.3 of ACI 347R may be rejected and the excess material shall be subject to removal. If removal of the excess material is permitted, it shall be accomplished in such a manner as to maintain the strength of the section and to meet all other applicable requirements of function and appearance.
- c. Concrete members cast in the wrong location may be rejected if the strength, appearance or function of the structure is adversely affected or misplaced items interfere with other construction.
- d. Inaccurately formed concrete surfaces exceeding the requirements of Section 3.3 ACI 347R and which are exposed to view may be rejected and shall be repaired or removed and replaced if required.

3. Appearance:

- a. Concrete exposed to view with defects which adversely affect the appearance of the specified finish may be repaired, if possible. If, in the opinion of the Supervising Engineer for Concrete Construction, the defects cannot be repaired, the concrete shall be considered potentially deficient, such concrete shall be evaluated by the Committee noted in Paragraph 3.07 B and a report submitted to the Commissioner. The Commissioner will then in writing, either accept without qualification or accept subject to Retainage (as outlined in Item 8 of Paragraph 3.07 C) or direct that other remedial measures be taken after which it may be resubmitted to the Commissioner.

4. Strength of Structure:

- a. The strength of the structure in place will be considered potentially deficient if it fails to comply with any requirements which control the strength of the structure, including but not necessarily limited to the following conditions:
  - 1) Low concrete compression test strength as evaluated by Paragraph 3.07 B above. However, in those areas or members containing such concrete, if a structural analysis by the architect/engineer indicates the completed structure will be suitable for its intended use, i.e., that the stresses which will be developed under design load in the members containing below-strength

concrete are less than the design stress permitted for the actual compression test strengths reported and the analysis is approved by the Building Department, the member or members will be accepted without qualification.

- 2) Low concrete core tests as evaluated by Paragraph 3.07 B above. However, in those areas or members where core tests are made in accordance with Article 3.07 Paragraph B.4, if a structural analysis as specified in Item 1) above indicates the suitability of the structure for its intended use, i.e., that the stresses which will be developed under design load in the members containing below-strength concrete are less than the design stress permitted for the actual core test strengths reported, and the analysis is approved by the Building Department, the areas or members will be accepted without qualification.
  - 3) Reinforcing steel size, quantity, strength, position or arrangement at variance with the specified requirements or the project drawings.
  - 4) Concrete which differs from the required dimensions or location in such a manner as to reduce the strength.
  - 5) Curing less than specified.
  - 6) Inadequate protection of concrete from extremes of temperature during early stages of hardening and strength development.
  - 7) Mechanical injury, construction fires, accidents or premature removal of formwork likely to result in deficient strength.
  - 8) Poor workmanship likely to result in deficient strength.
5. Action Required When Strength Is Potentially Deficient:
- a. When the strength of the structure is considered potentially deficient, the following actions may be required by the Engineer/Architect:
    - 1) Structural analysis or additional testing or both may be required.
    - 2) Core tests may be required.
    - 3) If testing is inconclusive or impractical or if structural analysis does not confirm the Safety of the structure, load

tests may be required and their results evaluated in accordance with ACI 318.

- 4) Concrete Work rejected by structural analysis or by results of a load test shall be reinforced with additional construction as required by the Engineer/Architect, or replaced.
- 5) Document all repair work performed to bring strength-deficient concrete work into compliance with Contract Documents, and submit the documentation to the Engineer/Architect for acceptance.

6. Durability:

a. The durability of the concrete work will be considered deficient and therefore the concrete work shall be rejected, if it fails to comply with any of the requirements which control the durability of the structure, including, but not necessarily limited to, the following conditions:

- 1) Strength failing to comply with Paragraph 3.07 B above.
- 2) Materials for concrete not conforming with the specified requirements of Part 2 above.
- 3) Concrete not conforming with either the specified air-entrainment requirements or the air content limits.
- 4) Curing not accomplished in accordance with Contract Documents.
- 5) Inadequate protection of concrete from extremes of temperature during early stages of hardening and strength development.

7. Withholding:

a. Where concrete is placed which is considered to be deficient, whether in strength, appearance, durability or any other quality defined, payment may be withheld at the discretion of the Supervising Engineer for Concrete Construction. If such concrete is subsequently accepted without qualification, then payment shall be made for such concrete including return of all monies withheld.

8. Retainage:

a. Deficient concrete which cannot be brought into compliance and is nevertheless accepted by the Commissioner shall be subject to the following permanent retainage. For every cubic yard of

concrete so placed, an amount equal to 10% of the unit price for concrete in place for unit price contracts or 10% of the price established in the detailed estimate for concrete in place for lump sum contracts shall be permanently retained.

9. Rejected Concrete:
  - a. Concrete which has been rejected, in writing, by the Commissioner, shall be removed and replaced. The cost of all such removed and replaced concrete shall be borne by the Contractor.
10. Protection of In-Place Concrete:
  - a. Loading and Support of Concrete:
    - 1) Do not allow construction loads to exceed the superimposed load which the member, with necessary supplemental support, is capable of carrying safely and without damage. Submit for acceptance data on the amount of loading, method of distributing load, and any proposed supplemental support during construction.
  - b. Protection from Mechanical Injury:
    - 1) During the curing period, protect, the Contractor shall protect the concrete and its shoring from damaging mechanical equipment inducing shock and vibrations at all times. Protect all concrete surfaces from damage by construction traffic, equipment, materials, rain or running water, and other adverse weather conditions.

### 3.08 CONCRETE REPAIRS

- A. Repair of Formed Surfaces:
  1. The following defects shall be repaired in all types of formed finishes:
    - a. Spalls, air bubbles, rock pockets, form depressions, and other defects which are more than 1/4 inch in depth.
    - b. Holes from tie rods and other form tie systems.
    - c. Fins, offsets and other projections which extend more than 1/4" beyond the designated member surface.
    - d. Structural cracks, as defined by the Engineer.
    - e. Non-structural cracks, as defined by the Engineer, which are greater than 0.010 inches wide. In water retaining members, elevated slabs subject to rainfall and washdown, and below grade members, any crack which shows any amount of leakage.

Where it is not possible to verify that a crack is not leaking, it shall be repaired.

- f. Stains and substances marring the surface.
2. The following defects shall be repaired in smooth finish surfaces, in addition to those listed above:
- a. Spalls, air bubbles, rock pockets, form depressions, and other defects which extend to more than 1/2" in width in any direction, no matter how deep.
  - b. Spalls, air bubbles, rock pockets, form depressions, and other defects of any size which exceed 3 in number in a 12 inch square or 12 in number in a 3 foot square.
  - c. Fins, offsets and other projections shall be completely removed and smoothed.
  - d. Scratches and gouges in the surface.
  - e. Surfaces that exceed allowable tolerances.
  - f. Texture and color irregularities. At water retaining surfaces, texture and color irregularities need not be repaired when greater than 12 inches below the minimum normal operating water surface except where such defects are indicative of reduced durability.
3. Where a smooth rubbed or grout cleaned finish is specified, minor surface defects repairable by the finishing process need not be repaired prior to the finish application, when approved by the Engineer.
- B. Method of Repair of Formed Surfaces:
- 1. Repair and patch defective areas with cement mortar or concrete repair mortar immediately after removal of forms and as directed by Engineer.
  - 2. Repairs made to water bearing and below grade surfaces shall be made with repair mortar only. Repairs of form tie holes in water bearing or buried surfaces shall be made with non-shrink grout as specified in General Specification Section 03600 - Grout.
  - 3. Cut out honeycomb, rock pockets, voids, and holes left by tie rods and bolts, down to solid concrete but, in no case, to a depth of less than 1 inch for cement mortar and 1/2 inch for repair mortar. Make edges of cuts perpendicular to the concrete surface. Before placing the cement mortar, thoroughly clean and brush-coat the area to be patched with the specified bonding agent. Where concrete repair mortar is used, the surface shall be prepared and mortar placed per manufacturers

recommendations. Compact mortar in place and strike off slightly higher than the surrounding surface. Cure as specified.

4. Repairs to surfaces exposed to public view shall match the color and texture of surrounding concrete.
  5. Provide test areas at inconspicuous locations to verify mixture, texture and color match before proceeding with the patching.
  6. Structural cracks shall be pressure grouted using epoxy injection in accordance with the manufacturer's directions and recommendations.
  7. Non-structural cracks shall be pressure grouted using hydrophilic resin in accordance with the manufacturer's directions and recommendations.
  8. Fill holes extending through concrete by means of a plunger- type gun or other suitable device from the least exposed face, using a flush stop held at the exposed face to ensure completely filling.
  9. Remove stains, grout accumulations, sealing compounds, and other substances marring surfaces by scrubbing, power washing, or abrasive blast using sand finer than No. 30 and air pressure from 15 to 25 psi.
- C. Repair of Unformed Surfaces:
1. Test unformed surfaces, such as monolithic slabs, for smoothness and to verify surface plane to the tolerances specified for each surface and finish according to ACI 117. Correct low and high areas as herein specified.
  2. Test unformed surfaces sloped to drain for trueness of slope, in addition to smoothness, using a template having the required slope. Correct high and low areas as herein specified.
  3. Repair finish of unformed surfaces that contain defects which adversely affect the durability of the concrete. Surface defects include crazing, spalling, popouts, honeycomb, rock pockets, and other objectionable conditions.
  4. Repair structural cracks as defined by the Engineer in all structures.
  5. Repair non-structural cracks as defined by the Engineer which are greater than 0.01 inches wide, which are in below grade structures, or which are exposed to public view. In water retaining structures, repair any crack which shows any amount of leakage and all cracks where leakage potential cannot be determined.
- D. Methods of Repair of Unformed Surfaces:
1. Correct high areas in unformed surfaces by grinding, after the concrete has cured sufficiently so that repairs can be made without damage to adjacent areas.



2. Correct low areas in unformed surfaces during, or immediately after completion of surface finishing operations by cutting out the low areas and replacing with fresh concrete. Finish repaired areas to blend into adjacent concrete. Where the concrete has already set and repairs are required, sawcut around the perimeter of the area to be repaired to a 1/2-inch depth and remove concrete so that the minimum thickness of the repair is 1/2 inch. Apply specified concrete repair mortar in accordance with the manufacturer's directions and recommendations.
  3. Remove defective areas to sound concrete with clean, square cuts, to a minimum depth of 1.5 inches. Provide 3/4 inch clearance all around exposed reinforcing steel. Clean and dampen all concrete surfaces in contact with patching concrete and brush with the specified bonding agent. Place patching concrete while the bonding agent is still tacky. Mix patching concrete of the same materials and proportions to provide concrete of the same type or class and color as the adjacent finished concrete. Place, compact and finish as required to blend with adjacent finished concrete. Cure in the same manner as adjacent concrete.
  4. Repair isolated random non-structural cracks in members which are not below grade or water retaining, and single holes not over 1 inch diameter, by the dry-pack method. Groove the top of cracks, and cut out holes to sound concrete and clean of dust, dirt and loose particles. Dampen all cleaned concrete surfaces and brush with the specified bonding agent. Place dry-pack grout before the cement grout takes its initial set. Mix dry-pack grout as specified in Section 03600, Grout. Compact dry-pack mixture in place and finish to match adjacent concrete. Keep patched areas continuously moist for not less than 72 hours.
  5. Structural cracks shall be pressure grouted using an epoxy injection system. Apply in accordance with the manufacturer's directions and recommendations.
  6. Non-structural cracks in below grade and water retaining structures shall be pressure grouted using hydrophilic resin. Apply in accordance with the manufacturer's directions and recommendations.
  7. Where flooring material is to be installed, assure that surface is acceptable for flooring material to be installed in accordance with manufacturer's recommendations.
- E. Other Methods of Repair:
1. Repair methods not specified above may be used with written approval of the Engineer.

## **GENERAL SPECIFICATION 03300 – CAST- IN-PLACE CONCRETE**

---

### 3.09 SHOTCRETE

- A. Shotcrete is concrete or mortar pneumatically projected at high velocity onto a surface. Shotcrete proportioning, placement, curing and testing shall be in accordance with NYCBC Section 1913, where applicable.
- B. For projects where NYCBC is not applicable, ACI 506 and 506.2 guidelines shall be followed.

**“Table 1 -- Concrete Mix Requirements” is given in the following page**

**GENERAL SPECIFICATION 03300 – CAST- IN-PLACE CONCRETE**

**TABLE 1 - CONCRETE MIX REQUIREMENTS**

Classes of Concrete	Coarse Aggregate Sizes (ASTM C 33)			Minimum Cementitious Materials (lbs/cu yd.)	Cement Type (ASTM C 150)	Mineral Admixtures (%)		W/(C + P) Maximum	Specified Strength (psi)	
	A	B	C			A	B		f <sub>c</sub> minimum field condition	f <sub>cr</sub> minimum for mix design
50	#67 (3/4" to No. 4)	#8	---	705	III	---	---	0.42	5,000 AT 28 DAYS	6,500 at 28 days
45	#57 (1" to No. 4)	#8	---	660	II			0.42	4,500 at 28 days	5,850 at 28 days
45F	#4 (1.5" to 3/4")	#67	#8	660	II			0.41	4,500 at 56 days	5,850 at 56 days
40LW	3/4" to No. 4	---	---	660	I or II			0.45	4,000 at 28 days	5,200 at 28 days
45 w/ 3/8" aggregate	3/8" to No. 16	#8	---	660	II			0.40	4,500 at 28 days	5,850 at 28 days
25	#57 to #67	---	---	376	II			0.60	2,500 at 28 days	3,250 at 28 days

Note: Concrete containing coarse aggregate smaller than #67 shall only be used with the approval of the Engineer.

NO TEXT ON THIS PAGE

**CONCRETE PLACEMENT CARD**

<b>Contract:</b>		<b>Contractor:</b>	
<b>Placement Date:</b>		<b>Concrete Mix:</b>	
<b>Scheduled Start Time:</b>		<b>Approximate Quantity:   cu. yds.</b>	
<b>Identification of Placement:</b>			
<b>Placement No:</b>			
Item	Initials	Date	Remarks
	Inspector		
Foundations			
Construction Joint Preparation			
Forms and Blockouts			
Waterstops			
Reinforcement			
Embedments/Anchor Bolts			
Piping/Test			
Temperature Checkout			
Cleanup			
Provisions for Weather			
<b>Contractor</b>			
Electrical Contractor			
HVAC Contractor			
Plumbing Contractor			
Structures Contractor			

NO TEXT ON THIS PAGE



# Mix Design Proportions Summary Sheet MDS

**- USE ONE FORM PER MIX DESIGN -**

Contract:		Mix Design Code (DEP Only):	Class (Specified Strength): PSI + %		Proposed Trial Batch Date:	Submittal Date:					
Contractor:		Concrete Supplier:			Testing Laboratory:						
Mix Description (Common Name):		Concrete Supplier Address:			Testing Laboratory Address:						
		City:	State:	Postal Code:	City:	State:	Postal Code:				
Expedite: <input type="checkbox"/> Yes (Comment Reqd.) <input type="checkbox"/> No	Application: <input type="checkbox"/> Structural <input type="checkbox"/> Non-structural	Field Inspection: <input type="checkbox"/> Yes (Controlled) <input type="checkbox"/> No (Uncontrolled)	Weight Type: <input type="checkbox"/> Normal <input type="checkbox"/> Lightweight		Fly Ash: <input type="checkbox"/> Yes, List %: <input type="checkbox"/> No	Field Curing: <input type="checkbox"/> Yes, Min. Days: <input type="checkbox"/> No					
Specimen Transport, Testing & Disposal Ages (Use Comments Area, If Applicable):		No. of Specimens (Per Set)	Transport Age (Days)	Test Age (No. of Specimens at Days)						Disposal Age for Unused Specimens (Days)	
				Preliminary		Final		Other(s)			
<input type="checkbox"/> Yes <input type="checkbox"/> No CQAP Standard		5	2	Qty	Days	Qty	Days	Qty	Days	28	
<input type="checkbox"/> Yes <input type="checkbox"/> No Other:											
<b>Cement /Slag /Fly Ash</b>											
Grade/Class:				Source:				PCY:			
<b>Cement/Slag /Fly Ash</b>											
Grade/Class:				Source:				PCY:			
<b>Crushed Stone</b>											
Size Number:				Source:				PCY (SSD):			
<b>Crushed Stone</b>											
Size Number:				Source:				PCY (SSD):			
<b>Sand</b>											
Type:				Source:				FM:	PCY (SSD):		
<b>Water</b>											
							PCY:	GAL/CY:			
<b>Air Entraining Admixture</b>											
Designation:				Brand:				OZ/CY:			
<b>-Range Water Reducing Agent</b>											
Designation:				Brand:				OZ/CY:			
<b>Water-Reducing/Retarding Agent</b>											
Designation:				Brand:				OZ/CY:			
<b>Other Admixtures</b>											
Designation:				Brand:				OZ/CY:			
Designation:				Brand:				OZ/CY:			
Designation:				Brand:				OZ/CY:			
Specified Slump (IN):	Specified Air Content (%):	Yield (CY):	Theoretical Unit Weight (PCF):	Water-Cement Ratio (from trial batch):							
<b>Comments:</b>											
<b>- SUBMIT To NYCDEP CQAP At 1-800-673-2816 -</b>											
Submitted By (Print):			Testing Laboratory:			Signature:			Date:		



# Mix Design Submittal of Proportions MDS

Contract:	Mix Design Code (DEP Only):	Class (Specified Strength): PSI + %	Proposed Trial Batch Date:	Submittal Date:
Contractor:	Concrete Supplier:	Testing Laboratory:		

**Cement (ASTM C150)**

Type:	Sp. Gr.:	Class/Grade:	Source:	Total Mass Per CY (PCY):	Volume (CU FT):
-------	----------	--------------	---------	--------------------------	-----------------

**Other Cementitious Materials (ASTM C18)**

Type:	Sp. Gr.:	Class/Grade:	Source:	Total Mass Per CY (PCY):	Volume (CU FT):
-------	----------	--------------	---------	--------------------------	-----------------

**Aggregate No. 1, Fine (ASTM C33)**

Type:	SSD Sp. Gr.:	Size:	Source:	Total Mass Per CY (PCY):	Volume (CU FT):
Dry Rodded Unit WT (PCF):		Absorption (%):		FM:	

**Aggregate No. 2, Coarse (ASTM C33)**

Type:	SSD Sp. Gr.:	Size:	Source:	Total Mass Per CY (PCY):	Volume (CU FT):
Dry Rodded Unit WT (PCF):		Absorption (%):			

**Aggregate No. 3, 4 Coarse (ASTM C33)**

Type:	SSD Sp. Gr.:	Size:	Source:	Total Mass Per CY (PCY):	Volume (CU FT):
Dry Rodded Unit WT (PCF):		Absorption (%):			

**Aggregate No. 2, Lightweight Alternative (ASTM C330)**

Type:	Sp. Gr. Factor:	Size:	Source:	Oven Dry (PCY):	Volume (CU FT):
Loose Unit WT (PCF):		Estimated Wet (PCF):			

**Chemical Admixtures (oz/cy)**

No. 1 ASTM C:	Type:	Source:	Name:	WT (oz):
No. 2 ASTM C:	Type:	Source:	Name:	WT (oz):
No. 3 ASTM C:	Type:	Source:	Name:	WT (oz):

**Water (Total)**

GAL:	PCY:	CU FT:	<b>Air Content</b>	%	CU FT:	<b>Total Mixture Mass and Volume</b>	LB/CU FT:	CU FT:
------	------	--------	--------------------	---	--------	--------------------------------------	-----------	--------

**Comments:**

<b>Submitted By (Print):</b>	<b>Company:</b>	<b>Signature:</b>	<b>Date:</b>
------------------------------	-----------------	-------------------	--------------





# Mix Design Aggregates Gradation MDS

Sieve Size	Percent Passing Aggregate No.								Combined Gradation
	1 (Fine)		2 (Coarse) Stone Size (no): _____		3 (Coarse) Stone Size (no): _____		4 (Coarse) Stone Size (no): _____		
	Per ASTM C33:	Tested:	Per ASTM C33:	Tested:	Per ASTM C33:	Tested:	Per ASTM C33:	Tested:	
<b>3 IN</b>									
<b>2 1/2 IN</b>									
<b>2 IN</b>									
<b>1 1/2 IN</b>									
<b>1 IN</b>	-								
<b>3/4 IN</b>	-								
<b>1/2 IN</b>	-								
<b>3/8 IN</b>	<b>100</b>								
<b>1/4 IN</b>	-								
<b>#4</b>	<b>95-100</b>								
<b>#8</b>	<b>80-100</b>								
<b>#16</b>	<b>50-85</b>								
<b>#30</b>	<b>25-60</b>								
<b>#50</b>	<b>5-30</b>								
<b>#100</b>	<b>0-10</b>								
<b>Dry Unit WT (PCF)</b>									
<b>Absorption (%)</b>									
<b>FM</b>									

**Remarks:**



# Mix Design Trial Batches Proportions MDS

Material (Trial Batch Proportions Per Cubic Yard)			Trial Batch No.			
			#1	#2	#3	#4
<b>1. Cement</b>						
Type:	Source:	LB:	LB:	LB:	LB:	
<b>2. Other Cementitious Material</b>						
Type:	Source:	LB:	LB:	LB:	LB:	
Grade/Class:						
<b>3. Aggregate No. 1 (Fine) SSD</b>						
Type:	Source:	LB:	LB:	LB:	LB:	
Sp. Gr.:	FM:	Absorption (%):				
<b>4. Aggregate No. 2 (Coarse) SSD</b>						
Type:	Source:	LB:	LB:	LB:	LB:	
Sp. Gr.:	Size:	Absorption (%):				
<b>5. Aggregate No. 3 &amp; 4 (Coarse) SSD</b>						
Type:	Source:	LB:	LB:	LB:	LB:	
Sp. Gr.:	Size:	Absorption (%):				
<b>6. Aggregate No. 2 (Lightweight, Alternative)</b>						
Type:	Source:	Oven Dry:				
		LB:	LB:	LB:	LB:	
Sp. Gr.:	Size:	Absorption (%):	Wet:			
			LB:	LB:	LB:	
<b>7. Water (Total):</b>		LB:	LB:	LB:	LB:	
<b>8. Water-Cementitious Ratio:</b>						
<b>9. Chemical Admixtures</b>						
No. 1 Type:		WT (oz):	WT (oz):	WT (oz):	WT (oz):	
No. 2 Type:		WT (oz):	WT (oz):	WT (oz):	WT (oz):	
No. 3 Type:		WT (oz):	WT (oz):	WT (oz):	WT (oz):	
<b>10. Total Mass</b>		LB:	LB:	LB:	LB:	
<b>11. Total Mass Per Cubic Foot</b> (Theoretical Unit Weight)		PCF:	PCF:	PCF:	PCF:	



# Mix Design Mixture Properties MDS

Properties	ASTM	Target Per Specification	Trial Batch No.			
			#1	#2	#3	#4
<b>1. Fresh Concrete</b>						
Temperature (F):	C1064					
Slump (IN):	C143					
Before Add HRWR						
End of Mixing						
15 (MIN)						
30 (MIN)						
45 (MIN)						
1 (HR)						
Unit WT (PCF):	C138					
Air Content (%):	C231/C173					
Mortar Content (%):						
Yield (CU FT/CU YD):						
Water-Cementitious Ratio						
Time of Set (MIN):	C403					
Initial (MIN):						
Final (MIN):						
Difference (MIN):						
<b>2. Hardened Concrete</b>						
Cylinder No.			1 (A- )	2 (A- )	3 (A- )	4 (A- )
Compressive Strength (PSI):	C39/C192					
<b>3 Days</b>						
Specimen 1						
Specimen 2						
Average						
<b>7 Days</b>						
Specimen 1						
Specimen 2						
Average						
<b>28 Days</b>						
Specimen 1						
Specimen 2						
Specimen 3						
Average						



# Mix Design Mixture Properties MDS

Properties	ASTM	Target Per Specification	Trial Batch No.			
			#1	#2	#3	#4
56 Days (If Required by Contract Only)						
Specimen 1						
Specimen 2						
Average						
Shrinkage (%):	C157					
____ Days						
Specimen 1						
Specimen 2						
Average						
____ Days						
Specimen 1						
Specimen 2						
Average						
Observations						
Color						
Bleeding						
Heat Signature <small>(If Specified in the Specification and for the Submitted Batch Only)</small>						
<b>Trial Batch No. (Submitted and Recommended for Approval):</b>						
<b>Comments:</b>						
<b>Laboratory Director (Print):</b>		<b>Company:</b>	<b>Signature &amp; Seal:</b>	<b>Date:</b>		
<b>CQAP WITNESS (Print):</b>		<b>Company:</b>	<b>Signature:</b>	<b>Date:</b>		
<b>Contractor (Print):</b>		<b>Company:</b>	<b>Signature:</b>	<b>Date:</b>		
<b>Designer Of Record (Print):</b>		<b>Company:</b>	<b>Signature:</b>	<b>Date:</b>		



# Mix Design

## Laboratory Trial Batch Mix Design Data

### MDS

- TO BE COMPLETED BY CQAP -

Contract No.	Contract Name:	Basic Description of Specified Mix Design (Mix Design Common Name):				Trial Batch Date:									
Batch Plant Name:	Design Trial Lab Name:	Class (Specified Strength): PSI + %		Weight Type: <input type="checkbox"/> Normal <input type="checkbox"/> Lightweight		Concrete Type: <input type="checkbox"/> Pump <input type="checkbox"/> Conventional									
Description				Weight Per Cubic Yard											
Mix Point No.:				1	2	3	4								
Cement:		LBS													
Cementitious:		LBS													
Sand:		LBS													
Stone:		LBS													
Stone:		LBS													
Water:		GAL													
Water:		LBS													
Admixture:		Air	OZ												
Admixture:		HRWR/MRWR	OZ												
Unit Weight:			PCF												
Description				Laboratory Trial Batch Weights											
Mix Point No.:				1	2	3	4								
Cement:		LBS													
Cementitious:															
Sand:		LBS													
Stone:		LBS													
Stone:		LBS													
Water:		LBS													
Admixture:		Air	ML												
Admixture:		HRWR/MRWR	ML												
Description				Trial Batch Results											
Mix Point No.:				1		2		3		4					
Time:				Initial	30 MIN	Initial	30 MIN	Initial	30 MIN	Initial	30 MIN				
Slump:		IN													
Water Content:		LBS													
Water Used:		LBS													
Computed Mix Water:		LBS													
Total Mix Water:		LBS													
Unit Weight:		LBS													
		PCF													
Air:		%													
Temp:		DEG													
Actual W/C Ratio															
<b>Comments:</b>															
<b>CQAP WITNESS (Print):</b>				<b>Company:</b>				<b>Signature:</b>				<b>Date:</b>			



# Mix Design Trial Batch Strength Test Results Form ASTM C39/ C192

**- TO BE COMPLETED BY CQAP -**

Contract No.	Contract Name:	Design Trial Lab Name:	Class (Specified Strength):  PSI + %	Trial Batch Date:
--------------	----------------	------------------------	--	-------------------

**Preliminary Strength Testing (See Page 1 for Preliminary Strength Age):**

Age of Specimen:	Trial Batch #1 (Maximum Load / PSI)	Trial Batch #2 (Maximum Load / PSI)	Trial Batch #3 (Maximum Load / PSI)	Trial Batch #4 (Maximum Load / PSI)
Testing Date:	# 1	# 2	# 3	# 4
Specimen 1				
Specimen 2				
Specimen 3				
Average				

**Comments:**

CQAP WITNESS (Print): \_\_\_\_\_ Company: \_\_\_\_\_ Signature: \_\_\_\_\_ Date: \_\_\_\_\_

**Final Strength Testing (See Page 1 for Final Strength Age):**

Age of Specimen:	Trial Batch #1 (Maximum Load / PSI)	Trial Batch #2 (Maximum Load / PSI)	Trial Batch #3 (Maximum Load / PSI)	Trial Batch #4 (Maximum Load / PSI)
Testing Date:	# 1	# 2	# 3	# 4
Specimen 1				
Specimen 2				
Specimen 3				
Average				

**Comments:**

CQAP WITNESS (Print): \_\_\_\_\_ Company: \_\_\_\_\_ Signature: \_\_\_\_\_ Date: \_\_\_\_\_

**CQAP CPM Comments (Preliminary & Final Age Testing):**

CQAP CPM (Print): \_\_\_\_\_ Company: \_\_\_\_\_ Signature: \_\_\_\_\_ Date: \_\_\_\_\_



# Mix Design Trial Batch Strength Test Results Form ASTM C39/ C192

- TO BE COMPLETED BY CQAP -

Contract No.	Contract Name:	Design Trial Lab Name:	Class (Specified Strength):  PSI + %	Trial Batch Date:
--------------	----------------	------------------------	--	-------------------

Additional Strength Testing:				
Age of Specimen:	Trial Batch #1 (Maximum Load / PSI)	Trial Batch #2 (Maximum Load / PSI)	Trial Batch #3 (Maximum Load / PSI)	Trial Batch #4 (Maximum Load / PSI)
Testing Date:	# 1	# 2	# 3	# 4
Specimen 1				
Specimen 2				
Specimen 3				
Average				

**Comments:**

CQAP WITNESS (Print):	Company:	Signature:	Date:
-----------------------	----------	------------	-------

Additional Strength Testing:				
Age of Specimen:	Trial Batch #1 (Maximum Load / PSI)	Trial Batch #2 (Maximum Load / PSI)	Trial Batch #3 (Maximum Load / PSI)	Trial Batch #4 (Maximum Load / PSI)
Testing Date:	# 1	# 2	# 3	# 4
Specimen 1				
Specimen 2				
Specimen 3				
Average				

**Comments:**

CQAP WITNESS (Print):	Company:	Signature:	Date:
-----------------------	----------	------------	-------

**CQAP CPM Comments (Preliminary & Final Age Testing):**

CQAP CPM (Print):	Company:	Signature:	Date:
-------------------	----------	------------	-------

**GENERAL SPECIFICATION 03300 – CAST- IN-PLACE CONCRETE**

---



**SECTION 03350  
Concrete Finishes**

**PART 1 GENERAL**

**1.01 SECTION INCLUDES**

- A. Furnish all materials, labor, and equipment required to provide finishes of all concrete surfaces specified herein and shown on the Drawings.
- B. The following index of this Section is included for convenience:

<u>Article</u>	<u>Title</u>	<u>Page</u>
		03350-
PART 1	GENERAL .....	1
1.01	Section Includes .....	1
1.02	Payment.....	1
1.03	References.....	1
1.04	Submittals .....	2
1.05	Quality Assurance.....	2
1.06	Delivery, Storage And Handling.....	2
PART 2	PRODUCTS.....	3
2.01	Concrete Floor Sealer .....	3
2.02	Concrete Floor Hardener.....	3
2.03	Non-Slip Shake-On Aggregate .....	4
PART 3	EXECUTION.....	4
3.01	Finishes On Formed Concrete Surfaces.....	4
3.02	Slab And Floor Finishes .....	6
3.03	Sealing Of Concrete Floor .....	8
3.04	Finishes On Equipment Pads .....	8
3.05	Concrete Finish Schedule .....	8

**1.02 PAYMENT**

- A. Unless otherwise provided in the Detailed Specifications, no separate payment will be made for performing any Work required under this Section and the Contractor shall include all costs thereof in its lump sum price bid for the Contract.

**1.03 REFERENCES**

- A. Codes and standards referenced in this Section include:
  - 1. New York City Building Code.
  - 2. ACI 301 - Specifications for Structural Concrete for Buildings
  - 3. ACI 318 - Building Code Requirements for Structural Concrete

1.04 SUBMITTALS

- A. The Contractor shall submit Shop Drawings and material specifications for the approval of the Engineer. Submittals shall include, but not be limited to:
  - 1. Material certifications and technical data sheets.
  - 2. Manufacturer's literature containing instructions and recommendations on the mixing, handling, placement, and appropriate uses for each type of material used in the work.

1.05 QUALITY ASSURANCE

- A. Erect, on the site where directed, a full size mock-up of a cast-in-place wall or panel a minimum of 4 feet high, 4 feet from the corner on two sides, 12 inches thick or as shown in the Contract Drawings conforming to ACI 303.
  - 1. Reinforce the panel as shown in the Contract Drawings. Use form ties the same as those approved and with the form tie pattern similar to that approved. Use one face for the panel for smooth architectural concrete including "reveal" rustication with form joints, and the opposite face for form liner concrete.
  - 2. Plug the tie holes as specified to determine the correct mortar mixture to match the panel color. If required, remove and replace tie hole plugging mortar until an acceptable color match is obtained. After the sample panels have been approved, intentionally damage and patch portions of the finish surface of the panels for the purpose of determining the correct mixture for patching mortar and patching technique to match the original panel color and surface.
  - 3. Leave the approved mock-up on the job during construction as the standard of workmanship for the project. Remove mock-up from the premises after completion of the work.

1.06 DELIVERY, STORAGE AND HANDLING

- A. General: Failure to comply with the following shall be sufficient cause for rejection of materials by Engineer and his requiring its removal from the site. Supply new material at no additional expense to the City.
- B. Delivery of Materials:
  - 1. Deliver materials in manufacturer's original unopened and undamaged containers, with information accurately representing container contents as approved by the Engineer at time of Working Drawing submission.
  - 2. Include the following information on the label:
    - a. Name of material and supplier.
    - b. Installation, handling and protection requirements.

3. Deliver materials in sufficient quantities to allow uninterrupted continuity of the work.
- C. Storage of Materials:
1. Store only approved materials on project site.
  2. Store materials in original, undamaged containers with manufacturer's labels and seals intact.
  3. Store all materials in a dry, enclosed area, off the ground and away from all possible contact with water and in a location where temperature can be constantly maintained between 60F and 75F and out of direct sunlight.
  4. Prevent damage to materials during storage primarily by minimizing the amount of time they are stored at the job-site before being incorporated into construction systems.

## PART 2 PRODUCTS

### 2.01 CONCRETE FLOOR SEALER

#### A. MANUFACTURERS

1. Floor sealer shall be:
  - a. Sonoglaze HS as manufactured by Sonneborn, Parsippany, NJ.
  - b. Masterseal 330 as manufactured by Master Builders Solutions, Shakopee, MN.
  - c. Eucothane as manufactured by Euclid Chemical, East Brunswick, NJ.
  - d. Or approved equal.

### 2.02 CONCRETE FLOOR HARDENER

#### A. MANUFACTURERS

1. Liquid Floor hardener shall be:
  - a. Lapidolith as manufactured by by Sonneborn, Parsippany, NJ.
  - b. Pena-Lith as manufactured by W.R. Meadows, Hampshire, IL.
  - c. Hornolith as manufactured by Tamms Industries, Cleveland, OH.
  - d. Surfhard as manufactured by Euclid Chemical Company, East Brunswick, NJ.
  - e. Or approved equal.
2. Aggregate floor hardener shall be non-metallic. Hardener shall be:

- a. Harcol, as manufactured by Sonneborn, Parsippany, NJ.
- b. Maximent as manufactured by Master Builders Solutions, Shakopee, MN.
- c. Surfex as manufactured by Euclid Chemical, East Brunswick, NJ.
- d. Or approved equal.

2.03 NON-SLIP SHAKE-ON AGGREGATE

A. MANUFACTURERS

- 1. Shake-on aggregate for non-slip floors shall be non-metallic. Shake-on aggregate shall be:
  - a. Frictex NS as manufactured by Sonneborn, Parsippany, NJ.
  - b. A-H Alox as manufactured by Anti-Hydro, Flemington, NJ.
  - c. Non-Slip as manufactured by Euclid Chemical East Brunswick NJ.
  - d. Or approved equal.

PART 3 EXECUTION

3.01 FINISHES ON FORMED CONCRETE SURFACES

- A. After removal of forms, the finishes described below shall be applied in accordance with Article 3.05 - Concrete Finish Schedule. Unless the finish schedule, Contract Drawings, or Detailed Specifications specifies otherwise, all surfaces shall receive at least a Type I finish. The Engineer shall be the sole judge of acceptability of all concrete finish work.
  - 1. Type I - Rough or Board Form Finish: All fins, burrs and other projections left by the forms shall be removed. All holes left by removal of ties, and all other holes, depressions, or voids shall be filled solid with cement grout after first being thoroughly wetted. Honeycombs shall be chipped back to solid concrete as directed, prior to patching with cement grout. Holes shall be filled with a small tool that will permit packing the hole solidly with cement grout. Cement grout shall consist of one part cement to three parts sand, and the amount of mixing water shall be as little as consistent with the requirements of handling and placing. Color of cement grout shall match the adjacent wall surface. The surface shall be thoroughly cleaned of all stains or discolorations that will interfere with the final finish.
  - 2. Type II - Smooth Form Finish: Concrete shall be cast against forms constructed of plywood not less than 5/8 inch thick, or of boards lined with tempered hardboard not less than 3/16 inch thick, or other approved

materials. Form material shall not have torn grain, worn edges, patches of holes from previous use, or other defects which would impair the texture of the concrete surface. Form material shall utilize sheets as large as practicable in an orderly and symmetric configuration. Other aspects of the finish shall conform to the requirements of the rough form finish.

3. Type III - Grout Cleaned: Where this finish is required, it shall be applied after completion of Type II finish. After the concrete has been predampened, a slurry consisting of one part cement (including an appropriate quantity of white cement in order to produce a color matching the surrounding concrete) and 1-1/2 parts sand passing the No. 30 sieve, by damp loose volume, shall be spread over the surface with clean burlap pads or sponge rubber floats and scrubbed into the surface using a rotary motion. Any surplus material shall be removed by scraping and then rubbing with clean burlap. The finish shall be kept damp for at least 36 hours after application.
4. Type IV - Smooth Rubbed: Where this finish is required, it shall be applied after the completion of the Type II finish no later than one day following form removal. Nor rubbing shall be done before the concrete is thoroughly hardened and the mortar used for patching is firmly set. A smooth, uniform surface shall be obtained by wetting the surface and rubbing it with a carborundum stone to eliminate irregularities. Unless the nature of the irregularities requires it, the general surface of the concrete shall not be cut into. Corners and edges shall be slightly rounded by the use of the carborundum stone. Brush finishing or painting with grout or neat cement will not be permitted.
5. Type V - Textured: Use textured forms or textured form liners of plastic, wood, or sheet metal. Secure liner panels in forms by cementing or stapling, not by methods which will permit impressions of nail heads, screw heads, washers, or the like to be imparted to the surface of the concrete. Seal edges of textured panels to each other or to divider strips to prevent bleeding of cement paste. Use a sealant that will not stain the concrete surface.
6. Type VI - Aggregate transfer: Produce aggregate transfer and other special finished that duplicate mock-ups or sample panels prepared in advance and accepted.
7. Type VII - Exposed Aggregate: Expose aggregate using one of the following methods. Provide a concrete surface that will duplicate a mock-up or a sample panel prepared in advance and accepted.
  - a. For a scrubbed finish, cast concrete against form faces which have been coated with a chemical retarder used in accordance

with the manufacturer's recommendations. Wet the partially hardened concrete surface thoroughly and scrub with fiber or wire brushes, using water freely until the surface mortar is removed and the aggregate is uniformly exposed. Then rinse the surface with clear water. If portions of the surface have become too hard to permit uniform aggregate exposure, use dilute hydrochloric acid (one part commercial muriatic acid diluted with 4 to 10 parts water) to remove the excess surface mortar after the concrete is at least 2 weeks old. Remove the acid from the finished surface with clean water within 15 minutes after application.

- b. For a blast finish, sandblast or waterblast the concrete surface to a degree sufficient to expose fine aggregates with occasional exposure of coarse aggregate, and to produce a uniform color with a maximum reveal of 1/16 inch unless specified otherwise in the Contract Documents. All surfaces with the same specified blast finish shall be done at approximately the same time after placing concrete. Use stainless steel or plastic reinforcement supports and spacers near concrete surfaces to be blasted. Protect adjacent materials and inserts during blasting operations.
  - c. For a tooled finish, dress the thoroughly cured concrete surface with electric, air, or hand tools to a uniform texture removing surface mortar as specified in the Contract Documents. Then provide the surface with a hand tooled, rough or fine pointed, crandalled, or bush-hammered surface texture, as specified by Contract Documents.
8. Type VIII - Applied: When finishes of stucco, cementitious coatings, or similar troweled materials are required or permitted, prepare the surface of the concrete to ensure permanent adhesion of the finish. If the concrete is less than 24 hours old, roughen it with a heavy wire brush or scoring too. If the concrete is older, roughen the surface mechanically or by acid etching. After roughening, wash the surface free of all dust, acid, chemical retarder, and other foreign material before any final finish is applied.

### 3.02 SLAB AND FLOOR FINISHES

- A. The finishes described below shall be applied to floors, slabs, flow channels and top of walls in accordance with Article 3.05 - Concrete Finish Schedule. The Engineer shall be the sole judge of acceptability of all such finish work.
  - 1. Type "A" - Screeded: This finish shall be obtained by placing screeds at frequent intervals and striking off to the surface elevation required.

2. Type “B” - Scratched: Following completion of Type “A” finish, roughen the surface with stiff brushes or rakes before final set.
3. Type “C” - Floated: Following completion of Type “A” finish, do not work the concrete further until it is ready for floating. Begin floating with a hand float, a bladed power float equipped with float shoes, or a powered disc float as soon as the water sheen had disappeared and the surface has stiffened sufficiently to permit the operation. During or after the first floating, check flatness of surface with a 10 ft straightedge applied in two or more directions. Eliminate high spots and low spots during this procedure to produce a conventional, straight edge finish, then refloat the slab immediately to a uniform texture.
4. Type “D” - Troweled: Following completion of a Type “C” finish and sufficient hardening of the concrete to prevent excess fine material from working to the surface, the surface shall be compacted and smoothed with a power trowel. Following the power trowel, hand trowel to provide a smooth, dense surface, free from defects, trowel marks, and blemishes. For surfaces exposed to wear as indicated in the Contract Documents, continue hand troweling until a ringing sound is produced as the floor is troweled.
5. Type “E” - Broom or Belt: This finish shall provide the surface with a transverse scored texture by drawing a broom or burlap belt across the surface immediately after completion of a Type “C” finish.
6. Type “F” - Liquid Hardened Finish: Liquid hardened finish shall be provided by application of a liquid floor hardener. Floors to receive this finish shall have previously received a Type “D” finish. Liquid hardener shall be applied between 30 to 60 days after concrete placement. Surface to be treated shall be dry, clean and free of all loose dust, dirt, oil, wax, sealers and curing compounds. Application procedure shall be in accordance with manufacturer's instructions and shall consist of a three-coat treatment.
7. Type “G” - Dry Shake Hardened Finish: Aggregate hardened finish shall be provided by applying an aggregate floor hardener concurrently with the application of a Type “D” finish. Application procedure shall be in accordance with manufacturer's instructions.
8. Type “H” - Non-Slip Finish: This finish shall be provided by applying a non-slip shake-on aggregate concurrently with the application of a Type “D” finish. Application procedure shall be in accordance with manufacturer's instructions.

**GENERAL SPECIFICATION 03350 - CONCRETE FINISHES**

---

3.03 SEALING OF CONCRETE FLOOR

- A. After installation of all equipment and piping, and after completion of other related construction activities, all floor slabs which are to remain unpainted and not intended to be immersed, and all equipment pads, shall be sealed with a floor sealer unless the slab has had liquid hardener applied or stated otherwise. Remove all dirt, droppage, grease, asphalt or other foreign matter with caustics and detergents as required prior to application. Sealer shall be applied in accordance with the manufacturer's recommendations.

3.04 FINISHES ON EQUIPMENT PADS

- A. Formed surfaces of equipment pads shall receive a Type II finish.
- B. Top surfaces of equipment pads, except those surfaces subsequently required to receive non-shrink grout and support equipment bases, shall receive a Type "D" finish, unless otherwise noted. Surfaces which will later receive non-shrink grout shall, before the concrete takes its final set, be made rough by removing the sand and cement that accumulates on the top to the extent that the aggregate will be exposed with irregular indentations in the surface up to 1/2 inch deep.

3.05 CONCRETE FINISH SCHEDULE

<b>Item</b>	<b>Finish Type</b>
All concrete surfaces not exposed to public view including utility spaces	I
All exterior surfaces and interior vertical surfaces exposed to public view	IV
All interior overhead surfaces exposed to public view and interior walls of tanks	II
Surfaces to be painted	III
Architectural finish	V, VI, VII, or VIII as indicated in the contract documents
Surfaces to receive bonded cementitious mixtures	B
Drives, interior stairs, surfaces to receive waterproofing, roofing insulation, or terazzo, and floors of tanks	C
Floors for walking surfaces in manufacturing, storage, and warehousing areas, and floors to receive coverings	D



**GENERAL SPECIFICATION 03350 - CONCRETE FINISHES**

---

<b>Item</b>	<b>Finish Type</b>
Sidewalks	E
Garage and storage area floors	F or G
Exterior stairs, platforms, landings and ramps and interior ramps	E or H

END OF SECTION

NO TEXT ON THIS PAGE

**SECTION 03600  
Grout**

**PART 1 GENERAL**

**1.01 SECTION INCLUDES**

- A. The Contractor shall furnish all materials, labor, and equipment required to provide all grout used in concrete work and as bearing surfaces for base plates as indicated on the Contract Drawings, in accordance with the requirements of the Detailed Specifications and as specified herein.
- B. The following index of this Section is included for convenience:

<u>Article</u>	<u>Title</u>	<u>Page</u>
		03600-
PART 1	GENERAL .....	1
1.01	Section Includes .....	1
1.02	Related Sections .....	1
1.03	Payment .....	1
1.04	References .....	2
1.05	Submittals .....	2
1.06	Quality Assurance .....	2
1.07	Services Of Manufacturer's Representative .....	3
PART 2	PRODUCTS .....	4
2.01	Cement Grout .....	4
2.02	Non-Shrink Grout .....	5
2.03	Epoxy Grout .....	6
2.04	Dry Pack .....	6
2.05	Curing Materials .....	6
PART 3	EXECUTION .....	6
3.01	Grout Uses .....	6
3.02	Installation .....	7

**1.02 PAYMENT**

- A. Unless otherwise provided in the Detailed Specifications, no separate payment will be made for any Work required under this Section and the Contractor shall include all costs thereof in its lump sum price bid for the Contract.

**1.03 RELATED SECTIONS**

- A. General Specification 03300 - Cast-in-Place Concrete.

## GENERAL SPECIFICATION 03600 - GROUT

---

### 1.04 REFERENCES

- A. ASTM C109 - Test Method for Compressive Strength of Hydraulic Cement Mortars (Using 2 inch or 50 mm Cube Specimens).
- B. ASTM C531 - Test Method for Linear Shrinkage and Coefficient of Thermal Expansion of Chemical-Resistant Mortars, Grouts and Monolithic Surfacing.
- C. ASTM C579 - Test Method for Compressive Strength of Chemical-Resistant Mortars and Monolithic Surfacing.
- D. ASTM C939 - Test Method for Flow of Grout for Preplaced-Aggregate Concrete (Flow Cone Method).
- E. ASTM C1107 - Packaged Dry, Hydraulic Cement Grout (Nonshrink).
- F. CRD-C 621 - Corps of Engineers Specification for Non-shrink Grout.

### 1.05 SUBMITTALS

- A. The Contractor shall submit Shop Drawings and material specifications for the approval of the Engineer. Shop drawings shall include, but not be limited to:
  - 1. Material certifications and technical data sheets.
  - 2. Samples of all materials to be used.
- B. The Contractor shall also submit the following:
  - 1. Certified test results verifying the compressive strength, shrinkage and expansion requirements specified herein.
  - 2. Manufacturer's literature containing instructions and recommendations on the mixing, handling, placement and appropriate uses for each type of grout used in the work.

### 1.06 QUALITY ASSURANCE

- A. Field Tests:
  - 1. Compression test specimens will be taken during construction from the first placement of each type of grout and at intervals thereafter as selected by the Engineer to insure continued compliance with these Specifications.
    - a. Compression tests and fabrication of specimens for cement grout and non-shrink grout will be performed as specified in ASTM C109 at intervals during construction as selected by the Engineer. A set of three specimens will be made for testing at

## GENERAL SPECIFICATION 03600 - GROUT

---

seven days, 28 days and any additional time period as appropriate.

- b. Compression tests and fabrication of specimens for epoxy grout will be performed as specified in ASTM C579, Method B, at intervals during construction as selected by the Engineer. A set of three specimens will be made for testing at seven days and any other time period as appropriate.

### B. Testing Agency:

1. Testing of materials and of resulting grout for compliance with the technical requirements of the specification shall be the duty of the testing agency designated in the Detailed Specifications.
  - a. The testing agency shall be responsible to and report directly to the Supervising Engineer for Concrete Construction.
  - b. Payment for services rendered by the testing agency shall be as designated in the Detailed Specifications.
  - c. The Contractor shall be charged for the cost of any additional tests and investigation on work performed which does not meet the specifications.

- C. All grout which has already been placed and which fails to meet the requirements of these Specifications, is subject to removal and replacement by the Contractor at no additional cost to the City.

### 1.07 SERVICES OF MANUFACTURER'S REPRESENTATIVE

- A. The Contractor shall provide the services of a qualified manufacturer's technical representative who shall instruct the Contractor's personnel in the mixing, proper use and application of the non-shrink grout and epoxy grout.
- B. The manufacturer's representative shall provide written certification that materials have been mixed and applied properly and surfaces to receive these products have been prepared properly, all in conformance with manufacturer's requirements.
- C. The on-site time required for the manufacturer's representative to achieve a successful installation shall be at the expense of the Contractor. The manufacturer's representative shall sign in and out at the office of the Resident Engineer and provide written verification of the areas he has approved on each day he is at the project.

**GENERAL SPECIFICATION 03600 - GROUT**

---

**PART 2 PRODUCTS**

**2.01 CEMENT GROUT**

- A. Cement grout shall be composed of Portland cement, sand and water. The sand to be used shall be selected to suit the spacing for placement. Where sand is not usable, the grout shall be composed of cement and water only.
- B. Gradation of sand and mix proportioning shall be in accordance with the following table for grouts using natural sands and having a minimum 28-day compressive strength of 4,000 psi. For higher strength grouts or those using manufactured sands, strength shall be established by trial mixes.

1. Gradation for Natural Sand:

<b>Sieve Size</b>	<b>Spaces less than one (1) inch</b>	<b>Spaces one (1) inch or more</b>
Passing 3/8		100
Passing 4	100	95-100
Passing 8	95-100	80-100
Passing 16	70-100	50-85
Passing 30	40-75	25-60
Passing 50	10-35	10-30
Passing 100	2-15	2-10
Passing 200	--	--

2. Mix Proportioning:

<b>By Weight</b>	<b>Non-Air Entrained Grouts (Maximum 4 Percent Entrapped Air)</b>		<b>Air Entrained Grouts (Air 8 Percent to 10 Percent)</b>	
	<b>Spaces less than one (1) inch</b>	<b>Spaces one (1) inch or more</b>	<b>Spaces less than one (1) inch</b>	<b>Spaces one (1) inch or more</b>
Cement (bags)	10.8	10.5	11.3	11.0
Sand (lb)	2150	2240	1930	1990
Maximum water (gals)	59.5	57.8	57.5	55.8

**GENERAL SPECIFICATION 03600 - GROUT**

---

<b>By Weight</b>	<b>Non-Air Entrained Grouts (Maximum 4 Percent Entrapped Air)</b>		<b>Air Entrained Grouts (Air 8 Percent to 10 Percent)</b>	
	<b>Spaces less than one (1) inch</b>	<b>Spaces one (1) inch or more</b>	<b>Spaces less than one (1) inch</b>	<b>Spaces one (1) inch or more</b>
Maximum water (gals per bag)	5.5	5.5	5.1	5.1

<b>By Volume</b>	<b>Non-Air Entrained Grouts (Maximum 4 Percent Entrapped Air)</b>		<b>Air Entrained Grouts (Air 8 Percent to 10 Percent)</b>	
	<b>Spaces less than one (1) inch</b>	<b>Spaces one (1) inch or more</b>	<b>Spaces less than one (1) inch</b>	<b>Spaces one (1) inch or more</b>
Cement	1	1	1	1
Sand (dry rodded)	1.85	2.10	1.6	1.7
Sand (damp & loose)	2.30	2.35	2.0	2.1
Maximum water (gals per bag)	5.5	5.5	5.1	5.1

- C. Water shall be kept to a minimum, the amounts noted in the preceding table are the maximum for grout. Proportioning by volume shall be limited to small quantities mixed at the job site.
  - D. White Portland cement shall be mixed with the Portland cement as required to match the color of adjacent concrete.
- 2.02 NON-SHRINK GROUT
- A. The grout material shall be an approved ready to use mixture requiring only water for use at the job site. The compressive strength of 2-inch cubes shall be 3,000 psi at 7 days.
  - B. Non-shrink grout shall conform to CRD-C 621 and ASTM C1107, Grade B or C when tested at a maximum fluid consistency of 30 seconds per ASTM C939 at temperature extremes of 45 degrees Fahrenheit and 90 degrees Fahrenheit and an extended working time of 15 minutes.

- C. Non-shrink grout shall be:
  - 1. Euco N-S as manufactured by Euclid Chemical Company, East Brunswick, NJ.
  - 2. Masterflow 713 as manufactured by Master Builders Solutions, Shakopee, MN.
  - 3. Sikagrout 212 as manufactured by Sika Corporation, Lyndhurst, NJ.
  - 4. Or approved equal.
- D. Non-shrink grouts depending on oxidation to limit shrinkage and containing additives such as iron or steel particles shall not be used.

### 2.03 EPOXY GROUT

- A. Epoxy grout shall be modified as required for each particular application with aggregate per manufacturer's instructions.
- B. Epoxy grout shall be:
  - 1. Sikadur 32 Hi-Mod as manufactured by Sika Corporation, Lyndhurst, NJ.
  - 2. Euco #452 as manufactured by Euclid Chemical, East Brunswick, NJ.
  - 3. Duralcrete LV as manufactured by Tamms Industries, Kirkland, IL.
  - 4. Or approved equal.

### 2.04 DRY PACK

- A. Dry pack (to be packed or tamped in place) shall be made at no slump consistency.
- B. When mixing the batch, only enough water shall be added to the dry materials to produce a rather stiff mixture, then additions of water may be made in small increments until the desired consistency is obtained.

### 2.05 CURING MATERIALS

- A. Curing materials for cement grout shall be as specified in General Specification 03300 – Cast-in-Place Concrete and as recommended by the manufacturer for prepackaged grouts.

## PART 3 EXECUTION

### 3.01 GROUT USES

- A. The different types of grout shall be used for the applications stated below unless noted otherwise in the Detailed Specifications or on the Contract Drawings. Where grout is called for in the Detailed Specifications or on the



## GENERAL SPECIFICATION 03600 - GROUT

---

Contract Drawings which does not fall under any of the applications stated below, non-shrink grout shall be used.

1. Cement grout shall be used for grout toppings and for patching of fresh concrete.
  2. Non-shrink grout shall be used for grouting beneath base plates of equipment and structural metal framing.
  3. Epoxy grout shall be used for bonding new concrete to hardened concrete.
- B. New concrete surfaces to receive cement grout shall be as specified in General Specification 03300 – Cast-in-Place Concrete, and shall be cleaned of all dirt, grease and oil-like films.
1. Existing concrete surfaces shall likewise be cleaned of all similar contamination and debris, 4 protection of cement grout shall be as specified in General Specification 03300 – Cast-in-Place Concrete.
  2. Curing and protection of cement grout shall be as specified in General Specification 03300 – Cast-in-Place Concrete.
- C. All mixing, surface preparation, handling, placing, consolidation, and other means of execution for prepackaged grouts shall be done according to the instructions and recommendations of the manufacturer.

### 3.02 INSTALLATION

- A. The consistency of grouts shall be that necessary to completely fill the space to be grouted for the particular application. Dry pack consistency shall be such that the grout is plastic and moldable but will not flow.
- B. Measurements for cement grout shall be made accurately by weight or by volume using containers. All measurements shall be made in a manner satisfactory to the Engineer. Prepackaged grouts shall have ingredients measured by means recommended by the manufacturer.
- C. Grout shall be placed quickly and continuously, shall completely fill the space to be grouted, be thoroughly compacted and free of air pockets. The grout may be poured in place, pressure grouted by gravity, or pumped.
- D. For grouting beneath base plates, grout shall be poured from one side only and shall flow across to the open side to avoid air-entrapment.
- E. The use of pneumatic pressure or dry-packed grouting requires approval of the Engineer.

END OF SECTION

**GENERAL SPECIFICATION 03600 - GROUT**

---

NO TEXT ON THIS PAGE

**SECTION 04051  
Mortar and Masonry Grout**

**PART 1 GENERAL**

**1.01 SUMMARY**

- A. Mortar and masonry grout as specified herein include, but are not limited to, Portland Cement, lime, sand, coarse aggregate, admixtures for use in mortar and masonry grout, and appurtenances.
- B. Mortar and masonry grout shall be provided as indicated on the Contract Drawings, specified herein or in the Detailed Specifications, or as required for a complete installation.
- C. The Contractor shall implement practices and procedures to meet the project’s sustainability goals as identified in the Contract Documents. The Contractor shall ensure that the sustainability requirements of this Section are implemented to the fullest extent.
- D. The following index of this Section is included for convenience:

<u>Article</u>	<u>Title</u>	<u>Page</u>
		04051-
PART 1	GENERAL.....	1
1.01	Summary.....	1
1.02	Payment.....	2
1.03	Related Sections.....	2
1.04	References.....	2
1.05	System Design Requirements.....	2
1.06	Quality Assurance.....	3
1.07	Submittals.....	3
1.08	Delivery, Storage, And Handling.....	4
PART 2	PRODUCTS.....	5
2.01	Manufacturers.....	5
2.02	Materials.....	5
2.03	Mixes.....	6
2.04	Mixing.....	7
PART 3	EXECUTION.....	8
3.01	Preparation.....	8
3.02	Installation.....	8
3.03	Field Quality Control.....	8

## **GENERAL SPECIFICATION 04051 - MORTAR AND MASONRY GROUT**

---

### 1.02 PAYMENT

- A. No separate payment will be made for performing any work of this section; the Contractor shall include all costs thereof in the lump sum price bid for the Contract, except as provided for in the Detailed Specifications.

### 1.03 RELATED SECTIONS

- A. General Specification 04200 - Unit Masonry

### 1.04 REFERENCES

- A. ASTM C91 - Standard Specifications for Masonry Cement
- B. ASTM C144 - Standard Specification for Aggregate for Masonry Mortar
- C. ASTM C150 - Standard Specification for Portland Cement
- D. ASTM C207 - Standard Specification for Hydrated Lime for Masonry Purposes
- E. ASTM C270 - Standard Specification for Mortar for Unit Masonry
- F. ASTM C404 - Standard Specification for Aggregates for Masonry Grout
- G. ASTM C476 - Standard Specification for Grout for Masonry
- H. ASTM C595 - Standard Specification for Blended Hydraulic Cement
- I. ASTM C780 - Standard Test Method for Preconstruction and Construction Evaluation of Mortars for Plain and Reinforced Unit Masonry
- J. ASTM C1329 - Standard Specification for Motor Cement
- K. ASTM C1019 - Standard Test Method for Sampling and Testing Grout
- L. NYCBC - Section BC 2103 Masonry Construction Materials, BC 2104 Construction

### 1.05 SYSTEM DESIGN REQUIREMENTS

- A. Where questions of compliance with the requirements of this Section arise, the specifications for mortar properties shall take precedence over the specification for mortar proportions.
- B. No change shall be made in the proportions established for mortar approved under the specifications for mortar properties nor shall material with different

physical characteristics be utilized in mortar used in the work unless compliance with the specifications for mortar properties are re-established by Shop Drawing data submission to Engineer.

- C. Two different air-entraining materials shall not be combined in mortar or grout.
- D. Sustainable Design Requirements:
  - 1. Recycled Content of Mortar and Masonry Grout Products: Postconsumer recycled content plus one-half of preconsumer recycled content not less than 15 percent.
- E. Project-specific system/ design requirements will be provided in the Detailed Specifications, if necessary, to supplement requirements given herein or Contract Drawings.

#### 1.06 QUALITY ASSURANCE

- A. Source Limitations for Masonry Units: Obtain exposed masonry units of a uniform texture and color, or a uniform blend within the ranges accepted for these characteristics, from single source from single manufacturer for each product required.
- B. Source Limitations for Mortar Materials: Obtain mortar ingredients of a uniform quality, including color for exposed masonry, from single manufacturer for each cementitious component and from single source or producer for each aggregate.
- C. The Contractor shall engage an independent testing agency to conduct tests specified herein and as follows:
  - 1. Mortar: Mortar tests shall be performed in accordance with ASTM C270.
  - 2. Grout: Grout tests shall be performed in accordance with ASTM C1019.
- D. Requirements of Regulatory Agencies: Wherever a fire-resistance classification is shown or scheduled for unit masonry construction (4-hour, 3-hour and similar designations), proportion mortar and masonry grouts to comply with the requirements established by UL and other governing authorities having jurisdiction at the Project Site.

#### 1.07 SUBMITTALS

- A. The Contractor shall submit the Shop Drawings for the approval of the Engineer. Submittals shall include, but not be limited to:
  - 1. Product Data: Manufacturer's specifications and installation instructions for proprietary materials.

## **GENERAL SPECIFICATION 04051 - MORTAR AND MASONRY GROUT**

---

2. Certificates: Notarized certificates that the following comply with the specified requirements:
    - a. Portland Cement
    - b. Hydrated lime
    - c. Mortar and grout aggregates
  3. Design Mix: Certified design mix for mortar and grout.
  4. Test Results: Results of mortar and grout tests as specified herein and as specified in referenced standards.
  5. Samples:
    - a. Each type of colored mortar in metal channels at least 6-inches long, showing the range of color that can be expected in the finished work.
    - b. Complete selection of standard and custom colors of epoxy grout used for pointing mortar, for final selection by Engineer.
    - c. Label samples to indicate type and amount of colorant used. Engineer's review will be for color only. Compliance with all other requirements is the responsibility of Contractor.
  6. Construction: Weight slips for grout materials at time of delivery.
  7. Schedule of locations where each mortar and grout type will be used in the work.
- B. Sustainable Design Submittals:
1. Environmental Materials Reporting Form (EMRF) Recycled Content. Provide the following information:
    - a. Name of Product and Manufacturer.
    - b. Material cost breakdowns. Cost breakdowns must include total material-only cost (excluding installation, labor and equipment).
    - c. The percentage (by weight) of post-consumer and pre-consumer recycled content.

### 1.08 DELIVERY, STORAGE, AND HANDLING

- A. Delivery of Materials:
1. Materials shall not be delivered to the Site before the time of installation.
  2. Materials delivered and stored at the Site shall be from approved manufacturers and sources only.
  3. Materials shall be delivered in sufficient quantities to allow continuity of the work.

B. Storage of Materials:

1. Materials shall be stored in original, undamaged containers with manufacturer's labels and seals intact.
2. Cement shall be stored in weathertight containers that exclude moisture and contaminants.
3. Hydrated lime shall be stored in weathertight containers that exclude moisture and contaminants.
4. Aggregates shall be kept clean and free from other materials during transportation and handling. Aggregate shall be stockpiled in a manner to prevent segregation.
5. Damage to materials during storage shall be prevented primarily by minimizing the amount of time they are stored at the Site before being incorporated into construction systems.

C. Handling of Materials:

1. Materials shall be handled in such a manner to avoid damage or breakage.
2. Materials shall not be exposed to detrimental conditions or physical damage. Materials which are so exposed shall be removed from the Site and shall not be incorporated into the work.
3. Materials shall be handled in such a manner to prevent inclusion of contaminants.
4. Packages or containers shall not be opened until all preparatory work is complete and installation is to begin immediately. Materials shall not be allowed to become wet or soiled or covered with ice or snow.

PART 2 PRODUCTS

2.01 MANUFACTURERS

- A. Manufacturers of mortar and masonry grout items shall be as specified in the Detailed Specifications.

2.02 MATERIALS

A. Portland Cement:

1. Provide Type I or III Portland Cement that conforms to the requirements of ASTM C150.
2. Provide nonstaining Portland Cement of natural color or of the color required to be compatible with the required colored mortar pigment selected by Engineer.

## **GENERAL SPECIFICATION 04051 - MORTAR AND MASONRY GROUT**

---

- B. Hydrated Lime: Provide Type S hydrated lime that conforms to the requirements of ASTM C207.
  - C. Sand for Mortar: Provide natural sand that conforms to the requirements of the following:
    - 1. ASTM C144, except for joints less than 1/4 inch use aggregate graded with 100 percent passing the No. 16 sieve.
    - 2. White Mortar Aggregates: Provide natural white sand or ground white stone for Portland cement-lime mortars, as required for compatibility with mortar colors selected by Engineer.
    - 3. Colored Mortar Aggregates: Provide ground marble, granite or other sound stone, as required to match the sample approved by Engineer for Portland Cement-lime mortars.
  - D. Aggregates for Grout: Provide fine and coarse aggregates that conform to the requirements of ASTM C404, ASTM C476.
  - E. Coloring Additive: A mineral-oxide pigment, harmless to mortar set and strength shall be provided. Colors shall be as selected by the Engineer.
  - F. Epoxy Pointing Mortar:
    - 1. Provide a two-component non-sag epoxy resin and hardener with mineral filler complying with ANSI A118.3.
    - 2. Colors: Complete selection of standard and custom colors for final selection by Engineer.
    - 3. Provide epoxy mortar capable of water-cleanup during installation but which, after curing, is waterproof.
  - G. Water: Provide clean and potable water from approved sources.
- 2.03 MIXES
- A. Mortar: Provide mortar that conforms to the requirements of ASTM C270, except as modified herein, and of the type and color specified in the Detailed Specifications.
    - 1. Provide a cement-lime mortar; masonry cement mortars are not acceptable.
    - 2. Calcium chlorides are not permitted.
    - 3. Admixtures shall not be used unless specifically directed by the Detailed Specifications.
  - B. Grout: Provide grout that conforms to the requirements of ASTM C476, ASTM C404 for fine or coarse grout.



## **GENERAL SPECIFICATION 04051 – MORTAR AND MASONRY GROUT**

---

1. Fine grout shall be used for filling spaces with openings less than 2 inches.
2. Course grout shall be used for filling spaces with openings greater than 2 inches.

### 2.04 MIXING

#### A. Measurement of Materials:

1. Cement and Hydrated Lime: Batched by the bag.
2. Sand: Batched by volume in suitably calibrated containers. Make allowance for bulking and consolidation, and for weight per cubic foot of contained moisture.
3. Proportion of Volumetric Mixtures: One 94-pound sack of Portland cement and one 50-pound sack of hydrated lime constitute nominal one cubic foot.
4. Shovel measurement: Not permitted.

#### B. Mortar:

1. All cementitious materials and aggregates shall be mixed between three and five minutes in a mechanical batch mixer with a sufficient amount of water to produce a workable consistency. Mortar shall not be hand mixed.
2. When required, cement and pigment shall be mixed for colored mortar prior to mixing in mortar. The maximum percentage by weight of cement for pigment shall be limited to 10 percent.
3. Limit batch size to avoid retempering.
4. Mortar that has begun to stiffen or is not used within two hours after initial mixing shall not be used.
5. The mixer drum shall be completely emptied before recharging the next batch.

#### C. Mortar Temperature:

1. For temperatures below 40 degrees F mortar materials shall be heated to protect both mortar and completed work from freezing.
2. When outside air temperature is:
  - a. 25 to 40 degrees F: Mixing water and sand shall be heated to produce mortar temperature between 40 and 120 degrees F. Temperatures of mortar on boards shall be maintained above freezing.
  - b. Below 25 degrees F: Masonry shall not be installed.

## **GENERAL SPECIFICATION 04051 - MORTAR AND MASONRY GROUT**

---

3. Ideal mortar temperature is 70 degrees F  $\pm$ 10 degrees F. Mixing temperature selected shall be maintained within 10 degrees F.
  4. Antifreeze compounds or calcium chloride in mortars shall not be used to lower the freezing point or accelerate setting.
- D. Grout: Grout shall be mixed in accordance with the requirements of ASTM C476.
- E. Epoxy Pointing Mortar: Epoxy pointing mortar shall be mixed in strict accordance with the manufacturer's instructions.

### **PART 3 EXECUTION**

#### **3.01 PREPARATION**

- A. Prior to placing mortar or grout, remove laitance, loose aggregate and any substance that may prevent mortar or grout from bonding to the foundation.

#### **3.02 INSTALLATION**

- A. Installation of mortar and grout shall be in accordance with the requirements of General Specification 04200 – Unit Masonry
- B. Installation of epoxy grout shall be in accordance with the manufacturer's instructions and recommendations.

#### **3.03 FIELD QUALITY CONTROL**

- A. Mortar shall be prepared and tested for preconstruction and construction evaluation in accordance with the requirements of ASTM C780. Specimens for construction evaluation shall be prepared a minimum of every 500 square feet of masonry construction.
- B. Grout shall be prepared and tested for construction evaluation in accordance with the requirements specified in ASTM C1019 and NYCBC Section BC 2104. Specimens shall be prepared a minimum of every 100 cubic feet of grout placed.

END OF SECTION

**SECTION 04400  
Stone Masonry Units**

**PART 1 GENERAL**

**1.01 SUMMARY**

- A. Stone masonry units as specified herein include, but are not limited to, limestone, coursed ashlar stone, rough ashlar stone, reinforcement, anchorage, and all accessories and appurtenances.
- B. Stone masonry unit items shall be provided where shown on the Contract Drawings, specified in the Detailed Specifications, or as required for a complete installation.
- C. The Contractor shall implement practices and procedures to meet the project’s sustainability goals as identified in the Contract Documents. The Contractor shall ensure that the sustainability requirements of this Section are implemented to the fullest extent.
- D. The following index of this Section is included for convenience:

<u>Article</u>	<u>Title</u>	<u>Page</u>
		04400-
PART 1	GENERAL.....	1
1.01	Summary.....	1
1.02	Payment.....	2
1.03	Related Sections.....	2
1.04	References.....	2
1.05	System Design Requirements.....	2
1.06	Quality Assurance.....	2
1.07	Submittals.....	3
1.08	Delivery, Storage, And Handling.....	3
PART 2	PRODUCTS.....	4
2.01	Manufacturers.....	4
2.02	Materials.....	4
PART 3	EXECUTION.....	5
3.01	Installation.....	5
3.02	Cleaning.....	6
3.03	Protection.....	6
3.04	Adjustment.....	7

## GENERAL SPECIFICATION 04400 – STONE MASONRY UNITS

---

### 1.02 PAYMENT

- A. No separate payment will be made for performing any work of this Section; the Contractor shall include all costs thereof in the lump sum prices bid for the Contract, except as provided for in the Detailed Specifications.

### 1.03 RELATED SECTIONS

- A. General Specification 04051 - Mortar and Masonry Grout
- B. General Specification 07900 - Caulking and Sealants

### 1.04 REFERENCES

- A. ASTM A276 - Standard Specification for Stainless Steel Bars and Shapes
- B. ASTM C97 - Standard Test Methods for Absorption and Bulk Specific Gravity of Dimension Stones
- C. ASTM C99 - Standard Test Method for Modulus of Rupture of Dimension Stone
- D. ASTM C170 - Standard Test Method for Compressive Strength of Dimension Stone
- E. ASTM C568 - Standard Specification for Limestone Dimension Stone
- F. Indiana Limestone Institute of America, Incorporated (ILI)
  - 1. ILI - Contractor's Handbook on Indiana Limestone
  - 2. ILI - Technote on Safety Factors

### 1.05 SYSTEM DESIGN REQUIREMENTS

- A. Project-specific system description or design requirements for the work of this Section will be provided in the Detailed Specifications, if necessary, to supplement the requirements given herein or in the Contract Drawings.

### 1.06 QUALITY ASSURANCE

- A. Specifications: Stone masonry unit materials and installation shall conform to the requirements of ASTM C568.
- B. Sample Panel: The Contractor shall erect a composite 4 feet long by 3 feet high sample panel.
  - 1. The sample panel shall include elements typical of the stonework on this project.
  - 2. Upon approval, the sample panel shall remain in place for the duration of stone masonry unit construction and shall be used as a basis of comparison for all stone masonry unit work.

3. After final approval of finished stone masonry unit work by the Engineer, the Contractor shall demolish the sample panel, and shall perform all site restoration work.

1.07 SUBMITTALS

- A. The Contractor shall prepare and submit Shop Drawings and reference materials for approval of the Engineer. Submittals shall include, but not be limited to the following:
  1. Samples: The Contractor shall submit three 12-inch square samples of stone that are representative of the full range of color, grain, and texture of the material to be provided.
  2. Shop Drawings: The Contractor shall submit cutting and setting drawings indicating sizes, dimensions, sections and profiles of stones, along with arrangement and provisions for jointing, supporting, anchoring, and bonding stonework. Shop Drawings shall include relationship with, attachment to, and reception of all related Work.
  3. Test Reports: The Contractor shall submit material test reports of tests performed on stone masonry units in accordance with ASTM C99 for Modulus of Rupture and ASTM C170 for Compressive Strength.

1.08 DELIVERY, STORAGE, AND HANDLING

- A. Delivery of Materials:
  1. Materials shall not be delivered to the project site before the time of installation.
  2. Stone masonry unit materials delivered and stored at the site shall be from approved manufacturers and sources only.
  3. Materials shall be delivered in sufficient quantities to allow continuity of the Work.
- B. Storage of Materials:
  1. Materials shall be stored in original, undamaged containers with manufacturer's labels and seals intact.
  2. All stone masonry units shall be stored on non-staining wood skids or pallets under shelter, or covered with non-staining waterproof membrane so as to protect these materials from soil and weather.
  3. Damage to materials during storage shall be prevented primarily by minimizing the amount of time they are stored at the project site before being incorporated into construction systems.
- C. Handling of Materials:
  1. Materials shall be handled in such a way to avoid damage or breakage.

2. Stone masonry units shall be lifted using wide-belt slings. Pinch bars, wrecking bars, wire ropes, or ropes containing tar or other substances which might cause staining or damage shall not be used.
  3. Materials shall not be exposed to detrimental conditions or physical damage. Materials which are so exposed shall be permanently removed from the project site and shall not be incorporated into the Work.
  4. Materials shall be handled in such a manner so as to prevent inclusion of foreign materials.
  5. Packages or containers shall not be opened until all necessary preparatory work is complete and installation is to begin immediately. Materials shall not be allowed to become wet or soiled or covered with ice or snow.
- D. Rejection: Stone masonry units that are warped, cracked or of inferior quality will be rejected. Such items shall be removed from the site and not offered again for inspection.

## PART 2 PRODUCTS

### 2.01 MANUFACTURERS

- A. Acceptable manufacturers of stone masonry unit items shall be as specified in the Detailed Specifications. Other manufacturers of equivalent products may be submitted.

### 2.02 MATERIALS

- A. Limestone: Limestone shall be Select Grade Indiana Oolitic limestone as quarried in Lawrence, Monroe or Owens Counties, Indiana. Limestone shall be from a single quarry producing a product that has been tested at the National Bureau of Standards for physical properties and weathering, and shall be free from all defects which would impair its strength, durability or appearance. Stone shall be cut accurately, true and square to shape and dimensions shown. All projecting members shall have a deep drip. Holes and sinkages shall be cut as required for all anchors, cramps, dowels and other accessories.
- B. Coursed Ashlar Stone: Coursed ashlar stone shall be coursed ashlar Indiana Limestone as quarried in Lawrence or Monroe Counties. Stone color and finish shall be as specified in the Detailed Specifications.
1. Bed thickness shall be between 3 inches and 4 inches as shown on the Contract Drawings.
  2. Course heights shall be 2-1/4-inch, 5-inch, 7-3/4-inch, 10-1/2-inch and 16-inch. Heights to be used, and percentages of each shall be as specified in the Detailed Specifications.

3. Stone lengths shall be random, varying between 1 foot 6 inches and 4 feet 0 inches, and shall be jointed at the job conforming to the approved jointing pattern.
- C. Rough Ashlar Stone: Rough ashlar stone shall be webwall or drywall Indiana Limestone as quarried in Lawrence or Monroe Counties with a rough, broken finish. Stone color shall be as specified in the Detailed Specifications.
1. Bed thickness shall be as shown on the Contract Drawings.
  2. Webwall exposed faces shall vary from 1/2 to 3 square feet.
  3. Drywall exposed stone edges shall vary between 2 inches and 6 inches in height.
- D. Metal Accessories: The Contractor shall provide Type 316 stainless steel for anchors, anchor slots, ties and reinforcement.
- E. Rigid Anchors: Rigid ASTM A276, Type 316, stainless steel anchors shall be 1-inch wide by 3/16-inch thick.
- F. Weep Holes: Weep holes shall be provided where shown, and shall consist of clear polyethylene, medium density plastic, rectangular tubes, 3/8 inch wide, 1-1/2 inches high, 3-1/2 inches deep.
- G. Anchors, Cramps and Dowels for Stone: All anchors, cramps and dowels for stone shall be of Type 316 stainless steel.
- H. Mortar Materials: Mortar materials shall be in accordance with General Specification 04051 - Mortar and Masonry Grout.

## PART 3 EXECUTION

### 3.01 INSTALLATION

- A. Limestone Setting: Limestone shall be set in nonstaining mortar, true to line and level, with each joint entirely filled with mortar unless otherwise indicated. Plastic buttons shall be used where necessary to prevent crushing of mortar under heavy blocks. Heavy stone or projecting courses shall not be set until the mortar in courses underneath have hardened. All projecting stone shall be securely braced until the wall above it is built and adequately cured.
- B. Limestone Joints: All joints shall be a uniform 3/8-inch in thickness. All face joints in stone masonry shall be raked out to a depth of 3/4 inch, brushed clean and caulked with sealant as specified in General Specification 07900 – Caulking and Sealants, unless otherwise indicated. Relief joints shall be provided in all stonework at intervals not to exceed 50 feet on centers. Copings and all projecting stone shall be set with wash surfaces, and with the vertical and top joints free of mortar. Face or profile of these joints shall be caulked over a backup material in accordance with General Specification 07900 – Caulking and Sealants. Prior to caulking, all joints shall be primed with a saturating coat

of caulking compound primer as recommended by the caulking compound manufacturer.

- C. **Coursed Ashlar Stone Setting:** Coursed ashlar stone shall be set in nonstaining mortar, true to level, with each joint entirely filled with mortar unless otherwise indicated. Plastic buttons shall be used where necessary to prevent crushing of mortar under heavy blocks. Heavy stone or projecting courses shall not be set until the mortar in courses underneath have hardened. All projecting stone shall be securely braced until the wall above it is built and adequately cured.
- D. **Coursed Ashlar Stone Joints:** All joints shall be a uniform 3/8-inch in thickness. Relief joints shall be provided in all stonework at intervals not to exceed 50 feet on centers. All projecting stone shall be set with wash surfaces, and with the vertical and top joints free of mortar. Face or profile of these joints shall be caulked over a backup material in accordance with the Detailed Specifications. Prior to caulking, all joints shall be primed with a saturating coat of caulking compound primer as recommended by the caulking compound manufacturer.
- E. **Rough Ashlar Stone Setting:** Rough ashlar stone, either webwall or drywall, shall be set in nonstaining mortar with each joint entirely filled with mortar unless otherwise indicated. Soft lead pads or plastic buttons shall be used where necessary to prevent crushing of mortar under heavy stones. Heavy stone or projecting courses shall not be set until the mortar in courses underneath has hardened. All projecting stone shall be securely braced until the wall above it is built and adequately cured.
- F. **Rough Ashlar Stone Joints:** All joints shall be a minimum 3/8-inch in thickness. Relief joints shall be provided in all stonework at intervals not to exceed 50 feet on centers. All projecting stone shall be set with wash surfaces, and with the vertical and top joints free of mortar. Face or profile of these joints shall be caulked over a backup material in accordance with the Detailed Specifications. Prior to caulking, all joints shall be primed with a saturating coat of caulking compound primer as recommended by the caulking compound manufacturer.

### 3.02 CLEANING

- A. **General:** After mortar has set, new stone masonry unit work shall be cleaned as follows:
  - 1. All excess mortar and mortar smears shall be removed. All defective mortar shall be removed and replaced, matching adjacent work. Nonmetallic tools shall be used in all cleaning operations.
  - 2. Stone masonry units shall be washed with clean water and soap powder using stiff bristle fiber brushes.

### 3.03 PROTECTION

- A. All components of the Work shall be protected from detrimental weather and damage until construction operations are completed and acceptable to Engineer.



## GENERAL SPECIFICATION 04400 – STONE MASONRY UNITS

---

Protective boards shall be provided at exposed external corners susceptible to damage by construction activities, without damaging completed work.

- B. Work which cannot for reasons acceptable to Engineer be covered with complete construction system before onset of weather detrimental to the Work shall be completely covered and protected in such a manner as to deflect water and weather from the installation without damaging adjacent Work.
  - C. Stone masonry units shall be protected from all damage and abuse from all other Contractors and installers involved in the Work until Final Acceptance by the City.
- 3.04 ADJUSTMENT
- A. Stone masonry unit components which are dislodged, damaged, expanded, broken, penetrated or crushed by subsequent installation operations or damaged by detrimental weather shall be immediately replaced with undamaged material in compliance with the Specifications and properly protected as specified.

END OF SECTION

**GENERAL SPECIFICATION 04400 – STONE MASONRY UNITS**

---

NO TEXT ON THIS PAGE

**SECTION 05081  
Galvanizing**

**PART 1 GENERAL**

**1.01 SECTION INCLUDES**

- A. Where galvanizing is called for on the Contract Drawings or in the Detailed Specifications, this Section covers all iron or steel materials which are to be galvanized.
- B. All galvanizing shall be done by the hot-dip process.
- C. The following index of this Section is included for convenience:

<u>Article</u>	<u>Title</u>	<u>Page</u>
		05081-
Part 1	General .....	1
1.01	Section Includes .....	1
1.02	Payment.....	1
1.03	References.....	1
1.04	Tests .....	3
1.05	Submittals .....	3
1.06	Qualifications.....	3
1.07	Shipping And Handling .....	3
Part 2	Products.....	4
2.01	Materials .....	4
Part 3	Execution .....	4
3.01	Preparation Of Materials.....	4
3.02	Method Of Galvanizing .....	4
3.03	Schedule Of Requirements .....	4
3.04	Repair Of Galvanized Coatings .....	5

**1.02 PAYMENT**

- A. No direct payment will be made for galvanizing, the cost for galvanizing shall be included in the prices for the work.

**1.03 REFERENCES**

- A. ASTM A53 - Pipe, Steel, Black and Hot-Dipped, Zinc-Coated Welded and Seamless

## GENERAL SPECIFICATION 05081 - GALVANIZING

---

- B. ASTM A90 - Test Method for Weight (Mass) of Coating on Iron and Steel Articles with Zinc or Zinc-Alloy Coatings
- C. ASTM A111 - Zinc-Coated (Galvanized) "Iron" Telephone and Telegraph Wire
- D. ASTM A116 - Zinc-Coated (Galvanized) Steel Woven Wire Fence Fabric
- E. ASTM A121 - Zinc-Coated (Galvanized) Steel Barbed Wire
- F. ASTM A123 - Zinc (Hot-Dip Galvanized) Coatings on Iron and Steel Products
- G. ASTM A143 - Practice for Safeguarding Against Embrittlement of Hot-Dip Galvanized Structural Steel Products and Procedure for Detecting Embrittlement
- H. ASTM A153 - Zinc Coating (Hot-Dip) on Iron and Steel Hardware
- I. ASTM A239 - Test Method for Locating the Thinnest Spot in a Zinc (Galvanized) Coating on Iron or Steel Articles by the Preece Test (Copper Sulfate Dip)
- J. ASTM A384 - Safeguarding Against Warpage and Distortion During Hot-Dip Galvanizing of Steel Assemblies
- K. ASTM A385 - Practice for Providing High-Quality Zinc Coatings (Hot-Dip)
- L. ASTM A392 - Zinc-Coated Steel Chain-Link Fence Fabric
- M. ASTM A475 - Zinc-Coated Steel Wire Strand
- N. ASTM A653 - Steel Sheet, Zinc-Coated (Galvanized) or Zinc-Iron Alloy-Coated (Galvannealed) by the Hot-Dip Process
- O. ASTM A780 - Practice for Repair of Damaged and Uncoated Areas of Hot-Dip Galvanized Coatings
- P. ASTM A924 - General Requirements for Steel Sheet, Metallic-Coated by the Hot-Dip Process
- Q. ASTM B6 - Specification for Zinc
- R. ASTM E536 - Test Methods for Chemical Analysis of Zinc and Zinc Alloys
- S. ANSI C80.1 - Rigid Steel Conduit, Zinc Coated
- T. American Galvanizers Association (AGA)
- U. Canadian Standards Association (CSA)

## GENERAL SPECIFICATION 05081 - GALVANIZING

---

### 1.04 TESTS

- A. General: Samples of galvanized articles shall be taken as specified in the appropriate ASTMs listed in Table 1. Galvanized articles shall be tested to determine the following qualities of the coating:
  - 1. Thickness of coating
  - 2. Adherence
  - 3. Uniformity.
- B. Thickness of the zinc coating may be tested either by the weighing or stripping methods in conformity with the requirements set forth in Table 1.
- C. Adherence of zinc coating shall be tested by the method indicated in the appropriate ASTMs listed in Table 1.
- D. Uniformity:
  - 1. Galvanized articles will be subjected to visual examination to determine uniformity of work.
  - 2. In the event the Engineer determines that such examination is not conclusive, the article shall be given the Preece test in conformity with ASTM A239.

### 1.05 SUBMITTALS

- A. The Contractor shall submit Shop Drawings for approval by the Engineer. The submittals shall include, but not be limited to:
  - 1. The producer's or supplier's certification that the galvanized articles were manufactured, sampled, tested and inspected in accordance with the applicable standards specified herein and that the articles meet these requirements
- B. When specified in the Detailed Specifications, a report of the test results shall be furnished to the Engineer.

### 1.06 QUALIFICATIONS

- A. Galvanizing shall be done in a plant having sufficient facilities to produce the quality of coatings herein specified and ample capacity for the volume of work required.
- B. The plant shall follow the procedures in the Quality Assurance Manual of the AGA.

### 1.07 SHIPPING AND HANDLING

- A. Galvanized articles shall be shipped and handled in a manner which will avoid damage to the zinc coating.

**PART 2 PRODUCTS**

**2.01 MATERIALS**

- A. Zinc used for galvanizing shall conform to ASTM B6, and shall be at least equal to the grade designated as Prime Western.
- B. Maximum amount of aluminum added to a galvanizing bath shall not exceed 0.01 percent.

**PART 3 EXECUTION**

**3.01 PREPARATION OF MATERIALS**

- A. Structural steel products shall be safeguarded against embrittlement in accordance with ASTM A143.
- B. Casting surfaces to be galvanized shall be sand blasted or ground smooth. When a smooth cast is required, castings shall be tumbled and all high spots ground flush. Castings shall be normalized to prevent cracking. Malleable iron shall be safeguarded against embrittlement by pre-annealing.
- C. Steel work shall be pre-cleaned utilizing a caustic bath, acid pickle and flux or shall be blast cleaned and fluxed to obtain an acceptable surface for quality hot dip galvanizing.

**3.02 METHOD OF GALVANIZING**

- A. All galvanizing shall be done by the hot-dip process in conformity with the appropriate ASTM Specifications listed in Table 1.
- B. Methods tending to agitate the dross shall not be used, and materials shall not contact the dross at any time.
- C. Chemical analysis for impurities in the bath shall be made in conformity with ASTM E536.

**3.03 SCHEDULE OF REQUIREMENTS**

- A. Table 1 - Schedule of Hot-Dip Galvanizing Requirements:
  - 1. The work shall conform to the requirements of the tabulated standards in Table 1 on the following pages.
- B. Notes Applicable to Table 1:
  - 1. Prefixes A, B and E identify ASTM Specifications; prefix G identifies CSA Standard.
  - 2. Where coating thicknesses are referenced to a table in the ASTMs, the coating thickness for the galvanized articles shall conform to the requirements given in the Detailed Specifications.

3. Galvanized articles shall not be subject to wiping or scraping processes which may reduce the thickness of zinc coating.
4. Small hardware items shall be centrifuged to remove excess bath metal.

C. Quality of Coating:

1. The zinc coating shall meet the standards set forth in Table 1, ASTM A385. The coating shall adhere firmly to the surface of the base metal, be continuous, uniform in thickness, and of the quality of finish specified.
2. When special galvanizing, such as heavier coating, flexibility to permit forming operations and similar work is required, it shall be so specified in the Detailed Specifications.
3. All rejected materials shall be stripped and regalvanized before resubmitting for inspection and test.

3.04 REPAIR OF GALVANIZED COATINGS

- A. Galvanized coatings that are abraded or damaged shall be repaired in accordance with ASTM A780.
- B. The extent of the area to be repaired and the method of repair to be used shall be approved by the Engineer.

(NO FURTHER TEXT ON THIS PAGE)

**GENERAL SPECIFICATION 05081 - GALVANIZING**

<b>TABLE 1 - SCHEDULE OF HOT-DIP GALVANIZING REQUIREMENTS</b>							
<b>CLASS OF WORK</b>	<b>ZINC</b>		<b>TEST OF ZINC COATING</b>				<b>COATING THICKNESS</b>
	<b>Slab &amp; Chemical Analysis</b>	<b>Coating</b>	<b>Thickness</b>		<b>Adherence</b>	<b>Uniformity</b>	<b>Oz. Per Sq. Ft.</b>
			<b>By Weight</b>	<b>By Stripping</b>			<b>Minimum</b>
<b>IRON &amp; STEEL STRUCTURAL</b> § Rolled, pressed and forged, shapes, castings, plates, bars and strips § Gratings, iron and steel	B6, E536	A123	A123	A90,	A123	A123, A239	Table 1, A123
<b>SHEETS</b> § Iron and steel	B6, E536	A653	A653, A924	A90, A924	A653	A239	Table 1, A653
<b>HARDWARE</b> § Castings of malleable iron and steel § Rolled, pressed, forged articles § Threaded fasteners § Very small work: rivets, nails, tacks, pins, small bolts and screws, stove bolts § Turnbuckles and similar work § Chain	B6, E536	A153	A153	A90,	A153	A153, A239	Table 1, A153
<b>WIRE</b> § Line wire § Fencing wire § Fencing fabric, chain link § Barbed wire § Strand wire	B6, E536 B6, E536 B6, E536 B6, E536 B6, E563	A111 A116 A392 A121 A475	-- -- -- -- --	A90 A90 A90 A90 A90	A111 -- -- -- A475	A111 -- -- -- A475	Table 1, A111 Table 3, A116 Tables 1 and 2, A392 Table 3, A121 Table 4, A475
<b>PIPE</b>	B6, E536	A53	--	A90	A53	--	1.8 oz. per sq. ft
<b>ELECTRICAL CONDUIT (Rigid Steel)</b>	Shall comply with ANSI C80.1 - Rigid Steel Conduit, Zinc Coated.						



**SECTION 05091  
Welding**

**PART 1 GENERAL**

**1.01 SECTION INCLUDES**

- A. The Contractor shall perform all structural welding as indicated on the Contract Drawings, required by the Detailed Specifications and as specified herein. The work shall include, but not limited to, the following items:
  - 1. Procedure specifications.
  - 2. Procedure qualifications.
  - 3. Welder, welding operator and tacker qualifications.
  - 4. Inspection.
  - 5. Testing and repair of defective welds.
- B. An index of the Articles in this Section is presented hereinafter for the convenience of the Contractor.

<u>Article</u>	<u>Title</u>	<u>Page</u>
		05091-
PART 1	GENERAL .....	1
1.01	Section Includes .....	1
1.02	Related Section .....	2
1.03	Payment.....	2
1.04	References.....	2
1.05	Definitions.....	2
1.06	General Requirements.....	2
1.07	Submittals .....	3
1.08	Welding Procedure Qualifications.....	3
1.09	Welder, Welding Operator And Tacker Qualification.....	4
1.10	Symbols .....	6
1.11	Safety Precautions.....	6
PART 2	PRODUCTS.....	6
2.01	Welding Equipment And Materials .....	6
PART 3	EXECUTION.....	6
3.01	Welding Requirements.....	6
3.02	Supervision .....	7
3.03	Inspection And Tests.....	7
3.04	Standards Of Acceptance.....	8
3.05	Corrections And Repairs.....	8

## GENERAL SPECIFICATION 05091 - WELDING

---

### 1.02 RELATED SECTION

- A. General Specification 05120 - Structural Steel.

### 1.03 PAYMENT

- A. Except as otherwise specified in the Detailed Specifications, no separate payment will be made for the work of this Section, the cost thereof shall be included in the lump sum price bid for the Contract.

### 1.04 REFERENCES

- A. AISC-04 - Specification for Structural Steel Buildings - Allowable Stress Design and Plastic Design.
- B. ANSI/AWS A2.4 - Standard Symbols for Welding, Brazing and Nondestructive Examination.
- C. ANSI/AWS A3.0 - Standard Welding Terms and Definitions.
- D. ANSI/AWS D1.1 - Structural Welding Code - Steel.
- E. ANSI/AWS D1.4 - Structural Welding Code - Reinforcing Steel.
- F. AWS Z49.1 - Safety in Welding and Cutting and Allied Processes.
- G. American Institute of Steel Construction (AISC).
- H. American Welding Society (AWS).
- I. New York City Building Code (NYBC).
- J. New York City Board of Standards (BS&A).

### 1.05 DEFINITIONS

- A. Definitions of welding terms shall be in accordance with ANSI/AWS A3.0.

### 1.06 GENERAL REQUIREMENTS

- A. All welding shall be performed in accordance with ANSI/AWS D1.1 and ANSI/AWS D1.4. No welding shall be performed when the base metal temperature is lower than 32 degrees Fahrenheit.
- B. Welding shall not be started until welding procedures, welders, welding operators and tackers have been qualified and copies of all records and reports submitted and approved by the Engineer.
- C. The Contractor shall be responsible for the quality of welding and shall maintain records of the test results obtained from the welding procedure, welder, welding operator and tackers performance qualifications.
- D. Each weld shown or indicated on the Contract Drawings shall be made as specified on the approved procedure specifications provided to cover each type

of weld. Welding of any special steel shall conform to the written instructions of the steel manufacturer.

- E. Test specimens shall be prepared by the Contractor for each type of welded joint as designated in Article 1.08, Welding Procedure Qualifications. Destructive tests of specimens for procedure and welder qualifications shall be conducted in accordance with ANSI/AWS D1.1, Section 4, Qualifications, and the requirements specified herein.

#### 1.07 SUBMITTALS

The Contractor shall prepare and submit Shop Drawings for approval of the Engineer. Submittals shall include, but not be limited to, the following:

1. Erection drawings, and catalog data on welding equipment and materials.
2. Welding procedure specifications.
3. Welding procedure qualifications and test records.
4. Welder, welding operator and tacker qualifications and test records.
5. Records of tests and inspections of installed welds.
6. Testing or inspection agency selection.

#### 1.08 WELDING PROCEDURE QUALIFICATIONS

- A. General: Except for prequalified or previously qualified procedures, the Contractor shall qualify the welding procedure specifications for any welding procedure performed in the fabrication of weldments. Qualifications of welding procedures shall conform to ANSI/AWS D1.1 and ANSI/AWS D1.4.
- B. Welding procedure specification and the results of the procedure qualification test for each type of welding, which requires procedure qualifications, shall be submitted for approval. Approval of any procedure, however, will not relieve the Contractor of the sole responsibility for producing a finished structure meeting all the requirements of these Specifications. This information shall be submitted on the forms in Annex E of ANSI/AWS D1.1.
  1. Procedures, when qualified, become the welding procedure specifications and are to be followed in making welds on the subject materials and provide a means of assuring reproducible results and quality control.
  2. Separate procedure specifications shall be prepared for each type of weld.
  3. Welding procedure specifications shall be individually identified and shall be referenced on the shop drawings and erection drawings, or shall be suitably keyed to the Contract Drawings.

## GENERAL SPECIFICATION 05091 - WELDING

---

- C. Previous Qualifications: Welding procedures previously qualified by test may be acceptable for this Contract without requalification if the following conditions are met:
1. Testing was performed by an approved testing laboratory.
  2. The qualified welding procedure conforms to the requirements of this Section and is applicable to welding conditions encountered under this Contract.
  3. The welder, welding operator and tacker qualification tests conform to the requirements of this Section and are applicable to welding conditions encountered under this Contract.
- D. Prequalified Procedures: Welding procedures which are considered prequalified as specified in ANSI/AWS D1.1 and ANSI/AWS D1.4, will be accepted without further qualification.
1. The Contractor shall submit for approval a listing and an annotated drawing to indicate the joints not prequalified.
  2. Procedure qualification shall be required for the joints not prequalified.
- E. Retests: If welding procedure fails to meet the requirements of ANSI/AWS D1.1 or ANSI/AWS D1.4, the procedure specification shall be revised and requalified.
1. At the Contractor's option, with the Engineer's approval, welding procedure may be retested in accordance with the standards.
  2. If the welding procedure is qualified through retesting, all test results, including those of test welds that failed to meet the requirements, shall be submitted with the welding procedure.

### 1.09 WELDER, WELDING OPERATOR AND TACKER QUALIFICATION

- A. General Information: Each welder, welding operator and tacker assigned to work on this Contract shall be certified in conformance with ANSI/AWS D1.1, Section 4. Welders shall also be New York City certified, and all welding shall be done in conformity with the NYBC and BS&A.
- B. Certificates: Before assigning any welder, welding operator or tacker to work under this Contract, the Contractor shall submit to the Engineer the names of the welders, welding operators and tackers to be employed and certification that each individual is qualified as specified.
1. The certification shall state the type of welding and positions for which the welder, welding operator or tacker is qualified, the code and procedure under which the individual is qualified, the date qualified, and the name of the firm and person certifying the qualification tests.

2. The certification shall be kept on file at the job site by the Contractor. The certification shall be kept current for the duration of the Contract.
- C. Identification of Welds: The Contractor shall assign each welder, welding operator or tacker an identifying number, letter or symbol which shall be used to identify all welds made by that person. For identification, the welder, welding operator or tacker shall apply the assigned symbol adjacent to the weld by means of a rubber stamp, felt tipped marker with waterproof ink or other methods that do not cause an indentation in the metal. Identification with die stamps or electric etches shall not be allowed.
- D. Record of Welds: The Contractor shall maintain a record of all welders, welding operators and tackers employed on the Contract showing the date and results of tests and the identification mark assigned to each person. These records shall be certified by the Contractor and copies of the records shall be furnished to the Engineer.
- E. Previous Qualifications: At the discretion of the Engineer, welders, welding operators and tackers qualified by test within the previous 6 months may be accepted for this Contract without requalification if all of the following conditions are met:
1. Copies of the welding procedure specifications, the procedure qualification test records, and the welder, welding operator, and tacker qualification test records are submitted and approved in accordance with the requirements shown on the Contract Drawings.
  2. Testing was performed by an approved testing laboratory.
  3. The previously-qualified welding procedure conforms to the requirements of this Section and is applicable to welding conditions encountered under this Contract.
  4. The welder, welding operator and tacker qualification tests conform to the requirements of this Section and are applicable to welding conditions encountered under this Contract.
- F. Renewal of Qualifications: Requalification of a welder or welding operator shall be required under any of the following conditions:
1. It has been more than 6 months since the welder or welding operator has used the specific welding process for which he is qualified.
  2. There is specific reason to question the welder or welding operator's ability to make welds that meet the requirements of these Specifications.
  3. The welder or welding operator was qualified by an employer other than those firms performing work under this Contract, and a qualification test has not been taken within the past 12 months. Records showing periods of employment, name of employer where welder, or welding operator,

## GENERAL SPECIFICATION 05091 - WELDING

---

was last employed, and the process for which qualified shall be submitted as evidence of conformance.

4. A tacker who passes the qualification test shall be considered eligible to perform tack welding indefinitely in the positions and with the processes for which he is qualified, unless there is some specific reason to question the tacker's ability. In such a case, the tacker shall be required to pass the prescribed tack welding test.

### 1.10 SYMBOLS

- A. Symbols on the Contract Drawings, shop drawings and erection drawings shall be in accordance with ANSI/AWS A2.4.

### 1.11 SAFETY PRECAUTIONS

- A. Safety precautions during welding shall conform to AWS Z49.1.

## PART 2 PRODUCTS

### 2.01 WELDING EQUIPMENT AND MATERIALS

- A. All welding equipment, electrodes, welding wire and fluxes shall be capable of producing satisfactory welds when used by a qualified welder or welding operator performing qualified welding procedures.
- B. All welding equipment and materials shall comply with the applicable requirements of ANSI/AWS D1.1 and ANSI/AWS D1.4.

## PART 3 EXECUTION

### 3.01 WELDING REQUIREMENTS

- A. Contract Drawings will include the following information:
  1. Size, length, type and location of welds.
  2. Location of welds for which non-destructive testing is required. When location of non-destructive testing is not shown, it will be indicated by the Engineer in the field.
- B. Workmanship and techniques for welded construction shall conform to the requirements of ANSI/AWS D1.1 and AISC-04. When ANSI/AWS D1.1 and AISC-04 are in conflict, the requirements of ANSI/AWS D1.1 shall govern.
- C. Welding of reinforcing shall conform to the requirements of ANSI/AWS D1.4 and the Detailed Specifications. Welds shall develop a minimum of 85,000 psi tensile strength. Bars to be welded shall be cut by means of an oxyacetylene torch or by sawing. Ends shall be free of dirt, oxide scale, oil, grease, or other foreign matter. Sheared ends of bars shall be trimmed back at least 1/2-inch by sawing or flame cutting. Preheat and interpass temperature shall conform to

ANSI/AWS D1.4. Bars having a carbon equivalent content in excess of 0.50 percent shall not be welded.

- D. Where dissimilar steel are welded together, the procedure used shall be the same as the one used for the lower strength steel.
- E. All groove welds shall be 100 percent complete penetration welds as defined in ANSI/AWS D1.1 or shown in ANSI/AWS D1.4 for reinforcing steel, regardless of whether a backup plate is shown or whether the supplementary backing weld or melt-through symbol is included, in each groove-weld symbol shown unless partial penetration is included in the weld symbol.
- F. Gun welded studs shall conform to the requirements of ANSI/AWS D1.1, Section 7.
- G. Upon completion of welding, all weld splatter, flux, slag and burrs left by attachments shall be removed. Welds shall be repaired to produce a workmanlike appearance with uniform weld contours and dimensions. All sharp corners of material which is to be painted or coated shall be ground to a minimum of 1/32-inch on the flat.

### 3.02 SUPERVISION

- A. All shop and field welding shall be under the immediate supervision of a representative of a standard testing agency or an approved inspection agency reporting directly to, and under the control of, the Department of Environmental Protection.
- B. Procedures and techniques for inspection shall be in accordance with the applicable requirements of ANSI/AWS D1.1. The Contractor shall submit the name of such agency to the Commissioner for approval before starting work.
- C. The costs of all welding inspections and tests shall be borne by the Contractor.

### 3.03 INSPECTION AND TESTS

- A. The Engineer will make periodic checks of each welder to determine that welds are being made as specified in the approved procedure specifications. Welding speed may be estimated.
- B. All welds will receive 100 percent visual inspection to determine weld size and profile, surface cracks, overlap, and undercut.
- C. Welds shall receive non-destructive testing as required in General Specification 05120 - Structural Steel.
- D. The Engineer reserves the right to perform any additional test on any weld, including liquid penetrant, magnetic particle, radiographic, and ultrasonic. The costs of such testing will be borne by the Contractor if unsatisfactory welds are discovered, or by the City if the welds are satisfactory.

3.04 STANDARDS OF ACCEPTANCE

- A. Dimensional tolerances for welded construction, details of welds, and quality of welds shall be in accordance with the applicable requirements of ANSI/AWS D1.1, ANSI/AWS D1.4 and the Contract Drawings.
- B. The welding shall be subject to inspection and tests in the shop and project site. Inspection and tests in the shop will not relieve the Contractor of the responsibility to furnish weldments of satisfactory quality.
- C. All welding exhibiting any cracks, either in the weld metal or the parent metal, will be rejected.
- D. Incomplete fusion or lack of penetration will not be allowed, and the weld will be rejected.
- E. Welds, other than stud welds, are acceptable if inspection indicates conformance within the following limitations:
  - 1. Undercut shall not be more than 1/32-inch deep.
  - 2. Convexity or reinforcement of a weld face shall not exceed the limits shown in ANSI/AWS D1.1, Section 3 and there shall be no overlap.
  - 3. Slag inclusions, porosity and other fusion defects less than 1/16-inch in greatest dimension will be allowed if well dispersed and the sum of the greatest dimensions in any linear inch of welded joint does not exceed 3/8-inch.
  - 4. Slag inclusions, porosity and other fusion defects 1/16-inch or larger in greatest dimension will be allowed providing such defects do not exceed the limits specified in ANSI/AWS D1.1.
- F. When materials or workmanship do not conform to the acceptance requirements, the Engineer reserves the right to reject material or workmanship or both at any time before final acceptance of the structure containing the weldment.

3.05 CORRECTIONS AND REPAIRS

- A. General: In lieu of rejection of an entire piece or member containing welding which is unsatisfactory or which indicates inferior workmanship, the corrective measures listed hereinafter may be permitted by the Engineer. The Engineer's specific approval must be obtained before making each correction. Corrective measures shall be made at the Contractor's expense and to the satisfaction of the Engineer and/or an acceptable independent testing lab.
- B. Defective or unsound welds or base metal shall be corrected either by removing and replacing the entire welds, or as follows:
  - 1. Excessive convexity and overlap shall be reduced by removal of excess weld metal.



## GENERAL SPECIFICATION 05091 - WELDING

---

2. Any concavity of weld, crater, undersize welds or undercutting shall be corrected by cleaning and depositing additional weld metal.
  3. Excessive weld porosity, slag, inclusions or incomplete fusion shall be repaired by removing defective portions and rewelding.
  4. Cracks in weld or base metal shall be repaired by removing crack throughout its length, including sound weld metal 2 inches beyond each end of the crack and rewelding.
- C. The removal of defective weld metal or portions of the base metal shall be done by chipping, grinding, oxygen cutting, oxygen gouging, or air carbon-arc and in such a manner that the remaining weld metal or base metal is not nicked or undercut. Defective portions of the weld shall be removed without removal of the base metal.
- D. Additional weld metal shall be deposited using an electrode smaller than that used for making the original weld, and not more than 5/32 inch diameter. The surface shall be cleaned thoroughly before welding.
- E. Caulking of welds shall not be permitted.
- F. Improperly fitted parts may be cut apart and rewelded. Members distorted by welding shall be straightened by mechanical means or by carefully supervised application of a limited amount of localized heat.
1. The temperature of heated areas shall not exceed 1,200 degrees Fahrenheit (a dull red color). Temperature shall be carefully measured with temperature indicating crayons during the heating operation.
  2. Parts to be heated for straightening shall be substantially free of stress and from external forces, except those stresses resulting from mechanical means used in conjunction with the application of heat.
- G. No peening shall be done on the root or surface layers of a weld. Peening of intermediate weld layers may be used only if authorized by the Engineer and directed by him. Care shall be exercised to prevent overpeening which may cause overlapping, scaling, cracking, flaking, or excessive cold working of weld and base metal.

END OF SECTION

**GENERAL SPECIFICATION 05091 - WELDING**

---

NO TEXT ON THIS PAGE

**SECTION 05092  
Metal Fastening**

**PART 1 GENERAL**

**1.01 SECTION INCLUDES**

- A. The Contractor shall furnish all materials, labor, and equipment required to provide all metal fastening in accordance with the Contract Drawings and these Specifications.
- B. The following index of this Section is included for convenience:

<u>Article</u>	<u>Title</u>	<u>Page</u>
		05092-
PART 1	GENERAL .....	1
1.01	Section Includes .....	1
1.02	Related Sections .....	1
1.03	References .....	2
1.04	Submittals .....	3
1.05	Quality Assurance .....	3
1.06	Delivery, Storage And Handling .....	3
PART 2	PRODUCTS .....	4
2.01	Anchor Bolts .....	4
2.02	Bolts .....	4
2.03	Stainless Steel Bolts .....	4
2.04	Concrete Anchors .....	5
2.05	Concrete Inserts .....	7
2.06	Masonry Anchors .....	7
2.07	Welds .....	8
2.08	Eyebolts .....	8
2.09	Titanium Bolts And Anchors .....	8
PART 3	EXECUTION .....	9
3.01	Examination .....	9
3.02	Installation .....	9
3.03	Welding .....	10
3.04	Inspection .....	10

**1.02 RELATED SECTIONS**

- A. General Specification 05081 - Galvanizing.
- B. General Specification 05091 - Welding.

## GENERAL SPECIFICATION 05092 - METAL FASTENING

---

C. General Specification 05120 - Structural Steel.

### 1.03 REFERENCES

- A. ASTM A36 - Carbon Structural Steel.
- B. ASTM A307 - Carbon Steel Bolts and Studs, 60,000 psi Tensile Strength.
- C. ASTM A325 - Structural Steel Bolts, Steel Heat Treated, 120/105 ksi Minimum Tensile Strength.
- D. ASTM A489 - Carbon Steel Lifting Eyes.
- E. ASTM A490 - Heat Treated Steel Structural Bolts, 150 ksi, Minimum Tensile Strength.
- F. ASTM A563 - Carbon and Alloy Steel Nuts.
- G. ASTM B348 - Titanium and Titanium Alloy Bars and Billets.
- H. ASTM D1785 - Standard Specification for Polyvinyl Chloride (PVC) Plastic Pipe, Schedules 40, 80 and 120.
- I. ASTM E120 Withdrawn. - Test Methods for Chemical Analysis of Titanium and Titanium Alloys.
- J. ASTM F467 - Nonferrous Nuts for General Use.
- K. ASTM F593 - Stainless Steel Bolts; Hex Cap Screws, and Studs.
- L. ASTM F594 - Stainless Steel Nuts.
- M. ANSI/AWS D1.6 - Structural Welding Code B Stainless Steel.
- N. ANSI/AWS D1.1 - Structural Welding Code - Steel.
- O. ANSI/AWS D1.2 - Structural Welding Code - Aluminum.
- P. New York City Building Code (NYBC).
- Q. American Institute of Steel Construction (AISC).
- R. Code of Standard Practice for Steel Buildings and Bridges (AISC).
- S. Specification for Structural Joints Using ASTM A325 or A490 Bolts (AISC).
- T. Aluminum Association - Specifications for Aluminum Structures.

1.04 SUBMITTALS

- A. The Contractor shall submit Shop Drawings and material specifications for approval by the Engineer. Submittal shall include, but not be limited, to:
  - 1. Shop Drawings providing the manufacturer, current catalog, fastener type, certification of the fastener's material and capacity and installation requirements.
  - 2. Copy of valid AWS certification for each person who is to perform field welding.
  - 3. Certified weld inspection reports, when required.
  - 4. Certified test reports for chemical analysis of titanium bolts, washers and nuts in accordance with ASTM E120 Withdrawn.

1.05 QUALITY ASSURANCE

- A. Fasteners not manufactured in the United States shall be tested and certification provided with respect to specified quality and strength standards. Certifications of origin shall be submitted for all U.S. fasteners supplied on the project. Fasteners to be tested shall be randomly selected by the Engineer in the field.
- B. All steel welding shall be performed by welders certified in accordance with AWS D1.1. All aluminum welding shall be performed by welders certified in accordance with AWS D1.2. Certifications of field welders shall be submitted prior to performing any field welds.
- C. Fasteners and concrete anchors will be inspected in accordance with Article 3.04.
- D. The City may engage an independent testing agency to perform testing of welded connections and to prepare test reports in accordance with AWS. Inadequate welds shall be corrected or redone and retested to the satisfaction of the Engineer and/or an acceptable independent testing laboratory, at no additional cost to the City.
- E. Manufacturer's load tables and certified performance tests for titanium bolts shall be provided.

1.06 DELIVERY, STORAGE AND HANDLING

- A. Materials stored outdoors shall be supported above ground surfaces and protected with approved effective and durable covers.

**PART 2 PRODUCTS**

**2.01 ANCHOR BOLTS**

- A. Anchor bolts for miscellaneous framing and architectural elements attachments shall conform to ASTM A36 or ASTM A307 Grade A except where stainless steel or other approved anchor bolts are shown on the Contract Drawings. Anchor bolts shall be of the size and configuration shown on the Contract Drawings and shall be supplied with hexagonal nuts meeting the requirements of ASTM A563 Grade A.
- B. Anchor bolts for equipment attachment shall be of stainless steel Type 316 with nitronic 60 stainless steel nuts and locknuts.
- C. All underwater anchor bolts shall be Type 316 stainless steel with nitronic 60 stainless steel nuts.
- D. Where anchor bolts are used to anchor galvanized steel or are otherwise specified to be galvanized, they shall be hot-dip galvanized in accordance with ASTM A307 and General Specification 05081 - Galvanizing.
- E. Pipe sleeves around anchor bolts shall be of the size and configuration shown on the Contract Drawings.
- F. Material for anchor bolts submerged in salt water or corrosive liquids for which stainless steel Type 316 is not suitable shall be as indicated in the Detailed Specifications.

**2.02 BOLTS**

- A. Bolts, nuts and washers for miscellaneous framing and for attachment of architectural elements shall conform to Paragraph 2.02A of General Specification 05120 - Structural Steel.
- B. Where bolts are used to connect galvanized steel or are otherwise specified to be galvanized, bolts, nuts, and washers shall be hot-dip galvanized in accordance with General Specification 05081 - Galvanizing.

**2.03 STAINLESS STEEL BOLTS**

- A. Stainless steel bolts shall conform to ASTM F593. All underwater fasteners shall be Type 316 stainless steel. Unless otherwise specified, fasteners for aluminum members shall be Type 304 stainless steel. Fasteners for stainless steel members shall be of matching grade.
- B. Stainless steel bolts shall have hexagonal heads with a raised letter or symbol on the bolts indicating the manufacturer, and shall be supplied with hexagonal nuts meeting the requirements of ASTM F594. Nuts

shall be of the same alloy as the bolts and shall have a raised letter or symbol indicating the manufacturer.

- C. Nuts for stainless steel bolts for elements which are indicated on the Contract Drawings to be removable shall be made of nitronic 60 alloy.
- D. Material for bolts submerged in salt water or corrosive liquids for which stainless steel Type 316 is not suitable shall be as indicated in the Detailed Specifications.

2.04 CONCRETE ANCHORS

- A. Concrete anchors shall be one of the types listed below as indicated on the Contract Drawings. Unless otherwise noted, all concrete anchors which are submerged, or which are subject to vibration from equipment such as pumps and generators, shall be injected, adhesive anchors. The determination of anchors equivalent to those listed below shall be on the basis of test data performed by a commercial testing laboratory. There are two categories used:
  - 1. Expansion anchors shall be wedge, sleeve, or drop-in mechanical anchors.
  - 2. Adhesive anchors shall be two part injection type.
  - 3. Where anchor type is not indicated on the Contract Drawings, the wedge expansion anchor shall be used.
- B. Expansion anchors shall be:
  - 1. Kwik Bolt II as manufactured by Hilti Inc., Plano, TX.
  - 2. Trubolt Wedge Anchor as manufactured by ITW Ramset/Redhead, Michigan City, IN.
  - 3. Power-Stud as manufactured by Powers/Rawl, New Rochelle, NY.
  - 4. Or approved equal.
- C. Expansion anchors shall be embedded to the depths shown on the Contract Drawings. If no embedment depth is given, the standard embedment depth as recommended by the manufacturer shall be used.
- D. Sleeve or drop-in anchors shall be as manufactured by:
  - 1. Hilti Inc., Plano, TX.
  - 2. ITW Ramset/Red Head, Michigan City, IN.
  - 3. Powers/Rawl, New Rochelle, NY.
  - 4. Or approved equal.

**GENERAL SPECIFICATION 05092 - METAL FASTENING**

---

- E. Adhesive anchors shall consist of threaded rods or bolts anchored with an adhesive system into hardened concrete or grout-filled masonry. The adhesive system shall use a two-component adhesive mix and shall be injected with a static mixing nozzle following manufacturer's instructions. The embedment depth of the rod/bolt shall provide a minimum allowable bond strength that is equal to the allowable tensile capacity of the rod/bolt (see Table 1) unless noted otherwise on the Contract Drawings. The adhesive system shall be:
  - 1. "Epcon System Ceramic 6" as manufactured by ITW Ramset/Redhead, Michigan City, IN.
  - 2. "HIT HY-150 Injection Adhesive Anchor System" as manufactured by Hilti Inc., Plano, TX.
  - 3. Powerfast by Powers/Rawl, New Rochelle, NY.
  - 4. Or approved equal.
- F. Concrete anchors shall be of Stainless Steel Type 304 unless noted otherwise. Concrete anchors for stainless steel attachments shall be of matching grade.
- G. All underwater concrete anchors shall be Type 316 stainless steel and shall have nitronic 60 stainless steel nuts.
- H. Material for concrete anchors submerged in salt water or other corrosive liquids for which stainless steel Type 316 is not suitable shall be as indicated in the Detailed Specifications.

<b>Table 1 Allowable Tensile Capacity (Kips) for Standard Manufacturer Embedment</b>		
<b>Size</b>	<b>Concrete Anchors Wedge Type</b>	<b>Concrete Anchors with Injection Adhesive System</b>
3/8"	1.3	2.1
1/2"	2.4	3.8
5/8"	3.3	5.9
3/4"	4.8	8.4
7/8"	5.6	11.0
1"	7.1	15.0



2.05 CONCRETE INSERTS

A. Wedge Type Inserts:

1. For attachment of shelf angles or brick relieving angles to the reinforced concrete beams or concrete encased steel beams, the concrete inserts shall be wedge type inserts. The inserts shall have an askew head bolt to produce an automatic tightening action when a load is placed on the bolt.
2. The wedge inserts shall be of malleable iron, hot dipped galvanized. The askew bolt and the horseshoe shim plates shall be of stainless steel Type 304. The type of insert and size of bolts shall be as shown on the Contract Drawings.
3. The wedge inserts shall be:
  - a. As manufactured by Hohmann & Barnard, Inc., Hauppauge, NY.
  - b. Or approved equal.

B. Anchor Channel Inserts: for the top attachment of the masonry wall panels to steel encased or concrete structures, the inserts shall be:

1. Anchor channel as manufactured by:
  - a. Halfen Anchoring Systems, Tampa, FL.
  - b. Or approved equal.
2. The anchor channel shall be made from channel profiles with "I" anchors shop welded to the back of channels. Anchor channels shall be furnished with the head bolts, channel nuts, etc., for a complete installation. All material shall be stainless steel type 304.
3. The type and series of the anchor channel shall be as shown on the Contract Drawings.
4. Anchor channels can be used for other attachments if detailed on the Contract Drawings.

2.06 MASONRY ANCHORS

A. Masonry anchors shall be injection adhesive anchors with screen tube for fastening to hollow block, clay tiles and brick with holes (see Table 2).

B. The adhesive system shall be:

1. "Hit HY-20", as manufactured by Hilti Inc., Plano, TX.

## GENERAL SPECIFICATION 05092 - METAL FASTENING

2. "Epcon System Ceramic 6" as manufactured by ITW Ramset/Redhead, Michigan City, IN.
  3. Powerfast by Powers/Rawl, New Rochelle, NY.
  4. Or approved equal.
- C. Masonry anchors shall be of stainless steel type 304 unless noted otherwise. Masonry anchors for stainless steel attachments shall be of the matching grade.

<b>Size</b>	<b>Masonry Anchors with Injection Adhesive System</b>
1/4"	255
5/16"	370
3/8"	525
1/2"	525

### 2.07 WELDS

- A. Electrodes for welding carbon steel shall comply with Article 2.01D. of General Specification 05120 - Structural Steel.
- B. Electrodes for welding aluminum shall comply with the Aluminum Association Specifications and AWS D1.2.
- C. Electrodes for welding stainless steel and other metals shall comply with AWS A5.4.

### 2.08 EYEBOLTS

- A. Eyebolts shall be of the size indicated on the Contract Drawings and shall conform to ASTM A489 unless noted otherwise.
- B. Carbon steel eyebolts shall be galvanized in accordance with General Specification 05081 - Galvanizing.

### 2.09 TITANIUM BOLTS AND ANCHORS

- A. Titanium bolts, washers, nuts and anchors shall be provided in, over, and adjacent to containment areas for ferric chloride and sodium hypochlorite, unless indicated otherwise on the Contract Drawings.
- B. Bolts and anchors shall be of the size indicated on the Contract Drawings. Bolts, anchors washers and nuts and shall conform to ASTM B348, Grade 2.

- C. Minimum mechanical and physical properties:
  - 1. Tensile Strength            50,000 psi
  - 2. Yield Strength            40,000 psi
  - 3. Elongation in 4" dia.    20%
  - 4. Modulus of Elasticity    14.9x10<sup>6</sup> psi

**PART 3            EXECUTION**

**3.01            EXAMINATION**

- A. The Contractor shall field verify all dimensions and condition of the materials to be connected, review the Drawings and report any discrepancies to the Engineer for clarification prior to starting fabrication.

**3.02            INSTALLATION**

- A. Anchor Bolts and Concrete Anchors:

- 1. Anchor bolts shall be installed in accordance with AISC "Code of Standard Practice" by setting in concrete while it is being placed and positioned by means of a rigidly held template.
- 2. The installation of concrete anchors shall be done in strict conformance with the manufacturer's field demonstration and recommendations.
- 3. The holes drilled for adhesive anchors shall be cleaned by use of a fiber bristle brush and dry compressed air. The anchors shall be supported in the correct position until the adhesive sets and gains enough strength to prevent any dislocation. Adhesive anchors shall not be tightened or loaded until the adhesive has fully cured as recommended by the manufacturer.
- 4. No concrete anchor shall be installed before base concrete has attained specified 28-day strength.
- 5. Concrete anchors shall not be used in place of anchor bolts without Engineer's approval.

- B. Bolts:

- 1. All steel bolts shall be installed in conformance with General Specification 05120 - Structural Steel.
- 2. Unless otherwise specified, where aluminum and steel members are connected together they shall be fastened with Type 304 stainless steel bolts and isolated with micarta, nylon, rubber, or approved equal.

## GENERAL SPECIFICATION 05092 - METAL FASTENING

---

- C. Concrete Inserts: Provide concrete inserts where shown on the Contract Drawings. Inserts shall be firmly held in position in the forms and sealed from intrusion of concrete mortar during concrete placement.
- D. Titanium Bolts
  - 1. All bolts shall be installed in conformance with the manufacturer's recommendations.
  - 2. Titanium anchors shall be installed in accordance with AISC "Code of Standard Practice" by setting in concrete while it is being placed and positioned by means of a rigidly held plate.

### 3.03 WELDING

- A. Welding shall comply with the requirements of General Specifications 05120 - Structural Steel and 05091 - Welding.

### 3.04 INSPECTION

- A. Inspection for high strength bolted connections shall conform to the requirements of General Specification 05120 - Structural Steel.
- B. At least 25 percent of the concrete anchors required to be installed shall be proof tested to 1.33 times the allowable load specified by the manufacturer of the system.
- C. Welding inspection shall be done in accordance with the requirements of General Specifications 05120 - Structural Steel and 05091 - Welding.
- D. Inspection of titanium bolted connections shall conform to the requirements of AISC "Code of Standard Practice."

END OF SECTION

**SECTION 05120  
Structural Steel**

**PART 1 GENERAL**

**1.01 SECTION INCLUDES**

- A. The Contractor shall furnish all equipment, materials, and services for the fabrication, delivery, unloading, handling, storing, and erection of all structural steel Work as shown on the Contract Drawings and called for herein.
- B. Unless otherwise shown, specified or required, design, workmanship and erection shall conform to or exceed the applicable requirements of the documents listed hereinafter in Article 1.04 to the extent that the provisions of such documents are not in conflict with the requirements of this Section.
- C. An index of the Articles in this Section is presented hereinafter for the convenience of the Contractor.

<u>Article</u>	<u>Title</u>	<u>Page</u>
		05120-
PART 1	GENERAL.....	1
1.01	Section Includes.....	1
1.02	Related Sections.....	1
1.03	Measurement And Payment.....	2
1.04	References.....	2
1.05	Definition.....	4
1.06	Submittals.....	4
1.07	Quality Assurance.....	4
1.08	Delivery, Storage And Handling.....	6
1.09	Field Measurements.....	6
PART 2	PRODUCTS.....	6
2.01	Structural Steel.....	6
2.02	Bolts.....	7
2.03	Anchor Bolts.....	7
2.04	Welding Electrodes.....	7
PART 3	EXECUTION.....	8
3.01	Fabrication.....	8
3.02	Erection.....	9
3.03	Frame Assembly.....	11
3.04	Painting.....	11
3.05	Galvanizing.....	12

**1.02 RELATED SECTIONS**

- A. General Specification 05081 - Galvanizing

## GENERAL SPECIFICATION 05120 - STRUCTURAL STEEL

---

- B. General Specification 05091 - Welding
- C. General Specification 09900 - Painting

### 1.03 MEASUREMENT AND PAYMENT

- A. No separate payment will be made for performing any Work required under this Section and the Contractor shall include all costs thereof in its lump sum price bid for the Contract.
- B. The quantity, in pounds, to be measured for payment shall be in accordance with the latest Code of Standard Practice for Steel Buildings and Bridges of the AISC.
- C. The weights of bolts, nuts, ties, anchors and other material, used only for erection or for the Contractor's convenience, shall not be included for payment.

### 1.04 REFERENCES

- A. ASTM:
  - 1. A6 - General Requirements for Rolled Structural Steel Bars, Plates, Shapes and Sheet Piling
  - 2. A36 - Carbon Structural Steel
  - 3. A53 - Pipe, Steel, Black and Hot-Dipped, Zinc-Coated Welded and Seamless
  - 4. A193 - Alloy-Steel and Stainless Steel Bolting Materials for High-Temperature Service
  - 5. A194 - Carbon and Alloy Steel Nuts for Bolts for High-Pressure and High-Temperature Service
  - 6. A307 - Carbon Steel Bolts and Studs, 60,000 psi Tensile Strength
  - 7. A500 - Cold-Formed Welded and Seamless Carbon Steel Structural Tubing in Rounds and Shapes
  - 8. A501 - Hot-Formed Welded and Seamless Carbon Steel Structural Tubing
  - 9. A563 - Carbon and Alloy Steel Nuts
  - 10. A572 - High-Strength Low-Alloy Columbium-Vanadium Structural Steel
  - 11. A588 - High-Strength Low-Alloy Structural Steel with 50 ksi Minimum Yield Point to 4-Inches Thick
  - 12. A992 - Standard Specification for Steel for Structural Shapes for Use in Building Framing

## GENERAL SPECIFICATION 05120 - STRUCTURAL STEEL

---

13. F436 - Hardened Steel Washers, Inch and Metric Dimensions
  14. F 594 - Stainless Steel Nuts
  15. F3125 - High Strength Structural Bolts, Steel and Alloy Steel, Heat Treated, 120 ksi & 150 ksi Minimum Tensile Strength, Inch and Metric Dimensions
- B. ANSI B18.2.1 - Square and Hex Bolts and Screws-Inch Series.
- C. ANSI B18.22.1 - Plain Washers
- D. ANSI/ASME B18.2.2 - Square and Hex Nuts (Inch Series)
- E. American Welding Society (AWS):
1. A5.1 - Carbon Steel Covered Arc-Welding Electrodes
  2. A5.5 - Low-Alloy Steel Covered Arc-Welding Electrodes
  3. A5.9 - Corrosion-Resisting Chromium and Chromium-Nickel Steel Bare and Composite Metal Cored and Stranded Arc Welding Electrodes and Welding Rods
  4. A5.17 - Carbon Steel Electrodes and Fluxes for Submerged-Arc Welding
  5. A5.18 - Filler Metals for Gas Shielded Arc Welding, Carbon Steel
  6. A5.23 - Low-Alloy Steel Electrodes and Fluxes for Submerged Arc Welding
  7. D1.1 - Structural Welding Code
  8. QC1 - Qualification and Certification of Welding Inspectors
- F. New York City Building Code (NYCBC)
- G. New York City Department of Buildings (NYCDOB)
- H. American Institute of Steel Construction (AISC):
1. Steel Construction Manual
  2. AISC 303 - Code of Standard Practice for Steel Buildings and Bridges
  3. AISC 360 - Specification for Structural Steel Buildings
  4. RSCS Specifications for Structural Joints Using High-Strength Bolts
  5. Design Guide 24 - Hollow Structural Sections
- I. Steel Structures Painting Council (SSPC)

1.05 DEFINITION

- A. Structural Steel: The term structural steel shall be as defined in the Codes of Standard Practice for Steel Buildings and Bridges of the AISC. Included as structural steel shall be all stiffeners, plates, sag rods and other miscellaneous metal required for a complete installation.

1.06 SUBMITTALS

- A. The Contractor shall submit Shop Drawings and material specifications for the approval of the Engineer. Submittals shall include, but not be limited to:
  - 1. Layout drawings indicating all materials, structural shapes, sizes, and dimensions.
  - 2. Beam and column schedules.
  - 3. Detail drawings indicating connection and anchoring details.
  - 4. Anchor bolts and setting plans.
  - 5. Erection drawings
- B. No fabrication shall be started until Shop Drawings have been approved in writing by the Engineer.
- C. The Contractor shall also submit the following:
  - 1. Certified mill test reports
  - 2. Affidavit of compliance with grade specified
  - 3. Certified weld inspection reports
  - 4. Certification for bolts
  - 5. Paint certification
  - 6. Quality certifications for fabricators and erectors.
- D. The Contractor shall furnish samples for testing, if required by the Detailed Specifications.

1.07 QUALITY ASSURANCE

- A. All fabrication and erection shall be performed by AISC Quality Certified Companies.
- B. Shop inspections may be made by the City representatives. The Contractor shall give ample notice to the Engineer prior to the beginning of any fabrication Work so that inspection may be provided. The Contractor shall furnish all facilities for the inspection of materials and workmanship in the shop, and the inspectors shall be allowed free access to the necessary parts of the works.
  - 1. Inspectors shall have the authority to reject any materials or work which does not meet the requirements of these Specifications.



## GENERAL SPECIFICATION 05120 - STRUCTURAL STEEL

---

2. Inspection at the shop is intended as a means of facilitating the work and avoiding errors, but is expressly understood that it will in no way relieve the Contractor from his responsibility for furnishing proper materials or workmanship under this Specification.
- C. All welding shall be performed by certified welders under the immediate supervision of a representative of a standard testing agency or a special inspection agency reporting directly to and under the control of the City and meeting the requirements of Section 05091 – Welding.
- D. The Contractor shall submit the name of such testing agency to the Commissioner for approval before starting Work.
1. All shop and field welds in structural steel shall be visually inspected by an AWS qualified welding inspector. The Contractor shall furnish a letter of certification for each welded connection stating that these requirements have been met.
  2. The costs of all welding supervision and inspections shall be borne by the Contractor. The Contractor shall engage inspectors to inspect welded connections and to perform tests and prepare test reports.
  3. Ten (10) percent of all butt and bevel welds which extend continuously for 24 inches or less will be completely tested in accordance with AWS D1.1, Part B, Radiographic Testing of Welds, Chapter 6. All butt and bevel welds which extend continuously for more than 24 inches will be spot tested at intervals not exceeding 36 inches.
  4. Welds that are required by the Engineer and/or inspectors to be corrected shall be corrected or redone and retested as directed, at the Contractor's expense and to the satisfaction of the Engineer and/or an acceptable independent testing lab.
- E. The Contractor shall engage an independent testing and inspection agency to inspect high-strength bolted connections. The agency shall report directly and be under the control of the City. The costs of all high-strength bolt inspections shall be borne by the Contractor.
1. Rejected bolts shall be either replaced or retightened as required. In cases of disputed bolt installation, the bolts in question shall be checked by a calibrated wrench certified by an independent testing laboratory. The certification shall be at the Contractor's expense.
- F. The Contractor shall be solely responsible for the correctness of all shop and field fabrication and fit.

1.08 DELIVERY, STORAGE AND HANDLING

- A. Structural members shall be loaded in such a manner that they may be transported and unloaded without being over-stressed, deformed or otherwise damaged.
- B. Structural steel members and packaged materials shall be protected from corrosion and deterioration. Material shall be stored in a dry area.
- C. Materials stored outdoors shall be supported above ground surfaces on wood runners and protected with approved effective and durable covers.
- D. Materials shall not be placed on the structure in a manner that might cause distortion or damage to the members or the supporting structures. The Contractor shall repair or replace damaged materials or structures as directed by the Engineer.

1.09 FIELD MEASUREMENTS

- A. The Contractor shall verify all dimensions and shall make any field measurements necessary and shall be fully responsible for accuracy and layout of the work.
- B. The Contractor shall review the Contract Drawings and any discrepancies shall be reported to the Engineer for clarification prior to starting fabrication.

PART 2 PRODUCTS

2.01 STRUCTURAL STEEL

- A. The fabricator shall provide an affidavit stating that the structural steel furnished meets the requirements of the grade specified. All unidentified steel will be rejected and shall be removed from the site and replaced by the Contractor, at no additional cost to the City.
- B. Structural steel for W shapes shall conform to ASTM A992 unless otherwise indicated.
- C. Structural steel for S, M, and HP shapes and channels shall conform to ASTM A572 Grade 50 unless otherwise indicated.
- D. Structural steel for angles and plates shall conform to ASTM A36 unless otherwise indicated.
- E. Certified mill test reports or certified reports of tests made by the fabricator or a testing laboratory for structural steel in accordance with ASTM A6 and the governing specification shall constitute evidence of conformity with the ASTM Specification.
- F. Steel pipe shall be ASTM A53, Type E or S, Grade B.

## GENERAL SPECIFICATION 05120 - STRUCTURAL STEEL

---

- G. Structural tubing shall be ASTM A500, Grade B. All members shall be furnished full length without splices unless otherwise noted or accepted by the Engineer.
  - H. Low alloy, high strength, high corrosion resistant steel shall conform to ASTM A 588.
  - I. High strength Columbium-Vanadium structural steel shall conform to ASTM A 572, Grade 50.
- 2.02 BOLTS
- A. High strength bolts shall conform to ASTM F3125. Other bolts shall conform to ASTM A307. Unless otherwise indicated, all bolts shall be ASTM F3125.
  - B. Galvanized high strength bolts shall conform to ASTM F3125, Type 1, nuts shall conform to ASTM A563. Galvanizing shall be by the hot-dip process and in accordance with General Specification 05081 - Galvanizing.
    - 1. Nuts shall meet the requirements of either ASTM A563 for Grade DH, or ASTM A194 for Grade 2H.
    - 2. Flat circular washers and square or rectangular beveled washers shall conform to the requirements of ASTM F436.
    - 3. Bolt dimensions shall conform to the requirements for regular semi-finished hexagon bolts, ANSI B18.2.1., unless otherwise specified.
    - 4. Nut dimensions shall conform to requirements for heavy hexagon semi-finished nuts ANSI/ASME B18.2.2. Washers shall be flat and smooth and their dimensions shall conform to the requirements for heavy plain washers, ANSI B18.22.1.
  - C. Bolts used to connect dissimilar metals or located in a corrosive atmosphere, as indicated on the Contract Drawings or specified in the Detailed Specifications, shall be Type 316 stainless steel conforming to ASTM A193 and A194.
  - D. Bolts not manufactured in the United States shall be tested and certification provided with respect to specified and required quality and strength standards. Certification of origin shall be provided for all United States fasteners. Bolts to be tested will be randomly selected in the field by the Engineer.
- 2.03 ANCHOR BOLTS
- A. Anchor bolts for structural steel shall be of the size and configuration shown on the Contract Drawings and shall conform to ASTM A307 unless shown or noted otherwise on the Contract Drawings.
- 2.04 WELDING ELECTRODES
- A. Welding electrodes for manual shielded metal arc welding shall conform to ANSI/AWS A5.1. Carbon steel electrodes and granular flux for the submerged-

arc welding process shall conform to ANSI/AWS A5.17 and low-alloy steel electrodes and fluxes for submerged arc-welding shall conform to ANSI/AWS A5.23 as required for the conditions of actual use.

- B. Welding electrodes for ASTM A36 steel shall comply with ANSI/AWS A5.1 (minimum tensile strength of 72,000 psi) and shall be E70XX.
- C. Welding electrodes for ASTM A588, ASTM A572, and ASTM A992 steel shall comply with ANSI/AWS A5.17 (tensile strength range of 70,000 psi to 95,000 psi) or ANSI/AWS A5.23 wire and flux, and shall be F7XX-EXXX or F7XX-EXX-XX.
- D. Gas-welding electrodes for steel shall comply with ANSI/AWS A5.18 (minimum yield strength of 60,000 psi).

### PART 3 EXECUTION

#### 3.01 FABRICATION

- A. Fabrication shall be in accordance with the AISC Code of Standard Practice for Steel Buildings and Bridges.
- B. Anchor Bolts:
  - 1. All anchor bolts for structural steel erection and other incidental items of the structural steel required to be built into concrete shall be properly set and securely held in position in the forms before the concrete is placed.
  - 2. Anchor bolts and setting plans for steel columns shall be provided at the site, marked or tagged for ready identification.
  - 3. Anchor bolts shall be accurately set to template and at elevation to provide suitable projection above concrete and/or grout as specified in AISC Code of Practice. Anchor bolts shall be set perpendicular to the theoretical bearing surface.
  - 4. All holes in structural steel members required for anchors, anchor bolts, bolt holes, connection angles, supports and braces for stair stringers, equipment apparatus, sag rods, or other members noted on the Contract Drawings shall be provided by the fabricator and detailed on the shop drawings.
  - 5. Where misalignment between anchor bolts and bolt holes in steel members is encountered, the Engineer shall be immediately notified. The Contractor shall submit a method to remedy the misalignment for review by the Engineer.
- C. All materials shall be properly worked and match-marked for field assembly. Where finishing is required, assembly shall be completed including bolting and welding of units before start of finishing operations.

D. Connections:

1. Unless noted otherwise on the Contract Drawings, all beam connections shall be designed for reaction values indicated on the Contract Drawings. Wherever beam reaction values or connection details are not shown, the connection shall be designed to support half the total uniform load capacity tabulated in the AISC tables for allowable loads for laterally supported beams for the given shape, span, and steel specified for the beam in question.
2. Unless noted otherwise on the Contract Drawings, all beam connections designed by the fabricator shall conform to tables for Framed Beam Connections in AISC Manual of Steel Construction.
3. Except where otherwise noted on the Contract Drawings or in this Specification, all shop connections shall be welded.

- E. Where shop assembly of field connections is shown, specified or required, the unmatched holes shall be reamed and the pieces matchmarked before disassembly. The interchange of matching parts will not be permitted.

3.02 ERECTION

- A. The erection of all structural steel shall conform to the applicable requirements of the Specifications for the Design, Fabrication and Erection of Structural Steel for Buildings of the AISC.

1. All temporary bracing, guys and bolts as may be necessary to ensure the safety of the structure until the permanent connections have been made shall be provided by the Contractor.
2. High strength steel bolts shall conform to the AISC Specifications for Structural Joints Using High-Strength Bolts.

- B. All field connections shall be accurately fitted up before being bolted. Drifting shall be only such as will bring the parts into position and shall not be sufficient to enlarge the holes or to distort the metal. All unfair holes shall be drilled or reamed.

C. High Strength Steel Bolts

1. The furnishing and installation of high-strength bolts, washers and nuts shall be in conformity with:
  - a. Relevant sections of the NYCBC.
  - b. Latest issue of Rules Relating to High-Strength Bolts by the NYCDOB.
2. All bolted connections shall use high strength bolts in bearing-type connections according to the AISC Specification for Structural Joints Using High-Strength Bolts.

3. Where indicated, high strength bolts in slip-critical connections shall be used according to AISC Specification for Structural Joints Using High-Strength Bolts. The Engineer shall approve the procedure for calibration of wrenches and installation of bolts and, in general, shall satisfy himself that all requirements of the Specifications for Structural Joints Using High-Strength Bolts are met.
- D. Cutting and Burning: The use of a gas cutting torch in the field for correcting fabrication errors will not be permitted on any major member in the structural framing. Its use may be permitted on minor members if the member is not under stress, and only after the written approval of the Engineer has been obtained.
1. No cutting of structural steel members in the field will be allowed except by written approval of the Engineer.
  2. All cutting shall be done with an oxyacetylene torch in conformity with the NYCBC and AWS.
- E. Grouting of Base Plates and Bearing Plates: All loose column base plates and billets shall be accurately set to the designated levels on steel wedges or angle screeds in preparation for grouting under this Section. Leveling plates grouted in place shall be installed under all structural steel columns.
1. Prior to the placement of non-shrink grout beneath base and bearing plates, the bottom surface of the plates shall be cleaned of all foreign materials, and concrete and masonry bearing surface shall also be cleaned of all foreign materials and roughened to improve bonding.
  2. Anchor bolts shall be tightened after the supported members have been positioned and plumbed and the non-shrink grout has attained its specified strength.
  3. Baseplates shall be grouted with non-shrink grout to assure full uniform bearing. Grouting shall be done prior to placing loads on the structure.
- F. Welding:
1. Welding, where required, shall be performed in accordance with the requirements of:
    - a. General Specification 05091 – Welding.
    - b. AWS D1.1 Structural Welding Code.
    - c. Relevant sections of the NYCBC when applicable.
  2. In assembly and during welding the component parts of built-up Work shall be held in place by sufficient clamps, temporary bolts or other adequate means to keep parts in proper position. Where temporary bolts are used, to hold the parts together in steel plates or similar work, the temporary bolts shall be removed and the holes shall be filled with

welding material where practical. Otherwise, the nuts shall be tightened and the bolt threads outside the unit shall be burned and the bolt peened to prevent the nut from loosening.

G. Misfits at Bolted Connections:

1. Where misfits in erection bolting are encountered, the Engineer shall be immediately notified. The Contractor shall submit a method to remedy the misfit for review by the Engineer. The Engineer will determine whether the remedy is acceptable or if the member must be refabricated.
2. Incorrectly sized or misaligned holes in members shall not be enlarged by burning or by the use of drift pins. The Contractor shall notify the Engineer immediately and shall submit a proposed method of remedy for review by the Engineer.

3.03 FRAME ASSEMBLY

- A. Structural frames shall be set accurately to the lines and elevations indicated on the Contract Drawings. The various members shall be aligned and adjusted to form a part of a complete frame or structure before being permanently fastened. Bearing surfaces and other surfaces which will be in permanent contact shall be cleaned before assembly. Necessary adjustments to compensate for discrepancies in elevations and alignments shall be performed.
- B. Individual members of the structure shall be leveled and plumbed within AISC tolerances. The Contractor shall provide and install all temporary bracing required until structure is complete.

3.04 PAINTING

A. General Requirements:

1. Structural steel work shall be painted in accordance with General Specification 09900 - Painting. All painting performed at the fabricator's shop shall be subject to inspection by the Engineer, and all parts of the work shall be made accessible to the Engineer.
  - a. All structural steel shall be given one prime coat before shipment to the field.
  - b. Structural steel encased in concrete shall not be painted.
  - c. Structural steel encased in masonry or which will be otherwise inaccessible in the finished work, shall receive two shop coats. After erection and before the steel is enclosed, all damaged surfaces shall be prepared and touched-up.
  - d. No paint shall be permitted on faying surfaces of slip critical joints unless it is qualified by test in accordance with AISC "Test Methods to Determine the Slip Coefficient for Coatings used in

Bolted Joints" as adopted by the Research Council on Structural connections. Manufacturer's certification shall include a certified copy of the test report.

- e. Prime coat shall be compatible with fireproofing system.
  - 2. All structural steel work specified to be painted shall be sand blasted or wheelabrated by the fabricator, of loose mill scale, loose rust, weld slag or flux deposit, dirt and other foreign matter to satisfy the following specifications of the SSPC:
    - a. SSPC SP-6, Commercial Blast Cleaning, for all steel except steel subject to immersion.
    - b. SSPC SP-10, Near-White Blast Cleaning, for steels subject to immersion.
  - 3. Cleaned steels shall be primed within 6 hours after cleaning to prevent formation of new rust.
- B. Finished Surfaces: Machine finished surfaces with zero clearance metal to metal contact shall be protected against corrosion by rust-inhibiting coating that can be easily removed prior to erection or which has characteristics that make removal unnecessary prior to erection.
- C. Field Welds: Surfaces within 2 inches of any field weld location shall be free of materials that would prevent proper welding or produce objectionable fumes while welding is being done.
- D. Defective Work: The Contractor shall correct such work as found to be defective under this Article of the Sections.
- 3.05 GALVANIZING
- A. All steel noted to be galvanized on the Contract Drawings or specified in the Detailed Specifications shall be galvanized in accordance with General Specification 05081 - Galvanizing.
  - B. All bolts and anchor bolts connecting galvanized steel members shall be galvanized.
  - C. Shop paint primer shall be omitted from steel to be galvanized.

END OF SECTION



**SECTION 05312  
Steel Roof Deck**

**PART 1 GENERAL**

**1.01 SECTION INCLUDES**

- A. The work specified in this Section consists of furnishing, fabricating and installation of cellular, non-cellular steel roof decking and appurtenant items. The work shall be completed in place as shown on the Contract Drawings and called for in the Detailed Specifications. For roof deck with concrete slab, see General Specification 05311 - Steel Floor Deck.
- B. The work shall include all incidental and miscellaneous items not specified under another Section but required for the work of this Section, whether or not specifically referred herein.
- C. Unless otherwise shown, specified or required, design, workmanship and erection shall conform to or exceed the applicable requirements of the documents listed hereinafter in Article 1.04 to the extent that the provisions of such documents are not in conflict with the requirements of this Section.
- D. This Section shall include, but shall not be limited to, the following items:
  - 1. Steel Roof Deck Units
  - 2. Acoustical Roof Deck Units
  - 3. Galvanized Finish
  - 4. Steel Closure Strips or Plates
  - 5. Steel Cover Plates
  - 6. Sheet Steel Accessories
  - 7. Ridge and Valley Plates
  - 8. Recessed Steel Roof Deck Pans
  - 9. Welding Washers
- E. The following index of this Section is presented for convenience:

<u>Article</u>	<u>Title</u>	<u>Page</u>
		05312-
PART 1	GENERAL .....	1
1.01	Section Includes .....	1
1.02	Related Section .....	2
1.03	Payment.....	2
1.04	References.....	2
1.05	Submittals .....	3

**GENERAL SPECIFICATION 05312 - STEEL ROOF DECK**

---

1.06	Quality Assurance And Qualifications .....	4
1.07	Product Delivery, Storage, And Handling .....	5
1.08	Field Measurements .....	5
PART 2	PRODUCTS.....	6
2.01	Materials .....	6
2.02	Design .....	6
2.03	Fabrication .....	7
PART 3	EXECUTION.....	8
3.01	Inspection.....	8
3.02	Installation.....	8
3.03	Galvanizing Repair .....	10
3.04	Protection .....	10
3.05	Finish Painting .....	11
1.02	RELATED SECTION	
A.	General Specification 09900 - Painting	
1.03	PAYMENT	
A.	Payment for steel roof decking shall be paid as provided for in the Detailed Specifications.	
B.	No direct payment shall be made for fastening devices required to secure the steel roof decking in place and the cost therefore shall be included in the price for steel roof decking.	
1.04	REFERENCES	
A.	ASTM A385 - Practice for Providing High Quality Zinc Coatings (Hot Dip)	
B.	ASTM A653 - Steel Sheet, Zinc-Coated (Galvanized) or Zinc-Iron Alloy-Coated (Galvannealed) by the Hot-Dip Process	
C.	ASTM A780 - Practice for Repair of Damaged and Uncoated Areas of Hot-Dip Galvanized Coatings	
D.	ASTM A924 - General Requirements for Steel Sheet, Metallic-Coated by the Hot-Dip Process	
E.	ASTM B6 - Zinc	
F.	American Galvanizers Association (AGA)	
G.	Specification for the Design of Cold-Formed Steel Structural Members (AISI)	
H.	Cold-Formed Steel Design Manual (AISI)	
I.	Design Manual for Composite Decks, Formed Decks and Roof Decks, and Cellular Metal Floor Deck with Electrical Distribution. No. 26 (SDI)	

## GENERAL SPECIFICATION 05312 - STEEL ROOF DECK

---

- J. Diaphragm Design Manual (SDI)
  - K. ANSI/AWS D1.1 Structural welding Code - Steel
  - L. ANSI/AWS D1.3 Structural Welding Code - Sheet Steel
  - M. SSPC-VIS-1 Visual Standard for Abrasive Blast Cleaned Steel (SSPC)
- 1.05 SUBMITTALS
- A. Contractor shall submit Shop Drawings and material specifications for the approval of the Engineer. Submittals shall include, but not be limited to:
    - 1. Shop Drawings: Detailed Shop Drawings which indicate for each type of steel decking required, the material, steel thickness, designation and finish, a dimensional cross-sectional profile, and computed structural properties to verify compliance with the project requirements shall be submitted. Details of fabrication and erection, including various connections, layouts of deck units placement directions, bearing on structural supports, anchorage details, attachment of accessories, each condition requiring closure panels, supplementary framing, cut opening, special jointing and other accessories as required to complete the work shall be shown on the Shop Drawings. Details and layout shall show location of supporting members, quantity and marking of decking units, size and location of holes and openings to be cut and the location, type and sequence of welded connections.
    - 2. Review of Shop Drawings will be for general considerations only. Compliance with specified requirements for materials, fabrication and erection of steel decking shall be the exclusive responsibility of the Contractor.
  - B. Certifications:
    - 1. General: Test requirements for materials as stated herein or incorporated in reference documents may be waived, provided that certified copies of test reports from approved laboratories performed on previously manufactured material are submitted.
    - 2. Manufacturer's Certifications: Manufacturer's certifications as required to show compliance with these specifications shall be submitted. Copies of mill test reports, including names and locations of mills and shops, covering the chemical and physical properties of the steel sheet to show compliance with these specifications shall be submitted. Test reports shall be accompanied by notarized certificates of compliance from the manufacturer certifying that the previously tested material is of the same type, quality and manufacture as that proposed for this project.

## GENERAL SPECIFICATION 05312 - STEEL ROOF DECK

---

3. Certification for Welders: Certification that each welder has been qualified within the previous 12 month period shall be provided in accordance with AWS D1.1.

C. Manufacturer's Data: Manufacturer's specifications and installation instructions for each type of required decking and accessory shall be submitted. These include sheet steel, steel deck units, galvanized mill finish, finished repair paint, welding electrodes, welding washers, fasteners, depressed steel roof deck pans, closure strips, cover plates, and similar items.

### 1.06 QUALITY ASSURANCE AND QUALIFICATIONS

A. Except as otherwise specified, the SDI "Design Manual" cited herein shall govern the work.

B. Qualification of Manufacturer: Steel roof deck units and accessories shall be provided where indicated on the Contract Drawings and shall be the products of a manufacturer who is regularly engaged in the manufacture of steel decking.

C. Qualification of Welders: Each welder shall be qualified in accordance with AWS D1.1. A welder shall be retested and recertified when the work of the welder creates a reasonable doubt as to his or her proficiency. Such tests when required, shall be conducted at no additional expense to the City. Recertification of the welder shall be submitted only after the welder has taken and passed the required retest.

D. Testing and Inspection: Material and fabrication procedures are subject to inspection and tests in the mill, shop and field. These tests shall be conducted by the Testing Laboratory in accordance with the requirements of General Conditions. Such inspection and tests shall not relieve the Contractor of responsibility of providing materials and fabrication procedures in compliance with specified requirements.

E. Factory Inspection: Except as specified otherwise in this paragraph, factory tests and inspections of materials will not be required provided that certified copies of factory test reports are submitted to the Engineer for approval. These shall include manufacturer's certificates of compliance with all requirements of these specifications. When the test reports are on materials previously manufactured they shall be accompanied by notarized statements from the manufacturer certifying that the materials being furnished are identical with previously manufactured materials on which the factory test reports are based.

F. Shop Drawings Reviews: Such reviews shall be obtained before custom fabrication is started and before delivery of materials to the project site.

G. Coordination: Work of this Section shall be coordinated with the work of other trades so that construction is not delayed.

## GENERAL SPECIFICATION 05312 - STEEL ROOF DECK

---

- H. Safety: Steel roof deck erection procedures and health and safety of the work force shall be the responsibility of the Contractor. The requirements of authorities having jurisdiction shall be complied with.
  - I. Responsibility for Errors: Errors of detailing and fabrication and for the correct fit of the steel deck units shall be the responsibility of the Contractor.
  - J. Remedial Action: Materials, fabrications and workmanship found defective shall be promptly removed and replaced and new acceptable work shall be provided in accordance with Contract requirements at no additional expense to the City.
  - K. Design of roof deck layout, spans, fastenings, joints, and framed openings shall be under the direct supervision of a Professional Engineer experienced in structural design of decking and licensed in the State of New York.
- 1.07 PRODUCT DELIVERY, STORAGE, AND HANDLING
- A. Delivery: Materials shall be delivered to the site in an undamaged condition and at such intervals as will avoid delay in the work.
  - B. Storage: Material shall be stored and protected in a clean, properly drained location. Material shall be kept off the ground under a weather-tight covering permitting good air circulation. Decking shall be stored on dry wood sleepers, pallets, platforms or other appropriate supports which have slope for positive drainage. Decking shall be protected from distortion, excessive stresses, corrosion and other damage.
    - 1. Caution: Materials shall not be stored on the structure in a manner that might cause distortion or damage to the supporting structure. The maximum uniform distributed storage load shall not exceed 20 pounds per square foot.
  - C. Handling: Material shall be handled safely in a manner that will prevent distortion or other damage. Care shall be exercised at all times to avoid damage through careless handling during unloading, storing and erecting.
- 1.08 FIELD MEASUREMENTS
- A. Prior to commencement of the work, existing dimensions, elevations, locations and conditions applicable to the work shall be field verified. Variances and discrepancies from the Contract Drawings and potential interferences shall be reported promptly to the Engineer.
  - B. Sufficient field measurements shall be taken prior to preparation of Shop Drawings and fabrication of construction materials, where possible, to ensure proper fitting of the work. However, job progress shall not be delayed. Allow for adjustments and fittings wherever the taking of field measurements before fabrication may not be possible or might delay the work.

- C. Actual field-verified conditions may require modifications to the fabrication and/or erection details indicated on the Contract Drawings. The work shall be performed to meet actual field conditions encountered.

## PART 2 PRODUCTS

### 2.01 MATERIALS

- A. Galvanized Steel Roof Deck: ASTM A653, Grade 33, Coating Designation G90, type and thickness as shown on Contract Drawings but not less than 20 gage.
  - 1. Galvanizing: ASTM A924, Commercial quality.
  - 2. Galvanizing Repair Paint: ASTM A780, high zinc-dust/zinc oxide content paint for repair of damaged galvanized surfaces and field touch-up of welds.
  - 3. Steel Closure Strips or Plates: ASTM A653, minimum 20 gage, galvanized (except as otherwise indicated).
  - 4. Steel Cover Plates: ASTM A653, minimum 20 gage but not less than the steel deck thickness, galvanized.
  - 5. Sheet Steel Accessories: ASTM A653, commercial quality, galvanized (thickness indicated or as suitable for use intended).
  - 6. Ridge and Valley Plates: ASTM A653, galvanized (thickness not less than that of steel deck units).
  - 7. Recessed Steel Roof Deck Pans: ASTM A653, galvanized, minimum 14 gage (0.071 inch).
- B. Acoustical Steel Roof Deck: Galvanized steel cellular deck with insulation and perforated bottom closure plate meeting the requirements of galvanized steel deck.
- C. Welding Washers: Standard type compatible with decking furnished.

### 2.02 DESIGN

- A. General: The steel deck shall be designed in accordance with AISI Specification for the Design of Cold-Formed Steel Structural Members, except as specified otherwise herein. Deck units shall have ribbed sections providing a satisfactory surface for the reception of design loads. Wherever practicable, units shall have sufficient length to span three or more supports. The depth and gage of deck shall be as specified on the Contract Drawings.
- B. Allowable Deflection: Roof deck shall be designed to support the superimposed dead load and design live load as indicated on the Contract Drawings with maximum deflection not to exceed 1/240 of the span under the following loading conditions:

## GENERAL SPECIFICATION 05312 - STEEL ROOF DECK

---

1. Uniform design live load.
  2. 200-pound concentrated load at midspan on a 1 foot wide section of deck during construction.
- C. Attachments: Roof deck units shall be installed and anchored to supporting members to provide lateral stability and resist design horizontal and uplift loadings indicated on the Contract Drawings. Fastening requirements to resist horizontal loads shall be in accordance with SDI "Diaphragm Design Manual."
- D. Section properties shall be determined in accordance with AISI "Specification for the Design of Cold-Formed Steel Structural Members." The properties of steel deck section shall be computed on the basis of the effective design width as limited by the provisions of the AISI Specifications. The section properties not less than shown on the Contract Drawings shall be provided for the specified steel deck section, including section modulus and moment of inertia per foot of width.
- 2.03 FABRICATION
- A. General: Deck units shall be manufactured in lengths to span three or more supports, where possible, with flush, telescoped or nested 2-inch end laps and nested side laps, unless otherwise indicated. End laps shall occur over supports. Deck configurations shall comply with SDI requirements and as specified herein.
- B. Metal Roof Deck:  
Galvanized Steel Roof Deck Units shall be manufactured from mill coated, extra heavy duty galvanized sheet steel conforming to ASTM A653. Configuration of roof deck units shall conform to standard SDI wide-rib fluted profile, of the depth, steel thickness or gage and section properties as indicated on the Contract Drawings.
- C. Manufacturers:  
Steel roof deck units shall be as manufactured by:
1. United Steel Deck, Inc., Summit, NJ
  2. Vulcraft Corporation, Springfield, OH.
  3. Or approved equal.
- D. Steel Closure Strips: Steel closure strips of not less than 20 gage sheet steel of the same quality and material as the deck units shall be provided and shall form to the configuration required to provide tight-fitting closures at open ends and sides of decking.
- E. Ridge and Valley Plates: Ridge and valley plates of sheet steel of the same quality and material as the deck units with each leg not less than 2-1/4 inches

## GENERAL SPECIFICATION 05312 - STEEL ROOF DECK

---

- wide shall be provided and bent to provide tight-fitting closure with deck units. Plates shall be provided in 10-foot lengths where possible.
- F. Recessed Roof Deck Pans shall be fabricated from a single piece of not less than 14 gage sheet steel of the same quality and material as the deck units, with level bottoms and sloping sides to direct water flow to the drain, unless otherwise shown on the Contract Drawings. Deck pans shall be of adequate size to receive roof drains, at least 2 feet by 2 feet, and have bearing flanges not less than 3 inches wide. Pans shall be recessed not less than 1-1/2 inches below the roof deck surface, unless otherwise shown or required by deck configuration. Holes for drains shall be cut in the field.
  - G. Painting of Deck: On the steel deck surface to be painted in the field, the galvanized surface shall be primed in accordance with the requirements of General Specification 09900 - Painting.

### PART 3 EXECUTION

#### 3.01 INSPECTION

- A. The areas and conditions under which work of this Section is to be performed shall be examined. Conditions detrimental to the proper and timely completion of the work shall be corrected. Work shall not be proceeded until satisfactory conditions have been corrected.

#### 3.02 INSTALLATION

- A. General: Deck units and accessories shall be installed in accordance with manufacturer's recommendations, approved Shop Drawings and as specified herein.
  - 1. Deck bundles shall be coordinated with structural steel erector in locating decking bundles to prevent overloading of structural members.
  - 2. Deck Storage: Deck units shall not be used for storage or working platform until permanently secured.
- B. Placing of Deck Units: Deck units shall be placed on supporting framework with edges up and flutes at right angles to supports. Decking shall be adjusted to final position with ends bearing lying at least 3 inches on supporting members. Also the decking ends shall be accurately aligned before being permanently fastened. Lap end shall not be less than 2 inches for welded construction of all roof decks. Side laps shall be one-half corrugation. The side lap interlock shall not be stretched or contracted. Deck units shall be placed flat and square, and shall be secured to adjacent framing without warp or excessive deflection and with close alignment between cells at ends of abutting deck units.



## GENERAL SPECIFICATION 05312 - STEEL ROOF DECK

---

- C. Cutting and Framing: Roof deck units and accessories shall be cut and fitted around other work projecting through or adjacent to the roof decking, as shown on the Contract Drawings. Neat, square and trim cuts shall be provided.
- D. Welding: Steel roof deck units shall be permanently fastened to steel supporting members by not less than 5/8-inch-diameter fusion (puddle) welds or elongated welds of equal strength. Welding washer shall be used where recommended by the deck manufacturer. AWS requirements and procedures for manual shielded metal-arc welding appearance, quality and methods used in correcting welding work shall be complied with. The ambient temperature when welding is performed shall be 35 degree Fahrenheit or higher. Welds shall be free of cracks, craters and other defects. Units with burned holes or any other damage shall be replaced promptly with satisfactory units at no additional cost to the City. Steel accessories shall be securely welded in place.
- E. Attachments: Steel roof deck units shall be fastened to the supporting members to resist horizontal and uplift loadings as indicated on the Contract Drawings in accordance with SDI "Diaphragm Design Manual." In no case shall the fastening requirements be less than the following:
  - 1. End Laps and Edge Supports: End laps and all edge supports shall be fastened at 6 inches on center.
  - 2. Intermediate Supports: Each sheet shall be anchored by welding at each intermediate support not less than 12 inches on center and at closer spacing where required for lateral force resistance, unless otherwise shown on the Contract Drawings.
  - 3. Side Laps: Side laps between adjacent deck units shall be locked at intervals not exceeding 18 inches on center by welding, unless otherwise shown on the Contract Drawings.
- F. Steel Closure Strips: Steel closure strips shall be provided at all open uncovered ends, at edges of roof decking and at voids between decking and other construction and shall be welded into position to provide a complete decking installation.
- G. Steel Cover Plates: Steel joint covers shall be provided at abutting ends of deck units, except where taped joints are required or permitted.
- H. Reinforcement at Openings:
  - 1. Additional steel reinforcement and closure pieces required for strength, continuity of decking, and support of other work shall be provided, unless otherwise shown or specified.
  - 2. Roof decking around openings less than 6 inches in any dimension shall be provided by means of a steel sheet of the same profile as the deck placed over the opening and fusion welded to the top surface of the deck. Steel sheet of the same quality and material as the deck units, not less

than 18 gage and at least 14 inches wider and longer than the opening shall be provided. Welds at each corner shall be provided and spaced not more than 6 inches on centers along each side.

3. Openings larger than 6 inches in steel roof deck, where framing around the opening is not shown on the Contract Drawings, shall be reinforced by steel angles on each side of the opening. The design of the framing angles shall be based on the design live load of that floor area and in no case shall the angles be less than 3-1/2 x 3-1/2 x 3/8 inches. The angles parallel to the deck span shall be connected to the structural steel framing and to the angles on the other two sides of the opening by welding. The angles shall also be anchored to the deck by welding as required for supports.

I. Roof Insulation Support: Steel closure strips shall be provided for the support of roof insulation where the rib opening in the top surface of roof decking occur adjacent to edges and opening. These strips shall be welded into position.

J. Ridge and Valley Plates: Ridge and valley plates shall be welded to the top surface of the roof decking. End joints shall be lapped not less than 3 inches with laps made in the direction of water flow.

K. Recessed Roof Deck Pans: Roof deck pans shall be placed over openings provided in the roof decking. Pans with flanges bearing on top surface of deck shall be positioned and welded to the top deck surface. Each deck flute shall be fusion welded with at least one weld at each corner. Openings in the bottom of the roof deck pan shall be cut to accommodate the drain size required.

### 3.03 GALVANIZING REPAIR

A. Decking and accessories shall be cleaned and touched-up where field cut, welded, burned or otherwise damaged. Spot repairs to galvanized or painting finish shall be made in accordance with ASTM A780 where required at no cost to the City.

### 3.04 PROTECTION

A. During installation, the steel decking shall not be used as a storage platform nor as a working platform until the deck have units been permanently fasten in position.

B. The surface of installed steel decking shall not be overloaded during the entire construction period.

C. Mechanical equipment or other loads, either temporarily or permanently, shall not be hung from steel roof decking unless otherwise detailed or permitted.

## **GENERAL SPECIFICATION 05312 - STEEL ROOF DECK**

---

### 3.05 FINISH PAINTING

- A. Exposed to view surfaces of steel roof deck units shall be field painted in accordance with the requirements of General Specification 09900 - Painting.

END OF SECTION

**GENERAL SPECIFICATION 05312 - STEEL ROOF DECK**

---

NO TEXT ON THIS PAGE

**SECTION 05400  
Cold-Formed Metal Framing**

**PART 1 GENERAL**

**1.01 SECTION INCLUDES**

- A. The Contractor shall furnish and install cold-formed metal framing as indicated on the Contract Drawings, specified in the Detailed Specifications and the requirements specified herein.
- B. The following index of this Section is included for convenience:

<u>Article</u>	<u>Title</u>	<u>Page</u>
		05400-
PART 1	GENERAL.....	1
1.01	Section Includes.....	1
1.02	Related Sections.....	1
1.03	Payment.....	1
1.04	References.....	1
1.05	Submittals.....	2
1.06	Quality Assurance.....	2
1.07	Delivery, Storage And Handling.....	3
PART 2	PRODUCTS.....	3
2.01	Materials.....	3
PART 3	EXECUTION.....	3
3.01	General.....	3
3.02	Fabrication.....	4
3.03	Installation.....	4

**1.02 RELATED SECTIONS**

- A. General Specification 05081 - Galvanizing

**1.03 PAYMENT**

- A. Cold-formed metal framing will be paid for as provided in the Detailed Specifications.

**1.04 REFERENCES**

- A. ASTM A568 - Steel, Sheet, Carbon and High-Strength, Low-Alloy Hot-Rolled and Cold-Rolled, General Requirements for.

## **GENERAL SPECIFICATION 05400 - COLD-FORMED METAL FRAMING**

---

- B. ASTM A570 - Steel Sheet and Strip, Carbon, Hot-Rolled, Structural Quality.
- C. ASTM A611 - Steel, Sheet, Carbon, Cold-Rolled, Structural Quality.
- D. ASTM A653 - Steel Sheet, Zinc-Coated (Galvanized) Zinc-Iron Alloy-Coated (Galvannealed) by the Hot-Dip Process.
- E. ASTM C645 - Nonstructural Steel Framing Members.
- F. ASTM C955 - Load-Bearing (Transverse and Axial) Steel Studs, Runners (Track), and Bracing or Bridging for Screw Application of Gypsum Panel Products and Metal Plaster Bases.
- G. AISI Specification for the Design of Cold-Formed Steel Structural Members
- H. NYBC - New York City Building Code
- I. AISI - American Iron and Steel Institute

### **1.05 SUBMITTALS**

- A. The Contractor shall submit Shop Drawings and material specifications for the approval of the Engineer. Submittals shall include, but not be limited to:
  - 1. Manufacturer's data sheets and erection instruction for each item specified.
  - 2. Layout and installation drawings for load bearing framing members showing size and gauge designations, number, type, location, and spacing.
  - 3. Drawings indicating supplemental strapping, bracing, splices, bridging, accessories, and details required for proper installation.
- B. The Contractor shall also submit samples of all framing components and fasteners.

### **1.06 QUALITY ASSURANCE**

- A. All metal framing assemblies shall be inspected and approved by the Engineer prior to application of finish materials. Assemblies not approved shall be replaced with new material.
- B. All defective, damaged or substandard quality work will be rejected and replaced with new work in accordance with the Contract Documents at no additional expense to the City.

## **GENERAL SPECIFICATION 05400 - COLD-FORMED METAL FRAMING**

---

### 1.07 DELIVERY, STORAGE AND HANDLING

- A. Protect metal framing units from rusting and damage. Deliver to project site in manufacturer's unopened containers or bundles, fully identified with name, brand, type, and grade.
- B. Store materials off ground in a dry ventilated space or protect with waterproof tarpaulins that permit the movement of water vapor, so as not to create a humidity chamber.

### PART 2 PRODUCTS

#### 2.01 MATERIALS

- A. For 16-gauge and heavier units, fabricate metal framing components of structural quality steel sheet with a minimum yield point of 40,000 psi; conforming to ASTM A570, A611 or A653.
- B. For 18-gauge and lighter units, fabricate metal framing of commercial quality steel sheet with a minimum yield point of 33,000 psi; conforming to ASTM A570, A611 or A653.
- C. Steel runners (track), blocking, lintels, clip angles, shoes, reinforcements, fasteners, and accessories shall be provided in accordance with manufacturer's recommendations for applications indicated on the Contract Drawings, and as needed to provide a complete metal framing system.
- D. Studs, tracks, etc., shall conform to ASTM C955.
- E. Galvanized finish of metal framing components shall be provided in accordance with General Specification, Section 05081 - Galvanizing and ASTM A653.
- F. Where framing units are components of assemblies indicated for a fire-resistance rating, provide units which have been approved by authorities having jurisdiction.

### PART 3 EXECUTION

#### 3.01 GENERAL

- A. The Contractor shall examine all Contract Drawings covering the work of this Section, and refer to all other Contract Drawings which may affect this work or require coordination by this trade.
- B. Execution of work of this trade constitutes acceptance of adjoining work and other conditions as being satisfactory in every respect. Later claims of defects in such cases will not constitute relief in any way from the requirement of these Specifications.

3.02 FABRICATION

- A. Framing components may be prefabricated into panels prior to erection. Fabricate panels plumb, square, true to line and braced against racking with joints welded. Perform lifting of prefabricated panels in a manner to prevent damage or distortion. Fabricate panel to a maximum allowable tolerance variation plumb, level, and true to line of 1/8 inch in 10 feet.
- B. Attach similar components by welding. Attach dissimilar components by welding, bolting or screw fasteners, as standard with manufacturer. Wire tying of framing is not permitted. Repair galvanized surfaces damaged by welding with zinc rich paint.

3.03 INSTALLATION

- A. Install metal framing system in accordance with manufacturer's printed instructions and recommendations.
- B. Install continuous tracks sized to match studs. Align tracks accurately to layout base and tops of studs. Secure tracks as recommended by stud manufacturer for type of construction involved, except do not exceed 24 inches. Provide fasteners at corners and end of track.
- C. Set studs plumb where stud system abuts columns or walls, anchor ends of stiffeners to supporting structure.
- D. Install supplementary framing, blocking, and bracing in metal framing system wherever walls or partitions are indicated to support fixtures, equipment, services, case work, heavy trim and furnishings, and similar work requiring attachment to wall or partition. Where type of supplementary support is not otherwise indicated, comply with stud manufacturer's recommendations and industry standards, considering weight or loading resulting from each item supported.
- E. Secure studs to top and bottom runner tracks by either welding or screw fastening at both inside and outside flanges.
- F. Frame openings larger than 2 feet wide with double studs at each jamb, unless more are indicated on the Contract Drawings, or indicated by manufacturer's instructions.
- G. Provide load bearing headers at each opening.
- H. Install horizontal stiffeners in stud system, spaced vertically at not more than 4-feet 6-inches on center. Weld at each intersection.
- I. Install joists level and plumb, complete with bracing and reinforcing recommended by manufacturer.

END OF SECTION



**SECTION 05501  
Metal Fabrications**

**PART 1 GENERAL**

**1.01 SECTION INCLUDES**

- A. The Contractor shall furnish, fabricate and install all metal fabrications not specifically included in other Sections and required for the completion of the work as shown on the Contract Drawings, called for in the Detailed Specifications and as specified herein.
- B. Metal fabrications shall be provided complete with all accessories, base attachments, fastenings and other appurtenances as specified and as may be required for a satisfactory installation.
- C. Unless otherwise shown, specified or required, design, workmanship and erection shall conform to or exceed the applicable requirements of the documents listed hereinafter in Article 1.04 to the extent that the provisions of such documents are not in conflict with the requirements of this Section.
- D. An index of the Articles in this Section is presented hereinafter for the convenience of the Contractor.

<u>Article</u>	<u>Title</u>	<u>Page</u>
		05501-
		1
PART 1	GENERAL .....	1
1.01	Section Includes .....	1
1.02	Related Sections.....	2
1.03	Payment.....	2
1.04	References.....	2
1.05	Submittals .....	3
1.06	Quality Assurance.....	4
1.07	Delivery, Storage And Handling.....	5
1.08	Field Measurements .....	5
PART 2	PRODUCTS.....	5
2.01	Materials .....	5
2.02	Access Stairs, Ship Ladders And Platforms .....	6
2.03	Floor Access Hatches.....	6
2.04	Galvanized Accessories .....	7
2.05	Stainless Steel Lintels And Shelf Angles.....	7
2.06	Anchor Bolts .....	7
2.07	Cast Iron Manhole Steps.....	7
2.08	Vertical Ladders.....	7
2.09	Fall Prevention System .....	8

## GENERAL SPECIFICATION 05501 - METAL FABRICATIONS

---

2.10	Stair Nosings.....	8
2.11	Steel Bollards.....	9
PART 3	EXECUTION.....	9
3.01	Inspection.....	9
3.02	Fabrication.....	9
3.03	Installation.....	10
3.04	Galvanizing.....	10
3.05	Painting.....	10
1.02	RELATED SECTIONS	
A.	General Specification 05061 - Stainless Steel Work	
B.	General Specification 05081 - Galvanizing	
C.	General Specification 05091 - Welding	
D.	General Specification 05092 - Metal Fastening	
E.	General Specification 05120 - Structural Steel	
F.	General Specification 05523 - Welded Pipe Railing (Stainless Steel)	
G.	General Specification 05533 - Aluminum Floor Gratings and Checkered Plates	
H.	General Specification 09900 - Painting	
1.03	PAYMENT	
A.	Payment for metal fabrications and appurtenances will be made as provided for in the Detailed Specifications.	
B.	No payment will be made for an item included as part of the work under another Section unless otherwise specified in the Detailed Specifications.	
C.	No separate payment will be made for appurtenances and material required to provide a complete installation, the cost thereof shall be included in the price bid for the metal fabrications.	
1.04	REFERENCES	
A.	ASTM A36 - Structural Steel.	
B.	ASTM A48 - Gray Iron Castings.	
C.	ASTM A276 - Stainless and Heat-Resisting Steel Bars and Shapes.	
D.	ASTM A480 - General Requirements for Flat-Rolled Stainless and Heat-Resisting Steel Plates, Sheet and Strips.	
E.	ASTM A666 - Austenitic Stainless Steel, Sheet, Strip Plate and Flat Bar.	

## GENERAL SPECIFICATION 05501 - METAL FABRICATIONS

---

- F. ASTM B209 - Aluminum and Aluminum-Alloy Sheet and Plate.
- G. ASTM B221 - Aluminum-Alloy Extruded Bars, Rods, Wire, Shapes and Tubes.
- H. ASTM B308 - Aluminum-Alloy 6061-T6 Standard Structural Profiles.
- I. ANSI/AWS D1.1 - Structural Welding Code.
- J. ANSI/AWS D1.2 - Structural Welding Code - Aluminum.
- K. New York City Building Code (NYBC).
- L. American Institute of Steel Construction (AISC).
- M. AISC Manual of Steel Construction.
- N. AISC Specification for Design and Fabrication of Structural Steel for Buildings Including the Commentary.
- O. Aluminum Association Specifications for Aluminum Constructions.
- P. Aluminum Company of America, "Welding and Brazing Aluminum".
- Q. Occupational Safety and Health Administration (OSHA), U.S. Department of Labor.

### 1.05 SUBMITTALS

The Contractor shall submit Shop Drawings and other materials for the approval of the Engineer. Shop drawings shall include, but not be limited to, the following:

1. Layout drawings shall indicate all structural shapes, sizes and dimensions.
  2. Certifications, schedules, design calculations, detailed drawings, plans, elevations, and details of sections and connections
  3. Detail drawings shall indicate jointing and anchoring details.
  4. Anchor bolts and setting plans
  5. Erection drawings
- B. No fabrication shall be started until Shop Drawings have been approved by the Engineer.
- C. The following shall also be submitted:
1. Manufacturer's specifications, load table, installation instructions, setting drawings and templates for location and installation of miscellaneous metal items, appurtenances and anchorage devices.
  2. Certified weld inspection reports.

## GENERAL SPECIFICATION 05501 - METAL FABRICATIONS

---

- D. The following samples shall be furnished: Representative samples of bolts, anchors and inserts as requested by the Engineer. The Engineer's review shall be for type and finish only. Compliance with all other requirements shall be the exclusive responsibility of the Contractor.
- E. Record Drawings: During progress of the work, an up to date set of drawings showing Field and Shop Drawing modifications shall be kept. Immediately upon completion of work, Record Drawings showing the actual in-place installation of all work constructed and/or installed under this Section shall be provided. Drawings shall include all necessary plans, sections and details, with all reference dimensions and elevations required for complete Record Drawings of the work.

### 1.06 QUALITY ASSURANCE

- A. Shop inspections may be made by the City's representatives. The Contractor shall give ample notice to the Engineer prior to the beginning of any fabrication work so that inspection may be provided. The Contractor shall furnish all facilities for the inspection of materials and workmanship in the shop, and the inspectors shall be allowed free access to the necessary parts of the works.
- B. Inspectors shall have the authority to reject any materials or work which does not meet the requirements of these Specifications.
- C. Inspection at the shop is intended as a means of facilitating the work and avoiding errors, but is expressly understood that it will in no way relieve the Contractor from his responsibility for furnishing proper materials or workmanship under this Section. Design of Members and Connections
  1. All details shown are typical; similar details shall apply to similar conditions, unless otherwise shown or specified. Dimensions shall be verified at the site without causing delay in the work.
  2. Each fabricator shall be responsible for the structural design of miscellaneous metal work within the requirements established by these Specifications.
- D. Complete design calculation and Shop Drawings shall be prepared, signed and stamped with the seal of a Licensed Professional Engineer, licensed to practice in the State of New York and recognized as an expert in the required work unless the design and details have been shown on the Contract Drawings.
- E. "Pencil-line" thin butt joints shall be provided.
- F. Shop Assembly: Items in the shop shall be preassembled to the greatest extent possible, so as to minimize field splicing and assembly of units at the site. Units shall be disassembled only to the extent necessary for shipping and handling limitations. Units shall be clearly marked for reassembly and coordinated installation.

## GENERAL SPECIFICATION 05501 - METAL FABRICATIONS

---

### 1.07 DELIVERY, STORAGE AND HANDLING

- A. Metal fabrications shall be handled in such a manner that they may be transported and unloaded without being over-stressed, deformed or otherwise damaged.
- B. Metal fabrications and packaged materials shall be protected from corrosion and deterioration and shall be stored in a dry area. Materials stored outdoors shall be supported above ground surfaces on wood runners and protected with effective and durable covers approved by the Engineer.
- C. Metal fabrications shall not be placed in or on a structure in a manner that might cause distortion or damage to the fabrication. The Contractor shall repair or replace damaged metal fabrications or materials as directed by the Engineer.
- D. Materials shall be delivered to the site at such intervals to insure uninterrupted progress of the work. Anchor bolts and anchorage devices, which are to be embedded in cast-in-place concrete or masonry shall be delivered, in ample time not to delay that work.

### 1.08 FIELD MEASUREMENTS

- A. The Contractor shall verify all dimensions and shall make any field measurements necessary and shall be fully responsible for accuracy and layout of the work.
- B. The Contractor shall review the Contract Drawings and any discrepancies shall be reported to the Engineer for clarification prior to starting fabrication.

## PART 2 PRODUCTS

### 2.01 MATERIALS

- A. Structural steel shapes shall be fabricated in accordance with the details shown on the Contract Drawings and shall conform to the requirements of General Specification 05120 - Structural Steel and ASTM A36 unless otherwise indicated. All steel shall be galvanized in accordance with the requirements of General Specification 05081 - Galvanizing, and shop painted in accordance with General Specification 09900 - Painting.
- B. Aluminum shapes and plate shall be 6061-T6 aluminum alloy with mill finishes, and shall be fabricated into finished products with welded or bolted connections as detailed on the Contract Drawings. Extruded shapes shall conform to the requirements of ASTM B221 and ASTM B308; plate and sheets shall conform to ASTM B209.
- C. Stainless steel shapes and plate shall be Type 316 stainless steel for bolted constructions and 316L for welded construction as detailed on the Contract Drawings and conforming to the applicable requirements of General

## GENERAL SPECIFICATION 05501 - METAL FABRICATIONS

---

Specification 05061 - Stainless Steel Work. Shapes shall conform to ASTM A276. Stainless steel plates shall conform to ASTM A480 and ASTM A666.

- D. Bolting hardware shall be as specified in General Specification 05092 - Metal Fastening.
- E. Concrete anchors shall be as specified in General Specification 05092 - Metal Fastening.

### 2.02 ACCESS STAIRS, SHIP LADDERS AND PLATFORMS

- A. Platforms, associated access stairs and ship ladders shall have galvanized steel or aluminum structural members, aluminum stair treads, and aluminum platform gratings as specified herein unless shown otherwise on the Contract Drawings.
- B. Structural steel sections shall conform to ASTM A36 and all work shall conform to the AISC Manual of Steel Construction.
- C. Aluminum platform and stair tread gratings pattern shall be as specified in General Specification 05533 - Aluminum Floor Gratings and Checkered Plates. Stair treads shall be designed to support a uniform live load of 175 pounds per square foot with a maximum deflection of 1/240 of the span. The stair treads shall have an abrasive nosing as shown on the Contract Drawings.
- D. Aluminum platform grating shall be designed for the loads as specified in the Detailed Specifications or as shown on the Contract Drawings.
- E. Stainless steel handrails shall be as specified under General Specification 05523 - Welded Pipe Railing (Stainless Steel) and shall be coordinated with stair, ship ladder and platform fabrication. Handrail attachment to stairs, ship ladders and platform shall be in accordance with the details shown on the Contract Drawings.

### 2.03 FLOOR ACCESS HATCHES

- A. Floor access hatches shall be double leaf, Type JD hatches except for openings less than 4 feet long which shall have single leaf hatches Type J. Floor access hatch shall be as manufactured by:
  - 1. The Bilco Company, Zanesville, OH.
  - 2. Or approved equal.
- B. Hatch size shall be as shown on the Contract Drawings. Hatch leaf shall be of aluminum diamond-pattern plate designed to withstand a live load as indicated on the Contract Drawings for the adjacent floor or deck area. Channel or tee type frame shall be of aluminum with an anchor flange around the perimeter and with a 1-1/2 inch drainage coupling where required.
- C. All hardware shall be of stainless steel and shall include heavy forged hinges, spring operators, an automatic hold-open arm with release handle, and a snap

lock with removable handle. The location of hinges, hold-open arm with release handle shall be as shown on the Contract Drawings and/or approved by the Engineer.

- D. Access hatches supporting floor loads shall be detailed and fabricated based on calculations indicating that they comply with New York City Building Code for the loading designated on the Contract Drawings for the adjacent floor area. If no loading is designated, a minimum design load of 300 pounds per square foot shall be used or as required for the intended use.
  - E. If the access doors are located in areas subject to vehicular traffic, they shall be designed for HS-20 loading.
- 2.04 GALVANIZED ACCESSORIES
- A. Galvanized lintel and shelf angles, angle door guards, floor curb, sill angles and guard posts (bollards), and brackets shall be fabricated from structural steel. Work shall conform to the details on the Contract Drawings and approved shop drawings. Where the material for lintels and shelf angles is not shown on the Contract Drawings, they shall conform to Article 2.05 of this Section.
  - B. Materials and fabrication shall conform to General Specification 05120 - Structural Steel and ASTM A36. All galvanizing shall be done after fabrication and shall conform to the requirements of General Specification 05081 - Galvanizing.
- 2.05 STAINLESS STEEL LINTELS AND SHELF ANGLES
- A. Lintels and shelf angles shall be bent or rolled angles, fabricated of stainless steel Type 316. All angles shall conform to the sizes, shapes, dimensions and details as noted on the Contract Drawings. The lintels assembled by welding shall be fabricated of stainless steel Type 316L.
  - B. All mounting and assembly hardware shall be Type 316 stainless steel.
- 2.06 ANCHOR BOLTS
- A. Anchor bolts shall be as specified in General Specification 05092 - Metal Fastening.
- 2.07 CAST IRON MANHOLE STEPS
- A. Manhole steps shall be made of gray cast iron conforming to ASTM A48, Class 35B. Manhole steps shall comply with OSHA 1910.27.
  - B. The steps shall be designed to be cast in place hooking behind the reinforcing steel.
- 2.08 VERTICAL LADDERS
- A. Aluminum ladders shall be fabricated from aluminum 6061-T6 as detailed on the Contract Drawings.

## GENERAL SPECIFICATION 05501 - METAL FABRICATIONS

---

- B. Stainless steel ladders shall be fabricated from Type 316L stainless steel as detailed on the Contract Drawings.
- C. Wall mounted ladders shall have welded brackets attached to the wall with concrete or masonry anchors.
- D. Ladders shall comply with OSHA 1910.27.
- E. Safety cages or fall prevention system shall be required on all ladders exceeding twenty feet height between landings.
- F. The third rail required for the fall prevention system shall be of the same material as the ladder.

### 2.09 FALL PREVENTION SYSTEM

- A. All ladders shall be provided with a fall prevention system.
- B. The fall prevention system shall be the RTC 2000 Climb-Rite System as manufactured by:
  - 1. The Research and Trading Corporation.
  - 2. Saf-T-Climb as manufactured by the Norton Company/Air Space Devices, Inc., Cerritos, California.
  - 3. Or approved equal.
- C. All necessary components shall be furnished, including two safety belts for each fall prevention installation to provide a complete and fully operational fall prevention system. Safety belts shall fit a waist range from 23 inches to 54 inches.

### 2.10 STAIR NOSINGS

- A. Provide non-slip nosings on all treads of interior stairs that are not scheduled for resilient flooring or rubber tile finishes.
- B. Non-slip nosings shall be as manufactured by one of the following manufacturers:
  - 1. Wooster Products, Inc., Wooster, OH.
  - 2. Safe-T-Metal Co., Syracuse NY.
  - 3. Or approved equal.
- C. Nosings shall be four inches wide and six inches less in length than the length of the tread.
- D. Nosings shall be installed at the edge of each tread, landing, and platform. Top of surface shall be flush with concrete finish.
- E. Each nosing shall utilize a minimum of three anchors into the concrete.
- F. Nosings shall be cast aluminum, Alloy 356-T6.



2.11 STEEL BOLLARDS

- A. Galvanized steel pipe bollards shall be fabricated to dimensions and details indicated in the Contract Drawings. Bollards shall be fabricated from 8-inch nominal outside diameter pipe, extra strong.

PART 3 EXECUTION

3.01 INSPECTION

- A. The Contractor shall examine the alignment of the substrate and conditions under which metal fabrications work is to be performed and notify the Engineer in writing of unsatisfactory conditions. Do not proceed with the metal fabrication and installation work until unsatisfactory conditions have been corrected in a manner acceptable to the Engineer.

3.02 FABRICATION

- A. Fabrication of steel and stainless steel shall be in accordance with the Specification for the Design Fabrication and Erection of Structural Steel for Building of the AISC. Fabrication of aluminum shall be in accordance with the Aluminum Association Specifications for Aluminum Structures.
- B. Holes for bolts and screws shall be drilled. Fastenings shall be concealed where practicable. Joints exposed to the weather shall be formed to exclude water.
- C. As far as practicable, all fabricated units shall be fitted and assembled in the shop, with all cuts and bends made to precision measurements in accordance with details shown on approved shop drawings.
- D. Work shall be fabricated so that it is installed in a manner that will provide for expansion and contraction, prevent the shearing of bolts, screws and other fastenings, ensure rigidity, and provide close fitting of sections.
- E. Welding of carbon and low alloy steel shall conform to the applicable requirements of ANSI/AWS D1.1, and General Specification 05091 - Welding. Welding of aluminum shall conform to the applicable recommendations of the Aluminum Company of America publication, "Welding and Brazing Aluminum"; ANSI/AWS D1.2 and Aluminum Association Specification for Aluminum Constructions. Welding shall be done in a manner that will prevent permanent buckling and all welds exposed in the finished work shall be ground smooth.
- F. All finished and/or machined faces shall be true to line and level. Steel and aluminum shall be standard, and well finished. Sections shall be well formed to shape and size with sharp lines and angles; curved work shall be sprung evenly to curves.

## GENERAL SPECIFICATION 05501 - METAL FABRICATIONS

---

- G. All work shall be fitted together at the shop as far as possible, and delivered complete and ready for erection. Proper care shall be exercised in handling all work so as not to damage the finished surfaces.

### 3.03 INSTALLATION

- A. All metal fabrications shall be erected square, plumb and true, accurately fitted, adequately anchored in place, set at proper elevations and positions.
- B. All inserts, anchor bolts and all other miscellaneous metal work specified in the Detailed Specifications or shown on the Contract Drawings or required for the proper completion of the work, which are embedded in concrete, shall be properly set and securely held in position in the forms before the concrete is placed.
- C. All miscellaneous metal fabrications shall be installed in conformance with details shown on the Contract Drawings or on the approved shop drawings.

### 3.04 GALVANIZING

- A. All miscellaneous steel fabrications shall be galvanized after fabrication in accordance with General Specification 05081 - Galvanizing.
- B. Galvanized surfaces damaged during installation shall be touched up with a galvanizing repair paint applied in accordance with the manufacturer's instructions.

### 3.05 PAINTING

- A. All miscellaneous metal fabrications other than aluminum or stainless steel, shall be painted in accordance with the requirements of General Specification 09900 - Painting.
- B. All galvanized metal fabrications shall have the surfaces exposed in the finish work painted in accordance with General Specification 09900 - Painting.
- C. Aluminum surfaces in contact with concrete or dissimilar metals shall be thoroughly protected with two coats of an epoxy paint with a total thickness of 16 mils or other approved isolating material.
- D. Surface preparation shall be done in accordance with General Specification 09900 - Painting.

END OF SECTION

**GENERAL SPECIFICATION 05533 - ALUMINUM FLOOR  
GRATINGS AND CHECKERED PLATES**

---

**SECTION 05533  
Aluminum Floor Gratings and Checkered Plates**

**PART 1 GENERAL**

**1.01 SECTION INCLUDES**

- A. The Contractor shall furnish and install all aluminum floor gratings and checkered plates as indicated on the Contract Drawings and specified herein.
- B. Gratings and checkered plates shall be complete with frames, anchors, fastening devices and miscellaneous appurtenances.
- C. The following index of this Section is presented for convenience.

<u>Article</u>	<u>Title</u>	<u>Page</u>
		05533-
PART 1	GENERAL .....	1
1.01	Section Includes .....	1
1.02	Related Sections .....	1
1.03	Payment .....	2
1.04	References .....	2
1.05	Design Requirements .....	2
1.06	Submittals .....	3
1.07	Field Measurements .....	3
PART 2	PRODUCTS .....	3
2.01	Types Of Gratings And Checkered Plates .....	3
2.02	Materials .....	4
2.03	Grating Fabrication .....	4
2.04	Grating Cut-Outs .....	5
2.05	Grating Stair Treads And Landings .....	5
2.06	Checkered Plates .....	5
2.07	Fabrication .....	5
ART 3	EXECUTION .....	6
3.01	Installation .....	6
3.02	Fastening Devices .....	6
3.03	Coating Of Contact Surfaces .....	6

**1.02 RELATED SECTIONS**

- A. General Specification 05091 - Welding.
- B. General Specification 05532 - Stainless Steel Floor Gratings and Checkered Plates
- C. General Specification 09900 - Painting.

**GENERAL SPECIFICATION 05533 - ALUMINUM FLOOR  
GRATINGS AND CHECKERED PLATES**

---

1.03 PAYMENT

- A. Payment for aluminum floor grating and checkered plate will be paid as provided for in the Detailed Specifications.
- B. No direct payment will be made for fastening devices required to secure the gratings and checkered plates in place and the cost thereof shall be included in the price for the gratings and checkered plates.

1.04 REFERENCES

- A. NAAMM MBG 533 - Welding Specifications for Fabrication of Steel, Aluminum, and Stainless Steel Bar Grating.
- B. Aluminum Association, Inc. (AA).
- C. National Association of Architectural Metal Manufacturers (NAAMM).
- D. New York City Building Code (NYBC).

1.05 DESIGN REQUIREMENTS

- A. General Design Criteria:
  - 1. The design live load for grating or plate covering floor openings shall be that designated for the adjacent floor area but not less than a uniform load of 150 pounds per square foot or a concentrated load of 300 pounds distributed over a 12-inch square area at the center of span, whichever produces the greater stress.
  - 2. The design live load for grating or checkered plate on platforms shall be as designated on the Contract Drawings but not less than a uniform load of 100 pounds per square foot.
  - 3. Grating or checkered plate in areas subject to vehicular traffic shall be designed for the maximum weight vehicle which can access the area. Forklifts or other similar wheeled vehicles shall have maximum wheel loads defined by the manufacturer. When wheel loads are not defined by the manufacturer, the wheel load shall be defined as 40 percent of the gross loaded weight of the maximum size vehicle to be accommodated. If wheel loads imposed on grating exceed 2,000 pounds, stainless steel grating per General Specification 05532 – Stainless Steel Floor Gratings and Checkered Plates shall be used. Where wheel loads imposed on stiffened checkered plate assemblies can only be supported by extending stiffeners onto the supports, contact the Engineer.
  - 4. The maximum allowable deflection due to dead load plus live load shall not exceed the span divided by 240, but not more than 1/4 inch.

**GENERAL SPECIFICATION 05533 - ALUMINUM FLOOR  
GRATINGS AND CHECKERED PLATES**

---

5. Gratings and checkered plate shall be designed in accordance with the design criteria specified herein and the Aluminum Association specifications, unless otherwise noted on the Contract Drawings or as required by the NYBC.
- B. Design Criteria for Grating: The maximum flexural stress shall be 12,000 pounds per square inch.
- C. Design Criteria for Checkered Plate:
  1. The maximum flexural stress shall be 16,000 pounds per square inch.
  2. Aluminum plate thickness shall be 1/4 inch minimum. In the event the 1/4-inch plate does not meet the specified deflection or allowable stress criteria, the plate shall be stiffened with aluminum angles or bars welded to the bottom of the plate as needed to meet the criteria. Stiffeners shall extend to within 2 inches of supports. The ends of all stiffeners shall be welded to a continuous stiffener extending the length of the plate.

1.06 SUBMITTALS

- A. The Contractor shall submit Shop Drawings and material specifications of all gratings and checkered plates for the approval of the Engineer. Submittals shall include, but not be limited to the following:
  1. Gratings and checkered plates shall not be manufactured until the Contractor's Shop Drawings have been approved by the Engineer.
  2. Samples of grating, checkered plates and fastening devices shall be submitted for approval by the Engineer.

1.07 FIELD MEASUREMENTS

- A. The Contractor shall check all dimensions in the field after all piping and equipment are set in place and determine the exact dimensions and locations of openings and cut-outs.
- B. Templates shall be made where required for location and size of openings and cut-outs.
- C. The Contractor shall field verify all pertinent dimensions prior to grating and checkered plate fabrication.

PART 2 PRODUCTS

2.01 TYPES OF GRATINGS AND CHECKERED PLATES

- A. Type of Gratings:
  1. Unless otherwise shown on the Contract Drawings or specified in the Detailed Specifications, gratings shall be one of the following types:
    - a. Swage Locked Grating.

**GENERAL SPECIFICATION 05533 - ALUMINUM FLOOR  
GRATINGS AND CHECKERED PLATES**

---

- b. Pressure Locked Grating.
- 2. Other designs of equal strength, rigidity and serviceability may be submitted to the Engineer for approval. Gratings shall be the product of one manufacturer and only one type of grating shall be used exclusively throughout the work.
- B. Types of Checkered Plates: Checkered plates, where indicated on the Contract Drawings, shall be:
  - 1. Type "F" - Fixed Cover
  - 2. Type "H" - Hinged Cover.

2.02 MATERIALS

- A. Floor gratings, checkered plates and appurtenances shall conform to the requirements specified herein and to the following aluminum alloys and tempers provided with a mill finish:
  - 1. Gratings
    - a. Main Bars - AA 6061-T6
    - b. Cross Bars - AA 6063-T5
  - 2. Angles
    - a. Extruded - AA 6063-T5
    - b. Structural - AA 6061-T6
  - 3. Anchors - AA 6061-T6
  - 4. Checkered Plates - AA 6061-T6

2.03 GRATING FABRICATION

- A. All grating sections shall be cut so that no one section will weigh more than 100 pounds.
- B. Swage Locked Grating:
  - 1. Swage locked assembly shall consist of main bearing bars, spaced not more than 1 inch apart (clear distance) joined by cross bars that are locked at right angles to, and located in the upper half of bearing bars. Cross bars shall be spaced 2 inches on center, to form rectangular openings.
- C. Pressure Locked Grating:
  - 1. Pressure locked assembly shall consist of parallel bearing bars spaced not more than 1 inch apart (clear distance) joined by cross bars spaced not more than 4 inches on centers to form rectangular openings. Cross bars and bearing bars shall be slotted for joining. Slots in the bearing

**GENERAL SPECIFICATION 05533 - ALUMINUM FLOOR  
GRATINGS AND CHECKERED PLATES**

---

bars shall terminate with dovetail recesses above the neutral axis. Slots in the cross bars shall terminate below the neutral axis. The cross bars shall be forced down into the slots of the bearing bars and their bottoms spread into the dovetail recesses to make tight rigid joints.

- D. Minimum bearing bar size shall be 1-1/2" deep by 3/16" wide.

2.04 GRATING CUT-OUTS

- A. Cut-outs shall be provided in the grating for the passage of pipe, valve stems, columns and similar work. Where more than two bearing bars are included in the cut-out, banding bars of the same dimensions as the bearing bars shall be provided around the opening and welded or electric-forged to the component parts of the grating.

2.05 GRATING STAIR TREADS AND LANDINGS

- A. Grating stair treads shall be 1 inch wider than tread widths shown on the Contract Drawings and shall be securely fastened to angles or carrier bars which in turn shall be fastened to stringers. The outer edge or nosing of stair treads shall be so constructed as to make it distinctly visible and contrasting with the other part of the tread. Non-slip nosings shall be furnished on all the stair treads and landings.

2.06 CHECKERED PLATES

- A. General:
1. Checkered plates shall have an approved, raised pattern, non-skid surface. Stiffener angles shall be provided as required to meet the loading and deflection limits specified in Article 1.05.
  2. All checkered plate sections shall be cut so that no one section will weigh more than 150 pounds. Flush type lifting handles shall be provided for all sections of checkered plates.
- B. Type "F" fixed cover checkered plates shall be furnished complete with frames, anchors, lifting handles and stainless steel flush head screw fastenings.
- C. Type "H" hinged cover checkered plates shall be furnished complete with frames, anchors, lifting handles and heavy duty concealed hinges. Hinges shall be isolated, heavy-duty, cadmium plated bronze with Type 316 stainless steel pins and fastenings. A minimum of 2 hinges shall be provided for each checkered plate section.

2.07 FABRICATION

- A. Gratings and checkered plates shall be accurately fabricated, free from warps, twists or other defects which affect the appearance and serviceability of the grating and checkered plates.

**GENERAL SPECIFICATION 05533 - ALUMINUM FLOOR  
GRATINGS AND CHECKERED PLATES**

---

- B. Gratings and checkered plates shall have a mill finish unless otherwise noted on the Contract Drawings.
- C. All welds shall be ground smooth and conform to the requirements of General Specification 05091 - Welding and NAAMM MBG 533.
- D. Openings in and edges of all grating sections shall be banded with bearing bars. Bars shall be welded to all intersecting members.
- E. For watertight and gastight checkered plate installations, provide neoprene gasket all around the perimeter and between plate sections as shown on the Contract Drawings.

**PART 3 EXECUTION**

**3.01 INSTALLATION**

- A. Gratings and checkered plates shall be installed with each section readily removable and replaceable. Adjacent units shall be neatly fitted together.
- B. The clearance at the ends or between sections of gratings and checkered plates shall be a maximum of 1/4 inch.
- C. Tops of gratings and checkered plates shall be set flush with surrounding construction.
- D. Gratings and checkered plates shall be set with a full and uniform end bearing on the supports to preclude rocking movement; wedges or similar shimming devices shall not be used.

**3.02 FASTENING DEVICES**

- A. Approved aluminum fastening devices, with stainless steel screws, shall be installed to hold the gratings rigidly to the supports with means for easy removal.
- B. Fastening devices shall not protrude above the walking surface of the grating.
- C. Fasteners shall be installed in accordance with the manufacturer's recommendations.

**3.03 COATING OF CONTACT SURFACES**

- A. Aluminum surfaces in contact with concrete or dissimilar metals shall be thoroughly protected with two coats of an epoxy paint with a total thickness of 16 mils or other approved isolating material in accordance with the requirements of General Specification 09900 - Painting.

END OF SECTION



**SECTION 06100  
Rough Carpentry**

PART 1 GENERAL

1.01 SECTION INCLUDES

- A. Rough carpentry as specified herein shall include, but not be limited to, wood centers, furring, grounds, blocking, temporary protection of all kinds, and all accessories and appurtenances.
- B. Rough carpentry shall be provided where shown on the Contract Drawings, specified in the Detailed Specifications, or as required for a complete installation.
- C. The following index of this Section is included for convenience:

<u>Article</u>	<u>Title</u>	<u>Page</u>
		06100-
PART 1	GENERAL.....	1
1.01	Section Includes.....	1
1.02	Related Section.....	1
1.03	Payment.....	1
1.04	References.....	2
1.05	Submittals.....	2
1.06	Delivery, Storage And Handling.....	3
PART 2	PRODUCTS.....	4
2.01	Materials.....	4
2.02	Accessories.....	5
PART 3	EXECUTION.....	5
3.01	Examination.....	5
3.02	Installation.....	5
3.03	Protection.....	6
3.04	Adjustment.....	6

1.02 RELATED SECTION

- A. General Specification 05081 - Galvanizing

1.03 PAYMENT

- A. No direct payment will be made for rough carpentry, accessories, or appurtenances; the cost shall be included in the prices for the Work, except as provided for in the Detailed Specifications

## GENERAL SPECIFICATION 06100 - ROUGH CARPENTRY

---

### 1.04 REFERENCES

- A. ASTM E84 - Test Method for Surface Burning Characteristics of Building Materials
- B. AWPA - American Wood Protection Association - Interior Fire Retardant Treated Lumber and Plywood
- C. NFPA - National Forest Products Association, National Design Specification for Wood Construction

### 1.05 SUBMITTALS

- A. The Contractor shall submit Shop Drawings, catalog cuts and reference materials for approval of the Engineer. Submittals shall include, but not be limited to:
  - 1. Rough Wood Carpentry: the following shall be submitted:
    - a. Copies of the chemical treatment manufacturer's instructions for proper use of each type of treated material.
    - b. For water-borne preservatives, the submittal shall include the statement that moisture content of treated materials was reduced to a maximum of 19 percent prior to shipment to project site.
    - c. Submittal shall indicate compliance with specified standards and other specified requirements for materials and workmanship.
  - 2. Wood Preservative: the following shall be submitted:
    - a. For each type specified:
      - 1) Certification shall be submitted by treating plant stating chemicals.
      - 2) Processes used.
      - 3) Net amount of salts retained.
      - 4) Conformance with applicable standards.
    - b. Submittals shall include:
      - 1) Certification by treating plant that treatment material complies with governing ordinances.
      - 2) Treatment will not bleed through finished surfaces.

3. Copies of a certificate, signed by producer, certifying that the softwood lumber producer complies with quality grades and other requirements specified. The certificate shall be submitted in a form recommended by applicable standards, written by the certifying organization.

1.06 DELIVERY, STORAGE AND HANDLING

A. Delivery of Materials:

1. Rough carpentry materials shall not be delivered to the project site before the time of installation.
2. Materials shall, however, be delivered in sufficient quantities to allow continuity of the Work.

B. Storage of Materials:

1. Materials shall be stored with manufacturers' labels and seals intact.
2. Lumber shall be stored indoors at the site on raised platforms. If outdoor storage is temporarily incorporated, material shall be set on raised platforms and covered with suitable weatherproof protective coverings, such as tarpaulins or heavy polyethylene film. Covers shall be battened down with sufficient weights, ties or anchors to prevent blowoffs.
3. Damage to materials shall be prevented during storage primarily by minimizing the amount of time they are stored at the site before being incorporated into construction systems.

C. Handling of Materials:

1. Materials shall be handled carefully in order to avoid damage or breakage.
2. Materials shall be handled in a manner which prevents inclusion of foreign materials.
3. Materials shall not be exposed to detrimental conditions or physical damage. Materials which are so exposed shall be removed from the site and shall not be incorporated into the Work.
4. Do not open packages or containers until all preparatory Work is complete and installation will begin immediately. Do not allow materials to become wet or soiled or covered with ice or snow.

**PART 2 PRODUCTS**

**2.01 MATERIALS**

- A. General: All natural wood lumber used in the Work shall be verified as obtained from a certified sustainable natural wood lumber source using sustainable forest management practices.
- B. Rough Carpentry: Lumber for rough carpentry such as nailers, grounds, blocking and framing shall be of Sustainably Managed Construction Grade, thoroughly seasoned dry No. 1 white fir, ponderosa pine, spruce or hem-fir.
- C. Preservative Treatment: All lumber for rough carpentry which is incorporated into the finished structures shall be pressure-treated lumber complying with the requirements established in the latest AWWA P5 and FS TT-W-571 standards. All lumber shall be seasoned lumber with a maximum moisture content of 19 percent at time of dressing. Water-borne preservative with 0.25 percent retainage shall generally be used, however water-borne preservative with 0.40 percent retainage shall be used for all lumber in direct contact with ground or water. All lumber shall be branded accordingly.
- D. Fire Retardant Treatment: All wood designated to be fire-retardant treated shall be pressure-impregnated with a flameproofing complying with the requirements of AWWA Type A, and with U.L., Inc. requirements for flame spread of 25 or less, with no evidence of significant progressive combustion when tested in accordance with ASTM E 84. Each piece of wood shall bear the U.L., Inc. FRS Label or the U.L., Inc. label indicating complete compliance with the fire hazard classification.
- E. Code Conformance: Materials shall conform to the requirements of the National Design Specification for Stress Grade Lumber as recommended by the National Forest Products Association, unless otherwise indicated.
- F. Plywood Standards: Plywood shall conform to the requirements of the American Plywood Association.
- G. Grading: Each panel of plywood shall be identified with the appropriate DFPA grade mark of the American Plywood Association.
- H. Exterior Plywood Uses: Exterior type plywood shall be installed where plywood is used for roof sheathing or decking, or in areas where it may be exposed to moisture.
- I. Temporary Protection: Exterior type southern yellow pine plywood, APA Grade C, plugged fir shall be used for temporary protection.

2.02 ACCESSORIES

- A. Anchors, connectors, and fastenings, not indicated or specified otherwise, shall be provided and installed and shall be of the type, size and spacing necessary to suit the conditions encountered and as recommended by National Forest Products Association. Sizes, types, and spacing of nails, screws, or bolts for installation of manufactured building materials shall be as recommended by the product manufacturer, unless indicated or specified otherwise.
  - 1. Steel rough hardware exposed to the weather shall be zinc-electroplated unless indicated otherwise. Zinc-electroplated steel bolts, nuts, washers, hangers, and straps, and all other rough hardware embedded in, or in contact with exterior walls or slabs, and located in humid areas, shall be provided and installed, except as indicated otherwise.
  - 2. Rough hardware shall be formed and punched before coating. Common steel wire nails, bright finish, shall be used, unless specified otherwise.
  - 3. Bolt heads and nuts bearing on wood shall be provided with standard steel washers.
  - 4. Galvanized fasteners for treated wood shall be in accordance with the requirements contained in General Specification 05081 - Galvanizing.

PART 3 EXECUTION

3.01 EXAMINATION

- A. The Contractor shall verify that areas to receive rough carpentry which is to be incorporated into the finished Work are properly prepared and completed to final elevations.

3.02 INSTALLATION

- A. General: Rough carpentry shall be installed in accordance with the manufacturer's recommendations and approved shop drawings.
- B. Erection: All carpentry shall be correctly laid out. All items of woodwork, hardware, and any other work in connection with carpentry shall be carefully fit and erected, accurately located, and shall be plumb, level, and properly aligned, and rigidly secured in place.
- C. Blocking: Blocking shall be furnished and installed where required for the attachment of copings, roof ventilators, ducts and other sheet metal work. Wood grounds for other work shall be provided and installed and as shown and required.

## GENERAL SPECIFICATION 06100 - ROUGH CARPENTRY

---

- D. Securing Finished Work: Wood blocks, strips, plugs and similar items shall be provided and installed as required to secure finished work to concrete and masonry.
- E. Centers: Centers shall be provided, where required, for brick and other masonry at the exterior and interior openings.
- F. Protection of other Work: Jambs of finished door frames and finished masonry openings shall be protected to a height of 6 feet above the floor. Protection shall be erected in a manner to facilitate cleaning, painting and similar work without damage to finished work.
- G. Preservative Coating: All field-cut edges and surfaces of treated lumber shall be liberally coated with a concentrated solution of preservative.

### 3.03 PROTECTION

- A. All components of the work shall be protected from detrimental weather and damage until construction operations are completed.
- B. Work which cannot be covered with complete construction systems before the onset of weather detrimental to the work shall be completely covered and protected in such a manner as to deflect water and weather from the installation without damaging adjacent work.
- C. Rough carpentry shall be protected from all damage and abuse until Final Acceptance by the City.

### 3.04 ADJUSTMENT

- A. System components which are dislodged, damaged, expanded, broken, penetrated or crushed by subsequent installation operations or by detrimental weather shall be immediately replaced with undamaged material in compliance with the Sections and properly protected as specified.

END OF SECTION

**SECTION 07111  
Bituminous Dampproofing**

**PART 1 GENERAL**

**1.01 SECTION INCLUDES**

- A. This section includes cold applied, solvent based, asphalt fibered dampproofing for concrete exterior surfaces below grade under no hydrostatic pressure.
- B. The following index of this Section is included for convenience:

<u>Article</u>	<u>Title</u>	<u>Page</u>
		07111-
PART 1	GENERAL .....	1
1.01	Section Includes .....	1
1.02	Payment.....	1
1.03	References.....	1
1.04	Submittals .....	2
1.05	Quality Assurance.....	3
1.06	Delivery, Storage And Handling.....	5
1.07	Job Conditions .....	6
1.08	Guarantees.....	7
PART 2	PRODUCTS.....	7
2.01	Materials And Manufacturers .....	7
PART 3	EXECUTION.....	8
3.01	Inspection.....	8
3.02	Substrate Preparation .....	8
3.03	Installation.....	9
3.04	Protection, Adjustment And Cleaning .....	9
3.05	Inspection And Acceptance .....	9

**1.02 PAYMENT**

- A. Payment for bituminous dampproofing shall be made as provided for in Detailed Specification.

**1.03 REFERENCES**

- A. New York City Building Code
- B. ASTM D41 - Standard Specification for Asphalt Primer Used in Roofing, Dampproofing, and Waterproofing

- C. ASTM D4479 - Standard Specification for Asphalt Roof Coatings - Asbestos free; Type 1

1.04 SUBMITTALS

- A. The Contractor shall submit Shop Drawings and Design materials for approval of the Engineer. Submittals shall include, but not be limited to:

1. Samples: Submit for approval the following:
  - a. Bituminous dampproofing system applied to a 12-inch by 12-inch by 2-inch thick concrete sample demonstrating specified surface preparation to be used on job mock-up and specified thickness of fluid-applied waterproofing. Apply waterproofing to only one-half of the sample board, leaving the other half visible and showing specified substrate preparation.
  - b. Samples will be reviewed by Engineer for general appearance and as examples of the types of components to be installed on the job mock-ups. Compliance with other requirements is the responsibility of Contractor.
2. Shop Drawings: Submit for approval the following:
  - a. Copies of specifications, installation instructions and general recommendations from the manufacturer, for each type of bituminous dampproofing product.
3. Test Reports: Submit for approval the following:
  - a. Copies of test reports verifying compliance with physical properties specified herein.
  - b. Copies of testing agencies background and experience in performing similar tests to those specified.
4. Certificates: Submit for approval the following:
  - a. Copies of certificates stating that the installer has been approved, or is a licensee of the manufacturer.
  - b. Evidence of installer's experience.
  - c. Evidence prior to delivery that materials and components furnished conform to the requirements of the Sections.
5. Statement of Application:
  - a. Upon completion of the work, submit a notarized statement to Engineer signed by Contractor stating that the work complies with the requirements of these



Specifications and the installation methods were proper and adequate for the conditions of installation and use.

1.05 QUALITY ASSURANCE

A. Source Quality Control:

1. Engage a single manufacturer who shall provide the services of a Technical Representative who shall assist Contractor and Engineer by providing technical opinions on the adequacy of materials, methods of installation and field testing methodology and significance of test results based on Shop Drawings approved by Engineer.
2. Provide such services during the time of delivery, storage, handling, job mock-up construction, installation and testing of all components.

B. Installer Qualifications:

1. Engage a single installer skilled, trained and with successful experience in the application of each product who is a licensee of the manufacturer, or who can submit evidence in writing of being acceptable to the manufacturer and who agrees to employ only tradesmen with specific skill and successful experience in this type of Work. Submit name and qualifications to Engineer along with the following information on a minimum of three successful projects:
  - a. Names and telephone numbers of owners, architects or engineers responsible for projects
  - b. Approximate contract cost of the work
  - c. Size of area installed
2. Submit proof of acceptability of installer by manufacturer to Engineer.

C. Allowable Installation Tolerances:

1. Do not install Work until substrate preparation and tolerances have been approved by Engineer, bituminous dampproofing manufacturer's Technical Representative and the bituminous dampproofing installer, and Contractor has verified to Engineer that substrates are within tolerances specified and acceptable to produce approved Work. Work advanced for any reason without such verification shall be stopped, removed and replaced with new material after substrate is approved at no additional expense to the City.

2. Substrate Tolerances:
  - a. Out-of-Plane: 1/8 inch maximum in 10 foot - 0 inches and 1/16 inch maximum in any 12 inches measured along the plane.
  - b. Maximum Offset in Plane Alignment: 1/16 inch.
  - c. Variation From Slope: 1/8 inch maximum in 10 foot - 0 inches.

D. Requirements of Regulatory Agencies:

1. Material and Equipment Acceptance Division of the Board of Standards and Appeals of New York City Department of Buildings: Where, in order to be incorporated into the Work, a particular item or product system specified by Engineer requires acceptance by the New York City Commissioner of Buildings, the Contractor shall assist the product manufacturer in obtaining such approval, without additional expense to the City, and in providing the City with an approved certified copy of the boards resolution giving the MEA number for the item or product system which shall be submitted to Engineer as part of the Working Drawing approval process. Contractor may submit, in place of products specified by Engineer, products which are "equal" in all ways to the product specified but which have already achieved an MEA number. Such "or approved equal" product submissions shall not change the requirements of these Sections as to performance, required features or properties, as determined by Engineer, and shall not require additional compensation to Contractor or additional expense to the City. Final acceptance of "equal" is at the sole determination of Engineer.
2. Comply with all applicable requirements of governing authorities and codes for all Work.
3. In those instances where the Commissioner of Buildings requires a certificate of compliance of the manufacturer or producer certifying that the item or product system was tested and is equivalent to material of the same kind and quality regularly being manufactured by such manufacturer or producer Contractor shall provide all such certificates to the Commissioner of Buildings without additional expense to the City.

E. Job Mock-Ups:

1. Prior to the installation of bituminous dampproofing, but after Engineer's approval of Working Drawing submittals, erect stepped-back job mock-ups using substrate preparation, materials and application techniques specified and approved for final Work. Provide all components of the bituminous dampproofing showing the correct installation, substrate preparation and the workmanship quality which shall be achieved in the Work. Build mock-ups at the site, in location approved by Engineer, of full thickness and approximately 4 feet long and 4 feet square. Indicate the proposed workmanship to be expected in the finished Work. Obtain Engineer's acceptance of mock-ups before start of Work. Retain and protect mock-ups before start of Work. Retain and protect mock-ups during construction as a standard of judging completed Work. Do not alter or destroy mock-ups until given written permission by Engineer.
2. Build as many job mock-ups as necessary in order to achieve Engineer's acceptance of the Work.
3. Work which proceeds without approved job mock-ups shall be stopped, removed and re-installed, after job mock-up approval, at no additional expense to the City.

1.06 DELIVERY, STORAGE AND HANDLING

A. Delivery of Materials:

1. Deliver materials in manufacturer's original, unopened and undamaged containers, with information accurately representing container contents as approved by Engineer at time of Working Drawing submission.
2. Include the following information on the label:
  - a. Name of material and supplier.
  - b. Installation, handling and protection requirements.
3. Deliver materials in sufficient quantities to allow uninterrupted continuity of the Work.

B. Storage of Materials:

1. Store materials in original, undamaged containers with manufacturer's labels and seals intact.
2. Store all materials in a dry, enclosed area, off the ground and away from all possible contact with water and in a location where temperature can be constantly maintained between 60 F and 75 F and out of direct sunlight.

3. Prevent damage to materials during storage primarily by minimizing the amount of time they are stored at the site before being incorporated into construction systems.

C. Handling of Materials:

1. Do not open containers, or expose materials to detrimental conditions or physical damage. Materials which are so exposed shall be removed from the site and shall not be incorporated into the Work.
2. Handle materials in a manner which prevents contamination and inclusion of foreign materials.
3. Do not open packages or containers until all necessary preparatory Work is complete, approved and installation will begin immediately. Do not allow materials to become wet or soiled or covered with ice or snow.

1.07 JOB CONDITIONS

A. Environmental Conditions:

1. Proceed with Work only when temperature and moisture conditions comply with the manufacturer's written recommendations and when no rain or other damaging environmental condition is forecast for the time when the materials will be exposed to potential damage.
2. Protect Work from precipitation, frost and direct sun. Erect temporary shelters to protect Work in progress.
3. Proceed with bituminous dampproofing only when weather conditions will permit unrestricted use of materials and quality control of the Work being installed, complying with the Sections and with the recommendations of the bituminous dampproofing manufacturer, and only when manufacturer and installer are willing to guarantee the Work as required without additional reservations and restrictions.
4. Record decisions, conditions and agreements to proceed with the Work when weather conditions might be unfavorable. State the reasons for proceeding, with the names of the persons involved along with the changes, if any, or revisions, requirements or terms of the Contract.

B. Protection:

1. Provide continuous protection of materials against damage, wetting and moisture absorption primarily by storing materials

under cover and above ground and away from other construction traffic.

2. Protect installed materials and completed systems against damage by construction activities. Exclude all persons not involved with the Work from the work area until such time as the Work has been isolated from all potential damage.

C. Substitutions:

1. Do not change products, system components, installation techniques or manufacturers after Working Drawing approval by Engineer.
2. Clearly identify, in a manner which is highlighted to Engineer, all proposed substitutions, modifications, variations, unspecified features and "or equal" products. Provide complete comparative data with specified products at time of Working Drawing submission.

1.08 GUARANTEES

- A. Guarantee that all Work performed under this Section is free from defects in material and workmanship and conforms to all standards in the manufacturers published data sheets. Contractor shall warrant its bituminous dampproofing work for a period of two years from the date of Final Acceptance of the Work.
- B. In addition, the manufacturer of the bituminous dampproofing shall provide the City with a five year guarantee warranting the Work watertight and free from defects in material, abnormal aging, workmanship, and arrangement of the various parts. Comply with all requirements of the manufacturer in order to provide guaranteed construction.

PART 2 PRODUCTS

2.01 MATERIALS AND MANUFACTURERS

- A. Fibered dampproofing, type "83AF" as manufactured by:
  1. Karnak Corp., Clark, NJ.
  2. Or approved equal,  
complying with the following:
    - a. Solids by Weight: 72%
    - b. Solids by Volume: 65%
    - c. Permeability: 0.003

- d. ASTM D4479 - Type 1
  - e. Cure Time: 24 to 48 hours @ 70°F, 50% RH
- B. Asphalt Primer, Type "108" as manufactured by:
- 1. Karnak Corp., Clark, NJ.
  - 2. Or approved equal,  
conforming to the following:
    - a. ASTM D41
    - b. Fed Spec #SS-A-701
    - c. AASHTO M-116

### PART 3 EXECUTION

#### 3.01 INSPECTION

- A. The Contractor shall examine the surfaces to receive the dampproofing, and the conditions under which the Work is to be performed, and notify Engineer in writing of all conditions detrimental to the proper and timely completion of the Work and the performance of the dampproofing systems. Do not proceed with the dampproofing Work until unsatisfactory conditions have been corrected in a manner acceptable to Engineer.

#### 3.02 SUBSTRATE PREPARATION

- A. Provide cast-in-place concrete free from voids and sharp projections before placing any fluid-applied waterproofing system. Comply with the manufacturer's instructions for the preparation of the substrates to receive the dampproofing system unless more stringent conditions are specified.
- B. Remove surface irregularities on cast-in-place concrete and fill all holes, honeycombs, spalls and cracks using manufacturer's recommended joint seal parging. Repair areas of unacceptable consolidation. Where necessary to remove sharp projections, grind concrete surfaces.
- C. Clean the substrate of dust, debris and other substances detrimental to the Work. Remove grease, oil and other contaminants from surfaces of cast-in-place concrete.
- D. Parge all construction joints to a minimum depth of 1/8 inch and 3 inch minimum width using manufacturer's recommended joint seal parging.
- E. Seal all through-wall projections using elastic sheet flashing and manufacturer's recommended sealants.

- F. Prime the substrate with a seal coat as recommended by the manufacturer.

3.03 INSTALLATION

- A. Comply with manufacturer's instructions for the installation of bituminous dampproofing.
  - 1. Concrete substrate walls shall be cured for a minimum of 30 days prior to installation of dampproofing system.
  - 2. All cracks and non-working joints over 1/8 inch shall be filled using trowel grade material of the specified system.
  - 3. Asphalt primer shall be installed with a wide fiber brush at the rate of 1 gallon per 100 square feet.
  - 4. Fibered dampproofing shall be installed with a wide fiber brush at the rate of 4 gallons per 100 square feet.
  - 5. Dampproofing shall be cured for a minimum of 48 hours before backfilling.
  - 6. Install 1/8 inch thick protection board, approved by the manufacturer, before backfilling.

3.04 PROTECTION, ADJUSTMENT AND CLEANING

- A. Protect the area from access by other installers and Contractors until the Work of this Section has been incorporated into finished construction systems.
- B. Protect other Work from spillage of dampproofing materials, and prevent materials from entering and clogging drains and conductors. Replace or restore other Work which is soiled or otherwise damaged by the performance of the dampproofing and associated work.
- C. System components which are dislodged, damaged, or penetrated by subsequent installation operations or damaged by detrimental conditions shall be immediately replaced with undamaged material in compliance with the Sections and properly protected as specified.

3.05 INSPECTION AND ACCEPTANCE

- A. Certify that the completed bituminous dampproofing Work is in accordance with the Sections and is waterproof, of uniform thickness and without gaps, holidays or pinholes at the time of Final Acceptance.

END OF SECTION

**GENERAL SPECIFICATION 07111 - BITUMINOUS DAMPPROOFING**

---

NO TEXT ON THIS PAGE



**SECTION 07210  
Building Insulation**

**PART 1 GENERAL**

**1.01 SUMMARY**

- A. This Section describes the requirements for perimeter foundation insulation, cavity wall insulation, formaldehyde-free recycled glass fiber thermal batt insulation, ultra lightweight foamed-in-place cementitious insulation, preformed concrete masonry unit core insulation, loose fill insulation, fire safing insulation with gas and smoke tight fire-resistant sealants and other fire stop system components for each kind and condition of penetration through fire-rated construction and miscellaneous materials and accessories as specified herein and as required to complete the Work.
- B. The Contractor shall provide all labor, materials, equipment and incidentals as shown, specified and required to furnish and install all building insulation Work.
- C. The Contractor shall implement practices and procedures to meet the project's sustainability goals as identified in the Contract Documents. The Contractor shall ensure that the sustainability requirements of this Section are implemented to the fullest extent.
- D. The following index of this Section is presented for convenience:

<u>Article</u>	<u>Title</u>	<u>Page</u>
		07210-
PART 1	GENERAL .....	1
1.01	Summary .....	1
1.02	Payment.....	2
1.03	References.....	2
1.04	System Design Requirements .....	3
1.05	Quality Assurance.....	4
1.06	Submittals .....	6
1.07	Delivery, Storage And Handling.....	7
1.08	Project Conditions.....	8
PART 2	PRODUCTS.....	9
2.01	Materials And Manufacturers .....	9
2.02	Mixing.....	15
PART 3	EXECUTION.....	15
3.01	Examination .....	15

## GENERAL SPECIFICATION 07210 - BUILDING INSULATION

---

3.02	Substrate Preparation .....	15
3.03	Installation.....	15
3.04	Protection .....	18
3.05	Field Quality Control .....	18
3.06	Adjustment And Cleaning.....	19
3.07	Inspection And Acceptance .....	19
1.02	PAYMENT	
A.	No separate payment will be made for performing any work of this Section and all costs associated thereof shall be included in the lump sum price bid for the Contract, except as provided for in the Detailed Specifications.	
1.03	REFERENCES	
A.	NYCBC -- New York City Building Code	
B.	ASTM C177 -- Steady-State Heat Flux Measurement and Thermal Transmission Properties by Means of the Guarded-Hot-Plate Apparatus, Standard Test Method for	
C.	ASTM C203 -- Breaking Load and Flexural Properties of Block-Type Thermal Insulation, Standard Test Methods for	
D.	ASTM C236 -- Steady-State Thermal Performance of Building Assemblies by Means of a Guarded Hot Box, Test Method for	
E.	ASTM C272 -- Water Absorption of Core Materials for Structural Sandwich Constructions, Test Method for	
F.	ASTM C303 -- Dimensions and Density of Preformed Block-Type Thermal Insulation, Test Method for	
G.	ASTM C518 -- Steady-State Heat Flux Measurements and Thermal Transmission Properties by Means of Heat Flow Meter Apparatus, Test Method for	
H.	ASTM C520 -- Density of Granular Loose Fill Insulation, Test Method for	
I.	ASTM C531 -- Linear Shrinkage and Coefficient of Thermal Expansion of Chemical-Resistant Mortars, Monolithic Surfacing, and Polymer Concrete, Test Method for	

## **GENERAL SPECIFICATION 07210 - BUILDING INSULATION**

---

- J. ASTM C549 -- Perlite Loose Fill Insulation, Specification for
- K. ASTM C578 -- Rigid, Cellular Polystyrene Thermal Insulation, Specification for
- L. ASTM C665 -- Mineral-Fiber Blanket Thermal Insulation for Light Frame Construction and Manufactured Housing, Specification for
- M. ASTM D449 -- Asphalt Used in Dampproofing and Waterproofing, Specifications for
- N. ASTM D696 -- Coefficient of Linear Thermal Expansion of Plastics between -30 Degrees C and 30 Degrees C, Test Method for
- O. ASTM D1621 -- Compressive Properties of Rigid Cellular Plastics, Test Method for
- P. ASTM E84 -- Surface Burning Characteristics of Building Materials, Test Method for
- Q. ASTM E96 -- Water Vapor Transmission of Materials, Test Method for
- R. ASTM E119 -- Fire Tests of Building Construction and Materials, Test Methods for
- S. UL 1479 -- Fire Tests of Through-Penetration Firestops

### 1.04 SYSTEM DESIGN REQUIREMENTS

#### A. Substitutions:

1. Do not change products, system components, manufacturers after Shop Drawing approval by Engineer.
2. Clearly identify, in a manner which is highlighted to Engineer, all proposed substitutions, modifications, variations, unspecified features and "or equal" products. Provide complete comparative data with specified products at time of Shop Drawing submission.

- B. Project-specific system design requirements will be provided in the Detailed Specifications, if necessary, to supplement requirements given herein or on the Contract Drawings.

1.05 QUALITY ASSURANCE

A. Manufacturer/Installer Qualifications:

1. Obtain all foamed-in-place cementitious insulation from a manufacturer who is a licensed manufacturer of the product developer and who will also be responsible for the installation of foamed-in-place cementitious insulation.
2. Engage single installers for each type of building insulation who are skilled, trained and have a record of successful experience in the application of each product and who have a record of performing Work in accordance with the recommendations and requirements of the manufacturer or who can submit evidence in writing of being acceptable to the manufacturer for production of guaranteed construction and who agrees to employ only tradesmen with specific skill and successful experience in each type of Work. Submit names and qualifications to Engineer along with the following information on a minimum of three successful projects:
  - a. Names and telephone numbers of owners, architects or engineers responsible for projects.
  - b. Approximate contract cost of the building insulation system installed.
  - c. Amount of area installed.

B. Source Quality Control:

1. Obtain building insulations, requiring a hydrochlorofluorocarbon blowing agent, from manufacturers who manufacture specified insulation using a blowing agent acceptable for use until the year 2020 complying with the requirements of the Copenhagen Amendments to the Montreal Protocol in all ways.
2. Provide a manufacturer who will provide complete technical services including preparation and review of Shop Drawings, installation methods and proposed detailing for the Work.

C. Performance Criteria:

1. Thermal Conductivity: The thicknesses shown are for the thermal conductivity, k-value at 75 degrees F, specified for each material.
2. Provide adjusted thicknesses as directed by Engineer for the use of material having a different thermal conductivity.

D. Materials and Equipment Compliance:

1. Materials and equipment submitted for DEP's approval by the Contractor shall have met, at the time of their submittal, the certification and material acceptance requirements of the NYC Department of Buildings, unless otherwise required by the Authority Having Jurisdiction over the Work.
2. All material provided under this Section shall comply with the Detailed Specifications.
3. Comply with all applicable requirements of governing authorities and codes for all Work.

E. Pre-installation Conference:

1. Prior to the installation of the foamed-in-place cementitious insulation and associated Work, Contractor shall schedule and meet at the site with the installer of the foamed-in-place cementitious insulation, sheet metal cladding installer, the installer of each component of associated work, Engineer and other representatives directly concerned with performance of the Work. Review foreseeable methods and procedures related to the foamed-in-place cementitious insulation Work, including but not necessarily limited to, the following:
  - a. Review project requirements, including Drawings, Sections and other Contract Documents.
  - b. Review required submittals, both completed and yet to be completed.
  - c. Review status of substrates including curing of foamed-in-place insulation, structural loading limitations and similar considerations.
  - d. Review availability of materials, tradesmen, equipment and facilities needed to make progress and avoid delays.
  - e. Review required inspection, testing, certifying and accounting procedures.
  - f. Review weather and forecasted weather conditions, and procedures for coping with unfavorable conditions.
  - g. Review regulations concerning environmental protection, health, safety, fire and similar considerations.
  - h. Review procedures needed for protection of substrates during the remainder of the stainless steel cladding construction period.

2. Reconvene the meeting at the earliest opportunity if additional information must be developed in order to conclude the subjects under consideration.
3. Record any revisions or changes agreed upon, reasons therefor, and parties agreeing or disagreeing with them.

1.06 SUBMITTALS

A. Contractor shall submit Shop Drawings for approval of the Engineer. Submittals shall include, but not be limited, to:

1. Samples: Submit for approval the following:
  - a. 12-inch by 12-inch sample of each insulation product and each accessory and miscellaneous material to be used in the Work.
  - b. Samples will be reviewed by Engineer for general appearance and as examples of the types of components to be installed on the job mock-ups specified in other Sections. Compliance with other requirements is the responsibility of Contractor.
2. Shop Drawings: Submit for approval the following:
  - a. Copies of specifications, installation instructions and general recommendations from the building insulation manufacturers, for each type of building insulation product. Include manufacturer's data substantiating that the materials comply with the requirements.
  - b. Complete selection of fire stop manufacturer's recommended systems for each condition and kind of penetration encountered in the Work. Coordinate with equipment manufacturers for required number and kind of penetrations through fire rated construction. Provide a schedule of penetrations and the fire stop system to be included in the Work for each condition and kind of penetration encountered.
  - c. Drawings showing extent of the Work and all details required for the Work referencing system components provided as samples to Engineer.
3. Test Reports: Submit for approval the following:
  - a. Copies of test reports verifying compliance with physical properties and environmental features specified herein.

- b. Copies of testing agencies background and experience in performing similar tests to those specified.
- 4. Certificates: Submit for approval copies of certificates stating that the manufacturer of the foam-type rigid board insulation has used an environmentally safe blowing agent complying with the requirements of the Sections.

1.07 DELIVERY, STORAGE AND HANDLING

A. Delivery of Materials:

- 1. Deliver building insulation products in manufacturer's original, unopened, factory-sealed containers, bearing manufacturer's name and labels, accurately representing container contents as approved by Engineer at time of Shop Drawing submission.
- 2. Damaged materials unsuitable for use shall be rejected by Engineer and permanently removed from site by Contractor.
- 3. Do not deliver insulation materials to the project site before the time of installation.
- 4. Deliver materials in sufficient quantities to allow uninterrupted continuity of the Work.

B. Storage of Materials:

- 1. Store materials in original, undamaged containers with manufacturer's labels and seals intact.
- 2. Store all materials in a dry, enclosed area, off the ground and away from all possible contact with water, ice or snow.
- 3. Prevent damage to materials during storage primarily by minimizing the amount of time they are stored at the job-site before being incorporated into construction systems.

C. Handling of Materials:

- 1. Handle materials carefully in order to avoid damage and breakage or compressing of boards to less than their specified thickness or other damage.
- 2. Do not open containers, or expose materials to detrimental conditions or physical damage. Materials which are so exposed shall be removed from the Site and shall not be incorporated into the Work.
- 3. Handle materials in a manner which prevents inclusion of foreign materials.

4. Do not open packages or containers until all necessary preparatory Work is complete and installation will begin immediately. Do not allow materials to become wet or soiled or covered with ice or snow.

1.08 PROJECT CONDITIONS

A. Environmental Conditions:

1. Do not install building insulation when weather conditions are such that conditions do not comply with the building insulations manufacturer's written recommendations. Install building insulations only when damaging environmental condition are not forecasted for the time when the system material components will be exposed to potential damage.
2. Install foamed-in-place cementitious insulation only when the combination of interior and exterior temperatures are such that the temperature at the point of application is 40°F and rising during the application process and 48 hour initial curing period.
3. If Contractor wishes to advance the foamed-in-place cementitious insulation Work when weather conditions are not within manufacturer's recommended temperature ranges provide enclosures with heat to maintain manufacturer's recommended temperatures during the initial curing period. Erecting and maintaining all such enclosures and the provision of heat and heating equipment shall be at no additional expense to the City.
4. Protect Work from precipitation, frost and direct sun.
5. Record decisions, conditions and agreements to proceed with the Work when weather conditions might be unfavorable. State the reasons for proceeding, with the names of the persons involved along with the changes, if any, or revisions, requirements or terms of the Contract.
6. Proceed with the Work only when temperature and moisture conditions comply with the manufacturer's written recommendations.

B. Protection:

1. Do not overload the building structure or damage in-place construction system with the weight of stored materials or use of equipment.
2. Provide continuous protection of materials against damage, wetting and moisture absorption primarily by storing materials



under cover and above ground and away from all other construction traffic.

3. Protect materials against damage by construction activities.

C. Scheduling:

1. Proceed with the building insulation and associated Work only after curbs, blocking, OSB substrate board, nailer strips, vents, drains and other projections through the substrates have been installed, and when the substrate construction and framing of openings is complete.
2. Proceed with and complete the Work only when materials, equipment and tradesmen required for the installation of the building insulation and backfilling operations are at the site and are ready to follow with the Work in a manner which will not leave the Work vulnerable to damage or deterioration.
3. Do not advance the installation of building insulation materials beyond that which is necessary for proper sequencing of the Work and for which there is proper and secure protection from damaging weather and construction activities.
4. Do not begin stainless steel sheet metal cladding until testing confirms that all cavity spaces between the structure and OSB sheet metal substrate sheathing have been completely and uniformly filled with foamed-in-place cementitious insulation. Do not delay job progress or permit OSB substrate to degrade with exposure to detrimental weather conditions. Schedule installation of sheet metal cladding immediately after testing indicates that all cavities have been filled or after remedial foamed-in-place cementitious insulation Work has been completed. No final payment shall be made until testing confirms acceptability of the foamed-in-place cementitious insulation installation and acceptability of the OSB substrate by the sheet metal cladding manufacturer.

PART 2 PRODUCTS

2.01 MATERIALS AND MANUFACTURERS

A. Perimeter Foundation Insulations: Provide the following:

1. Rigid, closed-cell, thermally stabilized, very high-load-resisting, extruded, hydrogenated chlorofluorocarbon blown, foam board insulation consisting of 100 percent virgin extruded polystyrene modified resin complying with ASTM C578, Type V.

## GENERAL SPECIFICATION 07210 - BUILDING INSULATION

---

2. Provide a blowing agent with lowest available ozone depletion potential, such as HCFC-142b, or better. HCFC-141b shall not be approved by Engineer.
  3. Physical Properties: Provide the following:
    - a. Thermal Conductivity (k), ASTM C177 and ASTM C518: 0.20 Btu/in./hr./sf/°F.
    - b. Compressive Strength (psi at 5% deformation) ASTM D1621: 100 psi minimum.
    - c. Flexural Strength, ASTM C203: 100 psi minimum.
    - d. Coefficient of Thermal Expansion, ASTM D696:  $3.5 \times 10^{-5}$  inches/in./F.
    - e. Water Vapor Absorption, ASTM C272: Less than 0.1% by volume maximum.
    - f. Water Vapor Permeance, ASTM E96: 0.3-0.8 perms/inch maximum.
    - g. Flame Spread, ASTM E84: 5.
    - h. Smoke Developed, ASTM E84: 165 maximum.
  4. Thickness: Two layers each 2-inches thick.
  5. Width: 24-inches
  6. Length: 96-inches
  7. Product and Manufacturer: Provide one of the following:
    - a. STYROFOAM 100 HIGH LOAD as manufactured by:
      - 1) The Dow Chemical Company, Midland, MI.
      - 2) Or approved equal.
- B. Cavity Wall Rigid Insulation Board: Provide the following:
1. Rigid, rectangular boards of extruded polystyrene complying with ASTM C578, Type X and IV.
  2. Provide a blowing agent with lowest available ozone depletion potential, such as HCFC-142b, or better. HCFC-141b shall not be approved by Engineer.
  3. Physical Properties: Provide the following:
    - a. Minimum Compressive Strength, (at 10 percent deformation), ASTM D1621: 25 psi.
    - b. Flame Spread, ASTM E84: 10 maximum

## GENERAL SPECIFICATION 07210 - BUILDING INSULATION

---

- c. Smoke Development, ASTM E84: 165 maximum
  - d. Vapor Transmission, ASTM E96: 0.4 - 1.1 perms/inch
  - e. Thermal Resistance, ASTM C177: 5/inch and 5.6/inch
  - f. Maximum Water Absorption, ASTM C272: 0.10% by volume
4. Size: 24-inches by 96 inches by 2-inches thick and 16-inches by 96-inches by 2-inches thick.
  5. Product and Manufacturer: Provide one of the following:
    - a. CAVITYMATE ULTRA and Square Edge STYROFOAM, as manufactured by:
      - 1) The Dow Chemical Company, Midland, MI.
      - 2) Or approved equal.
- C. Foamed-In-Place Cementitious Insulation: Provide the following:
1. Provide an ultra lightweight, non-corrosive, insulating foam, which will not shrink or settle and recommended by the manufacturer for high temperature installations, foamed to a density of 2.07 pounds per cubic foot minimum, and consisting of a combination of inorganic cementitious stabilizer, a microscopic cell generator, a catalyst, and compressed air.
  2. Environmental Profile: Provide a foamed-in-place cementitious insulation free of hydrochlorofluorocarbon blowing agents, mineral fibers, asbestos, formaldehyde and which is 98 percent inorganic and which contributes no harmful gases under flaming and smoldering conditions and is non-hazardous as waste material.
  3. Physical Properties: Provide the following:
    - a. Dimensional Stability, ASTM C531: Shrinkage: 0.
    - b. Flame Spread, ASTM E84: 0.
    - c. Smoke Developed, ASTM E84: 0.
    - d. Fuel Contributed, ASTM E84: 0.
    - e. Thermal Conductivity (k), ASTM C518: 0.257.
  4. Product and Manufacturer: Provide one of the following:
    - a. 'Airkrete' cementitious foam insulation as manufactured by:
    - b. AirKrete Incorporated, Weedsport, NY.

- c. Or approved equal.
- D. Recycled Glass Fiber Insulation Batts: Provide the following:
- 1. General: Provide unfaced, polyethylene encapsulated insulation formed from glass fibers certified by SCS as containing a minimum of 25 percent total recycle glass content with a minimum of 18 percent obtained from post-consumer recycled bottle glass and thermosetting acrylic resin binders fabricated into flexible blankets, complying with ASTM C665, Type 1.
  - 2. Physical Properties: Provide the following:
    - a. Thermal Conductivity (k), ASTM C518: 0.32.
    - b. Btu/in./hr./sf/EF.
    - c. Density, ASTM C303: 1.5 pcf.
    - d. Water Vapor Transmission, ASTM E96: 0.10 perm/inch.
    - e. Flame Spread, ASTM E84: 25.
    - f. Smoke Developed, ASTM E84: 50.
  - 3. Thickness: 6-3/4-inches
  - 4. Nominal Width: 24-inches by 48-inches
  - 5. Product and Manufacturer: Provide one of the following:
    - a. Grid-SHIELD Thermal Batt Insulation as manufactured by:
      - 1) Schuller International, Incorporated ((Johns-Manville), Littleton), CO.
      - 2) Or approved equal.
- E. Preformed Concrete Masonry Unit Core Insulation: Provide the following:
- 1. Individually molded expanded polystyrene core insulation complying with ASTM C236, and ASTM C578 Standard Type I.
  - 2. Physical Properties: Provide the following:
    - a. Density, ASTM C303: 0.90-1.14 pounds per cubic foot minimum.
    - b. Water Vapor Transmission, ASTM E96: 1.4 per inch
    - c. Thermal Conductivity (k), ASTM C177: 0.26 BTU/in/hr/sf<sup>0</sup>F.

## GENERAL SPECIFICATION 07210 - BUILDING INSULATION

---

- d. Compressive Strength, ASTM D1621: 10-13 pounds per square inch.
  - e. Flame Spread, ASTM E84: 5 maximum.
  - f. Smoke Developed, ASTM E84: 130 maximum.
3. Product and Manufacturer: Provide one of the following:
- a. Korfil Standard U-Shaped Block Insulation as manufactured by:
    - 1) Concrete Block Insulating Systems Incorporated, a Division of W.R. Grace Construction Products, Incorporated, West Brookfield, MA.
    - 2) Or approved equal.
  - b. Blocfil as manufactured by:
    - 1) Blocfil Company, Division of Patek Investment Corporation, Portland, CT.
    - 2) Or approved equal.
- F. Loose Granular Perlite Insulation: Provide the following:
- 1. Loose Fill Insulation: Provide inert asbestos-free volcanic glass-like perlite aggregates expanded by a special heat process and treated with non-flammable silicone complying with FS HH-I-515D and FS HH-I-574B.
  - 2. Physical Properties: Provide the following:
    - a. Thermal Conductivity (k), ASTM C549: 0.37
    - b. Btu/in/hr/sf/EF.
    - c. Density, ASTM C520: 5-8 pounds per cubic foot.
    - d. Flame Spread, ASTM E84: 0.
    - e. Fuel Contributed, ASTM E84: 0.
    - f. Smoke Development, ASTM E84: 0.
  - 3. Product and Manufacturer: Provide one of the following:
    - a. Permalite as manufactured by:
      - 1) Grefco Incorporated, Torrance, CA.
      - 2) Or approved equal.
- G. Fire Safing Insulation: Provide the following:

## GENERAL SPECIFICATION 07210 - BUILDING INSULATION

---

1. Mineral Fiber Insulation: Unfaced, semi-rigid, non-asbestos, non-combustible blankets composed of compounds of spun mineral fiber felt, complying with ASTM C665, Type I, and FS HH-I-558B, Type 1 and 2.
  2. Physical Properties: Provide the following:
    - a. Thermal Conductivity (k), ASTM C518: 0.25 Btu/in./hr/sf/°F.
    - b. Density, Manufacturer's Certified Test: 4 pcf.
    - c. Flame Spread, ASTM E84: 15 maximum.
    - d. Smoke Developed, ASTM E84: 0.
    - e. Fire Resistance Rating, ASTM E119: 3 hours.
  3. Thickness: 4-inches
  4. Width: 24-inches
  5. Product and Manufacturer: Provide one of the following:
    - a. Thermafiber Safing Insulation as manufactured by:
      - 1) USG Interiors, Incorporated, Stockton, CA.
      - 2) Or approved equal.
- H. Fire-Stop Sealants and Other Fire-Stop System Components: Provide the following:
1. Complete selection of fire stop manufacturer's recommended silicone rubber fire stop systems. Provide complete systems complying with UL 1479 with a two or three hour fire rating. Provide equal fire protection as provided by fire-rating of construction penetrated.
  2. Provide multiple component systems coordinated to meet actual conditions encountered in the Work and as recommended by the fire stop manufacturer. In addition to providing fire-resistance the fire stop systems shall also be gas and watertight.
  3. Product and Manufacturer: Provide one of the following:
    - a. 3M Fire Stop Systems as manufactured by:
    - b. 3M Incorporated, St. Paul, MN.
    - c. Or approved equal.
- I. Miscellaneous Materials and Accessories: Provide the following:

1. Adhesive for Bonding Insulation: The type recommended by the insulation manufacturer, and complying with fire-resistance requirements.
2. Mechanical Anchors: Type and size shown or, if not shown, as recommended by the insulation manufacturer for the type of application shown and condition of substrate.
3. Protection Board: Fiberboard sheathing or heavy duty asphaltic panels as recommended by the insulation manufacturer.
4. Adhesive Tapes: Complete selection of insulation manufacturer's recommended taping materials.
5. Bitumen: Asphalt, ASTM D449

2.02 MIXING

- A. Contractor shall verify that foamed-in-place cementitious insulation shall be mixed using the quantities, proportions and the pressures required in the manufacturer's written specifications and comply with the intended use.

PART 3 EXECUTION

3.01 EXAMINATION

- A. The Contractor shall examine the substrate and the conditions under which the Work is to be performed, and notify Engineer in writing of unsatisfactory conditions. Do not proceed with the Work until unsatisfactory conditions have been corrected in a manner acceptable to the Engineer.

3.02 SUBSTRATE PREPARATION

- A. Verify that surfaces to receive building insulation are clean of all debris, dirt and other contamination before installation begins in any area.
- B. Correct unacceptable Work to meet the requirements of the Section

3.03 INSTALLATION

- A. General:
  1. Comply with manufacturer's instructions for the particular conditions of installation in each case. If printed instructions are not available or do not apply to the project conditions, submit to Engineer specific recommendations from manufacturer for approval before proceeding with the Work.

## **GENERAL SPECIFICATION 07210 - BUILDING INSULATION**

---

2. Extend all insulations full thickness over entire surface to be insulated. Cut and fit tightly around obstructions, and fill voids with insulation.
  3. Apply the number of layers of insulation specified herein, each of the required thickness to provide the thermal value indicated, unless otherwise shown or required, to make up the total thickness.
- B. Preformed Concrete Masonry Unit Core Insulation:
1. Provide factory-installed preformed concrete masonry unit core insulation installed in all cores of all exterior perimeter wall concrete unit masonry construction.
  2. Install inserts in accordance with manufacturer's written specification.
  3. Concrete unit masonry Work containing damaged or mutilated preformed insulation shall not be used in the Work.
- C. Board-Type Perimeter Insulation:
1. Install perimeter insulation after concrete foundation Work has been poured and after sodium bentonite panels and prefabricated drainage mats are in-place and acceptable to Engineer.
  2. Apply double 2 foot-0 inch wide continuous layers of insulation of the required thickness. Stagger joints in insulation and butt insulation tightly together.
  3. Protect top surface of horizontal insulation (from damage during backfilling Work) by application of one of the types of protection course materials recommended by the insulation manufacturer.
  4. On vertical surfaces, set units in adhesive applied in accordance with manufacturer's instructions. Use type of adhesive recommended by manufacturer of board-type perimeter insulation.
  5. Tape bottom edge of insulation before temporarily attaching insulation to wall with mastic.
  6. Tape all joints in vertical wall insulation.
  7. Protect insulation on vertical surfaces (from damage during backfilling) by application of one of the types of protection course materials recommended by the insulation manufacturer. Set in adhesive in accordance with the recommendations of the manufacturers of the insulation and the protection course material.



- D. Cavity Wall Rigid Insulation Board:
1. Install exterior wall rigid insulation board after all concrete unit masonry Work is complete.
  2. Apply a single layer of insulation cut to fit snugly and uniformly and in continuous contact with edges of continuous masonry horizontal joint reinforcement over the entire plane of the wall.
  3. Apply exterior wall rigid insulation to exterior concrete unit masonry walls in all area shown to receive masonry outer cavity wall wythes.
  4. Set units in adhesive applied in accordance with manufacturer's instructions. Use type of adhesive recommended by manufacturer of board-type cavity wall insulation.
- E. Batt-Type Insulation:
1. Install batt insulation above ceilings and between studs and rafters as shown. Extend insulation full width, length and height in all areas shown.
  2. Fit tightly around obstructions to form a uniform insulated barrier.
- F. Loose Fill Insulation:
1. Pour granular insulation into spaces and onto surfaces to completely fill all void spaces.
  2. Screed horizontal applications to uniform thickness.
- G. Foamed-In-Place Cementitious Insulation:
1. Coordinate, locate and prepare access holes large enough to accommodate compressed air foamed-in-place insulation installation hose, at 4 foot - 0 inch centers each way, on all OSB sheet metal cladding substrates.
  2. Using manufacturer's recommended compressed air application equipment, fill all cavities completely; plug holes with non-shrink mortar or wood plugs level with face of OSB substrate after verifying that foamed-in-place cementitious insulation has completely filled cavity space level with injection portal.
- H. Safing Insulations and Fire Stop Systems:
1. Install safing insulation and fire stop systems to present a continuous fire-rated fire barrier in areas shown and at the perimeter of all fire-rated partitions and poke through floor and

wall penetrations to maintain the continuity of fire-rated construction whether or not shown.

2. Install fire stop sealants and other fire stop system components in thicknesses recommended by the manufacturer at all locations where poke through penetrations occur, all locations where other penetrations such as ducts, pipe cables, cable trays and conduit occur and at the perimeter of all fire rated walls.
3. Include all components of manufacturer's fire/smoke stop systems for complete system responsibility installed in accordance with manufacturer's written recommendations and specifications.

### 3.04 PROTECTION

- A. All components of the Work shall be protected from detrimental weather and until construction operations including, but not limited to, backfilling, framing and sheathing, aluminum siding and concrete unit masonry Work, is completed and acceptable to Engineer.
- B. Work which cannot for reasons acceptable to Engineer be covered with complete construction system before onset of weather detrimental to the Work shall be completely covered and protected in such a manner as to deflect water and weather from the installation without damaging adjacent Work.
- C. Protect building insulations from all damage and abuse until Final Acceptance by the City.

### 3.05 FIELD QUALITY CONTROL

- A. Foamed-In-Place Cementitious Insulation: Contractor shall conduct a timed, field density check at the beginning, middle and end of each day's application. Check shall be done in accordance with manufacturer's instructions and a log of results maintained and submitted to Engineer on a daily basis.
- B. In order to assure that foamed-in-place insulation has been installed in a continuous layer completely insulating all areas of the structure, infrared thermographic testing shall be performed at the completion of the insulation Work for each structure before beginning the insulation Work on the next structure, at no additional expense to the City.
- C. Submit results of all testing to Engineer along with recommendations for remedial Work. Do not delay job progress. Coordinate the submission of tests and remedial Work in a manner which does not impact the acceptability of OSB substrate and which permits expeditious completion of the sheet metal cladding Work.

3.06 ADJUSTMENT AND CLEANING

- A. Do not allow construction traffic which is not associated with the installation of the building insulation systems and related materials in the area of Work. Protect the area from access by other installers and Contractors until the Work of this Section has been incorporated into finished construction systems.
- B. System components which are dislodged, damaged, expanded, broken, penetrated, or crushed by subsequent installation operations or damaged by detrimental weather shall be immediately replaced with undamaged material in compliance with the Sections and properly protected as specified.
- C. Where testing indicates that foamed-in-place building insulation has not completely filled areas to be insulated, provide remedial Work to completely fill such areas, and retest.
- D. Only the original installer shall repair or replace deteriorated or defective Work.

3.07 INSPECTION AND ACCEPTANCE

- A. To not allow construction traffic which is not associated with the installation in the area of Work. Protect the area from access by other installers and Contractors until the Work of this Section has been incorporated into finished construction systems.
- B. System components which are dislodged, damaged, broken, penetrated or crushed by subsequent installation operations or damaged by detrimental weather shall be immediately replaced with undamaged material in compliance with the Sections and properly protected as specified.
- C. Only the original installer shall repair or replace deteriorated or defective Work.
- D. Building insulations which have become wet, damaged, or deteriorated shall be promptly removed from the Site, even if discovered in the completed Work.

END OF SECTION

**GENERAL SPECIFICATION 07210 - BUILDING INSULATION**

---

NO TEXT ON THIS PAGE

**SECTION 07221  
Roofing Insulation**

**PART 1        GENERAL**

**1.01        SUMMARY**

- A. This Section describes the general requirements for roofing insulation systems including extruded polystyrene rigid foam board-type insulation beneath all sheet metal roofing, very high load bearing extruded polystyrene rigid foam board-type insulation beneath all cast-in-place concrete rooftop wearing decks and a composite system of lightweight insulating concrete and pre-generated foam with integral expanded polystyrene rigid foam insulation board for use over non-vented substrates beneath all single-ply roofing.
- B. The Work also includes all miscellaneous materials and accessories and a Job Conditions Report from the installer of the composite roofing insulation containing information specified. Contractor shall also include the presence of full time on-site composite roofing manufacturer's Technical Representative and provide a ten year composite roofing insulation performance warranty. Contractor shall provide all labor, materials, equipment and incidentals as shown, specified and required to furnish, install and field test roofing insulation Work.
- C. The Contractor shall implement practices and procedures to meet the project's sustainability goals as identified in the Contract Documents. The Contractor shall ensure that the sustainability requirements of this Section are implemented to the fullest extent.
- D. The following index of this Section is presented for convenience:

<u>Article</u>	<u>Title</u>	<u>Page</u>
		07221-
PART 1	GENERAL .....	1
1.01	Summary .....	1
1.02	Payment.....	2
1.03	Related Sections.....	2
1.04	References.....	2
1.05	System Design Requirements .....	3
1.06	Quality Assurance.....	4
1.07	Submittals .....	6
1.08	Delivery, Storage And Handling.....	7
1.09	Project Conditions.....	8
1.10	Warranty .....	9

**GENERAL SPECIFICATION 07221 -- ROOFING INSULATION**

---

PART 2 PRODUCTS.....9  
2.01 Materials And Manufacturers .....9

PART 3 EXECUTION.....12  
3.01 Examination .....12  
3.02 Substrate Preparation .....13  
3.03 Installation.....13  
3.04 Protection .....15  
3.05 Composite Roof Insulation Field Testing .....15  
3.06 Inspection And Acceptance .....15

1.02 PAYMENT  
A. No separate payment will be made for performing any work of this Section and all costs associated thereof shall be included in the lump sum price bid for the Contract, except as provided for in the Detailed Specifications.

1.03 RELATED SECTIONS  
A. General Specification 07501 -- Single-Ply Roofing System  
B. General Specification 07611 -- Sheet Metal Roofing

1.04 REFERENCES  
A. NYCBC -- New York City Building Code  
B. NYCECCC -- New York City Energy Conservation Code  
C. ASTM C150 -- Standard Specification for Portland Cement  
D. ASTM C177 -- Steady-State Heat Flux Measurement and Thermal Transmission Properties by Means of the Guarded-Hot-Plate Apparatus, Test Method for  
E. ASTM C203 -- Breaking Load and Flexural Properties of Block-Type Thermal Insulation, Test Method for  
F. ASTM C272 -- Water Absorption of Core Materials for Structural Sandwich Construction, Test Method for  
G. ASTM C303 -- Dimensions and Density of Preformed Block-Type Thermal Insulation, Test Method for  
H. ASTM C495 -- Compressive Strength of Lightweight Insulating Concrete, Test Method for

## **GENERAL SPECIFICATION 07221 -- ROOFING INSULATION**

---

- |      |                            |    |  |
|------|----------------------------|----|--|
| I.   | ASTM C518                  | -- | Standard Test Method for Steady-State Thermal Transmission Properties by Means of the Heat Flow Meter Apparatus                        |
| J.   | ASTM C550                  | -- | Measuring Trueness and Squareness of Rigid Block Thermal Insulation, Test Method for   |
| K.   | ASTM C578                  | -- | Rigid Cellular Polystyrene Thermal Insulation, Specification for   |
| L.   | ASTM C796                  | -- | Foaming Agents for Use in Producing Cellular Concrete Using Preformed Foam, Test Method for  |
| M.   | ASTM C869                  | -  | Foaming Agents Used in Making Preformed Foam for Cellular Concrete, Specification for  |
| N.   | ASTM D696                  | -- | Standard Test Method for Coefficient of Linear Thermal Expansion of Plastics Between -30°C and 30°C with a Vitreous Silica Dilatometer |
| O.   | ASTM D1621                 | -- | Compressive Properties of Rigid Cellular Plastics, Test Method for   |
| P.   | ASTM D1623                 | -- | Tensile and Tensile Adhesion Properties of Rigid Cellular Plastics, Test Method for  |
| Q.   | ASTM D5116                 | -- | Standard Guide for Small-Scale Environmental Chamber Determinations of Organic Emissions from Indoor Materials/Products                |
| R.   | ASTM E84                   | -- | Surface Burning Characteristics of Building Materials, Test Method for   |
| S.   | ASTM E96                   | -- | Water Vapor Transmission of Materials, Test Method for   |
| T.   | FM                         | -- | Factory Mutual Incorporated, Approval Guide  |
| U.   | UL                         | -- | Building Materials Directory Fire Resistance Directory   |
| 1.05 | SYSTEM DESIGN REQUIREMENTS |    |  |
| A.   | Performance Requirements:  |    |  |

1. Roofing insulation Work shall withstand the uplift forces of wind, as defined by the roofing guarantee. Refer to General Specification 07501 - Single-Ply Roofing System, and General Specification 07611 - Sheet Metal Roofing.
2. Failures of the roofing insulation Work in bond or anchorage to the substrate, or within the insulation, will be considered failures of materials or workmanship under the insulation performance warranty.

**B. Substitutions**

1. Manufacturer of the primary roofing systems shall be manufacturers who find the generic types of insulation specified herein as acceptable and bondable if installed according to the roofing manufacturer's standards for complete product and performance responsibility.
2. The thickness of the composite insulation system, the maximum step between layers of expanded polystyrene rigid board insulation, and the minimum slope-to-drain shall not vary from what is shown, specified and approved.

**C. Sustainable Design Requirements:**

1. Low Emitting: Insulation tested according to ASTM D 5116 and shown to emit less than 0.05-ppm formaldehyde.
2. Insulation shall be produced using a blowing agent with zero ozone-depleting potential. HCFC-142b or HCFC-141b shall not be used.
3. Recycled Content of Roof Insulation Products: Postconsumer recycled content plus one-half of preconsumer recycled content not less than 15 percent.

**1.06 QUALITY ASSURANCE**

**A. Composite Roofing Insulation Installer Qualifications:**

1. Subcontract roofing insulation Work to an installer approved in writing, who has qualified for appointment and has been trained by the manufacturer of the composite roofing insulation system.
2. Engage a single installer skilled, trained and with successful experience in the installation of the type of composite roofing insulation specified, and equipped to perform workmanship in accordance with both the requirements of the manufacturer of the composite roofing insulation and of the single-ply roofing manufacturer so that there will be unequivocal responsibility for the performance of the roofing insulation Work.



## **GENERAL SPECIFICATION 07221 -- ROOFING INSULATION**

---

3. Submit proofing of acceptability of installer by manufacturer to Engineer.
- B. Performance Criteria:
1. The thicknesses shown are for the thermal conductivity, k-value at 75 F specified for each material.
  2. Comply with Factory Mutual Technical Advisory Bulletin 1-29 for recommendations concerning requirements for 1-90 securement.
  3. Provide composite roofing insulation system recommended by the manufacturer for use on non-vented substrates.
- C. Erection Tolerances: Provide the following for composite roofing insulation:
1. Provide minimum of 1/8-inch leveling slurry coat of insulating concrete over the top of cast-in-place concrete roofing decks.
  2. Finished system shall not pond water and shall provide a uniformly sloped surface to low point of roof drains. If at any time up to the time of Final Acceptance the roofing shows signs of ponding water, the composite roofing insulation system shall be repaired to provide uniform slope to drain.
- D. Requirements of Regulatory Agencies: Comply with fire-resistance ratings as shown, and as required by governing authorities and the New York City Building Code and comply with the following roofing insulation requirements:
1. Materials and equipment submitted for DEP's approval by the Contractor shall have met, at the time of their submittal, the certification and material acceptance requirements of the NYC Department of Buildings, unless otherwise required by the Authority Having Jurisdiction over the Work.
  2. All material provided under this Section shall comply with the Detailed Specifications.
  3. Comply with all applicable requirements of governing authorities and codes for all Work.
  4. U.L. requirements for Roofing Deck Constructions which are rated "UL Construction No. 1".
  5. Factory Mutual requirements for "Class 1" construction, for fire hazard and 1-90 wind resistance.

1.07 SUBMITTALS

- A. The Contractor shall submit Shop Drawings for approval of the Engineer. Submittals shall include, but not be limited to:
1. Samples: Submit for approval the following:
    - a. Each fastener to be used in the Work.
    - b. 12-inch by 12-inch sample of specified rigid board-type insulation and composite insulation system.
  2. Shop Drawings: Submit for approval the following:
    - a. Manufacturer's specifications and installation instructions for type of insulation required. Include data substantiating that the materials comply with specified requirements.
    - b. Weights of all equipment to be used on roofing.
    - c. Field verified locations of all roof penetrations, drain locations, and deck deflections.
    - d. Complete layout of all roofing insulation showing sizes, placement and number of courses and methods of fastening.
    - e. All required roofing insulation details approved by the roofing insulation manufacturer and the manufacturer of the respective roofing systems.
    - f. Laboratory test results for Thermal Resistance Values based on ASTM C177 or ASTM C518 for actual composite roofing insulation system shown and specified.
  3. Certifications: Submit Job Conditions Report as specified and, in addition, include a notarized statement from the full-time on-site Technical Representative and installer that the composite roofing insulation system was installed according to manufacturer's written recommendations.
  4. Sustainable Design Submittals:
    - a. Environmental Materials Reporting Form (EMRF) Recycled Content. Provide the following information:
      - 1) Name of Product and Manufacturer.
      - 2) Cost of product: Material cost only (excluding labor and equipment).

- 3) The percentage (by weight) of post-consumer and pre-consumer recycled content for the submitted product.
    - b. VOC Reporting Form:
      - 1) For adhesives used onsite and within the building's weatherproofing system provide the VOC content in grams/Liter (g/L) less water and exempt compounds.
  5. Sustainable Design:
    - a. Recycled Content: Submit percentage of recycled content for each material or product. No product shall contain CFC, HCFC (hydrochlorofluorocarbon) or any Resin base chemical.
    - b. Regional Materials: Submit location of product manufacturer and distance from manufacturing location to the project site.
- 1.08 DELIVERY, STORAGE AND HANDLING
- A. Delivery of Materials:
    1. Do not deliver roofing insulation materials to the project site before time of installation.
    2. Deliver materials in manufacturer's original, undamaged packages or acceptable bulk containers.
    3. Materials shall be manufactured and delivered from manufacturing locations that are closest to the project site to reduce transportation costs and emissions.
  - B. Storage of Materials:
    1. Do not allow roofing insulation materials to become wet or soiled, or covered with ice or snow.
    2. Store packaged materials to protect them from the element and physical damage.
  - C. Handling of Materials:
    1. Comply with manufacturer's recommendations for handling, storage and protection.
    2. Do not use cement which shows indication of moisture damage, caking or other signs of deterioration.

1.09 PROJECT CONDITIONS

- A. Pre-Roofing Conference: Provide both a representative of the composite roofing insulation system manufacturer and the foreman of the installer who will actually work on this job at the pre-roofing conference specified in General Specification 07501 - Single-Ply Roofing System.
- B. Environmental Requirements:
  - 1. Do not install insulation when weather conditions are such that the deck is not completely dry, or where there is no assurance that the insulation can be completely protected from the weather by the end of the day.
  - 2. For applications of composite roofing insulation system when the temperature is expected to fall below 40°F submit written installation recommendations of the composite insulation system manufacturer confirming acceptability of the conditions encountered. Contractor shall verify that composite roofing insulation system installed under such adverse weather conditions meet all material and performance requirements specified. Record actual conditions of installation, including intervals between system component placement, weather and temperature conditions, temporary uses of roofing (if any) and other pertinent installation factors and submit notarized information signed by manufacturer's full-time on-site technical representative to Engineer.
  - 3. Hot water is not available at the project site and shall be supplied by composite roofing insulation installer as required by installation conditions.
  - 4. Potable water is not available at the project site and shall be provided by composite roofing insulation installer.
- C. Protection: Do not overload the building structure with the weight of stored materials or use of equipment.
- D. Sequencing:
  - 1. Proceed with and complete the Work only when materials, equipment and tradesmen required for the installation of the roofing membrane and sheet metal roofing over the insulation are at the site and are ready to follow with this Work immediately (same day) behind the insulation Work.
  - 2. Do not install any more board-type insulation each day than can be covered with the complete sheet metal roofing system by the end of that working day.

3. Follow composite roofing insulation manufacturer written requirements for installation timing sequence for Work. Do not place more leveling slurry coat than can be completely covered with insulation within 30 minutes nor more expanded polystyrene insulation than can be covered with insulating concrete within 4 hours of placing insulation.

1.10 WARRANTY

- A. The manufacturer of the composite roofing insulation system shall warrant directly to the City that the roofing insulation will remain in a re-roofable condition, for a period of 10 years, should the roofing membrane require replacement; that the roofing insulation will remain in place even if the roofing membrane sustains wind damage; and that the roofing insulation's actual resistance to heat flow will be at least 80 percent of the installed value, provided the roofing remains leak free.

PART 2 PRODUCTS

2.01 MATERIALS AND MANUFACTURERS

- A. Extruded Polystyrene Rigid Board Roofing Insulation: Provide the following between sheet metal structural roof decks and oriented strand board sheet metal roofing substrate:
  1. Rigid, rectangular boards of extruded polystyrene complying with ASTM C578, Type VI.
  2. Physical Properties: Provide the following:
    - a. Minimum Compressive Strength, (at 5 percent deformation), ASTM D 1621: 40 psi.
    - b. Flame Spread, ASTM E84: 5 maximum.
    - c. Smoke Development, ASTM E84: 165 maximum.
    - d. Vapor Transmission, ASTM E96: 1.0 perms/inch.
    - e. Thermal Resistance per inch, ASTM C177: 5.0 deg F x h x sq. ft./Btu x in. at 75 deg F
    - f. Maximum Water Absorption, ASTM C272: 0.10% by volume.
    - g. Flexural Strength, ASTM C203: 60 lbs/in<sup>2</sup>.
  3. Size: 24-inches by 96 inches by 2-inch thick; cut as required to fit within profile of sheet metal roofing adjustable radiused hat section.

## GENERAL SPECIFICATION 07221 -- ROOFING INSULATION

---

4. Number of Layers: As indicated by thickness of roofing insulation shown.
5. Product and Manufacturer: Provide one of the following:
  - a. ROOFMATE HighLoad 40 as manufacture by:
    - 1) The Dow Chemical Company, Midland, MI.
    - 2) Or approved equal.
- B. Very High Load bearing Extruded Polystyrene Roofing Insulation: Provide the following above all liquid-applied membrane waterproofing inverted roofing beneath cast-in-place concrete rooftop wearing slabs:
  1. Rigid, closed-cell, thermally stabilized, very high load bearing extruded foam board insulation consisting of extruded polystyrene modified resin complying with ASTM C578, Type V.
  2. Physical Properties: Provide the following:
    - a. Thermal Conductivity (k), ASTM C177 and ASTM C518: 0.20 Btu/in./hr./sf/EF.
    - b. Thermal Resistance per inch, ASTM C177 and ASTM C518: 5.0 deg F x h x sq. ft./Btu x in. at 75 deg F.
    - c. Compressive Strength (psi at 5% deformation) ASTM D1621: 100 psi minimum.
    - d. Flexural Strength, ASTM C203: 100 psi minimum.
    - e. Coefficient of Thermal Expansion, ASTM D696:  $3.5 \times 10^{-5}$  inches/inches x deg F.
    - f. Water Vapor Absorption, ASTM C272: 0.3% by volume maximum.
    - g. Water Vapor Permeance, ASTM E96: 0.8 perms/inch maximum.
    - h. Flame Spread, ASTM E84: 5.
    - i. Smoke Developed, ASTM E84: 165 maximum.
  3. Thickness: Two layers each 2-inches thick.
  4. Width: 24-inches.
  5. Length: 96-inches.
  6. Product and Manufacturer: Provide one of the following:
    - a. STYROFOAM 100 HIGH LOAD as manufactured by:

- 1) The Dow Chemical Company, Midland, MI.
  - 2) Or approved equal.
- C. Composite Roofing Insulation: Provide the following beneath all single-ply membrane roofing system:
1. Expanded Polystyrene Rigid Board: Provide the following board as a system component of the composite roofing insulation system for use beneath all single-ply roofing:
    - a. Rigidexpanded polystyrene modified resin bead board with bead fusion of 80 percent minimum with no visible voids.
    - b. Molded blocks air dried for minimum of six weeks with less than 0.5 percent residual pentane prior to fabrication.
    - c. Size: 24-inches by 48-inches with pattern of 30 holes and 30 slots per board.
    - d. Dimension Tolerances, ASTM C 550:
      - 1) Length:  $\pm 1/16$  inch.
      - 2) Width:  $\pm 1/16$  inch.
      - 3) Thickness:  $\pm 1/16$  inch.
      - 4) Squareness:  $\pm 1/16$  inch.
      - 5) Flatness:  $\pm 1/32$  inch.
    - e. Physical Properties:
      - 1) Density, ASTM C578: Type I, 1 lbs/cu. ft.
      - 2) Thermal Resistance, (R at 75°F), ASTM C177 and ASTM C518:  $R=3.85$  s.f./°F/hr/BTU.
      - 3) Thermal Conductivity (k at 40°F), ASTM C177 and ASTM C518:  $U=0.25$  BTU/in. hr/s.f./°F.
      - 4) Coefficient of Thermal Expansion, ASTM D696:  $3.5 \times 10^{-5}$  in/in./°F.
      - 5) Compressive Strength (10% deflection), ASTM D1621: 13-17 psi.
      - 6) Flexural Strength, ASTM C203: 28-35 psi.
      - 7) Tensile Strength, ASTM C1623: 16-20 psi.
      - 8) Water Vapor Transmission, ASTM E96: 1.2-2.2 perms.

## GENERAL SPECIFICATION 07221 -- ROOFING INSULATION

---

- 9) Water Vapor Adsorption, ASTM C272: Less than 2 percent
  - 10) Flame Spread, ASTM E84: 5.
  - 11) Smoke Developed, ASTM E84: 40-85.
2. Thicknesses: Stair-stepped arrangement with thicknesses of boards comprising all but top two inches and bottom 1/8 inch of composite roofing insulation system and of total system thicknesses as shown and specified.
  3. Insulating Concrete: Provide the following:
    - a. Portland Cement: ASTM C150, Type I, II or III.
    - b. Calcium Chloride: Not permitted.
    - c. Pre-generated Foam: Concentrated liquid with clear identification as to manufacturer and type of material carrying FM and UL approved labels complying with ASTM C796 and ASTM C869.
    - d. Water: Potable, clean, and free from deleterious amounts of acid, alkali and organic materials.
    - e. Physical Properties: Provide the following physical properties for the insulating concrete design mix:
      - 1) Minimum Compressive Strength, ASTM C495: 200 psi.
      - 2) Density at Placement: 38-48 pcf.
      - 3) Oven Dry Density: 30-36 pcf.
  4. Reinforcing Mesh: 2160-2-1619 galvanized mesh as recommended by the manufacturer of the composite roofing insulation.
  5. Product and Manufacturer: Provide one of the following:
    - a. Insulcel Roofing Insulation System as manufactured by:
      - 1) Siplast Incorporated, Irving, TX.
      - 2) Or approved equal.

### PART 3 EXECUTION

#### 3.01 EXAMINATION

- A. The Contractor shall examine the substrate and the conditions under which the roofing insulation Work is to be performed, and notify Engineer in writing of any unsatisfactory conditions. Do not proceed



with the Work until unsatisfactory conditions have been corrected in a manner acceptable to Engineer.

3.02 SUBSTRATE PREPARATION

- A. Verify that fire-resistant cement board insulation underlayment is in place on sloping metal decks and that channel-shaped attachment angles and adjustable radiused hat sections are properly installed over all areas to receive sheet metal roofing Work.

3.03 INSTALLATION

A. General:

1. Comply with manufacturer's instructions for the particular conditions of installation in each case. If printed instructions are not available or do not apply to the project conditions, consult the manufacturer's full-time on-site Technical Representative for specific recommendations before proceeding with the Work. All such discussions shall be recorded in writing in Job Conditions Report and shall be incorporated into the Work only when acceptable to Engineer.
2. Coordinate heights of wood blocking to provide flush transition between roofing insulation Work and perimeter wood blocking.
3. Extend insulations full thickness as shown over entire surface of the roofs.
4. Cut and fit board-type insulation tightly around obstructions, and fill voids with insulation. Keep back 1/4 inch for all vertical flashings.

B. Laying Board-Type Insulation Units for Sheet Metal Roofing System:

1. Apply four courses of rigid board insulation over entire surface of roofs receiving sheet metal roofing between continuous adjustable radiused hat sections.
2. Mechanically fasten in accordance with the requirements of the applicable fire and insurance ratings and primary roofing manufacturer's recommendations, and apply in accordance with the recommendations of the manufacturer of the insulation, mechanical fastener and completed roofing system manufacturer.
3. Install insulation board with the long joints between boards perpendicular with incline of deck. Cut roofing insulation and taper edges of boards where curvature of deck requires, to fit snugly beneath oriented strand board sheet metal roofing substrate Work. Remove ridges between insulation boards and

provide a smooth transition between boards following curvature of adjustable radiused hat sections.

C. Laying Composite Roofing Insulation System for Single-Ply Roofing System:

1. Place insulating concrete using approved equipment after sufficient mixing time to provide a consistent, thoroughly uniform consistency that will screed to a smooth surface and achieve the compressive strength specified.
2. Provide insulating concrete leveling slurry to a depth of 1/8-inch above the top of deck.
3. Place expanded polystyrene rigid board insulation into the slurry within 30 minutes of insulating concrete placement with joints staggered in a running bond pattern.
4. Tightly butt all rigid boards together and install in a manner that provides full contact of slurry to board, and with adequate pressure to cause insulating concrete to enter the locking/keying openings of the rigid board.
5. Install rigid boards in a stair-stepped configuration with maximum step down of 1 inch between boards, over entire plane of roof surface beneath all single-ply roofing. Cut boards as required in order to maintain 2 inches of insulating concrete cover at insulation step in compliance with slope-to-drain and high point and low point elevations shown.
6. Within four hours of rigid board placement place 2 inches of insulating concrete over rigid boards and screed to a smooth, consistently dense, uniformly sloped plane leading to roof drains at low points. Insure that all locking/keying openings in rigid board are completely filled with insulating concrete. Provide finish and other system features acceptable to single-ply roofing installer.
7. Include reinforcing mesh as part of the composite roofing insulation system to help control crack formation and distribute forces within the roofing insulation system.
8. Provide high and low point elevations shown.

D. Laying Board-Type Insulation Units for Liquid-Applied Membrane Waterproofing Inverted Roofing:

1. Apply two courses of very high load bearing rigid board insulation over entire surface of roofs.
2. Adhesively adhere boards, staggering joints between courses.

3. Be prepared to follow immediately with cast-in-place concrete sloped-to-drain wearing slab.

3.04 PROTECTION

- A. Do not permit construction period traffic over completed roofing insulation Work, except as required for roofing.
- B. Protect insulation Work from exposure to moisture, damage and deterioration, primarily by prompt installation of roofing Work to be placed over the insulation.
- C. Do not expose completed Work to prolonged exposure to elements in excess of seven days.
- D. Do not use completed roofing insulation as a temporary working surface without protection approved by insulation installer.

3.05 COMPOSITE ROOF INSULATION FIELD TESTING

- A. Check cast density hourly at the point of placement. Include reports as part of notarized Job Conditions Report information and submit to Engineer.
- B. Retain a minimum of four 3-inch by 6-inch cylinder material specimens for each day's pour. Protect specimens from damage and temperature extremes and test in accordance with ASTM C495. Submit results of test as part of notarized Job Conditions Report and submit to Engineer.

3.06 INSPECTION AND ACCEPTANCE

- A. Insulation which has become wet, damaged, or deteriorated shall be promptly removed from the job, even if already installed.
- B. Correct all improperly sloped, chipped, cracked, improperly set, ridged or rough areas in the insulation to provide substrate acceptable to roofing manufacturer and Engineer.
- C. Final Acceptance will be contingent upon the receipt by the Engineer of a Job Conditions Report certifying conformance of the Work with the requirements of the Section and which includes all information requested by the Sections.

END OF SECTION

NO TEXT ON THIS PAGE

**SECTION 07271  
Vapor and Air Barriers**

**PART 1 GENERAL**

**1.01 SECTION INCLUDES**

- A. Vapor and air barriers as specified herein shall include, but not be limited to reinforced polyethylene fabric, seam tape, fabric repair tape, and appurtenances.
- B. Vapor barriers or air barriers shall be provided where shown on the Contract Drawings, specified in the Detailed Specifications, or as required for a complete installation.
- C. The following index of this Section is presented for convenience:

<u>Article</u>	<u>Title</u>	<u>Page</u>
		07271-
PART 1	GENERAL.....	1
1.01	Section Includes.....	1
1.02	Payment.....	1
1.03	References.....	2
1.04	System Description.....	2
1.05	Quality Assurance.....	2
1.06	Submittals.....	3
1.07	Delivery, Storage And Handling.....	4
PART 2	PRODUCTS.....	4
2.01	Manufacturers.....	4
2.02	Materials.....	4
PART 3	EXECUTION.....	6
3.01	Examination.....	6
3.02	Surface Preparation.....	6
3.03	Installation.....	6
3.04	Protection.....	6
3.05	Adjustment.....	7

**1.02 PAYMENT**

- A. No direct payment will be made for vapor barriers, air barriers, accessories, or appurtenances; the cost shall be included in the prices for the Work, except as provided for in the Detailed Specifications

## GENERAL SPECIFICATION 07271 - VAPOR AND AIR BARRIERS

---

### 1.03 REFERENCES

- A. ASTM D882 - Standard Test Method for Tensile Properties of Thin Plastic Sheeting
- B. ASTM D1709 - Standard Test Methods for Impact Resistance of Plastic Film by the Free-Falling Dart Method
- C. ASTM D2582 - Standard Test Method for Puncture-Propagation Tear Resistance of Plastic Film and Thin Sheeting
- D. ASTM D3776 - Standard Test Methods for Mass Per Unit Area (Weight) of Fabric
- E. ASTM D4833 - Standard Test Method for Index Puncture Resistance of Geomembranes and Related Products
- F. ASTM E84 - Standard Test Method for Surface Burning Characteristics of Building Materials
- G. ASTM E96 - Standard Test Methods for Water Vapor Transmission
- H. NYBC - New York City Building Code
- I. NFPA 701 - Standard Methods of Fire Tests for Flame Propagation of Textiles and Films

### 1.04 SYSTEM DESCRIPTION

- A. Regular vapor barrier, such as that used under slabs on grade, shall be a three-ply laminate combining two layers of rubber modified high density polyethylene and a high strength cord grid reinforcing mesh, manufactured in one piece in sizes up to 120 feet by 200 feet, with as few seams as possible, in accordance with the requirements of the Contract Documents.
- B. Fire retardant vapor barrier or air barrier, such as that used on roof slabs, or as part of a wall system, shall be a three-ply polyethylene vapor barrier, reinforced with a heavy duty cord grid, manufactured in one piece in sizes up to 100 feet by 200 feet, with as few seams as possible, in accordance with the requirements of the Contract Documents. Fire retardant material shall have a Class I, Class A flame spread rating when tested in accordance with ASTM E84.

### 1.05 QUALITY ASSURANCE

- A. Requirements of Regulatory Agencies: All fire retardant vapor barriers and/or air barriers work shall comply with fire-resistance ratings as

shown, and as required by governing authorities and the New York City Building Code and shall be in accordance with the following requirements:

1. Material and Equipment Acceptance Division of the Board of Standards and Appeals of New York City Department of Buildings: Where, in order to be incorporated into the Work, a particular item or product system specified by Engineer requires acceptance by the New York City Commissioner of Buildings, the Contractor shall assist the product manufacturer in obtaining such approval, without additional expense to the City, and in providing the City with an approved certified copy of the board's resolution giving the MEA number for the item or product system which shall be submitted to Engineer as part of the Shop Drawing approval process. Contractor may submit, in place of products specified by Engineer, products which are "equal" in all ways to the product specified but which have already achieved an MEA number. Such "or equal" product submissions shall not change the requirements of these Sections as to performance, required features or properties, as determined by Engineer, and shall not require additional compensation to Contractor or additional expense to the City. Final acceptance of "equal" is at the sole determination of Engineer.
2. In those instances where the Commissioner of Buildings requires a certificate of compliance of the manufacturer or producer certifying that the item or product system was tested and is equivalent to material of the same kind and quality regularly being manufactured by such manufacturer or producer Contractor shall provide all such certificates to the Commissioner of Buildings without additional expense to the City.

1.06 SUBMITTALS

- A. The Contractor shall submit Shop Drawings for approval of the Engineer. Submittals shall include, but not be limited to:
  1. Product Data: The Contractor shall submit copies of specifications, installation instructions and general recommendations from the vapor barrier and/or air barrier manufacturer. Manufacturer's data substantiating that the materials comply with the requirements shall be included.

1.07 DELIVERY, STORAGE AND HANDLING

A. Delivery of Materials:

1. Materials shall not be delivered to the project site before the time of installation.
2. Materials shall be delivered in sufficient quantities to allow continuity of the Work.

B. Storage of Materials:

1. Materials shall be stored in original, undamaged containers with manufacturer's labels and seals intact.
2. All materials shall be stored in a dry, enclosed area, out of direct sunlight, off the ground and away from all possible contact with water, ice, or snow.
3. Damage to materials during storage shall be prevented primarily by minimizing the amount of time they are stored at the project site before being incorporated into construction systems.

C. Handling of Materials:

1. Materials shall be handled carefully in order to avoid damage or breakage.
2. Materials shall not be exposed to detrimental conditions or physical damage. Materials which are so exposed shall be permanently removed from the project site and shall not be incorporated into the Work.
3. Materials shall be handled in such a manner so as to prevent inclusion of foreign materials.
4. Packages or containers shall not be opened until all necessary, preparatory Work is complete and installation is to begin immediately. Materials shall not be allowed to become wet or soiled or covered with ice or snow.

PART 2 PRODUCTS

2.01 MANUFACTURERS

- A. Vapor and air barriers: Vapor barrier and/or air barrier manufacturer shall be as specified in the Detailed Specifications.

2.02 MATERIALS

- A. General: Vapor barrier systems and air barrier systems shall each comprise materials from one manufacturer.



**GENERAL SPECIFICATION 07271 - VAPOR AND AIR BARRIERS**

---

- B. Regular Vapor Barrier Membrane: Regular vapor barrier membrane shall be a three-ply reinforced polyethylene fabric, and shall meet or exceed the following performance standards when tested in accordance with the following methods:

<b>Property</b>	<b>ASTM Test</b>	<b>Result</b>
Weight	ASTM D3776	28 lbs./MSF
Puncture Propagation Tear	ASTM D2582	17 lbs.
Permeance	ASTM E96	0.037 grains/hr/sf
Drop Dart	ASTM D1709	490 g
3" Tensile Strength	ASTM D882	96 lbs./5800 psi
Puncture Strength	ASTM D4833	26.6 lbs.

- C. Fire Retardant Vapor or Air Barrier Membrane: Fire retardant membrane shall be a three-ply laminate fabric combining two layers of fire retardant, linear, low density polyethylene reinforced with a high strength cord grid, and shall meet or exceed the following performance standards when tested in accordance with the following methods:

<b>Property</b>	<b>ASTM Test</b>	<b>Result</b>
Weight	ASTM D3776	43 lbs./MSF
Puncture Propagation Tear	ASTM D2582	26 lbs.
Permeance	ASTM E96	0.035 grains/hr/sf
Cold Crack	ASTM D1709	-15 degrees F
Drop Dart	ASTM D1709	700 g
3" Tensile Strength	ASTM D882	100 lbs./3268 psi
Puncture Strength	ASTM D4833	36.0 lbs.
Flame Spread	ASTM E84	0
Smoke Developed	ASTM E84	50
NFPA 701 Large Scale Fire Resistance Test		Pass

- D. Seam Tape: Seam tape shall be the manufacturer's standard double-sided asphaltic pressure sensitive mastic type seaming tape.

- E. Fabric Repair Tape: Fabric repair tape shall be the manufacturer's standard self-adhesive tape used to repair any holes in vapor barrier which may be caused by excessive abuse.

**PART 3 EXECUTION**

**3.01 EXAMINATION**

- A. The Contractor shall verify that areas to receive vapor barriers and/or air barriers are properly prepared and completed to final elevations.

**3.02 SURFACE PREPARATION**

- A. Surfaces to receive vapor barriers shall be clean and free of all foreign matter. Slab subgrade shall be properly compacted in accordance with Division 2 requirements, and shall be smooth with no rutted or lumpy areas.
- B. Surfaces to receive air barriers shall be clean and free of all foreign matter.

**3.03 INSTALLATION**

- A. General: Vapor barriers and air barriers shall be installed in strict accordance with the manufacturer's instructions. Barriers shall be smooth and wrinkle free.
- B. Seams: Seams in barrier fabric shall be accomplished using the manufacturer's standard seam tape. Fabric overlap and seam tape placement shall be in accordance with the manufacturer's instructions. In ambient temperatures of 60 degrees F and less, additional heat sources shall be applied to the seams to achieve an effective bond.
- C. Pipe Penetrations: Pipes and other penetrations through the barriers shall be sealed using manufacturer's standard pipe boots, which shall be installed in accordance with the manufacturer's directions.
- D. Repairs: Holes in vapor barriers and/or air barriers shall be brought to the attention of the Engineer, and if, in the opinion of the Engineer, the holes are reparable, the holes shall be repaired using the manufacturer's standard fabric repair tape, applied in strict accordance with the manufacturer's instructions.

**3.04 PROTECTION**

- A. All components of the Work shall be protected from detrimental weather and damage until construction operations are completed and acceptable to Engineer.
- B. Work which cannot, for reasons acceptable to Engineer, be covered with complete construction system before the onset of weather detrimental to

the Work shall be completely covered and protected in such a manner as to deflect water and weather from the installation without damaging adjacent Work.

- C. Vapor and air barrier systems shall be protected from all damage and abuse from all other Contractors and installers involved in the Work until Final Acceptance by the City.

3.05 ADJUSTMENT

- A. System components which are dislodged, damaged, expanded, or penetrated by subsequent installation operations or damaged by detrimental weather shall be immediately replaced with undamaged material in compliance with the Sections and properly protected as specified.

END OF SECTION

NO TEXT ON THIS PAGE

**SECTION 07611  
Sheet Metal Roofing**

**PART 1 GENERAL**

**1.01 SECTION INCLUDES**

- A. This Section describes the general requirements for sheet metal roofing which includes a complete system of custom curved and straight, custom finished, stainless steel roof panels, drainage gutter bars, batten caps, all custom and standard flashings, and flexible underlayments, substrate boards and sheathing panels, connectors, stainless steel attachment angles, shop-curved adjustable radiused hat sections, accessories and miscellaneous components recommended by the sheet metal roofing system manufacturer specified for a complete weather- and watertight and permanent installation complying with all governing codes and the requirements of this Section whether or not shown, and concealed, minimum UL Class 1-90 anchorage system construction. Sheet metal roofing system shall not employ any sealants or other non-metallic detailing methods to achieve weather- and water tightness. This complete system shall also include all fasteners, trim, drip edge, eave and rake flashing, custom and factory-formed transition flashings, expansion joint flashings, fascias and rain drainage system components including sloping grate drains and gutters. Contractor shall supply a thirty year warranty against leakage and an approved quality assurance stepped-down job mock-up before proceeding with the work and all labor, materials, equipment and incidentals as shown, specified and required to furnish, install and place into satisfactory service all sheet metal roofing work.
  
- B. The following index of this Section is presented for convenience:

<u>Article</u>	<u>Title</u>	<u>Page</u>
		07611-
PART 1	GENERAL .....	1
1.01	Section Includes .....	1
1.02	Related Section .....	2
1.03	Payment.....	2
1.04	References.....	2
1.05	Submittals .....	3
1.06	Quality Assurance.....	6
1.07	Delivery, Storage And Handling.....	11
1.08	Job Conditions .....	11
1.09	Substitutions.....	12
1.10	Guarantee .....	13

## GENERAL SPECIFICATION 07611 - SHEET METAL ROOFING

---

PART 2	PRODUCTS.....	13
2.01	Materials And Manufacturers .....	13
2.02	Factory-Formed Metal Roofing Fabrication.....	17
2.03	Preformed Gutter And Downspout Fabrication.....	19
PART 3	EXECUTION.....	20
3.01	Inspection.....	20
3.02	Substrate Preparation .....	20
3.03	Installation.....	21
3.04	Protection .....	23
3.05	Adjustment And Cleaning.....	23
1.02	RELATED SECTION	
A.	General Specification 07221 - Roofing Insulation	
1.03	PAYMENT	
A.	Payment for sheet metal roofing shall be made as provided for in Detailed Specification.	
B.	No separate payment will be made for individual sheet metal roofing system components and accessories and all costs associated thereof shall be included as part of the price bid for each type of sheet metal roofing system.	
1.04	REFERENCES	
A.	NYCBC - New York City Building Code	
B.	ASTM B32 - Solder Metal, Standard Specification for	
C.	ASTM D523 - Specular Gloss , Standard Test Method for	
D.	ASTM E283 - Determining the Rate of Air Leakage Through Exterior Windows, Curtain Walls and Doors Under Specified Pressure Differences Across the Specimen, Standard Test Method for	
E.	ASTM E331 - Water Penetration of Exterior Windows, Skylights, Doors, and Curtain Walls by Uniform Static Air Pressure Difference, Standard Test Method for	
F.	FM 1-28 - Factory Mutual Engineering Corporation (FM Global), Wind Design [for buildings].	
G.	FM 1-31 - Factory Mutual Engineering Corporation (FM Global), Panel Roof Systems	

## GENERAL SPECIFICATION 07611 - SHEET METAL ROOFING

---

- H. SMACNA - Sheet Metal and Air Conditioning Contractors National Association, Incorporated, Architectural Sheet Metal Manual
- I. UL 580 - Tests for Up-lift Resistance of Roof Assemblies, Standard for
- J. AISI/NiDI 9012 - American Iron and Steel Institute/Nickel Development Institute, Finishes for Stainless Steel
- K. AISC 27 - American Institute for Steel Construction, Design Guide 27: Stainless Steel
- L. SSINA - Specialty Steel Industry of North America, Stainless Steel Fasteners, Designer Handbook
- M. SSINA - Specialty Steel Industry of North America, Specifications for Stainless Steel, Designer Handbook
- N. SSINA - Standard Practices for Stainless Steel Roofing, Flashing, Copings
- O. AMP/NAAMM AMP 503 - Architectural Metal Products Division of National Association of Architectural Metal Manufacturers, Finishes for Stainless Steel

### 1.05 SUBMITTALS

- A. The Contractor shall submit Shop Drawings for approval of the Engineer. Submittals shall include, but not be limited to:
  - 1. Samples: Submit for approval the following:
    - a. Two finishes are required.
    - b. Provide each type of roof pan, roof trim, roof flashing, and custom metal roof fabrication, 2 foot - 0 inches long by full-width with custom rolled specular reflectivity controlled uniform matt finish in accordance with ASTM D523 for exposed sheet metal roofing components in order to provide consistency of low reflectivity finish specified and exposed eave, rake and fascia flashing

- metal complete with custom controlled AMP 503 No. 4 uniform finish.
  - c. One of each type cleat, gutter bar, batten cap and UL approved clip and fastener employed, with statement of intended use.
  - d. Samples will be reviewed by Engineer for color and finish only.
  - e. Compliance with other requirements is the responsibility of Contractor.
2. Shop Drawings: Submit for approval the following:
- a. Copies of manufacturer's specifications, standard and custom large scale detail drawings.
  - b. Roof plans and installation instructions for sheet metal roofing.
  - c. Isometric drawings of all flashing intersections and transitions with adjacent construction materials.
  - d. Custom flashing transition components and trim and other custom metal fabrications.
  - e. Indicate extent and location of each type of finish for each system component specified.
  - f. Profiles of sheet metal roofing pan units, and the details of forming, jointing, ventilation, gaskets (if any), internal supports, anchorages, trim, batten caps and gutter bars, flashing, and transitions with adjacent flashing.
  - g. Show forming and soldering details of weatherproofing at edges, terminations and penetrations of the sheet metal roofing work.
  - h. Show 1/4 inch to the foot scale layout of entire work locating and dimensioning all sheet metal roofing, flashing and trim.
  - i. Show hold-down clips, adjustable radius hat sections and attachment angle locations.
  - j. Establish pattern of OSB roof sheathing panels on each area of sheet metal roofing and indicate fastener spacing.
  - k. Show all details at 3 inch to the foot scale, indicating all internal components and intersection members, details and special fabrication techniques.



- l. Completely coordinated Shop Drawings showing the integration of this work with substrate and roofing insulation, supports and penetrations.
  - m. Indicate continuous composite wood/recycled plastic sleeper and cement board locations and dimensions beneath sheet metal roofing work.
  - n. Coordinate, show, locate and detail all snow management system and lightning system protection system components.
  - o. Provide drawings detailing all penetrations, fasteners, connections and supports for such systems.
  - p. Provide calculations indicating sheet metal roofing system resistance to horizontal sliding.
  - q. Do not exceed maximum horizontal load resistance of system when locating snow management system snow retention bars.
  - r. Provide performance calculations based on specified wind up-lift resistance standards and governing authorities for all areas of roof including critical high load wind uplift areas along perimeters, ridges and corners.
  - s. Locate additional purlins, sleepers and fasteners positioned to resist localized loadings and as required for snow management system components, built-in gutters and other features required for the work.
3. Certificates:
  - a. Copy of letter of sheet metal roofing manufacturer's certification designating the roofing installer's current application status.
  - b. Provide copies of material purchase receipts, signed by a certified and licensed Notary Public, verifying that material purchased for the work complies with material designations specified as confirmed by approved Shop Drawings.
  - c. Copy of certificates verifying compliance with ASTM E331 and ASTM E285.
4. Contractor's Review:
  - a. Accompanying approval request, submit to Engineer a written statement signed by Contractor, stating that the

Drawings and Sections for sheet metal roofing and flashing have been reviewed with an agent of the sheet metal roofing material manufacturer and that he is in agreement that the selected systems are proper, compatible and that the details shown are not in conflict with the sheet metal roofing manufacturer's roofing and flashing details.

- b. Show by copy of transmittal form that a copy of the statement has been transmitted to the manufacturer.
5. Statement of Application: Upon completion of the work, submit a notarized statement to Engineer signed by Contractor stating that the work complies with the requirements of these Sections and the installation methods comply with the manufacturer's printed instructions, meets requirements regarding system performance, and were proper and adequate for the condition of installation and use.
6. Submit guarantees as specified.
7. Submit UL "Follow-Up Service" validation procedure.

1.06 QUALITY ASSURANCE

A. Performance Criteria:

1. All sheet metal roofing work shall be permanently watertight, and not deteriorate in excess of manufacturer's published limitations. To achieve this, the manufacturer shall provide only the highest quality materials, details and installation techniques at no additional expense to the City.
2. Wind Uplift Resistance: Tested and listed by UL (UL 580 test) for minimum Class 1-90 approval rating on completed sheet metal roofing system. Provide roof panel manufacturer which subscribes to Underwriters Laboratories' "Follow-Up Service" assuring continued product compliance with UL requirements. Provide all clips, purlins, sleepers and fasteners as recommended by the sheet metal panel manufacturer in order to provide a finished sheet metal roofing system meeting minimum UL Class 1-90 wind uplift conditions, in all ways.
3. Provide analysis based on FM 1-28, FM 1-31, Ground Roughness Category D, MRI 100 years, and the New York City Building Code to determine detailing and fabrication requirements to resist wind uplifts at field, perimeter, ridge and corner conditions. Determine requirements based on strictest criteria.

4. Water Penetration: No evidence of uncontrolled leakage for steady rain with winds up to 90 miles per hour when tested in accordance with ASTM E331, at an inward static air pressure differential of 12.5 pounds per square foot.
5. Air Infiltration: When tested according to ASTM E283 at 10 pounds per square foot of pressure air infiltration of panels shall not be greater than 0.06 cubic feet per minute per square foot of panel area.
6. Snow Management System:
  - a. Provide additional clips, supports, continuous composite wood/ recycle plastic sleepers, snow retention plates, angles and fasteners capable of resisting snow loading.
  - b. Sheet metal roofing manufacturer may anticipate a preliminary estimate of loading parallel to the roof panel on each batten of 5000 pounds with snow management system brackets spaced 36 inches on center at each batten. Coordinate final loading at time of Shop Drawing submission, providing additional snow retention lines as necessary to distribute horizontal sliding loads over the entire plane of the roof. Loading shall not be less than loading specified.
7. Lightning Protection System: Provide attachments and penetrations for lightning protection system shown. Coordinate system to provide penetrations only at batten bars. Provide formed aluminum mounting brackets, finished to match roof panels, welded watertight to lightning rods.
8. Provide fastener load pullout test results for all fasteners used in the roof assembly.
9. Comply with specified manufacturer's system performance requirements and submit as part of Shop Drawing review.
10. Sheet metal roofing manufacturer shall be responsible for providing all flashing and custom flashing detailing in compliance with the Contract Documents and approved Shop Drawings.
11. Anchorage system shall be exposed but detailed and fabricated such that exposed fasteners do not penetrate through roofing system allowing all entering water to be drained to exterior by gutter-shaped batten bars and detailed so that panels are free to move for expansion and contraction and with provision for removal of individual panels without disturbing adjacent panels.

12. Sheet metal roofing system shall not rely upon sealants or non-metallic detailing methods to achieve weather- and watertightness.
- B. Installation Tolerances: Maximum Alignment Variation: 1/4-inch in 40 feet-0 inches.
- C. Installer Qualifications:
1. Engage a single installer skilled, trained and with successful experience in the installation of custom finished stainless steel sheet metal roofing and with successful experience in the erection of the types of materials required; and who agrees to employ only tradesmen with specific skill and experience in this type of work. Submit names and qualifications to Engineer along with the following information on a minimum of three successful projects:
    - a. Names and telephone numbers of owners, architects or engineers responsible for projects.
    - b. Approximate contract cost of the sheet metal roofing.
    - c. Amount of area installed.
  2. Engage either the sheet metal roofing manufacturer or submit proof to Engineer of acceptability of installer to sheet metal roofing manufacturer. Provide an installer who is pre-qualified by the manufacturer of the sheet metal roofing.
  3. Installers shall wear roofing manufacturer's recommended footwear and handwear for all work.
- D. Pre-installation Conference:
1. Prior to the installation of the sheet metal roofing and associated work, Contractor shall schedule and meet at the site with the sheet metal roofing installer, the installer of each component of associated work, the installers of deck or substrate construction to receive roofing work, the installers of other work in and around roofing which must follow the sheet metal roofing work, including mechanical work, Engineer and other representatives directly concerned with performance of the work. Review foreseeable methods and procedures related to the sheet metal roofing work, including but not necessarily limited to, the following:
    - a. Review project requirements, including Drawings, Sections and other Contract Documents.

- b. Review required submittals, both completed and yet to be completed.
  - c. Review status of substrate including drying, structural loading limitations and similar considerations.
  - d. Review availability of materials, tradesmen, equipment and facilities needed to make progress and avoid delays.
  - e. Review required inspection, testing, certifying and accounting procedures.
  - f. Review weather and forecasted weather conditions, and procedures for coping with unfavorable conditions.
  - g. Review regulations concerning code compliance, environmental protection, health, safety, fire and similar considerations.
  - h. Review procedures needed for protection of roofing during the remainder of the construction period.
2. Reconvene the meeting at the earliest opportunity if additional information must be developed in order to conclude the subjects under consideration.
  3. Record any revisions or changes agreed upon, reasons therefor, and parties agreeing or disagreeing with them.
- E. Job Mock-Up:
1. Before proceeding with final purchase of materials and fabrication of sheet metal roofing components, prepare a mock-up of the work including all components shown, indicating the final relationship and configurations of the various parts and components of the work and the workmanship quality which shall be achieved in the work.
  2. Include all items that are part of the sheet metal roofing system including, but not limited to, cement board insulation underlayment, continuous composite wood/recycled plastic sleepers, stainless steel purlins, rigid board insulation, OSB sheet metal roofing substrate, flexible base sheet roof panel underlayment, rosin-sized paper and metal roofing and batten seam construction including an example of eave, ridge and gutter flashing. Provide a stepped-down mock-up leaving a 4 foot-0 inches wide section of each system component exposed for Engineer's inspection.
  3. Incorporate materials and methods of fabrication and installation which are identical with project requirements. Install mock-up

- on actual segmented chord metal deck. Accepted job mock-up may be incorporated into the finished work.
4. Build as many job mock-ups as required to obtain Engineer's acceptance of the work.
  5. Sheet metal roofing work which proceeds without an approved job mock-up shall be stopped, removed and re-installed, without question from Contractor, after job mock-up approval, at no additional expense to the City.
- F. Standards: Comply with applicable standards and recommendations of SMACNA, Architectural Sheet Metal Manual, for the fabrication and installation of sheet metal roofing, except to the extent more stringent requirements are specified.
- G. Requirements of Regulatory Agencies:
1. Comply with applicable insurance rating bureau requirements as required by the governing building code, unless more restrictive requirements are specified.
  2. Comply with UL Construction for minimum Class 1-90 wind uplift rating.
  3. SMACNA, Architectural Sheet Metal Manual.
- H. Source Quality Control:
1. Obtain all sheet metal roofing, flashing and accessories from the same manufacturer.
  2. Engage a manufacturer who requires that a Technical Representative or Regional Manager be present at the start of the work and who requires that the completed work be inspected by a Technical Representative of the sheet metal roofing manufacturer.
  3. For custom rolled matt finished roofing, establish color, specular reflectivity uniformity and finish testing criteria in accordance with ASTM D523 for exposed sheet metal roofing components in order to provide consistency of low reflectivity finish specified for roofing.
  4. For exposed rake, eave and fascia flashing and trim provide all faces with a uniform, bright, mill-polished surface obtained by finishing with a 150 - 220 mesh abrasive, following initial grinding with coarser abrasives. The finish shall be characterized by very fine parallel "grit lines" and be within a uniform range established as either a AISI/NiDI 9012 and AMP

503 AISI No. 4 or 5 finish, with final finish established by Sample submission as approved by Engineer.

1.07 DELIVERY, STORAGE AND HANDLING

A. Delivery of Materials:

1. Deliver sheet metal roofing materials and all accessories dry and undamaged, with manufacturer's protection and original product identifications and packaging intact.
2. Deliver sheet metal roofing materials in bundles with banded, sustainably obtained wood surrounds and end caps intact.

B. Storage of Materials:

1. Store all roofing materials and accessory materials in a manner that will protect them from exposure to sun, standing water and condensation; with good air circulation around each piece.
2. Store all roofing materials and accessory materials above ground in a covered area protected from dirt, damage and weather with one end elevated for drainage.
3. Do not store in contact with wood or concrete or other materials that might cause staining, damage or corrosion.
4. If panels become wet, immediately separate sheets, wipe dry with a clean cloth and allow to air dry.

C. Handling of Materials:

1. Do not subject roofing materials and accessory materials to bending or stress.
2. Do not damage edges or handle material in a manner that will cause scratches, warps or dents.
3. Remove strippable protective film, immediately preceding panel installation.

1.08 JOB CONDITIONS

A. Environmental Conditions:

1. Proceed with sheet metal roofing and associated work only when weather conditions will permit unrestricted use of materials and quality control of the work being installed, complying with the Section requirements and with the recommendations of the roofing materials manufacturers.
2. Proceed only when Contractor and his installer are willing to guarantee the work as required and without additional reservations and restrictions.

3. Record decisions, conditions and agreements to proceed with the work when weather conditions might be unfavorable. State the reasons for proceeding, with the names of the persons involved along with the changes, if any, or revisions, requirements or terms of the Contract.

B. Protection:

1. Provide continuous protection of materials against damage primarily by storing materials under cover and above ground and away from other construction traffic.
2. Do not allow cutting, welding or grinding of other work to occur by this, or other Contractors, near finished sheet metal roofing work.

C. Scheduling:

1. Proceed with the sheet metal roofing and associated work only after curbs, blocking, continuous composite wood/recycled plastic sleepers, vents, drains and projections through the substrate have been installed, and when the substrate construction and framing of openings is completed.
2. Proceed with and complete the work only when materials, equipment and tradesmen required for the installation of other roofing system components are at the Site and are sufficiently advanced to permit the unencumbered installation of the sheet metal roofing in order to provide a complete roofing system at each work area.
3. Install all sheet metal roofing and associated work in a manner that will insure a complete roofing system at the end of each day's work. Do not advance the installation of any one material beyond that which is necessary for proper sequencing of the sheet metal roofing work.

1.09 SUBSTITUTIONS

- A. Do not change material gage, seam spacing or construction details after Shop Drawing approval by Engineer.
- B. Provide gages of material specified for all work or of heavier gage if calculations based on performance criteria submitted as part of Shop Drawing approval process indicates the need for heavier gage material. All such substitutions shall be at no additional expense to City. Where compliance with performance criteria indicates that materials of lesser gage may be adequate, provide specified gage.



1.10 GUARANTEE

- A. Provide manufacturer's thirty-year warranty against system leakage.
- B. Provide written guarantee agreeing to replace sheet roof panel work which fails in material or workmanship within three years of the date of Final Acceptance. Failure of materials or workmanship shall include, but is not limited to, the following:
  - 1. Deterioration in excess of normal weathering and lack of water- or weather tightness.
  - 2. Imperfections, by reason of defective materials, workmanship or arrangement of the various parts shall be made good to the satisfaction of the City at Contractor's expense.

PART 2 PRODUCTS

2.01 MATERIALS AND MANUFACTURERS

- A. Curved and Flat Exterior Prefabricated Roof Panels:
  - 1. Custom-fabricated, factory-formed, Type 316, 24 gage stainless steel complying with ASTM A167 of modular widths and lengths shown.
  - 2. Provide each roof panel edge with a 2-3/8-inch high flange with continuous hooked edges for engaging batten gutter bars.
  - 3. Provide factory corrective-leveled panels.
- B. Curved and Straight Extruded Aluminum Batten Bar: Continuous, straight and factory-curved to template tolerance, 0.051-inch aluminum gutter 2-3/8-inch high with extruded aluminum sliding nuts located a minimum of 24-inches on centers and closer as determined by required performance analysis.
- C. Curved and Straight Batten Caps: 24 gage Type 316 stainless steel continuous batten caps with pre-punched holes for stainless steel machine screws. Provide independent batten caps. Integrated cap and roof sheets shall not be approved by Engineer.
- D. Custom Flashing and Trim:
  - 1. Provide custom curved flashings, flashings and vented flashings where required, and sheet metal contour closure trim components, support spacer strips, sheet cleat strips, cap flashings, base and drip flashings, closure and cleats, custom transition flashings, pan stops and closures, surrounds at openings, soffits, and similar components of the work as indicated or as required for a permanently watertight and complete installation.

2. Provide factory-fabricated trim components.
  3. Except as otherwise shown or specified, match the material, gage, and finish of the exterior metal roofing.
  4. Provide all concealed fasteners for flashing and trim work.
- E. Built-In Gutters, Downspouts and Scupper Drains:
1. Provide 24 gage, Type 316 stainless steel gutters, downspouts, and custom flashings and custom transition flashings.
  2. Finish all such rain drainage system components to match sheet metal roofing system.
  3. Scupper Drains: Provide stainless steel 45 degree threaded outlet scupper drains with flush-set grates secured with vandal-proof screws complying with the following:
    - a. Size drains for downspout sizes shown.
    - b. Provide flush grates with 40 square inches of free area.
    - c. Product and Manufacturer: Provide one of the following:
      - 1) 9785-U (1540T) as manufactured by:
        - a) Smith Incorporated, Houston, TX.
        - b) Or approved equal.
- F. Snow Management and Lightning Protection Systems:
1. Provide custom system components of Type 316 stainless steel using components which maintain weather- and watertightness of system and which are in compliance with manufacturer's requirements for guaranteed construction and which do not rely upon sealants or non-metallic detailing techniques in order to resist water penetration.
  2. Lightning point penetrations and snow management system supports shall be detailed and coordinated by sheet metal roofing manufacturer to occur at battens only.
  3. Continuous plates, angles and fasteners shall be minimum 3/16-inch stainless steel.
- G. Fire-Resistive Rigid Cement Board Roof Insulation Underlayment:
1. Exterior grade glass fiber cement board, 1/2-inches thick, placed continuously beneath all rigid board roofing insulation on metal roof decking with mechanical fasteners as required by Factory Mutual.

2. Provide board which shows no deterioration after 100 freeze/thaw cycles complying with ASTM C666.
  3. Product and Manufacturer: Provide one of the following:
    - a. DUROCK Exterior Cement Board as manufactured by:
      - 1) United States Gypsum Company/USG Industries, Incorporated, Port Reading, NJ.
      - 2) Or approved equal.
- H. OSB Sheet Metal Roofing Substrate Board:
1. Provide FMRC approved oriented strand board with an Exposure Durability Rating Classification of 1 and Span Rating of 24/16 and complying with CABO National Evaluation Report 108.
  2. Environmental Profile: Provide the following features:
    - a. Verify panels supplied for the work were manufactured only at facilities using regenerative thermal oxidation pollution-control technology with 90 percent heat recovery capability.
    - b. Provide OSB which does not contain or emit any formaldehyde and which has been manufactured using a 100 percent methyl disocyanate polyurethane resin adhesive binder for both inner and outer ply layers.
  3. Size: 7/16-inch thick by 4 foot - 0 inches by 9 foot - 0 inches.
  4. All panels shall bear the APA Performance Rating Stamp identifying the product as complying with these Sections.
  5. Product and Manufacturer: Provide one of the following:
    - a. Oriented Strand Board Sheathing Panels as manufactured by:
      - 1) Louisiana-Pacific Corporation, Nashville, TN.
      - 2) Or approved equal.
- I. Anchors, Clips and Cleats:
1. Fastener Clips: Minimum UL 90 assembly rated clips; 24 gage stainless steel.
  2. Sheet and Prepunched Cleats: Provide minimum of 2-inch wide of Type 316 stainless steel. Minimum length shall provide a fold of 1/2-inch to be locked into the seam of folded edge of metal flashing with other end folded back over fastener heads.

- J. Adjustable Radiused Hat Sections and Attachment Angle Purlins:
1. Provide 16 gage Type 316 stainless steel custom factory-fabricated adjustable radiused hat sections and attachment angle purlins, fabricated to the combined requirements of the OSB manufacturer=s recommendations for substrate edge clearance fastening dimensions and as required to provide sufficient surface area for fasteners and clips required to resist wind uplift for sheet metal roofing.
  2. Provide adjustable radiused hat sections shop-curved to template tolerances.
- K. Flexible Base Sheet Fabric Underlayment: Provide the following:
1. Non-perforated, heavy-weight asphalt-fiberglass base sheet, fully coated both sides.
  2. Product and Manufacturer: Provide one of the following:
    - a. GAFGLAS #75 Base Sheet as manufactured by:
      - 1) GAF Corporation.
      - 2) Or approved equal.
- L. Miscellaneous Materials:
1. All fasteners used at all locations shall be 1/4-inch diameter stainless steel and of sufficient length to penetrate metal decking, stainless steel purlins and composite wood/recycled plastic sleepers a minimum of 7/8-inch. Self-tapping stainless steel fasteners may be tipped with steel if recommended by the sheet metal roofing manufacturer.
  2. Exposed fasteners for batten caps and gutter bar connection shall be 1/4-inch diameter 20 by 1-1/2 stainless steel round head machine screws 24 inches on center maximum.
  3. Blind Rivets:
    - a. Blind rivets shall not be exposed in the work. Reinforce, increase gage, provide extrusions or hem and cleat material in order to avoid the use of blind rivets, wherever possible.
    - b. Where acceptable to Engineer and unavoidable as determined by Engineer on approved Shop Drawings and where concealed by finished metal in the finished work, blind rivets may be used. Blind rivets shall not be substituted, during installation at the site, for other

fastening methods approved on Shop Drawings by Engineer.

c. Where approved for use in finished work by Engineer, blind rivets shall be Type 316 stainless steel.

4. Rosin-Sized Building Paper Slip Sheet: Smooth, unsaturated building paper weighing approximately 5 to 6 pounds per 100 square feet.
5. Solder: 60 percent pig lead and 40 block tin conforming to ASTM B32
6. Flux: Non-corrosive; as recommended by the prefabricated sheet metal roofing manufacturer.

M. Product and Manufacturer:

1. Curved and Flat Stainless Steel Sheet metal Roofing System with Type AC@ Batten with AArchitex@ and AISI Finishes as manufactured by:
  - a. Overly Manufacturing Company.
  - b. Or approved equal.

## 2.02 FACTORY-FORMED METAL ROOFING FABRICATION

A. General: Provide 24 gage roofing panels as follows:

1. Comply with the dimensions, profile limitations, gages and fabrication details of specified sheet metal roofing manufacture unless more stringent requirements are specified herein.
2. Fabricate Work with lines and corners of exposed units true and accurate. Form exposed faces flat and free of buckles, excessive waves and avoidable tool marks, considering the temper and reflectivity of the metal. Provide uniform, neat seams with minimum exposure of solder.
3. Prefabricate those components of the system at the factory recommended by the manufacturer including, ready for field assembly exterior roof pans, joint cleat, anchor clips, flashing, trim and accessories.
4. Fabricate components and assemble units to comply with the performance requirements specified for the completed installation of the Work.
5. Form and fabricate sheets, seams, strips, cleats, valleys, ridges, edge treatments, integral flashings for rain drainage and other components of sheet metal roofing work to profiles, patterns and drainage arrangements shown, both on the Contract Drawings

and by the sources specified, and as required for permanently leakage-proof construction.

6. Curve panels in the Shop to template tolerances to avoid oil canning of roofing panels.
7. Do not place horizontal transverse seams at low pitch roof areas.
8. Fabricate sheet metal roofing and supports as indicated on approved Shop Drawings.
9. All system components requiring field soldering shall be pretinned at the factory.
10. Support and Anchorage: Fabricate units with adequate provisions for support and anchorage, of the types needed for the indicated method of installation and loadings specified.

**B. Fabricated Metal Flashing and Trim:**

1. Shop-fabricate metal flashing and trim to comply with profiles and sizes shown, and to comply with manufacturer's recommended details in compliance with detailing and fabrication requirements specified as shown on Shop Drawings approved by Engineer.
2. Prepare components to receive concealed fasteners, anchoring and connection devices. Exposed fasteners and lap joints for joining and anchoring stainless steel flashing and trim shall not be approved by Engineer. Concealed fastening techniques shall be used for fabrication of all stainless steel flashing and trim.
3. Joints between sections of stainless steel flashing and trim shall be formed using interlocking butt joints with backplate reinforcing using threaded studs welded to the back of the stainless steel flashing and trim and supported from steel members using low-profile stainless steel zee-clips with finger slots and locking keyhole slots for invisible support and assembly of face sheet flashing and trim.
4. Comply with metal producers' recommendations for tinning, soldering and cleaning flux from metal.

**C. Gutters, fascias, rakes, cap flashing, expansion joints, custom transition flashing and similar flashing shall not rely upon sealants in order to achieve weather- and watertightness. Provide metal profiles and configurations which achieve weather- and watertightness while still permitting movement without the use of bitumen, coal tar, EPDM, butyls, urethanes and similar non-metallic detailing approaches.**

- D. On all metal counterflashings and cap flashings provide completely shop-fabricated corners and special flashings; soldered to insure watertight joints.
- E. All metal flashings, coping, counterflashing, and similar work in all areas of the building roof shall be formed of the sheet metal specified herein.
- F. Make surfaces free of waves and buckles with lines, arrises and angles sharp and true; curves shall be smooth.
- G. Do all cutting, fitting, drilling or other operation in sheet metal required to accommodate work of other trades. Provide all items essential to complete the installation, though not specifically shown or specified, of the same kind, quality, and type as similar items utilized elsewhere in the building.
- H. Comply with SMACNA, and details approved by Engineer at time of Shop Drawing submission, which rely only upon metal profiles and assemblies to achieve weather- and watertightness.

2.03 PREFORMED GUTTER AND DOWNSPOUT FABRICATION

- A. General:
  - 1. Comply with the dimensions, profile limitations, gages and fabrication details of specified sheet metal roof panel manufacturer.
  - 2. Prefabricate all components of the system at the factory, ready for field assembly.
  - 3. Fabricate components and assemble units to comply with the performance requirements specified for the completed installation of the work.
  - 4. Form and fabricate sheets, seams, strips, cleats, expansion joints, edge treatments, integral flashings for rain drainage Work and other components of preformed gutter and downspout work to profiles, patterns and drainage arrangements shown and as required for permanently leakage-proof construction.
  - 5. Provide mechanical double-locked seams for all construction. Provide system using all metal components to achieve watertightness. System shall not rely on sealants, adhesives or membrane flashing to achieve watertightness.
- B. Built-In Gutters and Downspouts:
  - 1. Provide gutter backs 1/2-inch minimum higher than fronts.

2. Provide single gutter lengths to 30 feet-0 inches maximum. Allow for 3/4-inch expansion in 30 feet - 0 inches.
3. Gutter expansion joint details and fabrication shall be based on SMACNA Plate No. 6. More stringent requirements and details for intergrating expansion joints into the sheet metal roofing system shall be as approved by Engineer at time of Shop Drawing submission.

**PART 3 EXECUTION**

**3.01 INSPECTION**

- A. The Contractor shall examine the alignment of the substrate before erection of the sheet metal roofing work begins and notify Engineer in writing of unsatisfactory conditions. Do not proceed with the sheet metal roofing work until unsatisfactory conditions have been corrected in a manner acceptable to Engineer.
- B. Verify to Engineer gage of sheet metal roofing and flashing brought to the Site are the same gages shown on approved Shop Drawings by actual measurement of on-site material in the presence of Engineer.

**3.02 SUBSTRATE PREPARATION**

- A. Verify that fire-resistant cement board insulation underlayment is in place on sloping metal decks and continuous composite wood/recycled plastic sleepers are properly installed maximum of 2 foot - 0 inches on centers over all areas to receive sheet metal roofing work, and closer as required by special conditions shown on approved Shop Drawings.
- B. Coordinate sheet metal roofing work with adjoining work to provide a permanently leakproof, secure and non-corrosive installation.
- C. Do not proceed with the Work until all sheet metal roofing flashing and trim has been coordinated with other Work.
- D. Install segmented chord attachment angles parallel with slope of metal roof deck, and equidistant from rakes and perpendicular to continuous composite wood/recycled plastic sleepers, to permit installation of continuous gutter bars directly above adjustable radiused hat sections. Coordinate segments with deck segments to permit aligned, level and smoothly curved installation of adjustable radiused hat sections establishing uniform sloped and curving plane for installation of OSB substrate panels. Provide spacing of segmented chord attachment angles in compliance with uniform panel dimensions and batten locations in accordance with the design concept shown and approved Shop Drawings.



- E. Before installing oriented strand board and rigid roofing insulation install cross-wise attachment angles running perpendicular to segmented chord attachment angles to reduce span of all OSB sheet metal roofing substrate panels to 1 foot - 4 inches maximum.
- F. Install rigid roofing insulation as specified in General Specification 07221 - Roofing Insulation.
- G. Install all oriented strand board with the long dimension, the strength axis of the panel, perpendicular to the roof slope, with all edges and ends of panels positioned over adjustable radiused hat sections and with bearing surface dimension as recommended by OSB manufacturer providing required 1/8 inch minimum space at panel to panel ends and edges and in compliance with the OSB manufacturer=s written recommendations. Offset ends in adjacent rows of OSB panels to form a 3 foot - 0 inch stepped and staggered pattern.
- H. Provide self-tapping screws 6 inches on centers along all panel edges and ends. Space screws 12 inches on center at intermediate cross-wise attachment angles running perpendicular to roof slope.
- I. Using stainless steel nails, install two layers of flexible asphalt-coated fiberglass underlayment over OSB panels beginning at bottom of slope and shingling edges of underlayment perpendicular to roof slope. Provide overlap of 3 inches between edges of underlayment, with the upper layer overlap shingled in the direction of water flow for positive water runoff. Provide minimum 6 inch overlaps at ends of rolls.
- J. Install rosin-sized roofing paper over flexible asphalt-coated fiberglass underlayment as recommended by sheet metal roofing manufacturer.

### 3.03 INSTALLATION

- A. General:
  - 1. Separate dissimilar metals and isolate work from incompatible substrates by use of underlayments specified. Comply with manufacturer's recommendations for other forms of protection of the sheet metal roofing system against corrosion.
  - 2. When work abuts or members into adjacent dissimilar metals, the juncture shall be executed in a manner which facilitates drainage.
  - 3. Provide thermal expansion for running trim, flashings, gutters and other items exposed for more than 15 feet - 0 inches continuous length. Maintain a watertight installation at expansion seams. Locate expansion seams at 10 feet - 0 inch intervals, and 2 feet - 0 inch each side of corners and intersections and at high points of flashing and trim work.

4. Fabricate and install the Work with lines and corners of exposed units true and accurate. Form exposed faces flat and free of buckles, excessive waves and avoidable tool marks, considering the temper and reflectivity of the metal.
  5. Conceal fasteners and expansion provisions in exposed Work, and locate so as to minimize the possibility of leakage. Provide expansion joint systems using only metal components. Install safety flashings below expansion seams. Field-installed expansion joints shall be watertight, as specified, and not rely upon safety flashings as primary water seals.
  6. Provide integrally installed cleat-type anchorages for metal flashings and trim and all metal pans, spaced no greater than 12 inches on center and arranged to relieve stresses from building movement, and thermal expansion and contraction.
- B. Provide batten seams and gutter bars equidistant from rakes, with uniform panel dimensions and in accordance with the design concept shown.
  - C. Anchor component parts of sheet metal roofing securely in place providing for necessary thermal, structural and wind uplift resistance and movement.
  - D. Do not exceed fastener spacing recommended by the sheet metal roofing manufacturer.
  - E. Provide minimum of two fasteners securing gutter bar through OSB panel to stainless steel adjustable radiused hat sections at 18 inches on center. Pre-drill fastener holes as required.
  - F. Provide mitered corner assemblies. Avoid having gaps, laps, or rivets at corner intersections.
  - G. Locate stainless steel purlin sleepers closer together, and with additional fasteners, at critical wind uplift roof areas as determined by manufacturer as part of Shop Drawing submittal and as approved by Engineer.
  - H. Fasten flashings and accessories 12 inches on center.
  - I. Do not use exposed fasteners on the exterior panel faces.
  - J. Drive all fasteners normal to the surface and to a uniform depth.
  - K. Install all special flashing and trim shapes required to maintain permanent weather tightness.
  - L. Install units with lines and corners true and accurate in alignment and location.

3.04 PROTECTION

- A. Do not permit construction period traffic over completed sheet metal roofing work. Only the original installer shall be permitted in the area of sheet metal roofing work and only as required to comply with the work of this Section.

3.05 ADJUSTMENT AND CLEANING

- A. Set sheet metal roof panels plumb, level, and true to line, without warp or rack.
- B. Do not use sheet metal roof panel sheets, trim members, and flashing sheets, in which holes have been made in locations where fasteners are not required. Holes plugged with sealant or solder shall not be considered acceptable repair. Holes plugged with “goof screws” shall not be considered acceptable repair. Remove such work from the Site and replace with new undamaged material.
- C. Clean exposed surfaces of sheet metal roofing work of every substance before leaving the Site and immediately (same day) after completion of installation. Comply with cleaning recommendations of the sheet metal roofing manufacturer.
- D. Do not erect components which have become scarred, chipped, discolored or otherwise damaged or defaced. Roof panels or flashing which have holes, cuts, gouges, or dents shall be removed from the work. Repairs to correct such panels shall not be approved by Engineer.
- E. Do not permit workmen, or others, to step directly on the sheet metal roofing and flashing work or to place or move equipment over the work. Protect surfaces of sheet metal roofing during installation of adjoining work.
- F. Remove and replace with new material sheet metal roofing and component parts of the work, including finish, which have been damaged.
- G. At the completion of the work, clean or replace adjacent work, as may be required, marred by the work of this Section.
- H. Leave sheet metal roofing and flashing perfectly flat, free from dents, burrs, scratches, holes, discolorations or other blemishes.
- I. Remove all materials and debris and leave the site of the work in clean condition.

END OF SECTION

NO TEXT ON THIS PAGE

**GENERAL SPECIFICATION 07620 - SHEET METAL FLASHING AND TRIM**

---

**SECTION 07620  
Sheet Metal Flashing and Trim**

**PART 1 GENERAL**

**1.01 SUMMARY**

- A. This Section describes the general requirements for sheet metal flashing and trim for a complete water- and weather tight installation complying with all governing codes and standards.
- B. The Contractor shall provide all labor, materials, equipment and incidentals necessary to perform the work of this Section as shown on the Contract Drawings, specified herein or in the Detailed Specifications, or required otherwise for a complete installation.
- C. The Contractor shall implement practices and procedures to meet the project's sustainability goals as identified in the Contract Documents. The Contractor shall ensure that the sustainability requirements of this Section are implemented to the fullest extent.
- D. The following index of this Section is included for convenience:

<u>Article</u>	<u>Title</u>	<u>Page</u>
		07620-
PART 1	GENERAL.....	1
1.01	Summary.....	1
1.02	Payment.....	2
1.03	Related Sections.....	2
1.04	References.....	2
1.05	System Design Requirements.....	2
1.06	Quality Assurance.....	3
1.07	Submittals.....	3
1.08	Delivery, Storage And Handling.....	5
1.09	Project Conditions.....	5
1.10	Warranty.....	6
PART 2	PRODUCTS.....	6
2.01	Manufacturers.....	6
2.02	Materials.....	7
2.03	Fabrication.....	8
PART 3	EXECUTION.....	9
3.01	Examination.....	9
3.02	Preparation.....	9
3.03	Installation.....	9

**GENERAL SPECIFICATION 07620 - SHEET METAL FLASHING AND TRIM**

---

- 3.04 Field Quality Control For Cavity Wall Flashing .....11
- 3.05 Adjustment And Cleaning.....11
- 1.02 PAYMENT
  - A. No separate payment will be made for performing any work of this Section and all costs associated thereof shall be included in the lump sum price bid for the Contract, except as provide for in the Detailed Specifications.
- 1.03 RELATED SECTIONS
  - A. General Specification 04200 -- Unit Masonry
  - B. General Specification 07501 -- Single-Ply Roofing System
  - C. General Specification 07900 -- Caulking and Sealants
- 1.04 REFERENCES
  - A. NYCBC -- New York City Building Code
  - B. ASTM A666 -- Specification for Annealed or Cold-Worked Austenitic Stainless Steel Sheet, Strip, Plate and Flat Bar
  - C. ASTM B32 -- Standard Specification for Solder Metal
  - D. FM 1-49 -- FM Global Property Loss Prevention Data Sheet, Perimeter Flashing
  - E. SMACNA -- Sheet Metal and Air Conditioning Contractors National Association, Incorporated, Architectural Sheet Metal Manual
- 1.05 SYSTEM DESIGN REQUIREMENTS
  - A. Sheet metal flashing and trim to be provided under this Section shall include complete systems of flashing and counterflashing at penetrations in roofing; interlocking, mechanically-keyed, 3-way ribbed stainless steel metal masonry cavity wall flashing and miscellaneous system components such as cast-in-place and built-in-place reglets and other accessory components; miscellaneous flashings not supplied under the work of other Sections; miscellaneous accessories, fasteners and incidental system components.
  - B. Installation of the systems shall meet the requirements of FM Approval Rating Class 1-90 construction, without relying upon sealants or other non-metallic detailing and fabricating techniques to achieve weather-and watertightness.
  - C. Performance Criteria:

## GENERAL SPECIFICATION 07620 - SHEET METAL FLASHING AND TRIM

---

1. Sheet metal flashing and trim shall be permanently watertight, and not deteriorate in excess of manufacturers' published limitations.
2. Comply with fabrication details recommended by SMACNA and the sheet metal flashing and trim manufacturers, as approved by Engineer at time of Shop Drawing submission.
3. Provide completely weather- and watertight wall and single-ply roofing metal flashing systems. Contractor shall provide only the highest quality materials and methods of construction and installation as recommended by sheet metal flashing and trim manufacturers in compliance with governing authorities and as approved by Engineer at time of Shop Drawing submission.

### D. Sustainable Design Requirements

1. Recycled Content of Steel-Sheet Flashing and Trim: Postconsumer recycled content plus one-half of preconsumer recycled content shall not be less than 25 percent.
2. Low Emitting Materials: All adhesives and sealants used onsite and within the building's weatherproofing system shall meet the VOC content limits for the work as specified in the Contract Documents.

- E. Project-specific system/design requirements will be provided (if necessary) in the Detailed Specifications in order to update the requirements given herein or to supplement other requirements given in the Contract Drawings.

### 1.06 QUALITY ASSURANCE

- A. Engage installers skilled, trained and with successful experience in the detailing, fabrication and installation of each type of sheet metal flashing and trim work required who are recognized sheet metal contractors, equipped to perform workmanship in accordance with the Contract Documents and approved Shop Drawings so that there will be undivided responsibility for the performance of each flashing and trim component of the work.

### 1.07 SUBMITTALS

- A. The Contractor shall submit Shop Drawings for approval of the Engineer. Submittals shall include, but not be limited to:
1. Installer Qualifications: Submit names and qualifications to Engineer along with the following information on a minimum of three successful projects:

## GENERAL SPECIFICATION 07620 - SHEET METAL FLASHING AND TRIM

---

2. Names and telephone numbers of owners, architects or engineers, responsible for the projects.
  3. Approximate contract prices for sheet metal flashing and trim.
  4. Size of area installed
- B. Samples: Submit for approval the following:
1. Typical examples of sheet metal flashing and trim profiles, 12-inches long with all fasteners, clips, and supports required for the Work. 12-inch by 12-inch sheet of each item specified and 6-inch long pieces of each required system component to be used in the work.
  2. Each fastener type required marked as to type of material and with their intended purpose in the work.
- C. Shop Drawings: Submit for approval the following:
1. Copies of manufacturers' specifications, installation instructions and general recommendations for sheet metal flashing and trim requirements.
  2. Include manufacturer's data substantiating that the materials comply with the requirements.
  3. Provide Shop Drawings showing the coordination of the Work with General Specifications 04200 – Unit Masonry and 07501 – Single-Ply Roofing System.
  4. Provide detailed Shop Drawings showing all profiles of sheet metal flashing and trim systems to be used in the work, fully dimensioned, located, quantified and presented such that sequence of installation is acceptable to each interfacing material supplier.
  5. Provide large scale isometric drawings of all sheet metal and trim intersections and transitions, include all fastener locations and materials, cleats and other miscellaneous accessories necessary to complete the work as specified.
- D. Sustainable Design Submittals:
1. Environmental Materials Reporting Form (EMRF) Recycled Content. Provide the following information:
    - a. Name of Product and Manufacturer.
    - b. Material cost breakdowns. Cost breakdowns must include total material-only cost (excluding installation, labor and equipment).



## GENERAL SPECIFICATION 07620 - SHEET METAL FLASHING AND TRIM

---

- c. The percentage (by weight) of post-consumer and pre-consumer recycled content in the submitted product(s), if applicable.

### 1.08 DELIVERY, STORAGE AND HANDLING

#### A. Delivery of Materials:

- 1. Deliver materials in manufacturers' original, unopened and undamaged containers and rolls, with labels intact and legible and with information accurately representing container contents as approved by Engineer at time of Shop Drawing submission.
- 2. Items delivered in broken, damaged, rusted, or unlabeled condition shall immediately be removed from project site and not offered again for approval by Engineer.

#### B. Storage of Materials:

- 1. Store materials in an area protected from all construction traffic not associated with the work of this Section.
- 2. Store materials off the ground and in same package in which they were shipped, and on platforms protected from dirt and other contamination.
- 3. Store under cover and in a manner which does not permit water to remain on units.

#### C. Handling of Materials:

- 1. Protect all sheet metal flashing and trim work from dents, scratches, warps and bends.
- 2. Immediately after installation of each system component, remove all strippable protective films.
- 3. Comply with manufacturer's instructions for handling and installation of the ribbed metal cavity wall flashing materials, except where more stringent requirements are shown or specified.

### 1.09 PROJECT CONDITIONS

#### A. Protection:

- 1. Provide continuous protection of materials against damage primarily by storing materials under cover and above ground and away from all construction traffic.
- 2. Provide continuous protection of materials against wetting and contamination.

## GENERAL SPECIFICATION 07620 - SHEET METAL FLASHING AND TRIM

---

### B. Scheduling:

1. Coordinate ribbed metal cavity wall flashings with other Work to ensure secure anchorage and watertight seals, and to minimize exposure to puncture or other damage from the work of other trades. Refer to General Specifications 04200 - Unit Masonry and 07501 - Single-Ply Roofing System.
2. Deliver materials to the site in sufficient quantities to ensure uninterrupted progress of the Work.
3. Do not proceed with the sheet metal flashing and trim Work until curb and substrate construction, blocking, and other construction to receive the Work is completed.
4. Schedule the installation of sheet metal flashing and trim Work to coincide with the installation of roofing, waterproofing, drains, piping, blocking, nailers, framing at openings, curbs, unit masonry and other adjoining and substrate work.
5. Proceed with and complete the work only when materials, equipment and knowledgeable tradesmen required for the installation of sheet metal flashing and trim systems are at the site and are ready to follow and integrate the work of this Section with work requiring the installation of sheet metal flashing and trim.

### 1.10 WARRANTY

- A. Contractor shall execute his own written guarantee direct to the City warranting all roof sheet metal flashing and trim as weather and watertight and perfect for a period of two years after date of conditional acceptance thereof by the City. Imperfections, by reason of defective materials, workmanship or arrangement of the various parts shall be made good to the satisfaction of the City at Contractor's expense.
- B. In addition to above Contractor shall provide the City with manufacturer's standard warranty for sheet metal flashing and trim.

## PART 2 PRODUCTS

### 2.01 MANUFACTURERS

- A. Through-Wall Ribbed Sheet Metal Flashing (Stainless Steel):
  1. Cheney Flashing Company, Inc.; Cheney Flashing (Dovetail) – Trenton, NJ.
  2. Cheney Flashing Company, Inc.; Cheney Flashing (Sawtooth) - Trenton, NJ.

**GENERAL SPECIFICATION 07620 - SHEET METAL FLASHING AND TRIM**

---

3. Or approved equal.
- B. Reglets:
1. Cheney Flashing Company, Inc., Trenton, NJ.
  2. Or approved equal
- 2.02 MATERIALS
- A. Stainless Steel Flashings Associated with Single-Ply Roofing:
1. Provide through-wall sheet metal flashing for embedment in masonry with ribs at 3-inch intervals along length of flashing to provide an integral mortar bond.
  2. Provide sheet stainless steel, Type 316 complying with ASTM A666, with No. 2D dead soft, fully annealed finish, unless required to be harder temper for proper forming and performance for application indicated.
  3. Provide thickness of 0.0156 inch.
  4. Provide stainless steel flashing and counterflashing at penetrations in single- ply roofing.
- B. Interlocking Mechanically-Keyed, Ribbed Stainless Steel Flashing & Counterflashing System Associated with Unit Masonry:
1. Provide deformed sheet, stainless steel, Type 316 complying with ASTM A666 for all Work with No. 2D finish.
  2. For flashing within unit masonry wall system, through-wall flashing at spandrels and horizontal steel and concrete members in walls provide flashing with a mechanically-keyed, 3-way sawtooth design, which bonds in all directions and which has weephole drainage at 3 inch intervals.
  3. Provide a complete system of interlocking, mechanically-keyed components all by the same manufacturer including, but not limited to, cast-in-place mechanically-keyed and built-in-place mechanically-keyed masonry-reglets, through-wall metal masonry counterflashing and metal through-wall base flashing, and in other locations shown.
  4. Thickness: Provide thickness of 26 gauge (0.018-inches).
- C. Reglets: Units of type, material, and profile indicated, formed to provide secure interlocking of separate reglet and counterflashing pieces, and compatible with flashing indicated with factory- mitered and -welded corners and junctions.
1. Material: Stainless steel, 0.0187 inch thick.

## GENERAL SPECIFICATION 07620 - SHEET METAL FLASHING AND TRIM

---

2. Select reglet types required from subparagraphs below.
  3. Surface-Mounted Type: Provide with slotted holes for fastening to substrate, with neoprene or other suitable weatherproofing washers, and with channel for sealant at top edge.
  4. Stucco Type: Provide with upturned fastening flange and extension leg of length to match thickness of applied finish materials.
  5. Concrete Type: Provide temporary closure tape to keep reglet free of concrete materials, special fasteners for attaching reglet to concrete forms, and guides to ensure alignment of reglet section ends.
  6. Masonry Type: Provide with offset top flange for embedment in masonry mortar joint.
  7. Flexible Flashing Retainer: Provide resilient plastic or rubber accessory to secure flexible flashing in reglet where clearance does not permit use of standard metal counterflashing or where Drawings show reglet without metal counterflashing.
  8. Counterflashing Wind-Restraint Clips: Provide clips to be installed before counterflashing to prevent wind uplift of counterflashing lower edge.
- D. Miscellaneous Materials:
1. Solder for Stainless Steel: ASTM B32, Lead-free; 96.5% Sn, 3.45% Cu, 1% Sb, 0.05% Ag used with an acid flux of the type recommended by the stainless steel manufacturer. Use a non-corrosive rosin flux over tinned surfaces.
  2. Stainless Welding Rods: Type recommended by stainless steel sheet manufacturer for the type of metal sheets furnished.
  3. Nails, Screws and Rivets: Same material as flashing sheet, or as recommended by manufacturer of flashing sheet.
  4. Cleats: Same metal and gage as sheet being anchored, 2-inches wide, punched for two anchors.

### 2.03 FABRICATION

- A. Fabricated Metal Flashing and Trim: Shop fabricate sheet metal flashing and trim to comply with profiles and sizes shown, and to comply with manufacturer's recommended details. Except as otherwise shown or specified, provide soldered flat-lock seams, and fold back metal to form a hem on the concealed side of exposed edges. Comply

## GENERAL SPECIFICATION 07620 - SHEET METAL FLASHING AND TRIM

---

with metal producers' recommendations for tinning, soldering and cleaning flux from metal.

- B. On all metal base and counterflashing, and trim provide completely shop-fabricated corners and special flashings; heliarc welded to insure watertight joints. Grind welds smooth so as to be indistinguishable from adjacent surfaces.

### PART 3 EXECUTION

#### 3.01 EXAMINATION

- A. The Contractor shall examine the substrate and the conditions under which the sheet metal flashing and trim work is to be performed, and notify Engineer in writing of unsatisfactory conditions. Do not proceed with the work until unsatisfactory conditions have been corrected in a manner acceptable to Engineer.

#### 3.02 PREPARATION

- A. Clean the substrate of dust, debris, substances and interferences detrimental to the Work and prepare substrates as recommended by the sheet metal manufacturer.
- B. Before installing flashing and trim, verify shapes, and dimensions to be covered.

#### 3.03 INSTALLATION

- A. General:
  - 1. Separate dissimilar metals from substrates and from each other by painting each metal surface in the area of contact with a 15-mil thick application of bituminous coating, as recommended by the manufacturers of the dissimilar metals. Comply with manufacturer's recommendations for other forms of protection of the stainless steel and aluminum against corrosion.
  - 2. Provide thermal expansion for running trim, flashing and other items exposed for more than 15 feet - 0 inch continuous length. Maintain a watertight installation at expansion seams. Locate expansion seams at 15 feet - 0 inch intervals, and 2 feet - 0 inch each side of corners and intersections.
  - 3. Fabricate and install the work with lines and corners of exposed units true and accurate. Form exposed faces flat and free of buckles, excessive waves and avoidable tool marks, considering the temper and reflectivity of the metal. Provide uniform, neat double-locked seams with cleats rolled into the seam and with minimum exposure of solder, welds and sealant. Except as

## GENERAL SPECIFICATION 07620 - SHEET METAL FLASHING AND TRIM

---

otherwise shown, fold back the sheet metal to form a hem on the concealed side of exposed edges. All exposed edges of all sheet metal flashing shall be hemmed not less than 1/2-inch wide.

4. Conceal fasteners and expansion provisions wherever possible in exposed work, and locate so as to minimize the possibility of leakage. Cover and seal work as required for a watertight installation.
  5. Provide cleat-type anchorages for metal flashings and trim wherever practical, arranged to relieve stresses from building movement, and thermal expansion and contraction.
  6. On vertical surfaces lap 2-piece flashings a minimum of 4 inches.
  7. On sloping surfaces, for slopes of not less than 6 inches in 12 inches, lap unsealed flashings a minimum of 6 inches. For slopes less than 6 inches in 12 inches use soldered flat-locked seams.
  8. For embedment of metal flashing flanges in single ply roofing or flashing or stripping, extend flanges for a minimum of 6 inches embedment.
  9. Flashing to be inserted into reglets shall be installed to the full depth of the reglet with the top flange of the flashing edge turned forward to form a hook. Caulk flashing into reglets using stainless steel wedges. Fill reglet with sealant specified in General Specification 07900 - Caulking and Sealants.
- B. Installation of Stainless Steel Flashing and Trim:
1. Tin the edges of plain stainless steel to be soldered, for a width of 1-1/2 inches, using solder for stainless steel and acid flux. Remove every trace of acid flux residue from the metal promptly after tinning or soldering.
  2. Provide welded joints. Provide upturned, 1/2-inch wide hooked flanges, and weld between adjoining sheets; lay seam flat.
- C. Installation of Ribbed Metal Cavity Wall Flashing:
1. Build ribbed metal through-wall masonry flashing work into unit masonry construction as construction work progresses. Work performed without built-in flashings shall be stopped, removed and rebuilt at no additional expense to the City, even if discovered only after walls and other materials are in-place and completed.

## **GENERAL SPECIFICATION 07620 - SHEET METAL FLASHING AND TRIM**

---

2. Install all flashings in a split bed of mortar, increasing the thickness of the bed if required to achieve full mortar coverage on top and bottom of flashings.
3. Coordinate the installation of flashing materials and associated work so as to provide a complete system complying with the combined recommendations of manufacturers and installers involved in the work.
4. Use only installation techniques approved by the ribbed metal cavity wall flashing manufacturer.

### **3.04 FIELD QUALITY CONTROL FOR CAVITY WALL FLASHING**

- A. Field test ribbed metal cavity wall flashing after installation. After building three courses of unit masonry above area of ribbed cavity wall flashing, tape weep vents closed and fill cavity with water.
- B. Water leaking from the wall below the area of the ribbed metal cavity wall flashing shall be evidence that the ribbed metal cavity wall flashing has been improperly installed.
- C. Remove unit masonry and improperly installed ribbed cavity wall flashing and install new ribbed cavity wall flashing. Repeat this process until the wall does not show evidence of leakage beneath ribbed cavity wall flashing. All such remedial work shall be at no additional expense to the City.
- D. Remove tape from weep vents and all mortar and other debris from cavity and demonstrate free flow of water from the cavity at conclusion of test.

### **3.05 ADJUSTMENT AND CLEANING**

- A. Protect sheet metal flashing and trim work until Final Acceptance of the work.
- B. Do not permit workmen, or others, to step directly on flashing sheets in place, or to place or move equipment over flashing and trim surfaces. Protect surfaces during installation of permanent covering work and adjoining work.
- C. Neutralize excess flux as work progresses with five percent to ten percent washing soda solution and rinse thoroughly.
- D. Clean exposed surfaces of every substance which is visible or might cause corrosion or prevent uniform oxidation of the metal surfaces. Exercise extreme care to remove fluxes and ferrous metal particles, including welding splatter and grinding dust.

**GENERAL SPECIFICATION 07620 - SHEET METAL FLASHING AND  
TRIM**

---

- E. Do not leave metal debris and discarded materials at the site of the work.  
Clean each site of the work as the work progresses on a daily basis.

END OF SECTION



**SECTION 07621  
Gutters and Downspouts**

**PART 1 GENERAL**

**1.01 SUMMARY**

- A. Gutters and downspouts as specified herein include, but are not limited to, prefabricated gutters, downspouts, scuppers, collection boxes, flashing, sealants and bonding agents between the components of this Section, and appurtenances.
- B. Gutters and downspouts shall be provided as indicated on the Contract Drawings, specified herein or in the Detailed Specifications, or as required for a complete installation.
- C. The Contractor shall implement practices and procedures to meet the project’s sustainability goals as identified in the Contract Documents. The Contractor shall ensure that the sustainability requirements of this Section are implemented to the fullest extent.
- D. The following index of this Section is presented for convenience:

<u>Article</u>	<u>Title</u>	<u>Page</u>
		07621-
PART 1	General.....	1
1.01	Summary.....	1
1.02	Payment.....	2
1.03	Related Sections.....	2
1.04	References.....	2
1.05	System Design Requirements.....	2
1.06	Quality Assurance.....	3
1.07	Submittals.....	4
1.08	Delivery, Storage And Handling.....	4
1.09	Warranty.....	5
PART 2	PRODUCTS.....	5
2.01	Manufacturers.....	5
2.02	Materials.....	5
PART 3	EXECUTION.....	6
3.01	Examination.....	6
3.02	Preparation.....	6
3.03	Installation.....	6
3.04	Protection.....	7
3.05	Adjustment.....	7
3.06	Cleaning.....	7

## **GENERAL SPECIFICATION 07621 – GUTTERS AND DOWNSPOUTS**

### 1.02 PAYMENT

- A. No separate payment will be made for performing any work of this Section; all costs for this work shall be included in the lump sum price bid for the Contract, except as provided for in the Detailed Specifications

### 1.03 RELATED SECTIONS

- A. General Specification 05081 -- Galvanizing
- B. General Specification 09900 -- Painting

### 1.04 REFERENCES

- A. ASTM A480 -- Standard Specification for General Requirements for Flat-Rolled Stainless and Heat-Resisting Steel Plate, Sheet, and Strip
- B. ASTM A653 -- Standard Specification for Steel Sheet, Zinc-Coated (Galvanized) or Zinc-Iron Alloy Coated (Galvannealed) by the Hot Dip Process
- C. ASTM B209 -- Standard Specification for Aluminum and Aluminum- Alloy Sheet and Plate
- D. ASTM B221 -- Standard Specification for Aluminum and Aluminum Alloy Extruded Bars, Rods, Wire, Profiles, and Tubes
- E. ASTM B370 -- Standard Specification for Copper Sheet and Strip for Building Construction
- F. SMACNA -- Sheet Metal and Air Conditioning Contractors National Association, Incorporated, Architectural Sheet Metal Manual
- G. SPRI -- Single Ply Roofing Industry, Wind Design Guide for Use with Low Slope Roofing

### 1.05 SYSTEM DESIGN REQUIREMENTS

- A. The products provided by this Section shall include the following:
  - 1. Prefabricated gutters, collection boxes, scuppers, and downspouts formed to profiles, constructed of materials, and

## **GENERAL SPECIFICATION 07621 – GUTTERS AND DOWNSPOUTS**

---

installed as shown on the Contract Drawings and specified in the Detailed Specifications.

2. Accessories and items essential for the completeness of the installation shall be the same kind of material as the item to which applied.
3. Materials shall be manufactured and delivered from manufacturing locations that are closest to the project site to reduce transportation cost and emissions.
4. Sustainable Design Requirements:
  - a. Recycled Content of Steel Sheet Metal: Postconsumer recycled content plus one-half of preconsumer recycled content shall not be less than 25 percent.
  - b. Recycled Content of Aluminum Sheet Metal and Extrusions: Postconsumer recycled content plus one-half of preconsumer recycled content shall not be less than 25 percent.
5. Project-specific system description or design requirements for the work of this Section will be provided in the Detailed Specifications, if necessary, to supplement the requirements given herein or in the Contract Drawings.

### **1.06 QUALITY ASSURANCE**

- A. The workmanship of sheet metal work, method for forming joints, anchoring, cleating, and provisions for expansion shall conform to the standard details and recommendations of the Copper Development Association and the Architectural Sheet Metal Manual published by SMACNA. Workmanship shall be in accordance with the best trade practice and recommendations and specifications of the Sheet Metal and Air Conditioning Contractors National Association, Incorporated.
  1. Uplift requirements shall match the requirements for adjacent membrane roofing as specified in the Detailed Specifications.
  2. Wind resistance calculation shall be designed specifically for this project. The Contractor shall calculate and certify that the perimeter metal edge systems furnished meet the anticipated design pressure as specified in the Detailed Specifications when tested in accordance with SPRI Test Methods RE-2 and RE-3.
- B. The forming and assembling of sheet metal components shall be performed using methods that will not void any manufacturer's warranty.

## **GENERAL SPECIFICATION 07621 – GUTTERS AND DOWNSPOUTS**

### 1.07 SUBMITTALS

A. The Contractor shall submit Shop Drawings for approval of the Engineer. Submittals shall include, but not be limited to:

1. Product Data: The Contractor shall submit
  - a. Copies of specifications, installation instructions and general recommendations from the gutter and downspout system manufacturer.
  - b. Manufacturer's data substantiating that the materials comply with the requirements shall be included.
2. Shop Drawings: Shop Drawings shall show layout, profiles, methods of joining, and methods of attachment and anchorage for the gutter and downspout system.
3. Samples: The Contractor shall submit
  - a. Three 12-inch long samples of factory fabricated products, including the finish specified in the Detailed Specifications.
4. Sustainable Design Submittals:
  - a. Environmental Materials Reporting Form (EMRF) Recycled Content.
    - 1) Provide the following information:
    - 2) Name of Product and Manufacturer.
    - 3) Material cost breakdowns. Cost breakdowns must include total material-only cost (excluding installation, labor and equipment).
    - 4) The percentage (by weight) of post-consumer and pre-consumer recycled content in the submitted product(s), if applicable.

### 1.08 DELIVERY, STORAGE AND HANDLING

A. Delivery of Materials:

1. Materials shall not be delivered to the project site before the time of installation.
2. Materials shall be delivered in sufficient quantities to allow continuity of the Work.

B. Storage of Materials:

1. Materials shall be stored in original, undamaged containers with manufacturer's labels and seals intact.

## **GENERAL SPECIFICATION 07621 – GUTTERS AND DOWNSPOUTS**

---

2. All materials shall be stored in a dry, enclosed area, out of direct sunlight, off the ground and away from all possible contact with water, ice, or snow.
  3. Damage to materials during storage shall be prevented primarily by minimizing the amount of time they are stored at the site before being incorporated into construction systems.
- C. Handling of Materials:
1. Materials shall be handled carefully in order to avoid damage or breakage.
  2. Materials shall not be exposed to detrimental conditions or physical damage. Materials which are so exposed shall be permanently removed from the site and shall not be incorporated into the Work.
  3. Packages or containers shall not be opened until all necessary, preparatory Work is complete and installation is to begin immediately. Materials shall not be allowed to become wet or soiled or covered with ice or snow.

### 1.09 WARRANTY

- A. Contractor shall execute his own written guarantee direct to the City warranting all gutters and downspouts for a period of two years after date of conditional acceptance thereof by the City. Imperfections, by reason of defective materials, workmanship or arrangement of the various parts shall be made good to the satisfaction of the City at Contractor's expense.
- B. In addition to above Contractor shall provide the City with manufacturer's standard warranty for gutters and downspouts.

## PART 2 PRODUCTS

### 2.01 MANUFACTURERS

- A. Gutter and downspout manufacturer shall be as specified in the Detailed Specifications.

### 2.02 MATERIALS

- A. General: Gutter and downspout system shall comprise materials from one manufacturer. Material and profiles of the gutter and downspout system shall be as specified in the Detailed Specifications. Specified materials shall meet the following minimum requirements.
- B. Aluminum Extrusions: Alloy and temper of aluminum extrusions shall be as recommended by the manufacturer for the use intended, and as required for proper application of finish specified, but not less than the

## **GENERAL SPECIFICATION 07621 – GUTTERS AND DOWNSPOUTS**

strength and durability properties specified in ASTM B221 for 6063-T6.

- C. Aluminum Sheet: Alloy and temper of aluminum sheet be as recommended by the manufacturer for the use intended, and as required for proper application of finish specified, but not less than the strength and durability properties specified in ASTM B209 for 5005-H15.
- D. Galvanized sheet metal shall be in accordance with the requirements of ASTM A653 and General Specification 05081 - Galvanizing, and shall be a minimum 20 gauge thickness. Galvanized sheet metal shall be mill phosphatized where shown or specified to be painted.
- E. Stainless steel shall be AISI Type 302/304, in compliance with ASTM A480, and shall be a minimum of 28 gauge thickness. Finish shall be as specified in the Detailed Specifications.
- F. Copper shall be in conformance with ASTM B370, minimum 16 oz., and shall have a temper of H00 (cold-rolled) except where temper 060 is required for forming.
- G. Gutter and Downspout System: Gutters, downspouts, collection boxes, and/or scuppers shall be factory fabricated to configurations indicated on the Contract Drawings. Gutter straps, support brackets, elbows, fittings, drain bars, and appurtenances shall be factory fabricated for their intended use. Gutters shall be fabricated with expansion joints at a maximum of 48 feet on center. Gutter straps and/or support brackets shall be installed at a minimum of 30 inches on center.

### **PART 3 EXECUTION**

#### **3.01 EXAMINATION**

- A. The Contractor shall verify that areas to receive gutters and downspouts are properly prepared and completed to final elevations.

#### **3.02 PREPARATION**

- A. Dissimilar metals shall be separated from each other by painting each metal surface in contact with a coating as specified in General Specification 09900 - Painting.

#### **3.03 INSTALLATION**

- A. Gutters and downspouts shall be installed in strict accordance with the manufacturer's instructions and recommendations, and in compliance with the SMACNA Architectural Sheet Metal Manual.
- B. Gutter and downspout work shall be watertight and weather-tight with all lines, arrises and angles sharp and true. Plain surfaces shall be free from waves and buckles.

## **GENERAL SPECIFICATION 07621 – GUTTERS AND DOWNSPOUTS**

- C. Outlets and end caps shall be placed where shown on the Contract Drawings, and shall be installed in accordance with the manufacturer's instructions and recommendations.

### 3.04 PROTECTION

- A. All components of the Work shall be protected from damage until construction operations are completed and acceptable to Engineer.
- B. Work which cannot, for reasons acceptable to Engineer, be completed before the onset of weather detrimental to the Work shall be completely protected in such a manner as to deflect water and weather from the installation without damaging adjacent Work.
- C. Gutters and downspouts shall be protected from all damage and abuse from all other Contractors and installers involved in the Work until Final Acceptance by the City.

### 3.05 ADJUSTMENT

- A. System components which are dislodged, damaged, expanded, or penetrated by subsequent installation operations or damaged by detrimental weather shall be immediately replaced with undamaged material in compliance with the Sections and properly protected as specified.

### 3.06 CLEANING

- A. Exposed metal surfaces shall be cleaned using materials and processes as recommended by the manufacturer.

END OF SECTION

**GENERAL SPECIFICATION 07621 – GUTTERS AND DOWNSPOUTS**

NO TEXT ON THIS PAGE



**SECTION 07900  
Caulking and Sealants**

**PART 1 GENERAL**

**1.01 SUMMARY**

- A. This Section describes the general requirements for caulking and sealant systems for openings and joints in building roofs and walls between concrete-in-place, masonry units, metal roof flashing, and other equipment and structures in order to provide a positive barrier against the passage of air and moisture.
- B. Complete technical services from the approved caulking and sealant manufacturers and on-site technical representation by their Technical Representatives during the time of delivery, storage and installation of the work of this Section and during other work which may affect the work of this Section as specified herein is also included.
- C. The Contractor shall provide all labor, materials, equipment and incidentals necessary to perform the work of this Section as shown on the Contract Drawings, specified herein or in the Detailed Specifications, or required otherwise for a complete job.
- D. The Contractor shall implement practices and procedures to meet the project's sustainability goals as identified in the Contract Documents. The Contractor shall ensure that the sustainability requirements of this Section are implemented to the fullest extent.
- E. The following index of this Section is presented for convenience:

<u>Article</u>	<u>Title</u>	<u>Page</u>
		07900-
PART 1	GENERAL .....	1
1.01	Summary .....	1
1.02	Payment.....	2
1.03	References.....	2
1.04	System Design Requirements .....	2
1.05	Quality Assurance.....	3
1.06	Submittals .....	4
1.07	Delivery, Storage And Handling.....	5
1.08	Project Conditions.....	6
1.09	Warranty .....	7
PART 2	PRODUCTS.....	7
2.01	Manufacturers .....	7
2.02	Materials .....	7

**GENERAL SPECIFICATION 07900 -- CAULKING AND SEALANTS**

---

2.03	Mixing.....	9
PART 3	EXECUTION.....	9
3.01	Examination .....	9
3.02	Joint Surface Preparation .....	9
3.03	Installation.....	10
3.04	Field Quality Control .....	11
3.05	Adjustment And Cleaning.....	12
1.02	PAYMENT	
A.	No separate payment will be made for performing any work of this Section and all costs thereof shall be included in the lump sum price bid for the Contract, except as provided for in the Detailed Specifications.	
1.03	REFERENCES	
A.	NYCBC	-- New York City Building Code
B.	ASTM C510	-- Staining and Color Change of Single or Multi component Joint Sealers, Standard Test Method for
C.	ASTM C661	-- Indentation Hardness of Elastomeric-Type Sealants by Means of a Durometer, Standard Test Method for
D.	ASTM C793	-- Effects of Laboratory Accelerated Weathering on Elastomeric Joint Sealants, Standard Test Method for
E.	ASTM C794	-- Adhesion-in-Peel of Elastomeric Joints Sealants, Standard Test Method for
F.	ASTM C920	-- Elastomeric Joint Sealants, Standard Specification for
G.	ASTM C1247	-- Sealants Exposed To Continuous Immersion In Liquids, Standard Test Method for
1.04	SYSTEM DESIGN REQUIREMENTS	
A.	Description:	
1.	The caulking and sealant systems to be furnished under the work of this Section shall include two-part elastomeric sealants,	

components, accessories and miscellaneous materials used for sealing joints in horizontal and vertical planes.

2. The Work shall include but is not limited to:
  - a. all joints between cast-in-place concrete and masonry;
  - b. all cast-in-place concrete to cast-in-place concrete expansion joints;
  - c. all joints between masonry and metal;
  - d. all control joints in masonry and concrete;
  - e. all isolation joints between equipment and other items; and
  - f. joints where construction systems are discontinuous or inherently non-watertight.
3. The Work shall be performed at all locations whether or not indicated required to render the building watertight except where a construction system is specifically specified or shown as not relying upon the use of sealants in order to achieve weather- and water tightness.

**B. Substitutions**

1. Do not change products, system components, colors or manufacturers after Shop Drawing and Samples approvals by Engineer.
2. Clearly identify, in a manner which is highlighted to Engineer, all proposed substitutions, modifications, variations, unspecified features and "or equal" products. Provide complete comparative data with specified products at time of Shop Drawing submission.

**C. Sustainable Design Requirements**

1. Low Emitting Materials: Sealants and sealant primers used on site and within the building's weatherproofing system shall comply with the following limits for VOC content:
  - a. Architectural Sealants: 250 g/L.
  - b. Sealant Primers for Nonporous Substrates: 250 g/L.
  - c. Sealant Primers for Porous Substrates: 775 g/L.

**1.05 QUALITY ASSURANCE**

1. Engage a single manufacturer who shall provide the services of a Technical Representative who shall assist Contractor and

## GENERAL SPECIFICATION 07900 -- CAULKING AND SEALANTS

---

Engineer by providing technical opinions on the adequacy of materials and methods of installation based on Shop Drawings approved by Engineer.

- a. Provide such services during the time of delivery, storage, handling and installation of all caulking and sealant system components.
2. Test caulking and sealants for compatibility with the substrates specified for conformance to current industry standards, and recommend remedial procedures as required.
- B. Installer Qualifications: Engage a single installer skilled, trained and with successful experience in the application of the types of material required and who agrees to employ only tradesmen with specific skill and successful experience in this type of work.
- C. Performance Criteria: Do not provide exposed caulking and sealant work for metal batten roofing, sheet metal flashing and trim or custom preformed metal siding work in order to render the work watertight. These construction systems shall be detailed, fabricated and provided such that they are inherently watertight without the use of additional caulking, sealant, elastomeric compounds, asphaltic compounds or other similar materials.
- D. Compatibility: Before purchase of each specified sealant, investigate its compatibility with the joint surfaces, joint fillers and other materials in the joint system. Provide only materials (manufacturer's recommended variation of the specified materials) which are known to be fully compatible with the actual installation condition, as shown by manufacturer's published data or certification.

### 1.06 SUBMITTALS

- A. Contractor shall submit Shop Drawings for approval of the Engineer. Submittals shall include, but not be limited to:
  1. Samples: Submit for approval the following:
    - a. Actual cured material samples of each type of caulking and sealant specified, 4-inches long, in each of the manufacturer's standard colors.
    - b. Samples will be reviewed by Engineer for color and texture only.
    - c. Compliance with other requirements is the responsibility of Contractor.
- B. Shop Drawings: Submit for approval the following:

1. Copies of manufacturer's specifications, recommendations and installation instructions for each type of sealant, caulking compound and associated miscellaneous material required. Include manufacturer's published data, indicating that each material complies with the requirements and is intended for the applications shown.
2. Test Reports: Submit for approval the following:
  - a. Compatibility tests for substrates, based on adhesion-in-peel standard test procedures and ASTM C920.
  - b. Copies of certified laboratory test reports indicating conformance with the requirements specified.
3. Guarantee: Submit for approval:
  - a. Copies of written guarantee agreeing to repair or replace sealants which fail to perform as specified.
4. Sustainable Design Submittals:
  - a. Environmental Materials Reporting Form (EMRF) Recycled Content. Provide the following information:
    - 1) Name of Product and Manufacturer.
    - 2) Material cost breakdowns. Cost breakdowns must include total material-only cost (excluding installation, labor and equipment).
    - 3) The percentage (by weight) of post-consumer and pre-consumer recycled content in the submitted product(s), if applicable.
5. VOC Reporting Form. Provide the following information:
  - a. For all sealants and sealant primers used on site and within the building's weatherproofing system provide the VOC content in grams/Liter (g/L) less water and other exempt compounds.

1.07 DELIVERY, STORAGE AND HANDLING

A. Delivery of Materials:

1. Deliver materials in caulking and sealant manufacturer's original unopened and undamaged containers, with information accurately representing container contents as approved by Engineer at time of Shop Drawing and Samples submissions.
2. Include the following information on the label:

## GENERAL SPECIFICATION 07900 -- CAULKING AND SEALANTS

---

- a. Name of material and supplier.
  - b. Formula or specification number, lot number, color and date of manufactures.
  - c. Mixing instructions, shelf life and curing time when applicable.
3. Failure to comply with these requirements shall be sufficient cause for rejection of the material in question, by Engineer, and his requiring its removal from the site. Supply new material conforming to the specified requirements at no additional expense to the City.
- B. Storage of Materials:
1. Store materials so as to preclude foreign materials.
  2. Do not store or expose materials to temperature above 90 F or store in direct sunshine.
  3. Do not use materials which are outdated as indicated by shelf life.
  4. Store sealant tape in a manner which will not deform the tape.
  5. In cool or cold weather store containers where temperature approximates 75°F for 16 hours before using.
  6. When high temperatures prevail store mixed sealants in a cool place.
- C. Handling:
1. Handle materials carefully to prevent inclusion of foreign materials.
  2. Do not open containers or mix components until necessary preparatory work and priming has been completed.
- 1.08 PROJECT CONDITIONS
- A. Environmental Conditions:
1. Do not proceed with installation of caulking and sealants under adverse weather conditions, or when temperatures are below or above manufacturer's recommended limitations for installation.
  2. Proceed with the work only when forecasted weather conditions are favorable for proper cure and development of high early bond strength.
  3. Wherever joint width is affected by ambient temperature variations, install elastomeric sealants only when temperatures are in

the lower third of manufacturer's recommended installation temperature range, so that sealant will not be subjected to excessive elongation and bond stress at subsequent low temperatures.

4. When high temperatures prevail avoid mixing sealants in direct sunlight.

B. Protection: Do not allow caulking and sealants to overflow or spill onto adjoining surfaces, or to migrate into the voids of adjoining surfaces including rough textured materials. Use masking tape or other precautionary devices to prevent staining of adjoining surfaces, by either the primer/sealer or the caulking and sealant materials.

#### 1.09 WARRANTY

A. Provide a written guarantee agreeing to repair or replace sealants which fail to perform as air-tight and watertight joints; or fail in joint adhesion, cohesion, abrasion resistance, weather resistance, extrusion resistance, migration resistance, stain resistance, or general durability; or appear to deteriorate in any other manner not clearly specified by submitted manufacturer's data, as an inherent quality of the material for the exposure indicated. Provide guarantee signed by the installer and Contractor. Provide guarantee period of two years.

### PART 2 PRODUCTS

#### 2.01 MANUFACTURERS

A. Exterior and Interior Joints in Vertical Planes: Provide one of the following:

1. Dymeric 240FC as manufactured by Tremco Incorporated, an RPM Company, Beachwood, OH.
2. Sikaflex-2C NS by Sika Corporation, Lindhurst, NJ.
3. Or approved equal.

B. Exterior and Interior Joints in Horizontal Planes: Provide one of the following:

1. - THC 900/ 901 by Tremco Incorporated, an RPM Company, Beachwood, OH.
2. Sikaflex-2C SL by Sika Corporation, Lindhurst, NJ.
3. Or approved equal.

#### 2.02 MATERIALS

A. Exterior and Interior Joints in Vertical Planes:

## GENERAL SPECIFICATION 07900 -- CAULKING AND SEALANTS

---

1. Urethane-based, two-component elastomeric sealant complying with the following:
  - a. ASTM C 920 Adhesion-in-Peel, ASTM C 920 and ASTM C 794: Minimum 10 lbs/linear inch with no adhesion failure.
  - b. Hardness (Standard Conditions), ASTM C 661: 20-25 (Shore A).
  - c. Stain and color change, ASTM C 920 and ASTM C 510: No discoloration or stain.
  - d. Accelerated Aging, ASTM C 793: No change in sealant characteristics after 250 hours in weatherometer.
  - e. Rheological Vertical Displacement at 120 F, ASTM C 920: No sag.
- B. Exterior and Interior Joints in Horizontal Planes:
  1. Polyurethane-based, two-component elastomeric sealant complying with the following:
    - a. ASTM C 920 Water Immersion Bond, ASTM C 1247: Elongation of 25% with no adhesive failure.
    - b. Hardness (Standard Conditions), ASTM C 661: 30-40.
    - c. Stain and Color Change, ASTM C 1247 and ASTM C 510: No discoloration or stain.
    - d. Accelerated Aging, ASTM C 793: No change in sealant characteristics after 250 hours in weatherometer.
- C. Provide colors selected by Engineer from caulking and sealant manufacturer's standard color charts. Engineer will select a maximum of ten colors for the Work. Manufacturers supplying sealants other than those specified above must provide the same colors available from those specified.
- D. Miscellaneous Materials:
  1. Joint Cleaner: Provide the type of joint cleaning compound recommended by the sealant and caulking manufacturer, for the joint surfaces to be cleaned.
  2. Joint Primer and Sealer: Provide the type of joint primer and sealer recommended by the caulking and sealant manufacturer, for the joint surfaces to be primed or sealed.
  3. Bond Breaker Type: Polyethylene tape or other plastic tape as recommended by the caulking and sealant manufacturer, to be



applied to sealant-contact surfaces where bond to the substrate or joint filler must be avoided for proper performance of caulking and sealant. Provide self-adhesive tape wherever applicable.

4. Sealant Backer Rod: Compressible rod stock polyethylene foam, polyethylene jacketed polyurethane foam, butyl rubber foam, neoprene foam or other flexible, permanent, durable nonabsorptive material as recommended for compatibility with caulking and sealant by the caulking and sealant manufacturer. Provide size and shape of rod which will control the joint depth for sealant placement, break bond of sealant at bottom of joint, form optimum shape of sealant bead on back side, and provide a highly compressible backer to minimize the possibility of sealant extrusion when joint is compressed.
5. Low Temperature Catalyst: Provide the type recommended by the caulking and sealant manufacturer.

2.03 MIXING

- A. Comply with sealant manufacturer's written instructions for mixing 2-component sealants.
- B. Thoroughly mix components before use.
- C. Add entire contents of activator can to base containers. Do not mix partial units.
- D. Mix contents for a minimum of 5 minutes or as recommended by the sealant manufacturer, until color and consistency are uniform.

PART 3 EXECUTION

3.01 EXAMINATION

- A. The Contractor shall examine the joint surfaces, substrates, backing, and anchorage of units forming sealant rabbet, and the conditions under which the caulking and sealant work is to be performed, and notify Engineer in writing of any condition detrimental to the proper and timely completion of the Work and the performance of the sealant systems. Do not proceed with the caulking and sealant work until unsatisfactory conditions have been corrected in a manner acceptable to Engineer.

3.02 JOINT SURFACE PREPARATION

- A. Clean joint surfaces immediately before installation of sealant compound. Remove dirt, insecure coatings, moisture and other substances

- which would interfere with bonds of sealant compound as recommended by sealant manufacturer's written instructions.
- B. Etch concrete and masonry joint surfaces to remove excess alkalinity, unless sealant manufacturer's written instructions indicate that alkalinity does not interfere with sealant bond and performance.
    - 1. Etch with 5 percent solution of muriatic acid.
    - 2. Neutralize with dilute ammonia solution.
    - 3. Rinse thoroughly with water and allow to dry before sealant installation.
  - C. If necessary, clean porous materials such as concrete and masonry by grinding, abrasive blasting or mechanical abrading. Blow out joints with oil-free compressed air, or by vacuuming joints prior to application of primer or sealant.
  - D. Roughen joint surfaces on vitreous coated and similar non-porous materials, wherever sealant manufacturer's data indicates lower bond strength than for porous surfaces. Rub with fine abrasive cloth or wool to produce a dull sheen.

### 3.03 INSTALLATION

- A. Comply with sealant manufacturer's written instructions except where more stringent requirements are shown or specified and except where manufacturer's technical representative directs otherwise.
- B. Prime or seal the joint surfaces wherever recommended by the sealant manufacturer. Do not allow prime or sealer to spill or migrate onto adjoining surfaces. Allow primer to dry prior to application of sealants.
- C. Apply masking tape before installation of primer, in continuous strips in alignment with the joint edge to produce sharp, clean interface with adjoining materials. Remove tape immediately after joints have been sealed and tooled as directed.
- D. Do not install sealants without backer rods or bond breaker tape.
- E. Roll the back-up rod stock into the joint to avoid lengthwise stretching. Do not twist, braid, puncture or prime backer-rods.
- F. Employ only proven installation techniques, which will ensure that sealants will be deposited in uniform, continuous ribbons without gaps or air pockets, with complete "wetting" of the joint bond surfaces equally on opposite sides. Except as otherwise indicated, fill sealant rabbet to a slightly concave surface, slightly below adjoining surfaces. Where horizontal joints are between a horizontal surface and a vertical

surface, fill joint to form a slight cove, so that joint will not trap moisture and dirt.

- G. Install sealants to depths as recommended by the sealant manufacturer but within the following general limitations, measured at the center (thin) section of the bead.
  - 1. For horizontal joints in sidewalks, pavements and similar locations sealed with elastomeric sealants and subject to traffic and other abrasion and indentation exposures, fill joints to a depth equal to 75 percent of joint width, but not more than 5/8-inch deep or less than 3/8-inch deep.
  - 2. For vertical joints subjected to normal movement and sealed with elastomeric sealants, but not subject to traffic, fill joints to a depth equal to 50 percent of joint width, but not more than 1/2-inch deep or less than 1/4-inch deep.
- H. Remove excess and spillage of compounds promptly as the Work progresses.
- I. Cure sealants and caulking compounds in compliance with manufacturer's instructions and recommendations, to obtain high early bond strength, internal cohesive strength and surface durability.

3.04 FIELD QUALITY CONTROL

- A. Where questions of compatibility of sealants and substrate arise the sealant manufacturer shall test the substrate in question for compatibility with the specified sealant and report his findings, with recommendations, to Engineer. Any required sealant change shall be at no additional expense to the City.
- B. Do not proceed with installation of elastomeric sealants over joint surfaces which have been painted, lacquered, waterproofed or treated with water repellent or other treatment or coating unless a laboratory test for durability (adhesion), in compliance with Paragraph 4.3.9 of ASTM C 920 has successfully demonstrated that sealant bond is not impaired by the coating or treatment. If laboratory test has not been performed, or shows bond interference, remove coating or treatment from joint surfaces before installing sealant.
- C. After nominal cure of exterior joint sealants which are exposed to the weather, test for water leaks. Flood the joint exposure with water directed from a 3/4-inch garden hose, without nozzle, held perpendicular to wall face, 2 feet-0 inch from joint and connected to a water system with 30 pounds per square inch minimum normal water pressure. Move stream of water along joint at an approximate rate of 20 feet per minute.

## **GENERAL SPECIFICATION 07900 -- CAULKING AND SEALANTS**

---

- D. Test approximately 5 percent of total joint system, in locations which are typical of every joint condition, and which can be inspected easily for leakage on opposite face. Conduct test in the presence of Engineer, who will determine the actual percentage of joints to be tested and the actual period of exposure to water from the hose, based upon the extent of observed leakage, or lack thereof.
- E. Where nature of observed leakage indicates the possibility of inadequate joint bond strength, Engineer may direct that additional testing be performed at a time when joints have been fully cured, followed by natural exposure through both extreme temperatures and returned to the lowest range of temperature in which it is feasible to conduct testing. Perform testing as directed at any time within 24 months of installation date.

### **3.05 ADJUSTMENT AND CLEANING**

- A. Repair sealant installation at leaks or, if leakage is excessive, replace sealant installation as directed.
- B. Clean adjacent surfaces of sealant or soiling resulting from the Work. Use solvent or cleaning agent recommended by the sealant manufacturer. Leave all finish work in a neat clean condition.
- C. Protect the sealants during the construction period so that they will be without deterioration, soiling, or damage at the time of the City' s Final Acceptance.

END OF SECTION

**GENERAL SPECIFICATION 08110 - GALVANIZED STEEL FRAMES  
AND DOORS**

---

**SECTION 08110  
Galvanized Steel Frames and Doors**

**PART 1 GENERAL**

**1.01 SECTION INCLUDE**

- A. The Contractor shall furnish and install all doors, frames, transoms, sidelights, and associated equipment shown on the Contract Drawings and specified herein.
- B. The Contractor shall be responsible for coordinating all work in this Section with work covered under Section 08710 - Finish Hardware.
- C. The following index of this Section is included for convenience:

<u>Article</u>	<u>Title</u>	<u>Page</u>
		08110-
PART 1	GENERAL .....	1
1.01	Section Include.....	1
1.02	Related Section .....	1
1.03	Payment.....	2
1.04	References.....	2
1.05	Design Requirements .....	2
1.06	Submittals .....	2
1.07	Quality Assurance.....	2
1.08	Delivery, Storage And Handling.....	4
PART 2	PRODUCTS.....	4
2.01	Manufacturers .....	4
2.02	Stainless Steel Doors.....	4
2.03	Steel Frames.....	5
2.04	Steel Combination Frames And Trim.....	6
2.05	Anchors For Steel Frames.....	7
2.06	Fabrication And Workmanship.....	7
2.07	Labeled Work.....	8
2.08	Hardware.....	8
PART 3	EXECUTION.....	8
3.01	Installation.....	8
3.02	Protection And Cleaning.....	9

**1.02 RELATED SECTION**

- A. General Specification 08710 - Finish Hardware

**GENERAL SPECIFICATION 08110 - GALVANIZED STEEL FRAMES  
AND DOORS**

---

1.03 PAYMENT

- A. Payment for steel doors and frames shall be as described in the Detailed Specifications.

1.04 REFERENCES

- A. ASTM A924 - General Requirements for Steel Sheet, Metallic-Coated by the Hot-Dip Process

1.05 DESIGN REQUIREMENTS

- A. All work shall comply with the New York City Building Code.
- B. All work shall be fabricated in compliance with the Hollow Metal Manufacturer's Association, the Steel Door Institute and these Sections.

1.06 SUBMITTALS

- A. Contractor shall submit Shop Drawings for approval of the Engineer. Submittals shall include, but not be limited to the following:
  - 1. Samples shall include:
    - a. Corner sections of frames and trim.
    - b. Cut-away corner sections of hollow metal doors showing internal reinforcement specified.
    - c. Insulating material.
- B. Shop Drawings shall include, but not be limited to:
  - 1. Complete layout and installation drawings and schedules with clearly marked dimensions. Drawings shall indicate:
    - a. Details of construction.
    - b. Profiles.
    - c. Gauges.
    - d. Reinforcing.
    - e. Location of all doors and frames.

1.07 QUALITY ASSURANCE

- A. Provide steel doors and frames and accessories manufactured by a single firm specializing in the production of this type of Work and complying with specified standards of ANSI, NFPA, SDI and UL.
- B. Requirements of Regulatory Agencies:
  - 1. The Office of Technical Certification and Research (OTCR) of the New York City Department of Buildings: Where, in order to

## GENERAL SPECIFICATION 08110 - GALVANIZED STEEL FRAMES AND DOORS

---

be incorporated into the work, a particular item or product system specified by Engineer requires acceptance by the New York City Commissioner of Buildings, Contractor shall ensure that the product manufacturer has obtained such approval, without additional expense to the City, and in providing the City with an approved certified copy from the Approved Independent Agency, for the item or product system which shall be submitted to Engineer as part of the Working Drawing approval process. Contractor may submit, in place of products specified by Engineer, products which are “equal” in all ways to the product specified that is NYC code prescribed or alternate the code. Such “or approved equal” product submissions shall not change the requirements of these Specifications as to performance, required features or properties, as determined by Engineer, and shall not require additional compensation to Contractor or additional expense to the City. Final acceptance of “equal” is at the sole determination of Engineer.

2. Comply with all applicable requirements of governing authorities and codes for all Work.
3. In those instances where the Commissioner of Buildings requires a certificate of compliance of the manufacturer or producer certifying that the item or product system was tested and is equivalent to material of the same kind and quality regularly being manufactured by such manufacturer or producer Contractor shall provide all such certificates to the Commissioner of Buildings without additional expense to the City
4. Fire rated Assemblies: Wherever fire-resistance classification is shown or scheduled for steel doors and frames (3-hour, 1-1/2-hour, and similar designations), provide fire-rated assemblies investigated and tested as complete assemblies including type of fire door hardware to be used. Identify each fire door, frame and stick system assembly with recognized testing laboratory labels, indicating applicable fire rating of both door, frame and stick assembly.

### C. Material Requirements:

1. Doors, frames and frame components shall be manufactured from hot-dipped galvanized steel having an A60 zinc coating conforming to ASTM A924.
2. Galvanized steel shall be treated to ensure positive paint adhesion.

## GENERAL SPECIFICATION 08110 - GALVANIZED STEEL FRAMES AND DOORS

---

### 1.08 DELIVERY, STORAGE AND HANDLING

- A. All materials shall be boxed or crated and suitably protected prior to shipment from the factory. Protection shall be arranged to protect all hardware which may be attached.

### PART 2 PRODUCTS

#### 2.01 MANUFACTURERS

- A. The product shall be as manufactured by:
  1. Pioneer Industries Division, Hackensack, NJ.
  2. Ceco Door Products, Omaha, NE.
  3. Or approved equal.

#### 2.02 STEEL DOORS

##### A. Materials

1. Doors shall be of the finest commercial quality No. 16 gauge galvanized steel, 1-3/4-inch thick, of sizes shown.
2. Door louvers in fireproof doors shall be fabricated to maintain the fire rating scheduled for the door.
3. All doors shall be provided with stainless steel tags, 1/2-inch diameter by 1/16-inch thick, stamped with the door number and black Japan-filled; numbers shall conform to those in the Door Schedule.

##### B. Construction

1. Doors shall have a one piece kraft honeycomb core securely bonded under heat and pressure to both face sheets. Honeycomb core shall have a 1 inch hexagonal cell impregnated with phenolic resin. There shall be no seams on the faces or edges of the doors. Vertical edges shall be continuously welded, full height of the door. Exterior doors shall be capped to prevent moisture penetrating the door.
2. Double doors shall have applied galvanized steel astragals, 1/8-inch by 1- 1/2-inch.
3. Heads and jambs of frames shall be matched, mitered, welded and finished to present a smooth surface for finishing. Provide a minimum of 3 anchors per jamb, as well as clip angle for floor anchorage. Prepare frames for all hardware at factory from templates furnished. All hardware cutouts shall be reinforced



## GENERAL SPECIFICATION 08110 - GALVANIZED STEEL FRAMES AND DOORS

---

with 1/8-inch plate welded to frame; 3/16-inch plate shall be used for hinge reinforcements.

4. Jambs shall be constructed to be set on the finished floor. Rubber mutes shall be shipped attached to lock jambs on single doors and on head members for double doors.
5. Glass for all doors shall be secured with mouldings of No. 20 gauge galvanized steel fastened with stainless steel counter-sunk oval head machine screws. The mouldings shall be assembled as frames with corners welded.
6. All exterior doors shall be fully weatherstripped, as indicated in General Specification 08710 - Finish Hardware.
7. Louvers in fireproof doors shall be constructed of No. 18 gauge galvanized steel and shall be equipped with a fusible link and automatic mechanism as approved by the New York City Building Department Bureau of Standards and Appeals and finished to match face of door.
8. Concealed reinforcements of sheet or bar steel shall be provided for hardware and for all attached work. Reinforcement for butt side of doors shall be a continuous 3/16-inch galvanized steel plate. Lock reinforcement shall be No. 12 gauge galvanized steel sheet. Reinforcement for door closures, holders, checks and brackets shall be No. 12 gauge plate of length as required for finish hardware.
9. Reinforce tops and bottoms of door with minimum No. 16 gauge horizontal galvanized steel closing channels, as integral part of door construction, welded continuously to the outer sheets. Close top and bottom edges to provide weatherseal, using 16 gauge flush-mounted inverted closure channels continuously adhered to face sheets with structural silicone adhesive.
10. Edge profiles shall be provided on both stiles of doors beveled 1/8 inch in 2 inches.

### 2.03 STEEL FRAMES

- A. Materials shall be free from defects impairing strength, durability, and/or pressed as required for their respective function. Molded work shall have sharply defined profiles and arises, be clean and sharp. Work shall be of proper dimensions to receive work of others. The indicated and specified thicknesses of the metal are minimum.
- B. Gauges for steel used in the work shall be as follows:

**GENERAL SPECIFICATION 08110 - GALVANIZED STEEL FRAMES  
AND DOORS**

---

<b>Combination Metal Frames and Trim</b>	<b>U.S. Gauge</b>
Exterior Combination Frames & Trim	No. 12
Interior Combination Frames & Trim	No. 16
Interior Combination Frames & Trim For Fire Rated Frames	No. 14
Exterior Scribe Moulding	No. 14
Interior Scribe Moulding	No. 18
Exterior & Interior Angle Floor Knees, Adjustable Anchors, Slides & Adjustable Anchors	No. 16
Fillers	As Required
<u>Hardware Reinforcement</u>	
Butts, Checks, overhead door holders, bracking pulls	3/16" thick
Locking Latches	No. 12
<u>Trim</u>	No. 16

**2.04 STEEL COMBINATION FRAMES AND TRIM**

- A. Steel combination frames and trim shall be placed at door openings, as shown on the Contract Drawings.
- B. Steel combination frames and trim shall be of size and approximate design shown on the Contract Drawings, have integrally molded trim and loose molds according to contours of details, reinforced, drilled tapped for hardware. The type, as detailed, covers the general run of frames for the work but the forming shall be varied from that shown where indicted by special details or necessitated by other conditions.
- C. Miter corners accurately, weld, and dress exposed joints to render same inconspicuous. Spreaders shall be of an approved type.
- D. Frames shall extend to rough concrete slab, bottoms provided with suitable angle clips for securing to jambs. Heads of frames for openings wider than 3 feet shall be reinforced with angles or channels formed of No. 10 gauge galvanized steel spot welded. Where waterproofing occurs, frames shall extend 1 inch below finished floor. Where required to receive labeled ratings, frames shall be fabricated of gauges required and shall be provided with the necessary labels.
  - 1. Provide steel labels permanently attached to section of frame concealed by closed door.

**GENERAL SPECIFICATION 08110 - GALVANIZED STEEL FRAMES  
AND DOORS**

---

- E. Slots shall be provided at upper sections of vertical members for securing temporary wood blocking to which shall be nailed the braces for holding jambs in place while building walls. All doors frames shall be provided with rubber door silencers, not less than 2 per jamb.
  - 1. Rubber door silencers shall be shipped attached to lock jamb on single doors and on head members for double doors.
- F. Provide holes as approved for fastening wood blocking and trim where such are required by the Drawings.

2.05 ANCHORS FOR STEEL FRAMES

- A. Door frames in concrete openings shall be anchored with 4 hex head stainless steel expansion bolts for each jamb and two hex head stainless steel expansion bolts for each head; where steel lintels occur, machine bolts shall be used. Removable stops shall be installed to cover the bolt heads, the stops to be fastened with counter sunk oval head screws.
- B. Door frames in brick or hollow tile openings shall have adjustable anchors spaced 12 inches from the top and bottom of rough bucks and intermediate anchors shall be spaced not more than 30 inches apart on each side. Anchors shall slide on a No. 14 gauge 6 inches long steel strap securely welded to rough bucks. The leg extending into the wall shall be crimped No. 14 gauge steel at least 8 inches long where possible and 3 inches wide, except that the width shall not exceed the thickness of the masonry, nor shall the edge of the anchor come closer than 1/2 inch to the finished face of a wall.
- C. Door frames in gypsum wall board partition walls shall be provided with welded-in steel anchors, which shall be screw-adjusted after the frame is installed, positioning the jambs solidly against wall structure.

2.06 FABRICATION AND WORKMANSHIP

- A. All metal work shall be accurately fabricated and neatly assembled so as to be free from dents, tool marks, warpage, buckle or open joints. All lines shall be straight and true to curvatures as required, arises and angles as sharp as practical, moldings true to profile, mitres formed in true alignment and abutting profiles shall intersect accurately.
- B. Molded members and moldings shall be as shown on the Contract Drawings, unless otherwise approved. Stock moulding shall be as shown on the Contract Drawings unless otherwise approved. Stock moldings which closely approximate the contours shown on the Contract Drawings will be accepted.
- C. All items of template hardware, drilling and tapping shall be located by templates so that accurate alignment will be secured. Templates should be located before manufacturing is commenced.

## GENERAL SPECIFICATION 08110 - GALVANIZED STEEL FRAMES AND DOORS

---

- D. All members shall be accurately fastened together so as to provide rigid construction in the assembled work. Removable members shall be secured with countersunk head tamperproof machine screws not more than twelve (12) inches apart. All connections, except those of removable members shall be welded or interlocked.
- E. All exposed face joints between members shall be continuously welded and dressed smooth and flush to be practically invisible.
- F. Sinkages, cutouts and concealed reinforcement shall be provided as required for the proper installation and attachment of all hardware.
- G. Sinkages shall be provided for butts lock fronts and strikes so that the exposed surfaces of hardware will finish flush with adjacent surfaces.

### 2.07 LABELED WORK

- A. Door openings to receive fire ratings as indicated on the Contract Drawings shall have frames and doors and equipment of gauges meeting the requirements for the rating noted by the BSA. Frames and doors shall bear the necessary label and shall be labeled separately.
- B. Each labeled door and frame shall be cut and reinforced to receive the type hardware required.

### 2.08 HARDWARE

- A. Furnish and apply, in connection with this work, all hardware not requiring special finish such as screws, anchors, braces, bolts, etc., as required to erect this work properly.
- B. Finishing hardware is described elsewhere in these Sections. The Contractor shall, however, receive, check, store and apply the finishing hardware insofar as it occurs in connection with work under this Section. Protect door knobs by covering with cloth pads securely wired in place and do not apply escutcheons and other trim until directed to do so, by the Engineer.
- C. Specified manufacturer's supplemental and special reinforcement for hinges, surface applied closers, holders, coordinators, stops and strikes shall be manufacturer's standard but not less than specified and recommended for maximum heavy-duty construction.

## PART 3 EXECUTION

### 3.01 INSTALLATION

- A. All doors and frames specified herein shall be neatly installed in designated locations indicated on Drawings.

**GENERAL SPECIFICATION 08110 - GALVANIZED STEEL FRAMES  
AND DOORS**

---

- B. Fixed units shall be securely fastened in place and operative units adjusted to work properly.
- C. Combination frames and trim shall be securely anchored in place with jambs filled solidly with mortar.
- D. Perform all necessary cutting, drilling and fitting for securing work in position including all necessary cutting, drilling and tapping of the work to accommodate the work of other trades. Drilling and tapping for non-template hardware shall be performed at the site.

3.02 PROTECTION AND CLEANING

- A. The Contractor shall provide protection against stains, dirt or damage to the finished installation. The doors shall be adjusted at installation for proper operation. At conclusion of construction, doors shall have any final adjustments made in order to place the doors in perfect operating condition.
- B. Upon completion of the project all finished work of this Section shall be carefully cleaned. Defective finish shall be removed and refinished, and all work left clean and perfect.

END OF SECTION

**GENERAL SPECIFICATION 08110 - GALVANIZED STEEL FRAMES  
AND DOORS**

---

NO TEXT ON THIS PAGE

**GENERAL SPECIFICATION 08311 - ACCESS DOORS**

---

**SECTION 08311  
Access Doors**

**PART 1 GENERAL**

**1.01 SECTION INCLUDES**

- A. Access doors as specified herein shall include aluminum sidewalk doors, aluminum floor doors and steel wall access doors to be mounted in masonry or gypsum board walls, ceiling access doors, and appurtenances.
- B. Access doors shall be provided where shown on the Contract Drawings, specified in the Detailed Specifications, or as required for a complete installation.
- C. The following index of this Section is presented for convenience.

<u>Article</u>	<u>Title</u>	<u>Page</u>
		08311-
PART 1	GENERAL .....	1
1.01	Section Includes .....	1
1.02	Related Section .....	1
1.03	Payment.....	1
1.04	References.....	2
1.05	Performance Requirements.....	2
1.06	Submittals .....	2
1.07	Delivery, Storage And Handling.....	3
PART 2	PRODUCTS.....	3
2.01	Manufacturers .....	3
2.02	Materials .....	3
PART 3	EXECUTION.....	4
3.01	Examination .....	4
3.02	Installation.....	4
3.03	Protection .....	4
3.04	Adjustment.....	4
3.05	Cleaning .....	5

**1.02 RELATED SECTION**

- A. General Specification 09900 - Painting

**1.03 PAYMENT**

- A. No direct payment will be made for access doors, accessories, or appurtenances; the cost shall be included in the lump sum price bid for the Contract, except as provided for in the Detailed Specifications

## GENERAL SPECIFICATION 08311 - ACCESS DOORS

---

### 1.04 REFERENCES

- A. AADAF - Aluminum Association Designation System for Aluminum Finishes
- B. AASHTO - American Association of State Highway and Transportation Officials
- C. ASTM B221 - Aluminum and Aluminum-Alloy Extruded Bars, Rods, Wire, Profiles and Tubes, Standard Specification for
- D. ASTM B209 - Aluminum and Aluminum-Alloy Sheet and Plate, Standard Specification for
- E. NAAMM - National Association of Architectural Metal Manufacturers

### 1.05 PERFORMANCE REQUIREMENTS

- A. Sidewalk doors shall be detailed and fabricated based on calculations prepared by the manufacturer indicating that sidewalk doors are capable of withstanding a permanently applied minimum live load of 300 pounds per square foot without permanent deformation or deflection in excess of 1/150 of the span.
- B. Floor doors shall be detailed and fabricated based on calculations prepared by the manufacturer indicating that floor doors are capable of withstanding a permanently applied minimum live load of 150 pounds per square foot without permanent deformation or deflection in excess of 1/150 of the span.
- C. Where shown or specified, sidewalk or floor doors shall be detailed and fabricated based on calculations prepared by the manufacturer indicating that doors are capable of withstanding a permanently applied minimum highway live load standard of H20 based on dimensions, performance criteria, and loadings according to AASHTO Standard Specification for Highway Bridges.

### 1.06 SUBMITTALS

- A. The Contractor shall submit Shop Drawings for approval of the Engineer. Submittals shall include, but not be limited to: catalog cuts, drawings, and reference materials.
  - 1. Shop Drawings: Submit for approval the following:
    - a. Copies of specifications, installation instructions and general recommendations from the sidewalk door, floor door, and access door manufacturers, for each type of product. Include manufacturer's data substantiating that the materials comply with the requirements of the Contract Documents.
    - b. Drawings showing extent of the Work and all details required for the Work referencing system components and installation requirements.
    - c. Calculations indicating compliance with performance criteria specified, and used by the manufacturer for preparing details of



## GENERAL SPECIFICATION 08311 - ACCESS DOORS

---

fabrication, prepared, signed and stamped with the seal of a Professional Engineer licensed to practice in the State of New York and recognized as an expert in the required work.

### 1.07 DELIVERY, STORAGE AND HANDLING

#### A. Delivery of Materials:

1. Materials shall not be delivered to the project site before the time of installation.
2. Materials shall be delivered in sufficient quantities to allow continuity of the Work.

#### B. Storage of Materials:

1. Materials shall be stored in original, undamaged packaging with manufacturer's labels and seals intact.
2. Materials shall be protected from damage during storage primarily by minimizing the amount of time they are stored at the job-site before being incorporated into construction systems.

#### C. Handling of Materials:

1. Materials shall be handled in such a manner to avoid damage or breakage.
2. Materials shall not be exposed to detrimental conditions or physical damage. Materials which are so exposed shall be removed for the site and shall not be incorporated into the Work.

## PART 2 PRODUCTS

### 2.01 MANUFACTURERS

- A. Manufacturers shall be as specified in the Detailed Specifications.

### 2.02 MATERIALS

- A. Sidewalk doors shall be fabricated of aluminum and shall include gutter and drain, and Type 316 stainless steel hardware. Doors shall open 90 degrees, lock automatically, and shall be equipped with slam lock. Double leaf doors shall be equipped with safety chains.
- B. Floor doors shall be fabricated of aluminum and shall include Type 316 stainless steel hardware. Doors shall open 90 degrees, lock automatically, and shall be equipped with slam lock. Double leaf doors shall be equipped with safety chains.
- C. Wall access doors shall comprise frames of a minimum of 16-gauge steel and doors of a minimum of 14-gauge steel. Access door assembly shall include concealed spring type hinges capable of opening to 170 degrees. Doors shall be furnished with flush locks, screwdriver operated, with metal cam. For fire-rated openings, doors shall bear a UL rating as required for the fire rating of the wall, but not less than 1-1/2 hour "B" label (250 degree F) rated, with frames of 16-gauge steel and insulated door with panels of 20-gauge steel, sandwich type, and continuous hinges.

## GENERAL SPECIFICATION 08311 - ACCESS DOORS

---

- D. Ceiling access doors shall be a downward opening type. Ceiling access doors shall comprise doors and frames of a minimum of 14-gauge galvanized steel. Door shall be insulated with 1 inch glass fiber and shall be equipped with a spring lever to assist in operation. Latch shall have a removable key handle. Door and frame shall be designed to receive acoustical tile so as to provide a flush ceiling surface where required. A plastic stop and lath support shall be provided for plaster ceilings. Door size shall be as indicated on the Contract Drawings or a minimum opening of 30 inches by 30 inches.
- E. Finishes: Sidewalk doors, floor doors, and access doors shall be finished as follows:
  - 1. Interior sidewalk and floor doors shall be furnished with an Architectural Class I, AA-C22A41 clear coating.
  - 2. Exterior sidewalk and floor doors shall be furnished with an Architectural Class I, AA-C22A41 clear coating.
  - 3. Wall and ceiling access doors and frames shall be provided with a factory applied baked-on enamel prime coat chemically bonded to the steel. Doors and frames shall be field painted to match walls in accordance with General Specification 09900 - Painting and the Detailed Specifications.

### PART 3 EXECUTION

#### 3.01 EXAMINATION

- A. The Contractor shall verify that areas to receive access doors are properly prepared and completed to final elevations.

#### 3.02 INSTALLATION

- A. Sidewalk doors, floor doors, and wall and ceiling access doors shall be installed in accordance with the manufacturer's recommendations and approved Shop Drawings.

#### 3.03 PROTECTION

- A. All components of the Work shall be protected until Final Acceptance by the City.
- B. Work which cannot be completed before onset of weather detrimental to the Work shall be completely covered and protected in such a manner as to deflect water and weather from the installation without damaging adjacent Work.
- C. Protect sidewalk doors, floor doors, and access doors from all damage and abuse until Final Acceptance by the City.

#### 3.04 ADJUSTMENT

- A. Sidewalk doors, floor doors, and wall and ceiling access doors, and their respective hardware components shall be adjusted for proper alignment and smooth operation.
- B. System components which are dislodged, damaged, expanded, broken, penetrated or crushed by subsequent installation operations or damaged by detrimental weather shall be immediately replaced with undamaged material in compliance with the Sections and properly protected as specified.

## **GENERAL SPECIFICATION 08311 - ACCESS DOORS**

---

### 3.05 CLEANING

- A. After installation, sidewalk doors, floor doors, and access doors shall be cleaned and left in a neat condition. Units shall be cleaned using materials and processes as recommended by the manufacturer.

END OF SECTION

**GENERAL SPECIFICATION 08311 - ACCESS DOORS**

---

NO TEXT ON THIS PAGE

**SECTION 08710  
Finish Hardware**

**PART 1 GENERAL**

**1.01 SUMMARY**

- A. The Contractor shall provide all labor, materials, equipment and incidentals necessary to perform the work of this Section as shown, specified or required otherwise for a complete job.
- B. Finish hardware is defined to include all items known commercially as finish hardware, as required for swing doors, except special types of unique and non-matching hardware specified in the same Section as the door and door frame.
- C. Types of finish hardware work required include, but are not necessarily limited to, the following:
  - 1. Heavy-duty pivot hinges
  - 2. Electric Power Transfer
  - 3. Electrified Mortise Lock Sets
  - 4. Mortise Locksets
  - 5. Electrified Vertical Rod Panic Exit Devices
  - 6. Panic exit devices
  - 7. Heavy-duty floor-mounted concealed door closers
  - 8. Overhead surface-mounted door closers
  - 9. Extra-heavy-duty overhead holders and stops
  - 10. Magnetic Monitor Switch
  - 11. Acoustic Stripping and Seals
  - 12. Thresholds
  - 13. Silencers
  - 14. Floor stops
  - 15. Miscellaneous items
- D. Written field report on condition of each item of finish hardware actually present on each door at the project site with each item referenced to the approved Shop Drawings. Final approval or final payment shall not be provided to Contractor until field report has been submitted to and approved by the Engineer.
- E. Coordination:

**GENERAL SPECIFICATION 08710 - FINISH HARDWARE**

---

1. Review installation procedures under other Sections and coordinate the installation of items that must be installed with the finish hardware.
  2. Coordinate the work of other Sections in order to provide clearances and accurate positioning of recessed or cast-in-place items required by this Section.
- F. The Contractor shall implement practices and procedures to meet the project’s sustainability goals as identified in the Contract Documents. The Contractor shall ensure that the sustainability requirements of this Section are implemented to the fullest extent.
- G. The following index of this Section is presented for convenience.

<u>Article</u>	<u>Title</u>	<u>Page</u>
		08710-
PART 1	GENERAL.....	1
1.01	Summary.....	1
1.02	Payment.....	2
1.03	References.....	3
1.04	System Design Requirements.....	3
1.05	Quality Assurance.....	4
1.06	Submittals.....	5
1.07	Delivery, Storage And Handling.....	7
1.08	Project Conditions.....	7
PART 2	PRODUCTS.....	7
2.01	Manufacturers.....	7
2.02	Materials.....	10
PART 3	EXECUTION.....	21
3.01	Examination.....	21
3.02	Preparation.....	21
3.03	Installation.....	22
3.04	Field Quality Control.....	22
3.05	Adjustment And Cleaning.....	23
3.06	Schedules.....	24

1.02 PAYMENT

- A. No separate payment will be made for performing any work of this Section and all costs associated thereof shall be included in the lump sum price bid for the Contract, except as provided for in the Detailed Specifications.

1.03 REFERENCES

- A. Doors and Hardware Institute
  - 1. Recommended Locations for Architectural Hardware for Standard Steel Doors & Frames;
  - 2. Recommended Locations for Builders' for Custom Steel Doors & Frames
- B. South Coast Air Quality Management District (SCAQMD)
  - 1. Rule 1113 -- Architectural Coatings
  - 2. Rule 1168 -- Adhesives and Sealants
- C. Green Seal (GS)
  - 1. GS-11 -- Green Seal Environmental Standard for Paints and Coatings.
  - 2. GC-03 -- Green Seal Environmental Criteria for Anti-Corrosive Paints.
- D. ASTM C920 -- Standard Specification for Elastomeric Joint Sealants

1.04 SYSTEM DESIGN REQUIREMENTS

- A. Where the finish, shape, size or function of a member receiving finish hardware is such as to prevent the use of or make unsuitable the types specified, furnish similar types having as nearly as practicable the same operation.
- B. If finish hardware for any location is not specified, provide finish hardware equal in design and quality to adjacent finish hardware for comparable openings.
- C. Furnish finish hardware items of proper design for use on doors and frames of the thickness, profile, swing, security and similar requirements, as necessary for proper installation and function.
- D. Unless otherwise specified, comply with the technical guidance of Door and Hardware Institute (DHI), for locating hardware on standard or customized steel doors and frames, as applicable.
- E. Provide stainless steel finish hardware or matching finish hardware as specified for all doors and frames.
- F. Sustainable Design Requirements
  - 1. VOC Content: Products applied on site and within the building's weatherproofing system shall comply with VOC limits of authorities having jurisdiction and the following VOC

## GENERAL SPECIFICATION 08710 - FINISH HARDWARE

---

limits of when calculated according to SCAQMD Rule 1113 and Rule 1168, Green Seal Standard GS-11, Green Seal Criteria GC-03:

- a. Architectural Sealants: 250 g/L
  - b. Sealant Primers for Nonporous Substrates: 250 g/L
  - c. Sealant Primers for Porous Substrates: 775 g/L
  - d. Multipurpose Construction Adhesives: 70 g/L
  - e. Flat Paints and Coatings: VOC not more than 50 g/L
  - f. Nonflat Paints and Coatings: VOC not more than 150 g/L
  - g. Primers, Sealers, and Undercoaters: VOC not more than 200 g/L
  - h. Anticorrosive and Antirust Paints Applied to Ferrous Metals: VOC not more than 250 g/L.
- G. Project-specific system description or design requirements for the work of this Section will be provided in the Detailed Specifications (if necessary) to supplement the requirements given herein or in the Contract Drawings.

### 1.05 QUALITY ASSURANCE

- A. Supplier Qualifications: The finish hardware supplier shall have in his employ a member of the DHI as a certified Architectural Hardware Consultant who shall be responsible for checking, supervising and preparing written Field Report for complete finish hardware installation and with on-site presence during the time of installation and adjustment of the Work.
- B. Requirements of Regulatory Agencies: Comply with the applicable requirements of governing authorities and codes for the types of finish hardware specified.
- C. Source Quality Control: Obtain all similar products and accessories from the same manufacturer.
- D. Substitutions
  1. Clearly identify, in a manner which is highlighted to the Engineer, all proposed substitutions, modifications, variations, unspecified features and "or approved equal" products. Provide complete comparative data, comparing "or approved equal" with specified products, at time of Shop Drawings submission.



2. Do not make substitutions after the Engineer's approval of final finish hardware schedule and sample at time of Shop Drawing submission.

1.06 SUBMITTALS

A. Contractor shall submit Shop Drawings for approval of the Engineer. Submittals shall include, but not be limited to the following:

1. Actual unit of each finish hardware item specified incorporating all standard and special features and finishes specified, demonstrated and identified by supplier's representative to the Engineer. Samples shall be presented at time of Shop Drawing submittal as the Engineer will not review or approve Shop Drawings without concurrent sample submissions.
2. The Engineer's review will be for general quality and features of units, compliance with all other requirements is the exclusive responsibility of the Contractor.
3. Approved samples may be incorporated into the finish hardware work.

B. Shop Drawings:

1. Copies of manufacturer's data for each item of finish hardware. Include whatever information may be necessary to show compliance with requirements, and include instructions for installations and for maintenance of operating parts and exposed finishes. Wherever needed, furnish templates to fabricators of other work which is to receive finish hardware.
2. Copies of the finish hardware schedule. Include a separate key schedule, showing clearly how City's final instructions on keying of locks have been fulfilled. Finish hardware schedules are intended for coordination of the Work. Review and acceptance by the Engineer does not relieve the Contractor of his exclusive responsibility to fulfill the requirements as shown and specified.
3. Based on the finish hardware requirements specified, organize the final finish hardware schedule into "hardware sets," indicating complete designation of every item required for each door or opening. Furnish initial draft of schedule at the earliest possible date, in order to facilitate the fabrication of other work (such as stainless steel frames) which may be critical in the Project construction schedule. Furnish final draft of schedule after samples, manufacturer's data sheets, coordination with

Shop Drawings for other work, delivery schedules and similar information have been complete and accepted.

4. Copies of manufacturers' specifications and installation instructions for required materials and components which are not included in other submittal specified in other Sections of this Specifications. Coordinate the requirements of this Section with other submittal and coordinate the submittal of other data in other Sections with the Sections' submittal.
  5. Maintenance Manual: Upon completion of the Work, furnish copies of detailed maintenance manuals, including the following information:
    - a. Product name and manufacturer.
    - b. Name, address and telephone number of manufacturer and local distributor.
    - c. Detailed procedure for routine maintenance and cleaning.
    - d. Detailed procedures for repairs such as dents, scratches and staining.
    - e. Parts identification manual and maintenance manuals for each piece of finish hardware.
- C. Cylinders and Keying System:
1. Provide a great grandmaster keying system.
  2. Equip all locks with manufacturer's special 6-pin tumbler cylinder, with construction master key feature, which permits voiding of construction keys without cylinder removal.
  3. Comply with Engineer's instructions for master keying and, except as otherwise specified, provide individual change key for each lock which is not designated to be keyed alike with a group of related locks.
  4. Key Material: Provide keys of nickel silver only.
  5. Key Quantity: Furnish 3 keys for each lock and 5 keys for each master and grandmaster system. Provide one extra key blank for each lock.
- D. Test Reports: Submit for approval certified laboratory test reports for required performance tests.
- E. Sustainable Design Submittals:
1. VOC Reporting Form. Provide the following information:

## **GENERAL SPECIFICATION 08710 - FINISH HARDWARE**

---

- a. For all paints, coatings, sealants and adhesives used on site and within the building's weatherproofing system provide the VOC content in grams/Liter (g/L) less water and other exempt compounds, if applicable.

### 1.07 DELIVERY, STORAGE AND HANDLING

#### A. Delivery of Materials:

- 1. Deliver finish hardware sufficiently in advance of its setting for proper inspection.
- 2. Pack each piece of finish hardware separately, complete with screws, keying, instructions and templates, tagged to correspond with the approved finish hardware schedule.
- 3. Deliver individually packaged finish hardware items at the proper time to the proper locations for installation.

#### B. Storage of Materials:

- 1. Provide secure lock-up for finish hardware stored at the project site, but not yet installed.
- 2. Store finish hardware in manufacturers' original packages.

#### C. Handling of Materials: Control the handling and installation of finish hardware items which are not immediately replaceable, so that the completion of the Work will not be delayed by finish hardware losses, both before and after installation.

### 1.08 PROJECT CONDITIONS

- A. Coordinate with other work by furnishing Shop Drawings, inserts, templates and similar items at the appropriate times for proper sequencing of construction without delays.

## PART 2 PRODUCTS

### 2.01 MANUFACTURERS

#### A. Heavy Duty Pivot Hinges:

- 1. H147 Bottom Pivot, H180 Top Pivot and M190 Heavy-Duty Intermediate Pivots as manufactured by:
  - a. Rixson, a subsidiary of Yale Security, Incorporated, Monroe, NC.
  - b. Or approved equal.

#### B. Electric Power Transfer:

## GENERAL SPECIFICATION 08710 - FINISH HARDWARE

---

1. EPT-10 Electric Power Transfer as manufactured by Von Duprin or EPT-2 for magnetic monitor switches, Indianapolis, IN.
  2. Or approved equal.
- C. Electric Mortise Lock Sets
1. Heavy-Duty Mortise Lockset L9080 PEL RX with RX (request to exit) function, Lever Handle 03N (plug only to show) with MS750 24 VAC, 3 amp transformer as manufactured by Schlage, Carmel, IN. Provide EL (electric locking) series at all doors except at exterior doors and as noted otherwise.
  2. Or approved equal.
- D. Mortise Lock Sets
1. Heavy-Duty Mortise Lock Set, Newport N9M (ANSI No. 14), by Corbin Russwin, an ASSA ABLOY Group Company.
  2. Or an approved equal.
- E. Electrical Vertical Rod Panic Exit Device
1. Electric panic device EL 9848L SS RX (signal switch and request to exit) Lever Set 03 by Von Duprin, Indianapolis, IN, with (latches top and bottom) with MS750 24 VAC, 3 amp transformer.
  2. Or approved equal.
- F. Panic Exit Devices
1. ED5200A 3-Hour Fire Listed Surface Rim Exit Device, Finish BHMA 630 (ANSI A156.3, Type 1, Grade 1) by Corbin Russwin, an ASSA ABLOY Group Company.
  2. Or an approved equal.
- G. Vertical Rod Panic Exit Devices
1. ED5400A 3-Hour Fire Listed Surface Vertical Rod Exit Device, Finish BHMA 630 (ANSI A156.3, Type 2, Grade 1) by Corbin Russwin, an ASSA ABLOY Group Company.
  2. Or approved equal.
- H. Heavy Duty Floor Mounted Door Closer
1. SC H27CWF by Rixson, a Subsidiary of Yale Security, Inc., an ASSA ABLOY Group Company, Monroe, NC.
  2. Or approved equal.

## **GENERAL SPECIFICATION 08710 - FINISH HARDWARE**

---

- I. Overhead Surface-Mounted Door Closer
  - 1. DC8000 Parallel Arm Mounting Heavy-Duty Non-Hold Open Arm with Stop (DC8210 Series), by Corbin Russwin, an ASSA ABLOY Group Company.
  - 2. Or approved equal.
- J. Extra Heavy-Duty Overhead Holders and Stops
  - 1. 904H – US32D Extra Heavy-Duty Surface-Mounted Overhead Door Holder/Stop as manufactured by Glynn-Johnson Part of Worldwide Ingersoll-Rand, Dublin, Ireland
  - 2. Or approved equal.
- K. Flash Bolts and Automatic Flush Bolts (forged/wrought brass parts)
  - 1. FB458 Manual Flush Bolts, US26D finish, as manufactured by Ives, Part of Worldwide Ingersoll-Rand, Dublin, Ireland.
  - 2. Or approved equal.
- L. Flush Bolts and Automatic Flush Bolts (cast bronze parts)
  - 1. FB31P Automatic Flush Bolts, US32D finish, by Ives, Part of Worldwide Ingersoll-Rand, Dublin, Ireland.
  - 2. Or approved equal.
- M. Coordinators
  - 1. COR52-US26D by Ives, Part of Worldwide Ingersoll-Rand, Dublin, Ireland.
  - 2. Or approved equal.
- N. Astragals
  - 1. 357C by Pemko Manufacturing Company, Memphis, TN.
  - 2. Or approved equal.
- O. Dust-Proof Strikes
  - 1. DP1 and DP2 as manufactured by Ives, Part of Worldwide Ingersoll-Rand, Dublin, Ireland.
  - 2. Or approved equal.
- P. Magnetic Monitor Switch
  - 1. RX (exit device) or LX (latchbolt) magnetic monitor switch with PT 750 24 VAC transformer by Von Duprin, Indianapolis, IN.
  - 2. Or approved equal.

## GENERAL SPECIFICATION 08710 - FINISH HARDWARE

---

Q. Weatherstripping (bumper type)

1. No. 170AA by Zero International, Inc., Bronx, NY.
2. Or approved equal.

R. Acoustic Seals

1. 3708AA (Head and Jambs), 368AA (Semi-Mortised Automatic Door Bottom), and 564A (Threshold) by Zero International, Inc, Bronx, NY.
2. Or approved equal.

S. Thresholds

1. 655A (interior saddles) by Zero International, Inc., 800 (doors with floor closers), Type 3 Offset by Rixson, a Subsidiary of Yale Security, Inc., an ASSA ABLOY Group Company, Monroe, NC.
2. Or approved equal.

T. Offset Thresholds

1. 566A (interior doors) by Zero International, Inc., No. 700 (with floor closers) thresholds by Rixson, A Subsidiary of Yale Security, Inc., an ASSA ABLOY Group Company, Monroe, NC. Provide Offset Threshold of similar design as required.
2. Or approved equal.

U. Silencers

1. SR 64 by Ives, Part of Worldwide Ingersoll-Rand, Dublin, Ireland.
2. Or approved equal.

V. Stops

1. FS13, US26D finish, by Ives, Part of Worldwide Ingersoll-Rand.
2. Or approved equal.

### 2.02 MATERIALS

A. Requirements for All Products

1. Hand of Door: Contract Drawings show the swing or hand of each door leaf (left, right, reverse bevel, etc.). Furnish each item of finish hardware for proper installation and operation of the door swing as shown.

## GENERAL SPECIFICATION 08710 - FINISH HARDWARE

---

2. Manufacturer's Nameplate: Do not use manufacturer's products which have manufacturer's name or trade name displayed in a visible location (omit removable nameplates).
  3. Base Metals: Produce finish hardware units of the basic metal and forming method specified, using the manufacturer's standard metal alloy, composition, temper and hardness. Do not substitute materials or forming methods for those specified.
  4. Fasteners: Manufacture finish hardware to conform to published templates, generally prepared for machine screw installation. Do not provide finish hardware which has been prepared for self-tapping sheet metal screws, except as specifically indicated.
  5. Furnish screws for installation, with each finish hardware item. Provide Phillips flat-head screws except as otherwise specified. Finish exposed (exposed under any condition) screws to match the hardware finish or, if exposed in surfaces on other work, to match the finish of such other work as closely as possible, including "prepared for paint" in surfaces to receive painted finish.
  6. Provide fasteners which are compatible with both the unit fastened and the substrate, and which will not cause corrosion or deterioration of finish hardware, base material or fastener.
  7. Provide concealed fasteners for finish hardware units which are not exposed when the door is closed, except to the extent no standard manufacturer units of the type specified are available with concealed fasteners. Do not use through bolts for installation when the bolt head or the nut on the opposite face is exposed in other work under any condition, except where it is not possible to adequately reinforce the Work and use machine screws or concealed fasteners of another standard type of satisfactorily avoid the use of through bolts.
  8. Tools for Maintenance: Furnish a complete set of specialized tools as needed for City's continued adjustment, maintenance, removal and replacement of finish hardware.
- B. Heavy-Duty Pivot Hinges
1. Templates and Screws: Provide only template-produced units.
  2. Base Metal: Fabricate hinges from forged bronze with US 26D Satin Chrome finish.
  3. Number of Hinges: Provide three hinges on each door leaf of less than 60-inches height; provide one additional hinge for next

30-inches of door height; provide two additional hinges for each 30-inches or fraction thereof for doors above 90-inches tall.

4. Hinge Size: Except as otherwise specified or as required to comply with UL and NFPA, provide hinges of the following sizes:
  - a. Exterior and Interior Doors, maximum 48-inches wide: Top and bottom pivots; intermediate pivots based on number of hinges as specified; minimum of one intermediate pivot required on all doors.
5. Types of Hinges: Provide all doors with offset hung, bottom, top and intermediate units with hardened steel pivot pins treated to prevent rusting or binding, permanently seated in an oil impregnated sintered bronze bearing lubricated for the life of the door and capable of supporting a minimum door weight of 800 pounds and recommended by the manufacturer for use on heavy-duty high traffic doors subject to extreme abuse. Provide single acting, mortised mounted units sized for a maximum door width of 4 foot-0 inches. Top pivot shall have a sloped top surface.

C. Electric Power Transfer

1. Provide this accessory at all locations where electrified hardware is provided through door leafs.

D. Electrified Mortise Locks Sets

1. Strikes: Provide manufacturer's standard wrought box strike, for each location and use shown. Provide stainless steel curved lip strikes, unless otherwise recommended by manufacturer, finish to match lock or latch set trim. Device to be UL certified to respond by solenoid operation to lock or unlock and contain a request to exit function microswitch interconnected with interior knob.
2. Lock Throw: Provide minimum of 1-inch anti-friction latch bolt and 1-inch dead bolt throw wherever available on manufacturer's functions specified.
3. Materials: Provide the following materials:
  - a. Latch Bolt: Stainless steel.
  - b. Dead Bolt: Stainless steel.
  - c. Case: Stainless steel.
  - d. Hub: Nickel steel.
  - e. Scalp: Stainless steel.



## GENERAL SPECIFICATION 08710 - FINISH HARDWARE

---

- f. Escutcheon: 8-1/2-inches by 1-3/4-inches stainless steel; US 32D; Satin Stainless Steel.
  4. Backset: Provide minimum backset of 2-3/4-inches.
  5. Finish: US32D Satin Stainless Steel.
- E. Mortise Locks Sets
  1. Strikes: Provide manufacturer's standard wrought box strike, for each location and use shown. Provide stainless steel curved lip strikes, unless otherwise recommended by manufacturer, finish to match lock or latch set trim.
  2. Lock Throw: Provide minimum of 1-inch anti-friction latch bolt and 1-inch dead bolt throw wherever available on manufacturer's functions specified.
  3. Materials: Provide the following materials:
    - a. Latch Bolt: Stainless steel.
    - b. Dead Bolt: Stainless steel.
    - c. Case: Stainless steel.
    - d. Hub: Nickel steel.
    - e. Scalp: Stainless steel.
    - f. Escutcheon: 8-1/2-inches by 1-3/4-inches stainless steel; US 32D; Satin Stainless Steel.
  4. Backset: Provide minimum backset of 2-3/4-inches.
  5. Finish: Us32d Satin Stainless Steel.
- F. Electrified Vertical Rod Panic Exit Devices
  1. Strikes: Provide manufacturer's standard wrought stainless steel jamb-mounted top latch bolt and bottom latch bolt for each location and use shown. Device to be UL certified to respond by solenoid operation to lock or unlock and contain a request to exit function micro-switch interconnected with exit accessory.
  2. Exit Doors: Where required by governing regulations or where shown or scheduled, provide panic exit devices of the type required. Provide units for 1-3/4-inch thick doors.
  3. Lock Throws: Provide minimum of 3/4-inch latch bolt throws.
  4. Provide surface-applied two-point latching exit devices as specified.
  5. Provide the following materials:

- a. Latch Bolt: Stainless steel.
  - b. Case: Stainless steel.
  - c. Cylinders: Brass.
  - d. Front: Stainless steel.
  - e. Chassis: Brass.
  - f. Crossbar: Oval, seamless, knurled crossbar with interlocking expansion collets and roll pins; satin stainless steel; 0.062-inches minimum thickness with steel reinforcing tube.
6. Backset: Provide minimum backset of 2-3/4-inches.
  7. Finish: US 32D Stainless Steel.
  8. Function: ANSI No. 4: entrance by trim when latch bolt is retracted by key or set in a retracted position by key; no thumbpiece.
- G. Vertical Rod Panic Exit Devices
1. Strikes: Provide manufacturer's standard wrought stainless steel jamb-mounted top latch bolt and bottom latch bolt for each location and use shown.
  2. Exit Doors: Where required by governing regulations or where shown or scheduled, provide panic exit devices of the type required. Provide units for 1-3/4-inch thick doors.
  3. Lock Throws: Provide minimum of 3/4-inch latch bolt throws.
  4. Provide surface-applied two-point latching exit devices as specified.
  5. Provide the following materials:
    - a. Latch Bolt: Stainless steel.
    - b. Case: Stainless steel.
    - c. Cylinders: Brass.
    - d. Front: Stainless steel.
    - e. Chassis: Brass.
    - f. Crossbar: Oval, seamless, knurled crossbar with interlocking expansion collets and roll pins; satin stainless steel; 0.062-inches minimum thickness with steel reinforcing tube.
    - g. Backset: Provide minimum backset of 2-3/4-inches.

- h. Finish: US 32D Stainless Steel.
- i. Function: ANSI No. 4: entrance by trim when latch bolt is retracted by key or set in a retracted position by key; no thumbpiece.

H. Floor Mounted Heavy-Duty Door Closers

1. Provide heavy-duty single-acting floor mounted door closers for all doors, and as recommended by the manufacturer for controlling doors weighing up to 800 pounds in high traffic and high abuse situations. Provide recessed floor mounted door closers for all doors.
2. Size of Units: 6-1/2-inches wide by 13-1/4-inches long by 4-inches deep.
3. Provide dress plates and other finished hardware components of satin chrome finish.
4. Provide low temperature hydraulic fluid for all units. Seal units using an adhesive backed rubber gasket.
5. Provide extended spindle as required to accommodate detailing shown.
6. Provide 3/4-inch offset heavy-duty arm coordinated with pivot hinge manufacturer's recommendations for heavy-duty pivot hinges.
7. Provide special cement case anchoring angles mounted on both sides of cast-iron cement case. Provide manufacturer's floor installation template and former kit.
8. Provide heavy-duty units fire-rated and complying with all required governing standards.
9. Provide the following materials and features in addition to others specified herein:
  - a. Provide both floor plate and threshold installation as required.
  - b. Provide floor plate with US26D finish.
  - c. Bottom arm with anti-friction bearing.
  - d. Closing speed adjustment valve and separate latch speed adjustment valve.

I. Overhead Surface-Mounted Door Closers

## GENERAL SPECIFICATION 08710 - FINISH HARDWARE

---

1. Provide all doors, unless specially scheduled or specified as being provided with floor mounted or concealed overhead closers, with surface-mounted overhead door closers. Provide both active and inactive door leafs with closers.
2. Size of Units: Except as otherwise specified, comply with the manufacturer's recommendations for size of door control unit, depending upon size of door, exposure to weather, and anticipated frequency of use.
3. Where parallel arms are specified, and for closers on exterior doors, provide closer unit one size larger than recommended for use with standard arms.
4. Use parallel arm arrangement for doors that would otherwise have the door closer appearing in finished corridors or entries.
5. Comply with UL, Building Materials Directory, and List of Inspected Fire Protection Equipment and Materials, and NFPA No. 80 for doors requiring door closers. Modify closers specified as required.
6. Provide hold open feature for all non-fire rated doors unless otherwise specified.
7. Provide corner bracket mounting on exterior doors. Select all arms to clear weatherstripping, and overhead door holders.
8. Provide long arm to allow door to swing 180 degrees where long arm will eliminate floor mounted stops.
9. Provide closers with spring power adjustment feature capable of increasing spring power 15 percent minimum in all closer sizes.
10. Provide individual regulating valves for closing and latching speeds, and separate adjustable backcheck valve.
11. Provide delayed closing action feature on all door closers. Position valve at top of closure.
12. Provide the following materials and features in addition to others specified herein:
  - a. Full Metal Cover: Aluminum.
  - b. Case: Cast iron.
  - c. Arms: Plated to match full metal covers.
  - d. Other Parts: Steel.
  - e. Extreme temperature fluid.

- f. Security torx machine screws.
  - g. Ten year warranty.
  - h. Provide manufacturer's optional corrosion protection.
13. Finishes: S26D Satin Chrome. Color coordinate all arms and other accessories.
14. Highly Corrosive Atmospheres: Provide all closers with specified manufacturers.
- J. Extra Heavy-Duty Overhead Holders and Stops
- 1. Provide surface-mounted extra heavy-duty overhead holders and stops on all leafs of all doors with hold open feature.
  - 2. Material: Provide the following materials:
    - a. Arm: Stainless steel; 1/4-inch thick.
    - b. All Other Parts: Stainless steel.
  - 3. Coordinate placement of extra heavy-duty overhead holder and stop with weatherstripping for non-interference.
  - 4. Design and reinforce connections of extra heavy-duty holder and tops where they are fasteners to other materials, to resist a superimposed load of 30 pounds per square foot acting on the plane of the doors. Mount to door using a minimum of four countersunk mounting holes with four 3/8-inch diameter stainless steel sex bolts.
  - 5. Provide all manufacturer recommended door reinforcements and coordinate the furnishing of hardware templates required for the installation of the units.
  - 6. Finish: US 32D stainless steel, satin finish.
- K. Flush Bolts And Automatic Flush Bolts
- 1. Provide flush bolts on the inactive leaf of all pairs of doors, unless otherwise specified.
  - 2. Provide flush bolts at the top and bottom of door.
  - 3. Materials: Provide the following materials:
    - a. Flush Bolt Levers: Forged Brass.
    - b. Flush Bolt Plate: Forge Brass.
    - c. Flush Bolt Guide and Strike: Wrought Brass.
    - d. Flush Bolt Rods: 1/2-inch round rods, bronze, 12-inch minimum length.

## GENERAL SPECIFICATION 08710 - FINISH HARDWARE

---

4. Provide extension flush bolts with 3/4 inch throws and with top bolt not over 6 foot-0 inches above finished floor. Provide bottom flush bolt 12-inches long.
  5. Where required by governing authorities provide cast bronze automatic flush bolts bearing the UL label.
- L. Coordinators
1. Provide coordinator device on all pairs of doors required or specified to have automatic flush bolts, or panic exit devices. Comply with UL, List of Inspected Fired Protection Equipment and Material, and NFPA No. 80 requirements.
  2. Provide manufacturer's standard carry bar and strike on all pairs of doors equipped with coordinator.
  3. Materials: Bronze.
  4. Finish: US 32D Satin Stainless Steel.
- M. Astragals
1. Provide metal astragal bar, not less than 1/8-inch by 2-inches, for exposed flathead screw mounting on active leaf of all pairs of doors.
  2. Provide astragal of extruded aluminum with clear anodized finish.
- N. Dust-Proof Strikes
1. Provide brass dust-proof strikes which incorporate a slotted plunger raised to flush position by spring tension for all flush bolts.
  2. Provide 5/8-inch inside diameter dust-proof strikes; threshold mounted and surface mounted.
  3. Finish: US 26D Satin Chrome.
- O. Magnetic Monitor Switch
1. Provide stainless steel magnetic monitor switch which incorporates a magnet set into the door leaf head and an actuator set into the corresponding position in the frame which will electronically monitor the door leaf position.
  2. Provide magnetic monitor switch; flush (full mortized) mounted into frame and door leaf head.
  3. Finish: US 4.
- P. Weatherstripping And Acoustic Seals

1. Provide perimeter weatherstripping at all exterior doors. Provide acoustic stripping and seals for interior doors where scheduled.
2. Continuity of Stripping: Except as otherwise specified, it is required that the stripping at each opening be continuous and without unnecessary interruptions at door corners and hardware.
3. Replaceable Seal Strips: It is required that the resilient or flexible seal strip of every unit be easily replaceable and readily available from stocks maintained by the manufacturer.
4. Provide bumper-type weatherstripping at jambs and head, including a resilient insert and metal retainer strip, surface-applied of the following metal, finish and resilient bumper material:
  - a. Housing: Extruded aluminum with clear anodized finish; 0.062-inch minimum thickness of main walls and flanges.
  - b. Dimensions: 1-1/2 inches by 15/16-inches; stop-mounted.
  - c. Seals: Closed-cell extruded sponge neoprene.
5. Provide heavy-duty automatic acoustic drop-seal sound-stripping door-bottom unit with threshold of manufacturer's standard design, with operating seal bar of the following material, retained in an extruded metal bar, and capable of operating to close a 1-inch gap (from door bottom to floor or threshold). House mechanism and operating bar in the following metal housing, for mounting on doors as follows:
  - a. Housing: Extruded aluminum, 0.062-inch thick, with clear anodized finish on exposed surfaces.
  - b. Seal: Closed-cell sponge neoprene.
  - c. Mounting: Semi-mortise. Mount on stop-face of doors, except mount on bing-face of swing-in exterior doors.

**Q. Thresholds**

1. Thresholds for all exterior doors shall be supplied by custom entry door system manufacturer. All interior doors shall be provided with thresholds.
2. Metal: Extruded aluminum; custom satin brushed aluminum; US 26 finish.
3. Surface Pattern: Fluted tread, manufacturer's standard.

## GENERAL SPECIFICATION 08710 - FINISH HARDWARE

---

4. Provide countersunk stainless steel screws and expansion shields.
  5. Width: 5-inches wide and of length sufficient to span full width of rough openings; coped and scribed neatly at and around door frames.
  6. Construction:
    - a. Single-piece, complying with manufacturer's recommendations.
  7. Profile: Provide manufacturer's unit which conforms to the minimum size and profile requirements specified.
  8. Coordinate thresholds for full compatibility with recessed floor mounted closers.
  9. Thickness: 1/2 inch minimum.
- R. Offset Thresholds
1. Thresholds for custom entry door system doors shall be supplied by custom entry door system manufacturer. All doors shall be provided with thresholds of the types specified herein.
  2. Metal: Extruded aluminum; custom satin brushed aluminum; US 26 finish.
  3. Surface Pattern: Fluted tread, manufacturer's standard.
  4. Provide countersunk stainless steel screws and expansion shields.
  5. Width: 7-3/4 inches and 8-3/4-inches wide and of length sufficient to span full width of rough openings; coped and scribed neatly at and around door frames.
  6. Construction:
    - a. Single-piece, complying with manufacturer's recommendations.
    - b. When threshold abuts a wall at the ends, provide straight ends substituted for mitered returns.
  7. Profile: Provide manufacturer's unit which conforms to the minimum size and profile requirement specified.
  8. Coordinate thresholds for full compatibility with recessed floor mounted closers and with 1/2-inch thick polyacrylate terrazzo at all locations of step down conditions.
  9. Thickness: 1/2-inch minimum.



- S. Silencers
  - 1. Provide silencers for all door frames.
  - 2. Provide pneumatic design that once installed, forms an air pocket to reduce noise.
  - 3. Provide minimum of three per strike side of door jambs.
- T. Stops
  - 1. Stops shall be semi-automatic cast bronze extra heavy-duty floor mounted door holder, one per leaf.
  - 2. Activation of holder accomplished by flipping engagement tongue forward. Release by firmly pushing door.
- U. Sealants
  - 1. Provide butyl rubber sealant complying with ASTM C920 for use with thresholds.
  - 2. Adhesives, sealants, and primers, shall comply with VOC limits established by City standards or other local restrictions, as applicable.
- V. Hardware Finishes
  - 1. Provide matching finishes for hardware units at each door or opening, to the greatest extent possible. Reduce difference in color and textures as much as commercially possible where the base metal or metal forming process is different for individual units of finish hardware exposed at the same door or opening. In general, match all items to the manufacturer's standard finish for the latch set for color and texture.

**PART 3 EXECUTION**

**3.01 EXAMINATION**

- A. The Contractor, installer and architectural hardware consultant shall examine the substrate to receive finish hardware, and ascertain the conditions under which the work will be performed, and notify Engineer in writing of unsatisfactory conditions. Do not proceed with the finish hardware Work until unsatisfactory conditions have been corrected in a manner acceptable to the Engineer.

**3.02 PREPARATION**

- A. Templates: Furnish finish hardware templates to each fabricator of doors, frames and other work to be factory-prepared for the installation of finish hardware. Upon request, check the Shop Drawings of such

other work, to confirm that adequate provisions are made for the proper installation of the finish hardware.

3.03 INSTALLATION

- A. Mount finish hardware units at heights recommended in "Recommended Locations for Builders' Hardware" by National Builders Hardware Association, except as otherwise specified or required to comply with governing regulations.
- B. Install each finish hardware item in compliance with the manufacturer's instructions and recommendations.
- C. Set units level, plumb and true to line and locations. Adjust and reinforce the attachment substrate as necessary for proper installation and operation.
- D. Drill and countersink units which are not factory-prepared for anchorage fasteners. Space fasteners and anchors in accordance with industry standards.
- E. Cut and fit threshold and floor covers to profile of door frames, and recessed floor mounted closers with mitered corners and hair-line joints. Join units with concealed welds or concealed mechanical joints. Cut smooth openings for spindles, bolts and similar items, if any.
- F. Screw thresholds to substrate with No. 10 or larger stainless steel screws of the proper type for permanent anchorage.
- G. Set thresholds in a bead of butyl rubber sealant to completely fill concealed voids and exclude moisture from every source. Do not plug drainage holes or block weeps. Remove excess sealant before sealant cures to a firm set.

3.04 FIELD QUALITY CONTROL

- A. Provide a written field report, prepared by installer's architectural hardware consultant, identifying actual condition, location, manufacturer, and product designation for each item of finish hardware actually present on each door at the Site, including whether finish hardware is adjusted and operating properly. Compare actual units present with each item referenced to the approved Shop Drawings and Contract requirements.
- B. Installer's architectural finish hardware consultant shall provide opinions to, and assist the Engineer in determining, acceptability of installation as work proceeds. All comments and discussions, conversations and meetings with the Engineer shall be included in written field report for submission to the Engineer for review and approval at completion of finish hardware installation.

- C. As part of written field report to be submitted to the Engineer for approval, recommend remedial actions for work not in compliance with the Sections. No payment for remedial action shall be made until remedial recommendations and actions have been approved by the Engineer and incorporated into the Work.

3.05 ADJUSTMENT AND CLEANING

- A. Provide a Final Report on the actual finish hardware present on each door of the work. Compare this field Report to approved Shop Drawings submittal and present to the Engineer with remedial recommendations. No payment for remedial action shall be made until remedial recommendations have been approved by the Engineer and implemented by the Contractor.
- B. Adjust and check each operating item of finish hardware and each door to ensure proper operation or function of every unit. Lubricate moving parts with the type lubrication recommended by manufacturer (graphite-type if no other recommended). Replace units which cannot be adjusted and lubricated to operate freely and smoothly as intended for the application.
- C. Final Adjustment: Where finish hardware installation is made more than one month prior to Final Acceptance or occupancy of a space or area, return to the Work during the week prior to Final Acceptance or occupancy, and make a final check and adjustment of all finish hardware items in such space or area. Clean and relubricate operating items as necessary to restore proper function and finish of finish hardware and doors. Adjust door control devices to compensate for final operating of heating and ventilating equipment.
- D. Provide each manufacturer's authorized technical representative to instruct and train the City's personnel in proper adjustment and maintenance of finish hardware during the final adjustment of finish hardware.
- E. Finish hardware which is blemished or defective will be rejected even though it was set in place before defects were discovered. Remove and replace with new finish hardware. Repair all resultant damage to other work.
- F. Continued Maintenance Service: Approximately 6 months after the acceptance of finish hardware in each area, the installer, accompanied by the representative of the latch and lock manufacturer, shall return to the project and readjust every item of hardware to restore proper function of doors and finish hardware. Consult with and instruct City's personnel in recommended additions to the maintenance procedure. Clean and lubricate operational items wherever required. Replace finish

## **GENERAL SPECIFICATION 08710 - FINISH HARDWARE**

---

hardware items which have deteriorated or failed due to faulty design, materials or installation of finish hardware units. Prepare a written report of current and predictable problems (of substantial nature) in the performance of the finish hardware.

### 3.06 SCHEDULES

- A. Prepare finish hardware schedule for approval of the Engineer based on requirements of Contract Documents.

END OF SECTION

**SECTION 08800  
Glass, Plastic and Glazing**

**PART 1 GENERAL**

**1.01 SUMMARY**

- A. Furnishing all labor, materials, equipment and appliances required for the complete execution of work as shown on the Contract Drawings and specified herein and in the Detailed Specifications.
- B. Principal items of work include:
  - 1. Float glass
  - 2. Insulated glass
  - 3. Clear plate wire glass
  - 4. Glazing clips, tapes, gaskets and compound
  - 5. Setting glass and glazing
  - 6. Laminated Safety Glass
- C. The Contractor shall implement practices and procedures to meet the project's sustainability goals as identified in the Contract Documents. The Contractor shall ensure that the sustainability requirements of this Section are implemented to the fullest extent.
- D. The following index of this Section is presented for convenience:

<u>Article</u>	<u>Title</u>	<u>Page</u>
		08800-
PART 1	GENERAL .....	1
1.01	Summary .....	1
1.02	Payment.....	2
1.03	References.....	2
1.04	System Design Requirements .....	3
1.05	Quality Assurance.....	3
1.06	Submittals .....	4
1.07	Delivery, Storage And Handling.....	5
1.08	Project Conditions.....	6
1.09	Warranty .....	6
PART 2	PRODUCTS.....	6
2.01	Acceptable Manufacturers .....	6
2.02	Materials, General.....	6
2.03	Glazing Materials.....	9

**GENERAL SPECIFICATION 08800 - GLASS, PLASTIC AND GLAZING**

PART 3 EXECUTION.....10  
3.01 Installation.....10  
3.02 Protection And Cleaning.....10

1.02 PAYMENT

- A. No separate payment will be made for performing any work of this Section and all costs associated thereof shall be included in the lump sum price bid for the Contract, except as provided for in the Detailed Specifications.

1.03 REFERENCES

- A. NYCBC -- New York City Building Code
- B. CPSC 16 CFR 1201 -- Federal Safety Standard for Architectural Glazing Materials
- C. ANSI Z97.1 -- Performance Specifications and Methods of Test for Safety Glazing Material Used in Buildings
- D. GANA Glazing Manual -- Glass Association of North America, Glazing Manual
- E. IGMA TM-4000-02(07) -- Insulating Glass Manufacturing Quality Procedure Manual.
- F. ASTM C1036 -- Standard Specification for Flat Glass
- G. UL 9 -- Standard for Fire Tests of Window Assemblies
- H. NFPA 252 -- National Fire Protection Association, Standard Method of Fire Tests for Door Assemblies
- I. NFPA 257 -- National Fire Protection Association, Standard Method of Fire Tests for Window and Glass Block Assemblies
- J. ASTM C509 -- Standard Specification for Elastomeric Cellular Preformed Gasket and Sealing Material
- K. ASTM E119 -- Standard Test Methods for Fire Tests of Building Construction and Materials

1.04 SYSTEM DESIGN REQUIREMENTS

A. Glass Sizes and Types

1. Each light of glass shall bear the manufacturer's label, showing kind, thickness and quality and the label shall not be removed until the work has been inspected and approved by the Engineer.
2. All glass shall be the best quality of its respective kind, free from integral or surface defects and shall not be clouded, cracked or broken.

B. Sustainable Design Requirements

1. Recycled Content of Glass: Postconsumer recycled content plus one-half of preconsumer recycled content shall not be less than 10 percent.
2. Low Emitting Materials: Sealants and adhesives used on site and within the building's weatherproofing system shall meet the VOC content limits listed below or in the detail specifications.
  - a. Architectural Sealants: 250 g/L.
  - b. Sealant Primers for Nonporous Substrates: 250 g/L.
  - c. Sealant Primers for Porous Substrates: 775 g/L.
  - d. Multipurpose Construction Adhesives: 70 g/L
  - e. Structural Glazing Adhesive: 100 g/L.

1.05 QUALITY ASSURANCE

- A. In addition to complying with pertinent codes, regulations and safety standards, comply with the recommendations contained in the "Manual of Glazing" of the Flat Glass Marketing Association.
- B. Provide at least one person who shall be thoroughly trained and experienced in the skills required, who shall be completely familiar with the referenced standards and the requirements of the Contract Documents, and who shall personally direct all installations performed under this Section.
- C. Coordinate with the various glass, door and window manufacturers to ascertain the proper type of glazing compounds to be used so that all design criteria are met and so that the required manufacturers' guarantees are not invalidated.
- D. IGCC Certification- Insulating Glass Certification Program: Provide insulating glass units complying with requirements indicated which are permanently marked with certification label.

## **GENERAL SPECIFICATION 08800 - GLASS, PLASTIC AND GLAZING**

- E. Glass thickness specified shall be considered as minimum values and that thicker glass or wider insulating spaces, or both, may be required by door and window manufacturers in order to produce a product, which meets the thermal requirements specified in other Sections. Secure and coordinate all requirements from each manufacturer prior to ordering or installing such items.
- F. All glass shall be factory labeled on each pane and shall contain, as a minimum, grade, type and quality of glass and trademark. Glass without factory labels shall be considered unacceptable. After inspection and approval by Engineer, remove labels from all glass.
- G. Check openings to verify that frames are plumb and true, square and secure. Clean surfaces to be sealed; perform work under satisfactory weather conditions; provide shelter and proper temperature.
- H. Take field dimensions for cutting glass and fabricating units.
- I. All glass sizes shall be determined by measuring the frames to receive the glass at the site and/or from guaranteed dimensions provided by the frame supplier. Glass sizes shall comply with the manufacturer's specified tolerances for each type of glass including cutting tolerance, minimum edge clearance, minimum face clearance, and cover on glass.

### 1.06 SUBMITTALS

- A. Contractor shall submit Shop Drawings for approval of the Engineer. Submittals shall include, but not be limited to the following:
  - 1. Samples
  - 2. Shop Drawings
- B. Samples shall include:
  - 1. Two 12" square pieces of each type of glass specified.
  - 2. One bead, approximately 1/4 inch wide x 3 inches long of sealant, indicating color and set of cured material.
- C. Shop Drawings shall include but not be limited to:
  - 1. Complete layout and installation drawings and schedules with clearly marked dimensions.
  - 2. Manufacturer's descriptive data of glass and glazing materials.
  - 3. Recommended installation instructions.
  - 4. Manufacturer's certification that the materials meet specification requirements.
- D. Sustainable Design Submittals:



## **GENERAL SPECIFICATION 08800 - GLASS, PLASTIC AND GLAZING**

1. Environmental Materials Reporting Form (EMRF) Recycled Content. Provide the following information:
  - a. Name of Product and Manufacturer.
  - b. Material cost breakdowns. Cost breakdowns must include total material-only cost (excluding installation, labor and equipment).
  - c. The percentage (by weight) of post-consumer and pre-consumer recycled content in the submitted product(s), if applicable.
  - d. Indicate the location and distance from Project of material manufacturer and point of extraction, harvest, or recovery for each raw material. For assemblies, include the percentage by weight that is considered regional.
2. VOC Reporting Form. Provide the following information:
  - a. For all sealants and adhesives used on site and within the building's weatherproofing system provide the VOC content in grams/Liter (g/L) less water and other exempt compounds.

### 1.07 DELIVERY, STORAGE AND HANDLING

- A. Delivered materials shall match to approved samples in every respect. Deliver materials in the manufacturer's original unopened labeled containers, clearly marked with their name and brand. Transport large panes of glass in vertical position with spacers to prevent contact between panes and edges.
- B. Store glass in a dry, well-ventilated location at a constant temperature, maintained above dew point. Handling shall be kept to a minimum and all glass shall be protected from soiling, condensation or moisture of any kind.
- C. Glass delivered to the job site with manufacturer's markings, or when markings are applied at the job, use either neutral or slightly acidic adhesive. In no case shall marking materials or adhesives be alkaline. Any staining of glass by alkaline material will be cause for rejection.
- D. The edges of all tempered and insulating glass shall be protected from damage and edges shall not be modified in any way after the glass leaves the factory. Nipping of any glass to reduce size shall not be permitted.
- E. All glass shall be delivered with manufacturer's labels showing type, thickness and quality of material (and UL label as required). These

## **GENERAL SPECIFICATION 08800 - GLASS, PLASTIC AND GLAZING**

labels shall not be removed until the glass is set and final approval has been secured.

### 1.08 PROJECT CONDITIONS

- A. Perform glazing when ambient temperature is above 40°F.
- B. Perform glazing on dry surfaces only.

### 1.09 WARRANTY

- A. Insulating Glass - Manufacturer shall warranty, for 20 years, to deliver without charge, a replacement for any unit, which develops material obstruction to vision due to film formation or dust collection on the interior glass surfaces resulting from failure of the hermetic seal other than through glass breakage.
- B. Laminated Glass - Manufacturer shall warranty, for 5 years, to deliver without charge, a replacement for any light of laminated glass, which develops edge separation or other defects, which materially obstruct vision through the glass.

## PART 2 PRODUCTS

### 2.01 ACCEPTABLE MANUFACTURERS

- 1. The products accepted as manufactured by:
  - a. PPG Industries, One PPG Place Pittsburgh, PA.
  - b. Libby - Owens – Ford, Toledo, OH.
  - c. Cardinal IG, Eden Prairie, MN.
  - d. Viracon, Inc., Owatonna, MN.
  - e. Guardian, Inc., Webster, MA.
  - f. Or approved equal.

### 2.02 MATERIALS, GENERAL

- A. Unless otherwise specified, all glass shall conform to FS DD-G-451c. ASTM C1036 All product references are Viracon trade names. All substitutions shall perform equal to or better than products specified.
- B. Insulating glass (unit type 1) shall be one and five-eighths (1-5/8) inches thick hermetically sealed units consisting of an outer light of 9/16 inch heat strengthened laminated panels with VH11-50 E Coating System" and an inner light of 9/16 inch thick heat strengthened laminated clear glass, each separated by 1/2 inch entrapped, dehydrated air, edges dual sealed and silicone second sealed. Each panel to have 0.060 clear polyisobutylene (PVB) inner layer.

## **GENERAL SPECIFICATION 08800 - GLASS, PLASTIC AND GLAZING**

1. Transmittance:
    - a. Visible Light: 45%
    - b. Solar Energy: 23%
    - c. Ultraviolet: <1%
      - 1) (Ultraviolet defined as 300 to 380 nanometers (nm))
  2. Reflectance:
    - a. Visible Light-Exterior: 16%
    - b. Visible Light-Interior: 13%
    - c. Solar Energy: 21%
  3. ASHRAE U-Value:
    - a. Winter Nighttime: 0.45 Btu (hr x sq ft x °F)
    - b. Summer Daytime: 0.52 Btu (hr x sq ft x °F)
  4. Shading Coefficient: 0.39
  5. Solar Factor (SHGC): 0.33
  6. Relative Heat Gain: 85 Btu/hr x sqft
- C. Insulated Glass with Obscure Translucent PVB unit (type 2). Same as type 1 except inboard lite to be 9/16 laminated glass with obscure PVB inner layer.
1. Transmittance:
    - a. Visible Light: 45%
    - b. Solar Energy: 23%
    - c. Ultraviolet: <1%
      - 1) (Ultraviolet defined as 300 to 380 nanometers (nm))
  2. Reflectance:
    - a. Visible Light - Exterior: 16%
    - b. Visible Light - Interior: 13%
    - c. Solar Energy: 21%
  3. ASHRAE U-Value:
    - a. Winter Nighttime: 0.46 Btu (hr x sq ft x °F)
    - b. Summer Daytime: 0.56 Btu (hr x sq ft x °F)

## **GENERAL SPECIFICATION 08800 - GLASS, PLASTIC AND GLAZING**

4. Shading Coefficient: 0.39
  5. Solar Factor (SHGC): 0.33
  6. Relative Heat Gain: 85 Btu/hr x sq ft
- D. Insulated Glass Unit (type 3): one and five-eighths (1-5/8) inches thick. Outboard lite: Viracon 9/16 laminated VH 11-50 both lites heat strengthened with BE1028 interlayer. Silkreen 1/8 lines 1/4 o/c with V912 white frit on No. 2 surface. 1/2 airspace. Inboard lite 9/16 clear laminated heat strengthened with .060 clear PVB.
1. Transmittance:
    - a. Visible Light: 28%
    - b. Solar Energy: 14%
    - c. Ultraviolet: <1%
      - 1) (Ultraviolet defined as 300 to 380 nanometers (nm))
  2. Reflectance:
    - a. Visible Light - Exterior: 25%
    - b. Visible Light - Interior: 24%
    - c. Solar Energy: 22%
  3. ASHRAE U-Value:
    - a. Winter Nighttime: 0.45 Btu (hr x sq ft x °F)
    - b. Summer Daytime: 0.53 Btu (hr x sq ft x °F)
  4. Shading Coefficient: 0.29
  5. Solar Factor (SHGC): 0.25
  6. Relative Heat Gain: 65 Btu/hr x sqft
- E. Insulated Spandrel Glass unit (type 4). Same outboard lite as type 2 unit. 1/2 airspace. Inboard lite: 1/4 clear heat strengthened with V 948 frit applied to No. 6 surface of insulated glass unit.
1. ASHRAE U-Value:
    - a. Winter Nighttime: 0.46 Btu (hr x sq ft x °F)
    - b. Summer Daytime: 0.57 Btu (hr x sq ft x °F)
- F. Laminated glass: shall be laminated safety glass, 1/4-inch minimum thickness, interior exposure standard clear laminated glass or approved equal. For use in: interior locations as indicated on the Contract Drawings.

## **GENERAL SPECIFICATION 08800 - GLASS, PLASTIC AND GLAZING**

- G. Wire Glass - Clear window glass with 3/4-inch square mesh welded wire reinforcing imbedded in glass. Clear plate wire glass shall be 1/4 inch thick similar and equal to "Smooth Wire" as manufactured by Guardian, Inc., and shall be used for: Vision panels in doors, or as indicated on the Contract Drawings.
- H. Tempered Figured/Patterned Glass: Kind FT, Condition A, Type II, Class I, Quality q8, Finish f1 of pattern and class indicated.
- I. Fire Rated Glazing System - ASTM E119 UL to be located as indicated on the Contract Drawings of a minimum of 1/4-inch thickness, indicated in fire rated assemblies in doors, sidelights or windows unless noted otherwise as manufactured by SAFTI (Safety and Fire Technology, Inc.) Listed as follows:
  - 1. SuperLite II 90 28/28 glazing wall and door system UL Design #U518. Maximum vision area 28 square feet, 90 minute fire rate assembly. Sponsors: SAFTI and O'Keefe/GPX.
  - 2. SuperLite II-45 Door, window or sidelight ASTM E163 and E152 UL Design #R14212 Sponsors SAFTI and CECO.
  - 3. SuperLite II 60 28 glazing wall system with GPX frame. ASTM E119 UL Design #U518. Sponsors SAFTI and O'Keefe/GPX.
- J. Clear Heat-Strengthened Float Glass: Kind HS, Condition A, Type I, Class 1, Quality q3.
- K. Clear Float Glass - Type I, Class 1, Quality g3.

### 2.03 GLAZING MATERIALS

- A. Use a resilient, non-hardening glazing compound, capable of withstanding the climatic conditions at the Project site, such as silicone or polysulfide sealants.
- B. Secure recommendations from window and glass manufacturers as to the proper type of glazing compound, which should be used so as not to delaminate glass, stain materials or otherwise create defects in the work.
  - 1. Make exposed surfaces smooth, even and uniform in appearance. Slope glazing compound to readily shed water.
  - 2. Glazing compound for glazing metal sash, doors, etc., shall meet the requirements of ASTM E119 respectively for physical qualities and shall be as manufactured by:
    - a. H.B. Fred Kuhls, Brooklyn, NY.
    - b. Tremco Manufacturing Co., Beachwood, OH.
    - c. Pecora Paint Co., Harleysville, PA.

## **GENERAL SPECIFICATION 08800 - GLASS, PLASTIC AND GLAZING**

- d. Gibbs and Hohman, Munster, IN.
- e. Or approved equal.
- 3. Preformed vision strips and tape shall be used in conjunction with setting all glass in exterior windows and shall be similar and equal to Tremco vision strips and "Tremco 440" Tape as manufactured by:
  - a. Tremco Manufacturing Co., Beachwood, OH.
  - b. Or approved equal.

Tapes and vision strips shall be as selected from the manufacturer's standard products.

### **PART 3 EXECUTION**

#### **3.01 INSTALLATION**

- A. Sheet glass shall be cut and set with waves running horizontally.
- B. All measurements and size for the work shall be obtained and verified by the Contractor who shall be responsible for the correct and accurate fitting of all his work.
- C. All glass shall be set in such manner as to avoid possibility of breakage.
- D. Rabbets shall be thoroughly cleaned and shall have been prime coated before glass is set.
- E. Glass shall be well bedded and back glazed and all surplus compound and markings shall be carefully removed from doors, sash and adjoining work, while still fresh. Compound shall be finished in true, even lines, neatly and smooth faced. All glass shall be set in strict accordance with the manufacturer's printed directions.
- F. All glass when set and glazed shall be free from rattle and all exterior glazing shall be executed in such a manner that the work will be watertight. Insulating glass shall be set in compliance with the manufacturer's instructions.
- G. Glazing molds shall be removed and replaced in their correct locations in such a manner as not to mar molding or the screws securing same.
- H. All glazing shall be done at the building after the work into which glass is to be set has been installed. All openings shall be properly marked after being installed, to show that the openings have been glazed.

#### **3.02 PROTECTION AND CLEANING**

- A. Before and after installation, all work shall be properly protected against damage.

## **GENERAL SPECIFICATION 08800 - GLASS, PLASTIC AND GLAZING**

- B. On completion and prior to turning the project over to the City, all metal work and glass shall be cleaned and left in perfect condition. Glass shall be washed outside and inside.
- C. Make required adjustments.
- D. Thoroughly clean all glass and mirrors just before final acceptance by the City, or sooner if authorized by Engineer.
- E. Remove excess glazing compound and foreign materials.
- F. Replace broken or defective glass and hardened, uneven, defective or otherwise non-complying glazing compound.

END OF SECTION

NO TEXT ON THIS PAGE



**SECTION 09206  
Metal Furring and Lathing**

**PART 1 GENERAL**

**1.01 SUMMARY**

- A. Metal furring and lathing as specified herein include wall framing, bulkhead framing, ceiling framing, furred space framing, metal lathing, and all accessories and appurtenances.
- B. Metal furring and lathing shall be provided as indicated on the Contract Drawings, specified herein and in the Detailed Specifications, or as required otherwise for a complete installation.
- C. The Contractor shall implement practices and procedures to meet the project's sustainability goals as identified in the Contract Documents. The Contractor shall ensure that the sustainability requirements of this Section are implemented to the fullest extent.
- D. The following index of this Section is included for convenience:

<u>Article</u>	<u>Title</u>	<u>Page</u>
		09206-
PART 1	GENERAL.....	1
1.01	Summary.....	1
1.02	Payment.....	2
1.03	Related Sections.....	2
1.04	References.....	2
1.05	System Design Requirements.....	2
1.06	Quality Assurance.....	3
1.07	Submittals.....	3
1.08	Delivery, Storage And Handling.....	4
PART 2	PRODUCTS.....	4
2.01	Manufacturers.....	4
2.02	Materials.....	5
PART 3	EXECUTION.....	6
3.01	Examination.....	6
3.02	Installation.....	6
3.03	Protection.....	8
3.04	Adjustment.....	8

## **GENERAL SPECIFICATION 09206 -METAL FURRING AND LATHING**

### 1.02 PAYMENT

- A. No separate payment will be made for any work of this Section and all costs thereof shall be included in the lump sum price bid for the Work, except as otherwise provided for in the Detailed Specifications.

### 1.03 RELATED SECTIONS

- A. General Specification 05081 - Galvanizing
- B. General Specification 07900 - Caulking and Sealants

### 1.04 REFERENCES

- A. ASTM C841 - Standard Specification for Installation of Interior Lathing and Furring
- B. ASTM C847 - Standard Specification for Metal Lath
- C. ASTM C1002 - Standard Specification for Steel Self-Piercing Tapping Screws for the Application of Gypsum Board or Metal Plaster Bases to wood studs or steel studs
- D. ASTM C1063 - Standard Specification for Installation of Lathing and Furring to receive interior and exterior Portland Cement-Based Plaster
- E. GA-600-09 - Gypsum Association Fire Resistance Design Manual
- F. ML/SFA 540 - (Metal Lath/Steel Framing Association, Division of National Association of Architectural Metal Manufacturers) Lightweight Steel Framing systems Manual
- G. ML/SFA 920 - Guide Specifications for Metal Lath and Furring
- H. U.L. - Fire Resistance Directory and Building Material Directory
- I. New York City Building Code

### 1.05 SYSTEM DESIGN REQUIREMENTS

- A. Vertical Finish Surface Deflection: Wall and furred space framing shall be limited to a surface deflection of 1:360 under a lateral point load of 100 pounds.
- B. Horizontal Finish Surface Deflection: Ceiling and soffit framing shall be limited to a surface deflection of 1:360 under superimposed dead loads and wind uplift.

## GENERAL SPECIFICATION 09206 - METAL FURRING AND LATHING

- C. Fire rated assemblies shall conform to ASTM E119 and all applicable codes.
  - D. Sustainable Design Requirements
    - 1. Recycled Content of Metal Lath and Metal Accessories: Postconsumer recycled content plus one-half of pre-consumer recycled content not less than 25 percent.
  - E. Project-specific system/design requirements will be provided (if necessary) in the Detailed Specifications in order to update the requirements given herein or to supplement other requirements given in the Contract Drawings.
- 1.06 QUALITY ASSURANCE
- A. All metal furring and lathing work shall be performed in accordance with ASTM C841, ASTM C847, ASTM C1063, GA-600, ML/SFA 540, and ML/SFA 920. The Contractor shall maintain one copy of each of the aforementioned documents on site.
- 1.07 SUBMITTALS
- A. Contractor shall submit Shop Drawings for approval of the Engineer. Submittals shall include, but not be limited to: catalog cuts, drawings, and reference materials.
    - 1. Submittals shall include the following:
      - a. Data: The Contractor shall submit copies of specifications, installation instructions and general recommendations from the metal furring and metal lath manufacturers, for each type of product.
      - b. Manufacturer's data substantiating that the materials comply with the requirements shall be included.
    - 2. Test Reports: Test data shall be submitted:
      - a. All fire rated systems at no additional cost to the City.
    - 3. Sustainable Design Submittals:
      - a. Environmental Materials Reporting Form (EMRF) Recycled Content and Regional Materials. Provide the following information:
        - 1) Name of Product and Manufacturer.
        - 2) Material cost breakdowns. Cost breakdowns must include total material-only cost (excluding installation, labor and equipment).

## **GENERAL SPECIFICATION 09206 -METAL FURRING AND LATHING**

- 3) The percentage (by weight) of post-consumer and pre-consumer recycled content in the submitted product(s), if applicable.

### 1.08 DELIVERY, STORAGE AND HANDLING

#### A. Delivery of Materials

1. Materials shall not be delivered to the project site before the time of installation.
2. Materials shall be delivered in sufficient quantities to allow continuity of the Work.

#### B. Storage of Materials

1. Materials shall be stored in original, undamaged containers and packaging with manufacturer's labels and seals intact.
2. All materials shall be stored in a dry, enclosed area, off the ground and away from all possible contact with water, ice or snow.
3. Damage to materials during storage shall be prevented primarily by minimizing the amount of time they are stored at the job-site before being incorporated into construction systems.

#### C. Handling of Materials

1. Materials shall be handled carefully in order to avoid damage or breakage.
2. Materials shall not be exposed to detrimental conditions or physical damage. Materials which are so exposed shall be removed from the site and shall not be incorporated into the Work.
3. Packages or containers shall not be opened until all necessary preparatory Work is complete and installation is to begin immediately. Materials shall not be allowed to become wet or soiled or covered with ice or snow.

## PART 2 PRODUCTS

### 2.01 MANUFACTURERS

- A. Metal Furring and Lathing manufacturers shall be as specified in the Detailed Specifications.

## **GENERAL SPECIFICATION 09206 - METAL FURRING AND LATHING**

### 2.02 MATERIALS

- A. Galvanizing: All steel items included as a part of the metal furring and lathing system shall be galvanized in accordance with General Specification 05081 - Galvanizing, unless specified otherwise.
- B. Furring channels shall be of formed galvanized steel, minimum 0.040-inch thick, 3/8 inches deep by 7/8 inches high. Splicing shall be permitted.
- C. Structural system for suspended ceilings shall be rigidly mounted to the structure above and shall consist of 1-1/2-inch cold rolled galvanized steel 0.475 lb. channels clipped to 1/4-inch diameter galvanized steel rod hangers.
- D. Main ceiling channels shall be of formed galvanized steel, minimum 0.05-inch thick, 3/4 inches deep by 1-1/2 inches high. Ceiling channels shall be a single piece; splicing shall not be allowed.
- E. Hangers and Support for Suspended Ceilings: Ceiling suspension system shall be connected directly to the structural suspension system with galvanized direct hang clips of galvanized rolled steel sections of size and type to suit application.
- F. Casing bead shall be of formed galvanized steel of a depth as required by the plaster thickness and in the maximum possible lengths. Casing bead shall have expanded metal flanges with square edges.
- G. Corner bead shall be of formed galvanized steel of a depth as required by the plaster thickness and in the maximum possible lengths. Corner bead shall have expanded metal flanges with radiused edges.
- H. Base screed shall be of formed galvanized steel of a depth as required by the plaster thickness and in the maximum possible lengths. Base screed shall have expanded metal flanges with beveled edge.
- I. Expansion Joint Accessories: Expansion joint shall be of formed galvanized steel and shall have an accordion profile, two-inch, with expanded metal flanges on each side.
- J. Metal lath shall conform to ASTM C847, and shall be galvanized flat diamond mesh weighing a minimum of 3.4 pounds per square yard.
- K. Corner mesh shall be of formed galvanized steel sheet, minimum 0.018 inches thick with expanded metal flanges, two-inch, shaped to permit complete embedding in plaster.
- L. Strip mesh shall be of formed galvanized steel sheet, minimum 0.018 inches thick by 24 inches wide.

## **GENERAL SPECIFICATION 09206 -METAL FURRING AND LATHING**

- M. Fasteners shall conform to ASTM C1002 and shall be of the selfdrilling, selftapping type.
- N. Polyethylene sheet shall be clear and shall be 6 mil thick.
- O. Tie wire, where required, shall be of 18 gauge stainless steel.

### **PART 3 EXECUTION**

#### **3.01 EXAMINATION**

- A. The Contractor shall verify that areas to receive metal furring and lathing are properly prepared and completed to final elevations.

#### **3.02 INSTALLATION**

##### **A. Wall and Furred Space Framing**

1. General: Lathing and furring for plaster work shall be installed in accordance with ASTM C1063.
2. Attachment: Wall furring shall be attached directly to masonry or concrete walls.
3. Erection: Furring channels shall be erected vertically and shall be secured to walls with fasteners on alternate channel flanges spaced at a maximum of 24 inches on center.
4. Spacing: Furring channels shall be spaced at a maximum of 16 inches on center, and furring channels shall be not more than 4 inches from abutting walls.

##### **B. Ceiling and Soffit Framing**

1. General: Ceiling and soffit framing shall be erected after all work above ceiling or soffit is complete. Furring shall be installed independent of walls, columns, and above ceiling work.
2. Structural Anchorage: Structural suspension system shall be securely anchored to structural members above or embedded in structural slab.
3. Ceiling suspension system shall be securely and rigidly anchored to the structural suspension system with rigid hangers spaced to achieve deflection limits as specified herein.
4. Spacing: Main carrying channels shall be spaced at a maximum of 6 feet on center, and not more than 6 inches from walls. Channels shall be lap spliced securely.
5. Furring: Furring channels shall be placed perpendicular to carrying channels and shall be not more than 2 inches from perimeter walls. Channels shall be lap spliced securely.

## **GENERAL SPECIFICATION 09206 - METAL FURRING AND LATHING**

6. Openings in suspension system which interrupt main carrying channels or furring channels shall be reinforced with lateral channel bracing. Bracing shall extend a minimum of 24 inches past each opening.
  7. Bracing: Ceiling and soffit suspension systems shall be laterally braced.
- C. Control and Expansion Joints
1. Control joints shall be installed using back to back casing beads set 1/4-inch apart, and filled with sealant as specified in General Specification 07900 – Caulking and Sealants. Where required, both beads shall be set over a 6-inch wide strip of polyethylene to assist with air seal.
  2. Spacing: Control joints shall be installed at intervals not to exceed 12 feet.
  3. Expansion joints of the type specified herein shall be installed where expansion joints are shown on the Contract Drawings.
- D. Lathing
1. General: Metal lath shall be applied taut, and shall have the long dimension perpendicular to the supports.
  2. Laps: Lathing ends shall be lapped a minimum of 1 inch, and secure with tie wire where they occur between supports. Sides of diamond mesh shall be lapped a minimum of 1-1/2 inches.
  3. Attachment: Metal lath shall be attached to metal supports using tie wire spaced at not more than 6 inches on center.
  4. Reinforcing: Additional reinforcing is required as follows:
    - a. Internal angles shall be continuously reinforced with corner mesh, fastened at perimeter edges only. Corner mesh is not required where metal lath returns 3 inches from the corner.
    - b. Lath shall be placed vertically above each top corner and each side of door and borrowed light frame, and shall extend to 6 inches above the ceiling.
    - c. Additional strip mesh shall be placed diagonally at corners of all lathed openings, and rigidly secured in place.
  5. Corner beads shall be placed at exterior corners and shall be fastened at outer edges of lath only.

## **GENERAL SPECIFICATION 09206 -METAL FURRING AND LATHING**

6. Base screeds shall be placed at termination of plaster areas and rigidly secured in place.
  7. Dissimilar Backing Materials: At junctions of dissimilar backing materials, 4-inch wide strips of metal lath shall be placed centered over the junction and rigidly secured in place.
  8. Terminations: Casing beads shall be placed at all terminations of plaster finish, and shall be rigidly secured in place.
- E. Tolerances
1. True Lines and Level: The maximum variation in true lines and level shall be 1/8-inch in 10 feet.
  2. True Position: The maximum variation from true position shall be 1/8-inch.

### 3.03 PROTECTION

- A. All components of the Work shall be protected from detrimental weather and damage until construction operations are completed.
- B. Metal furring and lathing work shall be protected from all damage and abuse from all other Contractors and installers involved in the Work until Final Acceptance by the City.

### 3.04 ADJUSTMENT

- A. System components which are dislodged, damaged, expanded, broken, penetrated or crushed for any reason after installation shall be replaced immediately with undamaged material in compliance with the Sections, and properly protected as specified.

END OF SECTION



**SECTION 09250  
Gypsum Board Systems**

**PART 1 GENERAL**

**1.01 SUMMARY**

- A. Gypsum board systems as specified herein include but are not limited to interior and water-resistant wallboard for ceilings and partitions, gypsum board for ceilings and soffits, tile backer board, metal stud partitions, furring, suspension systems, and trim and appurtenances.
- B. Gypsum board systems shall be provided as indicated on the Contract Drawings, specified herein and in the Detailed Specifications, or as required otherwise for a complete installation.
- C. The Contractor shall implement practices and procedures to meet the project’s sustainability goals as identified in the Contract Documents. The Contractor shall ensure that the sustainability requirements of this Section are implemented to the fullest extent.
- D. The following index of this Section is presented for convenience:

<u>Article</u>	<u>Title</u>	<u>Page</u>
		09250-
PART 1	GENERAL .....	1
1.01	Summary .....	1
1.02	Payment.....	2
1.03	Related Sections.....	2
1.04	References.....	2
1.05	System Design Requirements .....	3
1.06	Quality Assurance .....	4
1.07	Submittals .....	5
1.08	Delivery, Storage And Handling.....	6
1.09	Project Conditions.....	6
PART 2	PRODUCTS.....	6
2.01	Manufacturers .....	6
2.02	Materials .....	7
PART 3	EXECUTION.....	8
3.01	Preparation .....	8
3.02	Installation.....	8
3.03	Protection .....	10
3.04	Adjustment.....	10
3.05	Cleaning .....	10

## **GENERAL SPECIFICATION 09250 - GYPSUM BOARD SYSTEMS**

---

### 1.02 PAYMENT

- A. No separate payment will be made for performing any work of this section; the Contractor shall include all costs for the work to be performed in its lump sum price bid for the Contract, except as provided for in the Detailed Specifications.

### 1.03 RELATED SECTIONS

- A. General Specification 05081 - Galvanizing
- B. General Specification 09900 - Painting

### 1.04 REFERENCES

- A. ASTM C1396 - Standard Specification for Gypsum Board
- B. ASTM A580 - Standard Specification for Stainless Steel Wire
- C. ASTM C475 - Standard Specification for Joint Compound and Joint Tape for Finishing Gypsum Board
- D. ASTM C645 - Standard Specification for Nonstructural Steel Framing Members
- E. ASTM C754 - Standard Specification for Installation of Steel Framing Members to Receive Screw-Attached Gypsum Panel Products
- F. ASTM C840 - Standard Specification for Application and Finishing of Gypsum Board
- G. ASTM C1002 - Standard Specification for Steel Self-Piercing Tapping Screws for the Application of Gypsum Panel Products or Metal Plaster Bases to Wood Studs or Steel Studs
- H. ASTM C1047 - Standard Specification for Accessories for Gypsum Wallboard and Gypsum Veneer Base
- I. ASTM C1325 - Standard Specification for Non-Asbestos Fiber-Mat Reinforced Cementitious Backer Units
- J. ASTM D3273 - Standard Test Method for Resistance to Growth of Mold on the Surface of Interior Coatings in an Environmental Chamber
- K. ASTM D3274 - Standard Test Method for Evaluating Degree of Surface Disfigurement of Paint Films by Fungal or Algal Growth, or Soil and Dirt Accumulation

## **GENERAL SPECIFICATION 09250 - GYPSUM BOARD SYSTEMS**

---

- L. ASTM E90 - Standard Test Method for Laboratory Measurement of Airborne Sound Transmission Loss of Building Partitions and elements
- M. ASTM E96 - Standard Test Methods for Water Vapor Transmission of Materials
- N. ASTM E119 - Standard Test Methods for Fire Tests of Building Construction and Materials
- O. ASTM E413 - Classification for Rating Sound Insulation
- P. ANSI A118.9 - American National Standard for Test Methods and Specification for Cementitious Backer Units
- Q. New York City Building Code
- R. Underwriters Laboratories: Fire Resistance Directory and Building Materials Directory.
- S. Northeast Ozone Transport Commission (OTC) Model Rule. The OTC created model AIM VOC rule - Regulated by New York State Department of Environmental Conservation (DEC).

### 1.05 SYSTEM DESIGN REQUIREMENTS

- A. Interior Moisture- and Fire-Resistant Wallboard: Shall meet product standard ASTM C1396 / C1396M and installation standard ASTM C840; fire resistance classified by UL according to ASTM standards; recycled content on a dry-weight basis certified in accordance with ISO 14021.
- B. Sustainable Design Requirements
  1. Recycled Content of Gypsum Panel Products: Postconsumer recycled content plus one-half of preconsumer recycled content not less than 45 percent.
  2. Recycled Content of Steel Products: Postconsumer recycled content plus one-half of preconsumer recycled content not less than 25 percent.
  3. Recycled Content of Sound Attenuation Blankets: Postconsumer recycled content plus one-half of preconsumer recycled content not less than 45 percent.
  4. Regional Materials: When possible, gypsum panel products shall be manufactured within 500 miles of Project site from materials that have been extracted, harvested, or recovered within 500 miles of Project site.

5. VOC Content: Products applied on site and within the building's weatherproofing system shall comply with VOC limits of authorities having jurisdiction and the following VOC limits of when calculated according to SCAQMD Rule 1168:
  - a. Gypsum Board and Panel Adhesives: 50 g/L.
  - b. Architectural Sealants: VOC not more than 250 g/L.
- C. Project-specific system / design requirements under the work of this Section will be provided in the Detailed Specifications (if necessary) to update the requirements made herein or to supplement requirements made on the Contract Drawings.

1.06 QUALITY ASSURANCE

- A. Requirements of Regulatory Agencies: All gypsum board system Work shall comply with fire-resistance ratings as shown, and as required by governing authorities and the New York City Building Code and shall be in accordance with the following requirements:
  1. The Office of Technical Certification and Research (OTCR) of the New York City Department of Buildings: Where, in order to be incorporated into the work, a particular item or product system specified by Engineer requires acceptance by the New York City Commissioner of Buildings, Contractor shall ensure that the product manufacturer has obtained such approval, without additional expense to the City, and in providing the City with an approved certified copy from the Approved Independent Agency, for the item or product system which shall be submitted to Engineer as part of the Shop Drawing approval process. Contractor may submit, in place of products specified by Engineer, products which are "equal" in all ways to the product specified that is NYC code prescribed or alternate the code. Such "or approved equal" product submissions shall not change the requirements of these Sections as to performance, required features or properties, as determined by Engineer, and shall not require additional compensation to Contractor or additional expense to the City. Final acceptance of "equal" is at the sole determination of Engineer.
  2. In those instances where the Commissioner of Buildings requires a certificate of compliance of the manufacturer or producer certifying that the item or product system was tested and is equivalent to material of the same kind and quality regularly being manufactured by such manufacturer or producer Contractor shall provide all such certificates to the

Commissioner of Buildings without additional expense to the City.

1.07 SUBMITTALS

A. The Contractor shall submit Shop Drawings for approval of the Engineer. Submittals shall include, but not be limited to: catalog cuts, drawings, and reference materials.

1. Product Data: The Contractor shall submit:

- a. Copies of specifications, installation instructions and general recommendations from the gypsum board systems manufacturers, for each type of product.
- b. Manufacturer's data substantiating that the materials comply with the requirements shall be included.

2. Sustainable Design Submittals:

- a. Environmental Materials Reporting Form (EMRF) Recycled Content and Regional Materials. Provide the following information:
  - 1) Name of Product and Manufacturer.
  - 2) Material cost breakdowns. Cost breakdowns must include total material-only cost (excluding installation, labor and equipment).
  - 3) The percentage (by weight) of post-consumer and pre-consumer recycled content in the submitted product(s), if applicable.
  - 4) Indicate the location and distance from Project of material manufacturer and point of extraction, harvest, or recovery for each raw material. For assemblies, include the percentage by weight that is considered regional.

3. VOC Reporting Form. Provide the following information:

- a. For all adhesives and sealants used on site, provide the VOC content in grams/Liter (g/L) less water and other exempt compounds.

## **GENERAL SPECIFICATION 09250 - GYPSUM BOARD SYSTEMS**

---

### 1.08 DELIVERY, STORAGE AND HANDLING

#### A. Delivery of Materials:

1. Materials shall not be delivered to the project site before the time of installation.
2. Materials shall be delivered in sufficient quantities to allow continuity of the Work.

#### B. Storage of Materials:

1. Materials shall be stored in original, undamaged containers with manufacturer's labels and seals intact.
2. All materials shall be stored in a dry, enclosed area, off the ground and away from all possible contact with water, ice or snow.
3. Damage to materials during storage shall be prevented primarily by minimizing the amount of time they are stored at the site before being incorporated into construction systems.

#### C. Handling of Materials:

1. Materials shall be handled carefully in order to avoid damage or breakage.
2. Materials shall not be exposed to detrimental conditions or physical damage. Materials which are so exposed shall be removed from the site and shall not be incorporated into the Work.
3. Materials shall be handled in such a manner so as to prevent inclusion of foreign materials.
4. Packages or containers shall not be opened until all necessary preparatory work is complete and installation is to begin immediately. Materials shall not be allowed to become wet or soiled or covered with ice or snow.

### 1.09 PROJECT CONDITIONS

- #### A. Environmental Limitations: Comply with ASTM C 840 requirements or gypsum board manufacturer's written recommendations, whichever are more stringent.

## PART 2 PRODUCTS

### 2.01 MANUFACTURERS

- #### A. Gypsum board systems manufacturer shall be as specified in the Detailed Specifications.

- B. Designations: The products and material designations described herein refer to the products of the United States Gypsum Company, unless otherwise required in the Detailed Specifications or Contract Drawings. These products and designations are given solely for the purpose of indicating the type, materials, strength, quality, and durability of items desired. Products of other manufacturers may be submitted for approval.

2.02 MATERIALS

- A. Gypsum wallboard shall be synthetic wallboard made using the output of the Flue Gas Desulphurization (FGD) process from fossil-fuel burning power plants.
- B. Non-synthetic gypsum board shall be made with 100% recycled paper facings.
- C. Gypsum wall board shall comply with ASTM C 1396/C 1396M.
- D. Gypsum wallboard shall be of the tapered type, Sheetrock Firecode Core 5/8-inch thick, Type X gypsum panels, 4 feet wide, and of lengths indicated or required. 5/8-inch thick Sheetrock Foil-Back gypsum panels shall be provided for use at exterior walls and Firecode C Core gypsum panels shall be provided for fire-rated gypsum wallboard.
- E. Moisture-Resistant Gypsum Board: 5/8-inch thick Sheetrock Mold Tough Gypsum Panels shall be used in interior areas subject to moisture and where indicated.
- F. Tile Backer Board: 1/2-inch thick Durock Cement Board shall be used as a backing for interior ceramic tile at furred and metal stud partitions and walls at shower stalls and other wet areas.
- G. Metal materials and accessories shall be galvanized in accordance with General Specification 05081- Galvanizing unless indicated otherwise.
- H. Studs and tracks shall comply with ASTM C 645 and be 18-gauge steel 3-5/8-inch width for gypsum board, with studs spaced at 16-inch centers. Studs for tile backer board shall be of size recommended by the manufacturer.
- I. Furring Channels and Clips: Furring channels shall be hat type, 7/8-inch by 2-1/2-inch spaced on 16-inch centers, ASTM C 645. Furring channel clips shall be as recommended by the manufacturer to fasten furring channels to runners.
- J. Screws and Fasteners: ASTM C 1002 Type "S-12" coated drywall screws shall be used for attaching gypsum wallboard in lengths 3/8-inch greater than the total thickness of wallboard being fastened to the framing. Size and type of screws for attaching metal door frames and

## GENERAL SPECIFICATION 09250 - GYPSUM BOARD SYSTEMS

---

- runners, metal trim and the like shall be as recommended by the gypsum wallboard manufacturer.
- K. Control Joints, Casing Beads, Corner Beads and Accessories: Materials shall be as required for thickness of the board required, ASTM C1047.
  - L. Hangers for Suspended Ceilings and Soffits: Hangers shall be galvanized steel rod not less than 0.25-inch diameter. Suspended ceilings and soffits shall be rigidly mounted to the structure above.
  - M. Tie wire shall be of 18-gauge stainless steel, ASTM A580 / A580M.
  - N. Runners shall be cold-rolled 1-1/2-inch channels weighing not less than 475 pounds per 1,000 lineal feet, ASTM C 645.
  - O. Joint Treatment: Joint compound, perforated tape, and taping compound shall be as recommended by the manufacturer for intended use of the gypsum board. Comply with ASTM C 475/C 475M
  - P. Adhesives, sealants, and primers shall comply with VOC limits and be as recommended by the gypsum wallboard manufacturer.
  - Q. Acoustical Accessories:
    - 1. RC-1 resilient channels.
    - 2. Sound Attenuation Blankets: ASTM C 665, Type I (blankets without membrane facing) produced by combining thermosetting resins with mineral fibers manufactured from glass, slag wool, or rock wool.
      - a. Basis of Design: Thermafiber SAFB insulation.
    - 3. Sheetrock Acoustical Sealant: Acoustical joint sealant shall have a VOC content of 250 g/L or less when calculated according to 40 CFR 59, Subpart D (EPA Method 24).

### PART 3 EXECUTION

#### 3.01 PREPARATION

- A. The Contractor shall verify that areas to receive gypsum board systems are properly prepared and completed to final elevations.
- B. Protection: In cold weather, during gypsum wallboard application and joint finishing, temperatures within the building shall be maintained in the range of 55 to 70 degrees F and adequately ventilated to remove excess moisture.

#### 3.02 INSTALLATION

- A. General: Gypsum Wallboard System shall be installed in accordance with the manufacturer's recommendations and approved shop drawings.



- B. Wall Furring and Framing Installation: ASTM C 754, Furring channels and runners for metal studs shall be accurately aligned and secured to the structure at intervals of not more than 24-inch centers, and additional fasteners shall be provided not more than 2 inches from the end of each length. Metal studs shall be crimped into runner tracks at top and bottom, both sides, for friction fit with 1/4-inch deflection clearance at the top. Studs shall be securely fastened at ends of partitions, openings, and intersections to runners with screws through both flanges of the stud and runner. Adequate provisions shall be provided for deflection, expansion and contraction between structural members and partitions. Additional studs, reinforcing channels, accessories and total installation shall be as recommended by the manufacturer. Double studs shall be used at free ends of partitions.
- C. Ceiling and Soffit Framing Installation:
1. Gypsum board ceilings and soffits shall be suspended, where shown, from support systems consisting of runner channels and furring channels installed in strict compliance with the manufacturer's printed specifications and recommendations. Runner channels shall be installed at a maximum of 48-inch centers and within 6 inches of parallel walls, and shall be run at right angles to the joists and directly suspended from the concrete deck or joists above with no play in the hanger rods. Hanger spacing shall not exceed 3-foot centers.
  2. Splices in runner channels shall be overlapped a minimum of 12 inches and securely tied near the ends with double loops of tie wire. Furring channels shall be securely clipped to runner channels at right angles and spaced at 24-inch centers. Splices in furring shall be overlapped at least 8 inches and securely tied near the ends with double loops of tie wires.
  3. Framing channels shall be provided around all recessed lighting fixtures and access panels. Stud partitions shall be fastened to ceiling grillage with double strand tie wire.
- D. Wallboard Installation:
1. Comply with ASTM C 840.
  2. Wallboard shall be installed in strict compliance with the manufacturer's printed specifications and recommendations for metal framed dry wall construction, including fireproofing, gypsum wallboard erection, application of joint system, accessories and adhesives. Gypsum wallboard surfaces shall be isolated with control joints at the following locations:

## **GENERAL SPECIFICATION 09250 - GYPSUM BOARD SYSTEMS**

---

- a. Where partitions abut a structural element or dissimilar wall material.
  - b. Where construction changes within the plane of the partition.
  - c. Where partition or furring run exceeds 30 feet.
3. Ceiling height door frames may be used as control joints, and less than ceiling height door frames may be used if control joints extend to the ceiling from both corners of the frame.
  4. Gypsum boards shall be fastened to walls vertically. Joints shall not occur on opposite sides of a partition on the same stud.
  5. Partitions around all stairs and shafts shall have a 2-hour fire rating, comprising double layers of fire-rated gypsum wallboard on each side of the metal stud partition.
  6. All gypsum wallboard surfaces shall be sanded as necessary to provide a flat smooth surface ready for painting or application of other materials.

### **3.03 PROTECTION**

- A. All components of the Work shall be protected from detrimental weather and damage until construction operations are completed and acceptable to Engineer.
- B. Work which cannot for reasons acceptable to Engineer be covered with complete construction system before onset of weather detrimental to the Work shall be completely covered and protected in such a manner as to deflect water and weather from the installation without damaging adjacent work.
- C. Gypsum board systems shall be protected from all damage and abuse until Final Acceptance by the City.

### **3.04 ADJUSTMENT**

- A. System components which are dislodged, damaged, expanded, broken, penetrated or crushed by subsequent installation operations or by detrimental weather shall be immediately replaced with undamaged material in compliance with the Sections and properly protected as specified.

### **3.05 CLEANING**

- A. After installation, gypsum board systems shall be cleaned and left in a neat condition, ready to be painted as specified in General Specification 09900 - Painting or in the Detailed Specifications. Cleaning shall be

## **GENERAL SPECIFICATION 09250 - GYPSUM BOARD SYSTEMS**

---

performed using materials and processes as recommended by the manufacturer.

END OF SECTION

**GENERAL SPECIFICATION 09250 - GYPSUM BOARD SYSTEMS**

---

NO TEXT ON THIS PAGE

**SECTION 09310  
Ceramic Tile**

**PART 1 GENERAL**

**1.01 SECTION INCLUDES**

- A. Ceramic tile as specified herein shall include, but not be limited to, ceramic floor tile, ceramic wall tile, matching base and trim, and appurtenances.
- B. Ceramic tile items shall be provided where shown on the Contract Drawings, specified in the Detailed Specifications, or as required for a complete installation.
- C. The following index of this Section is presented for convenience:

<u>Article</u>	<u>Title</u>	<u>Page</u>
		09310-
PART 1	GENERAL.....	1
1.01	Section Includes.....	1
1.02	Payment.....	1
1.03	References.....	2
1.04	Quality Assurance.....	2
1.05	Environmental Requirements.....	2
1.06	Submittals.....	2
1.07	Delivery, Storage And Handling.....	3
PART 2	PRODUCTS.....	3
2.01	Manufacturers.....	3
2.02	Materials.....	3
PART 3	EXECUTION.....	4
3.01	Examination.....	4
3.02	Installation.....	4
3.03	Protection.....	6
3.04	Adjustment.....	6
3.05	Cleaning.....	6

**1.02 PAYMENT**

- A. No direct payment will be made for ceramic tile items, accessories, or appurtenances; the cost shall be included in the prices for the Work, except as provided for in the Detailed Specifications

## GENERAL SPECIFICATION 09310 - CERAMIC TILE

---

### 1.03 REFERENCES

- A. TCA - Installation Handbook: Tile Council of America, Inc.
- B. ANSI A108.1 - Installation of Ceramic Tile Installed with Portland Cement Mortar, American National Specification for
- C. ANSI A108.5 - Installation of Ceramic Tile with Dry-Set Portland Cement Mortar or Latex-Portland Cement Mortar, American National Specification for
- D. ANSI A108.10 - Installation of Grout in Tile Work
- E. ANSI A118.1 - Dry-Set Portland Cement Mortar
- F. ANSI A118.6 - Ceramic Tile Grouts
- G. ANSI A137.1 - Ceramic Tile

### 1.04 QUALITY ASSURANCE

- A. All Work described in this Section shall be in conformance with the latest edition of the TCA Handbook for Ceramic Tile Installation.

### 1.05 ENVIRONMENTAL REQUIREMENTS

- A. The ambient temperature of the area in which the Work occurs shall be at least 60 degrees F and rising. A minimum 60 degree F ambient temperature shall be maintained without interruption while the Work is being done, and for at least three days after completion of the Work.

### 1.06 SUBMITTALS

- A. Contractor shall submit Shop Drawings for approval of the Engineer. Submittals shall include, but not be limited to: catalog cuts and reference materials.
  - 1. Product Data: The Contractor shall submit:
    - a. Copies of specifications, installation instructions and general recommendations from the ceramic tile manufacturer, for each type of ceramic tile product.
    - b. Manufacturer's data substantiating that the materials comply with the requirements shall be included.
  - 2. Samples:
    - a. Samples of floor and wall tile shall be submitted for color selection.

## GENERAL SPECIFICATION 09310 - CERAMIC TILE

---

### 1.07 DELIVERY, STORAGE AND HANDLING

#### A. Delivery of Materials:

1. Materials shall not be delivered to the project site before the time of installation.
2. Materials shall be delivered in sufficient quantities to allow continuity of the Work.

#### B. Storage of Materials:

1. Materials shall be stored in original, undamaged containers with manufacturer's labels and seals intact.
2. All materials shall be stored in a dry, enclosed area, off the ground and away from all possible contact with water, ice or snow.
3. Damage to materials during storage shall be prevented primarily by minimizing the amount of time they are stored at the site before being incorporated into construction systems.

#### C. Handling of Materials:

1. Materials shall be handled carefully in order to avoid damage or breakage.
2. Materials shall not be exposed to detrimental conditions or physical damage. Materials which are so exposed shall be removed from the site and shall not be incorporated into the Work.
3. Materials shall be handled in such a manner so as to prevent inclusion of foreign materials.
4. Packages or containers shall not be opened until all necessary preparatory Work is complete and installation is to begin immediately. Materials shall not be allowed to become wet or soiled or covered with ice or snow.

## PART 2 PRODUCTS

### 2.01 MANUFACTURERS

- A. Manufacturers shall be as listed in the Detailed Specifications.

### 2.02 MATERIALS

- A. Floor Tile: Ceramic floor tile and paver tile shall be of a size and type as specified in the Detailed Specifications. Surface bull nose to match the floor tile shall be provided to finish the floor where required at

## GENERAL SPECIFICATION 09310 - CERAMIC TILE

---

- finished openings. All floor tile shall be in conformance with ANSI A108.1 and A137.1.
- B. Wall Tile: Ceramic wall tile shall be of a size and type as specified in the Detailed Specifications. Surface bull nose to match the wall tile shall be provided to finish walls where indicated. All wall tile shall be in conformance with ANSI A137.1.
  - C. Bond Coat: Ceramic tile shall be set with dry-set mortar conforming to ANSI A118.1.
  - D. Mortar Bed: Where shown on the Contract Drawings or specified in the Detailed Specifications, mortar bed shall be in accordance with ANSI A108.1A.
  - E. Mortar Bed Bond Coat: Where shown on the Contract Drawings or specified in the Detailed Specifications, mortar bed bond coat shall be a Portland Cement slurry.
  - F. Latex Grout: Latex Portland Cement grout shall conform to ANSI A118.6.
  - G. Epoxy Grout: Epoxy grout shall conform to ANSI A118.3.
  - H. Expansion Joints: Expansion joints shall extend through the bond coat and mortar bed to the substrate, and shall be formed with a material that will bond well to the tile and which will not soften at 140 degrees F or become stiff or hard at minus 30 degrees F. Expansion joint color shall match the color of the grout.

### PART 3 EXECUTION

#### 3.01 EXAMINATION

- A. The Contractor shall verify that areas to receive ceramic tile materials are properly prepared and completed to final grades and elevations.

#### 3.02 INSTALLATION

- A. Thinset Method: Tile shown to be installed by the Thinset Method, shall be installed as follows:
  - 1. Ceramic tile shall be installed by the "dry set mortar" method and shall be in accordance with the TCA Handbook for Ceramic Tile Installation Method No. F113 for floors, Method No. W202 for masonry or concrete walls, and Method No. W243 for gypsum board walls. Tile shall be grouted using latex Portland Cement grout with latex additives. Tile shall be installed in compliance with ANSI A108.5 and A108.10.



## GENERAL SPECIFICATION 09310 - CERAMIC TILE

---

- B. Exterior Patios and Walkways: Floor tile shown to be installed on exterior patios and walkways, shall be installed as follows:
  - 1. Ceramic tile shall be installed in a nominal 1-1/4-inch thick mortar bed and shall be in accordance with the TCA Handbook for Ceramic Tile Installation Method No. F101 for floors. Mortar bed shall be in accordance with ANSI A108.1A. Tile shall be grouted using latex Portland Cement grout with latex additives in accordance with ANSI A118.6. Tile shall be installed in compliance with ANSI A108.5 and A108.10.
- C. Heavy Duty Method: Floor tile shown to be installed in areas subject to heavy traffic, and where shown on the Contract Drawings or specified in the Detailed Specifications, shall be installed as follows:
  - 1. Tile shall be installed in a nominal 1-1/4-inch to 2- inch thick reinforced mortar bed and shall be in accordance with the TCA Handbook for Ceramic Tile Installation Method No. F114 for floors. Mortar bed, reinforcing, and cleavage membrane shall be in accordance with ANSI A108.1A. Tile shall be grouted using epoxy grout in accordance with ANSI A108.6. Tile shall be installed in compliance with ANSI A108.1A and A108.10.
- D. Shower Stalls and Receptors: Ceramic mosaic tile shower walls and receptors shall be installed by the cement mortar method and shall be in accordance with the TCA Handbook for Ceramic Tile Installation Method No. B411 and Method No. B414. Tile shall be grouted using latex Portland Cement grout with latex additives. Tile shall be installed in compliance with ANSI A108.1 and A108.10.
- E. Expansion joints shall be in accordance with the TCA Handbook for Ceramic Tile Installation Method No. EJ171. Expansion joints shall extend from the tile surface completely through the setting bed and shall be of the same width as other joints. Expansion joints shall be spaced approximately 12 feet apart for length and width of areas covered with tile floor finish. Expansion joints shall be located wherever tile Work abuts restraining surfaces such as walls, curbs, columns and the like. Expansion joints shall also be located directly over any expansion joints and control joints in the structural floor slab.
- F. Base shall be as indicated and shall be installed by the Square method, Thin-lip method, or Flush method as indicated in the TCA Handbook for Ceramic Tile Installation. Method shall be as specified in the Detailed Specifications.

## GENERAL SPECIFICATION 09310 - CERAMIC TILE

---

### 3.03 PROTECTION

- A. All components of the Work shall be protected from detrimental weather and damage until construction operations are completed and acceptable to Engineer.
- B. Work which cannot for reasons acceptable to Engineer be covered with complete construction system before onset of weather detrimental to the Work shall be completely covered and protected in such a manner as to deflect water and weather from the installation without damaging adjacent Work.
- C. Ceramic tile work shall be protected from all damage and abuse from all other Contractors and installers involved in the Work until Final Acceptance by the City. All floor and wall surfaces shall be protected from abrasion or the adherence of any foreign material by maintaining covers when necessary. The wheeling of materials or placement of concentrated loads shall not be allowed on finished floors.

### 3.04 ADJUSTMENT

- A. System components which are dislodged, damaged, expanded, broken, penetrated or crushed by subsequent installation operations or damaged by detrimental weather shall be immediately replaced with undamaged material in compliance with the Sections and properly protected as specified.

### 3.05 CLEANING

- A. After installation, ceramic tile shall be cleaned and left in a neat condition. Units shall be cleaned using materials and processes as recommended by the manufacturer.

END OF SECTION

**GENERAL SPECIFICATION 09511 – SUSPENDED ACOUSTICAL  
CEILINGS**

---

**SECTION 09511  
Suspended Acoustical Ceilings**

**PART 1 GENERAL**

**1.01 SUMMARY**

- A. Suspended acoustical ceilings as specified herein shall include lay-in ceiling systems of acoustical ceiling panels, structural and exposed grid suspension systems, fire rated ceiling systems of acoustical fire rated panels and exposed grid suspension systems; metal panel ceiling systems of acoustical panels, spray-on acoustical treatment ceiling, spray-on fire rated ceiling, and all accessories and appurtenances.
- B. Acoustical ceilings shall be provided where shown on the Contract Drawings, specified in the Detailed Specifications, or as required for a complete installation.
- C. The Contractor shall implement practices and procedures to meet the project's sustainability goals as identified in the Contract Documents. The Contractor shall ensure that the sustainability requirements of this Section are implemented to the fullest extent.
- D. The following index of this Section is presented for convenience:

<u>Article</u>	<u>Title</u>	<u>Page</u>
09511-		
PART 1	GENERAL.....	1
1.01	Summary.....	1
1.02	Payment.....	2
1.03	Related Section.....	2
1.04	References.....	2
1.05	System Design Requirements.....	3
1.06	Quality Assurance.....	3
1.07	Submittals.....	3
1.08	Delivery, Storage And Handling.....	4
1.09	Spare Parts.....	5
PART 2	PRODUCTS.....	5
2.01	Manufacturers.....	5
2.02	Materials.....	5
PART 3	EXECUTION.....	8
3.01	Examination.....	8
3.02	Installation.....	8

**GENERAL SPECIFICATION 09511 – SUSPENDED ACOUSTICAL  
CEILINGS**

---

3.03	Protection .....	9
3.04	Adjustment.....	10
3.05	Cleaning .....	10
1.02	PAYMENT	
A.	No separate payment will be made for performing any work of this Section and all costs thereof shall be included in the lump sum price bid for the Contract, except as provided for in the Detailed Specifications.	
1.03	RELATED SECTION	
A.	General Specification 05081 - Galvanizing	
1.04	REFERENCES	
A.	NYCBC	- New York City Building Code
B.	ANSI/UL 263	- Fire-Resistance Rating of a Ceiling Assembly
C.	ASTM C423 - Standard Test Method for Sound Absorption and Sound Absorption Coefficients by the Reverberation Room Method	
D.	ASTM C635	- Standard Specification for the Manufacture Performance and testing of Metal Suspension Systems for Acoustical Tile and Lay-In Panel Ceilings
E.	ASTM C636	- Standard Specification Practice for Installation of Metal Ceiling Suspension Systems for Acoustical Tile and Lay-In Panels
F.	ASTM E84	- Standard Test Method for Surface Burning Characteristics of Building Materials
G.	ASTM E 119	- Standard Test Methods for Fire Tests of Building Construction and Materials
H.	ASTM E1264	- Standard Classification for Acoustical Ceiling Products
I.	NFPA 251 - Standard Methods of Tests of Fire Resistance of Building Construction and Materials	
J.	NFPA 286 - Standard Methods of Fire Tests for Evaluating Contribution of Wall and Ceiling Interior Finish to Room Fire Growth	

## GENERAL SPECIFICATION 09511 – SUSPENDED ACOUSTICAL CEILINGS

---

### 1.05 SYSTEM DESIGN REQUIREMENTS

- A. Suspended acoustical ceilings shall be complete systems and each shall include, acoustical ceiling panels, structural suspension system, exposed grid suspension system, trim, accessories and appurtenances as required for a complete installation.
- B. Spray-on acoustical treatment shall be a complete system and shall include, but not be limited to sprayed mineral fiber, sealer, trim, and appurtenances as required for a complete installation.
- C. Sustainable Design Requirements
  - 1. Recycled Content for Acoustical Panels: Postconsumer recycled content plus one-half of preconsumer recycled content not less than 35 percent.
  - 2. Recycled Content of Suspension Systems: Postconsumer recycled content plus one-half of preconsumer recycled content not less than 25 percent.

### 1.06 QUALITY ASSURANCE

- A. Requirements of Regulatory Agencies: All suspended ceiling work shall comply with fire-resistance ratings as shown, and as required by governing authorities and the New York City Building Code and shall be in accordance with the following requirements:
  - 1. Materials and equipment submitted for DEP's approval by the Contractor shall have met, at the time of their submittal, the certification and material acceptance requirements of the NYC Department of Buildings, unless otherwise required by the Authority Having Jurisdiction over the Work.
- B. Source Limitations: Obtain each type of acoustical ceiling panel and supporting suspension system from single source from single manufacturer.

### 1.07 SUBMITTALS

- A. Contractor shall submit Shop Drawings for approval of the Engineer. Submittals shall include, but not be limited to: catalog cuts, drawings, and reference materials.
- B. Submittals shall include the following:
  - 1. Data: The Contractor shall submit:
    - a. Copies of specifications, installation instructions and general recommendations from the acoustical ceiling product manufacturers, for each type of acoustical ceiling product.

## GENERAL SPECIFICATION 09511 – SUSPENDED ACOUSTICAL CEILINGS

---

- b. Manufacturer's data substantiating that the materials comply with the requirements shall be included.
    2. Samples:
      - a. Color and finish samples of each acoustical ceiling product, including each accessory and miscellaneous material to be used in the Work.
    3. Test Reports:
      - a. Test data shall be submitted for all fire rated ceiling systems.
    4. Sustainable Design Submittals:
      - a. Environmental Materials Reporting Form (EMRF) Recycled Content and Regional Materials. Provide the following information:
        - 1) Name of Product and Manufacturer.
        - 2) Material cost breakdowns. Cost breakdowns must include total material-only cost (excluding installation, labor and equipment).
        - 3) The percentage (by weight) of post-consumer and pre-consumer recycled content in the submitted product(s), if applicable.
        - 4) Indicate the location and distance from Project of material manufacturer and point of extraction, harvest, or recovery for each raw material. For assemblies, include the percentage by weight that is considered regional.
    5. VOC Reporting Form. Provide the following information:
      - a. For all adhesives and sealants used on site, provide the VOC content in grams/Liter (g/L) less water and other exempt compounds.
- 1.08 DELIVERY, STORAGE AND HANDLING
- A. Delivery of Materials:
    1. Materials shall not be delivered to the project site before the time of installation.
    2. Materials shall be delivered in sufficient quantities to allow continuity of the Work.
  - B. Storage of Materials:

## GENERAL SPECIFICATION 09511 – SUSPENDED ACOUSTICAL CEILINGS

---

1. Materials shall be stored in original, undamaged containers with manufacturer's labels and seals intact.
2. All materials shall be stored in a dry, enclosed area, off the ground and away from all possible contact with water, ice or snow.
3. Damage to materials during storage shall be prevented primarily by minimizing the amount of time they are stored at the job-site before being incorporated into construction systems.

### C. Handling of Materials:

1. Materials shall be handled in such a manner to avoid damage or breakage.
2. Materials shall not be exposed to detrimental conditions or physical damage. Materials, which are so exposed, shall be removed from the site and shall not be incorporated into the Work.
3. Materials shall be handled in such a manner so as to prevent inclusion of foreign matter.
4. Packages or containers shall not be opened until all necessary preparatory work is complete and installation is to begin immediately. Materials shall not be allowed to become wet or soiled or covered with ice or snow.

### 1.09 SPARE PARTS

- A. Two cartons of each type of acoustical panel supplied under these Sections shall be provided.

## PART 2 PRODUCTS

### 2.01 MANUFACTURERS

- A. Acoustical ceiling product manufacturers shall be as specified in the Detailed Specifications.

### 2.02 MATERIALS

- A. Acoustical panels shall be as follows:
  1. Mineral and Ceramic Acoustical Panels: Panels shall be lay-in panels with square cut edge of Class A noncombustible type per ASTM E1264 with flame spread 25 or under, and shall be U.L. labeled.
  2. Fire Rated Acoustical Panels: Panels shall be lay-in square cut edge panels approved for U.L. Design No.G258.

## GENERAL SPECIFICATION 09511 – SUSPENDED ACOUSTICAL CEILINGS

---

3. Light Fixture Fire Protection: Light fixtures in fire rated ceiling assemblies shall be protected using approved 1-1/2-inch thick light fixture protection fabricated to U.L. Design No. G258 requirements from flexible spun mineral fiber mats, unsurfaced and unbacked.
- B. Metal Panel Ceiling: Units complying with ASTM E 1264, shall be of aluminum and shall be finished with the manufacturer's standard baked enamel finish. A 1-inch layer of black low-density fiberglass acoustical insulation shall be installed on top of the panels. Suspension systems for acoustical panel ceiling systems, shall be as follows:
  1. General: Structural and exposed suspension systems shall include all supporting members and required trim. Exposed suspension systems shall have exposed surfaces of matching color and finish. Suspension systems shall comply with the requirements of ASTM C 635 and shall be as recommended by the manufacturer.
  2. Structural Suspension System: Structural system for suspended ceilings shall be rigidly mounted to the structure above and shall consist of 1-1/2-inch cold rolled galvanized steel 0.475 lb. channels clipped to 1/4-inch diameter galvanized steel rod hangers. Channels and rods shall be galvanized in accordance with General Specification 05081 - Galvanizing.
  3. Exposed Suspension System for Acoustical Ceramic Panels: Suspension system for lay-in acoustical ceramic panels shall be of aluminum with an aluminum cap, finished as specified in the Detailed Specifications.
  4. Exposed Suspension System for Acoustical Panels: Suspension system for acoustical panels shall be a grid suspension system for lay-in acoustical panels. Finish of the exposed portion of the grid shall be as specified in the Detailed Specifications.
  5. Exposed Suspension System for Fire Rated Acoustical Panels: Suspension system for fire rated lay-in ceilings shall be as approved for UL Design No. G258. Suspension system shall have exposed flanges capped with steel finished as specified in the Detailed Specifications.
  6. Suspension System for Metal Panel Ceiling Units: Suspension system for metal panel ceilings shall be the manufacturer's standard concealed aluminum runner system and trim. Access panels shall be of material and pattern to match the ceiling panels.



**GENERAL SPECIFICATION 09511 – SUSPENDED ACOUSTICAL  
CEILINGS**

---

- C. Anchors and Clips: Structural ceiling grid shall be hung from the structure using galvanized beam clips at steel beams, expansion shields at concrete slabs and slot tabs at metal floor or roof decks.
- D. Hangers and Support for Suspended Ceilings: Exposed ceiling suspension system shall be connected directly to the structural suspension system with galvanized direct hang clips. System shall include carrying channels, main runners, cross tees, clamps, angle moldings, clips, spacers, and trim.
- E. Tie wire, where required, shall be of 18 gauge stainless steel.
- F. Spray-on acoustical ceilings shall be of sprayed mineral fiber type and shall conform to Mineral-type fiber adhesive shall be as recommended by the manufacturer and as approved, and sealer shall be noncombustible-type as rated by U.L., Inc.
- G. Spray-On Fire Rated Ceiling: Spray-on treatment shall have a Fire Hazard Classification conforming to ASTM E84, listed by U.L., Inc., and as follows:
  - 1. Flame spread 5
  - 2. Fuel contribution 0
  - 3. Smoke development 0
- H. Acoustic nonwoven material shall be:
  - 1. Soundtex as manufactured by:
    - a. Freudenberg Performance Materials, Durham, NC.
    - b. Or approved equal, and shall meet the following requirements:
      - 1) Weight:  
61 g/m<sup>2</sup>
      - 2) Thickness:  
0.008 inch
      - 3) Fiber:  
Cellulose/Glass
      - 4) Flame and Smoke Spread:  
Class A (ASTM E84)
      - 5) Sound Impedence  
190 Ns/m<sup>2</sup>

## GENERAL SPECIFICATION 09511 – SUSPENDED ACOUSTICAL CEILINGS

---

### PART 3 EXECUTION

#### 3.01 EXAMINATION

- A. The Contractor shall verify that areas to receive acoustical ceiling systems are properly prepared and completed to final elevations.

#### 3.02 INSTALLATION

- A. Acoustical ceilings shall be installed in accordance with the manufacturer's recommendations.

- B. Lay-In Acoustical Tile Ceiling:

1. Structural system shall be installed with hanger rods and carrier channels at not more than 4'-6" on center in each direction, and in compliance with ASTM C636.
2. Exposed grid shall be installed in the pattern shown. Extra hangers shall be provided at lighting fixtures and air diffusers that are supported by the system. Hangers shall be spaced as required to prevent deflection in excess of 1/360 of the span of the cross-T or runner. Accessible tile board hold-down clips shall be installed.
3. All members shall be aligned for a true, level surface and straight lines.
4. Borders shall be finished with factory finished wall molding which shall be kept under tension by the use of wall springs. Parallel tile borders shall be 6 inches or larger and equal.
5. Fire-rated ceiling assemblies shall have a 2 hour U.L., Inc. fire protection rating. Fixture and duct protection boxes shall be installed as required for the specified fire protection rating.

- C. Metal Panel Acoustical Ceiling Treatment:

1. Metal panel ceiling and suspension system shall be installed in strict compliance with the manufacturer's recommendations and as approved. All members shall be aligned for true, level surface and straight lines. The installation shall provide for expansion and contraction of the ceiling system. Suspension system shall be direct hung from the structural suspension system as indicated.
2. Extra hangers shall be provided at lighting fixtures and air diffusers that are supported by the system. Hangers shall be spaced as required to prevent deflection in excess of 1/360 of the span of the cross-T or runner.

## GENERAL SPECIFICATION 09511 – SUSPENDED ACOUSTICAL CEILINGS

---

3. Lengths of panels shall be a minimum of 3-feet and a maximum of 16-feet. Join panels by butting on top of a matching colored interior splice. Joints shall be staggered on adjoining carriers. Acoustical pads shall be placed on panels between panel carriers.
4. Access panels shall be provided at all areas where access to space above the ceiling is necessary. Location of access panels shall be carefully coordinated with the locations of mechanical equipment requiring access.

### D. Spray-On Acoustical Ceiling Treatment:

1. Spray-on acoustical ceiling treatment shall be installed on clean surfaces, which are free of grease, dirt, oil, loose paint or other material. Surface preparation shall be in strict accordance with the manufacturer's instructions and recommendations.
2. Spray-on acoustical ceiling treatment shall be applied using an approved adhesive or a bonding medium. Fiber shall be sprayed onto the wet adhesive film to a thickness as required to achieve the specified noise reduction coefficient.
3. Spray-on acoustical treatment shall be applied in strict conformance with the manufacturer's directions by an applicator who is licensed by the manufacturer for this type of work.
4. Spray-on acoustical treatment shall be applied to concrete as shown. Cast bead moldings, 1-inch by 1-3/8-inch, shall be installed on ceilings and as shown and wherever the sprayed-on material abuts a vertical surface or terminates on a horizontal surface. Edges around the sprayed-on panels shall be finished evenly. Adjacent areas and materials shall be protected during the spraying operation. Casing beads shall be fastened using power driven anchors and as approved.
5. The manufacturer's standard transparent sealer shall be spray-applied to the finished acoustical ceiling. All adjacent areas shall be protected from the spray application of acoustical treatment and sealer.
6. The noise reduction coefficient of the system shall be as specified in the Detailed Specifications.

### 3.03 PROTECTION

- A. All components of the Work shall be protected from detrimental weather and damage until construction operations are completed.

**GENERAL SPECIFICATION 09511 – SUSPENDED ACOUSTICAL  
CEILINGS**

---

- B. Work, which cannot be covered with complete construction system before onset of weather detrimental to the Work, shall be completely covered and protected in such a manner as to deflect water and weather from the installation without damaging adjacent Work.
- C. Acoustical ceiling work shall be protected from all damage and abuse until Final Acceptance by the City.

3.04 ADJUSTMENT

- A. System components, which are dislodged, damaged, expanded, broken, penetrated or crushed after installation, shall be replaced immediately with undamaged material in compliance with the Sections, and properly protected as specified.

3.05 CLEANING

- A. General: Soiled or discolored surfaces shall be cleaned following installation. Acoustical units, which are damaged or improperly installed, shall be removed and replaced.
- B. Sprayed-on Insulation: Excess materials and debris and all over-sprayed insulation shall be removed from adjacent surfaces. Work areas shall be left in a clean condition.

END OF SECTION

**SECTION 09900  
Painting**

**PART 1 GENERAL**

**1.01 SECTION INCLUDES**

- A. Painting, as specified herein, shall include, but not be limited to, preparation of surfaces, shop painting of items furnished, field painting of structures, piping, conduit, ducts and equipment, and marking of piping and electrical conduit.
- B. Painting shall be provided as shown on the Contract Drawings, specified herein or in the Detailed Specifications, or as required for a complete installation.
- C. The following index of this Section is presented for convenience.

<u>Article</u>	<u>Title</u>	<u>Page</u>
		09900-
PART 1	GENERAL .....	1
1.01	Section Includes .....	1
1.02	Related Section .....	2
1.03	Payment.....	2
1.04	References.....	2
1.05	Submittals .....	2
1.06	Quality Assurance.....	4
1.07	Test Surfaces.....	5
1.08	Safety Requirements .....	5
1.09	Painting Requirements .....	6
1.10	Delivery, Storage And Handling.....	7
PART 2	PRODUCTS.....	7
2.01	Manufacturers .....	7
2.02	Environmental Requirements.....	8
2.03	Materials .....	9
PART 3	EXECUTION.....	12
3.01	Preparation .....	12
3.02	Installation.....	13
3.03	Cleaning And Repainting.....	18
3.04	Material Painting Schedule.....	18

## **GENERAL SPECIFICATION 09900 -- PAINTING**

---

### 1.02 RELATED SECTION

- A. General Specification 15076 - Piping and Equipment Identification.

### 1.03 PAYMENT

- A. No separate payment will be made for performing any work of this Section and the Contractor shall include all costs thereof in its lump sum price bid for the Contract, except as provided for in the Detailed Specifications.

### 1.04 REFERENCES

- A. Codes and standards referred to in this Section shall be as follows:
  - 1. SSPC - The Society of Protective Coatings (formerly of Steel Structures Painting Council)
    - a. SSPC-SP 1 Solvent cleaning
    - b. SSPC-SP 6 Commercial blast cleaning
    - c. SSPC-SP 10 Near white cleaning
    - d. SSPC-SP 2 Hand tool cleaning
    - e. SSPC-SP 11 Power tool cleaning to bare metal
    - f. SSPC- SP 15 Commercial grade power tool cleaning
    - g. SSPC-SP 16 Brush off Blast Cleaning of Non Ferrous Metals
  - 2. ASTM - American Society for Testing Materials
    - a. ASTM D3359 - Measuring Adhesion by Tape Test
    - b. ASTM D16- Terminology Relating to Paint, Varnish, Lacquer, and related Products.
  - 3. NSF- National Sanitation Foundation

### 1.05 SUBMITTALS

- A. Contractor shall submit Shop Drawings for approval of the Engineer. Submittals shall include, but not be limited to: catalog cuts and reference materials.
  - 1. Color Chart: The Contractor shall submit the manufacturer's standard color chart for color selection for painting of items other than process piping, valves, pipe line equipment, pump casings, blowers and other mechanical equipment and their drive units, all of which shall be in conformance with the "BACKGROUND COLOR" of the General Color Code

## GENERAL SPECIFICATION 09900 -- PAINTING

---

specified in General Specification 15076 - Piping and Equipment Identification.

2. Paint Samples: The Contractor shall submit:
  - a. Two one-quart samples of each required kind of paint material, or the ingredients thereof which are to be mixed on the job.
  - b. Samples shall be labeled as required under Article 1.07, and shall include the certificate of the manufacturer stating the actual percentages by weight and volume of all ingredients entering into the mixture.
  - c. Upon request, further samples shall be provided as the work progresses.
  - d. Painting materials shall not be applied without written approval of samples by the Engineer.
3. Painted Surface Samples:
  - a. Upon request, duplicate samples of the results obtained by painting and finishing various materials on the work shall be submitted. Such samples, and the approved paint applied thereto, shall be applied in strict conformance with these Sections.
  - b. Finished areas shall be considered adequate for the purpose of determining the quality of the work. All painting work shall be performed in a quality equal to the approved samples.
  - c. Where equipment is customarily shipped with a standard finish, samples of the proposed color and finish shall be submitted for approval prior to shipping.
4. Certification: The Contractor shall furnish:
  - a. Affidavits from the manufacturer certifying that materials furnished conform to the requirements specified
  - b. And that paint products have been checked for compatibility.
5. Immersion Certification: The Contractor shall furnish:
  - a. Affidavits from the manufacturer certifying that coatings in immersion service contain no water soluble solvents or corrosion inhibitive (active) pigments with slight water solubility.

## GENERAL SPECIFICATION 09900 -- PAINTING

---

6. List of Paints: The Contractor shall submit:
  - a. A list of paint products with mil thickness and solids by volume, including all paint applied in the shop and in the field. The list shall be in accordance with the requirements of this Section and the recommendations of the paint manufacturer.
7. Applicator's Quality assurance:
  - a. Submit list of a minimum of 5 completed projects of similar size and complexity to this work. Include for each project:
    - 1) Project name and location
    - 2) Name of owner
    - 3) Name of contractor
    - 4) Name of engineer
    - 5) Name of coating manufacturer
    - 6) Approximate area of coatings applied.
    - 7) Date of completion.
8. Warranty:
  - a. Submit manufacturer's standard warranty.

### 1.06 QUALITY ASSURANCE

- A. Paint Quality Assurance Records: The following information shall be recorded for every paint project and submitted to the construction Project Manager/ Project Manager:
  1. Date
  2. Shift
  3. Part Temperature
  4. Dew Point
  5. Paint Batch Number/s
  6. Mixing Time for Each Part and the Combined Parts of a Paint System
  7. Pot Life
  8. Curing Time of Primer and Finish Layers
  9. Paint thickness measurements (DFT)



## GENERAL SPECIFICATION 09900 -- PAINTING

---

10. Holiday Test Results and Repair Data
11. Peel Test Results and Repair Data
12. Foreman or Supervisor's Signature

### 1.07 TEST SURFACES

- A. The Contractor shall paint certain areas of concrete and other surfaces, where directed, using approved coatings for use by the Engineer for comparisons with coating systems applied during the progress of the work.
  1. Such coated areas shall not be subsequently painted during the entire period of construction or during the period one-year after the date of final acceptance.
  2. At or about one year after final acceptance the test surfaces shall be inspected by the City for any deterioration such as cracks, blisters, flakes and excessive chalking.
  3. The Contractor shall supply all material and labor and shall perform any remedial work on all such deteriorated surfaces using the coating system represented by the test surface at no additional cost to the City.

### 1.08 SAFETY REQUIREMENTS

- A. All painting materials specified herein, and ingredients of coatings containing substances that are potentially toxic or hazardous shall be shipped with warning labels. These products shall be applied in strict conformance with the safety requirements of the following:
  1. The Manufacturer
  2. The National Paint and Coatings Association (NPCA)
  3. The Society of the Plastics Industry (SPI)
  4. The Manufacturing Chemist Association (MCA)
  5. The Society of Protective Coatings formerly of Steel Structures Painting Council (SSPC)
  6. The United States Government Occupational Safety and Health Administration (OSHA)
  7. The Health and Safety Requirements of the State of New York (PESH- Public Employees Safety and Health)
  8. The Health and Safety Requirements of the City of New York (COSH- Citywide Office of Safety and Health)

## GENERAL SPECIFICATION 09900 -- PAINTING

---

### 1.09 PAINTING REQUIREMENTS

- A. General: The Detailed Specifications do not specify the surface treatment for every individual part of the work, however this Contract shall be provided with a complete painting job throughout the work as specified herein. All items customarily or specified to be shop painted shall be primed and finished in the shop. Field painting will not be allowed unless requested in writing to the Engineer, and written consent is given by the Engineer. In general, only areas that are to be field welded are not to be painted until field erected.
- B. Manufacturer's Standard Finished Items: The following items shall be furnished with the manufacturer's standard prime and finish coats applied in the shop: pumps, motors, gears, gear housings, air compressors, wall fans, temperature control and instrument panels, process air blowers, engines, filters, strainers, air dryers, meters, gas boosters, gas turbines, generators, panelboards, transformers, boilers, condensing units, water chillers, cooling towers, condensers, heat exchangers, humidifiers, air handling units, sound attenuators, air conditioning and dehumidification units, convector cabinets, unit heaters, enclosures for finned tube radiators, cabinet heaters, boilers, wood seats, lockers, metal toilet partitions, metal urinal screens, aluminum fascia, motor control centers, aluminum light standards, and hoisting equipment. Steel reinforcing bars for concrete shall be coated in accordance with the Detailed Specifications. When powder coatings are required by the Detailed Specifications, the powder coatings shall be in accordance with the requirements of the manufacturer of the item.
- C. Painted Items: The following items shall be painted as specified herein: steel water storage tank, structural steel and wrought metals, composite metal floor deck, pipelines, hangers and supports, sluice gates, pumps and pumps parts, valves, valve and sluice gate operators and stands, guard housings, air filter equipment, effluent strainers, heat exchangers, air receivers, tanks, air silencing equipment, storage tanks, gas domes, sediment tanks, steel stair framing, steel lintels, hollow metal doors and frames, gypsum wallboard, interior concrete block, interior concrete walls, columns, beams and ceilings, covering over insulation on piping, electrical conduit systems, small piping and copper tubing, ducts, covering over ducts, and PVC piping, valves and fittings.
- D. Unpainted Items: The following items shall not be painted, unless otherwise specified: registers, grilles, dampers and linkage, fire sprinklers, name and identification plates and tags, floor gratings, brass pipe and fittings, brass valves, stainless steel, wood, stop log panels, spray-on fireproofing steel to receive spray-on fireproofing, surfaces to

receive field welding, and fraying surfaces of high strength bolted connections.

1.10 DELIVERY, STORAGE AND HANDLING

- A. General: All products and materials shall be delivered, stored, and handled as specified in Contract Documents and as follows:
- B. Delivery and Storage: All paint materials delivered and stored at the site shall be from the approved manufacturer only.
- C. Packaging and Labeling: Paints, stains, varnish or ingredients of paints to be used on the job shall be properly prepared, packed, and labeled. All materials shall be delivered to the site in original, unbroken containers bearing the manufacturer's printed labels, which shall specify the following:
  - 1. Project and Contract No.
  - 2. Name of Manufacturer
  - 3. Address of Manufacturer
  - 4. Generic Name of Paint or Ingredients
  - 5. Brand and Trade Mark
  - 6. Schedule Letter as Listed Herein
  - 7. Percent Solids by Volume
  - 8. Net Quantity
  - 9. Date of Manufacturer
  - 10. Date Packed
- D. Storage: Painting materials shall be stored at the site in manner and place which shall be in accordance with applicable codes and regulations, and in accordance with manufacturer's instructions. The storage space shall be kept clean at all times. Every precaution shall be exercised to eliminate fire hazards.

PART 2 PRODUCTS

2.01 MANUFACTURERS

- A. Standards of Quality: Proprietary protective coatings included herein by brand name or trade mark are given solely as standards of quality and for bidding purposes and do not preclude the use of an approved equivalent.

## GENERAL SPECIFICATION 09900 -- PAINTING

---

- B. Latest Products: Unless specified otherwise, the proprietary protective coatings of the manufacturer's latest products in regular production on the date of receipt of order shall be provided.
- C. Equivalent: Equivalent products shall be of a standard, regularly produced product of a manufacturer. Equivalent products shall be submitted on their applicable published printed literature that states the generic type, instructions for use, solids by volume, application rates, and chemical components of vehicles and solids. Equivalent products shall be accompanied by a list of projects where each of the coatings has been used on new construction and has rendered satisfactory service for at least three years. Should the manufacturer's literature of the product being offered call for higher film thickness, the greater film thickness shall be applied, and the submitted schedule shall so state.
  - 1. Paintings approved as manufactured by these Painting Manufacturers:
    - a. Tnemec Company, Inc., Kansas City, MO.
    - b. Sherwin Williams, Cleveland, OH.
    - c. International Paint, Houston, TX.
    - d. Carboline Company, St. Louis, MO.
    - e. PPG Amercoat, Little Rock, AR.
    - f. Or approved equal

### 2.02 ENVIRONMENTAL REQUIREMENTS

- A. Weather:
  - 1. Air and surface Temperatures: Prepare surfaces and apply and cure coatings within air and surface temperature range in accordance with manufacturer's instructions.
  - 2. Surface Temperature: Minimum of 5 degrees F (3 degrees C) above dew point.
  - 3. Relative Humidity: Prepare surfaces and apply and cure coatings within relative humidity range in accordance with manufacturer's instructions.
  - 4. Precipitation: Do not prepare surfaces or apply coatings in rain, snow, fog or mist.
  - 5. Wind: Do not spray coatings if wind velocity is above manufacturer's limit.
- B. Ventilation: Provide ventilation during coating evaporation stage in confined or enclosed areas in accordance with AWWA D102.

**GENERAL SPECIFICATION 09900 -- PAINTING**

---

C. Dust and Contaminants:

1. Schedule coating work to avoid excessive dust and airborne contaminants.
2. Protect work areas from excessive dust and airborne contaminants during coating application and curing.

2.03 MATERIALS

A. General:

1. Compatible shop and field coats shall be provided.
2. All coats of paint for any particular surface shall be from the same manufacturer.
3. Paint shall be of approved color as selected from the manufacturer's standard range of colors.
4. The Contractor shall submit proposed modifications to the specified painting systems for the Engineer's approval prior to use.
5. Paints containing lead or manganese driers shall not be submitted.

B. Classification of Paints: Alphabetical designations have been used in the following list to classify/group acceptable paints by the type and quality of materials desired. Equivalent material from the manufacturers named above or from other approved manufacturers may be used in any of these paint groups in accordance with the procedures for substitution.

<b>CLASSIFICATION OF PAINTS</b>			
<b>Paint Group</b>	<b>Product Name and Number</b>	<b>Volume Solids %</b>	<b>Dry Film Thickness Mils per Coat</b>
<b>A</b>	<b>Tnemec:</b> Series V69 Hi-Build Epoxoline II	69	3.0-5.0
	<b>Carboline:</b> Carboguard 60/61 or Carboguard 635	72 65	3.0-6.0 3.0-6.0
	<b>Sherwin Williams:</b> Copoxy Shop Coat Primer	72	2.0-4.0
	<b>International Paint:</b> Integrated 345 or Devran 224HS	82	3.0-4.0
	<b>PPG:</b> Amercoat 370	66	4.0-6.0
<b>B</b>	<b>Tnemec:</b> Series V140-44 BR Pota-Pox Plus	69	4.0-6.0
	<b>Carboline:</b> Sanitile 120	38	1.0-2.0

**GENERAL SPECIFICATION 09900 -- PAINTING**

<b>CLASSIFICATION OF PAINTS</b>			
<b>Paint Group</b>	<b>Product Name and Number</b>	<b>Volume Solids %</b>	<b>Dry Film Thickness Mils per Coat</b>
	<b>Sherwin Williams:</b> Dura-Plate 235 (Waste Water)	72	3.0-5.0
	<b>International Paint:</b> Interseal 670 HS or Bar Rust 233HS	82	3.0-6.0
	<b>PPG:</b> Amerlock 2/400	85	4.0-6.0
<b>C</b>	<b>Tnemec:</b> Series 73 Endura-Shield	68	2.0-3.0
	<b>Carboline:</b> Carbothane 134 HG Carbothane 134WB	70 50	2.0-3.0 2.0-3.0
	<b>Sherwin Williams:</b> Acrolon-218HS Hi solid Polyurethane	65 65	3.0-5.0 2.0-3.0
	<b>International Paint:</b> Interthane 990HS or Devathane 379 UVA	68	2.0-3.0
	<b>PPG:</b> Amercoat 450H	67	2.0-4.0
<b>D</b>	<b>Tnemec:</b> Series 69 Hi-Build Epoxoline II	69	3.0-5.0
	<b>Carboline:</b> Carboguard 61/691 Carboguard 635	80-100 65	4.0-8.0 4.0-8.0
	<b>Sherwin Williams:</b> Macropoxy 646	72	4.0-6.0
	<b>International Paint:</b> Interseal 670HS or Bar Rust 233H/236	82	3.0-6.0
	<b>PPG:</b> Amercoat 240	87	4.0-12.0
<b>E</b>	<b>Tnemec:</b> Series 90-97 Tnemec-Zinc	63	2.5-3.5
	<b>Carboline:</b> Carbozinc 859 or Carbozinc 859 VOC or Carboguard 60	66	3.5-5.0
	<b>Sherwin Williams:</b> Corothane I Galvapac	67	2.5-3.5
	<b>International Paint:</b> Interzinc 52 or Catha Coat 302H or Catha 316 (immersion)	59	3.0-5.0
	<b>PPG:</b> Novaguard 840	100	16.0-24.0
<b>F</b>	<b>Tnemec:</b> Series 130 Envirofill Masonry Filler	68	As Required
	<b>Carboline:</b> Sanitile 100 Block Filler	54	As Required
	<b>Sherwin Williams:</b> Heavy Duty Block Filler (dry) Kem Cati –Coat Epoxy Filler/ Sealer	80 72	As Required As Required
	<b>International Paint:</b> Truglaze 4015 or Intercryl 320	45	As Required
	<b>PPG:</b> Amerlock 400 BF	75	10.0-20.0

**GENERAL SPECIFICATION 09900 -- PAINTING**

<b>CLASSIFICATION OF PAINTS</b>			
<b>Paint Group</b>	<b>Product Name and Number</b>	<b>Volume Solids %</b>	<b>Dry Film Thickness Mils per Coat</b>
<b>G</b>	<b>Tnemec:</b> Series 151 Elasto-Grip	17	1.0-1.5
	<b>Carboline:</b> Galoseal WB	31	0.5-1.0
	<b>Sherwin Williams:</b> Pro-Mar 200 Primer	28	1.0-2.0
	<b>International Paint:</b> Glidden PC 1000	39	1.0-2.0
	<b>PPG:</b> Speedhide Interior Primer 6-2	28	1.0
<b>H</b>	<b>Tnemec:</b> Series 6	43	2.0-3.0
	<b>Carboline:</b> Sanitile 155	38	2.0-3.0
	<b>Sherwin Williams:</b> Promar 200 Series (dry wall) DTM Acrylic (pipe insulation)	41	1.5-2.0
	<b>International Paint:</b> Glidden Dulux Lifemaster 1500 series	45	1.5-2.0
	<b>PPG:</b> Speedhide Interior Latex 6-411	37	1.5
<b>I</b>	<b>Tnemec:</b> Series 140-AA83 Pota-Pox Plus	82	4.0-6.0
	<b>Carboline:</b> Carboguard 691/ Phenoline 341	80-100	4.0-6.0
	<b>Sherwin Williams:</b> Macropoxy 646 PW	72-98	4.0-6.0 Upto 50 Mils
	<b>International Paint:</b> Interseal 670HS or Bar Rust 233HS	82	4.0-6.0
<b>J</b>	<b>Carboline:</b> Phenoline 311	47	1.0-3.0
	<b>Sherwin Williams:</b> Duraplate 235	72	3.0-5.0
	<b>International Paint:</b> Enviroline 54	70	3.0-5.0
<b>K</b>	<b>Carboline:</b> Reactamine 760 Plasite 4550S	100 100	20.0-100.0 20.0-60.0
	<b>Sherwin Williams:</b> Sherflex or C / Cote SC	100	25.0-100.0/ 20.0-60.0
	<b>International Paint:</b> Enviroline 222	100	20.0-100.0
<b>L</b>	<b>Tnemec:</b> Series 141	82	6.0-14.0
	<b>Carboline:</b> Reactamine 28 or Carboguard 1340 WB	100	1.0-2.0
	<b>Sherwin Williams:</b> Tank Clad HS	80	5.0-8.0
	<b>International Paint:</b> Ceilcote Interzone 954	85	14.0-18.0
<b>M</b>	<b>Tnemec:</b> Series 431 Perma- Shield PL	100	30.0-40.0
	<b>Carboline:</b> Reactamine ET	100	30.0-40.0

**GENERAL SPECIFICATION 09900 -- PAINTING**

<b>CLASSIFICATION OF PAINTS</b>			
<b>Paint Group</b>	<b>Product Name and Number</b>	<b>Volume Solids %</b>	<b>Dry Film Thickness Mils per Coat</b>
	<b>Sherwin Williams:</b> Dura Plate UHS or Cor Cote SC	100	30.0-40.0
N	<b>Tnemec:</b> Series FC22 or 22 Epoxoline	100	20.0-30.0
	<b>Carbolite:</b> 341	100	20.0-30.0
	<b>Sherwin Williams:</b> Sher Plate PW	100	25.0-30.0
	<b>International Paint:</b> Interline 975	80	30.0-40.0

**PART 3 EXECUTION**

**3.01 PREPARATION**

- A. Surface Preparation: Prior to painting, Surface preparation prior to painting shall be in accordance with the following guidelines and as recommended by the painting material manufacturer.

<b>SURFACE PREPARATION GUIDELINES</b>	
<b>Class of Work</b>	<b>Preparation of Surface Prior to Painting</b>
Structural Steel and Steel Encased in Concrete, Masonry or Fireproofing	All visible oil, grease, dirt, dust, mill scale, rust, paint, oxides, corrosion products and other foreign matter shall be removed by compressed air nozzle blasting, centrifugal wheels or other specified method. Discoloration caused by certain stains shall be limited to no more than 33 percent of each square inch of surface area in accordance with Society of Protective Coatings (SSPC-SP6).
Steel (other than structural, encased or galvanized) and Steel Submerged Under Water	All visible oil, grease, dirt, dust, mill scale, rust, paint, oxides, corrosion products and other foreign matter shall be removed by compressed air nozzle blasting, centrifugal wheels or other specified method. Discoloration caused by certain stains shall be limited to no more than 5 percent of each square inch of surface area in accordance with Society of Protective Coatings (SSPC-SP10).



**GENERAL SPECIFICATION 09900 -- PAINTING**

<b>SURFACE PREPARATION GUIDELINES</b>	
Class of Work	Preparation of Surface Prior to Painting
Galvanized Steel and Other Metals	All welds, beads, blisters or protuberances, other than identification markings shall be smooth, and other imperfections shall be removed. All nonferrous metals and galvanized steel, whether shop primed or field primed, shall be solvent cleaned in accordance with Society of Protective Coatings (SSPC-SP1).
Canvas Pipe Covering	All adhering debris shall be removed and indentations or other unsightly spots shall be smoothed out to give a uniform, even surface. Surfaces shall be brushed clean.
Gypsum Wallboard and Plastered Surfaces	Gypsum wallboard shall be prepared as recommended by the wallboard manufacturer.  Plaster surfaces shall be dry. Scratches, cracks, holes and other defects shall be filled flush with adjoining surfaces by approved methods, sandpapered smooth, and brushed clean.
Concrete and Masonry Surfaces	Concrete and masonry shall be dried for a minimum of 28 days and then the dry concrete and masonry shall be brushed and washed to remove all loose dirt, dust, free lime and other deleterious substances by approved methods. Protruding fins and other adhering matter shall be removed or ground until a smooth, even finish is obtained. Concrete surfaces to be painted shall be acid etched or otherwise roughened as recommended by the manufacturer of the coating to be applied, to produce a slightly granular surface required for adherence of coating to the concrete, unless otherwise indicated.
PVC	All adhering debris shall be removed and surface shall be roughened using suitable sandpaper. Surfaces shall be dry and free from dirt, oil, grease etc.

**3.02 INSTALLATION**

- A. General: All painting and coatings shall be applied in accordance with the manufacturer's recommendations and approved submittals. A representative of the paint manufacturer shall inspect the surfaces to be painted and shall advise on the proper application. The paint manufacturer representative shall periodically be consulted regarding ambient temperature and humidity conditions.

## GENERAL SPECIFICATION 09900 -- PAINTING

---

- B. Shop Painting: The following items shall be provided with shop coats of primer and finish coats as herein specified before exposure to the weather:
1. Metals:
    - a. Structural steel  
Note: Consider using hot dip galvanizing at crevices or hard to reach places on steel structural.
    - b. Miscellaneous steel and wrought iron
    - c. Ornamental wrought and light iron
    - d. Iron castings
  2. Machinery and Equipment:
    - a. Mechanical and electrical equipment
  3. Pipe:
    - a. All piping except galvanized iron, stainless steel, aluminum, copper, brass and bronze piping.
- C. Field Painting: All painting at the site of the project is hereby designated as field painting for those items that cannot be shop painted or are touched up due to minor damage to the painted surface.
1. Repair and Repainting: Field coatings shall not be applied until all marred surfaces have been repaired or repainted. Shop coated surfaces shall be thoroughly cleaned and retouched prior to the application of successive paint coats in the field.
  2. Unpainted Materials: Do not paint or finish copper, bronze, chromium plate, nickel, stainless steel, aluminum (except ducts and conduit adjacent to finish painted surfaces), monel metal, lead, lead coated copper and brass, except as otherwise indicated.
  3. Items to Receive Coating: All ferrous metals and insulated surfaces shall be provided with a protective coating. Interior surfaces, exposed masonry walls and concrete walls, floors and ceilings shall be provided with protective coatings as indicated on the drawings and specified.
  4. Surface Condition: Only surfaces that are dry and free from dust, grease or other undesirable or interfering substances shall receive coatings. Coatings shall be as specified herein in the "Material Painting Schedule".

## GENERAL SPECIFICATION 09900 -- PAINTING

---

5. Application: Finish coats shall be applied after all adjacent work has been completed. Successive coats shall have different shades or tints of color wherever possible. Colors shall be as selected and approved by the Engineer. Prime and successive finish coats shall be cleaned, sand papered, or otherwise treated before the next coat is applied, in accordance with the recommendations of the coating manufacturer, and as approved by the Engineer. All coats shall be inspected and approved by the Engineer, before application of any succeeding coats. All coats shall be applied to the dry film thickness (DFT) specified. Coatings shall be applied by skilled personnel under adequate illumination. All painted surfaces shall be left in a clean, orderly and acceptable condition.
  6. Surface and Atmospheric Conditions: Paints shall not be applied when the surface temperature is less than 40 degrees F, when the relative humidity exceeds 85 percent, or when the surface to be painted is wet or damp, unless more stringent requirements are called for by the paint manufacturer.
- D. Field Painting Operations: Surfaces to be given protective coating shall be thoroughly cleaned. Scratches and abrasions on equipment which has been shop coated shall be refinished and all surfaces to be field painted shall be approved by the Engineer before proceeding with painting. Painting shall be performed in a continuous and orderly operation to facilitate adequate inspection, however material subject to weathering or corrosion shall be given prime coats as quickly as practicable.
1. Method of Application: All paint material shall be applied by brush or roller. Spray painting will be permitted only with the specific approval of the Engineer. Surfaces which are so close together as to prevent the insertion of a standard size roller or brush shall be painted thoroughly with the prescribed number of coats by using special narrow rollers or brushes.
  2. Adjacent Areas: Areas under and adjacent to painted surfaces shall be fully protected at all times. Dripped or spattered paint shall be promptly removed and any adjacent surfaces that have been damaged or discolored by overspray shall be repaired, refinished, and repainted.
  3. Tinting: Successive coats of paint shall be tinted to make the various coats easily distinguishable. Undercoats of paint shall be tinted to the approximate shade of the final coat of paint. Final coats of paint shall not be applied until all other work has been completed, the dirt and rubbish removed and the surfaces

## GENERAL SPECIFICATION 09900 -- PAINTING

---

- suitably prepared. Paint to be applied shall be at room temperature.
4. Conditions for Application: Each coat of paint shall be given sufficient time to cure per the manufacturer's recommendation before application of the succeeding coat. Each succeeding coat shall be applied within the recoat time specified by the manufacturer; otherwise the painted surface shall be prepared per the manufacturer's recommendation before it is recoated. Exterior painting will not be allowed in dust laden air, during damp or threatening weather, or on moist or wet surfaces, or when the surface temperature is below 40 degrees F on a falling thermometer or under 50 degrees for catalyzed epoxy material; it will not be allowed in extreme heat or when metal is hot enough to cause the paint to blister and produce a porous film. Do not apply interior painting until the building is thoroughly dry. If the temperature in the interior of the building, in the opinion of the Engineer, is too low painting will be stopped until the building is heated. Proper ventilation and sufficient heat shall be maintained to permit the paint to dry. The building shall be maintained to be free from dust.
  5. Remedial Work: Any paint found defective shall be removed. Touch-up and remedial painting shall be provided as directed and as required until completion and acceptance of final work. If damage to the painted surface is excessive, as determined by the Engineer, that item shall be rejected and shipped back, at Contractor's expense, to be properly recoated before it can be accepted.
  6. Application: Each coat of paint shall be applied as a continuous film of uniform thickness, free of pinholes and blemishes, to the maximum extent practicable. Any thin spots or areas missed in the application shall be repainted and permitted to dry before the next coat is applied. An approved low voltage wet sponge "holiday" detector shall be used as directed by the Engineer. All paint shall be carefully applied to a smooth even coating without runs or sagging. Enamels shall be brushed with a smooth even flow. Each coat of paint shall be dry, not only on the surface, but throughout the thickness of the paint film, before the next coat is applied. Finished surfaces shall be uniform in gloss, finish, and color, and free from flash spots and brush marks. In all cases, the resultant paint film produced shall be satisfactory in all respects to the Engineer.

## GENERAL SPECIFICATION 09900 -- PAINTING

---

7. Thinning: If the paint material must be diluted for application by spray gun, the coating shall be built up to the same film thickness achieved with undiluted material (i.e., one gallon of paint as originally furnished must not cover a greater surface area when sprayed than when applied unthinned by brush). Where thinning is necessary, only the products of the manufacturer furnishing the paint shall be used for the particular purpose, and thinning shall be done with the manufacturer's knowledge, in accordance with his printed instructions.
  8. Thickness and Adhesion Testing: Dry film thickness of each coat shall be as specified herein. Dry film thickness will be checked by the Engineer or a representative with a magnetic gauge for ferrous metal in accordance with SSPC 2 or Tooke gauge destructive test for concrete. Film thickness of shop coats or other previously applied coating shall be checked by the Engineer or a representative and recorded before painting in order to determine thickness of field coats. Dry film thicknesses for concrete surfaces shall be determined by measuring with a wet-film gauge and by material consumption. Paint adhesion shall be tested by the peel method in accordance with ASTM D 3359.
  9. Inaccessible Items: Exposed members which will be inaccessible after erection shall be painted and cleaned prior to erection.
  10. Coverage: All surfaces to be painted shall be completely covered. When color on undercoats shows through the final coat of paint, surfaces shall be covered by additional coats until paint is of uniform color and appearance and coverage is complete.
  11. Safe Atmosphere: The Contractor shall provide sufficient temporary ventilation during painting operations in enclosed areas to remove moisture and solvents, and to keep the atmosphere safe from harmful or dangerous fumes and dust levels for personnel.
- E. Workmanship: Only skilled painters shall perform the work and specialists shall be employed where required. Finished surface shall not show brush marks or other irregularities. Top and bottom edges of doors shall be painted as required for the adjacent surfaces. Undercoats on hollow metal shall be thoroughly and uniformly sanded with No. 00 sandpaper, or equal abrasive, to remove all surface defects and provide a smooth, even surface.

---

## GENERAL SPECIFICATION 09900 -- PAINTING

---

- F. Mixing: All paints and coatings shall be mixed in accordance with the manufacturer's instructions on the printed label. The Contractor shall provide galvanized iron pans of sufficient size to contain all mixing pails and mix all paints and ingredients therein.
- G. Rates of Application: Paints shall be applied so as to give coverage per gallon not greater than that recommended by the manufacturer. Quantities of paint used for successive coats on the various parts of the work shall be recorded in a manner satisfactory to the Engineer.
- H. Touch-Up of Shop-Primed and Finished Items: Touch-up of any and all damaged portions and imperfections in shop-primed and finished items shall be accomplished using the same paint as used for the shop prime and finish. Surface shall be prepared prior to touch-up by wire brushing and sanding to remove rust, scale and loose paint.
- I. Aluminum and Incompatible Surfaces: Where aluminum surfaces come in contact with incompatible metals, lime, mortar, concrete or other masonry materials, one field coat of Group A paint as specified under Article 2.03 "Classification of Paints" in this Section shall be applied to the incompatible surfaces.
- J. Concealed Surfaces: All wall surfaces which will be concealed by equipment shall be painted before equipment installation.

### 3.03 CLEANING AND REPAINTING

- A. The Contractor shall touch up and restore any finish damaged. Paint or other finishes spilled, splashed or splattered shall be removed from all surfaces using care so as not to mar any surface or item being cleaned.
  - 1. The Contractor shall rectify any failures or breakdowns, loosening of the paint or coatings within a year after acceptance of work, regardless of the paint systems used. This will require removal of the entire coating where failure occurs and repainting with the coating system previously specified. Patching will not be allowed.

### 3.04 MATERIAL PAINTING SCHEDULE

- A. All materials shall be painted in accordance with the following schedule. The number of coats shall not be less than the number shown on the schedule.

---

TEXT CONTINUES IN THE FOLLOWING PAGES

---

**GENERAL SPECIFICATION 09900 -- PAINTING**

<b>MATERIAL PAINTING SCHEDULE</b>																				
<b>Materials and Conditions</b>	<b>Paint Groups (A-N)</b>																			
	Tn: Tnemec, Cb: Carboline, SW: Sherwin Williams, IP: International paint, PPG: PPG/Amercoat																			
	<b>Prime Coat</b>					<b>Finish Coats</b>														
						<b>1<sup>st</sup></b>					<b>2<sup>nd</sup></b>					<b>3<sup>rd</sup></b>				
<b>Paint Manufacturer</b>	Tn	Cb	SW	IP	PPG	Tn	Cb	SW	IP	PPG	Tn	Cb	SW	IP	PPG	Tn	Cb	SW	IP	PPG
<b>Steel and Iron</b> - Structural and Miscellaneous Uses:																				
Interior (Indoors) shop primed, field finished	B	A	A or D	A	A	B	A	D	A	B	A	A	D	A	B	A	A	D	A	--
Exterior (Outdoors) shop primed, field finished	B	A	A or D	B or A	A	B	A	A or D	B or A	B	A	A	D	A	B	C	C	C	C	--
Submerged, Buried or Continuously Wet Exposed to sewage, shop primed, field finished	B	A	A	B	A	B	A	A or B	B	B	D	D	B	D	D	D	D	B	D	--
<b>Steel and Iron</b> - Industrial Equipment (Exposed to wastewater):																				
Submerged, Buried or <b>continuously wet in wastewater</b> , completely shop coated inside and out, includes OEM factory finished items such as gates, valves, etc.	L Or M*	A Or K*	A or M*	D or L or K	B	L	A	B Or L	D	B	L	A	B Or L	D	B	--	--	B	D	--
Above grade, indoors, <b>exposed to waste water</b> , completely shop coated inside and out, includes OEM factory finished, items such as gates, valves etc.	L or M*	A	A or M*	D or L or K	A	L	A	B Or L	A or D	B	L	C	B Or L	A or D	B	--	--	B	A or D	--

**GENERAL SPECIFICATION 09900 -- PAINTING**

<b>MATERIAL PAINTING SCHEDULE</b>																				
<b>Materials and Conditions</b>	<b>Paint Groups (A-N)</b>																			
	<b>Tn: Tnemec, Cb: Carboline, SW: Sherwin Williams, IP: International paint, PPG: PPG/Amercoat</b>																			
	<b>Prime Coat</b>					<b>Finish Coats</b>														
						<b>1<sup>st</sup></b>					<b>2<sup>nd</sup></b>					<b>3<sup>rd</sup></b>				
<b>Paint Manufacturer</b>	Tn	Cb	SW	IP	PPG	Tn	Cb	SW	IP	PPG	Tn	Cb	SW	IP	PPG	Tn	Cb	SW	IP	PPG
Above grade, outdoors, <b>exposed to waste water</b> , completely shop coated inside and out, includes OEM factory finished, items such as gates, valves etc.	L or M*	A	A Or M*	D or L or K	A	L	A	B Or L	A or D	B	L	C	C	A or D	B	--	--	B	A or D	--
Inside of item immersed in sewage	L or M*	A or J	A Or M*	D or L or K	D Or E*	L	A or J	B or L	D	D or E	L	A or K	B or L	D	D or E	--	--	B	D	--
Ductile Iron or Steel Process Piping, submerged, Buried or constantly wet, <b>exposed to sewage</b> , H2S exposures, OEM factory finished.	M*	A or M*	A Or M*	D or K	E*	--	A	B	D or K	--	--	A	B	D or K	--	--	--	B	D or K	--
<b>Steel and Iron</b> - Industrial Equipment (Exposed to Potable water):																				
Shop primed, field finished	B	A	I or A	B	B	B	D	I	B	B	B	D	I	B	--	--	--	--	B	--
<b>Exposed to Potable water</b> (NSF) completely shop coated, inside and out, OEM factory finished items such as Gates, Valves etc.	B	A	I or A	B	A	B	D	I	B	A	B	D	I	B	A	--	--	--	--	--



**GENERAL SPECIFICATION 09900 -- PAINTING**

<b>MATERIAL PAINTING SCHEDULE</b>																				
<b>Materials and Conditions</b>	<b>Paint Groups (A-N)</b>																			
	<b>Tn: Tnemec, Cb: Carboline, SW: Sherwin Williams, IP: International paint, PPG: PPG/Amercoat</b>																			
	<b>Prime Coat</b>					<b>Finish Coats</b>														
						<b>1<sup>st</sup></b>					<b>2<sup>nd</sup></b>					<b>3<sup>rd</sup></b>				
<b>Paint Manufacturer</b>	Tn	Cb	SW	IP	PPG	Tn	Cb	SW	IP	PPG	Tn	Cb	SW	IP	PPG	Tn	Cb	SW	IP	PPG
Equipment above grade, indoors, <b>exposed to Potable water</b> (NSF), completely shop coated inside and out, OEM factory finished items such as Gates, Valves etc.	B	A	I or A	B	A	B	D	I	B	A	A	D	I	B	A	--	--	--	--	--
Equipment above grade, outdoors, <b>exposed to Potable water</b> (NSF), completely shop coated inside and out, OEM factory finished items such as Gates, Valves etc.	N*	A	I or A or N*	B	B	--	D	I	B	--	--	D	I	B	--	--	--	--	--	--
Ductile Iron or steel process piping <b>exposed to Potable Water</b> (shop finished) alternate	N*	A or N*	A or I Or N*	B	B	--	A	I	B	B	--	C	I	B	--	--	--	--	--	--
<b><u>MISCELLANEOUS USES:</u></b>																				
<b>Piping</b> concealed in Masonry	B	A	A	A	B	A	A	D	A	B	A	--	D	A	B	--	--	--	--	--
<b>Piping</b> wrapped in Insulation	A	A	A or D	A or B	B	A	A	D	A or B	B	A	--	D	A or B	B	--	--	--	--	--

**GENERAL SPECIFICATION 09900 -- PAINTING**

<b>MATERIAL PAINTING SCHEDULE</b>																				
<b>Materials and Conditions</b>	<b>Paint Groups (A-N)</b>																			
	<b>Tn: Tnemec, Cb: Carboline, SW: Sherwin Williams, IP: International paint, PPG: PPG/Amercoat</b>																			
	<b>Prime Coat</b>					<b>Finish Coats</b>														
						<b>1<sup>st</sup></b>					<b>2<sup>nd</sup></b>					<b>3<sup>rd</sup></b>				
<b>Paint Manufacturer</b>	Tn	Cb	SW	IP	PPG	Tn	Cb	SW	IP	PPG	Tn	Cb	SW	IP	PPG	Tn	Cb	SW	IP	PPG
<b>Heated Metal</b> (Air Main Piping): Submerged, Buried and Exposed	L or M*	D or E or M*	D or M*	D	D	--	E	D	D	D	--	A	D	D	--	--	A	D	D	--
Concrete Masonry: Interior	F	--	D	--	F	D or A	F	F	F	B	D	A	D	D	B	D	A	D	D	--
<b>Concrete:</b> Interior excluding floors	A	G	--	--	B	D or A	A	D	D	B	D	A	D	D	B	--	--	--	D	--
<b>Concrete:</b> Immersion, Waste Water	A	--	--	--	D	A	J	J	J or D	D	A	K	B or K	D	--	A	--	B	K or D	--
Pipe and Duct Insulation: Exposed	A	--	--	--	B	H	B	H	H	B	H	H	H	H	B	--	--	--	--	--
PVC (Interior)	A	--	--	--	B	A	B	D	A	B	A	A	D	A	--	--	--	--	--	--
PVC (Exterior)	A	--	--	--	B	A	B	D	A	C	A	C	C	A	--	C	--	C	C	--
Gypsum Wallboard and Plaster:	G	--	--	--	G	H	G	G	G	H	H	H	H	H	--	H	H	H	H	--

**GENERAL SPECIFICATION 09900 -- PAINTING**

**MATERIAL PAINTING SCHEDULE**

<b>Materials and Conditions</b>	<b>Paint Groups (A-N)</b>																			
	<b>Tn: Tnemec, Cb: Carboline, SW: Sherwin Williams, IP: International paint, PPG: PPG/Amercoat</b>																			
	<b>Prime Coat</b>					<b>Finish Coats</b>														
						<b>1<sup>st</sup></b>					<b>2<sup>nd</sup></b>					<b>3<sup>rd</sup></b>				
<b>Paint Manufacturer</b>	Tn	Cb	SW	IP	PPG	Tn	Cb	SW	IP	PPG	Tn	Cb	SW	IP	PPG	Tn	Cb	SW	IP	PPG
Nonferrous Metal and Galvanized steel: Interior	A	--	--	--	B	A	B	D	A	B	A	A	D	A	--	A	--	D	A	--
Nonferrous Metal and Galvanized Steel: Exterior	A	--	--	--	B	A	B	D	A	C	A	C	C	A	--	C	--	C	C	--
*Require only one coat.																				

END OF SECTION

**GENERAL SPECIFICATION 09900 -- PAINTING**

---

NO TEXT ON THIS PAGE

**SECTION 10200  
Louvers**

**PART 1 GENERAL**

**1.01 SECTION INCLUDES**

- A. Furnish all labor, materials, equipment and appliances required for the complete execution of the work as shown on the Contract Drawings and specified under the several chapters of the Specifications.
- B. The extent of louver work is shown on the Contract Drawings and includes the following:
  - 1. Individual louver openings where indicated.
  - 2. Blank-off metal panels where required.
  - 3. Bird screen or insect screen as required.
  - 4. Removal sections of louver where it indicated on the Contract Drawings.
- C. The following index of this Section is presented for convenience:

<u>Article</u>	<u>Title</u>	<u>Page</u>
		10200-
PART 1	GENERAL.....	1
1.01	Section Includes.....	1
1.02	Related Sections.....	2
1.03	Payment.....	2
1.04	Codes And Standards.....	2
1.05	Submittals.....	2
1.06	Delivery, Storage And Handling.....	3
PART 2	PRODUCTS.....	3
2.01	Acceptable Manufacturers.....	3
2.02	Materials.....	3
2.03	System Performance Requirements.....	4
2.04	Finish.....	5
PART 3	EXECUTION.....	5
3.01	Installation.....	5
3.02	Cutting And Fitting.....	6
3.03	Cleaning.....	6

## GENERAL SPECIFICATION 10200 - LOUVERS

---

### 1.02 RELATED SECTIONS

- A. General Specification 05061 - Stainless Steel Work.
- B. General Specification 07900 - Caulking and Sealants.

### 1.03 PAYMENT

- A. No direct payment will be made for louvers, accessories or appurtenances; the cost shall be included in the prices for the work, except as provided for in the Detailed Specifications.

### 1.04 CODES AND STANDARDS

- A. New York City Building Code.
- B. ASTM A276 - Stainless Steel Bars and Shapes, Standard Specification for.
- C. ASTM A320 - Alloy Steel Bolting Materials for Low Temperature Service, Specification for.
- D. ASTM A666 - Annealed or Cold-Worked Austenitic Stainless Steel Sheet, Strip, Plate and Flat Bar, Standard Specification for.
- E. ASTM F593 - Stainless Steel Bolts, Hex Cap Screws and Studs, Standard Specification for.
- F. ASTM F594 - Stainless Steel Nuts, Standard Specification for.
- G. ANSI/ASSE A1264.1 - Safety Requirements for Workplace Walking/Working Surfaces and Their Access; Workplace, Floor, Wall and Roof Openings; Stairs and Guardrail/Handrail Systems.
- H. AWS A5.12 - Tungsten and Tungsten Alloy Electrodes for Arch Welding and Cutting.
- I. 29 CFR 1910.23 - Guarding Floor and Wall Openings and Holes.

### 1.05 SUBMITTALS

- A. Contractor shall submit Shop Drawings for approval of the Engineer. Submittals shall include, but not be limited to:
  - 1. Samples.
  - 2. Shop Drawings.
- B. Samples shall include color and finish samples for each finish type required.

- C. Shop drawings of louver units and accessories shall include plans, elevation, sections and details showing profiles, angles, spacing of louver blades, unit dimensions related to wall openings and construction; free areas for each size indicated; profiles of frames at jambs, head and sills.
  - 1. Where installed products are indicated to comply with certain structural design loadings, include structural computations, material properties and other information needed for structural analysis, which has been prepared by or under the supervision of a qualified Professional Engineer.
- D. Product test reports evidencing compliance of units with performance requirements indicated.
- E. Products certificates signed by louver manufacturers certifying that their products, which comply with project requirements, are licensed to bear the AMCA seal based on tests made in accordance with AMCA Standard 500 and complying with AMCA Certified Ratings Program.
- F. Samples: submit samples, 6" square, of equal type of metal of the same gauge and alloy to be used in the work.

1.06 DELIVERY, STORAGE AND HANDLING

- A. Brace and support units to prevent deformation during delivery.
- B. Factory wrap units with approved materials to protect finish during delivery and storage.
- C. Handle units with care to prevent bending or scratching.

PART 2 PRODUCTS

2.01 ACCEPTABLE MANUFACTURERS

- A. The Airolite Co, Schofield, WI.
- B. Penn Ventilator Co., Inc, Birmingham, AL.
- C. Or approved equal.

2.02 MATERIALS

- A. Double Drainable Fixed Louver
  - 1. Individual louver shall be Airflex Industrial Model No. FDD-6-SS; fixed 45 degree, 6" deep dual drainable storm-proof blade of the following characteristics:
    - a. Frames and blades shall be stainless steel 316 alloy .064" thick.

**GENERAL SPECIFICATION 10200 - LOUVERS**

---

- b. Fasteners: Of same basic metal and alloy as fastened metal, unless otherwise indicated. Do not use metals, which are corrosive or incompatible with materials joined.
    - 1) Use types, gages and lengths to suit unit installation conditions.
    - 2) Use Philips flat-head machine screws for exposed fasteners unless otherwise indicated.
  - c. Anchors and inserts of type, size and material required for type of loading and installation indicated. Use Type 316 stainless steel anchors and inserts for exterior installation and elsewhere as required for corrosion resistance.
  - d. Bituminous Paint: SSPC-Paint 12 (cold-applied asphalt mastic).
2. Manufacturer to submit test data on 4 feet x 4 feet louver units. Test data shall show the following results at 1100 fpm free area velocity.

<b>Minimum Free Area</b>	<b>Maximum Pressure Drop</b>	<b>Maximum Water Penetration</b>
7.32 sq. ft	0.24 in	0.005 oz
0.678 m	6.10 mm	1.53 g

**2.03 SYSTEM PERFORMANCE REQUIREMENTS**

- A. Structural Performance: Design, engineer, fabricate and install metal louvers to withstand the effects of loads and stresses from wind and normal thermal movement without evidencing permanent deformation of louver components including blades, frames and supports, noise or metal fatigue caused by louver blade rattle or flutter; and permanent damage to fasteners and anchors.
  - 1. Wind Load: Uniform pressure (velocity pressure) of 30 lbf per sq. ft. acting inwards or outwards.
  - 2. Normal thermal movement is defined as that resulting from the following maximum change (range) in ambient temperature. Base design calculations on actual surface temperatures of metals due to both solar heat gain and nighttime sky heat loss.
    - a. Temperature Change (Range): 100 deg. F (55.5 deg. C)



## GENERAL SPECIFICATION 10200 - LOUVERS

---

- B. Air-Performance, Water-Penetration and Air-Leakage Ratings: Provide louvers complying with performance requirements indicated as demonstrated by testing manufacturer's stock units of height and width indicated according to Air Movement and Control Association (AMCA) Standard 500.

### 2.04 FINISH

- A. Exposed sides of all stainless steel components shall be Type 4 polished finish in accordance with General Specification 05061 - Stainless Steel Work, as per the Engineer's approved sample.

## PART 3 EXECUTION

### 3.01 INSTALLATION

- A. Anchor louver frames using stainless steel bolts into holes drilled and tapped in subframes or with strap anchors to masonry in accordance with the manufacturer's approved directions.
- B. Isolate aluminum from contact with masonry or dissimilar metals with heavy coat of bituminous paint or neoprene gaskets.
- C. Mount bird screens of all louvers unless indicated otherwise on inside face with clips, machine screw into frames. Screws shall be stainless steel.
- D. Verify size, location and placement of continuous louvers and individual louver units prior to fabrication wherever possible. Coordinate field measurement and shop assembly to minimize field adjustment. It is important to recognize that both fabrication and installation shall be done by the same company in order to achieve the quality required.
- E. Locate and place louver unit's plumb, level and in proper alignment.
- F. Use concealed anchorages where possible. Provide brass or lead washers fitted to screws where required to protect metal surfaces and to make a weather-tight connection.
- G. Form closely fitted joints with exposed connections accurately located and secured.
- H. Provide perimeter reveals and openings of uniform width for sealants and joint fillers as indicated.
- I. Repair finishes damaged by cutting, welding, soldering and grinding operations required for fitting and jointing. Restore finishes so there is no evidence of corrective work. Return items which cannot be refinished in the field to the shop, make required alterations and refinish entire unit or provide new units.

## GENERAL SPECIFICATION 10200 - LOUVERS

---

- J. Install concealed gaskets, flashings, joint fillers and insulation as louver installation progresses where required to make louver joints weather-tight. Comply with General Specification 07900 - Caulking and Sealants for sealants applied during installation of louver.
- K. Protect louvers and vents from damage of any kind during construction period including use of temporary protective coverings where needed and approved by louver manufacturer. Remove protective covering at time of final acceptance.
- L. Restore louvers and vents damaged during installation and construction period so that no evidence remains of correction work. If results of restoration are unsuccessful, remove damaged units and replace with new units.

### 3.02 CUTTING AND FITTING

- A. Do all cutting and fitting required for the installation in a neat manner.

### 3.03 CLEANING

- A. Upon completion remove any and all protective coatings, and clean off all parts of the work in accordance with Contract Document.

END OF SECTION

**SECTION 10400  
Identifying Devices**

**PART 1 GENERAL**

**1.01 SECTION INCLUDES**

- A. Identifying devices as specified herein shall include, safety signs, bulletins boards, stand signs, stand signs, raised signs, safety strips tape, and appurtenances.
- B. Identifying devices shall be provided where shown on the Contract Drawings, specified in the Detailed Specifications, or as required for a complete installation.
- C. The Contractor shall implement practices and procedures to meet the project's sustainability goals as identified in the Contract Documents. The Contractor shall ensure that the sustainability requirements of this Section are implemented to the fullest extent.
- D. The following index of this Section is presented for convenience:

<u>Article</u>	<u>Title</u>	<u>Page</u>
		10400-
PART 1	GENERAL .....	1
1.01	Section Includes .....	1
1.02	Payment.....	2
1.03	References.....	2
1.04	System Design Requirements .....	2
1.05	Quality Assurance.....	2
1.06	Submittals .....	2
1.07	Delivery, Storage And Handling.....	3
PART 2	PRODUCTS.....	4
2.01	Manufacturers .....	4
2.02	Materials .....	5
2.03	Accessible Room Identification Information And Directional Signs.....	10
PART 3	EXECUTION.....	10
3.01	Examination .....	10
3.02	Installation.....	10
3.03	Identifying Device Locations.....	10
3.04	Protection .....	10
3.05	Adjustment.....	11
3.06	Cleaning .....	11

## GENERAL SPECIFICATION 10400 - IDENTIFYING DEVICES

---

### 1.02 PAYMENT

- A. No separate payment will be made for performing any work of this Section and all costs associated thereof shall be included in the lump sum price bid for the Contract, except as provided for in the Detailed Specifications.

### 1.03 REFERENCES

- A. OSHA - 1910.145
- B. OSHA - 1910.157
- C. NYCBC -- New York City Building Code
- D. ANSI/ICC A117.1 - Accessible and Usable Buildings and Facilities

### 1.04 SYSTEM DESIGN REQUIREMENTS

#### A. Sustainable Design Requirements

1. Adhesives: As recommended by sign manufacturer and with a VOC content of 70 g/L or less for adhesives used inside the weatherproofing system and applied on-site when calculated according to 40 CFR 59, Subpart D (EPA Method 24).
2. Adhesives: Do not use adhesives that contain added urea formaldehyde.
3. Composite Wood and Agrifiber Products: Do not use composite wood and agrifiber products that contain added urea formaldehyde.

### 1.05 QUALITY ASSURANCE

- A. Quality assurance requirements will be provided if necessary in the Detailed Specifications.

### 1.06 SUBMITTALS

- A. Contractor shall submit Shop Drawings for approval of the Engineer. Submittals shall include, but not be limited to: catalog cuts, drawings and reference materials.
- B. Shop Drawings: The following items shall be submitted:
  1. The Contractor shall submit copies of specifications, installation instructions and general recommendations from the identifying device manufacturers, for each type of identifying device product. Manufacturer's data substantiating that the materials comply with the requirements of the Contract Documents shall be included.

## GENERAL SPECIFICATION 10400 - IDENTIFYING DEVICES

---

2. Drawings showing extent of the Work and all details required for the Work referencing system components provided as samples. Drawings shall include, the following
    - a. Complete details for all signs giving sizes and styles of lettering and colors.
    - b. Complete schedules for all nameplates, signs, and building name letters giving location, message, letter, size, color, and method of attachment.
    - c. Details of fabrication and attachment of all items.
    - d. Complete location plan for all sign types.
  - C. Samples: Submit for approval color and finish samples of each identifying device product, including each accessory and miscellaneous material to be used in the Work.
  - D. Sustainable Design Submittals
    1. Environmental Materials Reporting Form (EMRF) Recycled Content Materials. Provide the following information:
      - a. Name of Product and Manufacturer.
      - b. Material cost breakdowns. Cost breakdowns must include total material-only cost (excluding installation, labor and equipment).
      - c. The percentage (by weight) of post-consumer and pre-consumer recycled content in the submitted product(s), if applicable.
    2. Environmental Materials Reporting Form (EMRF) - Composite Wood Products. Include the following information:
      - a. Confirmation that composite wood and Agrifiber products contain no added urea formaldehyde.
      - b. For each laminate adhesive used on site and in the shop, documentation indicating that the adhesive contains no added urea formaldehyde.
    3. VOC Reporting Form. Provide the following information:
      - a. For all adhesives used on site, provide the VOC content in grams/Liter (g/L) less water and other exempt compounds.
- 1.07 DELIVERY, STORAGE AND HANDLING
- A. Delivery of Materials:

## GENERAL SPECIFICATION 10400 - IDENTIFYING DEVICES

---

1. Materials shall not be delivered to the project site before the time of installation.
  2. Materials shall be delivered in sufficient quantities to allow continuity of the Work.
- B. Storage of Materials:
1. Materials shall be stored in original, undamaged containers with manufacturer's labels and seals intact.
  2. All materials shall be stored in a dry, enclosed area, off the ground and away from all possible contact with water, ice or snow.
  3. Damage to materials during storage shall be prevented by minimizing the amount of time they are stored at the site before being incorporated into the Work.
- C. Handling of Materials:
1. Materials shall be handled in such a manner to avoid damage or breakage.
  2. Materials shall not be exposed to detrimental conditions or physical damage. Materials which are so exposed shall be removed from the site and shall not be incorporated into the Work.
  3. Packages or containers shall not be opened until all necessary preparatory Work is complete and installation is to begin immediately. Materials shall not be allowed to become wet or soiled or covered with ice or snow.

## PART 2 PRODUCTS

### 2.01 MANUFACTURERS

- A. Acceptable products as manufactured by the manufacturers listed below. Other manufacturers of equivalent products may be submitted for approval by the Engineer.
1. Standard Signs, Raised Signs, Projected Signs, and Floor Diagram Exit Signs:
    - a. Sign & Graphics, Inc. Birmingham, AL (phenolic photo polymer and acrylic material)
    - b. Advance Corporation, St. Paul, MN (magnesium alloy material)
    - c. Or approved equal.

2. Bulletin and Directory Boards:
  - a. Southwell Company, San Antonio, TX.
  - b. Or approved equal.
3. Safety Stripes Tape
  - a. Permacel - P-32
4. Safety/Regulatory Signs
  - a. Lab Safety Supply - Janesville, WI.
  - b. Brady Signmark Division, Milwaukee, WI.
  - c. Or approved equal.
5. Metal Letters and Numbers (exterior)
  - a. Nelson-Harking Industries, Chicago, IL.
  - b. Or approved e.

2.02 MATERIALS

A. General:

1. Accessibility Standard: Comply with applicable provisions in ICC A117.1 for signs.

B. Standard Signs: Standard signs shall be as follows:

1. All letters, numbers and/or symbols shall contrast with their background and shall consist of either white characters on a dark background, or black characters on a light background.
2. Sign characters and background shall have satin finish.
3. Plate material shall be:
  - a. Acrylic approximately 1/8-inch thick, with surface painted, both face and returns. Coating shall be acrylic polyurethane paint, satin finish color shall be as selected from manufacturer's standard.
  - b. Laminated phenolic engraving stock approximately 1/8-inch thick.
  - c. Magnesium alloy, approximately 1/8 inch thick, with baked acrylic polyurethane finish. One piece construction, process-chemical etch.
4. Lettering style shall be Helvetica medium, upper case.
5. Corners shall be 1/4-inch radius.

## GENERAL SPECIFICATION 10400 - IDENTIFYING DEVICES

---

6. All mounting hardware shall be provided, with the manufacturer's standard holes and screws.
- C. Raised signs shall be as follows:
1. Raised signs shall be of the three-in-one construction style having the following characteristics:
    - a. One-piece construction with tactile characters and symbols raised 1/32-inch from sign plate face. Added-on or engraved characters are unacceptable.
    - b. Grade 2 braille raised 1/32-inch from sign plate face and placed directly below each line of letters or numbers. Braille shall remain color of faceplate.
    - c. All letters, numbers and symbols shall contrast with their background and shall consist of either white characters on a dark background or black characters on a light background.
  2. Plate material shall be:
    - a. Phenolic photo polymer, approximately 1/8-inch thick, with surface painted, both face and returns. Coating shall be acrylic polyurethane paint, satin finish, color selected from manufacturer's standard.
    - b. Magnesium alloy, approximately 1/8 inch thick, with baked acrylic polyurethane finish. One piece construction, process-chemical etch.
  3. Lettering style shall be Helvetica medium, upper case.
  4. Corners shall be 1/4-inch radius.
  5. All mounting hardware shall be provided, with manufacturer's standard holes and screws.
  6. Door numbers and room name plates shall be made from laminated phenolic engraving stock, with 3/4-inch high standard block lettering. Door numbers shall be centered on frames. Room names shall be centered on doors, 5'-6" above finished floor. Door plates shall be 1-1/2 inches high, 4 inches long for door numbers; 2-1/2 inches high and varying length for names. Provide door numbers and room name plates on all doors or all designated rooms indicated on the Room Finish Schedule on the Contract Drawings.



## GENERAL SPECIFICATION 10400 - IDENTIFYING DEVICES

---

- a. Provide personalized name plates for each office, and international handicapped symbols for every toilet with handicapped accommodation.
  - b. Provide braille translation cast into background to all rooms 1000 sf or larger, excluding storage areas, and all rest rooms.
- D. Projected signs shall be as follows:
1. All letters, numbers and/or symbols shall contrast with their background and shall consist of either white characters on a dark background, or black characters on a light background.
  2. Plate material shall consist of phenolic photo polymer, approximately 1/8-inch thick, with surface painted, including both sides and all edges.
  3. Projected sign shall be mounted to bracket with two small screws and nuts.
  4. Lettering style shall be Helvetica medium, upper case.
  5. Corners shall be 1/4-inch radius.
  6. Finish shall be acrylic polyurethane coating, color shall be as selected from manufacturer's standard.
  7. Mounting hardware for each projected sign shall consist of a 4 inch high aluminum bracket with satin silver finish. The bracket shall be mounted to wall surface with four countersunk screw type anchors.
- E. Floor Diagram Exit Signs: Fire evacuation schematics sign shall be as follows:
1. All letters, numbers and symbols shall contrast with the color of the background material. Window plate shall have white characters on dark background, with matte finish. Removable insert shall have black characters on light background.
  2. Window plate material shall consist of matte acrylic, approximately 1/16 inch thick with the surface screened and painted. Window slot shall remain clear, and shall be mounted to backplate with 1/16-inch clear acrylic which spacer for the insert extended to the edge.
  3. Backplate material shall consist of Komatex of the same size as window plate. Backplate material shall be approximately 1/8-inch thick and color shall be white.
  4. Removable insert material shall consist of paper stock.

## GENERAL SPECIFICATION 10400 - IDENTIFYING DEVICES

---

5. Lettering style shall be Helvetica medium, upper case.
  6. Finish shall be acrylic polyurethane coating, color shall be as selected from manufacturer's standard.
  7. All mounting hardware shall be provided, with the manufacturer's standard holes and screws.
- F. Bulletin and directory boards shall be as follows:
1. Enclosed units, including frame and glazed door.
  2. Overall size of 23-1/4 inches wide by 19-1/2 inches high.
  3. Removable strip retainer panel, plywood back and integral header section with lettering.
  4. Door frame of extruded aluminum, 6063-T5 alloy, glazed with 1/4-inch thick polished tempered glass, and furnished with a cylinder lock and two keys.
  5. All exposed aluminum shall be clear anodized with a satin finish.
  6. Surface mounted in accordance with the manufacturer's instructions, and with manufacturer's standard concealed mounting hardware.
- G. Safety and regulatory shall conform to OSHA Regulations 1910.145 and 1910.157 and shall be as follows:
1. Accident prevention signs are classified as follows:
    - a. Danger signs shall indicate an immediately hazardous situation which, if not avoided, will result in death or serious injury. Danger is limited to the most extreme situations. Color scheme shall be red, black and white.
    - b. Warning signs shall indicate a potentially hazardous situation which, if not avoided, could result in death or serious injury. Color scheme shall be orange background, with a black and orange panel with black letters.
    - c. Caution signs shall indicate a potentially hazardous situation which, if not avoided, may result in minor or moderate injury. Caution signs may also be used to alert against unsafe practices. Color scheme shall be yellow background, with a black panel with yellow letters.
    - d. Notice signs shall indicate a statement of company policy as the message relates directly or indirectly to the

- safety of personnel or protection of property. Color scheme shall be white background, with a blue panel with white letters.
- e. General safety signs shall indicate general instructions relative to safe work practices, reminders of property safety procedures, and the location of safety equipment. Color scheme shall be white background, with a green panel with white letters.
  - f. Fire prevention signs shall indicate the location of exit or emergency firefighting equipment. Color shall be red and white.
  - g. Directional arrow signs shall indicate the direction to exit, emergency equipment, safety equipment and other locations important to safety. Color shall be red and black.
- 2. Plate material shall be:
    - a. Fiberglass reinforced polyester with protected graphics, approximately 0.10-inch thick.
    - b. Rigid acrylic, approximately 1/8 inch thick.
    - c. Aluminum plate thickness 1/16 inch thick with overlaminated graphics.
  - 3. Lettering style shall be Helvetica medium, upper case.
  - 4. All mounting hardware shall be provided, with manufacturer's standard holes and screws.
- H. Safety Stripes Tape: Tape shall meet the requirements of OSHA 1910.144 and shall be as follows:
- 1. Tape shall be 2-inch wide pressure sensitive reinforced vinyl tape, white with black stripes.
  - 2. A minimum of 50 yards of the tape shall be provided and shall be installed as directed by the Engineer.
- I. Metal Letters and Numbers (Exterior)
- 1. Provide metal letters and numbers to comply with the requirements of the Detailed Specifications for name, material, size, style, stroke, depth and finish.
  - 2. Form letters and numbers by casting. Produce characters with smooth, flat faces, sharp corners, and precisely-formed lines and profiles, free from pits, scale, sand holes or other defects.. Cast

## **GENERAL SPECIFICATION 10400 - IDENTIFYING DEVICES**

---

lugs into the back of the characters and tap to receive threaded mounting studs.

- J. Attachments: All attachments and anchors necessary for concealed installments of identifying devices and bulletin boards shall be furnished.

### **2.03 ACCESSIBLE ROOM IDENTIFICATION INFORMATION AND DIRECTIONAL SIGNS**

- A. Accessible Room Identification Signs: Schedule of room names will be supplied by the Engineer after Award of Contract. Every interior door shall receive two plaques.
- B. Accessible Restroom Identification Signs: Every door entering all toilet rooms shall be supplied with either a MEN'S or WOMEN'S pictogram with contrasting color text, and with an International Symbol of Accessibility pictogram and ADA-compliant Grade 2 Braille alphabet descriptions.

## **PART 3 EXECUTION**

### **3.01 EXAMINATION**

- A. The Contractor shall verify that areas to receive identifying devices are properly prepared and completed.

### **3.02 INSTALLATION**

- A. All materials specified herein shall be installed in compliance with the New York City Building Code, ANSI A117, OSHA regulations, and the approved manufacturer's printed specifications. Mounting devices, bolts, screws, nuts, and the like shall be of high strength aluminum or stainless steel.
- B. Identifying devices shall be installed after final field finish has been applied and thoroughly dried.

### **3.03 IDENTIFYING DEVICE LOCATIONS**

- A. Identifying devices shall be installed where shown on the Contract Drawings and as specified in the Detailed Specifications.

### **3.04 PROTECTION**

- A. Identifying devices shall be protected from all damage and abuse from all other Contractors and installers involved in the Work until Final Acceptance by the City.

## **GENERAL SPECIFICATION 10400 - IDENTIFYING DEVICES**

---

### 3.05 ADJUSTMENT

- A. System components which are dislodged, damaged, expanded, broken, penetrated or crushed by subsequent installation operations or damaged by detrimental weather shall be immediately replaced with undamaged material in compliance with the Sections and properly protected as specified.

### 3.06 CLEANING

- A. Upon completion of the project, all protection devices shall be removed and identifying devices shall be touched up as necessary. All exposed surfaces shall be cleaned using a mild solution of detergent and warm water. All surfaces shall be left in a neat and clean condition.

END OF SECTION

NO TEXT ON THIS PAGE

**SECTION 10500  
Lockers and Benches**

**PART 1 GENERAL**

**1.01 SECTION INCLUDES**

- A. This Section includes metal lockers and benches in the sizes, quantities and arrangements, indicated on the Contract Drawings and specified herein, required for a complete installation.
- B. The following index of this Section is presented for convenience:

<u>Article</u>	<u>Title</u>	<u>Page</u>
		10500-
PART 1	GENERAL .....	1
1.01	Section Includes .....	1
1.02	Payment.....	1
1.03	References.....	1
1.04	Sustainable Design Requirements.....	2
1.05	Quality Assurance.....	2
1.06	Submittals .....	2
1.07	Delivery, Handling And Storage.....	3
PART 2	PRODUCTS.....	3
2.01	Manufacturers .....	3
2.02	Materials .....	3
2.03	Accessories .....	4
2.04	Benches.....	4
PART 3	EXECUTION.....	5
3.01	Locker Installation .....	5
3.02	Bench Installation .....	5
3.03	Cleaning .....	5

**1.02 PAYMENT**

- A. Unless otherwise provided in the Detailed Specifications, no separate payment will be made for performing any Work required under this Section and the Contractor shall include all costs thereof in its lump sum price bid for the Contract.

**1.03 REFERENCES**

- A. ICC/ANSI A117.1 - Accessible and Usable Buildings and Facilities.
- B. NYCBC - New York City Building Code

## GENERAL SPECIFICATION 10500 – LOCKERS AND BENCHES

---

- C. NFPA - National Fire Protection Association
- D. ASTM E 84 - Standard Test Method for Surface Burning Characteristics of Building Materials

### 1.04 SUSTAINABLE DESIGN REQUIREMENTS

- A. Recycled Content of Metal Lockers: Postconsumer recycled content plus one-half of preconsumer recycled content not less than 25 percent.
- B. Composite Wood and Agrifiber Products: Do not use composite wood and agrifiber products that contain added urea formaldehyde.
- C. Adhesives: Do not use adhesives that contain added urea formaldehyde.

### 1.05 QUALITY ASSURANCE

- A. Lockers and benches required under this Contract shall be provided by a single manufacturer.

### 1.06 SUBMITTALS

- A. The Contractor shall submit shop drawings, samples and other information to the Engineer for review. Shop drawings shall include, but not be limited to:
  - 1. Dimensions affecting locker installation,
  - 2. Locations of fillers,
  - 3. Trim,
  - 4. Accessories and
  - 5. Numbering sequence.
- B. Submit small properly identified samples of metal indicating color and finish.
- C. Provide installation instructions from locker manufacturer.
- D. Provide color chart of manufacturer's full range of colors.
- E. Sustainable Design Submittals:
  - 1. Environmental Materials Reporting Form (EMRF) Recycled Content and Regional Materials. Provide the following information:
    - a. Name of Product and Manufacturer.
    - b. Material cost breakdowns. Cost breakdowns must include total material-only cost (excluding installation, labor and equipment).



- c. The percentage (by weight) of post-consumer and pre-consumer recycled content in the submitted product(s), if applicable.
- 2. Environmental Materials Reporting Form (EMRF) - Composite Wood Products. Include the following information:
  - a. Confirmation that composite wood and Agrifiber products contain no added urea formaldehyde.
  - b. For each laminate adhesive used on site and in the shop, documentation indicating that the adhesive contains no added urea formaldehyde.

1.07 DELIVERY, HANDLING AND STORAGE

- A. Lockers shall not be delivered until building is ready for their installation. Protect from damage during delivery, handling, storage and installation.

PART 2 PRODUCTS

2.01 MANUFACTURERS

- A. Locker and benches shall be as manufactured by:
  - 1. Lyon Metal Products Co., Montgomery, IL.
  - 2. Penco Products, Skippack, PA.
  - 3. Or approved equal.

2.02 MATERIALS

- A. Accessibility Requirements: For lockers indicated to be accessible, comply with applicable provisions in ICC A117.1.
- B. Lockers shall be single tier or multi-tier single compartment in sizes as listed below with prefabricated bases, "Heavy Duty Corridor Locker". Quantities and locations shall be as indicated on the Contract Drawings. All lockers shall have louvers for ventilation.
  - 1. 15 inches wide x 18 inches deep x 72 inches high (single tier).
  - 2. 24 inches wide x 18 inches deep x 72 inches high (single tier);
  - 3. 12 inches wide x 12 inches deep x (6 tiers) for a full height of 72 inches.
  - 4. 18 inches wide x 18 inches deep x (4 tiers) for a full height of 72 inches.

## GENERAL SPECIFICATION 10500 – LOCKERS AND BENCHES

---

- C. Locker body shall be fabricated of 24 gauge, annealed, cold rolled steel free from surface imperfections. Fasteners shall be zinc plated steel. Exposed bolt heads shall be of the slotless type.
- D. Doors shall be 14 gauge with both vertical edges formed into channel shaped formations. Top and bottom shall be flanged at 90 degree angle. Doors shall be provided with louvers, top and bottom.
- E. Door handles shall be die-cast with polished, plated finish. Handle shall have concealed lock eye and lock strike which is an integral part of the handle.
- F. Finish shall be phosphatized surface preparation, baked enamel finish, in custom colors as selected by the Engineer.
- G. Lockers shall be furnished with steel trimming strips and sloped tops, to cover the gaps at the ends, or steel filler plates at each section of lockers. Filler plates shall be provided to cover units at intersections and spaces between units and walls and top of units at corners. Trimming strips and filler plates shall be #16 ga. steel, finished to match the lockers. Lockers shall have 6 inch high #16 ga. steel sanitary base cone, to match locker body.

### 2.03 ACCESSORIES

- A. The following accessories shall be provided:
  - 1. Coat hooks - Zinc, or nickel plated.
  - 2. Locks - Built-in key operated lock with two keys and master key.
  - 3. Number Plates - Aluminum plates with 3/8 inch high embossed figures.
  - 4. Sloping hoods - 20 gauge steel finished to match lockers.
  - 5. Shelves - one shelf per locker.
  - 6. ADA Complaint Hardware and Locker where indicated on the Contract Drawings.

### 2.04 BENCHES

- A. Benches shall have clear hardwood tops, made with adhesive containing no urea formaldehyde, 9-1/2 inches wide x 1-1/4 inches thick, finished with three coats of plastic sealer. Benches shall be supported by steel pedestals spaced not more than 6 feet apart, finished to match lockers. The overall height of bench shall be 18 inches, lengths as noted on Contract Drawings.

PART 3 EXECUTION

3.01 LOCKER INSTALLATION

- A. Locker shall not be delivered until building is ready for their installation. Protect from damage during delivery, handling, storage and installation.
- B. Fasteners shall be spaced about 48 inches on center and applied through back-up reinforcing plates where necessary to prevent metal distortion. Fasteners shall be concealed where possible.
- C. Adjust doors and latches to operate easily without bind.

3.02 BENCH INSTALLATION

- A. Secure pedestals to floor slab with suitably sized Rawl "Saber-Tooth", or approved equal, self-drilling, stainless steel anchors.

3.03 CLEANING

- A. The Contractor shall touch-up marred finishes, or replace, if not acceptable to the Engineer. All lockers shall be clean and operating properly prior to acceptance by the Engineer.

END OF SECTION

NO TEXT ON THIS PAGE

**SECTION 10521  
Fire Extinguishers**

**PART 1 GENERAL**

**1.01 SECTION INCLUDES**

- A. Furnishing and installing fire extinguishers as shown on the Contract Drawings and/or specified herein.
- B. The following index of this Section is presented for convenience:

<u>Article</u>	<u>Title</u>	<u>Page</u>
		10521-
PART 1	GENERAL .....	1
1.01	Section Includes .....	1
1.02	Payment.....	1
1.03	References.....	1
1.04	Submittals .....	1
PART 2	PRODUCTS.....	2
2.01	Manufacturers .....	2
2.02	Fire Extinguishers .....	2
2.03	Materials .....	2
PART 3	EXECUTION.....	3
3.01	Installation.....	3

**1.02 PAYMENT**

- A. Payment for all Work required under this Section will be made as described in the Detailed Specifications.

**1.03 REFERENCES**

- A. NFPA 10 - Portable Fire Extinguishers.

**1.04 SUBMITTALS**

- A. Contractor shall submit Shop Drawings for approval of the Engineer.
- B. Shop Drawings shall include, but not be limited to:
  - 1. Manufacturer's specification data sheets and verification of UL ratings.
  - 2. Complete detail and installation drawings for Fire Extinguisher Cabinets.
  - 3. Wall mounted hardware.

PART 2 PRODUCTS

2.01 MANUFACTURERS

1. As manufactured by:
  - a. Kidde [Fenwal](#) Inc., Ashland, MA.
  - b. Ansul Inc., Marinette, WI.
  - c. Potter – Roemer Inc., Union, NJ.
  - d. Firemaster, Fort Myers, FL.
  - e. Or approved equal.

2.02 FIRE EXTINGUISHERS

- A. Refer to the Detailed Specifications or the Contract Drawings for a Fire Extinguisher Schedule.

2.03 MATERIALS

- A. Dry Chemical (DC) fire extinguishers shall be 10 lb. capacity, cartridge operated, hand portable, with wall mount, tri-class dry chemical type, with Underwriters' Laboratories rating of 4-A: 60 BC, as manufactured by:
  1. Ansul Inc., Marinette, WI.
  2. Or approved equal.
- B. Carbon Dioxide (CO<sub>2</sub>) fire extinguishers shall be 10 lb. capacity, portable carbon dioxide type with wall mounts, having Underwriters' Laboratories rating of 10-B, as manufactured by:
  1. Ansul Inc., Marinette, WI.
  2. Or approved equal.
- C. Except where indicated to be mounted within cabinets, provide the manufacturer's standard wall-mounting bracket for each fire extinguisher.
- D. Cabinet: Surfaced mounted or recessed cabinets as indicated on the Contract Drawings. All cabinets shall be #4 finish type 316 stainless steel and 1/8-inch thick DSA glass Size cabinets for extinguishers. Cabinets shall be style "DV" as manufactured by:
  1. Potter-Roemer Inc., Union, NJ.
  2. Or approved equal.

## GENERAL SPECIFICATION 10521 – FIRE EXTINGUISHERS

---

### PART 3 EXECUTION

#### 3.01 INSTALLATION

- A. Fire extinguishers shall be installed where shown on the Contract Drawings and as directed by the Engineer.
- B. Wall mounts for extinguishers shall be securely mounted to masonry with lag bolts and shields.

END OF SECTION

NO TEXT ON THIS PAGE



**GENERAL SPECIFICATION 10801 - TOILET AND BATH  
ACCESSORIES**

---

**SECTION 10801  
Toilet and Bath Accessories**

**PART 1 GENERAL**

**1.01 SECTION INCLUDES**

- A. Toilet and bath accessory work includes, but is not limited to furnishing and installing wall mirrors, paper towel dispensers, waste receptacles, toilet tissue dispensers, grab bars, soap dispensers, and feminine napkin vendor and disposal units. Extent of each type of toilet accessory is shown on the Contract Drawings and schedules.
- B. The following index of this Section is included for convenience:

<u>Article</u>	<u>Title</u>	<u>Page</u>
		10801-
PART 1	GENERAL .....	1
1.01	Section Includes .....	1
1.02	Payment.....	1
1.03	Quality Assurance.....	1
1.04	Submittals .....	2
PART 2	PRODUCTS.....	2
2.01	Manufacturers .....	2
2.02	Toilet Accessories.....	2
PART 3	EXECUTION.....	3
3.01	Inspection.....	3
3.02	Installation.....	3
3.03	Adjust And Clean.....	3

**1.02 PAYMENT**

- A. Payment for all Work required under this Section will be made as provided for in the Detailed Specifications.

**1.03 QUALITY ASSURANCE**

- A. Inserts and anchoring devices shall be set in concrete or built into masonry.
- B. Accessory locations shall be coordinated with other work to avoid interference and to assure proper operation of the accessory units.

**GENERAL SPECIFICATION 10801 - TOILET AND BATH  
ACCESSORIES**

---

1.04 SUBMITTALS

- A. Contractor shall submit technical data and installation instructions for each type of toilet accessory for approval of the Engineer.

PART 2 PRODUCTS

2.01 MANUFACTURERS

1. Products shall be as manufactured by:
  - a. American Specialties, Inc., Yonkers, NY.
  - b. Bobrick Washroom Equipment, Inc., North Hollywood, CA.
  - c. Bradley Corp., Menomonee Falls, WI.
  - d. Watrous, Inc., Pickering, ON, Canada.
  - e. Or approved equal

2.02 TOILET ACCESSORIES

- A. The Contractor shall provide the following toilet accessories from The Bradley Corp. or approved equal, from other manufacturers as specified:
- B. Multi-purpose Unit: Model No. 133. Recessed unit complete with mirror, shelf and soap dispenser. Unit shall be stainless steel type 304 (18-8) satin finish.
- C. Waste Receptacle: Model No. 2017-10. Semi-recessed unit, with hinged cover and push flap door. Unit shall be stainless steel type 304 (18-8) 22 Ga. satin finish. Unit shall come complete with heavy duty vinyl liner.
- D. Napkin/Tampon Dispenser and Disposal: Model No. 403 recessed unit with stainless steel waste receptacle and push flap door. Unit shall be stainless steel type 304 (18-8) satin finish.
- E. Toilet Tissue Dispenser: Model No. 5402. Surface mounted dual roll unit with theft resistant device. Unit shall be stainless steel type 304, satin finish.
- F. Grab Bars: Model No. 817-2. Provide 12-inch O.D. exposed mounting, heavy duty stainless steel with sanitary safety grip. Units shall be 3'-6" long or as indicated otherwise on the Contract Drawings.
- G. Soap Dish (for showers): Model No. 900-59. Provide surface mounted, stainless steel type 304 (18-8) 7 Ga. with satin finish.
- H. Robe Hook: Model No. 9118-81. Provide exposed mounting heavy duty hooks, three (3) for each shower.

**GENERAL SPECIFICATION 10801 - TOILET AND BATH  
ACCESSORIES**

---

- I. Shower curtain, rod and hooks: Model Nos. 953, 9537, 9536. Provide exposed mounting stainless steel type 304 (18-8) 20 Ga. shower rods. Curtains shall be nylon reinforced antibacterial vinyl fabric (white). Provide stainless steel spring wire curtain hooks with snap fasteners.
- J. Utility Shelf: Model No. 758. Shall be 8-inches wide x 24-inches long stainless steel type 304 (18-8) 18 Ga. with satin finish.
- K. Seat Cover Dispenser: Model No. 583. Shall be surface mounted stainless steel type 304 22 Ga. with satin finish.
- L. Electric Hand Dryer: Model No. 2877-28. Surface mounted with chrome plated cover. Motor shall be 1/10 HP, 120 volt, 17 amp 60 Hz, with a no lubrication required, feature.

**PART 3 EXECUTION**

**3.01 INSPECTION**

- A. Installer shall examine substrates, previously installed inserts and anchorages necessary for mounting of toilet accessories and other conditions under which installation is to occur, and shall notify the Contractor of conditions detrimental to proper completion of work. Work shall not proceed until unsatisfactory conditions have been corrected in a manner acceptable to the Engineer.

**3.02 INSTALLATION**

- A. Toilet accessory units shall be installed in accordance with manufacturer's instructions, use fasteners which are appropriate to substrate and recommended by the manufacturer of the unit. Units shall be installed plumb and level, firmly anchored in locations indicated.
- B. Install mirrors with back frame concealed fasteners.

**3.03 ADJUST AND CLEAN**

- A. Toilet accessories shall be adjusted for proper operation so that mechanisms function smoothly.
- B. All exposed surfaces shall be cleaned and polished after removing protective coating.

**END OF SECTION**

**GENERAL SPECIFICATION 10801 - TOILET AND BATH ACCESSORIES**

---

NO TEXT ON THIS PAGE

**SECTION 12305  
Storage Equipment**

**PART 1 GENERAL**

**1.01 SECTION INCLUDES**

- A. Storage equipment as specified herein shall include, but not be limited to, storage shelving units, storage cabinets, pallet racks, and appurtenances.
- B. Storage equipment items shall be provided where shown on the Contract Drawings, specified in the Detailed Specifications, or as required for a complete installation.
- C. The following index of this Section is presented for convenience:

<u>Article</u>	<u>Title</u>	<u>Page</u>
		12305-
PART 1	GENERAL .....	1
1.01	Section Includes .....	1
1.02	Payment.....	1
1.03	Quality Assurance.....	2
1.04	Environmental Conditions .....	2
1.05	Submittals .....	2
1.06	Performance Requirements.....	2
1.07	Delivery, Storage And Handling.....	3
PART 2	PRODUCTS.....	4
2.01	Manufacturers .....	4
2.02	Materials .....	4
PART 3	EXECUTION.....	5
3.01	Examination .....	5
3.02	Installation.....	5
3.03	Protection .....	5
3.04	Adjustment.....	6
3.05	Cleaning.....	6

**1.02 PAYMENT**

- A. No direct payment will be made for storage equipment, accessories, or appurtenances; the cost shall be included in the prices for the Work, except as provided for in the Detailed Specifications.

## GENERAL SPECIFICATION 12305 – STORAGE EQUIPMENT

### 1.03 QUALITY ASSURANCE

- A. Storage equipment shall be manufactured by a company specializing in fabricating the products specified in this Section with a minimum of five years documented experience.

### 1.04 ENVIRONMENTAL CONDITIONS

- A. The building shall be enclosed, and the ambient temperature of the area in which the work occurs shall be maintained between 60 degrees F and 90 degrees F during and after installation. Relative humidity shall not exceed 80 percent.

### 1.05 SUBMITTALS

- A. The Contractor shall submit Shop Drawings for approval of the Engineer. Submittals shall include, but not be limited to:
1. Catalog cuts and reference materials.
  2. Design Drawings.
  3. Product assembly and installation details.
- B. Product Data: The Contractor shall submit copies of specifications, installation instructions and general recommendations from the storage equipment manufacturer. Manufacturer's data substantiating that the materials comply with the requirements shall be included.

### 1.06 PERFORMANCE REQUIREMENTS

- A. Closed End Storage Shelf Capacities: Each shelf shall have an evenly distributed load carrying capacity as follows:

<b>Shelf Width</b>	<b>Shelf Depth</b>	<b>Capacity (pounds)</b>
36"	12"	800
36"	18"	800
36"	24"	800
48"	12"	400
48"	18"	450
48"	24"	500

- B. Open End Storage Shelf Capacities: Each shelf shall have an evenly distributed load carrying capacity as follows:

**GENERAL SPECIFICATION 12305 – STORAGE EQUIPMENT**

---

<b>Shelf Width</b>	<b>Shelf Depth</b>	<b>Capacity (pounds)</b>
36"	18"	350
36"	24"	350
36"	36"	350
48"	18"	250
48"	24"	250
48"	36"	250

C. Pallet Racks:

Each pallet rack frame shall have a total load carrying capacity of 30,000 pounds.

Each pair of pallet rack beams shall have a total load carrying capacity as follows:

<b>Beam Span</b>	<b>Capacity (pounds)</b>	<b>Maximum Deflection</b>
96"	8282	0.348"
108"	6266	0.521"
120"	6595	0.554"
144"	8395	0.720"

1.07 DELIVERY, STORAGE AND HANDLING

A. Delivery of Materials:

Materials shall not be delivered to the project site before the time of installation.

Materials shall be delivered in sufficient quantities to allow continuity of the Work.

B. Storage of Materials:

Materials shall be stored in original, undamaged containers with manufacturer's labels and seals intact.

All materials shall be stored in a dry, enclosed area, off the ground and away from all possible contact with water, ice or snow.

Damage to materials during storage shall be prevented primarily by minimizing the amount of time they are stored at the project site before being incorporated into the Work.

C. Handling of Materials:

Materials shall be handled carefully in order to avoid damage or breakage.

Materials shall not be exposed to detrimental conditions or physical damage. Materials which are so exposed shall be removed from the site and shall not be incorporated into the Work.

Materials shall be handled in such a manner so as to prevent inclusion of foreign materials.

Packages or containers shall not be opened until all necessary preparatory Work is complete and installation is to begin immediately. Materials shall not be allowed to become wet or soiled or covered with ice or snow.

PART 2 PRODUCTS

2.01 MANUFACTURERS

A. Manufacturers shall be as listed in the Detailed Specifications.

2.02 MATERIALS

A. Open end shelving units shall be constructed using the following materials:

Posts shall be punched for clip or nut and bolt construction, and shall be such that all shelves and accessories shall be vertically adjustable on 1-inch centers.

Side panels shall be of 24 gauge steel and shall be punched with holes for bolting to posts.

Backs: Backs shall be of 24 gauge steel with holes on each side for bolting to posts and in the middle for using a back panel clip.

Shelves shall be manufactured from cold rolled steel with a 1-1/4-inch face on all four sides. Front and rear faces shall have four 90 degree bends to provide a 3/4-inch by 1-1/4-inch tubular shape which shall be spot welded to the underside of the shelf on 3-inch centers.

B. Closed end shelving units shall be constructed using 1-7/8-inch by 1-7/8-inch angle posts at corners and 3-3/4-inch by 1-7/8-inch tee posts as



intermediates. All shelves shall be vertically adjustable on 1-1/2-inch centers.

- C. Pallet racks shall be a purpose designed engineered system for the storage of palletized items. Frame uprights shall be of MIG welded construction, and each post shall be furnished with a foot plate providing a minimum of 13.7 square inches of load distribution. Beam heights shall be vertically adjustable on 3-inch centers. Pallet racks shall be furnished with frame protectors at each frame upright, rigid wall brackets, and rigid row spacers.
- D. Storage cabinets shall be provided with a minimum of four full width shelves, vertically adjustable in 2-inch increments. Cabinets shall be furnished with a built-in lock with two keys, three hinges per door, and three point latching.
- E. Sizes of storage equipment shall be as specified in the Detailed Specifications.
- F. Finish: Storage equipment shall be furnished with the manufacturer's standard baked enamel finish in a color as selected by the Engineer from the manufacturer's full range of standard colors.

**PART 3 EXECUTION**

**3.01 EXAMINATION**

- A. The Contractor shall verify that areas to receive storage equipment are properly prepared and completed to final elevations.

**3.02 INSTALLATION**

- A. Storage equipment shall be installed in accordance with the manufacturer's instructions and approved Shop Drawings. All pallet rack vertical frames shall be anchored to floor slabs in accordance with the manufacturer's recommendations.

**3.03 PROTECTION**

- A. All components of the Work shall be protected from detrimental weather and damage until construction operations are completed and acceptable to Engineer.
- B. Storage equipment shall be protected from all damage and abuse from all other Contractors and installers involved in the Work until Final Acceptance by the City. All surfaces shall be protected from abrasion or the adherence of any foreign material by maintaining covers when necessary.

## GENERAL SPECIFICATION 12305 – STORAGE EQUIPMENT

---

### 3.04 ADJUSTMENT

- A. System components which are dislodged, damaged, expanded, broken, penetrated or crushed by subsequent installation operations or damaged by detrimental weather shall be immediately replaced with undamaged material in compliance with the Sections and properly protected as specified.

### 3.05 CLEANING

- A. After installation, storage equipment shall be cleaned and left in a neat condition. Units shall be cleaned using materials and processes as recommended by the manufacturer.

END OF SECTION

**GENERAL SPECIFICATION 13101 - LIGHTNING PROTECTION SYSTEM**

---

**SECTION 13101  
Lightning Protection System**

**PART 1 GENERAL**

**1.01 SECTION INCLUDES**

- A. Requirements for providing lightning protection. Lightning protection systems shall be provided in accordance with the requirements specified under this Section, the Contract Drawings and the Detailed Specifications.
- B. The following index of this Section is presented for convenience:

<u>Article</u>	<u>Title</u>	<u>Page</u>
		13101-
PART 1	GENERAL.....	1
1.01	Section Includes.....	1
1.02	Payment.....	1
1.03	Related Section.....	1
1.04	References.....	2
1.05	Submittals.....	2
1.06	Quality Assurance.....	3
1.07	Delivery, Storage And Handling.....	3
PART 2	PRODUCTS.....	3
2.01	Manufacturers.....	3
2.02	Components.....	4
2.03	Non-Metallic Conduit And Fittings.....	4
PART 3	EXECUTION.....	4
3.01	Installation.....	4
3.02	Field Inspection.....	6

**1.02 PAYMENT**

- A. Unless otherwise provided in the Detailed Specifications, no separate payment will be made for performing any Work of this Section and the Contractor shall include all costs thereof in its lump sum price bid for the Contract.

**1.03 RELATED SECTION**

- A. General Specification 16061 - Grounding.

**1.04 REFERENCES**

- A. The lightning protection systems shall comply with the latest applicable provisions and recommendations of the following:

## GENERAL SPECIFICATION 13101 - LIGHTNING PROTECTION SYSTEM

---

1. LPI 175 - Standard for the Design-Installation-Inspection of Lightning Protection Systems.
2. NFPA 780 - Standard for the Installation of Lightning Protection Systems
3. NYCEC - New York City Electrical Code.
4. UL 96A - Installation Requirements for Lightning Protection Systems
5. UL 651 - Schedule 40, 80, Type EG and A Rigid PVC Conduit and Fittings.

### 1.05 SUBMITTALS

A. Contractor shall submit Shop Drawings and material specifications for the approval of the Engineer. Submittals shall include, but not be limited to:

1. List of proposed manufacturers with the products they produce for the Contract.
2. Manufacturer's catalog cuts and technical information for the lightning protection materials proposed for use.
3. Qualifications of proposed lightning protection contractor.
4. Submit experience records at least 45 days in advance to equipment submittals.
5. Five recent references with phone numbers shall be submitted
6. Scaled Shop Drawings showing proposed routing and layout of the lightning protection system with installation details. Drawings shall include the stamp of the LPI Certified Master Installer- Designer responsible for the system design.
7. Photographic documentation show how the lightning protection systems were installed in-ground and concealed portions of the installation.

B. Certificates of Compliance:

1. Certificates of LPI code compliance, together with UL Master Label Certificate or Letter of Finding.

### 1.06 QUALITY ASSURANCE

A. The Contractor shall retain the services of a lightning protection contractor who is regularly engaged in installing Master Labeled lightning protection systems. The lightning protection Contractor shall be a LPI Certified Master Installer Provide proof of the certification, or

## GENERAL SPECIFICATION 13101 - LIGHTNING PROTECTION SYSTEM

---

demonstrate that the standards and experience required for certification are possessed, all to the satisfaction of the Engineer.

- B. All materials used in the installation shall be labeled or listed by UL for use in Master Labeled lightning protection systems. The completed system shall be in accordance with NFPA 780, LPI 175 and UL 96A.
- C. All materials shall be of stainless steel, copper and high copper- content bronze castings. In locations where system components are mounted on aluminum surfaces, aluminum materials shall be used to avoid electrolytic corrosion of the dissimilar metals.
- D. Materials shall be sized in accordance with the material requirements of NFPA-780, UL96A and LPI 175. Materials shall comply in weight, size and composition for the class of structure to be protected. Class I materials shall be used for systems on structures not exceeding 75 feet in height and Class II materials shall be used for systems on structures exceeding 75 feet above grade.
- E. A UL listed Master Label certification shall be provided for the completed lightning protection system. For installation areas, where a Master Label is not available, a Letter of Finding shall be obtained.

### 1.07 DELIVERY, STORAGE AND HANDLING

- A. Lightning protection system materials shall be delivered, stored and handled in accordance with the Detailed Specifications.

## PART 2 PRODUCTS

### 2.01 MANUFACTURERS

- A. The lightning protection system shall be as manufactured by:
  - 1. Heary Brothers Lightning Protection Company, Springville, NY.
  - 2. Thompson Lightning Protection Company, West St Paul, MN.
  - 3. East Coast Lightning Equipment, Winsted, CT.
  - 4. Pentair Erico, Solon, Ohio
  - 5. Or approved equal.

### 2.02 COMPONENTS

- A. All lightning protection system fittings shall be heavy duty type. All bolts, screws and hardware shall be stainless steel.
- B. Ground rods shall conform to the requirements of General Specification 16061 - Grounding.
- C. Ground Cables:

## GENERAL SPECIFICATION 13101 - LIGHTNING PROTECTION SYSTEM

---

1. Ground cables shall be copper or aluminum where necessary to prevent dissimilar metal reaction.
  2. Ground cable stranding, number and size shall be suitable for the classification of the structure to be protected. All ground cable where exposed shall be corrosion resistant.
- D. Air terminals shall be stainless steel 5/8 inch diameter, eighteen inches long. Air terminals shall include a cast bronze point protector, stainless steel adapter and copper base.
- 2.03 NON-METALLIC CONDUIT AND FITTINGS
- A. Non-metallic conduit shall be schedule 80 PVC plastic, 90 degrees C rated, conforming to UL No. 651.
  - B. Non-metallic fittings shall be of same material and manufacturer as base conduit. Cement shall be provided for joining fittings to the conduit and shall be the same manufacturer as the base conduit.
  - C. Non-metallic conduit and fittings shall be by as manufactured by:
    1. Carlon (Thomas & Betts) - Memphis, TN.
    2. Cantex Inc., Fort Worth, Texas
    3. Or approved equal.

### PART 3 EXECUTION

#### 3.01 INSTALLATION

- A. Main conductors shall be installed to provide a two-way path from each air terminal horizontally or downward to connections with ground terminals.
- B. Conductors shall be installed free of excessive splices and sharp bends. Conductor bends shall form an included angle of not less than 90 degrees nor have a radius of bend of less than 8 inches. Conductors shall be secured to the structure at intervals not exceeding 3 feet.
- C. Down conductors where possible shall be concealed in the exterior wall construction. Down conductors shall be spaced at intervals averaging not more than 100 feet around the perimeter of the structure. In no case shall a structure have fewer than two down conductors.
- D. In the case of structural steel frame construction, down conductors may be omitted and roof conductors shall be connected to the structural steel frame at intervals averaging not more than 100 feet around the perimeter of the structure. Connections to the steel frame shall be made with bonding plates having 8 square inches of contact or by exothermic weld connections.

## GENERAL SPECIFICATION 13101 - LIGHTNING PROTECTION SYSTEM

---

- E. Air terminals shall project a minimum of 10 inches above the area protected and shall be located at intervals not exceeding 20 feet along ridges and around the perimeter of flat or gently sloping roofs.
- F. Air terminals shall be located within 2 feet of roof edges and outside corners of protected areas. Air terminal spacing exceeding these dimensions, shall be permitted so long as the area protected lies within a zone of protection.
- G. Air terminals shall be installed for stacks, flues, mechanical equipment, and other objects, having a metal thickness of less than 3/16 of an inch, and not located within a zone of protection. Objects having a metal thickness 3/16 of an inch or greater shall be connected to the lightning protection system.
- H. Flat or gently sloping roofs exceeding 50 feet in width, shall be protected with additional air terminals located at intervals not exceeding 50 feet in the flat or gently sloping area.
- I. Roof penetrations shall be installed using thru-roof assemblies with solid bars and appropriate roof flashing. Conductors shall not pass directly through the roof.
- J. The system shall be installed with common grounding by interconnecting ground mediums entering the building using main size conductors and fittings. Grounded metal bodies shall be bonded to the system using bonding connections and fittings. Ground conductors where installed in conduit, shall be non - metallic type.
- K. Ground electrodes shall be provided for each down conductor. The down conductor shall be connected to the ground rod using an exothermic welded connection. A bronze ground rod clamp having at least 1-1/2 inches of contact between the rod and the conductor, measured parallel to the axis of the rod shall be used at ground test wells.

### 3.02 FIELD INSPECTION

- A. The Contractor shall have the master installer or inspector perform field inspection of the lightning protection system at several stages during the installation in accordance with LPI requirements.
- B. Upon completion of the lightning protection system the Contractor shall arrange for a final inspection of the system. The final inspection shall be performed by the master installer or inspector in accordance with LPI requirements.

END OF SECTION

**GENERAL SPECIFICATION 13101 - LIGHTNING PROTECTION SYSTEM**

---

NO TEXT ON THIS PAGE



**SECTION 13281**  
**Asbestos Management**

PART 1 GENERAL

1.01 SUMMARY

- A. This Section details the requirements for construction and demolition activities affecting Asbestos-Containing Materials (ACM), trace asbestos materials (i.e., Building Materials containing 1% or less of asbestos), and Asbestos-Containing Waste Materials, as shown on the Contract Drawings, specified herein, or required to complete the Work, including all ACM identified and impacted by the Work. All Work under this Section shall be performed using methods, tools, and equipment that have demonstrated effectiveness in preventing asbestos fibers from migrating outside of the Regulated Abatement Work Area and are in compliance with all applicable rules and regulations.
- B. In the absence of analytical testing results for certain materials, the material shall be classified as material containing both asbestos and polychlorinated biphenyls (PCBs) pending the analytical results. The Disturbance, Abatement/Removal, construction/ demolition, and disposal of materials containing both asbestos and PCBs shall be in accordance with the pertinent federal, state, and local regulations. For activities affecting materials and structures coated with PCB-containing bitumastic coatings, refer to Section 02 84 05 - PCB Management for specific training, handling, and disposal requirements that must be implemented by the Contractor in addition to the requirements of this Section.
- C. All Work under this Section shall be performed to minimize the creation of airborne emissions; minimize the quantity of waste generated; protect the health and safety of all personnel and welfare of the public; and avoid adverse environmental impacts.
- D. Unless otherwise specified, the Work of this Section shall also be performed in accordance with the most current New York City Department of Environmental Protection (DEP) Environmental Health and Safety (EHS) Policies and Procedures (including Asbestos Management, and Spill Prevention, Environmental Release Reporting and Investigation), NYCDEP Bureau of Engineering Design and Construction EHS Standards, and applicable federal, state, and local regulations. It should be noted that DEP Asbestos Projects being conducted on New York City property that is physically located outside of the five boroughs, would be subject to the requirements of 12 NYCRR 56, and not the requirements of RCNY Title 15, Chapter 1.
- E. All independent third party air monitoring shall be outside this Contract and performed by others.

**GENERAL SPECIFICATION 13281 -- ASBESTOS MANAGEMENT**

---

- F. The Contractor shall perform all Work under this Section without damaging or contaminating non-regulated areas. Where such areas are damaged or contaminated, as determined by the DEP, the Contractor shall restore the areas to their original condition at no additional cost to the City.
- G. The Contractor shall label all known ACM in the field to prevent accidental disturbance by workers.
- H. The following index of this Section is presented for convenience.:

<u>Article</u>	<u>Title</u>	<u>Page</u>
		13281-
PART 1	GENERAL.....	1
1.01	Summary.....	1
1.02	Payment.....	2
1.03	Related Sections.....	3
1.04	Reference Standards.....	3
1.05	Definitions.....	6
1.06	Description.....	13
1.07	Quality Assurance.....	14
1.08	Submittals.....	15
PART 2	PRODUCTS.....	25
2.01	Materials.....	25
PART 3	EXECUTION.....	25
3.01	Safe Work Practices For Trace Asbestos Materials.....	25
3.02	Preparation.....	26
3.03	Air Monitoring.....	27
3.04	Bulk Removal.....	28
3.05	Cleanup and Disposal.....	28

1.02 PAYMENT

- A. Except for abatement of unforeseen ACM and related Work payable under the allowance, as described in Section 01355 – Hazardous Materials Control, no separate payment will be made for performing any Work required under this Section and the Contractor shall include all costs thereof in prices bid for the Contract.
- B. At the completion of abatement activities, the Contractor is responsible for submitting all of the documentation required herein. Payment to abate and dispose of ACM and resulting Asbestos-Containing Waste Materials produced by this Work will not be made until all required documentation, including the following is provided to the City:
  - 1. Copies of all NYSDOL and DEP Asbestos Control Program (ACP)-approved Asbestos Project notifications, work permits, Variances,

Work Place Safety Plans, and any applicable documentation filed or received from the NYSDOL and DEP ACP, including Notices of Violations (NOV).

2. Copies of the Asbestos Abatement Contractor's Handling license.
3. Copies of DEP and NYSDOL Asbestos Handler Supervisor and Asbestos Handler certificates, where applicable, for all workers engaged in the project.
4. A copy of the Asbestos Abatement Contractor's daily Isolation Barrier book (bound notebook). Copies of laboratory reports and Chain-of-Custody (COC) documents for Exposure Monitoring conducted by the Asbestos Abatement Contractor, including the name, address, and New York State Department of Health (NYSDOH) Environmental Laboratory Approval Program (ELAP) registration number of the laboratory used for air sample analysis (10 NYCRR 55-2).
5. All data related to bulk sampling, including the results of any asbestos surveys performed by a DEP-certified Asbestos Investigator and NYSDOL-certified Asbestos Inspector, where applicable.
6. The Asbestos Work Plan submitted and implemented in accordance with the requirements of this Section.
7. The total quantity of ACM abated.
8. The start and completion dates of the Asbestos Project(s).
9. A signed copy of the manifest from the asbestos-permitted landfill with complete COC documentation, certifying the amount of asbestos waste delivered;
10. The name and address of the asbestos waste transporter.

1.03 RELATED SECTIONS

- |    |                              |   |  |
|----|------------------------------|---|--|
| A. | Detailed Specification 01355 | - | Hazardous Materials Control                  |
| B. | Detailed Specification 01356 | - | Environmental Health and Safety Requirements |
| C. | Detailed Specification 13284 | - | PCBs Management                              |

1.04 REFERENCE STANDARDS

- A. The Contractor shall comply with all applicable regulations, standards, and guidelines of federal, state, and local environmental and occupational safety and health agencies regarding ACM, trace asbestos materials, and Asbestos-Containing Waste Materials. These regulations, standards, and guidelines include, but are not limited to the following:
  1. ASTM International:

- a. D2898 – Standard Practice for Accelerated Weathering of Fire-Retardant-Treated Wood for Fire Testing;
  - b. E84 – Standard Test Method for Surface Burning Characteristics of Building Materials;
  - c. E1368 – Standard Practice for Visual Inspection of Asbestos Abatement Projects.
2. United States (U.S.) Department of Transportation (DOT):
    - a. 49 CFR 171 - General Information, Regulations, and Definitions;
    - b. 49 CFR 172 – Hazardous Materials Table, Special Provisions, Hazardous Materials Communications, Emergency Response information, and Training Requirements;
    - c. 49 CFR 173 – Shippers: General Requirements for Shipments and Packagings;
    - d. 49 CFR 178 – Specifications for Packagings.
3. United States Environmental Protection Agency (EPA):
    - a. 40 CFR 61 - National Emission Standards for Hazardous Air Pollutants (NESHAP);
    - b. 40 CFR 262 - Standards Applicable to Generators of Hazardous Waste;
    - c. 40 CFR 268 – Land Disposal Restrictions;
    - d. 40 CFR 302 – Designation, Reportable Quantities, and Notification;
    - e. 40 CFR 763 - Asbestos Hazard Emergency Response Act (AHERA).
4. National Institute for Occupational Safety and Health (NIOSH):
    - a. Method 7400 – Asbestos and Other Fibers by PCM;
    - b. Method 7401 – Asbestos by TEM.
5. National Fire Protection Association (NFPA):
    - a. NFPA 255, Standard Method of Test of Surface Burning Characteristics of Building Materials;
    - b. NFPA 701, Standard Methods of Fire Tests for Flame Propagation of Textiles and Films.
6. City Department of Environmental Protection (DEP):

## GENERAL SPECIFICATION 13281 -- ASBESTOS MANAGEMENT

---

- a. Environmental Health and Safety Policies and Procedures – Vol. II, Spill Prevention, Environmental Release Reporting and Investigation;
  - b. Environmental Health and Safety Policies and Procedures – Vol. III, Asbestos Management;
  - c. Environmental Health and Safety Policies and Procedures – Vol. IV, PCB Management;
  - d. RCNY Title 15 Chapter 1 - Asbestos Control Program Rules and Regulations;
  - e. RCNY Title 15 Chapter 19 – Discharges of Wastewater and Other Materials to Public Sewers.
7. New York City Department of Sanitation (DSNY):
- a. RCNY Title 16 Chapter 8 – Asbestos Rules and Regulations.
8. New York State Department of Environmental Conservation (NYSDEC):
- a. 6 NYCRR 360 - Solid Waste Management Facilities;
  - b. 6 NYCRR 364 - Waste Transporter Permits;
  - c. 6 NYCRR 376 – Land Disposal Restrictions.
9. New York State Department of Health (NYSDOH):
- a. 10 NYCRR 55-2 – Approval of Laboratories Performing Environmental Analysis.
10. New York State Department of Labor (NYSDOL):
- a. 12 NYCRR 56 - Asbestos Rules and Regulations.
11. Occupational Safety and Health Administration (OSHA):
- a. 29 CFR 1910 – Occupational Safety and Health Standards;
  - b. 29 CFR 1910.28 – Safety Requirements for Scaffolding;
  - c. 29 CFR 1926.65 – Hazardous Waste Operations and Emergency Response;
  - d. 29 CFR 1910.134 - Respiratory Protection Standard;
  - e. 29 CFR 1910.1001 - Asbestos Standard for General Industry;
  - f. 29 CFR 1910.1200 - Hazard Communication Standard;
  - g. 29 CFR 1926 - Safety and Health Regulations for Construction;
  - h. 29 CFR 1926.1101 - Asbestos Standard for the Construction Industry.

12. Underwriters Laboratories, Inc. (UL):
  - a. UL 586 – Standard for Safety High Efficiency, Particulate, Air Filter Units.
  - b. UL 723 – Standard for Test for Surface Burning Characteristics of Building Materials.

1.05 DEFINITIONS

- A. Abatement: Any and all procedures physically taken to control fiber releases from ACM. This includes Removal, Encapsulation, enclosure, cleanup, and Repair.
- B. Adequately Wet: Defined by the EPA (40 CFR 61.141) as a material sufficiently mixed or penetrated with amended water to prevent the release of Visible Emissions. If Visible Emissions are observed coming from an ACM or asbestos waste, then the material has not been “Adequately Wetted.” However, the absence of Visible Emissions is not evidence of being Adequately Wet. ACM must be fully penetrated with the wetting agent to be Adequately Wet. If the ACM being abated is resistant to amended water penetration, the wetting agent shall be applied to the material prior to and during Abatement as necessary to minimize the potential for fiber releases.
- C. Aggressive Air Sampling: A method of sampling within a Negative Pressurized Enclosure (NPE) in which mechanical equipment is used before and during the sampling period to stir up settled dust/asbestos fibers. Mechanical equipment includes 20-inch fans and forced air equipment (e.g., a one-horsepower leaf blower).
- D. Air Sampling Technician: A person who performs Asbestos Project air sampling and possesses a valid Air Sampling Technician certificate issued by the NYSDOL.
- E. Ambient Air Monitoring: The measurement or determination of airborne asbestos fiber concentrations outside but in the general vicinity of the Work site, performed in accordance with NIOSH or EPA sampling methodologies.
- F. Asbestos Abatement Contractor: A Subcontractor licensed by the NYSDOL who performs Abatement during an Asbestos Project, or employs persons performing such Abatement.
- G. Asbestos Abatement Permit: A permit issued by the DEP ACP in accordance with RCNY Title 15, Chapter 1, authorizing the performance of construction Work for Asbestos Projects involving any of the activities defined in RCNY Title 15, Chapter 1-26(a) (1)-(13).
- H. Asbestos Assessment Report (Form ACP-5): A form submitted to the DEP ACP by which a DEP-certified Asbestos Investigator certifies that a building or

structure (or portion thereof) is free of ACM or the amount of ACM to be abated constitutes a Minor Asbestos Project.

- I. ACM: Any material containing greater than one percent asbestos.
- J. Asbestos Handler: An individual certified by the DEP and/or NYSDOL who disturbs, removes, encapsulates, repairs, or encloses ACM. Asbestos Handlers working on projects within the five boroughs shall possess both DEP and NYSDOL certifications. Asbestos Handlers working on projects outside of the five boroughs shall possess NYSDOL certifications.
- K. Asbestos Handler Supervisor: An individual certified by the DEP and/or NYSDOL who supervises the asbestos handlers during an Asbestos Project, and ensures that proper asbestos Abatement procedures as well as individual safety procedures are being adhered to. Asbestos Handler Supervisors working on projects within the five boroughs shall possess both DEP and NYSDOL certifications. Asbestos Handler Supervisors working on projects outside of the five boroughs shall possess NYSDOL certifications.
- L. Asbestos Project: Any Work performed in connection with the alteration, renovation, modification, or demolition of a building or structure, or in connection with the replacement or repair of equipment, pipes, or electrical equipment not located in a building or structure, which will involve the Abatement, Disturbance, or cleanup of friable or Non-Friable Asbestos. Asbestos Projects are classified as either Large Asbestos Projects, Small Asbestos Projects, or Minor Asbestos Projects in New York State and New York City, and each type of project involves several phases, which can include: background air monitoring, mobilization, pre-abatement/Containment construction, Abatement, cleaning/re-cleaning, final Clearance Air Monitoring, Containment breakdown, and demobilization.
- M. Asbestos Project Notification (Form ACP-7): A form submitted to the DEP ACP for all Large Asbestos Projects and Small Asbestos Projects. Minor Asbestos Projects do not require an ACP-7 form.
- N. Asbestos-Containing Waste Material: ACM or asbestos-contaminated objects requiring disposal.
- O. Building Materials: Any and all materials listed in 12 NYCRR 56-5.1(f)(1), including but not limited to interior and exterior finished, equipment, plaster, roofing, flooring, caulking, sealants, tiles, insulation, and mortar and refractory bricks used in the construction of boilers.
- P. Clean Room: An uncontaminated area or room that is part of the Personal Decontamination Enclosure System, with provisions for the storage and changing of “street clothes” into clean Personal Protective Equipment (PPE).
- Q. Clearance Air Monitoring: Area air monitoring performed inside the Restricted Area and Regulated Abatement Work Area after the completion of the final

- cleaning, final waiting period, and Final Visual Inspection by the Asbestos Handler Supervisor and Project Monitor. Aggressive Air Sampling shall be performed as part of the Clearance Air Monitoring activities inside of the Containment.
- R. Containment: The NPE within the Restricted Area, which establishes the Regulated Abatement Work Area, and surrounds the location where the asbestos Abatement is actually taking place.
- S. Critical Barrier: A term used by the NYS DOL to define barriers that seal-off all openings to or within the defined Regulated Abatement Work Area, including but not limited to operable windows, skylights, doorways, ducts, grills, diffusers, and any other penetrations to surfaces adjacent to or within the Regulated Abatement Work Area.
- T. Disturbance: Any activities that disrupt the matrix of ACM, or Asbestos-Containing Waste Materials. This includes activities that generate dust, debris, Visible Emissions, or airborne asbestos fibers, including moving friable ACM or Asbestos-Containing Waste Materials from one place to another.
- U. Encapsulation: The coating or spraying of ACM, or the bare substrate surface that is exposed after an Abatement, with a pigmented (i.e., non-transparent) liquid sealant that creates a membrane over the surface of the material (bridging encapsulant) or penetrates into the material and binds its components together (penetrating encapsulant).
- V. Excursion Limit: Defined in the OSHA Asbestos Standard for the Construction Industry (29 CFR 1926.1101) as individual exposure, without regard to the use of respirators, to an airborne concentration of asbestos fibers of 1.0 fiber per cubic centimeter of air (1.0 f/cc) averaged over a 30-minute sampling period. No employee of the Contractor shall at any time be exposed to concentrations of asbestos fibers above the Excursion Limit.
- W. Exposure Monitoring: Personal air sampling performed outside the respirator within the breathing zone of individuals that are representative of the 8-hour TWA and 30-minute short-term exposures of each employee, for the purpose of determining compliance with OSHA's Asbestos Standard for the Construction Industry (29 CFR 1926.1101). Analytical results from Exposure Monitoring will be used to select appropriate respiratory protection and PPE for individuals within a Restricted Area and Regulated Asbestos Work Area. For the purpose of this Section, Exposure Monitoring samples shall be collected from individuals who are representative of each task being conducted by the Contractor, and all Exposure Monitoring shall follow pertinent NIOSH or EPA sampling methodologies.
- X. Final Visual Inspection: An inspection performed by the Project Monitor and Asbestos Handler Supervisor at the completion of the final waiting period on an Asbestos Project (but prior to Clearance Air Monitoring). The inspection is



performed in accordance with ASTM E1368 to determine the completeness of Abatement and cleanup.

- Y. Friable Asbestos: A term used by the NYSDOL to define any ACM or asbestos waste that can be crumbled, pulverized or reduced to powder when dry, by hand pressure.
- Z. Glovebag: A manufactured, impervious, bag-like enclosure with two (2) inward-projecting long sleeve gloves, one (2) inward-projecting waterwand sleeve, an internal tool pouch, and an attached, labeled receptacle for asbestos waste. The Glovebag is constructed and installed to surround an object or area to be abated, and contain all asbestos fibers released during the Abatement process.
- AA. High-Efficiency Particulate Air (HEPA) Filter: A filter designed to remove 99.97% of all particles greater than 0.3 micrometers ( $\mu\text{m}$ ) in diameter. For the purpose of this Section, HEPA vacuum and Negative Air Pressure Equipment (i.e., Microtraps) used by the Contractor shall meet the Standard for Safety High-Efficiency, Particulate, Air Filter Units (UL 586) developed by Underwriters Laboratories.
- BB. Holding Area: A room or area in the Waste Decontamination Enclosure System utilized for the temporary (i.e., no longer than the current work shift) storage of containerized asbestos waste, prior to its transfer to a final on-site storage container (i.e., dumpster, trailer, or roll-off) or a licensed asbestos waste transport vehicle. The Holding Area is located between the washroom and an uncontaminated area.
- CC. Independent Third Party Monitor: A NYSDOL-licensed asbestos contractor who will be contracted by the Engineer or the City, and is completely independent of the Asbestos Abatement Contractor involved with the Asbestos Project. The independent third party who conducts ambient and clearance air monitoring or Project Monitoring on an Asbestos Project shall not have any business, personal, or other relationship with the Asbestos Abatement Contractor.
- DD. Isolation Barrier: A term used to define the construction of partitions, the placement of solid materials, and the plasticizing of apertures to seal off the Regulated Abatement Work Area from surrounding areas and contain asbestos fibers.
- EE. Large Asbestos Project: An Asbestos Project involving the Removal, enclosure, Encapsulation, Repair, Disturbance, cleanup, or handling of 260 linear feet or more of ACM, or 160 square feet or more of ACM.
- FF. Log: An official record, maintained by the Asbestos Abatement Contractor, of all activities that occurred during the Asbestos Project. The Log shall be in the form of a bound notebook, and at a minimum, identify the following

- information: (a) the building owner, agent, contractor, and workers; (b) daily activities, cleanings, and waste transfers; (c) the names and certificate numbers of all Asbestos Handlers and Asbestos Handler Supervisors; (d) the results of inspections of decontamination systems, barriers, and negative pressure ventilation equipment; (e) summaries of all corrective actions and Repairs; (f) work stoppages with reasons for stoppages; (g) manometer readings at least twice per work shift; (h) daily checks of emergency and fire exits; (i) any unusual events.
- GG. Microtrap: (See definition of “Negative Air Pressure Equipment”).
- HH. Minor Asbestos Project: An Asbestos Project involving the Removal, enclosure, Encapsulation, Repair, Disturbance, cleanup, or handling of 25 linear feet or less of ACM, or 10 square feet or less of ACM.
- II. Negative Air Pressure Equipment: A local exhaust system capable of maintaining air pressure within the Containment at a lower pressure than the air outside of the Containment. The Negative Air Pressure Equipment also provides for the HEPA filtration of all air exhausted from the Containment.
- JJ. Non-Friable Asbestos: A term used by the NYSDOL to define any ACM or asbestos waste that cannot be crumbled, pulverized or reduced to powder when dry, by hand pressure.
- KK. Obstruction: The blocking of a means of egress with any temporary structure or barrier. Polyethylene sheeting shall not be considered an Obstruction when it is prominently marked with exit signage or paint, and cutting tools (i.e., a knife or razor blade) are attached to the work area side of the sheeting for use in the event that the sheeting must be cut to permit egress. A corridor shall not be considered obstructed when there is a clear path measuring at least three feet wide.
- LL. OSHA Monitoring: (See definition of “Exposure Monitoring”).
- MM. P-100 Filter: (See definition of: “HEPA”).
- NN. Perimeter Monitoring: (See definition of “Area Monitoring”).
- OO. Permissible Exposure Limit (PEL): Defined in the OSHA Asbestos Standard for the Construction Industry (29 CFR 1926.1101) as individual exposure, without regard to the use of respirators, to an airborne concentration of asbestos fibers of 0.1 fibers per cubic centimeter of air (f/cc) calculated as an 8-hour Time-Weighted Average (TWA). No employee of the Contractor shall at any time be exposed to concentrations of asbestos fibers above the PEL. See also Excursion Limit.
- PP. Personal Decontamination Enclosure System: A series of connected rooms designed to control the passage of Asbestos Handlers, and other authorized individuals into the Regulated Abatement Work Area from uncontaminated areas. The system consists of a Clean Room, a Shower Room, and an equipment

room separated from each other and the Regulated Abatement Work Area by airlocks and curtained doorways.

- QQ. Personal Monitoring: (See definition of “Exposure Monitoring”).
- RR. Phase Contrast Microscopy (PCM): An analytical method (e.g., NIOSH 7400 and 7401) used for determining the asbestos fiber concentration in an air sample.
- SS. Polarized Light Microscopy (PLM): An analytical method (e.g., 40 CFR 763, Subpart F, Appendix A or ELAP Item 198.1 or 198.6) used for determining the asbestos content in a bulk material.
- TT. Post Abatement Air Monitoring: (See definition of “Clearance Air Monitoring”).
- UU. Presumed Asbestos-Containing Material (PACM): Material suspected of containing asbestos as described in 15 RCNY 1-38. PACM is considered to be ACM unless proven otherwise by appropriate bulk sampling and laboratory analysis.
- VV. Project Designer: A person who performs Asbestos Project design functions and possesses a valid Project Designer certificate issued by the NYSDOL.
- WW. Project Monitor: A person who performs Asbestos Project Monitoring functions and possesses a valid Project Monitor certificate issued by the NYSDOL.
- XX. Regulated Abatement Work Area: The portion of the Restricted Area where Abatement Work actually occurs. This includes the interior of the Restricted Area Containment enclosure. For Glovebag operations, the areas contiguous to where the operation takes place are Regulated Abatement Work Areas. For tents, the interior of each tent is a Regulated Abatement Work Area. For exterior, Non-Friable Asbestos Abatement conducted without the establishment of negative air ventilation systems or Containment enclosures, the entire Restricted Area surrounding the Abatement location is considered to be the Regulated Abatement Work Area.
- YY. Removal: The stripping of any ACM from surfaces or components of a building or structure.
- ZZ. Repair: A term used by the DEP to define a corrective action using specified work practices (e.g., Glovebags or tents) to minimize potential asbestos fiber releases from minimally damaged ACM.
- AAA. Restricted Area: An area established and marked for the Abatement portion of an Asbestos Project. The area shall include, but not be limited to, Regulated Abatement Work Areas and any contiguous decontamination enclosure systems, adjoining staging areas where work materials, debris, or waste

materials from such Work may accumulate, and waste storage areas (e.g., dumpsters, trailers, or roll-offs).

- BBB. Shower Room: A room between the Clean Room and the equipment room in the Personal Decontamination Enclosure System set up to prevent cross-contamination by ensuring the removal of potential asbestos contamination from the body that may have accumulated during Abatement operations. The Shower Room shall have hot and cold running water controllable at the tap, shall be arranged for complete showering during decontamination, and shall include clean, dry towels, soap, and shampoo in quantities sufficient to accommodate the personnel working on the Asbestos Project.
- CCC. Small Asbestos Project: An Asbestos Project involving the Removal, enclosure, Encapsulation, Repair, Disturbance, cleanup, or handling of more than 25 linear feet but less than 260 linear feet of ACM, or more than 10 square feet but less than 160 square feet of ACM.
- DDD. Suspect ACM: All friable and non-friable materials suspected of containing asbestos as determined by a certified NYSDOL Asbestos Inspector or certified DEP Asbestos Investigator, which have not been sampled and analyzed for asbestos content. Suspect ACM includes PACM.
- EEE. Tent: (See definition of “Containment”).
- FFF. Transmission Electron Microscopy (TEM): An analytical method (e.g., 40 CFR 763, Subpart F, Appendix A or ELAP Item 198.4) used for determining the asbestos fiber concentration in an air sample, or for determining the asbestos content in a bulk material.
- GGG. Trace Asbestos-Containing Material: A building material that contains less than or equal to 1% of asbestos.
- HHH. Variance: Relief from specific requirements set forth in state or local asbestos regulations, which is granted in writing by the agency that enforces the regulations.
- III. Visible Emission: Any emission containing particulate material that can be seen without the aid of instruments.
- JJJ. Waste Decontamination Enclosure System: A series of connected rooms designed to control the transfer of materials and equipment from the Regulated Abatement Work Area. The system consists of a washroom and a Holding Area separated from each other and the Regulated Abatement Work Area by airlocks and curtained doorways.
- KKK. Wet Cleaning: The process of eliminating asbestos contamination from surfaces, equipment, or other objects by using cloths, mops, or other cleaning tools that have been saturated with amended water.

LLL. Worker Decontamination Enclosure System: (See definition of “Personal Decontamination Enclosure System”).

MMM. Work Place Safety Plan: Construction documents prepared by a registered design professional and submitted for review to the DEP ACP in order to obtain an Asbestos Abatement Permit. The plan shall include, but not be limited to, plans, sections, and details of the Regulated Abatement Work Area clearly showing the extent, sequence, and means and methods by which the Work is to be performed.

1.06 DESCRIPTION

A. Commencement of Work: 10 business days prior to the proposed start of Work at each separate location, the Contractor shall notify the Engineer, the onsite safety staff, and building occupants. No Work may proceed at any location until authorized by the Engineer.

B. The Contractor shall coordinate any required equipment shutdowns with the Engineer prior to starting the work.

C. Access Restrictions: The Contractor shall inform the Engineer of proposed access restrictions (i.e., areas or items of equipment which will not be accessible during the proposed Asbestos Project), and provide them estimated time frames (including specific dates) of such proposed access restrictions. The Contractor shall be aware that Other Contractors may be at the Work Site. As a result, the Contractor shall not have exclusive rights to the Work Site, and shall fully cooperate and coordinate the Work with the work of Other Contractors who may be on Site. Therefore, the Contractor shall notify Other Contractors in advance of the abatement Work included herein, to provide them with sufficient time for coordination of interrelated items that are included in their contracts and that must be performed before, after, or in conjunction with the Work included under this Section.

1. The Contractor shall ensure that Personal and Waste Decontamination Enclosure Systems along with the Regulated Abatement Work Area are constructed of solid materials with lockable doors to prevent unauthorized entry during non-working hours.

D. Meetings: The Contractor shall visit and investigate the site and review the Contract Drawings, this Section, DEP EHS Policies and Procedures, and become familiar with any conditions which may affect the Work, as part of the pre-construction meeting and site walk-through. The Contractor shall hold all meetings with appropriate parties as scheduled and as otherwise necessary to accomplish the Work of the Contract in accordance with its specific requirements and standards. In addition to the pre-construction meeting and site walk-through, other meetings may be required or may be requested by the Engineer, including briefings with Site Operations personnel. Written documentation (i.e., “minutes”) of all meetings shall be generated by the

Contractor, and copies shall be provided to DEP within three (3) business days following each meeting.

1.07 QUALITY ASSURANCE

- A. **Permits and Notifications:** The Contractor shall make all necessary notifications, secure any necessary permits and Variances, complete agency-required forms, and pay all fees in conjunction with asbestos Abatement activities, waste transportation, and waste disposal in accordance with federal, state, and local asbestos regulations. Prior to the submittal of any notifications, permit/Variance applications, or forms to regulatory agencies, the Contractor shall provide them to the Engineer for review.
- B. **Scheduling:** The Contractor shall coordinate and schedule all phases of the work to be performed under this Section with the DEP, subcontractors, material suppliers, and other parties as necessary to ensure the proper execution of the Work.
- C. **Compliance:** In addition to the requirements of this Section, DEP EHS Policies and Procedures and Section 01356 – Environmental Health and Safety (EHS) Requirements, the Contractor shall comply with all applicable regulations of federal, state, and local authorities pertaining to the Abatement, Disturbance, cleanup, handling, transportation, storage, and disposal of ACM, trace asbestos materials, and Asbestos-Containing Waste Materials. All matters regarding the interpretation of any regulations, standards, or policies shall be submitted to the Engineer for resolution before starting the Work. Where the requirements of this Section, DEP EHS Policies and Procedures, and federal, state, or local regulations conflict or vary, the most stringent requirements or regulations shall apply.
- D. **Rejection of Non-Complying Items:** DEP reserves the right to reject items incorporated into the Work which fail to meet the specified minimum requirements. DEP also reserves the right to reject Contractor submittal items that it deems inappropriate or unacceptable. Included in the category of non-complying items are proposed vendors, subcontractors or personnel with regulatory citations/violations. The DEP further reserves the right, and without prejudice to other recourse, to accept non-complying items subject to an adjustment in the Contract amount, as approved by the DEP.
- E. **Qualifications:**
- F. **Asbestos Abatement Contractor:** The Contractor shall possess a current NYSDOL asbestos license, and shall have successfully completed at least two (2) Asbestos Projects of comparable scope and methodologies to the Work being performed under this Section within the past three (3) years. This experience shall be documented by identifying the following: (a) the name, address, and phone number of each facility where the work was performed; (b) the name of the individual representing the owner at each facility; (c) the types

of facilities where the work was performed; (d) the volume and type of each material that was abated; (e) the specific methods of Abatement used at each facility (including the tools, technologies, and engineering controls employed);

- G. Asbestos Handler Supervisor: The Contractor shall have on staff and assigned to this Contract an Asbestos Handler Supervisor. The Asbestos Handler Supervisor shall be currently certified by the DEP (if working on Asbestos Projects in the five boroughs) and NYSDOL (for all Asbestos Projects). In addition, the Asbestos Handler Supervisor shall have a minimum of two (2) years' experience on Asbestos Projects, and shall have served as the Asbestos Handler Supervisor on at least three (3) Asbestos Projects of comparable scope and methodologies to the work being performed under this Section.
- H. Asbestos Handler: The Contractor shall have on staff and assigned to this Contract a sufficient number of experienced and properly trained Asbestos Handlers. Asbestos Handlers shall be currently certified by the DEP (if working on Asbestos Projects in the five boroughs) and NYSDOL (for all Asbestos Projects), and shall have a minimum of one (1) year of experience on Asbestos Projects, and shall have worked on at least three (3) Asbestos Projects of comparable scope and methodologies to the Work being performed under this Section.

1.08 SUBMITTALS

- A. Thirty business days prior to commencement of the Work of this Section or as directed by the Engineer, the Contractor shall submit the following to the Engineer:
  - 1. Asbestos Inspection and Sampling Plan: The Contractor shall provide an Asbestos Inspection and Sampling Plan to identify suspect asbestos-containing materials and collect confirmatory samples, as appropriate during the inspection.
  - 2. The Asbestos Inspection and Sampling Plan shall include at a minimum:
    - a. Credentials of the individual responsible for inspection and sampling. At a minimum, the inspection shall be performed by a certified NYSDOL Asbestos Inspector or a certified NYCDEP Asbestos Investigator (if performed within the City), who shall have current HAZWOPER training, OSHA 10-hour certification, and confined space entry training, as applicable to the location or work, and shall have performed similar inspection work on at least three (3) projects of comparable scope.
    - b. Credentials of the laboratory providing sample analysis. The credentials shall include current certification by the NYSDOH ELAP.

- c. Sample collection, analysis and reporting protocol in accordance with RCNY Title 15 Chapter 1 and 12 NYCRR Part 56, as applicable to the location or work.
  - d. Health and safety protocol for all investigation activities.
- 3. Asbestos Inspection Report: The Contractor shall provide an Asbestos Inspection Report summarizing the results of all inspection activities, and as applicable, a sampling narrative, laboratory data packages and inventory of all identified suspect and confirmed asbestos-containing materials. All reporting shall be in accordance with RCNY Title 15, Chapter 1 and 12 NYCRR Part 56, as applicable to the location or Work.
- 4. Asbestos Work Plan: Each Contractor that will disturb ACM during the course of Work to be performed under this Section shall submit a detailed, project-specific Asbestos Work Plan that addresses Work procedures and equipment to be used during the disturbance, abatement, removal, handling, collection, cleanup, and disposal of ACM and Asbestos-Containing Waste Materials. The Asbestos Work Plan shall be prepared in accordance with RCNY Title 15, Chapter 1 or 12 NYCRR 56, and all other pertinent federal, state, and local regulations. In addition, the Asbestos Work Plan shall follow all applicable DEP EHS Policies and Procedures and shall be coordinated with the Engineer. The Asbestos Work Plan shall also be signed and dated by a NYSDOL-certified Project Designer meeting the definition in this Section. A copy of the Project Designer's current NYSDOL certification shall be attached to the Work Plan. The Asbestos Work Plan shall include the following elements:
  - a. Asbestos Control:
    - 1) Drawings showing the location and details of the following: (a) each Regulated Asbestos Work Area; (b) the type, location, and number of negative air pressure machines that will be used, as well as all exhaust locations; (c) proposed electrical hookups and temporary electrical panels; (d) proposed water hookups; (e) each Restricted Area; (f) each Personal Decontamination Enclosure System; (g) each Waste Decontamination Enclosure System; (h) each waste storage area (e.g., dumpster, trailer, or roll-off); (i) restroom areas; (j) areas designated for eating and drinking.
    - 2) A detailed discussion regarding the interfacing of trades (i.e., how the Contractor will coordinate the Work with other contractors or DEP employees working at the site) and the sequencing of asbestos-related Work.



- 3) A detailed discussion regarding the collection, handling procedures, cleanup, and disposal of Asbestos-Containing Waste Materials (including the collection, filtering, and disposal of wastewater).
- 4) A detailed discussion regarding the procedures and methodologies that will be used to conduct Exposure Monitoring. Provide the name and qualifications (i.e., training and experience documentation) of the individual who will be responsible for conducting the Exposure Monitoring.
- 5) A detailed discussion regarding housekeeping procedures to be used for maintaining clean Regulated Abatement Work Areas, clean Restricted Areas, and clean decontamination enclosure systems.
- 6) A detailed discussion regarding the specific methods and procedures that will be used to control fiber releases, and ensure that as per 40 CFR Part 763, Subpart E, of the EPA Asbestos in Schools Rule measured by Phase Contrast Microscopy (PCM), fiber concentrations less than or equal to the clearance and action criteria of 0.01 f/cc of air, or background levels (whichever are greater), are not exceeded outside of each Regulated Abatement Work Area. For projects conducted outside of the five boroughs of New York City, the clearance and action criteria is less than 0.01 f/cc; of air, or background levels (whichever is greater).
- 7) A detailed task analysis for each Work activity that has the potential to disturb ACM or Asbestos-Containing Waste Materials. Each task analysis shall include, but is not limited to, the following information: (a) the type of Work activity; (b) the tools/equipment that will be used; (c) operation and maintenance practices and procedures that will be used for the tools/equipment; (d) the types of ACM that will be disturbed, or Asbestos-Containing Waste Materials that may be generated when performing the activity; (e) the engineering controls that will be used to control the spread of asbestos fibers during the activity; (f) the proposed crew size for the activity and individual employee responsibilities during the activity; (g) housekeeping procedures that will be used during the activity; (h) PPE and proposed respiratory protection that will be used for the activity.

- 8) Equipment and Supplies: Identify the materials and equipment that will be used to perform the Work, including materials and equipment designed to be non-combustible or fire retardant in accordance with NFPA 701 and 255. Materials and equipment utilized for Abatement activities that take place within the five boroughs, shall conform to RCNY Title 15 Chapter 1-61.
  - 9) Rental Equipment Notification: If rental equipment is to be used during the Work, the Contractor shall notify the rental agency in writing concerning the intended use of the equipment, and shall develop and submit an equipment decontamination plan to the Engineer for review and approval prior to the start of Work.
  - 10) Safety Data Sheets (SDSs): Provide SDSs for all chemical products (including wetting agents and encapsulants) to be used for the Work.
- b. Waste Management:
- 1) A description of the types of ACM and Asbestos-Containing Waste Materials associated with the Work (include details regarding whether the materials are friable or non-friable) as per 49 CFR 171 and 172.
  - 2) The estimated quantity of each waste stream that will be generated as per 40 CFR 302.
  - 3) The name, address, phone number, and qualifications of each vendor and facility that will be transporting, storing (including transfer stations), or disposing of the wastes. The Contractor shall verify the permit status of the facility as well as check for outstanding violations and enforcement actions. Include a 24-hour phone contact for each vendor and facility.
  - 4) Current permit documentation for the disposal facility indicating that the facility is approved by federal, state, and local regulatory agencies to receive Asbestos-Containing Waste Materials. The documentation shall include an “acceptance letter” from the facility indicating its ability to accept the specific asbestos waste streams that will be generated during this Contract Work.
  - 5) Current 6 NYCRR 364 and 49 CFR 173 permit documentation for the waste transporter that will

transport Asbestos-Containing Waste Materials from the Work Site to the disposal facility. The documentation shall clearly indicate the transporter's ability to deliver the Asbestos-Containing Waste Materials to the chosen disposal facility.

- 6) Spill prevention, Containment, and cleanup contingency measures to be implemented during the Work, as well as procedures to be followed during a suspected fiber release or emergency situation. All measures and procedures shall be in accordance with the standards referenced in this Section, including, but not limited to 49 CFR 172.
  - 7) A detailed discussion of the on-site handling, storage, Removal, cleanup, and disposal of waste materials. This discussion shall include, but is not limited to, the following: (a) the methods of demarcation that will be used to identify the waste storage areas and each waste bag/container; (b) the methods and procedures that will be used to collect and containerize wastes on a daily basis; (c) the types of bags/containers that will be used to containerize the wastes; (d) the submittal of weekly waste inspection records as required in this Section.
- c. The name and qualifications (i.e., experience and training documentation) of the Asbestos Handler Supervisor who will be responsible for the oversight and execution of the Asbestos Control Plan during activities affecting ACM. At a minimum, the Asbestos Handler Supervisor shall satisfy the qualification requirements set forth in this Section, and shall be onsite during all activities affecting ACM.
  - d. Asbestos Abatement Project Notifications and Permits: Submit completed permits and notifications to the Engineer for review and approval prior to submittal to the applicable agencies. All Large Asbestos Projects and Small Asbestos Projects that take place within the five boroughs are required to follow notification and permitting procedures per RCNY Title 15, Chapter 1. All Large Asbestos Projects require notification procedures per 12 NYCRR 56. Documents that may be required based upon the scope and location of the project include, but are not limited to, the following:
    - 1) EPA Large Asbestos Project Notification;
    - 2) DEP Asbestos Assessment Report (Form ACP-5);

- 3) DEP Asbestos Project Notification (Form ACP-7);
  - 4) DEP Asbestos Project Amendment (Form ACP-8);
  - 5) DEP Asbestos Variance Application (Form ACP-9);
  - 6) DEP Asbestos Technical Review Unit Permit (A-TRU Permit);
  - 7) DEP Work Place Safety Plan;
  - 8) NYSDOL Asbestos Project Notification;
  - 9) NYSDOL Asbestos Variance Application.
- e. A detailed schedule for the implementation of the Asbestos Work Plan elements. The schedule shall address the different phases of the Asbestos Project, including the projected start and completion dates for Restricted Area preparation, gross Removal and Abatement, cleanings, Clearance Air Monitoring, and demobilization activities.
- f. Medical Surveillance: For all activities that take place within a Regulated Abatement Work Area, the Contractor shall provide a sufficient number of properly trained, experienced, and certified workers, each of whom shall: (a) have received a medical exam that included a Pulmonary Function Test (PFT) within the past year; (b) have received written medical clearance within the past year, by a licensed physician, to wear a respirator; (c) have received a qualitative or quantitative respirator fit-test within the past year for the specific respirator the employee will be using for this Work.
- g. Employee Documentation: For all activities that take place within a Regulated Abatement Work Area, the Contractor shall provide a sufficient number of properly trained, experienced, and certified workers, each of whom shall: (a) have current NYSDOL-issued and DEP-issued asbestos certificates shall be considered proof of training; (b) documentation for Asbestos Handlers and Asbestos Handler Supervisors that will be used for each Asbestos Project, indicating work experience as required in this Section; (c) dates and written proof of initial medical surveillance and all subsequent examinations by the Contractor or other employer within the past year, and proof that the employee is currently participating in the employer's ongoing medical surveillance program in accordance with this Section; (d) dates and written proof of respiratory clearance and a completed medical exam in accordance with this Section; (e)

dates and written proof of a respirator fit-test in accordance with this Section.

- h. A current (i.e., within the last month) signed and notarized statement disclosing all of the Contractor's OSHA, EPA, NYSDOL, DEP, DSNY, and DOT citations/violations on Asbestos Projects within the past three (3) years. If the Contractor will be using a subcontractor, a current signed and notarized statement disclosing all of the subcontractor's OSHA, EPA, NYSDOL, DEP, DSNY, and DOT citations/violations within the past three (3) years will also be required.
  - i. A current (i.e., within the last month) signed and notarized statement disclosing all of the Asbestos Handler Supervisor's NYSDOL and DEP citations/violations within the past three (3) years.
  - j. Analytical Laboratory Qualifications for Analyzing Air Samples: Submit the name, address, and telephone number of each analytical laboratory selected to perform the analyses of all air samples collected for Exposure Monitoring purposes. The analytical laboratory shall be currently accredited by the American Industrial Hygiene Association (AIHA) and NYSDOH ELAP (10 NYCRR 55-2). Provide copies of current AIHA and ELAP certificates along with dates of accreditation/reaccreditation. ELAP certificates should show evidence of certification for the specific analytical methods that will be used.
- 5. Documentation: Complete documentation of all Exposure Monitoring activities shall be in accordance with this Section.
  - 6. The Contractor shall submit all Exposure Monitoring results to the DEP no later than 24-hours after the collection of the air samples.
- B. Logs and Recordkeeping: During all Work performed under this Section, the Contractor shall maintain and provide the following documentation:
- 1. Exposure Monitoring Documentation: Exposure Monitoring Documentation shall be created and shall be made available to the DEP immediately upon request. All laboratory analytical results shall be accompanied by complete COC documentation.
    - a. The Exposure Monitoring documentation shall be signed by the individual who generated the documentation. The content of the documentation shall include, but is not limited to, the following information: (a) sample "start" and "stop" times; (b) flow rates (initial and final) for each sample; (c) the total volume of air

collected for each sample; (d) names of individuals being sampled along with the specific Work task each individual is performing; (e) specific respiratory protection and PPE worn by each individual; (f) types (i.e., makes and models) of sampling equipment used; (g) types of sample media (i.e., filters and cassettes) used; (h) the most recent calibration dates, along with the calibration results, for the sampling equipment used; (i) name of the individual who conducted the Exposure Monitoring; (j) dates that the Exposure Monitoring was conducted; (k) Work tasks being performed adjacent to the Restricted Area during the Exposure Monitoring; (l) unique sample numbers used to identify each sample; (m) the phase of the Asbestos Project being performed (i.e., background, pre-abatement, Abatement, cleaning, or clearance).

2. Waste Manifest Documentation: A Waste Profile for all asbestos waste shall be completed and submitted to the Engineer for review and approval prior to DEP signature. The Contractor shall submit a Letter of Acceptance form from the selected asbestos-permitted landfill stating that the facility will accept the asbestos wastes generated during abatement. The Contractor shall also submit advance copies of the completed manifest for the Engineer's review and approval, prior to NYCDEP signature on the date of disposal. Following disposal, completed and signed waste manifests from the approved, asbestos-permitted landfill, shall be provided to the DEP within 10 business days of disposal. In addition, on-site waste storage areas shall be inspected weekly by the Asbestos Handler Supervisor.
3. Waste Storage Area Inspection Documentation: Each weekly waste storage area inspection shall be documented in the Asbestos Abatement Contractor's bound Log. The Log shall be signed by the Asbestos Handler Supervisor, and shall be made available to the DEP immediately upon request. The content of this documentation shall include, but is not limited to, the following information: (a) the name of the individual that conducted the inspection; (b) descriptions of waste streams being stored; (c) types and quantities of waste containers being used; (d) the current disposal status (i.e., when the waste container is scheduled to be removed from the Work Site) and physical condition of each waste container; (e) the present condition of each waste storage area; (f) the presence/absence of proper labeling for each waste container in accordance with this Section and federal, state, and local regulations.; (g) the methods being used to secure/lock each waste storage area to prevent unauthorized entry.

4. Asbestos Project Inspection Documentation: Project Monitors and Restricted Areas shall be inspected daily by the Asbestos Handler Supervisor.
  - a. Each daily Asbestos Project inspection shall be documented in the Asbestos Abatement Contractor's bound Log. The Log shall be signed by the Asbestos Handler Supervisor, and shall be made available to the DEP immediately upon request. The content of the Log shall include, but is not limited to, the following information: (a) the type of Asbestos Project (i.e., Large Asbestos Project, Small Asbestos Project, or Minor Asbestos Project) being conducted; (b) the current phase of the Asbestos Project (i.e., mobilization, background pre-Abatement, abatement, cleaning, Clearance Air Monitoring, or Containment breakdown); (c) the names of the Asbestos Handlers, Asbestos Handler Supervisors, Project Monitors, and Air Sampling Technicians on site, as well as the name of the company each individual is representing; (d) the types of air monitoring (i.e., Exposure Monitoring or area monitoring) being conducted, and the number of samples being collected for each type of air monitoring activity; (e) the results of decontamination enclosure system, Critical Barrier, Isolation Barrier, and Negative Air Pressure Equipment inspections; (f) a summary of corrective actions and Repairs; (g) Work stoppages and the reasons for the work stoppage; (h) manometer readings (at least twice per work shift); (i) emergency and fire exit checks; (j) verification that functional fire extinguishers are present in the Restricted Areas; (k) any unusual events that occurred during the Work; (l) non-compliance issues observed (i.e., observations that conflict with the requirements of the Contractor's Asbestos Work Plan, this Section, DEP EHS Policies and Procedures, or federal, state, and local regulations) along with the corrective actions that were taken to achieve compliance.
5. Contractor Project Record: The Asbestos Handler Supervisor shall maintain a project record in the Regulated Abatement Work Area. The Contractor Project Record shall be made available to the Engineer or DEP for review at any time during the Asbestos Project, and shall be submitted to the DEP within 24- hours after the completion of the Asbestos Project.
  - a. At a minimum, the Contractor Project Record shall contain the following information: (a) copies of DEP and NYS DOL asbestos certificates/licenses for all individuals/companies working on the Asbestos Project; (b) copies of all notifications, amendments, permits, work safety plans, and Variances related

to the Asbestos Project; (c) copies of all exposure and Ambient Air Monitoring results generated during the Asbestos Project; (d) documentation of all pressure differential readings for Regulated Abatement Work Areas; (e) copies of all available bulk sample analytical data as well as asbestos survey reports relating to the Asbestos Project; (f) copies of all daily sign-in sheets as defined in this Article; (g) a list of emergency phone numbers, including the local fire department, local police department, nearest hospital, as well as phone numbers for the Engineer and DEP personnel responsible for administering the Asbestos Project; (h) a copy of New York City's Asbestos Control Program Rules and Regulations (Title 15, Chapter 1); (i) a copy of New York State's Asbestos Rules and Regulations (12 NYCRR 56); (j) a copy of EPA's asbestos regulations (40 CFR 61, Subparts A and M); (k) copies of all SDSs pertaining to all chemicals being used during the Asbestos Project; (l) a copy of this Section; (m) a copy of the Contractor's Asbestos Work Plan; (n) copies of all daily air monitoring reports as defined in this Article; (o) copies of all daily Asbestos Project inspection reports as defined in this Article; (p) copies of all weekly waste storage area inspection reports as defined in this Article; (q) copies of all DEP EHS Policies and Procedures identified in this Section.

6. Daily Sign-In Documentation: The Contractor shall generate daily sign-in documentation for all individuals entering and exiting each Regulated Abatement Work Area and Restricted Area, for the duration of the Asbestos Project. The daily sign-in documentation shall be maintained in the Asbestos Abatement Contractor's bound Log. The daily sign-in documentation shall be made available to the Engineer or DEP for review at any time during the Asbestos Project.
  - a. At a minimum, daily sign-in documentation shall include: (a) the individual's full name (printed); (b) the individual's signature; (c) the name of the company the individual is representing; (d) the times of entry and exit from the Restricted Area; (e) verification by the Asbestos Handler Supervisor that the individual possesses current DEP and NYSDOL asbestos certifications if the individual intends to enter a Regulated Abatement Work Area.



**PART 2        PRODUCTS**

**2.01        MATERIALS**

- A.    Respirators: The Contractor shall select respirators approved by NIOSH for use in Regulated Abatement Work Areas where the Abatement or Disturbance of ACM or Asbestos-Containing Waste Materials will occur. If not included within the EHASP the Contractor shall submit their Respiratory Protection Program to DEP for review prior to abatement activities. At a minimum, the Contractor shall provide each individual within a Regulated Abatement Work Area with a half-face, negative pressure, air purifying respirator equipped with HEPA filter cartridges. The Contractor's Asbestos Handler Supervisor shall make all determinations regarding respiratory protection modifications that will be implemented for the Work. All modifications shall be in accordance with the OSHA Asbestos Standard for the Construction Industry (29 CFR 1926.1101) and the Contractor's Asbestos Work Plan. At no time during the Asbestos Project shall respiratory protection within a Regulated Abatement Work Area be downgraded to below the minimum requirement of a half-face, negative pressure, air purifying respirator equipped with HEPA filter cartridges.
- B.    PPE: The Contractor shall provide personnel who have a potential to be exposed to asbestos with appropriate PPE.
- C.    HEPA Filters: HEPA filters used in vacuuming equipment and Negative Air Pressure Equipment must meet or exceed any manufacturer's specifications and recommendations, as well as specifications presented in the Standard for Safety High Efficiency, Particulate, Air Filter Units (UL 586).
- D.    Containment Materials: Plastic sheeting used in the construction of temporary enclosures shall be fire retardant in accordance with NFPA 701. Wood or other materials used in the construction of temporary enclosures shall be non-combustible or fire-retardant in accordance with NFPA 255, ASTM D2898, ASTM E84 and UL 723.

**PART 3        EXECUTION**

**3.01        SAFE WORK PRACTICES FOR TRACE ASBESTOS MATERIALS**

- A.    An exposure assessment shall be performed in accordance with 29 CFR 1926.1101(f) (2) (i) to determine if workers disturbing, handling, or performing cleanup activities involving trace asbestos materials, must wear PPE or respiratory protection.
- B.    Wetting agents or special work methods shall be utilized to control potential employee exposures to asbestos during the handling, mixing, removing, cutting, application, or cleanup, of trace asbestos materials, except if the use of these wetting agents/work methods is not feasible (e.g., using them may create electrical hazards or equipment malfunctions).

- C. Asbestos-contaminated wastes and debris shall be cleaned-up promptly and disposed of in leak-tight containers. The handling, disposal, and transport of Trace Asbestos-Containing Material wastes is not regulated since the wastes are not ACM (i.e., they do not contain greater than 1% asbestos).
- D. The use of high-speed abrasive saws that are not equipped with “point-of-cut” ventilators or enclosures with HEPA-filtered exhaust air shall be prohibited.
- E. The use of compressed air to cleanup or remove trace asbestos materials is prohibited.

3.02 PREPARATION

- A. Utilities: The temporary use of any on-site utilities shall be subject to the approval of the DEP. The Contractor shall furnish all water and hoses needed for the Asbestos Project, as well as any temporary hookups. Also, the Contractor shall supply all necessary heating equipment and water filtration devices needed for the Work. In addition, all temporary lighting and temporary electrical service to a Regulated Abatement Work Area or a Restricted Area shall be provided by the Contractor, and shall be in weather-proof enclosures and be ground fault protected.
- B. Signs: The Contractor shall post conspicuous warning signs at all approaches to Regulated Abatement Work Areas, Restricted Areas, and waste storage areas. The signs shall be located at such a distance so that personnel may read the sign and take necessary precautions before entering a Regulated Abatement Work Area, Restricted Area, or waste storage area. Signs shall comply with the requirements of federal, state, and local regulations. Once Clearance Air Monitoring results indicate that a Regulated Abatement Work Area is in compliance with the provisions for re-occupancy set forth in RCNY Title 15, Chapter 1 or 12 NYCRR 56, the signs shall be removed. At a minimum, each sign shall bear the following information in English and the predominant language that is spoken by the Contractor’s employees if English is not spoken:

DANGER  
ASBESTOS CANCER AND LUNG DISEASE HAZARD  
AUTHORIZED PERSONNEL ONLY  
RESPIRATORS AND PROTECTIVE CLOTHING  
ARE REQUIRED IN THIS AREA  
NO SMOKING

- C. Fire Extinguishers: The Contractor shall maintain at least two functional fire extinguishers in each Restricted Area. The fire extinguishers shall have a minimum rating of 2-A:10-B:C, and each fire extinguisher shall be checked daily by the Asbestos Handler Supervisor to ensure that it remains functional throughout the duration of the Asbestos Project.

3.03 AIR MONITORING

- A. Exposure Monitoring: Air monitoring for airborne concentrations of asbestos fibers shall be conducted by the Asbestos Handler Supervisor (or by a qualified air monitoring firm) in accordance with OSHA.
1. The Contractor shall collect personal air samples from employees who are anticipated to have the greatest risk of exposure, as determined by the Contractor. Exposure Monitoring shall be conducted during each phase of the Asbestos Project (e.g., pre-abatement, Abatement, and cleanup) for one (1) Work shift from at least one (1) employee that is representative of each type of Work task that is being performed. Each personal air sample will “run” for the employee’s entire Work shift in order to ensure that enough volume (of air) is collected and an accurate 8-hour TWA can be calculated. Representative 30-minute short-term employee exposures shall also be conducted and shall be determined on the basis of one or more samples representing 30 minute exposures associated with operations that are most likely to produce exposures above the excursion limit for employees in each Regulated Abatement Work Area as per OSHA 1926.1101(f)(1)(iii). Documentation regarding the sample numbers, specific shift when the sampling was conducted, the Work tasks that were sampled, the dates of sampling, the employee hours that were worked during the shift, and the total sampling times, shall accompany each laboratory COC form.
  2. Complete documentation of all Exposure Monitoring activities shall be in accordance with this Article.
  3. The Contractor shall submit all Exposure Monitoring results (along with documentation regarding the type of respiratory protection that was worn during the Exposure Monitoring) to the DEP within 24- hours from when the air samples were collected.
  4. If at any time, PCM analysis of any air sample (i.e., from Exposure Monitoring performed by the Contractor) in any phase of the Asbestos Project (i.e., pre-abatement, Abatement, cleanup, or clearance) indicates that the filter was “overloaded” and a fiber count cannot be obtained, the sample shall immediately undergo TEM analysis. All costs of the additional TEM analysis will be at the Contractor’s expense.
- B. Area Monitoring: Air monitoring for airborne concentrations of asbestos fibers shall be conducted by the DEP. The Contractor shall assume that area monitoring will be conducted on all Asbestos Projects (regardless of the project type, the project size, or any conflicting applicable Variance) unless the DEP makes a determination that area monitoring for a specific project is not necessary.

1. All Clearance Air Monitoring results shall meet or be below background ambient air levels or 0.01 f/cc of air (whichever is greater), prior to the breakdown of the Containment. If Clearance Air Monitoring results indicate a fiber count greater than background ambient air levels or 0.01 f/cc of air in any area, the Contractor will be required to re-clean that area. For projects conducted outside of the five boroughs, the clearance and action criteria is less than 0.01 f/cc; of air, or background levels (whichever is greater). Repeated cycles of cleaning and Clearance Air Monitoring will be performed until a fiber count is achieved that meets or is below background ambient air levels or 0.01 f/cc of air within the area. All costs of re-cleaning and additional Clearance Air Monitoring will be at the Contractor's expense.

#### 3.04 BULK REMOVAL

- A. Protection of Existing Work to Remain: All Work involving the Abatement or Disturbance of ACM or Asbestos-Containing Waste Materials, must be conducted without damage to, or contamination of equipment or surfaces within the Regulated Abatement Work Areas, Restricted Areas, or other areas adjacent to these areas. All such damage or contamination shall be immediately corrected and cleaned up by the Contractor at the Contractor's expense.
- B. Containments and Negative Air Pressure Equipment: Pressure differential readings for each workday shall be obtained and reviewed by the Asbestos Handler Supervisor on a daily basis. All readings shall be documented and kept in the Contractor's Project Record, as required in this Section. The Asbestos Handler Supervisor shall notify the Engineer and the DEP immediately, if any variations in the pressure differential readings may have led to the migration of asbestos fibers outside of a Regulated Abatement Work Area. Corrective actions shall be implemented immediately to ensure that negative pressure is restored.
- C. Personal Decontamination Enclosure System: The Contractor shall ensure that employees do not leave a Regulated Abatement Work Area wearing any potentially contaminated protective work clothing or PPE. Employees are required to shower prior to leaving the Regulated Abatement Work Area.

#### 3.05 CLEANUP AND DISPOSAL

- A. Cleanup: All cleaning Work shall progress from the point most remote from the intakes of the Negative Air Pressure Equipment, towards the intakes of the equipment, as well as from the highest point of the surfaces to be cleaned towards the lowest point of the surfaces. The Contractor shall maintain all surfaces, including protective tarps, polyethylene sheeting, and coverings within each Regulated Abatement Work Area and each Restricted Area, free of accumulations of dusts, wastes, and debris. The Contractor shall perform housekeeping activities daily throughout each work shift and at the end of each

work shift, in order to prevent any accumulation of dusts, wastes, and debris in these areas. Dry sweeping and using compressed air to cleanup a Regulated Abatement Work Area or a Restricted Area is strictly prohibited. HEPA-filtered vacuums and Wet Cleaning methods shall be used to ensure that these areas remain free of visible dust and debris. In addition, only cleaning materials and equipment which are compatible with the surface being cleaned, as recommended by the manufacturer of the materials or as approved by the DEP, shall be used.

- B. Collection, Containerization, and Filtration of Wastes: The Contractor shall collect and containerize asbestos waste (solid and liquid), debris, PPE, and Containment materials on a daily basis in accordance with the Asbestos Work Plan. Using chutes to move construction debris or waste (bagged or not bagged) will not be permitted at any time.
1. Prior to containerizing Asbestos-Containing Waste Materials, the wastes shall be “Adequately Wetted,” in accordance with this Section, and wrapped in 6-mil (0.006”) polyethylene sheeting, or double-bagged in 6-mil polyethylene bags. The bags shall be “goose necked” and sealed air tight with duct tape, and each bag (or wrapped item) shall be labeled in accordance with this Section before being placed in an appropriate container (i.e., dumpster, trailer, or roll-off) for disposal.
  2. Corrugated cartons or drums may be used in conjunction with polyethylene bags and sheeting for the disposal of Asbestos-Containing Waste Materials that have sharp-edged components (e.g., nails, screws, or tin sheeting) which may tear the bags or sheeting. The waste within these drums or cartons must be wrapped or double-bagged in accordance with this Section. In addition, the cartons/drums must be labeled in accordance with this Section.
  3. Wastewater derived from the Asbestos Project shall be collected and filtered through a system with at least a 5.0 micron particle size collection capability. A system containing a series of several filters with progressively smaller pore sizes shall be used to avoid the rapid clogging of the filtration system by large particles. Contaminated filters shall be disposed of as asbestos waste. Filtered wastewater shall be discharged in accordance with all applicable federal, state, and local regulations.
    - a. Discharging filtered asbestos decontamination water to a DEP Wastewater Treatment Plant (WWTP) will require written permission from the DEP Bureau of Wastewater Treatment (BWT) and the submission of analytical testing results for asbestos to the BWT for review and approval prior to discharge. This procedure only applies to Asbestos Projects being conducted at a DEP WWTP. The disposal requirements for

filtered asbestos decontamination water generated on other DEP properties (e.g., drinking water shafts) may be more stringent or prohibited.

4. The Contractor shall store all bagged Asbestos-Containing Waste Materials in DOT-approved container systems (e.g., a roll-off or trailer), as per 49 CFR 178. No container shall be filled in excess of the capacity marked on the container, and all containers shall be lined with 6-mil (0.006”) polyethylene sheeting, have a hard top, and shall be locking in addition to meeting any other federal, state, and local asbestos waste storage requirements. In addition, all containers shall have an intact and legible label affixed to it in accordance with this Section. No bagged asbestos waste shall be stored in a Regulated Abatement Work Area or decontamination enclosure system for longer than the current Work shift that generated the waste.
  5. Non Asbestos Waste: The Contractor shall store non Asbestos-Containing Waste Materials separately from Asbestos-Containing Waste Materials, shall provide all non-asbestos waste containers, and shall make all transportation and disposal arrangements for non-Asbestos-Containing Waste Materials in accordance with federal, state, and local regulations.
- C. Labeling: The Contractor shall affix warning labels to all asbestos waste disposal bags, wrapped items, and containers (i.e., drums, dumpsters, trailers, or roll-offs). Labels shall comply with the requirements of federal, state, and local regulations. At a minimum, each label on disposal containers/bags/items shall bear the following information in English:

DANGER  
CONTAINS ASBESTOS FIBERS  
AVOID CREATING DUST  
CANCER AND LUNG DISEASE HAZARD

[Generator Name, Address, and Telephone Number]

- D. Final Visual Inspection and Clearance Air Monitoring: The Independent Third Party Monitor shall not conduct Clearance Air Monitoring until the Regulated Abatement Work Area has been inspected by the Asbestos Handler Supervisor and the Project Monitor has performed the Final Visual Inspection. During this inspection, the Asbestos Handler Supervisor and the Project Monitor shall determine if the following has been achieved: (a) all ACM and Asbestos-Containing Waste Materials have been abated and removed from the area; (b) the area is clean and dry; (c) Critical Barriers and Isolation Barriers are intact;

- (d) Negative Air Pressure Equipment is turned on and functioning. If any of these items have not been achieved, the Contractor shall perform the necessary corrective actions to achieve compliance before conducting the Clearance Air Monitoring.
- E. Breakdown of the Regulated Abatement Work Area: Critical Barriers shall not be removed and Negative Air Pressure Equipment shall not be turned off until Clearance Air Monitoring results meet the criteria specified in this Section and RCNY Title 15, Chapter 1 or 12 NYCRR 56.
- F. Asbestos Project Completion (Form ACP-21)/ Asbestos Project Conditional Completion (Form ACP-20): Upon successful completion of an Asbestos Project performed in the five boroughs, a copy of the ACP-21 or ACP-20 issued by the DEP shall be submitted to the Engineer.
- G. Disposal of Wastes: The Contractor shall notify the DEP at least five business days prior to the removal of any waste containers, so that the DEP can inspect the containers and review and approve the advance copies of all waste manifests. Asbestos-Containing Waste Materials shall be disposed of to ensure that containers do not remain on the job site for longer than necessary. Containers that have reached their storage capacity shall not remain on site and transportation arrangements shall be made for their Removal.
- H. Disposal Documentation: The Contractor shall submit written evidence that the landfill receiving Asbestos-Containing Waste Materials is approved by federal, state, and local regulatory agencies to receive the wastes. If regulated PCBs (as defined in Section 13284 - PCBs Management) were detected in the wastes, the contractor will also ensure that the landfill is approved by federal, state, and local regulatory agencies to receive PCB-regulated wastes. On the date of disposal the Contractor shall submit one (1) copy of the completed manifest that has been signed and dated by the initial transporter in accordance with 6 NYCRR 372, 40 CFR 262 and 40 CFR 302, to the DEP for signature as Generator. All manifests and Land Disposal Restrictions (LDRs) must be signed by a DEP employee per 6 NYCRR 376 and 40 CFR 268, and as described in Section 01355 - Hazardous Materials Control.

END OF SECTION

NO TEXT ON THIS PAGE



**SECTION 13282  
Mercury Management**

**PART 1 GENERAL**

**1.01 SUMMARY**

- A. This Section details the requirements for construction and demolition activities affecting materials containing mercury, as shown on the Drawings, specified herein, or required to complete the Work, including all mercury and mercury-containing equipment identified and impacted by the Work. All Work under this Section shall be performed using methods that have a demonstrated effectiveness in minimizing the quantity of hazardous waste generated; protecting the health and safety of all site personnel and the welfare of the public; and avoiding adverse environmental impacts.
- B. The Contractor shall perform the removal and recycling/disposal of additional materials containing mercury not shown on the Drawings. Unless otherwise specified, the Work of this Section shall also be performed in accordance with the most current DEP Environmental Health and Safety (EHS) Policies and Procedures (including Mercury Management, Hazardous Waste Management, and Spill Prevention, Environmental Release Reporting and Investigation), DEP Bureau of Engineering Design and Construction (BEDC) EHS Standards, and applicable federal, state, and local regulations.
- C. All mercury-containing wastes generated during this Contract Work that qualify as Universal Wastes under federal, state, or local regulations, must be recycled (and not disposed of as hazardous wastes) regardless of the quantity of wastes generated.
- D. The Contractor shall perform all Work under this Section without damaging or contaminating adjacent areas to where the Work is being performed. Where such areas are damaged or contaminated, as determined by DEP, the Contractor shall restore the areas to their original condition at no additional cost to the City.
- E. The following index of this Section is presented for convenience:

<u>Article</u>	<u>Title</u>	<u>Page</u>
		13282-
PART 1	GENERAL.....	1
1.01	Summary.....	1
1.02	Payment.....	2
1.03	Related Sections.....	2
1.04	Reference Standards.....	2
1.05	Definitions.....	4
1.06	Description.....	7
1.07	Quality Assurance.....	8

## GENERAL SPECIFICATION 13282 - MERCURY MANAGEMENT

---

1.08	Submittals .....	9
PART 2	PRODUCTS.....	15
2.01	Materials .....	15
PART 3	EXECUTION.....	16
3.01	Preparation .....	16
3.02	Removal .....	17
3.03	Cleanup and Disposal .....	17

### 1.02 PAYMENT

- A. Except for unforeseen mercury-containing materials and related Work payable under the allowance, as described in Section 01355 – Hazardous Materials Control, no separate payment will be made for performing any Work required under this Section and the Contractor shall include all costs thereof in its prices bid for the Contract.
- B. Payment for disposal of mercury-containing materials and mercury wastes will not be made until a signed copy of the manifest from the recycling facility/Treatment, Storage, and Disposal Facility (TSDF), certifying the amount of mercury-containing materials and mercury wastes delivered is returned with complete chain-of custody (COC) documentation to DEP.

### 1.03 RELATED SECTIONS

- A. Detailed Specification 01355 - Hazardous Materials Control
- B. Detailed Specification 01356 - Environmental Health and Safety Requirements
- C. Detailed Specification 01733 - Construction Waste Management
- D. Detailed Specification 13283 - Lead Management
- E. Detailed Specification 13284 - PCB Management

### 1.04 REFERENCE STANDARDS

- A. The Contractor shall comply with all applicable regulations, standards, and guidelines of federal, state, and local environmental and occupational safety and health agencies regarding Mercury-Containing Materials and Mercury Wastes. These regulations, standards, and guidelines include, but are not limited to the following:
  - 1. United States (U.S.) Department of Transportation (DOT):
    - a. 49 CFR 171 - General Information, Regulations, and Definitions;
    - b. 49 CFR 172 – Hazardous Materials Table, Special Provisions, Hazardous Materials Communications, Emergency Response Information, and Training Requirements;

## GENERAL SPECIFICATION 13282 - MERCURY MANAGEMENT

---

- c. 49 CFR 173 – Shippers: General Requirements for Shipments and Packaging’s;
  - d. 49 CFR 178 – Specifications for Packaging’s.
2. U.S. Environmental Protection Agency (EPA):
- a. 40 CFR 116 – Designation of Hazardous Substances;
  - b. 40 CFR 117 – Determination of Reportable Quantities for Hazardous Substances;
  - c. 40 CFR 260 – Hazardous Waste Management Systems: General;
  - d. 40 CFR 261 – Identification and Listing of Hazardous Waste;
  - e. 40 CFR 262 – Standards Applicable to Generators of Hazardous Waste;
  - f. 40 CFR 263 – Standards Applicable to Transporters of Hazardous Waste;
  - g. 40 CFR 264 – Standards for Owners and Operators of Hazardous Waste Treatment, Storage, and Disposal Facilities;
  - h. 40 CFR 265 – Interim Status Standards for Owners and Operators of Hazardous Waste Treatment, Storage, and Disposal Facilities;
  - i. 40 CFR 268 – Land Disposal Restrictions;
  - j. 40 CFR 273 – Standards for Universal Waste Management;
  - k. 40 CFR 302 – Designation, Reportable Quantities, and Notification.
3. New York City Department of Environmental Protection (DEP):
- a. Environmental Health and Safety Policies and Procedures – Vol. II, Spill Prevention, Environmental Release Reporting and Investigation;
  - b. Environmental Health and Safety Policies and Procedures – Vol. III, Mercury Management;
  - c. Environmental Health and Safety Policies and Procedures – Vol. IV, Hazardous Waste Management;
  - d. Environmental Health and Safety Policies and Procedures – Vol. IV, Universal Waste Management;
  - e. 15 RCNY Chapter 19 – Discharges of Wastewater and Other Materials to Public Sewers.
4. New York City Department of Buildings (NYCDOB)

- a. New York City Building Code.
5. New York State Department of Environmental Conservation (NYSDEC):
  - a. 6 NYCRR 364 – Waste Transporter Permits;
  - b. 6 NYCRR 370 – Hazardous Waste Management Regulations;
  - c. 6 NYCRR 371 – Identification and Listing of Hazardous Waste
  - d. 6 NYCRR 372 – Hazardous Waste Manifest System and Related Standards for Generators, Transporters, and Facilities;
  - e. 6 NYCRR 373 – Hazardous Waste Management Facilities;
  - f. 6 NYCRR 374 – Management of Specific Hazardous Waste;
  - g. 6 NYCRR 376 – Land Disposal Restrictions;
6. Chapter 145, Laws of New York, 2004 – Mercury-Added Consumer Products Law.
7. National Institute for Occupational Safety and Health (NIOSH):
  - a. NIOSH Pocket Guide to Chemical Hazards.
8. Occupational Safety and Health Administration (OSHA):
  - a. 29 CFR 1910 – Occupational Safety and Health Standards
  - b. 29 CFR 1910.28 – Safety Requirements for Scaffolding
  - c. 29 CFR 1910.120 – Hazardous Waste Operations and Emergency Response
  - d. 29 CFR 1910.1200 - Hazard Communication Standard
  - e. 29 CFR 1926 – Safety and Health Regulations for Construction
9. Underwriters Laboratories, Inc. (UL):
  - a. UL 586 – Standard for Safety High Efficiency, Particulate, Air Filter Units.

1.05 DEFINITIONS

- A. Certified Industrial Hygienist (CIH): Refers to an individual employed by the Contractor or its Subcontractors who is currently certified by the American Board of Industrial Hygiene (ABIH).
- B. Competent Person: Defined by OSHA as one who is capable of identifying existing and predictable hazards in the surroundings or working conditions, and who has authorization to take prompt corrective measures to eliminate them. The Competent Person shall fulfill the requirements of this Section. Duties of the Competent Person include the following: (a) determining prior to the

- performance of the Work, what contaminants are present in the workplace; (b) establishing work areas and assuring that access to and from those areas is limited to authorized personnel; (c) assuring the adequacy of any employee exposure monitoring required by OSHA; (d) assuring that all employees exposed to airborne contaminant levels above Action Levels, Permissible Exposure Limits (PELs), or Recommended Exposure Limits (RELs) wear appropriate Personal Protective Equipment (PPE), respiratory protection, and are trained in the use of appropriate methods of exposure control for all of the contaminants present; (e) assuring that proper hygiene facilities are provided and that workers are trained to use those facilities; (f) assuring that engineering controls specific to the contaminants present are implemented, maintained in proper operating condition, and functioning properly
- C. DOT Hazardous Materials Transportation Training: Training that meets the criteria outlined in 49 CFR 172.704. This training shall include discussions from 49 CFR 171 of the following: (a) hazardous materials tables within 49 CFR 172; (b) material packaging and labeling within 49 CFR 178; (c) shipping papers and placards within 49 CFR 173; (d) material loading and segregation within 49 CFR 173.
- D. Hazardous Waste Operations (HAZWOPER) Training: Training that meets the criteria outlined in the OSHA Hazardous Waste Operations and Emergency Response Standard (29 CFR 1910.120). A minimum of 24-hour HAZWOPER Training will be required for Work being performed under this Section. However, certain types of Work may require 40-hour HAZWOPER Training. All decisions regarding the specific HAZWOPER Training that will be required for each work task shall be made by the Engineer.
- E. High-Efficiency Particulate Air (HEPA) Filter: A filter designed to remove 99.97% of all particles greater than 0.3 micrometers ( $\mu\text{m}$ ) in diameter. For the purpose of this Section, HEPA vacuum equipment used by the Contractor shall meet the Standard for Safety High-Efficiency, Particulate, Air Filter Units (UL 586) developed by Underwriters Laboratories.
- F. Mercury-Containing Material: Material or device that contains a detectable amount of elemental mercury, inorganic mercury compounds, or organic mercury compounds. Mercury-Containing Materials may include, but are limited to, the following: batteries, light bulbs, thermometers, thermostats, barometers, manometers, temperature gauges, pressure gauges, and switches.
- G. Mercury Awareness Training: Training for individuals that have the potential to be exposed to Mercury-Containing Materials or Mercury Wastes. This training shall include discussions of the following: (a) sources of mercury; (b) current federal, state, and local regulations pertaining to mercury; (c) the health effects of mercury exposure; (d) state-of-the-art work practices, engineering controls, and procedures for removal, materials handling, waste management, housekeeping, and spills that involve mercury; (e) the use and maintenance of

- PPE and the use and maintenance of respirators in accordance with 29 CFR 1910.134; (f) requirements regarding warning signs, labeling, and Safety Data Sheets (SDSs) in accordance with 29 CFR 1910.1200; (g) responsibilities of the Competent Person.
- H. Mercury Waste: Non-specific liquid or solid waste generated during the disturbance, removal, construction/demolition, handling, and cleanup of Mercury-Containing Materials.
  - I. P-100 Filter: (See definition of: “High-Efficiency Particulate Air (HEPA) Filter”).
  - J. Physical Boundary: A physical barrier designated with ropes, red “do not enter tape,” or a partition that surrounds a work area in order to limit the entry of unauthorized personnel and delineate “clean areas” from areas that may meet or exceed an Action Level, PEL, or REL.
  - K. REL: An exposure limit recommended by the NIOSH that can be expressed as a Time-Weighted Average (TWA), Ceiling Limit, or Short-Term Exposure Limit (STEL). Once an REL is met or exceeded for a particular contaminant, the Contractor is responsible for ensuring that workers receive appropriate exposure monitoring, PPE, including respiratory protection, hygiene facilities, medical surveillance, and training. The following REL is pertinent to removal, demolition, and disposal activities associated with Mercury-Containing Materials and wastes: (a) mercury – 0.05 mg/m<sup>3</sup> as a TWA for up to a ten (10) hour workday and a 40-hour work week, and a ceiling limit of 0.1 mg/m<sup>3</sup>, as per DEP EHS Policies and Procedures - Vol. III, Mercury Management.
  - L. Resource Conservation and Recovery Act (RCRA) Training: Training that meets the criteria outlined in 40 CFR 265.16. This training shall include site-specific discussions of the following: (a) hazardous waste identification; (b) waste storage container use and labeling; (c) waste storage area management; (d) personal health and safety, including fire safety; (e) manifesting and the off-site transportation of wastes; (f) procedures for using, inspecting, repairing, and replacing emergency equipment and monitoring equipment; (g) procedures for communicating with other employees and outside emergency response personnel; (h) responses to fires or explosions; (i) responses to leaks, spills, and potential groundwater contamination incidents; (j) the shutdown of operations.
  - M. TWA: The average time over a given work period (e.g., an eight (8) hour workday) of a person’s exposure to a chemical or agent. The average is determined by sampling for the chemical or agent throughout the time period.
  - N. Universal Waste: Any Mercury-Containing Material that meets the criteria outlined in the Standards for Universal Waste Management (40 CFR 273), the Standards for Universal Wastes (6 NYCRR 374-3), or the Mercury-Added Consumer Products Law (Chapter 145, Laws of New York, 2004). Per 40 CFR 273.4(b)(3), if the mercury is removed from a Mercury-Containing Material,

the material can no longer be considered a Universal Waste and must be managed as a hazardous waste, or a determination must be made to characterize the material as non-hazardous.

1.06 DESCRIPTION

- A. Commencement of Work: Five (5) business days prior to the proposed start of Work at each separate location, the Contractor shall notify the Engineer and the onsite safety staff. No Work may proceed at any location until authorized by the Engineer.
- B. The Contractor shall coordinate any required equipment shutdowns with Engineer prior to starting the Work.
- C. Access Restrictions: The Contractor shall inform the Engineer of proposed access restrictions (i.e., areas or items of equipment which will not be accessible during the Work), and give them estimated periods (including specific dates) of such proposed access restrictions. The Contractor shall be aware that Other Contractors may be at the work site. As a result, the Contractor shall not have exclusive rights to the work site, and shall fully cooperate and coordinate this Work with the work of Other Contractors who may be on site. Therefore, the Contractor shall notify Other Contractors in advance of the disturbance, removal, construction/demolition, and disposal Work included herein, to provide them with sufficient time for coordination of interrelated items that are included in their contracts and that must be performed before, after, or in conjunction with the Work included under this Section.
- D. Unexpected Entry into a Work Area: In the event that DEP personnel must enter a work area for reasons unrelated to the supervision or inspection of Work being performed under this Section (e.g., under emergency conditions), the Contractor shall immediately stop work and cleanup any loose debris, so as to permit the safe entry by DEP personnel. Any disturbance of Mercury-Containing Materials or Mercury Wastes shall not proceed until all DEP personnel have exited from the work area.
- E. Meetings: The Contractor shall visit and investigate the site, review the Drawings, review this Section, review DEP EHS Policies and Procedures, and become familiar with any conditions which may affect the Work, as part of the pre-construction meeting and site walk-through. The Contractor shall hold all meetings with appropriate parties as scheduled and as otherwise necessary to accomplish the Work to be performed under this Section. In addition to the pre-construction meeting and site walk-through, other meetings may be required or may be requested by the Engineer, including briefings to Bureau Operations personnel. Written documentation (i.e., “minutes”) of all meetings shall be generated by the Contractor, and copies shall be provided to the DEP within three (3) business days following each meeting.

1.07 QUALITY ASSURANCE

- A. Scheduling: The Contractor shall coordinate and schedule all phases of the Work to be performed under this Section with the DEP, subcontractors, material suppliers, and other parties as necessary to ensure the proper execution of the Work.
- B. Compliance: In addition to the detailed requirements of this Section and DEP EHS Policies and Procedures, the Contractor shall comply with all applicable regulations of federal, state, and local authorities pertaining to the disturbance, removal, construction/demolition, handling, storage, transportation, and recycling/disposal of Mercury-Containing Materials and Mercury Wastes. All matters regarding the interpretation of any regulations, standards, or policies shall be submitted to the Engineer for resolution before starting the Work. Where the requirements of this Section, DEP EHS Policies and Procedures, or federal, state, or local regulations conflict or vary, the most stringent requirements or regulations shall apply. Work shall be coordinated as needed with 29 CFR 1926 and Sections 01355, 01356, 01733, 13283, and 13284.
- C. Rejection of Non-Complying Items: The DEP reserves the right to reject items incorporated into the Work which fail to meet the specified minimum requirements. The DEP also reserves the right to reject Contractor submittal items that are deemed inappropriate or unacceptable by the Engineer or DEP. Submittal items that may be deemed inappropriate or unacceptable include proposed vendors or subcontractors (e.g., TSDFs, etc.) with previous regulatory citations/violations. The DEP further reserves the right, and without prejudice to other recourse, to accept non-complying items subject to an adjustment in the Contract amount, as approved by the DEP.
- D. Qualifications:
  - 1. Mercury Removal Company: The Mercury Removal Company shall have successfully completed at least two (2) projects of comparable scope and methodologies to the Work being performed under this Section within the past three (3) years. This experience shall be documented by identifying the following: (a) the name, address, and phone number of each facility where the work was performed; (b) the name of the individual representing the owner who supervised the work at each facility; (c) the types of facilities where the work was performed; (d) the volume and type of each material that was removed and recycled/disposed of; (e) the specific methods of removal used at each facility (including the tools, technologies, and engineering controls employed);
  - 2. Competent Person: The Contractor and/or Mercury Removal Company shall have on staff and assigned to this Contract a Competent Person who has successfully completed DOT Hazardous Materials



Transportation Training, HAZWOPER Training, Mercury Awareness Training, and RCRA Training courses as defined in this Section. Each training course shall have been completed within the past year in the form of either an initial course or a refresher course. In addition, the Competent Person shall be able to fulfill the duties defined in this Section, shall have a minimum of two (2) years' experience with work involving mercury, and shall have worked on at least three (3) projects of comparable scope and methodologies to the work being performed under this Section. The Competent Person shall be on site during all mercury-related work activities.

3. Mercury worker: The Mercury Removal Company shall have on staff and assigned to this Contract a sufficient number of Mercury workers who have successfully completed DOT Hazardous Materials Transportation Training and Mercury Awareness Training courses as defined in this Section. Each training course shall have been completed within the past year in the form of either an initial course or a refresher course. In addition, each Mercury worker shall have a minimum of one (1) year of experience on projects involving mercury, and shall have worked on at least three (3) projects of comparable scope and methodologies to the work being performed under this Section.

1.08 SUBMITTALS

- A. Within 30 business days of the Notice to Proceed or as directed by the Engineer, the Contractor shall submit the following to the Engineer:
  1. Mercury Management Plan: The Contractor shall submit a detailed, project-specific Mercury management plan that addresses work procedures and equipment to be used during the disturbance, removal, construction/demolition, handling, collection, and disposal of Mercury-Containing Materials and Mercury Wastes. The Mercury management plan shall be prepared in accordance with this Section and all pertinent federal, state, and local regulations. In addition, the Mercury management plan shall follow all DEP EHS Policies and Procedures, and shall be coordinated with the Engineer. The Mercury management plan shall also be signed and dated by a CIH meeting the qualifications set forth in this Section. The Mercury management plan shall include the following elements:
    - a. Mercury Control:
      - 1) Drawings showing the locations and details of each work area and each waste storage;
      - 2) A detailed discussion regarding the interfacing of trades (i.e., how the Contractor will coordinate the Work with

- other contractors or DEP employees working at the site) and the sequencing of mercury-related Work;
- 3) A detailed discussion on the implementation of proper precaution when Mercury containing equipment (gauges, switches, flow meters, manometers, thermometers, flow regulators, laboratory equipment, lamps, etc.) is removed to prevent release of elemental mercury onto or into connected equipment or appurtenances;
  - 4) A detailed discussion on the implementation of proper precaution when Work involves removal, repair or alterations of equipment or appurtenances where known or suspected historical mercury containing equipment (gauges, switches, flow meters, manometers, thermometers, flow regulators, laboratory equipment, lamps, etc.) may have been part of the system;
  - 5) A detailed discussion regarding the collection, handling procedures, and recycling/disposal of Mercury-Containing Materials and Mercury Wastes;
  - 6) A detailed discussion regarding “real-time” air monitoring for mercury vapor (e.g., using a Jerome® meter) to be implemented during the Work, as applicable. Also, indicate what Action Levels will be used for the Work, how compliance with the Action Levels and the REL (per the DEP EHS Policy and Procedure for Mercury Management) will be determined, and who will be responsible for ensuring that compliance with the Action Levels and REL is maintained. At a minimum, Action Levels shall be established for the following situations: (a) the removal of broken/leaking Mercury-Containing Materials; (b) the implementation of engineering controls and safe work practices; (c) upgrades/downgrades in levels of PPE; (d) work stoppage or the emergency evacuation of on-site personnel;
  - 7) A detailed discussion regarding housekeeping procedures to be used for maintaining clean work areas;
  - 8) A detailed task analysis for each work activity that has the potential to disturb Mercury-Containing Materials or Mercury Wastes. Each task analysis shall include, but is not limited to, the following information: (a) the type of

work activity; (b) the tools/equipment that will be used; (c) operation and maintenance practices and procedures that will be used for the tools/equipment; (d) the types of Mercury-Containing Materials that may be disturbed, or Mercury Wastes that may be generated when performing the activity; (e) the engineering controls that will be used to control the spread of contamination during the activity; (f) the proposed crew size for the activity and individual employee responsibilities during the activity; (g) housekeeping procedures that will be used during the activity; (h) PPE that will be used for the removal of both intact and broken (leaking) Mercury-Containing Materials, and the decontamination protocol when handling removal of broken (leaking) mercury-containing equipment;

- 9) Equipment and Supplies: Identify the equipment and supplies that will be used to perform the Work;
- 10) Rental Equipment Notification: If rental equipment is to be used during the Work, the Contractor shall notify the rental agency in writing concerning the intended use of the equipment;
- 11) SDSs: Provide SDSs for all chemical products to be used during the Work.

b. Waste Management:

- 1) The identification of Mercury-Containing Materials and Mercury Wastes (as defined in 40 CFR 116, 40 CFR 260, 40 CFR 261, 6 NYCRR 370 and 6 NYCRR 371) associated with the Work;
- 2) The estimated quantity of each waste stream that will be generated and recycled/disposed of as per 40 CFR 302;
- 3) The name, address, phone number, and qualifications of each vendor and facility that will be transporting, storing, testing, or recycling/disposing of the wastes. The Contractor shall verify the permit status of the facility as well as check for outstanding violations and enforcement actions. Include a 24-hour phone contact for each vendor/facility.
- 4) Current permit documentation for each recycling facility/TSDf indicating that the facility is approved by federal (40 CFR 264 and 40 CFR 265), state (6 NYCRR

373), and local regulatory agencies to receive Mercury-Containing Materials and Mercury Wastes. The documentation shall include an “acceptance letter” from each recycling facility/TSDF indicating its ability to accept the specific waste streams that will be generated during Work performed under this Section;

- 5) Current 6 NYCRR 364 and 40 CFR 263 permit documentation for the waste transporter that will transport Mercury-Containing Materials and Mercury Wastes from the work site to the recycling facility/TSDF. The documentation shall clearly indicate the transporter’s ability to deliver the Mercury-Containing Materials and Mercury Wastes to the chosen recycling facility/TSDF;
  - 6) Spill prevention, containment, and cleanup contingency measures to be implemented during the Work, as well as procedures to be followed during a suspected mercury emissions/bulk material release or emergency situation. All measures and procedures shall be in accordance with this Section, including 15 RCNY Chapter 19;
  - 7) A detailed discussion of the on-site handling, storage, removal, and recycling/disposal of waste materials. This discussion shall include, but is not limited to, the following: (a) specifications for a secondary containment system for each drum storage area; (b) the methods of demarcation that will be used to identify the waste storage areas and each waste container; (c) the methods and procedures that will be used to collect and containerize wastes on a daily basis; (d) the types of containers that will be used to containerize the wastes; (e) the posting of weekly regulated waste inspection and inventory records as required in this Section.
- c. A detailed schedule for the implementation of the Mercury management plan elements. The schedule shall clearly indicate the starting and completion dates for the work, and shall allow adequate time for cleanup activities and inspections;
  - d. The name and qualifications (i.e., experience and training documentation) of the Competent Person who will be responsible for the oversight and execution of the Mercury management plan during activities affecting Mercury-Containing Materials and Mercury Wastes. At a minimum, the

Competent Person shall satisfy the qualification requirements of this Section.

- e. Employee Documentation: For all activities that disturb Mercury-Containing Materials and Mercury Wastes, the Contractor shall provide a sufficient number of properly trained and experienced workers, each of whom shall: (a) have written proof of training (e.g., certificates) in accordance with the qualification requirements of this Section for Mercury workers and Competent Persons that will be used for the Work; (b) copies of resumes for Mercury workers and Competent Persons that will be used for the Work, indicating work experience as required in this Section.
  - f. A current (i.e., within the last month) signed and notarized statement disclosing all of the Mercury Removal Company's OSHA, EPA, and DOT citations/violations within the past three (3) years.
- B. Field Reports and Recordkeeping: During all Work performed under this Section, the Contractor shall maintain and provide the following documentation:
- 1. Recycled Materials/Waste Documentation: Completed and signed waste manifests from recycling facilities/TSDFs shall be provided to the DEP within ten (10) business days of disposal. In addition, on-site waste storage areas shall be inspected weekly by the Competent Person, who at a minimum shall satisfy the qualification requirements of this Section.
    - a. Each weekly waste storage area inspection shall be coordinated with the applicable Bureau EHS, documented in the form of a written report, and each report shall be signed by the Contractor's employee who generated the report. All reports shall be provided to the DEP within 24-hours of the date the inspection is completed. The content of these reports shall include, but is not limited to, the following information: (a) the name of the individual that conducted the inspection; (b) descriptions of waste streams being stored; (c) types and quantities of waste containers being used; (d) the current recycling/disposal status (i.e., when the waste container is scheduled to be removed from the work site) and physical condition of each waste container; (e) the presence/absence of proper labeling for each waste container in accordance with this Section and federal, state, and local regulations; (f) secondary containment systems being used; (g) the methods being used to secure/lock each waste storage area to prevent any unauthorized entry; (i) the presence of any waste containers on site generated

during the Work being performed under this Section that violate RCRA generator storage time limitations, as defined in 40 CFR 262.

- b. In addition to performing weekly waste storage area inspections, the Competent Person shall maintain an ongoing waste inventory. The waste inventory shall be coordinated with the applicable Bureau EHS, and the content of the inventory shall include, but is not limited to, the following information: (a) specific dates that each waste container was added/removed from the waste storage area; (b) the full name (printed) and signature of the individual responsible for adding/removing each waste container from the waste storage area.
2. Mercury Work Area Inspection Documentation: Work areas shall be inspected daily by the Competent Person, who at a minimum shall satisfy the qualification requirements of this Section.
- a. Each daily work area inspection shall be documented in the form of a written report, and each report shall be signed by the Contractor's employee who generated the report. All reports shall be provided to the DEP within 24-hours of the date the inspection is completed. The content of these reports shall include, but is not limited to, the following information: (a) the types of work being performed; (b) the names of Mercury workers and the Competent Person on site, as well as the name of the company each individual is representing; (c) any non-compliance issues observed (i.e., observations that conflict with the requirements of the Contractor's Mercury management plan, this Section, DEP EHS Policies and Procedures, or federal, state, and local regulations) along with the corrective actions that were taken to achieve compliance.
3. Contractor Project Record: The Contractor's Competent Person shall maintain a project record at the work site. The Contractor Project Record shall be made available to the Engineer or DEP for review at any time during the Work, and shall be submitted to the DEP within 24-hours after the completion of the Work.
- a. At a minimum, the Contractor Project Record shall contain the following information: (a) copies of training certificates for all individuals involved with the Work; (b) copies of all Mercury-Containing Materials survey reports relating to the Work; (c) copies of all daily sign-in sheets as required in this Section; (d) a list of emergency phone numbers, including the local fire department, local police department, nearest hospital, as well as phone numbers for the Engineer and DEP personnel responsible

for administering the Work; (e) a copy of the EPA's Standard for Universal Waste Management (40 CFR 273); (f) a copy of the New York State Department of Environmental Protection's (NYSDEC's) Standards for Universal Wastes (6 NYCRR 374-3) and Mercury-Added Consumer Product's Law (Chapter 145, Laws of New York, 2004); (g) copies of all SDSs pertaining to all chemicals being used during the Work; (h) a copy of this Section and the related Drawings; (i) a copy of the Contractor's Mercury management plan; (j) copies of all daily work area inspection records; (k) copies of all weekly waste storage area inspection records; (l) a copy of the waste inventory; (m) copies of all DEP EHS Policies and Procedures referenced in this Section; (n) a copy of the Contractor's Hazard Communication (HAZCOM) program.

4. Daily Sign-In Sheets: The Contractor shall generate daily sign-in sheets for all individuals entering and exiting each work area for the duration of the Work. The daily sign-in sheets shall be maintained by the Competent Person, and shall be made available to the Engineer or DEP for review at any time during the Work. All daily sign-in sheets shall be submitted to the DEP within 24-hours after the completion of the Work.
  - a. At a minimum, each daily sign-in sheet shall include: (a) the individual's full name (printed); (b) the individual's signature; (c) the name of the company the individual is representing; (d) the time of entry and exit from the area; and (e) verification by the Competent Person that the individual meets the applicable training requirements, if the individual intends to enter a work area.
5. HAZCOM Program: The Contractor's HAZCOM program shall be made available to the Engineer or DEP for review at any time during the Work.

## PART 2 PRODUCTS

### 2.01 MATERIALS

- A. PPE: The Contractor shall provide personnel who have a potential to be exposed to Mercury-Containing Materials or Mercury Wastes, with appropriate PPE as prescribed by the Contractor's CIH.
- B. High-Efficiency Particulate Air (HEPA) Filters: HEPA/P-100 filters used in HEPA vacuuming equipment must meet or exceed any manufacturer's specifications and recommendations, as well as specifications presented in the Standard for Safety High Efficiency, Particulate, Air Filter Units (UL 586).

- C. Waste Containers: Containers for the storage of all recyclable materials and wastes shall be DOT-approved, and shall be provided by the Contractor.

**PART 3 EXECUTION**

**3.01 PREPARATION**

- A. Utilities: The temporary use of any on-site utilities shall be subject to the approval of DEP. The Contractor shall furnish all water and hoses needed for the Work, as well as any temporary hookups. Also, the Contractor shall supply all heating equipment and water filtration devices needed for the Work. In addition, all temporary lighting and temporary electrical service to a work area shall be provided by the Contractor, and shall be in weatherproof enclosures and be ground fault protected.
- B. Signs: The Contractor shall post conspicuous warning signs at all approaches to work areas and waste storage areas. The signs shall be located at such a distance so that personnel may read the sign and take the necessary precautions before entering a work area or waste storage area. Signs shall comply with federal, state, and local regulations, including the requirements of OSHA. Signs shall not be removed until all removal and construction/demolition activities have been completed. At a minimum, each sign shall bear the following information in English and the predominant language that is spoken by the Contractor's employees if English is not spoken:

**WARNING  
MERCURY WORK AREA  
POISON  
NO SMOKING OR EATING**

- C. Physical Boundary Delineation: The Contractor shall clearly delineate each work area and waste storage area with a Physical Boundary as defined in this Section.
- D. Work Area Preparation: The Contractor shall utilize HEPA-filtered vacuums, equipped with mercury filters, and wet methods during the initial cleaning of each work area. Prior to removal from each work area, all movable objects and mounted objects that can be removed shall be pre-cleaned using HEPA-vacuums and wet methods. Fixed objects that must remain within each work area shall be pre-cleaned using HEPA vacuums and wet methods, and subsequently covered with 6-mil, polyethylene sheeting. The Competent Person shall visually inspect and verify the adequacy of cleaning prior to removal of objects from the work area and/or covering with polyethylene sheeting.



3.02 REMOVAL

- A. Protection of Existing Work to Remain: All Work involving the disturbance of Mercury-Containing Materials or Mercury Wastes must be conducted without damage to, or contamination of equipment or surfaces within the work areas or other areas adjacent to the work areas. All such damage or contamination shall be immediately corrected and cleaned up by the Contractor at the Contractor's expense.
- B. Work Area Containment Measures: The Contractor shall utilize impermeable containment materials (i.e., 6-mil polyethylene sheeting) within each work area to prevent potential contamination from Mercury-Containing Materials or Mercury Wastes while performing the Work. At a minimum, the Contractor shall place 6-mil polyethylene sheeting on the floor beneath Mercury-Containing Materials that are being removed. Any containment materials that become contaminated during the Work shall not be reused, and shall be properly containerized and disposed of in accordance with this Section.

3.03 CLEANUP AND DISPOSAL

- A. Cleanup: The Contractor shall maintain all surfaces, including protective coverings (polyethylene sheeting) within each work area, free of accumulations of debris, dusts, and wastes. The Contractor shall perform housekeeping activities daily throughout each work shift and at the end of each work shift, in order to prevent any accumulation of debris, dusts, and wastes in the work areas. Using compressed air to cleanup a work area shall be strictly prohibited. HEPA-filtered vacuums and wet methods shall be used to ensure that each work area remains free of visible debris, dusts, and wastes.
- B. Collection, Separation, and Containerization of Wastes: The Contractor shall collect, separate (by waste stream/waste type), and containerize Mercury Wastes (solid and liquid), debris, PPE, and containment materials on a daily basis in accordance with the Mercury management plan.
  - 1. The Contractor shall store all wastes in DOT-approved container systems. No drum/container shall be filled in excess of the capacity marked on the drum/container. All drums/containers shall be sealed and covered immediately after filling, and each drum/container will have a label affixed to it in accordance with this Article. All labels shall remain intact and legible at all times.
  - 2. No water mixed with or contaminated by mercury may be released onto the ground or into any drain or sewer. It should be noted that a discharge of more than 1 lb. of mercury onto the ground or into the water within a 24-hour period, shall be considered a violation of the Clean Water Act and shall be treated as a "reportable quantity" in accordance with 40 CFR 117. Such a release shall be grounds for immediate termination of

## GENERAL SPECIFICATION 13282 - MERCURY MANAGEMENT

---

this Contract and the Contractor shall be liable for any fines, penalties, or remediation costs.

3. Any quantity of elemental mercury that is released or spilled must be immediately reported to DEP. Reporting to NYSDEC Spill Hotline is required for a release of one pound (approximately two tablespoons) or more.
  4. The Contractor shall store non-mercury-containing wastes separately from mercury-containing wastes, shall provide all non-mercury-containing waste containers, and shall make all transportation and disposal arrangements for non-mercury-containing wastes in accordance with federal, state, and local regulations.
- C. **Storage of Wastes:** The Contractor shall ensure that all drummed wastes are stored in a secondary containment system, and that each waste storage area is demarcated with a Physical Boundary in accordance with this Section. In addition, the Contractor shall post weekly waste inspections and waste inventories in the hazardous waste storage area, as defined in this Section, as well as the following emergency information in accordance with DEP's EHS Policies and Procedures: (a) the name and telephone number of the facility's Emergency Coordinator; (b) the location of fire extinguishers and fire alarms; (c) the location of spill control materials; (d) the telephone number for the fire department (unless the facility has a direct alarm).
- D. **Labeling:** The Contractor shall affix warning labels to all mercury recycling/waste drums and containers. Labels shall comply with the requirements of federal, state, and local regulations, including EPA and DOT requirements. At a minimum, all labels shall bear the following information in English:

<p style="text-align: center;"><b>[Generator Name, Address, and Telephone Number]</b> <b>[Specific Contents of Container]</b> <b>[Accumulation Start Date]</b> <b>[Accumulation End Date]</b></p>
---

1. If necessary (i.e., if waste is to be disposed of as hazardous waste rather than Universal Waste), also include the following information on the label:

**HAZARDOUS WASTE  
FEDERAL LAW PROHIBITS IMPROPER  
DISPOSAL  
HANDLE WITH CARE  
[EPA-Issued Generator Identification Number]  
[EPA Waste Identification Number]**

- E. Characterization and Disposal of Wastes: Mercury-Containing Materials to be removed under the Work of this Section shall be recycled in accordance with the EPA’s Standards for Universal Waste Management (40 CFR 273), the NYSDEC’s Standards for Universal Wastes (6 NYCRR 374-3), and the NYSDEC’s Mercury-Added Consumer Products Law (Chapter 145, Laws of New York, 2004). If a material is not regulated as a Universal Waste, the material shall be considered a hazardous waste, and shall be disposed of in accordance with RCRA requirements.
1. All waste profiles for containerized wastes must be reviewed by the Engineer and signed by DEP as the generator of the waste streams. The Contractor shall notify DEP at least 14 days prior to the removal of any waste drums/containers, so that DEP can inspect the drums/containers and review and approve advance copies of all waste manifests. Hazardous wastes shall be disposed of to ensure that drums/containers do not remain on the job site for more than 90 calendar days from the initial “accumulation start date” on the label affixed to the drum/container. Universal Wastes shall be disposed of to ensure that drums/containers do not remain on the job site for more than one (1) year from the initial “accumulation start date” on the label affixed to the drum/container. Containers that have reached their storage capacity shall not remain on site and transportation arrangements shall be made for their immediate removal.
- F. Disposal Documentation: The Contractor shall submit written evidence that the recycling facility/TSDF receiving Mercury-Containing Materials or Mercury Wastes is approved by federal, state, and local regulatory agencies to receive the materials/wastes. Once all waste profiles have been completed, the Contractor shall provide DEP with a “Letter of Acceptance” issued by the TSDF indicating that the wastes will be accepted. On the date of disposal, the Contractor shall submit one (1) copy of the completed manifest, that has been signed and dated by the initial transporter in accordance with 6 NYCRR 372 and 40 CFR 262, to the DEP for signature as Generator. All waste profiles, manifests, and Land Disposal Restrictions (LDRs) per 6 NYCRR 376 and 40 CFR 268 must be signed by a DEP employee per Section 01355 – Hazardous Materials Control.

END OF SECTION

NO TEXT ON THIS PAGE

# GENERAL SPECIFICATION 13283 - LEAD MANAGEMENT

---

## SECTION 13283 Lead Management

### PART 1 GENERAL

#### 1.01 SUMMARY

- A. This Section details the requirements for construction and demolition activities affecting materials and structures coated with or containing Lead or other heavy metals as shown on the Drawings, specified herein, or required to complete the Work, including all affected coatings identified and impacted by the Work. All Work to be performed under this Section shall be performed using methods, tools, and equipment that have demonstrated effectiveness in preventing airborne emissions from migrating outside of Work areas.
  - 1. Coated material and structures may contain other heavy metals in addition to Lead. Where Lead is discussed in this Section the Contractor shall consider other heavy metals (i.e., arsenic, cadmium, chromium, etc.)
- B. All Work under this Section shall be performed to minimize the creation of airborne emissions (40 CFR 50); minimize the quantity of hazardous waste generated; protect the health and safety of all site personnel and the welfare of the public; and avoid adverse environmental impacts.
- C. Unless otherwise specified, the Work of this Section shall also be performed in accordance with the most current New York City Department of Environmental Protection (DEP) Environmental Health and Safety (EHS) Policies and Procedures (including Lead Management, Hazardous Waste Management, and Spill Prevention, Environmental Release Reporting and Investigation), and applicable federal, state, and local regulations.
- D. In the absence of analytical testing results for a specific painted/coated material, air monitoring and worker Personal Protective Equipment (PPE) requirements, including respiratory protection, shall address the potential presence of PCBs, Lead and heavy metals. Any unforeseen PCB or heavy metal-containing paints/coatings discovered during the Work to be performed under this Section shall be remediated as necessary to complete the Work in accordance with this Section.
- E. The Contractor shall perform all Work under this Section without damaging or contaminating adjacent areas to where the Work is being performed. Where such areas are damaged or contaminated, as determined by the DEP, the Contractor shall restore the areas to their original condition at no additional cost to the DEP.
- F. The following index of this section is presented for convenience:

# GENERAL SPECIFICATION 13283 - LEAD MANAGEMENT

---

<u>Article</u>	<u>Title</u>	<u>Page</u>
		13283-
PART 1	GENERAL .....	1
1.01	Summary .....	1
1.02	Payment.....	2
1.03	Related Sections.....	2
1.04	Reference Standards.....	3
1.05	Definitions.....	5
1.06	Special Requirements.....	12
1.07	Quality Assurance.....	13
1.08	Submittals .....	16
PART 2	PRODUCTS.....	24
2.01	Materials .....	24
PART 3	EXECUTION.....	25
3.01	Preparation .....	25
3.02	Air Monitoring .....	27
3.03	Bulk Removal .....	28
3.04	Cleanup and Disposal .....	30
1.02	PAYMENT	
A.	Except for unforeseen lead-containing materials and related work eligible for payment under allowance, as described in Section 01355– Hazardous Materials Control, no separate payment will be made for performing any work required under this Section and the Contractor shall include all costs thereof in its prices bid for the Contract.	
B.	Payment for remediation of unforeseen lead-containing materials, including the removal and disposal of lead paint, will be made under allowance as specified in Section 01270 – Measurement and Payment.	
C.	Payment for the disposal of lead wastes (with the exception of painted/coated scrap metal) will not be made until a signed copy of the manifest from the Treatment, Storage, and Disposal Facility (TSDF), certifying the amount of lead wastes delivered is returned with complete chain-of-custody (COC) documentation to the NYCDEP.	
1.03	RELATED SECTIONS	
A.	Section 01270 -- Measurement and Payment	
B.	Section 01356 -- Environmental Health and Safety Requirements	
C.	Section 01355 – Hazardous Materials Control	
D.	Section 13284 -- PCBs Management	

## GENERAL SPECIFICATION 13283 - LEAD MANAGEMENT

---

### 1.04 REFERENCE STANDARDS

- A. The Contractor shall comply with all applicable regulations, standards, and guidelines of federal, state, and local environmental and occupational safety and health agencies regarding Lead-Containing Materials and Lead Wastes. These regulations, standards, and guidelines include, but are not limited to the following:
1. United States (U.S.) Department of Transportation (DOT):
    - a. 49 CFR 171 - General Information, Regulations, and Definitions;
    - b. 49 CFR 172 – Hazardous Materials Table, Special Provisions, Hazardous Materials Communications, Emergency Response Information, and Training Requirements;
    - c. 49 CFR 173 – Shippers: General Requirements for Shipments and Packaging’s;
    - d. 49 CFR 178 – Specifications for Packaging’s.
  2. United States Environmental Protection Agency (EPA):
    - a. 40 CFR 50 – National Primary and Secondary Ambient Air Quality Standards;
    - b. 40 CFR 116 – Designation of Hazardous Substances;
    - c. 40 CFR 117 – Determination of Reportable Quantities for Hazardous Substances;
    - d. 40 CFR 260 – Hazardous Waste Management Systems: General;
    - e. 40 CFR 261 – Identification and Listing of Hazardous Waste;
    - f. 40 CFR 262 – Standards Applicable to Generators of Hazardous Waste;
    - g. 40 CFR 263 – Standards Applicable to Transporters of Hazardous Waste;
    - h. 40 CFR 264 – Standards for Owners and Operators of Hazardous Waste Treatment, Storage, and Disposal Facilities;
    - i. 40 CFR 265 – Interim Status Standards for Owners and Operators of Hazardous Waste Treatment, Storage, and Disposal Facilities;
    - j. 40 CFR 268 – Land Disposal Restrictions;
    - k. 40 CFR 302 – Designation, Reportable Quantities, and Notification;

## GENERAL SPECIFICATION 13283 - LEAD MANAGEMENT

---

1. 40 CFR 745 – Lead-Based Paint Poisoning Prevention in Certain Residential Structures.
3. National Institute for Occupational Safety and Health (NIOSH):
  - a. Method 5503 – Polychlorobiphenyls;
  - b. Method 7048 – Cadmium and Compounds, as Cd;
  - c. Method 7082 – Lead by FAAS;
  - d. Method 7105 – Lead by GFAAS;
  - e. Method 7300 – Elements by ICP;
  - f. Method 7600 – Chromium, Hexavalent;
  - g. Method 7604 – Chromium, Hexavalent;
  - h. Method 7900 – Arsenic and Compounds, as;
  - i. NIOSH Pocket Guide to Chemical Hazards.
4. DEP:
  - a. Environmental Health and Safety Policies and Procedures – Vol. III, Lead Management;
  - b. Environmental Health and Safety Policies and Procedures – Vol. IV, Hazardous Waste Management;
  - c. RCNY Title 15, Chapter 19 – Discharges of Wastewater and Other Materials to Public Sewers.
5. New York State Department of Environmental Conservation (NYSDEC):
  - a. 6 NYCRR 364 – Waste Transporter Permits;
  - b. 6 NYCRR 370 – Hazardous Waste Management Regulations;
  - c. 6 NYCRR 371 – Identification and Listing of Hazardous Waste;
  - d. 6 NYCRR 372 – Hazardous Waste Manifest System and Related Standards for Generators, Transporters, and Facilities;
  - e. 6 NYCRR 373 – Hazardous Waste Management Facilities;
  - f. 6 NYCRR 376 – Land Disposal Restrictions.
6. Occupational Safety and Health Administration (OSHA):
  - a. 29 CFR 1910 – Occupational Safety and Health Standards;
  - b. 29 CFR 1910.28 – Safety Requirements for Scaffolding;
  - c. 29 CFR 1910.120 – Hazardous Waste Operations and Emergency Response;



## GENERAL SPECIFICATION 13283 - LEAD MANAGEMENT

---

- d. 29 CFR 1910.134 – Respiratory Protection Standard;
  - e. 29 CFR 1910.1200 - Hazard Communication Standard;
  - f. 29 CFR 1926 – Safety and Health Regulations for Construction;
  - g. 29 CFR 1926.62 – Lead in Construction Standard;
  - h. 29 CFR 1926.1118 – Inorganic Arsenic in Construction Standard;
  - i. 29 CFR 1926.1126– Hexavalent Chromium in Construction Standard
  - j. 29 CFR 1926.1127 – Cadmium in Construction Standard.
7. Society for Protective Coatings (SSPC):
- a. SSPC-Guide 6, Guide for Containing Debris Generated During Paint Removal Operations;
  - b. SSPC-Guide 7, Guide for the Disposal of Lead-Contaminated Surface Preparation Debris;
  - c. SSPC-SP COM, Surface Preparation Commentary for Steel and Concrete Substrates;
  - d. SSPC-SP 1, Solvent Cleaning;
  - e. SSPC-SP 2, Hand Tool Cleaning;
  - f. SSPC-SP 3, Power Tool Cleaning;
  - g. SSPC-SP 11, Power Tool Cleaning to Bare Metal;
  - h. SSPC-SP 13/ NACE No.6, Surface Preparation of Concrete;
  - i. SSPC-SP 15, Commercial Grade Power Tool Cleaning.
8. Underwriters Laboratories, Inc. (UL):
- a. UL 586 – Standard for Safety High Efficiency, Particulate, Air Filter Units.

### 1.05 DEFINITIONS

- A. Abatement: Defined by the EPA (40 CFR 745.223) as any measures or set of measures designed to permanently eliminate Lead Paint hazards. Abatement includes, but is not limited to, the removal of Lead Paint and dust, the permanent enclosure or encapsulation of Lead Paint, or the replacement of Lead-painted surfaces or fixtures. Abatement does not include renovation, remodeling, landscaping, or other activities, when such activities are not designed to permanently eliminate Lead Paint hazards, but instead, are designed to repair, restore, or remodel a given structure or dwelling, even though these activities may incidentally result in a reduction or elimination of Lead Paint hazards.

## GENERAL SPECIFICATION 13283 - LEAD MANAGEMENT

---

- Furthermore, Abatement does not include interim controls (e.g., the spot removal of Lead Paint on a surface in order to perform torch cutting at that location), operations and maintenance activities, or other measures and activities designed to temporarily, but not permanently, reduce Lead Paint hazards.
- B. **Action Level:** Defined by OSHA as individual exposure, without regard to the use of respirators, to a specific airborne concentration of a contaminant expressed in micrograms per cubic meter of air ( $\mu\text{g}/\text{m}^3$ ) calculated as an 8-hour Time-Weighted Average (TWA). Once an Action Level is met or exceeded, the Contractor is responsible for meeting specific requirements outlined in the applicable OSHA standard, which may include additional worker Exposure Monitoring, the use of PPE including respiratory protection, the use of Hygiene Facilities, medical surveillance, or training for workers. The following Action Levels are pertinent to the disturbance, removal, construction/demolition, and disposal activities associated with painted/coated materials and structures: (a) cadmium –  $2.5 \mu\text{g}/\text{m}^3$  per 29 CFR 1926.1127; (b) hexavalent chromium -  $2.5 \mu\text{g}/\text{m}^3$  per 29 CFR 1926.1126; (c) inorganic arsenic -  $5 \mu\text{g}/\text{m}^3$  per 29 CFR 1926.1118; (d) Lead -  $30 \mu\text{g}/\text{m}^3$  per 29 CFR 1926.62.
- C. **Area Monitoring:** Stationary air sampling outside of a Lead Control Area for the purpose of determining compliance with OSHA’s Lead in Construction Standard (29 CFR 1926.62), and for the purpose of ensuring that airborne Lead concentrations remain below  $30 \mu\text{g}/\text{m}^3$  outside of the Lead Control Area during all work activities that have the potential to disturb Lead-Containing Materials or Lead Wastes. Area Monitoring for PCBs or other heavy metals will be required if Exposure Monitoring results exceed corresponding Action Levels, Permissible Exposure Limits (PELs), or Recommended Exposure Limits (RELs). All Area Monitoring shall follow pertinent NIOSH (Methods 5503, 7048, 7082, 7105, 7300, 7600, 7604, 7900) or ASTM sampling methodologies.
- D. **C-3/C-5 Supervisor Competent Person Training for Deleading of Industrial Structures:** A training course administered by the SSPC or a company that has been approved by the SSPC as a “trainer,” which includes discussions of the following: (a) background information on Lead and other toxic metals; (b) a legal and regulatory overview; (c) worker protection from Lead and other toxic metals; (d) compliance with air, soil, water, sediment, and dust regulations; (e) management of solid and hazardous wastes; (f) sources of Lead exposure; (g) control of environmental releases; (h) specifications and Site-specific compliance plans; (i) Work Site preparation; (j) insurance and bonding issues; (k) other safety and health hazards.
- E. **Certified Industrial Hygienist (CIH):** Refers to an individual employed by the Contractor who is currently certified by the American Board of Industrial Hygiene (ABIH).

## GENERAL SPECIFICATION 13283 - LEAD MANAGEMENT

---

- F. **Competent Person:** Defined in the OSHA Lead in Construction Standard (29 CFR 1926.62) as one who is capable of identifying existing and predictable hazards in the surroundings or working conditions, and who has authorization to take prompt corrective measures to eliminate them. Duties of the Competent Person include the following: (a) determining prior to the performance of the Work, whether Lead, PCBs, or other heavy metals are present in the workplace; (b) establishing Lead Control Areas and assuring that access to and from those areas is limited to authorized personnel; (c) assuring the adequacy of any employee Exposure Monitoring required by OSHA; (d) assuring that all employees exposed to airborne contaminant levels above Action Levels, PELs, or RELs wear appropriate PPE, respiratory protection, and are trained in the use of appropriate methods of exposure control for all of the contaminants present; (e) assuring that proper Hygiene Facilities are provided and that workers are trained to use those facilities; (f) assuring that engineering controls specific to the contaminants present are implemented, maintained in proper operating condition, and functioning properly.
- G. **Decontamination Area:** Designated area within the Hygiene Facilities for removing gross contamination from PPE (using a HEPA vacuum), washing away contamination that has accumulated on the skin and hair (using soap and water), removing and disposing/washing of contaminated PPE, and donning clean clothing that will not potentially contaminate areas outside of a Lead Control Area's Physical Boundary.
- H. **DOT Hazardous Materials Transportation Training:** Training that meets the criteria outlined in 49 CFR 172.704. This training shall include discussions from 49 CFR 171 of the following: (a) hazardous materials tables within 49 CFR 172; (b) material packaging and labeling within 49 CFR 178; (c) shipping papers and placards within 49 CFR 173; (d) material loading and segregation within 49 CFR 173.
- I. **Exclusion Zone:** (See definition of "Lead Control Area").
- J. **Exposure Monitoring:** Personal air sampling performed outside the respirator within the breathing zone of individuals, for the purpose of determining compliance with OSHA's Limits for Air Contaminants Table (29 CFR 1910.1000, Table Z-1), OSHA's Cadmium in Construction Standard (29 CFR 1926.1127), Hexavalent Chromium in Construction Standard (29 CFR 1926.1126), Inorganic Arsenic in Construction Standard (29 CFR 1926.1118), and Lead in Construction Standard (29 CFR 1926.62). Analytical results obtained from Exposure Monitoring will be used to select appropriate respiratory protection and PPE for individuals within a work area. For the purpose of this Section, Exposure Monitoring samples shall be collected from individuals who are representative of each type work task being conducted by the Contractor, and all Exposure Monitoring shall follow pertinent NIOSH or ASTM sampling methodologies.

## GENERAL SPECIFICATION 13283 - LEAD MANAGEMENT

---

- K. Hazardous Waste Operations (HAZWOPER) Training: Training that meets the criteria outlined in the OSHA Hazardous Waste Operations and Emergency Response Standard (29 CFR 1910.120). A minimum of 24-hour HAZWOPER Training will be required for abatement work being performed under this Section. However, certain types of work may require 40-hour HAZWOPER Training. All decisions regarding the specific HAZWOPER Training that will be required for each work task shall be made by the Engineer.
- L. High-Efficiency Particulate Air (HEPA) Filter: A filter designed to remove 99.97% of all particles greater than 0.3 micrometers ( $\mu\text{m}$ ) in diameter. For the purpose of this Section, HEPA vacuum and local exhaust filtration equipment used by the Contractor shall meet the Standard for Safety High-Efficiency, Particulate, Air Filter Units (UL 586) developed by Underwriters Laboratories.
- M. Homogenous Materials: Lead-Containing Materials which are similar in appearance, color, texture, and substrate type.
- N. Hygiene Facilities: Facilities within the Physical Boundary of a work area that are set up to prevent cross contamination and are equipped with change areas and separate storage facilities for PPE and clean clothing. Hygiene Facilities shall include adequately supplied hand washing station(s) (i.e., running water, soap, and clean towels) or shower(s) (hot and cold water that is controllable at the tap, soap, shampoo, and clean towels).
- O. Lead: Defined in the OSHA Lead in Construction Standard (29 CFR 1926.62) as metallic Lead, all inorganic Lead compounds, and organic Lead soaps. Excluded from this definition are all other organic Lead compounds.
- P. Lead Awareness Training: Training that meets the criteria outlined in the OSHA Lead in Construction Standard (29 CFR 1926.62) for individuals that have the potential to be exposed to Lead-Containing Materials or Lead Wastes. This training shall include discussions of the following: (a) current federal, state, and local regulations pertaining to Lead (including 29 CFR 1926.62) and other heavy metals that may be disturbed during the Work; (b) the health effects of Lead and other heavy metal exposure; (c) state-of-the-art work practices, engineering controls, and procedures for Abatement, removal, construction/demolition, materials handling, waste management, and housekeeping activities that involve Lead-Containing Materials and Lead Wastes; (d) the use and maintenance of PPE and the use and maintenance of respirators in accordance with 29 CFR 1910.134; (e) medical surveillance programs and the medical removal protection program; (f) requirements regarding warning signs, labeling, and Safety Data Sheets (SDSs) in accordance with 29 CFR 1910.1200; (g) responsibilities of the Competent Person.
- Q. Lead-Based Paint (LBP): A term used by Department of Housing and Urban Development (HUD) and the EPA to define paint or other surface coatings (e.g., glazes) with Lead levels equal to or exceeding 1.0 milligram per square

## GENERAL SPECIFICATION 13283 - LEAD MANAGEMENT

---

centimeter (1.0 mg/cm<sup>2</sup>) or 0.5 % by dry weight. LBP is subject to the requirements set forth in the OSHA Lead in Construction Standard (29 CFR 1926.62). In the absence of analytical testing, LBP shall be considered PCB and heavy metal-containing.

- R. Lead-Containing Material: Any material that contains, or is coated with, a detectable concentration of Lead. In the absence of analytical testing, a Lead-Containing Material shall be considered PCB and heavy metal-containing.
- S. Lead-Containing Paint (LCP): A term used to define paint or other surface coatings (e.g., glazes) with any detectable amount of Lead less than 1.0 milligram per square centimeter (1.0 mg/cm<sup>2</sup>) or 0.5 % by dry weight. LCP is subject to the requirements set forth in the OSHA Lead in Construction Standard (29 CFR 1926.62). In the absence of analytical testing, LCP shall be considered PCB and heavy metal-containing.
- T. Lead Control Area: The area within the Physical Boundary where worker Hygiene Facilities are located and where all Work activities take place that involve the disturbance of Lead-Containing Materials and Lead Wastes.
- U. Lead Paint: A generic term that refers to both LBP and LCP.
- V. Lead Waste: Non-specific liquid or solid waste generated during the Abatement, removal, construction/demolition, handling, or cleanup of a Lead-Containing Material.
- W. Organic Vapor Cartridge: A NIOSH approved respirator filter typically containing 25 to 40 grams of sorption media such as activated charcoal.
- X. OSHA Cadmium in Construction Standard (29 CFR 1926.1127): A federal standard that applies to all construction work where an employee may be occupationally exposed to cadmium. In this standard, “construction work” is defined as work involving construction, alteration, or repair, including, but not limited to, the following: (a) wrecking, demolition, or salvage of structures where cadmium or materials containing cadmium are present; (b) the use of cadmium-containing paints, and cutting, brazing, burning, grinding, or welding on surfaces that were painted with cadmium-containing paints; (c) construction, alteration, repair, maintenance, or renovation of structures, substrates, or portions thereof, that contain cadmium, or materials containing cadmium; (d) cadmium welding, cutting and welding cadmium-plated steel, brazing or welding with cadmium alloys; (e) the installation of products containing cadmium; (f) electrical grounding with cadmium welding, or electrical work using cadmium-coated conduit; (g) maintaining or retrofitting cadmium-coated equipment; (h) cadmium contamination/emergency cleanup; (i) transportation, disposal, storage, or containment of cadmium or materials containing cadmium on the site or location at which construction activities are performed.

## GENERAL SPECIFICATION 13283 - LEAD MANAGEMENT

---

- Y. OSHA Hexavalent Chromium in Construction Standard (29 CFR 1926.1126): A federal standard that applies to occupational exposures to chromium (VI) in all forms and compounds in construction except the following: (a) exposures that occur in the application of pesticides regulated by the EPA or another federal government agency (e.g., the treatment of wood with preservatives); (b) exposures to Portland cement; (c) exposures where the employer has objective data demonstrating that a material containing chromium or a specific process, operation, or activity involving chromium cannot release dusts, fumes, or mists of chromium (VI) in concentrations at or above the PEL of 5 µg/m<sup>3</sup> as an 8-hour TWA under any expected conditions of use.
- Z. OSHA Inorganic Arsenic in Construction Standard (29 CFR 1926.1118): A federal standard that applies to all occupational exposures to inorganic arsenic except the following: (a) employee exposures in agriculture; (b) exposures resulting from pesticide application; (c) exposures resulting from the treatment of wood with preservatives or the utilization of arsenic-preserved wood.
- AA. OSHA Lead in Construction Standard (29 CFR 1926.62): A federal standard that applies to all construction work where an employee may be occupationally exposed to Lead. In this standard, “construction work” is defined as work for construction, alteration, or repair, including painting and decorating. It also includes, but is not limited to, the following: (a) the demolition or salvage of structures where Lead or materials containing Lead are present; (b) the removal or encapsulation of materials containing Lead; (c) new construction, alteration, repair, or renovation of structures, substrates, or portions thereof, that contain Lead, or materials containing Lead; (d) the installation of products containing Lead; (e) Lead contamination/emergency cleanup; (f) the transportation, disposal, storage, or containment of Lead or materials containing Lead on the site or location at which construction activities are performed; (g) maintenance operations associated with any of the construction activities described in this definition.
- BB. OSHA Monitoring: (See definition of “Exposure Monitoring”).
- CC. P-100 Filter: (See definition of: “High-Efficiency Particulate Air (HEPA) Filter”).
- DD. Perimeter Monitoring: (See definition of “Area Monitoring”).
- EE. PEL: Defined by OSHA as employee exposure, without regard to the use of respirators, to a specific airborne concentration of a contaminant expressed in micrograms per cubic meter of air (µg/m<sup>3</sup>) calculated as an 8-hour TWA. Once a PEL is met or exceeded for a particular contaminant, the Contractor is responsible for meeting specific requirements outlined in the applicable OSHA standard, which may include worker Exposure Monitoring, the use of PPE including respiratory protection, the use of Hygiene Facilities, medical surveillance, or training for workers. The following PELs are pertinent to

## GENERAL SPECIFICATION 13283 - LEAD MANAGEMENT

---

- removal, demolition, and disposal activities associated with Lead-Containing Materials and Lead Wastes: (a) cadmium – 5 µg/m<sup>3</sup> per 29 CFR 1926.1127; (b) hexavalent chromium - 5 µg/m<sup>3</sup> per 29 CFR 1926.1126; (c) inorganic arsenic - 10 µg/m<sup>3</sup> per 29 CFR 1926.1118; (d) Lead - 50 µg/m<sup>3</sup> per 29 CFR 1926.62.
- FF. Personal Monitoring: (See definition of “Exposure Monitoring”).
- GG. Physical Boundary: A physical barrier designated with ropes, “caution tape,” or a partition that surrounds a work area in order to limit the entry of unauthorized personnel and delineate “clean areas” from areas that may meet or exceed an Action Level, PEL, or REL.
- HH. Recommended Exposure Limit (REL): An exposure limit recommended by the NIOSH that can be expressed as a TWA, Ceiling Limit, or Short-Term Exposure Limit (STEL). Once an REL is met or exceeded for a particular contaminant, the Contractor is responsible for ensuring that workers receive appropriate Exposure Monitoring, PPE, including respiratory protection, Hygiene Facilities, medical surveillance, and training.
- II. Regulated Area: (See definition of “Lead Control Area”).
- JJ. Resource Conservation and Recovery Act (RCRA) Training: Training that meets the criteria outlined in 40 CFR 265.16. This Training shall include Site-specific discussions of the following: (a) hazardous waste identification; (b) waste storage container use and labeling; (c) waste storage area management; (d) personal health and safety, including fire safety; (e) manifesting and the off-site transportation of wastes; (f) procedures for using, inspecting, repairing, and replacing emergency equipment and monitoring equipment; (g) procedures for communicating with other employees and outside emergency response personnel; (h) responses to fires or explosions; (i) responses to leaks, spills, and potential groundwater contamination incidents ; (j) the shutdown of operations.
- KK. TWA: The average time over a given work period (e.g., an 8-hour workday) of a person’s exposure to a chemical or agent. The average is determined by sampling for the chemical or agent throughout the time period.
- LL. Trigger Activities: Certain activities that involve a disturbance of Lead-Containing Materials or Lead Wastes. Depending upon whether the performance of these activities exceeds an Action Level, PEL, or REL, the requirements may include additional worker Exposure Monitoring, the use of PPE including respiratory protection, the use of Hygiene Facilities, medical surveillance, or training for workers. Examples of Trigger Activities include, but are not limited to, the following: abrasive blasting, welding, torch cutting/burning, heat gun usage, needle gunning/scaling, rivet busting, using a rotopeen, mechanical sanding/grinding, using mechanical shears, hand scraping/sanding, chemical stripping, and the manual demolition of Lead-Containing Materials.

## GENERAL SPECIFICATION 13283 - LEAD MANAGEMENT

---

- MM. X-Ray Fluorescence (XRF): An analytical method that can be used in the field for determining the Lead content of paints/coatings on a building component or material surface.

### 1.06 SPECIAL REQUIREMENTS

- A. Commencement of Work: Five (5) business days prior to the proposed start of the Work required under this Section at each separate location, the Contractor shall notify the Engineer and the onsite safety staff. No Work may proceed at any location until authorized by the Engineer.
- B. The Contractor shall coordinate any required equipment shutdowns with the Engineer prior to starting the Work.
- C. Access Restrictions: The Contractor shall inform the Engineer of proposed access restrictions (i.e., areas or items of equipment which will not be accessible during the proposed work), and provide estimated time frames (including specific dates) of such proposed access restrictions. The Contractor shall be aware that other contractors may be at any of the Work sites associated with this Contract. As a result, the Contractor shall not have exclusive rights to any Work Site, and shall fully cooperate and coordinate this Work with the work of other contractors who may be on Site. Therefore, the Contractor shall notify other contractors in advance of the disturbance, Abatement, removal, construction/demolition, and disposal Work included herein, to provide them with sufficient time for coordination of interrelated items that are included in their contracts and that must be performed before, after, or in conjunction with the Work included under this Section.
- D. Unexpected Entry into a Lead Control Area: In the event that DEP personnel must enter a Lead Control Area for reasons unrelated to the supervision or inspection of Work being performed under this Section (e.g., under emergency conditions), the Contractor shall immediately stop work and cleanup any loose debris, so as to permit the safe entry by DEP personnel. Any disturbance of paints/coatings, dusts, materials, or wastes that may potentially generate airborne concentrations of contaminants equal to or above an OSHA Action Level shall not proceed until all DEP personnel have exited from the Lead Control Area.
- E. Meetings: The Contractor shall visit and investigate the Site, review the Drawings, review this Section, review DEP EHS Policies and Procedures, and become familiar with any conditions which may affect the Work, as part of the pre-construction meeting and Site walk-through. The Contractor shall hold all meetings with appropriate parties as scheduled and as otherwise necessary to accomplish the Work to be performed under this Section. In addition to the pre-construction meeting and Site walk-through, other meetings may be required or may be requested by the Engineer, including briefings with Site operations personnel. Written documentation (i.e., “minutes”) of all meetings shall be



## GENERAL SPECIFICATION 13283 - LEAD MANAGEMENT

---

generated by the Contractor, and copies shall be provided to the DEP within three (3) business days following each meeting.

- F. Payment for the disposal of Lead Wastes (with the exception of painted/coated scrap metal) will not be made until a signed copy of the manifest from the TSDF, certifying the amount of Lead Wastes delivered is returned with complete COC documentation to the DEP.

### 1.07 QUALITY ASSURANCE

- A. **Scheduling:** The Contractor shall coordinate and schedule all phases of the Work to be performed under this Section with the DEP, subcontractors, material suppliers, and other parties as necessary to ensure the proper execution of the Work.
- B. **Compliance:** In addition to the detailed requirements of this Section and DEP EHS Policies and Procedures, the Contractor shall comply with all applicable regulations of federal, state, and local authorities pertaining to the disturbance, Abatement, removal, construction/demolition, handling, storage, transportation, and disposal of Lead-Containing Materials and Lead Wastes. All matters regarding the interpretation of any regulations, standards, or policies shall be submitted to the Engineer for resolution before starting the Work. Where the requirements of this Section, DEP EHS Policies and Procedures, or federal, state, or local regulations conflict or vary, the most stringent requirements or regulations shall apply.
- C. **Rejection of Non-Complying Items:** The DEP reserves the right to reject items incorporated into the Work which fail to meet the specified minimum requirements. The DEP also reserves the right to reject Contractor submittal items that are deemed inappropriate or unacceptable by the Engineer or DEP. Submittal items that may be deemed inappropriate or unacceptable include proposed vendors or subcontractors with previous regulatory citations/violations. The DEP further reserves the right, and without prejudice to other recourse, to accept non-complying items subject to an adjustment in the Contract amount, as approved by the DEP.
- D. **Suspect Material Characterization:** In order to classify a paint or coating as non-PCB or non-heavy metal containing, a paint chip/coating sample or an XRF reading must be collected. The bulk samples shall be sent to an analytical laboratory meeting the requirements of this Section.
  - 1. **Suspect PCB or Heavy Metal-Containing Paints:** Although there are no certification requirements pertaining to an individual that collects paint chip/coating samples in an industrial or commercial setting, this Section requires paint chip/coating sampling to be performed by an individual who has successfully completed a PCB awareness course and HAZWOPER Training course (as defined in this Section) within the past year. In addition, the individual shall possess a current EPA Lead

## GENERAL SPECIFICATION 13283 - LEAD MANAGEMENT

---

Inspector or EPA Risk Assessor certification, or shall have successfully completed a Lead Awareness Training course (within the past year) as defined in this Section and have documented experience in collecting paint chip samples.

2. The qualifications of individuals who will collect paint chip/coating samples or XRF readings must be approved by the Engineer prior to sample/reading collection. Analytical results for paint chip/coating samples or XRF readings that are collected by individuals not approved by the Engineer will not be recognized or accepted as valid by the DEP.

E. Qualifications:

1. The Paint Removal Company shall have successfully completed at least two (2) projects of comparable scope and methodologies to the Work being performed under this Section within the past three (3) years. This experience shall be documented by identifying the following: (a) the name, address, and phone number of each facility where the Work was performed; (b) the name of the individual representing the owner who supervised the work at each facility; (c) the types of facilities where the work was performed; (d) the volume and type of each material that was abated/removed; (e) the specific methods of Abatement/removal used at each facility (including the tools, technologies, and engineering controls employed).
2. Competent Person: The Contractor shall have on staff and assigned to this Contract a Competent Person who has successfully completed DOT Hazardous Materials Transportation Training and RCRA Training courses as defined in this Section. In addition, the Competent Person shall have successfully completed both HAZWOPER Training and Lead Awareness Training courses as defined in this Section, or C-3/C-5 Supervisor Competent Person Training for Deleading of Industrial Structures as defined in this Section, or training as an EPA Lead Supervisor in accordance with 40 CFR 745.225 (b)(7)(vi). Each training course shall have been completed within the past year in the form of either an initial course or a refresher course. In addition, the Competent Person shall be able to fulfill the duties defined in this Section, and have a minimum of two (2) years' experience on projects involving Lead, and has served as the Competent Person on at least three (3) projects of comparable scope and methodologies to the work being conducted under this Section.
  - a. DEP EHS Policies and Procedures require EPA-certified Lead Training for all Lead Abatement activities. HAZWOPER and Lead Awareness Training or C-3/C-5 Supervisor Competent Person Training satisfies the training requirement for all other

## GENERAL SPECIFICATION 13283 - LEAD MANAGEMENT

---

Lead removal activities (e.g., spot removal and demolition work).

3. **Waste Manager:** The Contractor shall have on staff and assigned to this Contract a waste manager who has successfully completed DOT Hazardous Materials Transportation Training, HAZWOPER Training, Lead Awareness Training, and RCRA Training courses as defined in this Section. Each training course shall have been completed within the past year in the form of either an initial course or a refresher course. In addition, the waste manager shall have a minimum of two (2) years' experience on projects involving hazardous wastes (including Lead). It is acceptable for an individual who meets the criteria of the Competent Person, to also serve as the waste manager for this Contract as long as the individual fulfills all of the requirements of this paragraph.
4. **Lead Worker:** The Contractor shall have on staff and assigned to this Contract a sufficient number of lead workers who have successfully completed DOT Hazardous Materials Transportation Training and Lead Awareness Training courses as defined in this Section. Each training course shall have been completed within the past year in the form of either an initial course or a refresher course. In addition, each lead worker shall have a minimum of one (1) year of experience on projects involving Lead, and have worked on at least three (3) projects of comparable scope and methodologies to the work being conducted under this Section.
  - a. DEP EHS Policies and Procedures require EPA-certified Lead training for all Lead Abatement activities. Lead Awareness Training satisfies the training requirement for all other lead removal activities (e.g., spot removal and demolition work).
5. **Air Monitor:** The Contractor shall have an Air Monitor assigned to this Contract who has successfully completed Lead Awareness Training course as defined in this Section. This training course shall have been completed within the past year in the form of either an initial course or a refresher course. In addition, the Air Monitor shall have a minimum of two (2) years' experience in conducting Area Monitoring and Exposure Monitoring on projects involving hazardous wastes (including Lead). It is acceptable for an individual who meets the criteria of the Competent Person (as defined in this Section) or waste manager (as defined in this Section), to also serve as the Air Monitor for this Contract as long as the individual satisfies all of the requirements of this paragraph.

## GENERAL SPECIFICATION 13283 - LEAD MANAGEMENT

---

### 1.08 SUBMITTALS

- A. Thirty business days prior to the Work of this Section or as directed by the Engineer, the Contractor shall submit the following to the Engineer:
1. Lead Inspection and Sampling Plan: The Contractor shall provide a Lead Inspection and Sampling Plan to identify suspect lead-containing materials and collect confirmatory samples, as appropriate during the inspection. The Lead Inspection and Sampling Plan shall include at a minimum:
    - a. Credentials of the individual responsible for inspection and sampling. At a minimum, the inspection shall be performed by an Environmental Professional, as defined within this Section, who has current HAZWOPER, Lead Awareness, OSHA 10-hour, and confined space trainings, as applicable to the location of the work, and has performed inspection work on at least three (3) projects of comparable scope.
    - b. Credentials of the laboratory providing sample analysis. The credentials shall include current certification by the New York State Department of Health's (NYSDOH) Environmental Laboratory Approval Program (ELAP).
    - c. Sample collection, analysis and reporting protocol.
  2. Lead Inspection Report: The Contractor shall provide a Lead Inspection Report prepared by the Environmental Professional summarizing the results of all inspection activities, and as applicable, a sampling narrative, laboratory data packages and inventory of all identified suspect and confirmed lead-containing materials.
  3. Lead Management Plan(s): Each Contractor that will disturb Lead or other heavy metals during the course of Work to be performed under this Section shall submit a detailed, project-specific Lead Management Plan that addresses Work procedures and equipment to be used during the disturbance, removal, handling, collection, and disposal of Lead-Containing Materials and Lead Wastes. Work requiring a Lead Management Plan includes, but is not limited to, Abatement, spot removal, and construction/demolition activities. The Lead Management Plan shall be prepared in accordance with OSHA Construction Standards and all other pertinent federal, state, and local regulations. In addition, the Lead Management Plan shall follow all DEP EHS Policies and Procedures (referenced in this Section), and shall be coordinated with BEDC. The Lead Management Plan shall also be signed and dated by a CIH meeting the definition in this Section.
    - a. Lead Control:

## GENERAL SPECIFICATION 13283 - LEAD MANAGEMENT

---

- 1) Drawings showing the location and details of the following: (a) each Lead Control Area; (b) each Hygiene Facility; (c) proposed electrical hookups; (d) proposed water hookups; (e) each waste storage area; (f) restroom areas; (g) areas designated for eating, drinking, and smoking;
- 2) A detailed discussion regarding the interfacing of trades (i.e., how the Contractor will coordinate the Work with other contractors or DEP employees working at the Site) and the sequencing of Lead-related Work;
- 3) A detailed discussion regarding the collection, handling procedures, and disposal of Lead-Containing Materials and Lead Wastes (including the collection, filtering, and disposal of wastewater);
- 4) A detailed discussion regarding the procedures and methodologies that will be used to conduct Exposure Monitoring and Area Monitoring for particulates. Also, provide the name and qualifications (i.e., training and experience documentation) of the Air Monitor who will be responsible for conducting the air monitoring activities. The Air Monitor shall at a minimum, satisfy the qualification requirements set forth in this Section;
- 5) A detailed discussion regarding housekeeping procedures to be used for maintaining clean work areas and clean Hygiene Facilities;
- 6) A detailed discussion regarding the specific methods and procedures of emissions control that will be used to ensure that airborne contaminant levels do not meet or exceed an OSHA Action Level outside of each Lead Control Area. It should be noted that even after paint/coating removal, the DEP has found that demolition activities (e.g., torch-cutting abated steel) still have the potential to generate elevated airborne levels of Lead. Therefore, the Contractor shall provide engineering controls to capture potential Lead dusts or fumes emitted during demolition work that involves the cutting or burning of steel structures that have already been abated;
- 7) A detailed task analysis for each Work activity that has the potential to disturb Lead-Containing Materials or Lead Wastes. Each task analysis shall include, but is not

## GENERAL SPECIFICATION 13283 - LEAD MANAGEMENT

---

limited to, the following information: (a) the type of work activity; (b) the tools/equipment that will be used; (c) operation and maintenance practices and procedures that will be used for the tools/equipment; (d) the types of Lead-Containing Materials that may be disturbed or Lead Wastes that may be generated when performing the activity; (e) the engineering controls that will be used to control the spread of contamination during the activity; (f) the proposed crew size for the activity and individual employee responsibilities during the activity; (g) housekeeping procedures that will be used during the activity; (h) PPE and proposed respiratory protection that will be used for the activity;

- 8) Equipment and Supplies: Identify the equipment and supplies that will be used to perform the Work;
  - 9) Rental Equipment Notification: If rental equipment is to be used during the Work, the Contractor shall notify the rental agency in writing concerning the intended use of the equipment. Rental equipment data demonstrating compliance with the performance requirements of this Section must be presented to and approved by the Engineer prior to use;
  - 10) SDSs: Provide SDSs for all chemical products (including chemical stripping products) to be used for the Work, and refer to the NPG;
  - 11) The name and qualifications (i.e., experience and training documentation) of the Competent Person who will be responsible for the oversight and execution of the Lead Management Plan during all activities affecting Lead-Containing Materials and Lead Wastes. At a minimum, the Competent Person shall satisfy the qualification requirements set forth in this Section and be present whenever Work of this Section is being performed.
- b. Waste Management:
- 1) The identification of Lead-Containing Materials, Lead Wastes, and hazardous wastes (as defined in 40 CFR 116, 40 CFR 260, 40 CFR 261, 6 NYCRR 370 and 6 NYCRR 371) associated with the Work;

## GENERAL SPECIFICATION 13283 - LEAD MANAGEMENT

---

- 2) The estimated quantity of each waste stream (regulated and non-regulated) that will be generated and disposed of/recycled as per 40 CFR 302;
- 3) The name, address, phone number, and qualifications for each vendor and facility that will be transporting, storing, testing, or disposing of the wastes. The Contractor shall verify the permit status of the facility as well as check for outstanding violations and enforcement actions. Include a 24-hour phone contact for each vendor and facility;
- 4) Current permit documentation for each recycling facility or TSDF indicating that the facility is approved by federal, state, and local regulatory agencies to receive Lead-Containing Materials and Lead Wastes. The documentation shall include an “acceptance letter” from each TSDF indicating its ability to accept the specific waste streams that will be generated during Work performed under this Section;
- 5) Current 6 NYCRR 364 and 40 CFR 263 permit documentation for the waste transporter that will transport Lead-Containing Materials and Lead Wastes from the Work Site to the TSDF. The documentation shall clearly indicate the transporter’s ability to deliver the Lead-Containing Materials and Lead Wastes to the chosen TSDF;
- 6) Spill prevention, containment, and cleanup contingency measures to be implemented during the Work, as well as procedures to be followed during a suspected Lead emissions/bulk material release or emergency situation. All measures and procedures shall be in accordance with the standards referenced in this Section;
- 7) A detailed discussion of the on-site handling, storage, removal, and disposal of waste materials. This discussion shall include, but is not limited to, the following: (a) specifications for a secondary containment system for each drum storage area; (b) the methods of demarcation that will be used to identify the waste storage areas and each waste container; (c) the methods and procedures that will be used to collect and containerize wastes on a daily basis; (d) the types of containers that will be used to containerize the wastes;

## GENERAL SPECIFICATION 13283 - LEAD MANAGEMENT

---

- (e) the submittal of weekly regulated waste inspection and inventory records as required in this Section;
- 8) The name and qualifications (i.e., experience and training documentation) of the waste manager who will be responsible for the oversight and execution of the Lead Management Plan during waste management activities involving Lead-Containing Materials and Lead Wastes. At a minimum, the waste manager shall satisfy the qualification requirements set forth in this Section.
- c. A detailed schedule for the implementation of the Lead Management Plan elements. The schedule shall clearly indicate the starting and completion dates for the work, and shall allow adequate time for cleanup, inspections, and air monitoring activities.
- d. Medical Surveillance: For all activities that result in airborne Lead concentrations equal to, or in excess of the Action Level (as defined in 29 CFR 1926.62), or for those activities that take place within a Lead Control Area, the Contractor shall submit for this Contract a sufficient number of properly trained and experienced workers, each of whom shall: (a) have completed initial blood testing (including Zinc Protoporphyrin (ZPP) testing), and have a Blood Lead Level (BLL) below 35 micrograms per deciliter ( $\mu\text{g}/\text{dl}$ )(if the worker's BLL is in excess of 35  $\mu\text{g}/\text{dl}$ , the worker shall show medical approval for this Work); (b) have received a medical exam that included a Pulmonary Function Test (PFT) within the past year; (c) have received written medical clearance within the past year, by a licensed health care professional, to wear a respirator; (d) have received a qualitative or quantitative respirator fit-test for the specific respirator the employee will be using for this Work within the past year.
- e. Employee Documentation: For all activities that result in airborne contaminant concentrations (i.e., heavy metals or PCBs) equal to, or in excess of an Action Level, PEL, or REL, or for those activities that take place within a Lead Control Area, the Contractor shall provide a sufficient number of properly trained and experienced workers, each of whom shall: (a) have written proof of training (e.g., certificates) in accordance with the qualification requirements of this Section for lead workers, Competent Persons, waste managers, and Air Monitors that will be used for the Work; (b) copies of resumes for lead workers, Competent Persons, waste managers, and Air Monitors that will



## GENERAL SPECIFICATION 13283 - LEAD MANAGEMENT

---

be used for the Work, indicating work experience as required in this Section; (c) dates and written proof of initial medical surveillance by the Contractor or other employer within the past year, and proof that the employee is currently participating in the employer's ongoing medical surveillance program in accordance with this Section; (d) dates and written proof of respiratory clearance and a medical exam in accordance with this Section; (e) dates and written proof of a respirator fit-test in accordance with this Section.

- f. A current (i.e., within the last month) signed and notarized statement disclosing all of the Contractor's OSHA, EPA, and DOT citations/violations on projects involving Lead within the past three (3) years. If the Contractor will be using a subcontractor, a current signed and notarized statement disclosing all of the subcontractor's OSHA, EPA, and DOT citations/violations on projects involving Lead within the past three (3) years will also be required.
4. Analytical Laboratory Qualifications for Analyzing Suspect Lead-Containing Materials and Wastes: Submit the name, address, and telephone number of each analytical laboratory selected to perform the analyses of waste samples (solid and liquid), air samples collected for Area Monitoring and Exposure Monitoring purposes, and paint/coating samples collected to classify building components. The analytical laboratory shall be currently accredited by the American Industrial Hygiene Association (AIHA) and the NYSDOH ELAP. Provide copies of current AIHA and ELAP certificates along with dates of accreditation/reaccreditation. ELAP certificates must show evidence of certification for the specific analytical methods that will be used to analyze each type of sample that will be collected.
- B. Field Reports and Recordkeeping: During all Work performed under this Section, the Contractor shall maintain and provide the following documentation:
1. Air Monitoring Documentation: All air monitoring results and daily air monitoring reports shall be provided to the DEP within 24-hours from the date the samples are collected. The results shall be signed by the laboratory employee who analyzed or supervised the analysis of the samples, as well as the Air Monitor that physically performed the air monitoring activities at the Work Site. All laboratory analytical results shall be accompanied by complete COC documentation.
    - a. Each daily air monitoring report shall be signed by the Contractor's employee who generated the report. The content of these reports shall include, but is not limited to, the following

## GENERAL SPECIFICATION 13283 - LEAD MANAGEMENT

---

information: (a) sample “start” and “stop” times; (b) flow rates (initial and final) for each sample; (c) the total volume of air collected for each sample; (d) sample location descriptions/sample location drawings/names of individuals being sampled; (e) types (i.e., makes and models) of sampling equipment used; (f) types of sample media (i.e., filters and cassettes) used; (g) the most recent calibration dates, along with the calibration results, for the sampling equipment used; (h) the name of the Air Monitor that conducted the air monitoring; (i) dates that the air monitoring was conducted; (j) work tasks being performed during the air monitoring; (k) unique sample numbers used to identify each sample.

2. Waste Documentation: Completed and signed waste manifests from TSDFs shall be provided to the DEP as soon as possible but no later than 30 days after disposal. In addition, on-site waste storage areas shall be inspected weekly by the waste manager, who at a minimum shall satisfy the qualification requirements of this Section.
  - a. Each waste storage area inspection shall be coordinated with the Engineer, documented in the form of a written report, and each report shall be signed by the Contractor’s employee who generated the report. All reports shall be provided to the DEP within 24-hours of the date the inspection is completed. The content of these reports shall include, but is not limited to, the following information: (a) the name of the individual that conducted the inspection; (b) descriptions of waste streams being stored; (c) types and quantities of waste containers being used; (d) the current disposal status (i.e., when each waste container is scheduled to be removed from the Work Site) and physical condition of each waste container; (e) the presence/absence of proper labeling for each waste container in accordance with this Section and federal, state, and local regulations; (f) secondary containment systems being used; (g) the methods being used to secure/lock each waste storage area to prevent any unauthorized entry; (h) the presence of any waste containers on site generated during the Work performed under this Section that violate RCRA generator storage time limitations, as defined in 40 CFR 262.
  - b. In addition to performing weekly waste storage area inspections, the waste manager shall also maintain an ongoing waste inventory. The waste inventory shall be coordinated with the Engineer, and the content of the inventory record shall include, but is not limited to, the following information: (a) specific dates that each waste container was added/removed from the waste

## GENERAL SPECIFICATION 13283 - LEAD MANAGEMENT

---

storage area; (b) the full name (printed) and signature of the individual responsible for adding/removing each waste container from the waste storage area.

3. Lead Control Area Inspection Documentation: Lead Control Areas shall be inspected daily by the Competent Person.
  - a. Each daily Lead Control Area inspection shall be documented in the form of a written report, and each report shall be signed by the Contractor's employee who generated the report. All reports shall be provided to the DEP no later than 24-hours after the inspection is completed. The content of these reports shall include, but is not limited to, the following information: (a) the types of Work being performed; (b) the names of the lead workers, Competent Person, waste manager, and Air Monitor on site, as well as the name of the company each individual is representing; (c) the types of air monitoring (i.e., Exposure Monitoring or Area Monitoring) being conducted, and the number of samples being collected for each type of air monitoring activity; (d) any non-compliance issues observed (i.e., observations that conflict with the requirements of the Contractor's Lead Management Plan, this Section, DEP EHS Policies and Procedures, or federal, state, and local regulations) along with the corrective actions that were taken to achieve compliance.
4. Contractor Project Record: The Contractor's Competent Person shall maintain a project record at the Work Site. The Contractor project record shall be made available to the Engineer or DEP for review at any time during the Work, and shall be submitted to the DEP within 24-hours after the completion of the Work.
  - a. At a minimum, the Contractor project record shall contain the following information: (a) copies of training certificates for all individuals involved with the Work; (b) copies of all air monitoring results generated during the Work; (c) copies of all available paint chip/coating sample analytical data and XRF analyzer data, as well as paint/coating survey reports related to the Work; (d) copies of all daily sign-in sheets as required in this Article; (e) a list of emergency phone numbers, including the local fire department, local police department, nearest hospital, as well as phone numbers for the Engineer and DEP personnel responsible for administering the Work; (f) a copy of the OSHA Lead in Construction Standard (29 CFR 1926.62); (g) copies of all SDSs pertaining to all chemicals being used during the Work; (h) a copy of this Section and the related Drawings; (i) a copy of

## GENERAL SPECIFICATION 13283 - LEAD MANAGEMENT

---

- the Contractor's Lead Management Plan; (j) copies of all daily Lead Control Area inspection records; (k) copies of all weekly waste storage area inspection records; (l) a copy of the waste inventory; (m) copies of all DEP EHS Policies and Procedures referenced in this Section (n) a copy of the Contractor's Hazard Communication (HAZCOM) program.
- b. If it is determined that arsenic, cadmium, or chromium is present in addition to Lead, the Contractor project record shall also include copies of each applicable OSHA Standard (i.e., Inorganic Arsenic in Construction Standard (29 CFR 1926.1118), Hexavalent Chromium in Construction Standard (29 CFR 1926.1126), or Cadmium in Construction Standard (29 CFR 1926.1127).
5. Daily Sign-In Sheets: The Contractor shall generate daily sign-in sheets for all individuals entering and exiting each Lead Control Area for the duration of the Work. The daily sign-in sheets shall be maintained by the Competent Person, and shall be made available to the Engineer or DEP for review at any time during the Work. All daily sign-in sheets shall be submitted to the DEP within 24-hours after the completion of the Work.
- a. At a minimum, each daily sign-in sheet shall include: (a) the individual's full name (printed); (b) the individual's signature; (c) the name of the company the individual is representing; (d) the time of entry and exit from each Lead Control Area; and (e) verification by the Competent Person that the individual meets the applicable training requirements, if the individual intends to enter a Lead Control Area.
6. HAZCOM Program: The Contractor's HAZCOM program shall be made available to the Engineer or DEP for review at any time during the Work.

### PART 2 PRODUCTS

#### 2.01 MATERIALS

- A. Respirators: The Contractor shall select respirators approved by the NIOSH for use in areas where paints/coatings, dusts, materials, or wastes containing contaminants may be disturbed. At a minimum, the Contractor shall provide each individual with a half-face, negative pressure, air purifying respirator equipped with HEPA/P-100 Filter cartridges (and Organic Vapor Cartridges if PCBs are present), until Exposure Monitoring results indicate that respiratory protection can be modified. The Contractor's CIH shall make all determinations regarding respiratory protection modifications that will be implemented for the

## GENERAL SPECIFICATION 13283 - LEAD MANAGEMENT

---

Work. All modifications shall be in accordance with the OSHA Lead in Construction Standard (29 CFR 1926.62), Inorganic Arsenic in Construction Standard (29 CFR 1926.1118), Hexavalent Chromium in Construction Standard (29 CFR 1926.1126), Cadmium in Construction Standard (29 CFR 1926.1127), and the Contractor's Lead Management Plan.

- B. PPE: The Contractor shall provide personnel who have a potential to be exposed to materials or wastes containing contaminants, with appropriate PPE as prescribed by the Contractor's CIH.
- C. HEPA Filters: HEPA/P-100 Filters used in vacuuming equipment, power tools, and local exhaust equipment must meet or exceed any manufacturer's specifications and recommendations, as well as specifications presented in the Standard for Safety High Efficiency, Particulate, Air Filter Units (UL 586).
- D. Waste Containers: Containers for the storage of all wastes shall be DOT-approved, and shall be provided by the Contractor.
- E. Abrasives: Mechanical paint/coating removal equipment shall not use any products containing crystalline silica, and the equipment shall not utilize any non-recoverable materials or any cutting materials which introduce toxic or hazardous materials into the environment.
- F. Chemical Strippers: The Contractor shall utilize an environmentally safe chemical paint stripping system, with demonstrated suitability and efficiency in preparing cast-in-place concrete, cement, and plaster surfaces that are free of any visible residues of paints/coatings. The system shall include non-alkaline or alkaline strippers that provide the lowest possible level of toxicity consistent with the types of paints/coatings to be removed. Neutralization products and procedures shall be provided for all alkaline stripping systems, no stripping system shall contain methylene chloride, and the stripping system shall be low in volatile organic compounds (VOCs).

### PART 3 EXECUTION

#### 3.01 PREPARATION

- A. Hygiene Facilities: The Contractor shall provide functional Hygiene Facilities as defined in this Section that are appropriate for the types of Work to be performed under this Section. The Contractor shall ensure that employees do not leave a Lead Control Area wearing any potentially contaminated PPE. Using compressed air to dislodge dust from clothing/PPE shall be strictly prohibited. The Contractor shall collect, test, and properly dispose of all wastewater generated from Hygiene Facilities.
  - 1. Handwash Stations: The Contractor shall provide functioning handwash stations on all projects that disturb Lead-Containing Materials or Lead Wastes. Handwash stations shall have running water at the tap, clean

## **GENERAL SPECIFICATION 13283 - LEAD MANAGEMENT**

---

towels, and soap per 29 CFR 1926.51. Substituting “hand wipes” in place of soap and running water will not be acceptable.

2. Showers: The Contractor shall provide shower facilities in accordance with 29 CFR 1926.62, for use by employees whose airborne exposure to Lead is above the PEL. When shower facilities are necessary, employees are required to shower at the end of the work shift each day prior to leaving the Lead Control Area that they are working in.
- B. Utilities: The temporary use of any on-site utilities shall be subject to the approval of the DEP. The Contractor shall furnish all water and hoses needed for the Work, as well as any temporary hookups. Also, the Contractor shall supply all heating equipment and water filtration devices needed for the Work. In addition, all temporary lighting and temporary electrical service to a Lead Control Area shall be provided by the Contractor, and shall be in weather-proof enclosures and be ground fault protected.
- C. Signs: The Contractor shall post conspicuous warning signs at all approaches to work areas and waste storage areas. The signs shall be located at such a distance so that personnel may read the sign and take the necessary precautions before entering a work area or waste storage area. Signs shall comply with federal, state, and local regulations, including the requirements of OSHA. Signs shall not be removed until all Abatement, removal, and construction/demolition activities have been completed. At a minimum, each sign shall bear the following information in English and the predominant language that is spoken by the Contractor’s employees if English is not spoken:

**DANGER**  
**LEAD WORK AREA**  
**MAY DAMAGE FERTILITY OR THE UNBORN CHILD**  
**CAUSES DAMAGE TO THE CENTRAL NERVOUS SYSTEM**  
**DO NOT EAT, DRINK OR SMOKE IN THIS AREA**

1. Each sign shall be appropriately modified to include additional warnings for other contaminants that are identified during Exposure Monitoring.
- D. Physical Boundary Delineation: The Contractor shall clearly delineate each Work area and waste storage area with a Physical Boundary as defined in this Section.
- E. Work Area Preparation: The Contractor shall utilize HEPA-filtered vacuums, and wet methods during the initial cleaning of each work area. Prior to removal from each work area, all movable objects and mounted objects that can be

## GENERAL SPECIFICATION 13283 - LEAD MANAGEMENT

---

removed shall be pre-cleaned using HEPA-vacuums and wet methods. Fixed objects that must remain within each work area shall be pre-cleaned using HEPA vacuums and wet methods, and subsequently covered with 6-mil polyethylene sheeting.

### 3.02 AIR MONITORING

- A. Air monitoring for airborne concentrations of Lead and other heavy metals shall be conducted by the Air Monitor in accordance with OSHA and as defined in this Section.
  - 1. Exposure Monitoring: For Work involving the disturbance of any detectable concentration of Lead or other heavy metals the Contractor shall collect personal air samples from employees who are anticipated to have the greatest risk of exposure, as determined by the Contractor's CIH or Competent Person. Personal air samples shall be collected during every work shift from at least one (1) employee that is representative of each type of work task that is being performed. Each personal air sample shall "run" for the employee's entire work shift in order to ensure that enough volume (of air) is collected and an accurate 8-hour TWA can be calculated. Documentation regarding the sample numbers, specific shift when the sampling was conducted, the work tasks that were sampled, the dates of sampling, the employee hours that were worked during the shift, and the total sampling times, shall accompany each laboratory COC form.
    - a. Exposure Monitoring for other heavy metals may be discontinued following a complete negative exposure assessment and approval from the Engineer and the Contractor's CIH. However, daily Exposure Monitoring for Lead shall remain, regardless of the negative exposure assessment results.
- B. Area Monitoring: The Contractor shall collect a minimum of two (2) area air samples outside of each Lead Control Area on a daily basis for the duration of the Abatement, removal, or construction/demolition Work, as well as any other Work involving the disturbance of Lead-Containing Materials or Lead Wastes. During sampling activities, all air sample filter cassettes shall be positioned approximately five to six feet above the ground (in order to simulate an individual's breathing zone), and shall not be placed immediately adjacent to obstructions (e.g., walls or columns) which may restrict the flow of air to the filter cassettes. Each air sample shall be analyzed for all contaminants identified during the exposure assessment. If area air monitoring indicates an emission level in excess of an OSHA Action Level outside of a Lead Control Area, all Work in that area shall be stopped immediately. The Contractor shall then take immediate corrective actions to reduce emission levels to below the Action Level(s), and the Contractor shall clean all adjacent areas that may have become contaminated due to the emissions. Documentation regarding the sample

## **GENERAL SPECIFICATION 13283 - LEAD MANAGEMENT**

---

numbers, sample locations, the dates of sampling, the employee hours that were worked during the shift, and the total sampling times, shall accompany each laboratory COC form.

- C. Documentation: Complete documentation of all air monitoring activities shall be in accordance with this Section.
- D. The Contractor shall submit all air monitoring results to the DEP as soon as possible, but no later than five (5) days from when the air samples were collected.

### **3.03 BULK REMOVAL**

- A. Protection of Existing Work to Remain: All Work involving the disturbance of Lead-Containing Materials or Lead Wastes must be conducted without damage to, or contamination of equipment or surfaces within the work areas or other areas adjacent to the work areas. All such damage or contamination shall be immediately corrected and cleaned up by the Contractor at the Contractor's expense.
- B. Prohibited Activities: Contractors shall not conduct activities that are prohibited by OSHA and EPA regulations. The following activities are prohibited, regardless of whether they are conducted subject to an exposure assessment and written compliance program: (a) burning-off paints/coatings; (b) using heat guns operating above 1100oF; (c) dry machine sanding, grinding, or blasting paint without a HEPA vacuum exhaust tool; (d) uncontained hydroblasting or high-pressure washing; (e) welding painted/coated surfaces unless the paint/coating is removed at least 4-inches from area of heat application (per 29 CFR 1926.345(c)(1)), and local exhaust ventilation is used.
- C. Test Patches: Prior to choosing the paint removal method(s) for paints/coatings, the Contractor shall perform test patches on surfaces subject to Abatement, to determine if the method(s) meet the requirements of this Section.
- D. Mechanical Removal Equipment: When removing paints/coatings from metal surfaces, the paints/coatings must be removed to the extent that only the bare metal remains (i.e., no mill scale remains) as per SSPC SP 2, 3, 11, 15 and COM, as applicable. In the case of substrates other than metal (e.g., concrete, brick, and block), paints/coatings shall be removed from the surface of the substrate as per SSPC SP 13 and SSPC SP COM, as applicable, and managed in accordance with SSPC Guide 7. Acceptance of the Work shall be contingent upon inspection of the substrate surfaces by the Engineer and must demonstrate the absence of residual paint/coating layers that can be physically measured, pried loose, or peeled away using a scraping device. The Contractor may only use products and tools meeting the performance specifications outlined below:
  - 1. Contractor shall utilize a vacuum-assisted power tool system with demonstrated suitability and efficiency in preparing metal surfaces as



## GENERAL SPECIFICATION 13283 - LEAD MANAGEMENT

---

per SSPC Guide 6 and SSPC SP 11, and with demonstrated effectiveness in maintaining Lead emissions below OSHA exposure limits during the disturbance of paints/coatings. Such systems may include dustless needle guns, dustless rotopeens, and dustless right-angle grinders, all of which capture dust and debris at the cutting tool edge, and transport the material under vacuum conditions to an air-tight disposal container. Dustless needle guns shall only be utilized on metal surfaces.

2. The vacuum-assisted power tool system shall also be designed to permit the removal and replacement of collection containers under negative pressure in order to prevent the release of dusts. The system shall be equipped with an automatic “shut-off” in the event of vacuum failure.
3. Abrasive/recovery tools shall be monitored at all times by a device capable of determining recovery at the face of each tool, and capable of automatically disabling the tool in the event that recovery levels are insufficient. The monitor, at a minimum, shall have the following features: (a) a remote warning light; (b) an adjustable recovery set point; (c) automatic equipment disabling capabilities; (d) a sensing range of 0 - 5 pounds per square inch (psi); (e) solid state photohelic instrumentation; (f) remote sensing at the face of the tool.
4. The safe recovery point shall be calibrated each day before start-up, or each time a new tool or vacuum source is used. All manufacturer recommendations shall be followed with respect to the set up and use of the monitor, and the manufacturer's operations manual shall be kept on site at all times. A daily log shall be maintained by the Contractor, identifying all calibrations of recovery levels, as well as any “down time” as a result of insufficient recovery levels.
5. The cutting head of the vacuum-assisted power tool system that is used on flat surfaces shall be capable of cutting to within 1-1/2" of any inside corner, molding, or edge, and may include dustless rotopeens or dustless needle guns. Tools for corners and moldings shall be specifically designed for that purpose, and conform to all inside corners, outside corners, curved, flat, and angled surfaces that are to be abated under this Section. These tools shall also maintain vacuum control at the work surface/cutting head interface at all times. HEPA vacuum-shrouded needle guns may be used for non-flat surfaces in accordance with manufacturer recommendations. Vacuum-assisted finishing tools, such as right angle grinders, may be used to achieve the SSPC SP 11 standard, but may not be used for primary removal.
6. Vacuum-assisted power tool systems meeting all of the specifications outlined herein, may be used pending the submittal of all required performance documentation, and their acceptance by the Engineer. Any

## **GENERAL SPECIFICATION 13283 - LEAD MANAGEMENT**

---

tools which do not meet all of the specifications outlined herein, shall be removed from the project Site immediately, and shall not be used for the Work to be performed under this Section.

- E. Chemical Strippers: Acceptance of the Work shall be contingent upon inspection of the abated substrate surfaces by the Engineer, and must demonstrate the absence of residual paint/coating layers that can be physically measured, pried loose, or peeled away using a scraping device. The Contractor may only use products and paint stripping systems meeting the performance specifications outlined below:
1. The Contractor shall utilize a chemical paint stripping system with a demonstrated effectiveness in maintaining Lead emissions below OSHA exposure limits during the disturbance of paints/coatings. The Contractor shall utilize a mechanical ventilation system during the Work that exhausts away from occupied areas. The application of all paint stripping systems shall be in accordance with manufacturer recommendations and SSPC SP 1. Debris shall be managed in accordance with SSPC Guide 7.
  2. The Contractor should note that more than one product may be required to strip LCP/coatings. The use of multiple products shall be in accordance with Work practices approved by the individual manufacturer of each chemical paint stripping compound.
  3. All chemical paint stripping products shall be presented to the Engineer for approval prior to the start of any Work to be performed under this Section. When presenting the products to the Engineer, they shall be in the manufacturer's unopened, original containers bearing accurate information regarding the products. Also, the manufacturer's labels on each container shall be intact and legible.
  4. Chemical paint stripping systems meeting all of the requirements outlined herein, may be used pending the submittal of all required performance documentation, and its acceptance by the Engineer. Any products which do not meet all of the specifications outlined herein, shall be removed from the project site immediately, and shall not be used for the Work to be performed under this Section.

### **3.04 CLEANUP AND DISPOSAL**

- A. Cleanup: The Contractor shall maintain all surfaces, including protective coverings (polyethylene sheeting) within each work area, free of accumulations of paint chips/coating debris, dusts, and wastes. The Contractor shall perform housekeeping activities daily throughout each work shift and at the end of each work shift, in order to prevent any accumulation of paint chips/coating debris, dusts, and wastes in the work areas. Dry sweeping and using compressed air to cleanup a Work area shall be strictly prohibited. HEPA-filtered vacuums and

## GENERAL SPECIFICATION 13283 - LEAD MANAGEMENT

---

wet methods shall be used to ensure that each Work area remains free of visible paint chips/coating debris, dusts, and wastes.

- B. **Sampling and Laboratory Analysis of Paint Removal Wastes:** For hazardous waste characterization, the waste manager shall sample all potential heavy metal and PCB-containing waste streams in accordance with 40 CFR 261 and 6 NYCRR Part 371. All waste samples shall be collected in the presence of the Engineer using the following procedure:
1. One (1) composite waste sample shall be collected for laboratory analysis from each waste drum that is generated. Each composite sample shall be a mixture of four (4) grab samples. Each composite sample shall be labeled and submitted to a laboratory that satisfies the requirements of this Section. Each composite sample shall undergo Toxicity Characteristic Leaching Procedure (TCLP) analysis for the eight (8) RCRA metals.
  2. The Contractor shall also direct the laboratory to analyze each sample for any additional parameters that are required by the specific TSDF being used. In addition, if the waste stream is associated with the use of a chemical paint stripping system, the Contractor shall have the laboratory analyze each sample for pH and any other RCRA characteristic that may fail due to the chemical composition of the waste. Furthermore, if the waste stream may contain PCB-containing paint/coating chips, the Contractor shall collect samples in accordance with Section 13284 - PCB Management. The Contractor shall ensure that the laboratory being used to satisfy the requirements of this Section is also capable of performing these additional analytical tests.
  3. One (1) representative wastewater sample shall be collected for laboratory analysis from each drum that generated. Each sample shall be collected using appropriate field sampling equipment (e.g., a pipette or bailer), and shall be labeled and submitted to a laboratory that satisfies the requirements of this Section.
- C. **Sampling and Laboratory Analysis of Painted Demolition Debris:** The Contractor shall collect representative bulk samples of demolition wastes to determine proper disposal. All bulk samples shall undergo TCLP analysis for the eight (8) RCRA metals. Furthermore, if the waste stream may contain PCB-containing paint/coating chips, the Contractor shall collect samples in accordance with Section 13284 - PCBs Management.
1. **Scrap Metal Exemption for Recycling:** Under 6 NYCRR 371.1(c)(7), painted scrap metal can be sent to a recycling facility, rather than be discarded as hazardous waste. In order for the DEP to submit a “c7 notification” to the NYSDEC and claim the “scrap metal exemption,” the Contractor must first submit notification to their recycling facility

## GENERAL SPECIFICATION 13283 - LEAD MANAGEMENT

---

indicating that Lead is present on the scrap metal. If PCBs at concentrations less than 50 ppm or other heavy metals are detected in the paints/coatings on the scrap metal, the Contractor shall also disclose this information to the recycling facility. The Contractor shall receive written permission from the recycling facility indicating that the facility will accept the Lead, heavy metal, and PCB paint/coated scrap metal (if PCB concentrations are less than 50 ppm) generated during the Work to be performed under this Section. Scrap metal with PCBs in paints/coatings at concentrations of 50 ppm or greater may not be recycled, see 13284 – PCB Management. The Contractor shall submit this documentation to the Engineer for approval prior to disposal.

- D. **Collection, Separation, and Containerization of Wastes:** The Contractor shall collect, separate (by waste stream/waste type), and containerize Lead Wastes (solid and liquid), debris, PPE, and containment materials on a daily basis in accordance with the Lead Management Plan. Where the TCLP analysis for the eight (8) RCRA metals are below hazardous waste standards, all PPE, poly and paint/coating waste will be characterized as lead-containing non-hazardous, contaminated waste, and should not be managed as construction and demolition (C&D) debris.
1. The Contractor shall store all wastes in DOT-approved container systems. No drum/container shall be filled in excess of the capacity marked on the drum/container. All drums/containers shall be sealed and covered immediately after filling, and each drum/container shall have a label affixed to it in accordance with the requirements of this Section. All labels shall remain intact and legible at all times.
  2. No water mixed with or contaminated by hazardous waste may be released onto the ground or into any drain or sewer (RCNY Title 15, Chapter 19). It should be noted that a discharge of more than 10 lb of Lead (this includes 10 lb of debris containing Lead) onto the ground or into the water within a 24-hour period, shall be considered a violation of the Clean Water Act and shall be treated as a “reportable quantity” in accordance with 40 CFR 117. Such a release shall be grounds for immediate termination of this Contract, and the Contractor shall be liable for any fines, penalties, or remediation costs.
  3. The Contractor shall store non-hazardous wastes separately from hazardous wastes, shall provide all non-hazardous waste containers, and shall make all transportation and disposal arrangements for non-hazardous wastes in accordance with federal, state, and local regulations.
- E. **Storage of Wastes:** The Contractor shall ensure that all drummed wastes are stored in a secondary containment system, and that each waste storage area is demarcated with a Physical Boundary. In addition, the Contractor shall post

## GENERAL SPECIFICATION 13283 - LEAD MANAGEMENT

weekly waste inspections and waste inventories in the regulated waste storage area, as required in this Section, as well as the following emergency information in accordance with DEP's EHS Policies and Procedures: (a) the name and telephone number of the facility's Emergency Coordinator; (b) the location of fire extinguishers and fire alarms; (c) the location of spill control materials; (d) the telephone number for the fire department (unless the facility has a direct alarm).

- F. Labeling: The Contractor shall affix warning labels to all hazardous waste drums/containers. Labels shall comply with the requirements of federal, state, and local regulations. At a minimum, all hazardous waste labels shall bear the following information in English:

**HAZARDOUS WASTE**  
**FEDERAL LAW PROHIBITS IMPROPER**  
**DISPOSAL**  
**HANDLE WITH CARE**  
**[Generator Name, Address, and Telephone Number]**  
**[Specific Contents of Container]**  
**[EPA-Issued Generator Identification Number]**  
**[EPA Waste Identification Number]**  
**[Accumulation Start Date]**  
**[Accumulation End Date]**

1. If waste classification is pending analysis, labels shall indicate "Hazardous Waste - Pending Analysis." If wastes contain PCBs, drums/containers must also be labeled per Section 13284 - PCB Management.
- G. Disposal of Wastes: All hazardous waste profiles for containerized wastes must be reviewed by the Engineer and signed by the DEP as the generator of the waste streams. The Contractor shall notify the DEP at least 14 business days prior to the removal of any waste drums/containers, so that the DEP can inspect the drums/containers and the waste manifests. Wastes shall be disposed of to ensure that drums/containers do not remain on the job site for more than 90 calendar days from the initial "accumulation start date" on the label affixed to the drum/container. Containers that have reached their storage capacity shall not remain on site, and transportation arrangements shall be made for their immediate removal.
- H. Disposal Documentation: The Contractor shall submit written evidence that the TSDF receiving lead-containing wastes is approved by federal (40 CFR 264 and 40 CFR 265), state (6 NYCRR 373), and local regulatory agencies to receive the wastes. If regulated PCBs (as defined in Section 13284 - PCB Management) were detected in the wastes, the Contractor shall also ensure that the TSDF is approved by federal, state, and local regulatory agencies to receive these wastes. Once all waste profiles have been completed, the Contractor shall

## **GENERAL SPECIFICATION 13283 - LEAD MANAGEMENT**

---

provide the DEP a “Letter of Acceptance” issued from the TSDf indicating that the wastes will be accepted. On the date of disposal, the Contractor shall submit one (1) copy of the completed manifest that has been signed and dated by the initial transporter in accordance with 6 NYCRR 372 and 40 CFR 262, to the DEP for signature as Generator. All waste profiles, manifests, and Land Disposal Restrictions (LDRs) must be signed by a DEP employee per 6 NYCRR 376 and 40 CFR 268, and as described in Section 01355- Hazardous Materials Control.

END OF SECTION

**SECTION 13284  
PCB Management**

**PART 1        GENERAL**

**1.01        SUMMARY**

- A. This Section details the requirements for construction and demolition activities affecting materials and structures coated with or containing polychlorinated biphenyls (PCBs), as shown on the Contract Drawings, specified herein, or required to complete the Work, including all affected coatings identified and impacted by the Work. All Work to be performed under this Section shall be performed using methods, tools, and equipment that have demonstrated effectiveness in preventing airborne emissions from migrating outside of Work areas.
- B. For construction and demolition activities affecting materials and structures that are also coated with heavy-metal-containing (i.e., arsenic, cadmium, chromium, or lead) paints or coatings, refer to Section 13283 - Lead Management and SSPC Guide 7. For construction and demolition activities affecting materials and structures that are also coated with asbestos-containing materials (ACM), refer to Section 13281 - Asbestos Management. For construction and demolition activities affecting materials and structures that are also impacted by mercury, refer to Section 13283 – Mercury Management.
- C. Small Capacitors and Fluorescent Light Ballasts manufactured prior to 1978 may contain PCBs in their capacitors or potting materials. Unless a Fluorescent Light Ballast is marked “No PCBs” by the manufacturer, it shall be assumed that the ballast contains PCBs. All PCB-containing light ballasts and Small Capacitors shall be removed, handled, packaged, and disposed of in accordance with this Section.
- D. All Work under this Section shall be performed to minimize the creation of airborne emissions; minimize the quantity of hazardous waste generated; protect the health and safety of all site personnel and the welfare of the public; and avoid adverse environmental impacts.
- E. Unless otherwise specified, the Work of this Section shall also be performed in accordance with the most current New York City Department of Environmental Protection (DEP) Environmental Health and Safety (EHS) Policies and Procedures (including PCB Management, Hazardous Waste Management, and Spill Prevention, Environmental Release Reporting and Investigation), and applicable federal, state, and local regulations.
- F. In the absence of analytical testing results for a specific painted/bitumastic-coated material, the material shall be classified as PCB-containing and lead-containing. If the material is caulking or has a bitumastic coating, the material shall also be classified as asbestos containing. Any unforeseen PCB, asbestos,

**GENERAL SPECIFICATION 13284 - PCB MANAGEMENT**

---

or lead-containing paints/bitumastic coatings discovered during the Work to be performed under this Section shall be remediated as necessary to complete the Work in accordance with this Section.

- G. The Contractor shall perform all Work under this Section without damaging or contaminating areas adjacent to where the Work is being performed. Where such areas are damaged or contaminated, as determined by the DEP, the Contractor shall restore the areas to their original condition at no additional cost to the DEP.
- H. The following index of this Section is presented for convenience:

<u>Article</u>	<u>Title</u>	<u>Page</u>
		13284-
PART 1	GENERAL .....	1
1.01	Summary .....	1
1.02	Payment.....	2
1.03	Related Sections.....	3
1.04	Reference Standards.....	3
1.05	Definitions.....	5
1.06	Description.....	10
1.07	Quality Assurance.....	11
1.08	Submittals .....	14
PART 2	PRODUCTS.....	25
2.01	Materials .....	25
PART 3	EXECUTION.....	26
3.01	Preparation .....	26
3.02	Air Monitoring .....	27
3.03	Bulk Removal .....	28
3.04	Cleanup and Disposal .....	31

1.02 PAYMENT

- A. Except for unforeseen PCB-containing materials and related work eligible for payment under allowance, as described in Section 01355 – Hazardous Materials Controls, no separate payment will be made for performing any work of this Section and the Contractor shall include all costs thereof in its lump sum price bid for the Contract, except as specified herein.
- B. Payment for removal and disposal of unforeseen PCB-containing materials not described and/or not shown on the Contract Documents will be made as specified in Section 01270 – Measurement and Payment.
- C. Payment for the disposal of PCB Wastes will not be made until a signed copy of the manifest from the Treatment, Storage, and Disposal Facility (TSDF),



certifying the amount of PCB Wastes delivered is returned with complete chain-of-custody (COC) documentation to the DEP.

1.03 RELATED SECTIONS

- A. Section 01270 -- Measurement and Payment
- B. Section 01355 -- Hazardous Materials Control
- C. Section 01356 -- Environmental Health and Safety Requirements
- D. Section 01733 -- Construction Waste Management
- E. Section 02222 -- Demolition and Removals
- F. Section 13281 - Asbestos Management
- G. Section 13282 -- Mercury Management
- H. Section 13283 -- Lead Management

1.04 REFERENCE STANDARDS

- A. The Contractor shall comply with all applicable regulations, standards, and guidelines of federal, state, and local environmental and occupational safety and health agencies regarding PCB-Containing Materials and PCB Wastes. These regulations, standards, and guidelines include, but are not limited to the following:
  - 1. United States (U.S.) Department of Transportation (DOT):
    - a. 49 CFR 171 - General Information, Regulations, and Definitions
    - b. 49 CFR 172 – Hazardous Materials Table, Special Provisions, Hazardous Materials Communications, Emergency Response Information, and Training Requirements
    - c. 49 CFR 173 – Shippers: General Requirements for Shipments and Packaging’s
    - d. 49 CFR 178 – Specifications for Packaging’s
  - 2. United States Environmental Protection Agency (EPA):
    - a. 40 CFR 116 – Designation of Hazardous Substances
    - b. 40 CFR 117 – Determination of Reportable Quantities for Hazardous Substances
    - c. 40 CFR 260 – Hazardous Waste Management Systems: General
    - d. 40 CFR 261 – Identification and Listing of Hazardous Waste
    - e. 40 CFR 262 – Standards Applicable to Generators of Hazardous Waste

## GENERAL SPECIFICATION 13284 - PCB MANAGEMENT

---

- f. 40 CFR 263 – Standards Applicable to Transporters of Hazardous Waste
  - g. 40 CFR 264 – Standards for Owners and Operators of Hazardous Waste Treatment, Storage, and Disposal Facilities
  - h. 40 CFR 265 – Interim Status Standards for Owners and Operators of Hazardous Waste Treatment, Storage, and Disposal Facilities
  - i. 40 CFR 268 – Land Disposal Restrictions
  - j. 40 CFR 302 – Designation, Reportable Quantities, and Notification
  - k. 40 CFR 761 – Polychlorinated Biphenyls (PCBs) Manufacturing, Processing, Distribution in Commerce, and Use Prohibitions
  - l. Method 8082A (SW-846) – Polychlorinated Biphenyls (PCBs) by Gas Chromatography
3. National Institute for Occupational Safety and Health (NIOSH):
- a. Method 5503 – Polychlorobiphenyls
4. New York City Department of Environmental Protection (DEP):
- a. Environmental Health and Safety Policies and Procedures – Vol. II, Spill Prevention, Environmental Release Reporting and Investigation
  - b. Environmental Health and Safety Policies and Procedures – Vol. IV, Hazardous Waste Management
  - c. Environmental Health and Safety Policies and Procedures – Vol. IV, PCB Management
  - d. RCNY Title 15, Chapter 19 – Discharges of Wastewater and Other Materials to Public Sewers
5. New York City Department of Buildings (DOB) – Building Code (Chapter 33)
6. New York State Department of Environmental Conservation (NYSDEC):
- a. 6 NYCRR 364 – Waste Transporter Permits
  - b. 6 NYCRR 370 – Hazardous Waste Management Regulations
  - c. 6 NYCRR 371 – Identification and Listing of Hazardous Waste
  - d. 6 NYCRR 372 – Hazardous Waste Manifest System and Related Standards for Generators, Transporters, and Facilities

- e. 6 NYCRR 373 – Hazardous Waste Management Facilities
- f. 6 NYCRR 376 – Land Disposal Restrictions
- g. 12 NYCRR 56 - Asbestos
- 7. Occupational Safety and Health Administration (OSHA):
  - a. 29 CFR 1910 – Occupational Safety and Health Standards
  - b. 29 CFR 1910.28 – Safety Requirements for Scaffolding
  - c. 29 CFR 1910.120 – Hazardous Waste Operations and Emergency Response
  - d. 29 CFR 1910.134 – Respiratory Protection Standard
  - e. 29 CFR 1910.1200 - Hazard Communication Standard
  - f. 29 CFR 1926 – Safety and Health Regulations for Construction
  - g. 29 CFR 1926.62 – Lead in Construction Standard
- 8. Society for Protective Coatings (SSPC):
  - a. SSPC-Guide 6, Guide for Containing Debris Generated During Paint Removal Operations
  - b. SSPC-Guide 7, Guide for the Disposal of Lead-Contaminated Surface Preparation Debris
  - c. SSPC-SP 1, Solvent Cleaning
  - d. SSPC-SP 2, Hand Tool Cleaning
  - e. SSPC-SP 3, Power Tool Cleaning
  - f. SSPC-SP 11, Power Tool Cleaning to Bare Metal
  - g. SSPC-SP 13/ NACE No.6, Surface Preparation of Concrete
  - h. SSPC-SP 15, Commercial Grade Power Tool Cleaning
- 9. Underwriters Laboratories, Inc. (UL):
  - a. UL 586 – Standard for Safety High Efficiency, Particulate, Air Filter Units.

1.05 DEFINITIONS

- A. Abatement: Any measures or set of measures designed to permanently eliminate PCB paint/bitumastic coating hazards. Abatement includes, but is not limited to, the removal of PCB paints/bitumastic coatings or the replacement of PCB-painted/bitumastic-coated surfaces or fixtures. Abatement also includes the removal of paints/bitumastic coatings (with a PCB concentration greater than or equal to 50 parts per million (ppm)) when the underlying substrate is to remain in place. Abatement does not include renovation, remodeling,

landscaping, or other activities, when such activities are not designed to permanently eliminate PCB hazards, but instead, are designed to repair, restore, or remodel a given structure or dwelling, even though these activities may incidentally result in a reduction or elimination of PCB hazards. Furthermore, Abatement does not include interim controls (e.g., the spot removal of a PCB paint/bitumastic coating on a surface in order to perform torch cutting at that location), operations and maintenance activities, or other measures and activities designed to temporarily, but not permanently, reduce PCB hazards.

- B. **Area Monitoring:** Stationary air sampling outside of a PCB Control Area for the purpose of determining compliance with OSHA's Limits for Air Contaminants Table (29 CFR 1910.1000, Table Z-1), and for the purpose of ensuring that airborne PCB concentrations remain below 1.0 mg/m<sup>3</sup> (Aroclor 1242) and 0.5 mg/m<sup>3</sup> (Aroclor 1254) outside of the PCB Control Area during all Work activities that have the potential to disturb PCB-Containing Materials with PCB concentrations greater than or equal to 50 parts per million (ppm). Area Monitoring for heavy metals (i.e., arsenic, cadmium, chromium, lead, or mercury) will be required if Exposure Monitoring results exceed corresponding Action Levels, Permissible Exposure Limits (PELs), or Threshold Limit Values (TLVs). If asbestos is present, Area Monitoring shall also be conducted in accordance with DEP (RCNY Title 15, Chapter 1) or NYSDOL (12 NYCRR 56) regulations. All Area Monitoring shall follow pertinent NIOSH or ASTM sampling methodologies.
- C. **Certified Industrial Hygienist (CIH):** Refers to an individual employed by the Contractor who is currently certified by the American Board of Industrial Hygiene (ABIH).
- D. **Competent Person:** Defined by OSHA as someone who is capable of identifying existing and predictable hazards in the surroundings or working conditions, and who has authorization to take prompt corrective measures to eliminate them. Duties of the Competent Person include the following: (a) determining prior to the performance of the Work, whether PCBs, asbestos, or other heavy metals (i.e., arsenic, cadmium, chromium, lead, or mercury) are present in the workplace; (b) establishing PCB Control Areas and assuring that access to and from those areas is limited to authorized personnel; (c) assuring the adequacy of any employee Exposure Monitoring required by OSHA; (d) assuring that all employees exposed to airborne contaminant levels above Action Levels, PELs, or TLVs wear appropriate Personal Protective Equipment (PPE), respiratory protection, and are trained in the use of appropriate methods of exposure control for all of the contaminants present; (e) assuring that proper Hygiene Facilities are provided and that workers are trained to use those facilities; (f) assuring that engineering controls specific to the contaminants present are implemented, maintained in proper operating condition, and functioning properly.

## GENERAL SPECIFICATION 13284 - PCB MANAGEMENT

---

- E. Decontamination Area: Designated area within the Hygiene Facilities for removing gross contamination from PPE (using a HEPA vacuum), washing away contamination that has accumulated on the skin and hair (using soap and water), removing, and disposing/washing of contaminated PPE, and donning clean clothing that will not potentially contaminate areas outside of a PCB Control Area's Physical Boundary.
- F. DOT Hazardous Materials Transportation Training: Training that meets the criteria outlined in 49 CFR 172.704. This training shall include discussions of the following: (a) hazardous materials tables within 49 CFR 172; (b) material packaging and labeling within 49 CFR 178; (c) shipping papers and placards within 49 CFR 173; (d) material loading and segregation.
- G. Exclusion Zone: (See definition of "PCB Control Area").
- H. Exposure Monitoring: Personal air sampling performed outside the respirator within the breathing zone of individuals, for the purpose of determining compliance with OSHA's Limits for Air Contaminants Table (29 CFR 1910.1000, Table Z-1), as well as the DEP EHS Policy and Procedures for PCB Management. Analytical results obtained from Exposure Monitoring will be used to select appropriate respiratory protection and PPE for individuals within a work area. For the purpose of this Section, Exposure Monitoring samples shall be collected from individuals who are representative of each type work task being conducted by the Contractor, and all Exposure Monitoring shall follow pertinent NIOSH (Method 5503) or ASTM sampling methodologies.
- I. Fluorescent Light Ballast: A device that electrically controls fluorescent light fixtures and includes a capacitor containing 0.1 kilograms (kg) or less of dielectric fluid.
- J. Hazardous Waste Operations (HAZWOPER) Training: Training that meets the criteria outlined in the OSHA Hazardous Waste Operations and Emergency Response Standard (29 CFR 1910.120). A minimum of 24-hour HAZWOPER training will be required for Work being performed under this Section. However, certain types of Work may require 40-hour HAZWOPER Training. All decisions regarding the specific HAZWOPER Training that will be required for each Work task shall be made by the Engineer.
- K. High-Efficiency Particulate Air (HEPA) Filter: A filter designed to remove 99.97% of all particles greater than 0.3 micrometers ( $\mu\text{m}$ ) in diameter. For the purpose of this Section, HEPA vacuum and local exhaust filtration equipment used by the Contractor shall meet the Standard for Safety High-Efficiency, Particulate, Air Filter Units (UL 586) developed by Underwriters Laboratories.
- L. Homogenous Materials: PCB-Containing Materials which are similar in appearance, color, texture, and substrate type.

## GENERAL SPECIFICATION 13284 - PCB MANAGEMENT

---

- M. Hygiene Facilities: Facilities within the Physical Boundary of a work area that are set up to prevent cross contamination and are equipped with change areas and separate storage facilities for PPE and clean clothing. Hygiene Facilities shall include adequately supplied hand washing station(s) (i.e., running water, soap, and clean towels) or shower(s) (hot and cold water that is controllable at the tap, soap, shampoo, and clean towels).
- N. Organic Vapor Cartridge: A respirator filter typically containing 25 to 40 grams of sorption media such as activated charcoal.
- O. OSHA Monitoring: (See definition of “Exposure Monitoring”).
- P. P-100 Filter: (See definition of: “High-Efficiency Particulate Air (HEPA) Filter”).
- Q. PCB Awareness Training: Training for individuals that have the potential to be exposed to PCB-Containing Materials or PCB Wastes. This training shall include discussions of the following: (a) sources of PCBs; (b) current federal, state, and local regulations pertaining to PCBs (including 40 CFR 761) and other contaminants that may be disturbed during the Work; (c) the health effects of PCBs and other contaminant exposures; (d) state-of-the-art work practices, engineering controls, and procedures for Abatement, removal, construction/demolition, materials handling, housekeeping, and waste management activities that involve PCB-Containing Materials and PCB Wastes; (e) the use and maintenance of PPE and the use and maintenance of respirators in accordance with 29 CFR 1910.134; (f) medical surveillance programs; (g) requirements regarding warning signs, labeling, and Safety Data Sheets (SDSs) in accordance with 29 CFR 1910.1200; (h) responsibilities of the Competent Person.
- R. PCB Bulk Product Waste: Waste derived from manufactured products containing PCBs in a non-liquid state, at any concentration where the concentration at the time of designation for disposal is greater than or equal to 50 ppm of PCBs.
- S. PCB-Containing Material: Any material that contains, or is coated with, a detectable concentration of PCBs.
- T. PCB Control Area: The area within the Physical Boundary where worker Hygiene Facilities are located and where all Work activities take place that involve the disturbance of PCB-Containing Materials and PCB Wastes.
- U. PCB Hazardous Waste (per NYSDEC): All solid wastes containing PCB concentrations greater than or equal to 50 ppm. Refer to 6 NYCRR Part 371.4(e) for specific details and exceptions regarding the classification of PCB Wastes as “hazardous wastes” (listed waste B001-B007) in New York State.
- V. PCB Waste (TSCA-regulated): Non-specific liquid or solid waste generated during the Abatement, removal, construction/demolition, handling, or cleanup

of a PCB-Containing Material with a PCB concentration greater than or equal to 50 parts per million (ppm). PCB Waste also includes any waste (including remediation waste, polyethylene sheeting and PPE) that has been in contact with a material that has a PCB concentration greater than or equal to 50 ppm, regardless of whether the waste itself has a PCB concentration of less than 50 ppm. PCB Wastes are subject to the disposal requirements set forth in Toxic Substances Control Act (TSCA) (40 CFR 761, Subpart D).

- W. Perimeter Monitoring: (See definition of “Area Monitoring”).
- X. PEL: Defined by OSHA as individual exposure, without regard to the use of respirators, to a specific airborne concentration of a contaminant expressed in milligrams per cubic meter of air (mg/m<sup>3</sup>) calculated as an 8-hour Time-Weighted Average (TWA). Once a PEL is met or exceeded for a particular contaminant, the Contractor is responsible for meeting specific OSHA requirements, which may include worker Exposure Monitoring, the use of PPE including respiratory protection, the use of Hygiene Facilities, medical surveillance, or training for workers. The following PELs are pertinent to disturbance, removal, construction/demolition, and disposal activities associated with PCB-Containing Materials and PCB Wastes: (a) PCB Aroclor 1254 – 0.5 mg/m<sup>3</sup> per 29 CFR 1910.1000, Table Z-1; (b) PCB Aroclor 1242 – 1.0 mg/m<sup>3</sup> per 29 CFR 1910.1000, Table Z-1.
- Y. Personal Monitoring: (See definition of “Exposure Monitoring”).
- Z. Physical Boundary: A physical barrier designated with ropes, “caution tape,” or a partition that surrounds a work area in order to limit the entry of unauthorized personnel and delineate “clean areas” from areas that may meet or exceed an Action Level, PEL, or TLV.
- AA. PCBs: Any group of chlorinated isomers of biphenyl, formerly used in the form of a toxic, colorless, odorless, viscous liquid typically added to lubricants, heat-transfer fluids, and plasticizers.
- BB. Regulated Area: (See definition of “PCB Control Area”).
- CC. Resource Conservation and Recovery Act (RCRA) Training: Training that meets the criteria outlined in 40 CFR 265.16. This training shall include site-specific discussions of the following: (a) hazardous waste identification; (b) waste storage container use and labeling; (c) waste storage area management; (d) personal health and safety, including fire safety; (e) manifesting and the off-site transportation of wastes; (f) procedures for using, inspecting, repairing, and replacing emergency equipment and monitoring equipment; (g) procedures for communicating with other employees and outside emergency response personnel; (h) responses to fires or explosions; (i) responses to leaks, spills, and potential groundwater contamination incidents ; (j) the shutdown of operations.

- DD. Small Capacitor: A device for accumulating and holding a charge of electricity and consisting of conducting surfaces separated by a dielectric fluid in a quantity less than 1.36 kilograms (kg) or three pounds. If the weight of the dielectric fluid is unknown, it can be assumed that a Small Capacitor is a capacitor that has a total volume of less than 1,639 cubic centimeters (cm<sup>3</sup>) or 100 cubic inches (in<sup>3</sup>).
- EE. TWA: The average time over a given work period (e.g., an 8-hour workday) of a person's exposure to a chemical or agent. The average is determined by sampling for the chemical or agent throughout the time period.
- FF. Trigger Activities: Certain activities that involve a disturbance of PCB-Containing Materials or PCB Wastes. Depending upon whether the performance of these activities exceeds an Action Level, PEL or TLV, the requirements may include additional worker Exposure Monitoring, the use of PPE including respiratory protection, the use of Hygiene Facilities, medical surveillance, or training for workers. Examples of Trigger Activities include, but are not limited to, the following: abrasive blasting, welding, torch cutting/burning, heat gun usage, needle gunning/scaling, rivet busting, using a rotopeen, mechanical sanding/grinding, using mechanical shears, hand scraping/sanding, chemical stripping, and the manual demolition of PCB-Containing Materials.

1.06 DESCRIPTION

- A. Commencement of Work: Five (5) business days prior to the proposed start of the work of this Section at each separate location, the Contractor shall notify the Engineer and the onsite safety staff. No Work may proceed at any location until authorized by the Engineer.
- B. The Contractor shall coordinate any required equipment shutdowns with the Engineer prior to starting the Work.
- C. Access Restrictions: The Contractor shall inform the Engineer of proposed access restrictions (i.e., areas or items of equipment which will not be accessible during the proposed Work) and give them estimated time frames (including specific dates) of such proposed access restrictions. The Contractor shall be aware that other contractors may be at any of the work sites associated with this Contract. As a result, the Contractor shall not have exclusive rights to any work site and shall fully cooperate and coordinate this Work with the work of other contractors who may be on site. Therefore, the Contractor shall notify other contractors in advance of the disturbance, Abatement, removal, construction/demolition, and disposal Work included herein, to provide them with sufficient time for coordination of interrelated items that are included in their contracts and that must be performed before, after, or in conjunction with the Work included under this Section.



- D. Unexpected Entry into a PCB Control Area: In the event that DEP personnel must enter a PCB Control Area for reasons unrelated to the supervision or inspection of Work being performed under this Section (e.g., under emergency conditions), the Contractor shall immediately stop Work and cleanup any loose debris, so as to permit the safe entry by DEP personnel. Any disturbance of paints/bitumastic coatings, dusts, materials, or wastes that may potentially generate airborne concentrations of contaminants equal to or above an OSHA Action Level shall not proceed until all DEP personnel have exited from the PCB Control Area.
- E. Meetings: The Contractor shall visit and investigate the site, review the Drawings, review this Section, review DEP EHS Policies and Procedures, and become familiar with any conditions which may affect the Work, as part of the pre-construction meeting and site walk-through. The Contractor shall hold all meetings with appropriate parties as scheduled and as otherwise necessary to accomplish the Work to be performed under this Section. In addition to the pre-construction meeting and site walk-through, other meetings may be required or may be requested by the Engineer, including briefings to Site Operations personnel. Written documentation (i.e., “minutes”) of all meetings shall be generated by the Contractor, and copies shall be provided to the DEP within three (3) business days following each meeting.

1.07 QUALITY ASSURANCE

- A. Scheduling: The Contractor shall coordinate and schedule all phases of the Work to be performed under this Section with the DEP, subcontractors, material suppliers, and other parties as necessary to ensure the proper execution of the Work.
- B. Compliance: In addition to the detailed requirements of this Section, DEP EHS Policies and Procedures, and Section 01356 – Environmental Health and Safety (EHS) Requirements, the Contractor shall comply with all applicable regulations of federal, state, and local authorities pertaining to the disturbance, Abatement, removal, construction/demolition, handling, storage, transportation, and disposal of PCB-Containing Materials and PCB Wastes. All matters regarding the interpretation of any regulations, standards, or policies shall be submitted to the Engineer for resolution before starting the Work. Where the requirements of this Section, DEP EHS Policies and Procedures, or federal, state, or local regulations conflict or vary, the most stringent requirements or regulations shall apply.
- C. Rejection of Non-Complying Items: The DEP reserves the right to reject items incorporated into the Work which fail to meet the specified minimum requirements. The DEP also reserves the right to reject Contractor submittal items that are deemed inappropriate or unacceptable by the Engineer or DEP. Submittal items that may be deemed inappropriate or unacceptable include

- proposed vendors or subcontractors with previous regulatory citations/violations.
- D. Suspect Material Characterization: To classify caulking or a paint or bitumastic coating as non-PCB containing, a paint chip/coating sample must be collected as a grab sample from the source. The sample shall be sent to an analytical laboratory meeting the requirements of this Section.
1. Suspect PCB-Containing Paints/Coatings: Although there are no certification requirements pertaining to an individual that collects paint chip samples in an industrial or commercial setting, this Section requires paint chip sampling to be performed by an individual who has successfully completed HAZWOPER Training and PCB Awareness Training courses (within the past year) as defined in this Section. In addition, the individual shall possess a current EPA Lead Inspector or EPA Risk Assessor certification or have documented experience in collecting paint chip samples.
  2. Suspect ACM: All caulking and bitumastic coatings are considered suspect ACM. Therefore, if a sample will be collected, the sampling shall be performed by a certified DEP Asbestos Investigator or NYSDOL Asbestos Inspector.
  3. The qualifications of individuals who will collect samples must be approved by the Engineer prior to sample collection. Analytical results for samples that are collected by individuals not approved by the Engineer will not be recognized or accepted as valid by the DEP.
  4. Estimate an approximate number of samples to adequately characterize painted/coated surfaces. Collect grab samples that include all layers of paint/coating from different areas randomly dispersed throughout the painted surface area. Grab samples are not to be composited.
  5. PCB concentrations are based on the cumulative total of the nine (9) Aroclor congeners (aka PCB compounds) analyzed by EPA Method SW 846-8082A (soxhlet extraction method 3540) by Gas Chromatography.
- E. Qualifications:
1. The Contractor or their proposed PCB removal subcontractor shall have successfully completed at least two (2) projects of comparable scope and methodologies to the work being performed under this Section within the past three (3) years. This experience shall be documented by identifying the following: (a) the name, address, and phone number of each facility where the work was performed; (b) the name of the individual representing the owner who supervised the work at each facility; (c) the types of facilities where the work was performed; (d) the volume and type of each material that was abated/removed; (e) the

specific methods of Abatement/removal used at each facility (including the tools, technologies, and engineering controls employed).

2. **Competent Person:** When disturbing materials and wastes with PCB concentrations greater than or equal to 50 ppm, the Contractor shall have on staff and assigned to this Contract a Competent Person who has successfully completed DOT Hazardous Materials Transportation Training, HAZWOPER Training, PCB Awareness Training, and RCRA Training courses as defined in this Section. Each training course shall have been completed within the past year in the form of either an initial course or a refresher course. In addition, the Competent Person shall be able to fulfill the duties defined in this Section, shall have a minimum of two (2) years' experience with work involving PCBs, and shall have served as the Competent Person on at least three (3) projects of comparable scope and methodologies to the work being performed under this Section. The Competent Person shall be on site during all PCB-related work activities. It should be noted that depending upon the specific contaminants present during the work, additional training for the Competent Person (as described in Section 13283 - Lead Management) may be required.
3. **PCB Waste Manager:** When disturbing materials and wastes with PCB concentrations greater than or equal to 50 ppm, the Contractor shall have on staff and assigned to this Contract a PCB waste manager who has successfully completed DOT Hazardous Materials Transportation Training, HAZWOPER Training, PCB Awareness Training, and RCRA Training courses as defined in this Section. Each training course shall have been completed within the past year in the form of either an initial course or a refresher course. In addition, the PCB waste manager shall have a minimum of two (2) years' experience on projects involving PCB Wastes. It is acceptable for an individual who meets the criteria of the Competent Person, to also serve as the PCB waste manager for this Contract as long as the individual fulfills all of the requirements of this paragraph.
4. **PCB Worker:** When disturbing materials and wastes with PCB concentrations greater than or equal to 50 ppm, the Contractor shall have on staff and assigned to this Contract a sufficient number of PCB workers who have successfully completed DOT Hazardous Materials Transportation Training and PCB Awareness Training courses as defined in this Section. Each training course shall have been completed within the past year in the form of either an initial course or a refresher course. In addition, each PCB worker shall have a minimum of one (1) year of experience on projects involving PCBs and shall have worked on at least three (3) projects of comparable scope and methodologies to the work being performed under this Section. It should be noted that

depending upon the specific contaminants present during the work, additional training for PCB workers (as described in Section 13283 - Lead Management) may be required.

5. Worker (low PCB concentrations): When disturbing materials and wastes with PCB concentrations less than 50 ppm, the Contractor shall have on staff and assigned to this Contract a sufficient number of workers who have successfully completed a PCB Awareness Training course as defined in this Section. Each training course shall have been completed within the past year in the form of either an initial course or a refresher course. It should be noted that until a negative exposure assessment has been established via Exposure Monitoring, workers must wear appropriate respiratory protection.
6. Air Monitor: When disturbing any detectable concentration of PCBs, the Contractor shall have an Air Monitor assigned to this Contract who has successfully completed a PCB Awareness Training course as defined in this Section. This training course shall have been completed within the past year in the form of either an initial course or a refresher course. In addition, the Air Monitor shall have a minimum of two (2) years' experience in conducting Area Monitoring and Exposure Monitoring on projects involving PCBs. It is acceptable for an individual who meets the qualification requirements for Competent Person or PCB waste manager to also serve as the Air Monitor for this Contract, as long as the individual satisfies all of the requirements of this paragraph.

1.08 SUBMITTALS

- A. Within 30 business days of the "Notice to Proceed" or as directed by the Engineer, the Contractor shall submit the following to the Engineer:
  1. PCB Inspection and Sampling Plan: The Contractor shall provide a PCB Inspection and Sampling Plan to identify suspect PCBs, not otherwise sampled during Design, and collect samples, as appropriate during the inspection. This plan shall include at a minimum:
    - a. Credentials of the individual responsible for inspection and sampling. At a minimum, the inspection shall be performed by an Environmental Professional, as defined in this Contract, who shall have current HAZWOPER training, PCB awareness training, and OSHA 10-hr certification, and shall have performed similar inspection work on at least three (3) projects of similar scope.
    - b. Credentials of the laboratory providing sample analysis. The credentials shall include current certification by the New York

State Department of Health's Environmental Laboratory Approval Program (ELAP).

- c. Sample collection, analysis, and reporting protocol.
  - d. Health and safety protocol for all investigation activities.
2. PCB Inspection Report: The Contractor shall provide a PCB Inspection Report prepared by the Environmental Professional summarizing the results of all inspection activities, and as applicable, a sampling narrative, laboratory data packages, and inventory of all identified suspect and confirmed PCB Containing Materials.
  3. PCB Safe Work Practices: Each Contractor that will disturb PCB-Containing Materials with a PCB concentration less than 50 ppm during the course of Work to be performed under this Section shall submit detailed, project-specific PCB Safe Work Practices designed to protect their workers and control the spread of potential PCB contamination. Work requiring the development of PCB Safe Work Practices includes, but is not limited to, the mechanical disturbance of paints/coatings (e.g., drilling, sawing, or spot removal). The PCB Safe Work Practices shall be signed and dated by a CIH meeting the definition in this Section, and shall include the following elements:
    - a. A detailed discussion regarding the procedures and methodologies that will be used to conduct Exposure Monitoring. Also, provide the name and qualifications (i.e., training and experience documentation) of the Air Monitor who will be responsible for conducting the Air Monitoring activities. The Air Monitor shall at a minimum, satisfy the qualification requirements set forth in this Section;
    - b. A detailed discussion regarding housekeeping procedures to be used for maintaining clean work areas and clean Hygiene Facilities;
    - c. A detailed task analysis for each Work activity that has the potential to disturb PCB-Containing Materials with a PCB concentration less than 50 ppm. Each task analysis shall include, but is not limited to, the following information: (a) the type of Work activity; (b) the tools/equipment that will be used; (c) operation and maintenance practices and procedures that will be used for the tools/equipment (SSPC SP 1, 2, 3, 11, 13 and 15 as applicable); (d) the types of PCB-Containing Materials that may be disturbed when performing the activity; (e) the engineering controls that will be used to control the spread of contamination during the activity; (f) housekeeping procedures that will be

- used during the activity; (g) PPE and proposed respiratory protection that will be used for the activity;
- d. Equipment and Supplies: Identify the equipment and supplies that will be used to perform the Work;
  - e. Rental Equipment Notification: If rental equipment is to be used during the Work, the Contractor shall notify the rental agency in writing concerning the intended use of the equipment. Rental equipment data demonstrating compliance with the performance requirements of this Section must be presented to and approved by the Engineer prior to use;
  - f. SDSs: Provide SDSs for all chemical products to be used for the Work;
  - g. Medical Clearance for Respiratory Protection: For all activities that disturb PCB-Containing Materials with a PCB concentration less than 50 ppm, the Contractor shall provide a sufficient number of properly trained and experienced workers, each of whom shall: (a) have received a medical exam that included a Pulmonary Function Test (PFT) within the past year; (b) have received written medical clearance within the past year, by a licensed physician, to wear a respirator; (c) have received a qualitative or quantitative respirator fit-test for the specific respirator the employee will be using for this Work within the past year;
  - h. Employee Documentation: For all activities that may disturb PCB-Containing Materials with a PCB concentration less than 50 ppm, the Contractor shall provide a sufficient number of properly trained and experienced workers, each of whom shall: (a) have written proof of training (e.g., certificates) in accordance with the qualification requirements of this Section for workers and Air Monitors that will be used for the Work; (b) dates and written proof of respiratory clearance and a medical exam in accordance with this Article; (c) dates and written proof of a respirator fit-test in accordance with this Article.
4. PCB Management Plan: Each Contractor that will disturb PCB-Containing Materials with a concentration of PCBs greater than or equal to 50 ppm, and PCB Wastes during the course of Work to be performed under this Section shall submit a detailed, project-specific PCB Management Plan that addresses work procedures and equipment to be used during the disturbance, removal, handling, collection, and disposal of PCB-Containing Materials and PCB Wastes. Work requiring a PCB Management Plan includes, but is not limited to, Abatement, spot

removal, and construction/demolition activities. The PCB Management Plan shall be prepared in accordance with OSHA Construction Standards and all other pertinent federal, state, and local regulations, including DEP (RCNY Title 15, Chapter 1) or New York State Department of Labor (NYSDOL) (12 NYCRR 56) asbestos regulations if asbestos is present. In addition, the PCB Management Plan shall follow all DEP EHS Policies and Procedures (referenced in this Section) and shall be coordinated with the Engineer. The PCB Management Plan shall also be signed and dated by a CIH meeting the definition in this Section.

- a. If the PCB-Containing Materials or PCB Wastes that will be disturbed also contain asbestos or heavy metals, it is acceptable to integrate the PCB Management Plan elements into the relevant Asbestos Work Plan (required under Section 13281 - Asbestos Management) or Lead Management Plan (required under Section 13283 - Lead Management and SSPC Guide 7). PCB Management Plan elements that are integrated into an Asbestos Work Plan or Lead Management Plan must still satisfy all of the requirements of this Section. The PCB Management Plan (or relevant Asbestos Work Plan or Lead Management Plan) shall include the following elements:
  - 1) PCB Control:
    - a) Drawings showing the location and details of the following: (a) each PCB Control Area; (b) each hygiene facility; (c) proposed electrical hookups; (d) proposed water hookups; (e) each waste storage area; (f) restroom areas; (g) areas designated for eating, drinking, and smoking;
    - b) A detailed discussion regarding the interfacing of trades (i.e., how the Contractor will coordinate the Work with other contractors or DEP employees working at the site) and the sequencing of PCB-related Work;
    - c) A detailed discussion regarding the collection, handling procedures, and disposal of PCB-Containing Materials with a PCB concentration equal to or greater than 50 ppm, and PCB Wastes (including the collection, filtering, and disposal of wastewater). If reusable equipment used during the Work will be in contact with PCB-Containing Materials or PCB Wastes, the Contractor shall submit an equipment

- decontamination procedure using a Performance-based Decontamination Fluid (PODF) in accordance with 40 CFR 761;
- d) A detailed discussion regarding the procedures and methodologies that will be used to conduct Exposure Monitoring and Area Monitoring. Also, provide the name and qualifications (i.e., training and experience documentation) of the Air Monitor who will be responsible for conducting the Air Monitoring activities. The Air Monitor shall at a minimum, satisfy the qualification requirements set forth in this Section;
  - e) A detailed discussion regarding housekeeping procedures to be used for maintaining clean work areas and clean Hygiene Facilities;
  - f) A detailed discussion regarding the specific methods and procedures of emissions control that will be used to ensure that airborne contaminant levels do not meet or exceed an OSHA PEL outside of each PCB Control Area;
  - g) Detailed task analysis for each Work activity that has the potential to disturb PCB-Containing Materials with a PCB concentration equal to or greater than 50 ppm, and PCB Wastes. Each task analysis shall include, but is not limited to, the following information: (a) the type of Work activity; (b) the tools/equipment that will be used; (c) operation and maintenance practices and procedures that will be used for the tools/equipment; (d) the types of PCB-Containing Materials that may be disturbed or PCB Wastes that may be generated when performing the activity; (e) the engineering controls that will be used to control the spread of contamination during the activity; (f) the proposed crew size for the activity and individual employee responsibilities during the activity; (g) housekeeping procedures that will be used during the activity; (h) PPE and proposed respiratory protection that will be used for the activity;



- h) Equipment and Supplies: Identify the equipment and supplies that will be used to perform the Work;
  - i) Rental Equipment Notification: If rental equipment is to be used during the Work, the Contractor shall notify the rental agency in writing concerning the intended use of the equipment. Rental equipment data demonstrating compliance with the performance requirements of this Section must be presented to and approved by the Engineer prior to use;
  - j) SDSs: Provide SDSs for all chemical products (including chemical stripping products and PODFs) to be used for the Work;
  - k) The name and qualifications (i.e., experience and training documentation) of the Competent Person who will be responsible for the oversight and execution of the PCB Management Plan during all activities affecting PCB-Containing Materials with a PCB concentration equal to or greater than 50 ppm, and PCB Wastes. At a minimum, the Competent Person shall satisfy the qualification requirements set forth in this Section.
- 2) Waste Management:
- a) The identification of PCB-Containing Materials with a PCB concentrations equal to or greater than 50 ppm, and PCB Wastes associated with the Work;
  - b) The estimated quantity of each waste stream (regulated and non-regulated) that will be generated and disposed of;
  - c) The name, address, phone number, and qualifications for each vendor and facility that will be transporting, storing, testing, or disposing of the wastes. The Contractor shall verify the permit status of the facility as well as check for outstanding violations and enforcement actions. Include a 24-hour phone contact for each vendor and facility;

- d) Current permit documentation for each recycling and TSDF indicating that the facility is approved by federal, state, and local regulatory agencies to receive PCB-Containing Materials with a PCB concentration equal to or greater than 50 ppm, and PCB Wastes. The documentation shall include an “acceptance letter” from each TSDF indicating its ability to accept the specific waste streams that will be generated during Work performed under this Section;
- e) Current 6 NYCRR 364 permit documentation for the waste transporter that will transport PCB-Containing Materials with a PCB concentration equal to or greater than 50 ppm, and PCB Wastes from the work site to the TSDF. The documentation shall clearly indicate the transporter’s ability to deliver the PCB-Containing Materials and PCB Wastes to the chosen TSDF;
- f) Spill prevention, containment, and cleanup contingency measures to be implemented during the Work, as well as procedures to be followed during a suspected PCB emissions/bulk material release or emergency situation. All measures and procedures shall be in accordance with the standards referenced in this Section;
- g) A detailed discussion of the on-site handling, storage, removal, and disposal of waste materials. This discussion shall include, but is not limited to, the following: (a) specifications for a secondary containment system for each drum storage area; (b) the methods of demarcation that will be used to identify the waste storage areas and each waste container; (c) the methods and procedures that will be used to collect and containerize wastes on a daily basis; (d) the types of containers that will be used to containerize the wastes; (e) the submittal of weekly regulated waste inspection and inventory records as required in this Section;
- h) The name and qualifications (i.e., experience and training documentation) of the PCB waste

manager who will be responsible for the oversight and execution of the PCB Management Plan during waste management activities involving PCB-Containing Materials with a PCB concentration equal to or greater than 50 ppm, and PCB Wastes. At a minimum, the PCB waste manager shall satisfy the qualification requirements set forth in this Section.

- b. A detailed schedule for the implementation of the PCB Management Plan elements. The schedule shall clearly indicate the starting and completion dates for the Work, and shall allow adequate time for cleanup, inspections, and Air Monitoring activities.
- c. Medical Surveillance: For all activities that disturb PCB Containing Materials with PCB concentrations that are greater than or equal to 50 ppm, and PCB Wastes, the Contractor shall provide a sufficient number of properly trained and experienced workers, each of whom shall: (a) have completed initial blood testing for PCBs; (b) have received a medical exam that included a PFT within the past year; (c) have received written medical clearance within the past year, by a licensed physician, to wear a respirator; (d) have received a qualitative or quantitative respirator fit-test within the past year for the specific respirator the employee will be using for this Work.
- d. Employee Documentation: For all activities that result in airborne contaminant concentrations (i.e., PCBs, asbestos, or heavy metals) equal to, or in excess of an Action Level, PEL, or TLV, or for those activities that take place within a PCB Control Area, the Contractor shall provide a sufficient number of properly trained and experienced workers, each of whom shall: (a) have written proof of training (e.g., certificates) in accordance with the qualification requirements of this Section for PCB workers, Competent Persons, PCB waste managers, and Air Monitors that will be used for the Work; (b) copies of resumes for PCB workers, Competent Persons, PCB waste managers, and Air Monitors that will be used for the Work, indicating work experience as required in this Section; (c) dates and written proof of initial medical surveillance by the Contractor or other employer within the past year, and proof that the employee is currently participating in the employer's ongoing medical surveillance program in accordance with this Section; (d) dates and written proof of respiratory clearance and a medical exam in accordance with this Section; (e) dates and

written proof of a respirator fit-test in accordance with this Section.

- e. A current (i.e., within the last month) signed and notarized statement disclosing all OSHA, EPA, and DOT citations/violations within the past three (3) years for the company performing the PCB Abatement.
5. Analytical Laboratory Qualifications for Analyzing Suspect PCB-Containing Materials and Wastes: Submit the name, address, and telephone number of each analytical laboratory selected to perform the analyses of waste samples (solid and liquid), air samples collected for Area Monitoring and Exposure Monitoring purposes, and paint/bitumastic coating samples collected to classify painted/coated surfaces. The analytical laboratory shall be currently accredited by the American Industrial Hygiene Association (AIHA) and the New York State Department of Health's (NYSDOH's) Environmental Laboratory Approval Program (ELAP). Provide copies of current AIHA and ELAP certificates along with dates of accreditation/reaccreditation. ELAP certificates must show evidence of certification for the specific analytical methods that will be used to analyze each type of sample that will be collected.
- B. B. Field Reports and Recordkeeping: During all Work performed under this Section, the Contractor shall maintain and provide the following documentation:
- 1. Air Monitoring Documentation: All PCB Air Monitoring results and daily Air Monitoring reports shall be provided to the DEP as soon as possible, but no later than seven (7) calendar days from the date the samples are collected. The results shall be signed by the laboratory employee who analyzed or supervised the analysis of the samples, as well as the Air Monitor that physically performed the Air Monitoring activities at the work site. All laboratory analytical results shall be accompanied by complete COC documentation.
    - a. Each daily Air Monitoring report shall be signed by the Contractor's employee who generated the report. The content of these reports shall include, but is not limited to, the following information: (a) sample "start" and "stop" times; (b) flow rates (initial and final) for each sample; (c) the total volume of air collected for each sample; (d) sample location descriptions/sample location drawings/names of individuals being sampled; (e) types (i.e., makes and models) of sampling equipment used; (f) types of sample media (i.e., filters and cassettes) used; (g) the most recent calibration dates, along with the calibration results, for the sampling equipment used; (h) the

name of the Air Monitor that conducted the Air Monitoring; (i) dates that the Air Monitoring was conducted; (j) work tasks being performed during the Air Monitoring; (k) unique sample numbers used to identify each sample; and, (l) highlighting of all PEL exceedances.

2. Waste Documentation: Completed and signed waste manifests from TSDFs shall be provided to the DEP as soon as possible but no later than thirty (30) calendar days of disposal. In addition, on-site waste storage areas shall be inspected weekly by the PCB waste manager, who at a minimum shall satisfy the qualification requirements set forth in this Section.
  - a. Each waste storage area inspection shall be coordinated with the Engineer, documented in the form of a written report, and each report shall be signed by the Contractor's employee who generated the report. All reports shall be provided to the DEP within 24-hours of the date the inspection is completed. The content of these reports shall include, but is not limited to, the following information: (a) the name of the individual that conducted the inspection; (b) descriptions of waste streams being stored; (c) types and quantities of waste containers being used; (d) the current disposal status (i.e., when each waste container is scheduled to be removed from the work site) and physical condition of each waste container; (e) the presence/absence of proper labeling for each waste container in accordance with this Section and federal, state, and local regulations; (f) secondary containment systems being used; (g) the methods being used to secure/lock each waste storage area to prevent any unauthorized entry.
  - b. In addition to performing weekly waste storage area inspections, the PCB waste manager shall also maintain an ongoing waste inventory. The waste inventory shall be coordinated with the Engineer, and the content of the inventory record shall include, but is not limited to, the following information: (a) specific dates that each waste container was added/removed from the waste storage area; (b) the full name (printed) and signature of the individual responsible for adding/removing each waste container from the waste storage area.
3. PCB Control Area Inspection Documentation: PCB Control Areas shall be inspected daily by the Competent Person, who at a minimum shall satisfy the qualification requirements set forth in this Section.
  - a. a. Each daily PCB Control Area inspection shall be documented in the form of a written report, and each report shall

be signed by the Contractor's employee who generated the report. All reports shall be provided to the DEP no later than 24-hours after the inspection is completed. The content of these reports shall include, but is not limited to, the following information: (a) the types of work being performed; (b) the names of the PCB workers, Competent Person, PCB waste manager, and Monitor on site, as well as the name of the company each individual is representing; (c) the types of Air Monitoring (i.e., Exposure Monitoring or Area Monitoring) being conducted, and the number of samples being collected for each type of Air Monitoring activity; (d) any non-compliance issues observed (i.e., observations that conflict with the requirements of the Contractor's PCB Management Plan, this Section, DEP EHS Policies and Procedures, or federal, state, and local regulations) along with the corrective actions that were taken to achieve compliance.

4. Contractor Project Record: The Contractor's Competent Person shall maintain a project record at the work site. The Contractor Project Record shall be made available to the Engineer or DEP for review at any time during the Work and shall be submitted to the DEP within 24-hours after the completion of the Work.
  - a. At a minimum, the Contractor Project Record shall contain the following information: (a) copies of training certificates for all individuals involved with the Work; (b) copies of all Air Monitoring results generated during the Work; (c) copies of all available caulking and paint chip/bitumastic coating sample analytical data and survey reports related to the Work; (d) copies of all daily sign-in sheets as required in this Article; (e) a list of emergency phone numbers, including the local fire department, local police department, nearest hospital, as well as phone numbers for the Engineer and DEP personnel responsible for administering the Work; (f) a copy of 40 CFR 761; (g) copies of all SDSs pertaining to all chemicals being used during the Work; (h) a copy of this Section and the related Drawings; (i) a copy of the Contractor's PCB Management Plan; (j) copies of all daily PCB Control Area inspection records; (k) copies of all weekly waste storage area inspection records; (l) a copy of the waste inventory; (m) copies of all DEP EHS Policies and Procedures referenced in this Section (n) a copy of the Contractor's Hazard Communication (HAZCOM) program.
5. Daily Sign-In Sheets: The Contractor shall generate daily sign-in sheets for all individuals entering and exiting each PCB Control Area for the duration of the Work. The daily sign-in sheets shall be maintained by

the Competent Person and shall be made available to the Engineer or DEP for review at any time during the Work. All daily sign-in sheets shall be submitted to the DEP within 24-hours after the completion of the Work.

- a. At a minimum, each daily sign-in sheet shall include: (a) the individual's full name (printed); (b) the individual's signature; (c) the name of the company the individual is representing; (d) the time of entry and exit from each PCB Control Area; and (e) verification by the Competent Person that the individual meets the applicable training requirements, if the individual intends to enter a PCB Control Area.
6. HAZCOM Program: The Contractor's HAZCOM program shall be made available to the Engineer or DEP for review at any time during the Work.

## PART 2 PRODUCTS

### 2.01 MATERIALS

- A. Respirators: The Contractor shall select respirators approved by the NIOSH for use in areas where paints/bitumastic coatings, dusts, materials, or wastes containing contaminants may be disturbed. At a minimum, the Contractor shall provide each individual with a half-face, negative pressure, air purifying respirator equipped with HEPA/P-100 Filter cartridges and Organic Vapor Cartridges, until Exposure Monitoring results indicate that respiratory protection can be modified. The Contractor's CIH shall make all determinations regarding respiratory protection modifications that will be implemented for the Work. All modifications shall be in accordance with OSHA requirements, the Contractor's PCB Management Plan, and any relevant Asbestos Work Plan or Lead Management Plan associated with the Work.
- B. PPE: The Contractor shall provide personnel who have a potential to be exposed to materials or wastes containing contaminants, with appropriate PPE as prescribed by the Contractor's CIH.
- C. HEPA Filters: HEPA/P-100 Filters used in vacuuming equipment, power tools, and local exhaust equipment must meet or exceed any manufacturer's specifications and recommendations, as well as specifications presented in the Standard for Safety High Efficiency, Particulate, Air Filter Units (UL 586).
- D. Waste Containers: Containers for the storage of all PCB Wastes shall be DOT-approved and shall be provided by the Contractor.
- E. Abrasives: Mechanical paint/bitumastic coating removal equipment shall not use any products containing crystalline silica, and the equipment shall not utilize any non-recoverable materials or any cutting materials which introduce toxic or hazardous materials into the environment.

- F. Chemical Strippers: The Contractor shall utilize an environmentally safe chemical paint stripping system, with demonstrated suitability and efficiency in preparing cast-in-place concrete, cement, and plaster surfaces that are free of any visible residues of paints/bitumastic coatings. The system shall include non-alkaline or alkaline strippers that provide the lowest possible level of toxicity consistent with the types of paints/bitumastic coatings to be removed. Neutralization products and procedures shall be provided for all alkaline stripping systems, no stripping system shall contain methylene chloride, and the stripping system shall be low in volatile organic compounds (VOCs).

**PART 3 EXECUTION**

**3.01 PREPARATION**

- A. Hygiene Facilities: The Contractor shall provide functional Hygiene Facilities as defined in this Section that are appropriate for the types of Work to be performed under this Section. The Contractor shall ensure that employees do not leave a PCB Control Area wearing any potentially contaminated PPE. Using compressed air to dislodge dust from clothing/PPE shall be strictly prohibited. The Contractor shall collect, test, and properly dispose of all wastewater generated from Hygiene Facilities.
  - 1. Handwash Stations: The Contractor shall provide functioning handwash stations on all projects that disturb PCB-Containing Materials with a PCB concentration equal to or greater than 50 ppm, or PCB Wastes. Handwash stations shall have running water at the tap, clean towels, and soap per 29 CFR 1926.51. Substituting “hand wipes” in place of soap and running water will not be acceptable.
  - 2. Showers: The Contractor shall provide shower facilities for use by employees whose airborne exposure to PCBs is above an OSHA PEL. When shower facilities are necessary, employees are required to shower at the end of the work shift each day prior to leaving the PCB Control Area that they are working in.
- B. Utilities: The temporary use of any on-site utilities shall be subject to the approval of the DEP. The Contractor shall furnish all water and hoses needed for the Work, as well as any temporary hookups. Also, the Contractor shall supply all heating equipment and water filtration devices needed for the Work. In addition, all temporary lighting and temporary electrical service to a PCB Control Area shall be provided by the Contractor and shall be in weather-proof enclosures and be ground fault protected.
- C. Signs: The Contractor shall post conspicuous warning signs at all approaches to work areas and waste storage areas. The signs shall be located at such a distance so that personnel may read the sign and take the necessary precautions before entering a work area or waste storage area. Signs shall comply with



federal, state, and local regulations, including the requirements of OSHA. Signs shall not be removed until all Abatement, removal, and construction/demolition activities have been completed. At a minimum, each sign shall bear the following information in English and the predominant language that is spoken by the Contractor's employees if English is not spoken:

**WARNING**  
**PCB WORK AREA**  
**POISON**  
**NO SMOKING OR EATING**

1. Each sign shall be appropriately modified to include additional warnings for other contaminants that are identified during Exposure Monitoring.
- D. Physical Boundary Delineation: The Contractor shall clearly delineate each work area and waste storage area with a Physical Boundary as defined in this Section.
- E. Work Area Preparation: The Contractor shall utilize HEPA-filtered vacuums, and wet methods during the initial cleaning of each work area. Prior to removal from each work area, all movable objects and mounted objects that can be removed shall be pre-cleaned using HEPA-vacuums and wet methods. Fixed objects that must remain within each work area shall be pre-cleaned using HEPA vacuums and wet methods, and subsequently covered with 6-mil polyethylene sheeting.
- 3.02 AIR MONITORING
- A. Exposure Monitoring: For Work involving the disturbance of any detectable concentration of PCBs, the Contractor shall collect personal air samples from employees who are anticipated to have the greatest risk of exposure, as determined by the Contractor's CIH or Competent Person. Personal air samples shall be collected during every work shift from at least one (1) employee that is representative of each type of work task that is being performed. Each personal air sample shall "run" for the employee's entire work shift in order to ensure that enough volume (of air) is collected, and an accurate 8-hour TWA can be calculated. Documentation regarding the sample numbers, specific shift when the sampling was conducted, the work tasks that were sampled, the dates of sampling, the employee hours that were worked during the shift, and the total sampling times, shall accompany each laboratory COC form.
1. If PCB concentrations being disturbed are less than 50 ppm, Exposure Monitoring may be discontinued following a complete negative exposure assessment and approval from the Engineer and the

Contractor's CIH. A negative exposure assessment is defined as current initial exposure monitoring using breathing zone air samples representing the 8-hour TWA exposure for each individual who are representative of each task being conducted. Following discontinuation of exposure monitoring, if there is a change to work practices, exposure monitoring shall again be performed until a second negative exposure assessment is conducted and analyzed.

- B. **Area Monitoring:** If PCB concentrations being disturbed are greater than or equal to 50 ppm, the Contractor shall collect a minimum of two (2) area air samples outside of each PCB Control Area on a daily basis for the duration of the Abatement, removal, or construction/demolition Work, as well as any other Work involving the disturbance of PCB-Containing Materials or PCB Wastes. During sampling activities, all air sample filter cassettes shall be positioned approximately five to six feet above the ground (in order to simulate an individual's breathing zone) and shall not be placed immediately adjacent to obstructions (e.g., walls or columns) which may restrict the flow of air to the filter cassettes. Each air sample shall be analyzed for all contaminants identified during the exposure assessment. If area Air Monitoring indicates an emission level in excess of an OSHA PEL outside of a PCB Control Area, all Work in that area shall be stopped immediately. The Contractor shall then take immediate corrective actions to reduce emission levels to below the OSHA PEL(s), and the Contractor shall clean all adjacent areas that may have become contaminated due to the emissions. Documentation regarding the sample numbers, sample locations, the dates of sampling, the employee hours that were worked during the shift, and the total sampling times, shall accompany each laboratory COC form.
- C. **Documentation:** Complete documentation of all Air Monitoring activities shall be in accordance with this Section.
- D. The Contractor shall submit all Air Monitoring results to the DEP as soon as possible, but no later than seven (7) calendar days from when the air samples were collected.

### 3.03 BULK REMOVAL

- A. **Protection of Existing Work to Remain:** All Work involving the disturbance of PCB-Containing Materials and PCB Wastes must be conducted without damage to, or contamination of equipment or surfaces within the work areas or other areas adjacent to the work areas. All such damage or contamination shall be immediately corrected and cleaned up by the Contractor at the Contractor's expense.
- B. **Prohibited Activities:** Contractors shall not conduct activities that are prohibited by OSHA and EPA regulations. The following activities are prohibited, regardless of whether they are conducted subject to an exposure assessment and

written compliance program: (a) burning-off paints/bitumastic coatings; (b) using heat guns operating above 1100o F; (c) dry machine sanding, grinding, or blasting paint without a HEPA vacuum exhaust tool; (d) uncontained hydroblasting or high-pressure washing; (e) welding painted/coated surfaces unless the paint/coating is removed at least 4-inches from area of heat application (per 29 CFR 1926.345(c)(1)), and local exhaust ventilation is used.

- C. Test Patches: Prior to choosing the paint removal method(s) for paints/bitumastic coatings, the Contractor shall perform test patches on surfaces subject to Abatement or spot removal, to determine if the method(s) meet the requirements of this Section
- D. Mechanical Removal Equipment: The use of mechanical equipment to remove asbestos-containing caulking or bitumastic coatings will require compliance with DEP (RCNY Title 15, Chapter 1) or NYSDOL (12 NYCRR 56) asbestos regulations, including the use of a full containment enclosure under negative air pressure.
  - 1. When removing paints/bitumastic coatings from metal surfaces, the paints/bitumastic coatings must be removed to the extent that only the bare metal remains (i.e., no mill scale remains). In the case of substrates other than metal (e.g., concrete, brick, and block), paints/bitumastic coatings shall be removed from the surface of the substrate to the extent that flaking and peeling will not occur subsequent to the performance of the Work. Acceptance of the Work shall be contingent upon inspection of the substrate surfaces by the Engineer and must demonstrate the absence of residual paint/coating layers that can be physically measured, pried loose, or peeled away using a scraping device. The Contractor may only use products and tools meeting the performance specifications outlined below:
    - a. The Contractor shall utilize a vacuum-assisted power tool system with demonstrated suitability and efficiency in preparing metal surfaces to the SSPC SP-11 standard, and with demonstrated effectiveness in maintaining PCB emissions below OSHA exposure limits during the disturbance of paints/bitumastic coatings. Such systems may include dustless needle guns, dustless rotopeens, and dustless right-angle grinders, all of which capture dust and debris at the cutting tool edge, and transport the material under vacuum conditions to an air-tight disposal container. Dustless needle guns shall only be utilized on metal surfaces.
    - b. The vacuum-assisted power tool system shall also be designed to permit the removal and replacement of collection containers under negative pressure in order to prevent the release of dusts.

The system shall be equipped with an automatic “shut-off” in the event of vacuum failure.

- c. Abrasive/recovery tools shall be monitored at all times by a device capable of determining recovery at the face of each tool, and capable of automatically disabling the tool in the event that recovery levels are insufficient. The monitor, at a minimum, shall have the following features: (a) a remote warning light; (b) an adjustable recovery set point; (c) automatic equipment disabling capabilities; (d) a sensing range of 0.5 pounds per square inch (psi); (e) solid state photohelic instrumentation; (f) remote sensing at the face of the tool.
  - d. The safe recovery point shall be calibrated each day before start-up, or each time a new tool or vacuum source is used. All manufacturer recommendations shall be followed with respect to the set up and use of the monitor, and the manufacturer's operations manual shall be kept on site at all times. A daily log shall be maintained by the Contractor, identifying all calibrations of recovery levels, as well as any “down time” as a result of insufficient recovery levels.
  - e. The cutting head of the vacuum-assisted power tool system that is used on flat surfaces shall be capable of cutting to within 1-1/2" of any inside corner, molding, or edge, and may include dustless rotopeens or dustless needle guns. Tools for corners and moldings shall be specifically designed for that purpose, and conform to all inside corners, outside corners, curved, flat, and angled surfaces that are to be abated under this Section. These tools shall also maintain vacuum control at the Work surface/cutting head interface at all times. HEPA vacuum-shrouded needle guns may be used for non-flat surfaces in accordance with manufacturer recommendations. Vacuum-assisted finishing tools, such as right-angle grinders, may be used to achieve the SSPC SP 11 standard, but may not be used for primary removal.
  - f. Vacuum-assisted power tool systems meeting all of the specifications outlined herein, may be used pending the submittal of all required performance documentation, and their acceptance by the Engineer. Any tools which do not meet all of the specifications outlined herein, shall be removed from the project site immediately, and shall not be used for the Work to be performed under this Section.
- E. Chemical Strippers: Acceptance of the Work shall be contingent upon inspection of the abated substrate surfaces by the Engineer and must

demonstrate the absence of residual paint/bitumastic coating layers that can be physically measured, pried loose, or peeled away using a scraping device. The Contractor may only use products and paint stripping systems meeting the performance sections outlined below:

1. The Contractor shall utilize a chemical paint stripping system with a demonstrated effectiveness in maintaining PCB emissions below OSHA exposure limits during the disturbance of paints/bitumastic coatings. The Contractor shall utilize a mechanical ventilation system during the Work that exhausts away from occupied areas. The application of all paint stripping systems shall be in accordance with manufacturer recommendations.
2. The Contractor should note that more than one (1) product may be required to strip PCB-containing paints/bitumastic coatings. The use of multiple products shall be in accordance with work practices approved by the individual manufacturer of each chemical paint stripping compound.
3. All chemical paint stripping products shall be presented to the Engineer for approval prior to the start of any Work to be performed under this Section. When presenting the products to the Engineer, they shall be in the manufacturer's unopened, original containers bearing accurate information regarding the products. Also, the manufacturer's labels on each container shall be intact and legible.
4. Chemical paint stripping systems meeting all of the requirements outlined herein, may be used pending the submittal of all required performance documentation, and its acceptance by the Engineer. Any products which do not meet all of the specifications outlined herein, shall be removed from the project site immediately, and shall not be used for the Work to be performed under this Section.

### 3.04 CLEANUP AND DISPOSAL

- A. Cleanup: The Contractor shall maintain all surfaces, including protective coverings (polyethylene sheeting) within each work area, free of accumulations of paint chips/coating debris, dusts, and wastes. The Contractor shall perform housekeeping activities daily throughout each work shift and at the end of each work shift, in order to prevent any accumulation of paint chips/coating debris, dusts, and wastes in the work areas. Dry sweeping and using compressed air to cleanup a work area shall be strictly prohibited. HEPA-filtered vacuums and wet methods shall be used to ensure that each work area remains free of visible paint chips/coating debris, dusts, and wastes. Perform work in accordance with SSPC Guide 6.
- B. Equipment Decontamination: All reusable equipment (e.g., hand tools and power tools) that has been in contact with materials that have a PCB

concentration greater than or equal to 50 ppm and PCB Wastes, shall be thoroughly decontaminated prior to being removed from the PCB Control Area in accordance with 40 CFR 761.79(c)(2)(i), which permits “swabbing surfaces that have contacted PCBs with a solvent.” The solvent shall be a PODF as defined in 40 CFR 761.79(c)(3)(iv)(C) or (D). Used decontamination materials (e.g., rags used to swab equipment) shall be collected, stored, and disposed of in accordance with this Article.

- C. Sampling and Laboratory Analysis of PCB-Containing Wastes: For PCB Waste characterization, the PCB waste manager shall sample all potential PCB-containing waste streams in accordance with the TSCA (40 CFR 761). According to the EPA, characterizing PCB-containing waste streams (i.e., determining whether wastes are regulated or non-regulated under TSCA) shall be made based upon the total PCB concentration at the “source” (e.g., the paint/bitumastic coating) prior to any disturbance that may be initiated through Abatement, removal, or construction/demolition activities. Unlike hazardous waste determinations that are made under RCRA (40 CFR 260 and 40 CFR 261), sampling to determine whether a waste is TSCA-regulated shall not be made based on the sampling and analysis of mixed bulk waste materials/debris generated as a result of Abatement, removal, or construction/demolition activities. Instead, source materials for PCBs must be collected as grab samples and must not be composited during collection or analysis as that may reduce the concentration of PCBs detected. Rather, individual source samples shall be submitted for analysis to determine the highest concentration of PCBs contained in the source material or wastes.
1. PCB concentrations are based on the cumulative total of the nine (9) Aroclor congeners (aka PCB compounds) analyzed by EPA Methods SW 846-8082A (soxhlet extraction method 3540) by Gas Chromatography.
  2. If PCB concentrations in paints/coatings are present greater than or equal to 50 ppm, all PCB-containing waste generated during paints/coatings disturbance will be classified as TSCA-regulated PCB waste. If PCB concentrations in paints/coatings are less than 50 ppm, all PCB-containing waste generated in the area will be classified as non-TSCA PCB-containing waste.
  3. If it cannot be confirmed that the source of drummed waste (e.g., paints/coatings) is non-TSCA-regulated, or no source samples are available, or the soxhlet extraction method 3540 was not used for previous analyses, then four (4) biased worse-case grab samples shall be collected from the drum and each sample analyzed for Total PCBs. If any one grab sample result has a PCB concentration of equal to or greater than 50 ppm, the drummed waste shall be characterized as TSCA-regulated waste.

4. Waste materials/debris generated during Abatement, removal, or construction/demolition activities may be classified as RCRA or NYSDEC hazardous waste (6 NYCRR Part 370 and 6 NYCRR Part 371.4(e)) in addition to being TSCA-regulated. Therefore, wastes/debris must still be sampled and characterized prior to disposal. All waste samples shall be collected in the presence of the Engineer using the following procedure:
  - a. Sampling of drummed waste will be biased for the worst-case (highest result) and will be based on inspection of drum contents. For drums with paint chips, with or without stripper waste, collect one grab sample for every quarter of the drum, from any hot spots (i.e., paint chips). As an example, if the drum is full, collect four grab samples, if the drum is half-full, collect two grab samples, and if the drum is one-tenth full, collect one sample. Grab samples shall be composited into one (1) bulk composite sample. For drums with PPE, polyethylene sheeting, rags, and towels, collect up to four (4) grab samples with positive bias for paint chips or paint-related staining. As such, samples are likely to be collected from dust or chips at the bottom of the drum. Each grab sample shall be composited into one (1) bulk composite sample, labeled, and submitted to a laboratory that satisfies the requirements set for in this Section. Composite samples shall undergo Toxicity Characteristic Leaching Procedure (TCLP) analysis for the eight (8) RCRA metals and Total PCBs to determine if waste is a NYSDEC hazardous waste (i.e., listed waste B007).
  - b. The Contractor shall also direct the laboratory to analyze each sample for any additional parameters that are required by the specific TSDf being used. Furthermore, if the waste stream is associated with the use of a chemical paint stripping system, the Contractor shall have the laboratory analyze each sample for pH and any other RCRA characteristic that may fail due to the chemical composition of the waste. The Contractor shall ensure that the laboratory being used to satisfy the requirements of this Section is also capable of performing these additional analytical tests.
  - c. One (1) representative wastewater sample shall be collected for laboratory analysis from each drum generated. Each sample shall be collected using appropriate field sampling equipment (e.g., a pipette or bailer), and shall be labeled and submitted to a laboratory that satisfies the requirements of this Section.

- D. Sampling and Laboratory Analysis of PCB-Containing Demolition Debris: The Contractor shall collect representative bulk samples of anticipated demolition wastes to determine proper disposal. In addition to a total PCB analysis of the source materials (e.g., paints/bitumastic coatings), representative bulk samples shall be collected from painted/bitumastic-coated building materials for TCLP analysis for the eight (8) RCRA metals and Total PCBs to determine if waste is a NYSDEC listed hazardous waste (i.e., listed waste B007).
1. Scrap Metal Exemption for Recycling: Under 6 NYCRR Part 371.1(c)(7), painted scrap metal can be sent to a recycling facility, rather than be discarded as hazardous waste. In order for the DEP to submit a “c7 notification” to the NYSDEC and claim the “scrap metal exemption,” the Contractor must first submit notification to their recycling facility indicating that PCBs are present on the scrap metal in concentrations less than 50 ppm. If concentrations are greater than or equal to 50 ppm, the scrap metal cannot be recycled and instead must be disposed of as a TSCA-regulated waste. If Lead or other heavy metals are detected in the paints/bitumastic coatings on the scrap metal, the Contractor shall also disclose this information to the recycling facility. The Contractor shall receive written permission from the recycling facility indicating that the facility will accept the PCB paint/bitumastic coated scrap metal generated during the Work to be performed under this Section. The Contractor shall submit this documentation to the Engineer for approval prior to disposal.
  2. Bulk demolition debris (e.g., painted concrete) that is sampled and determined to be non-RCRA-regulated and non-TSCA-regulated waste may be disposed of as construction and demolition (C&D) debris as per Section 01733 – Construction Waste Management and Section 02222 – Demolition and Removals.
- E. Collection, Separation, and Containerization of Wastes: The Contractor shall collect, separate (by waste stream/waste type), and containerize PCB containing wastes (solid and liquid), debris, PPE, and containment materials on a daily basis in accordance with the PCB Safe Work Practices or PCB Management Plan.
1. If any source sample from a specific work area indicates that PCBs in paints/coatings are greater than or equal to 50 ppm, then all waste from that area will be characterized as TSCA-regulated waste. All waste streams must be segregated into separate drums and labeled with PCB waste labels, including out of service date (when PCB waste is first placed in the drum) in addition to RCRA hazardous waste labels (pending analysis). This may include one or more drums for paint chips, chemical stripper waste, and HEPA filters associated with HEPA vacuums. Other waste such as PPE, rags and polyethylene sheeting from a specific work



area may be comingled in drums separate from the drums containing paint chips, stripper waste and HEPA filters.

2. If all source samples from a specific work area indicate that PCBs in paints/coatings are less than 50 ppm, then all PPE, poly and paint/coating waste from that area will be characterized as PCB-containing non-hazardous or hazardous waste pending TCLP analysis of the eight (8) RCRA metals in the waste stream and should not be managed as C&D debris. Drums should be labeled with RCRA hazardous waste labels (pending analysis). All waste streams shall be segregated into separate drums. Paint chips and HEPA filters shall be drummed as one waste stream from each work area, and polyethylene sheeting, rags, paper towels and PPE from each work area will be drummed as a separate waste stream.
  3. The Contractor shall store all wastes in DOT-approved container systems. No drum/container shall be filled in excess of the capacity marked on the drum/container. All drums/containers shall be sealed and covered immediately after filling, and each drum/container shall have a label affixed to it in accordance with the requirements of this Section. All labels shall remain intact and legible at all times.
  4. No water mixed with or contaminated by hazardous waste may be released onto the ground or into any drain or sewer. It should be noted that a discharge of more than 1 lb. of PCBs onto the ground or into the water within a 24-hour period, shall be considered a violation of the Clean Water Act and shall be treated as a “reportable quantity” in accordance with 40 CFR 116, 40 CFR 117, and 40 CFR 302. Such a release shall be grounds for immediate termination of this Contract, and the Contractor shall be liable for any fines, penalties, or remediation costs.
  5. The Contractor shall store non-hazardous wastes separately from hazardous wastes and TSCA-regulated wastes, shall provide all non-hazardous waste containers, and shall make all transportation and disposal arrangements for non-hazardous wastes in accordance with federal, state, and local regulations. TSCA-regulated PCB waste must be disposed within 180 days subject to the requirements of 40 CFR 761.65, in addition to any RCRA hazardous waste storage requirements (i.e., 90 days), as applicable.
- F. **Storage of Wastes:** The Contractor shall ensure that all drummed wastes are stored in a secondary containment system, and that each waste storage area is demarcated with a Physical Boundary. In addition, the Contractor shall post weekly waste inspections and waste inventories in the regulated waste storage area, as required in this Section, as well as the following emergency information in accordance with DEP EHS Policies and Procedures: (a) the name and

## GENERAL SPECIFICATION 13284 - PCB MANAGEMENT

---

telephone number of the facility's Emergency Coordinator; (b) the location of fire extinguishers and fire alarms; (c) the location of spill control materials; (d) the telephone number for the fire department (unless the facility has a direct alarm).

- G. Labeling: The Contractor shall affix warning labels to all PCB Waste and hazardous waste drums/containers. Labels must be filled out completely at the point of generation when waste is first containerized. Labels shall comply with the requirements of federal, state, and local regulations. PCB labels shall be used to designate PCB waste, including out-of-service date, in addition to RCRA hazardous waste labels. At a minimum, all PCB and hazardous waste labels shall bear the following information in English:

CAUTION  
CONTAINS PCBs  
A toxic environmental contaminant requiring  
special handling and disposal in accordance with  
U.S. Environmental Protection Agency Regulations  
40 CFR 761 – For Disposal Information contact  
the nearest U.S. EPA Office  
[Out-of-Service Date – when PCB waste is first  
placed in drum]

HAZARDOUS WASTE  
FEDERAL LAW PROHIBITS IMPROPER DISPOSAL

HANDLE WITH CARE

[Generator Name, Address, and Telephone Number]  
[Specific Contents of Container]  
[EPA-Issued Generator Identification Number]  
[EPA Waste Identification Number]  
[Accumulation Start Date]  
[Accumulation End Date]

1. Since waste classification is pending analysis for RCRA/NYSDEC hazardous waste, the RCRA hazardous waste labels shall indicate "PCB/Hazardous Waste - Pending Analysis."
- H. Disposal of Wastes: All waste profiles for containerized wastes must be reviewed by the Engineer and signed by the DEP as the generator of the waste streams. The Contractor shall notify the DEP at least 14 business days prior to the removal of any waste drums/containers, so that the DEP can inspect the drums/containers and the waste manifests. As per 40 CFR Part 761.207, a

## GENERAL SPECIFICATION 13284 - PCB MANAGEMENT

---

Uniform Hazardous Waste Manifest shall be completed for TSCA-regulated and/or NYSDEC hazardous wastes. Wastes shall be disposed of to ensure that drums/containers do not remain on the job site for more than 90 calendar days from the initial “accumulation start date” on the label affixed to the drum/container. Containers that have reached their storage capacity shall not remain on site, and transportation arrangements shall be made for their immediate removal.

1. Small Capacitors and Fluorescent Light Ballasts: Small Capacitors and Fluorescent Light Ballasts are not classified as hazardous wastes under NYSDEC regulations (6 NYCRR 371.3(e)). However, these items are assumed to contain PCBs, and therefore must be disposed of as PCB Bulk Product Wastes unless marked “No PCBs” by the manufacturer. Small Capacitors and Fluorescent Light Ballasts that are not marked “No PCBs” or are leaking (regardless of PCB concentration), must be managed at one of the following facilities in accordance with 40 CFR 761.62(a): (a) in facilities using a TSCA-approved incinerator; (b) at a TSCA/RCRA-permitted landfill; (c) in facilities using an approved alternate method of destroying PCBs; (d) at a facility using an approved method of removing/decontaminating PCBs; (e) using a TSCA PCB Coordinated Approval issued by the EPA Regional Administrator.
- I. Disposal Documentation: The Contractor shall submit written evidence that the TSDF receiving PCB Wastes is approved by federal, state, and local regulatory agencies to receive TSCA-regulated wastes. If asbestos or heavy metals (as defined in Section 13281 - Asbestos Management and Section 13283 - Lead Management) were detected in the wastes, the Contractor shall also ensure that the TSDF is approved by federal, state, and local regulatory agencies to receive these wastes. Once all waste profiles have been completed, the Contractor shall provide the DEP a “Letter of Approval” issued from the TSDF indicating that the wastes will be accepted. The Contractor shall submit to the DEP one (1) copy of the completed manifest that has been signed and dated by the initial transporter and TSDF in accordance with 6 NYCRR 372, 6 NYCRR 373, 40 CFR 262, 40 CFR 263 and 40 CFR 264. All waste profiles, manifests, and Land Disposal Restrictions (LDRs) must be signed by a DEP employee as per 40 CFR 268 and 6 NYCRR 376, and as described in Section 01355 - Hazardous Materials Control.

END OF SECTION

NO TEXT ON THIS PAGE

**SECTION 13851  
Fire Detection and Alarm System**

**PART 1 GENERAL**

**1.01 SECTION INCLUDES**

- A. The Contractor shall furnish and install a fire detection and alarm system to include Fire Alarm Control Panels, Fire Command Center, smoke and heat detectors, horns with strobe lights, manual pull stations, etc. which when installed shall provide a fully functional system. In addition, the Contractor shall furnish and install properly sized fused disconnecting switches (fused cutouts) and wiring as required for the power portion of the fire alarm system.
- B. An index of the Articles in this Section is presented hereinafter for the convenience of the Contractor.

<u>Article</u>	<u>Title</u>	<u>Page</u>
		13851-
PART 1	GENERAL.....	1
1.01	SECTION INCLUDES.....	1
1.02	Payment.....	2
1.03	Related Sections.....	2
1.04	References.....	2
1.05	Coordination.....	2
1.06	System Requirements.....	3
1.07	Design Requirements.....	4
1.08	Submittals.....	7
1.09	Guaranty.....	8
1.10	Post Contract Maintenance.....	8
1.11	Quality Assurance And Qualifications.....	9
1.12	Spare Parts.....	9
PART 2	PRODUCTS.....	10
2.01	Manufacturers.....	10
2.02	Equipment And Material, General.....	10
2.03	Conduit And Wire.....	10
2.04	Fire Alarm Control Panels And Fire Command Center.....	12
2.05	Network Monitoring Devices.....	21
2.06	System Components - Conventional.....	22
2.07	System Components, Intelligent.....	23
2.08	Batteries And External Charger.....	28
2.09	Painting.....	28
2.10	Electrical Work.....	28
PART 3	EXECUTION.....	28
3.01	Installation.....	28

**GENERAL SPECIFICATION 13851 - FIRE DETECTION AND ALARM SYSTEM**

---

3.02 Typical Operation .....29  
3.03 Testing.....29  
3.04 Final Inspection.....30  
3.05 Instruction .....30

1.02 PAYMENT

- A. Unless otherwise provided in the Detailed Specifications, no separate payment will be made for performing any Work required under this Section and the Contractor shall include all costs thereof in its lump sum price bid for the Contract.

1.03 RELATED SECTIONS

- A. General Specification 09900 - Painting

1.04 REFERENCES

- A. The publications listed below form a part of this Section. The publications are referenced in text by the basic designation only.
  - 1. The fire alarm system shall comply with requirements of NFPA Standard No. 72 for protected premises signaling systems except as modified and supplemented by this Section. The system field wiring shall be supervised either electrically or by software-directed polling of field devices.
  - 2. Local and State Building Codes.
  - 3. All requirements of the Authority Having Jurisdiction (AHJ).
  - 4. The Video Display Terminal (VDT) shall comply with Swedish magnetic emission and X-radiation guidelines MPR 1990:10.
- B. The system must have proper listing and/or approval from the following nationally recognized agencies:
  - 1. UL - Underwriters Laboratories, Inc.
  - 2. FM - Factory Mutual.
  - 3. MEA - Material Equipment Acceptance (NYC).

1.05 COORDINATION

- A. Review installation procedures under other Sections and Contracts and coordinate them with the work specified herein.
- B. Notify the Engineer and other contractors in advance of installation of the work included herein to provide them with sufficient time for the installation and coordination of interrelated items that are included in their Contracts and that must be installed in conjunction with the work included in this Section.
- C. The Contractor shall be responsible for obtaining approval from responsible New York City agencies and the Engineer prior to purchasing and installing the systems. The

Contractor shall provide the appropriate drawings with PE stamps for the Fire Department submittal, and shall be responsible for all required filings/forms, inspections and final approvals required by the NYC agencies.

- D. All wire, conduits and connections for the Fire Alarm System power supply shall be provided by this Contractor as required.

1.06 SYSTEM REQUIREMENTS

- A. This Section includes the furnishing, installation, connection and testing of the microprocessor controlled, intelligent reporting fire alarm network equipment required to form a complete, operative, coordinated system. It shall include, but not be limited to, alarm initiating devices, alarm notification appliances, Network Fire Alarm Control Panels (FACP), Network Reporting Terminals (NRT), Network Liquid Crystal Display (NLCD), auxiliary control devices, annunciators, and wiring as shown on the drawings and specified herein.
- B. The fire alarm system shall comply with requirements of 1996 NFPA Standard 72 for Protected Premises Signaling Systems except as modified and supplemented by this Specification. The system shall be electrically supervised and monitor the integrity of all conductors.
- C. The fire alarm system shall be manufactured by an ISO 9001 certified company and meet the requirements of BS EN9001: ANSI/ASQC Q9001-1994. Provide proof of the certification, or demonstrate that the standards and experience required for certification are possessed, all to the satisfaction of the Engineer.
- D. The FACP and peripheral devices shall be manufactured 100% by a single manufacturer (or division thereof), in accordance with applicable U.S. industrial standards (i.e. NFPA, FM, etc.).
- E. The system and its components shall be Underwriters Laboratories, Inc. listed under the appropriate UL testing standard as listed herein for fire alarm applications and shall be in compliance with the UL listing.
- F. Each designated zone shall transmit separate and different alarm, supervisory and trouble signals to the Fire Command Center (FCC) and designated personnel in other buildings at the site via a multiplex communication
- G. The FACPs shall be active/interrogative-type systems where each transponder is repetitively scanned, causing a signal to be transmitted to the local fire alarm control panel node indicating that the transponder and its associated initiating device and notification appliance circuit wiring is functional. Loss of this signal at the local FACP shall result in a trouble indication on both the FACP display and at the network display, as specified hereinafter for the particular input.
- H. The system shall be arranged such that not less than 20 percent additional transponders may be inserted into any network communication loop.

- I. The installing company shall employ NICET (minimum Level II Fire Alarm Technology) technicians on site to guide the final check-out and to ensure the systems integrity.

1.07 DESIGN REQUIREMENTS

- A. A network intelligent reporting, microprocessor controlled fire detection alarm network shall be installed in accordance with the specifications and drawings.

- B. Basic Performance:

- 1. The connection between network control panels shall be Arcnet-based or other recognized network communication scheme and shall be wired in a Class A, Style 7 fashion.
- 2. Alarm and trouble signals from the FACP, NRT, and NLCD network nodes shall be digitally encoded by a listed electronic devices onto a NFPA Style 7 looped multiplex communication system.
- 3. Alarm, trouble and supervisory signals from all intelligent reporting devices shall be encoded onto NFPA Style 4 (Class B) Signaling Line Circuits (SLC).
- 4. Initiation Device Circuits (IDC) shall be wired Class A (NFPA Style D).
- 5. Notification Appliance Circuits (NAC) shall be wired Class A (NFPA Style Z).
- 6. Power for initiating devices and notification appliances must be from the main fire alarm control panel, the transponder to which they are connected or to a Field Charging Power Supply (FCPS).
- 7. A single ground or open on any system signaling line circuit, initiating device circuit, or notification appliance circuit shall not cause system malfunction, loss of operating power or the ability to report an alarm.
- 8. Alarm signals arriving at the main FACP shall not be lost following a power failure (or outage) until the alarm signal is processed and recorded.
- 9. Digitized electronic signals shall employ check digits or multiple polling.
- 10. Transponder devices are to consist of low current, solid-state integrated circuits, and shall be powered locally from a primary power and standby power source.

- C. Network - General

- 1. A node may be an intelligent Fire Alarm Control Panel (FACP), Network Reporting Terminal PC (NRT) or an Intelligent Network LCD Annunciator (INA). The network shall be capable of expansion to at least 103 nodes. Each network node address point shall be capable of processing a minimum of 1,980 analog addressable points. Each network node address shall be software assignable at each node. Systems which utilize a fixed network addressing scheme are not be suitable substitutes. There shall be NO limit to the types, mix, physical location or quantity of any node type below the overall limit of the



network node capacity. In addition, each network node shall also act as a signal repeater to reshape and regenerate the network signal.

D. Basic System Operation

1. When a fire alarm condition is detected and reported by one of the system initiating devices or appliances, the following functions shall immediately occur:
  - a. The FACP alarm LED on the FACP shall flash.
  - b. A local piezo-electric signal in the FACP control panel shall sound.
  - c. The 80-character LCD display on the local FACP node and on the network displays shall indicate all information associated with the fire alarm condition, including the type of alarm point, and its location within the protected premises. This information shall also be displayed on the network reporting terminal.
  - d. Printing and history storage equipment shall log the information associated with the fire alarm control panel condition, along with the time and date of occurrence.
  - e. All system output programs assigned via control-by-event interlock programming to be activated by the particular point in alarm shall be executed, and the associated system outputs (alarm notification appliances and/or relays) shall be activated on either local outputs or points located on other network nodes.
  
2. When a supervisory condition is detected and reported by one of the system initiating devices or appliances, the following functions shall immediately occur:
  - a. The FACP supervisory LED on the FACP shall flash.
  - b. A local piezo-electric signal in the FACP control panel shall sound.
  - c. The 80-character LCD display on the local FACP node and on the network displays shall indicate all information associated with the condition, including the type of point, and its location within the protected premises. This information shall also be displayed on the network reporting terminal.
  - d. Printing and history storage equipment shall log the information associated with the fire alarm control panel condition, along with the time and date of occurrence.
  - e. All system output programs assigned via control-by-event interlock programming to be activated by the particular point shall be executed, and the associated system outputs (alarm notification appliances and/or

relays) shall be activated on either local outputs or points located on other network nodes.

3. When a trouble condition is detected and reported by one of the system initiating devices or appliances, the following functions shall immediately occur:
  - a. The FACP trouble LED on the FACP shall flash.
  - b. A local piezo-electric signal in the FACP control panel shall sound.
  - c. The 80-character LCD display on the local FACP node and on the network displays shall indicate all information associated with the condition, including the type of point, and its location within the protected premises. This information shall also be displayed on the network reporting terminal.
  - d. Printing and history storage equipment shall log the information associated with the fire alarm control panel condition, along with the time and date of occurrence.
  - e. All system output programs assigned via control-by-event interlock programming to be activated by the particular point shall be executed, and the associated system outputs (alarm notification appliances and/or relays) shall be activated on either local outputs or points located on other network nodes.

E. Network Communication

1. The network architecture shall be based on a Local Area Network (LAN), a firmware package which utilizes a peer-to-peer, inherently regenerative communication format and protocol. The protocol shall be based on ARCNET or equivalent. The network shall use a deterministic token-passing method. Collision detection and recovery type protocols are not acceptable substitutes due to life safety requirements. In addition, there shall be no master, polling computer, central file computer, display controller or other central element (weak link) in the network which, on failure, may cause complete loss of network communications or cause major degradation of network capability. There shall be no cascading of CPUs or master-slave relationships at the network level to facilitate network communications. Failure of any node shall not cause failure or communication degradation of any other node or change the network communication protocol among surviving nodes located within distance limitations. Each node/panel shall communicate on the network at a baud rate of not less than 312 KBPS (kilobits per second).
2. Each network node address shall be capable of storing Cooperative-Control-By-Event (CCBE) equations. The CCBE shall be used to activate outputs on one network node from inputs on other network nodes. The

## GENERAL SPECIFICATION 13851 - FIRE DETECTION AND ALARM SYSTEM

---

CCBE equation shall support the following minimum Boolean operators: AND, OR and NOT.

### 1.08 SUBMITTALS

#### A. Shop Drawings:

1. Sufficient information, clearly presented, shall be included to determine compliance with drawings and specifications.
2. Include manufacturer's name(s), model numbers, ratings, power requirements, equipment layout, device arrangement, complete wiring point-to-point diagrams, and conduit layouts.
3. Show annunciator layout and main control panel module layout, configurations and terminations.

#### B. Manuals:

1. Submit simultaneously with the shop drawings, complete operating and maintenance manuals listing the manufacturer's name(s) including technical data sheets.
2. Wiring diagrams shall indicate internal wiring for each item of equipment and the interconnections between the items of equipment.
3. Provide a clear and concise description of operation which gives the information required to properly operate the equipment and system.

#### C. Software Modifications

1. Provide the services of a factory trained and authorized technician to perform all system software modifications, upgrades or changes. Response time of the technician to the site shall not exceed 4 hours.
2. Provide all hardware, software, programming tools and documentation necessary to modify the fire alarm network on site. Modification includes addition and deletion of devices, circuits, zones and changes to system operation and custom label changes for devices or zones. The system structure and software shall place no limit on the type or extent of software modifications on-site. Modification of software shall not require power-down of the system or loss of system fire protection while modifications are being made.

#### D. Certifications: Together with the shop drawing submittal, submit a certification from the major equipment manufacturer indicating that the proposed supervisor of installation and the proposed performer of contract maintenance is an authorized representative of the major equipment manufacturer and trained on network applications. Include names and addresses in the certification.

#### E. Post Contract Maintenance submittals as described in Article 1.08. Shop drawing submittals which do not include the estimate of post contract expansion cost will not be accepted.

## GENERAL SPECIFICATION 13851 - FIRE DETECTION AND ALARM SYSTEM

---

### 1.09 GUARANTY

- A. All work performed and all material and equipment furnished under this contract shall be free from defects and shall remain so for a period of at least one (1) year from the date of acceptance. The full cost of maintenance, labor and materials required to correct any defect during this one year period shall be included in the submittal bid.

### 1.10 POST CONTRACT MAINTENANCE

- A. Complete maintenance and repair service for the fire alarm system shall be available from a factory trained authorized representative of the manufacturer of the major equipment for a period of five (5) years after expiration of the guaranty.
- B. As part of the shop drawing submittal, include a quote for a maintenance contract to provide all maintenance, tests, and repairs described below. Include also a quote for unscheduled maintenance/repair, including hourly rates for technicians trained on this equipment and response travel costs for each year of the maintenance period. Submittals which do not identify all post contract maintenance costs will not be accepted. The rates and costs shall be valid for the period of five (5) years after expiration of the guaranty.
- C. Maintenance and testing shall be as required by the authorized factory representative. A preventive maintenance schedule shall be provided by the contractor describing the plan for preventive maintenance of all devices and subassemblies requiring regular maintenance. The schedule shall include:
  - 1. Systematic examination, adjustment and cleaning of all detectors, manual fire alarm stations, control panels, power supplies, relays, water flow switches and all accessories of the fire alarm system.
  - 2. Each circuit in the fire alarm network shall be tested semiannually.
  - 3. Each smoke detector shall be tested in accordance with the requirements of NFPA 72, Chapter 7.
- D. The authorized factory representative shall maintain facilities to provide parts and labor to expand the system specified, if so requested, for a period of five (5) years from the date of acceptance.
- E. As part of the shop drawing submittal a quotation for all parts and material, and all installation and test labor needed to increase the system capacity by ten percent (10%) shall be included. This quotation shall include but not be limited to: analog addressable smoke detectors, analog addressable heat detectors, addressable manual stations, addressable monitor modules, addressable control modules and notification appliances equal in number to one tenth of the number required to meet this Section (list actual quantity of each type).
- F. The shop drawing submittal quotation shall include installation, test labor, and labor to reprogram the system for this 10% expansion. If additional FACP hardware is required, include the material and labor necessary to install this hardware.

## **GENERAL SPECIFICATION 13851 - FIRE DETECTION AND ALARM SYSTEM**

---

- G. The shop drawing submittal quotation shall not include the cost of conduit or wire or the cost to install conduit or wire. The cost for labor to make final connections at the FACP and at each analog field device shall be included .

### 1.11 QUALITY ASSURANCE AND QUALIFICATIONS

- A. Manufacturer and Contractor shall be specialized in furnishing the complete fire alarm system for at least five years.
- B. Licensed Contractors - Only a person holding a license, or a special license in accordance with the provisions of the New York City Electrical Code, shall install, alter, or repair electrical wiring or apparatus for fire alarm systems in any building. Upon approval by the commissioner, a manufacturer's designated representative may alter or repair a specific fire alarm system.

### 1.12 SPARE PARTS

- A. The Contractor shall furnish and deliver to the City an additional ten (10) percent (minimum of 2) of the total smoke detectors, pull stations, horns with strobes and input/output modules, for replacement purposes as well as all the spare parts recommended by the manufacturer and approved by the Engineer, all of which shall be identical and interchangeable with similar parts furnished under this Section.
- B. The spare parts shall be packed in containers suitable for long term storage, bearing labels clearly designating the contents and the pieces of equipment for which they are intended.
- C. All spare parts shall be delivered neatly wrapped or boxed, indexed and tagged with complete information for use and reordering.

## PART 2 PRODUCTS

### 2.01 MANUFACTURERS

- A. The fire detection and alarm systems shall be as manufactured by:
  1. Notifier Fire Systems, Burgess Hill, United Kingdom.
  2. Edwards Systems Technology, Farmington, CT.
  3. Cerebus Pyrotronocs, Buffalo Grove, IL.
  4. Or approved equal.

### 2.02 EQUIPMENT AND MATERIAL, GENERAL

- A. All equipment and components shall be new, and the manufacturer's current model. The materials, appliances, equipment and devices shall be tested and listed by a nationally recognized approvals agency for use as part of a protected premises protective signaling (fire alarm) system. The authorized representative of the manufacturer of the major equipment, such as control panels, shall be responsible for the satisfactory installation of the complete system.

- B. All equipment and components shall be installed in strict compliance with each manufacturer's recommendations. Consult the manufacturer's installation manuals for all wiring diagrams, schematics, physical equipment sizes, etc. before beginning system installation. Refer to the riser/connection diagram for all specific system installation/termination/wiring data.
- C. All equipment shall be attached to walls and ceiling/floor assemblies and shall be held firmly in place (e.g., detectors shall not be supported solely by suspended ceilings). Fasteners and supports shall be adequate to support the required load.

## 2.03 CONDUIT AND WIRE

### A. Conduit:

1. Conduit shall be in accordance with the National Electrical Code (NEC), local and state requirements.
2. Where possible, all wiring shall be installed in conduit or raceway. Conduit fill shall not exceed 40 percent of interior cross sectional area where three or more cables are contained within a single conduit.
3. Cable must be separated from any open conductors of power, or Class 1 circuits, and shall not be placed in any conduit, junction box or raceway containing these conductors, per NEC Article 760-29.
4. Wiring for 24 volt control, alarm notification, emergency communication and similar power-limited auxiliary functions may be run in the same conduit as initiating and signaling line circuits. All circuits shall be provided with transient suppression devices and the system shall be designed to permit simultaneous operation of all circuits without interference or loss of signals.
5. Conduit shall not enter any FACP, or any other remotely mounted control panel equipment or backboxes, except where conduit entry is specified by the FACP manufacturer.
6. Conduit shall be 3/4 inch minimum.

### B. Wire:

1. All fire alarm system wiring must be new, unless specified herein.
2. Wiring shall be in accordance with local, state and national codes (e.g., NEC Article 760) and as recommended by the manufacturer of the fire alarm system. Number and size of conductors shall be as recommended by the fire alarm system manufacturer, but not less than 18 AWG for initiating device circuits and signaling line circuits, and 16 AWG for notification appliance circuits.
3. All wire and cable shall be listed and/or approved by a recognized testing agency for use with a protective signaling system.
4. Wire and cable not installed in conduit shall have a fire resistance rating suitable for the installation as indicated in NFPA 70 (e.g., FPLR).

5. Wiring used for the signaling line circuit (SLC) multiplex communication loop shall be twisted and shielded and installed in conduit unless specifically excepted by the fire alarm equipment manufacturer.
  6. All field wiring shall be completely supervised.
- C. Network Media:
1. General: The network shall be capable of communicating via wire or fiber optic medium. The network shall also support the use of both wire and fiber in the same network (hybrid network). A wire network shall include a fail-safe means of isolating the nodes in the unlikely event of complete power loss to a node. The fail safe design shall allow the network communications signal to bypass the failed node which allows the continuation of normal communications activity if specified wiring distances are maintained.
  2. Network Repeater: A network repeater shall be available to increase the twisted-pair distance capability in 3,000 ft. increments. As an option, a repeater shall be available for fiber optics which increases the wire distance in 10 dB increments. A mix (hybrid) fiber/wire network repeater shall also be supported. Systems which have distance limitations, and have no available means to regenerate signals are not suitable substitutes.
  3. Twisted Pair (wire) Communication: The dedicated twisted pair shall utilize 12 to 24 AWG wire and support distances of up to 3,000 ft between nodes.
- D. Terminal Boxes, Junction Boxes and Cabinets: All boxes and cabinets shall be UL listed for their intended purpose.
- E. Initiating circuits shall be arranged to serve like categories (manual, smoke, waterflow). Mixed category circuitry shall not be permitted except on signaling line circuits connected to intelligent reporting devices.
- F. The FACP(s) shall be connected to a separate dedicated branch circuit, maximum 20 amperes. This circuit shall be labeled at the main power distribution panel as FIRE ALARM. Fire alarm control panel primary power wiring shall be 12 AWG. The FACP cabinet shall be grounded securely to either a cold water pipe or grounding rod.

#### 2.04 FIRE ALARM CONTROL PANELS AND FIRE COMMAND CENTER

- A. Each network FACP shall contain a microprocessor-based central processing unit (CPU). The FACP shall communicate with and control the following types of equipment used to make up the system: intelligent detectors, addressable modules, transponders, local and remote operator terminals, printers, annunciators, and other system controlled devices.
- B. Each FACP on the network shall perform the following functions:
  1. Supervise and monitor all intelligent/addressable detectors and monitor modules connected to the system for normal, trouble and alarm conditions.

2. Supervise all initiating signaling and notification circuits throughout the facility by way of connection to transponders.
  3. Detect the activation of any initiating device and the location of the alarm condition. Operate all notification appliances and auxiliary devices as programmed.
  4. Visually and audibly annunciate any trouble, supervisory or alarm, condition on operator's terminal, panel display, and annunciators.
- C. General FACP Operation:
1. Each FACP node shall include a full featured operator interface control and annunciation panel which shall include a backlit Liquid Crystal Display (LCD), individual, color coded system status LEDs, and an alpha-numeric keypad for field programming and control of the node.
  2. All programming or editing of the existing programming in the system shall be achieved without special equipment or interrupting the alarm monitoring functions of the fire alarm control panel.
  3. Each FACP node shall be capable of providing the following features:
    - a. Block Acknowledge for Trouble Conditions
    - b. Rate Charger Control
    - c. Control-By-Time (Delay, Pulse, time of day, etc.)
    - d. Automatic Day/Night Sensitivity Adjust (high/low)
    - e. Device Blink Control (turn of detector LED strobe)
    - f. Environmental Drift Compensation (selectable ON or OFF)
    - g. Smoke Detector Pre-alarm Indication at Control Panel
    - h. NFPA 72 Smoke Detector Sensitivity Test
    - i. System Status Reports
    - j. Alarm Verification, by device, with tally
    - k. Multiple Printer Interface
    - l. Multiple CRT Display Interface
    - m. Non-Fire Alarm Module Reporting
    - n. Automatic NFPA 72 Detector Test
    - o. Programmable Trouble Reminder
    - p. Upload/Download System Database to PC Computer
    - q. One-Man Walk Test



- r. Smoke Detector Maintenance Alert
- s. Security Monitor Points
- t. Alpha-numeric Pager Interface
- u. On-line or Off-line programming

D. FACP Central Processing Unit (CPU):

1. Each FACP network node shall include a central processing unit. The CPU shall communicate with, monitor, and control all other modules within the control panel. Removal, disconnection or failure of any control panel module shall be detected and reported to the system display by the CPU.
2. Each CPU shall contain and execute all control-by-event interlock for specific local and network action to be taken if an alarm condition is detected by the system. Control-by-event programs shall be held in non-volatile programmable memory, and shall not be lost even if system primary and secondary power failure occurs.
3. The central processing unit shall also provide a real-time clock for time annotation of all system displays. The time-of-day and date shall not be lost if system primary and secondary power supplies fail.

E. Loop Interface Board (LIB):

1. Loop interface boards shall be provided to monitor and control each of the Signaling Line Circuit (SLC) loops in the network node. The loop interface board shall contain its own microprocessor and shall be capable of operating in local mode in the case of a failure in the main CPU of the control panel. In local mode, the loop interface board shall detect alarms and activate output devices on its own SLC loop.
2. The LIB shall not require any jumper cuts or address switch settings to initialize SLC Loop operations.
3. The loop interface board shall provide power to, and communicate with, all of the intelligent detectors and addressable modules connected to its SLC Loop over a single pair of wires. This SLC Loop shall be capable of operation as NFPA Style 4, Style 6, or Style 7.
4. The LIB shall be able to drive two Style 4 SLC loops, each up to 10,000 feet in length, for an effective loop span of 20,000 feet.
5. The loop interface board shall receive analog information from all intelligent detectors and shall process this information to determine whether normal, alarm, or trouble conditions exist for that particular detector. The loop interface board software shall include software to automatically adjust and compensate for dust accumulation to maintain detector performance as it is affected by environmental factors. The analog information may also be used for automatic

detector testing and for the automatic determination of detector maintenance requirements.

6. The LIB shall communicate with each intelligent addressable detector and addressable module on its SLC loop and verify proper device function and status. Communication with up to 198 intelligent devices shall be performed every 6 seconds or less.

F. Serial Interface Board (SIB):

1. The serial Interface board shall provide the EIA-232 interface between local FACP nodes and UL listed Electronic Data Processing (EDP) peripherals.
2. The SIB shall allow the use of multiple printers, CRT monitors, and other peripherals connected to the EIA-232 ports.
3. The serial interface board shall provide one EIA-485 port for the serial connection of optional annunciators and control subsystem components.
4. The SIB shall include LEDs which indicate that it is in regular communication with the annunciators and other EIA-485 connected peripheral devices.
5. All EIA-232 circuits shall be optically isolated and power limited.

G. Enclosures:

1. Control panels shall be housed in UL-listed cabinets suitable for surface or semi-flush mounting. Cabinets shall be corrosion protected, given a rust-resistant prime coat, and the manufacturer's standard finish.
2. The back box and door shall be constructed of 0.060 steel with provisions for electrical conduit connections into the sides and top.
3. The door shall provide a key lock and include a transparent opening for viewing all indicators. For convenience, the door shall have the ability to be hinged on either the right or left-hand side.
4. The control unit shall be modular in structure for ease of installation, maintenance, and future expansion.

H. FACP nodes shall be designed so that it permits continued local operation of remote transponders under both normal and abnormal network communication loop conditions. This shall be obtained by having transponders operate as local control panels upon loss of network communication.

I. FACP nodes shall be modular in construction to allow ease of servicing. Each CPU and transponder shall be capable of being programmed on site without requiring the use of any external programming equipment. Systems which require use of external programmers or change of EPROMs are not acceptable.

J. The CPU and associated equipment are to be protected so that they will not be affected by voltage surges or line transients including RFI and EMI.

- K. Each transponder and peripheral device connected to the FACP node CPU shall be continuously scanned for proper operation. Data transmissions between network nodes, FACP CPUs, transponders, and peripheral devices shall be reliable and error free. The transmission scheme used shall employ dual transmission or other equivalent error checking techniques. Failure of any transponder or peripheral device to respond to an interrogation shall be annunciated as a trouble condition.
- L. FACP Power Supplies:
1. Main power supplies shall operate on 120/240 VAC, 50/60Hz, and shall provide all necessary power for the FACP.
  2. Each main supply shall provide 3.0 amps of usable notification appliance power, using a switching 24 VDC regulator.
  3. The main power supply shall be expandable for additional notification appliance power in 3.0 ampere steps.
  4. Each main power supply shall provide a battery charger for 24 hours of standby using dual-rate charging techniques for fast battery recharge. It shall charge 60 Amp hour batteries within a 48-hour period.
  5. The supply shall provide a very low frequency sweep earth detect circuit, capable of detecting earth faults.
  6. It shall provide meters to indicate battery voltage and charging current.
  7. The main power supply shall be power-limited per 1995 UL864 requirements.
- M. Field Charging Power Supply: The FCPS is a device designed for use as either a remote 24 volt power supply or used to power Notification Appliances.
1. The FCPS shall offer up to 6.0 amps (4.0 amps continuous) of regulated 24 volt power. It shall include an integral charger designed to charge 7.0 amp hour batteries and to support 60 hour standby.
  2. The Field Charging Power Supply shall have two input triggers. The input trigger shall be a Notification Appliance Circuit (from the fire alarm control panel) or a relay. Four outputs (two Style Y or Z and two style Y) shall be available for connection to the Notification devices.
  3. The FCPS shall include an attractive surface mount backbox.
  4. The Field Charging Power Supply shall include the ability to delay the AC fail delay per 1993 NFPA requirements.
  5. The FCPS include power limited circuitry, per 1995 UL standards.
- N. System Circuit Supervision:
1. Each FACP node shall supervise all circuits to intelligent devices, transponders, annunciators and peripheral equipment and annunciate loss of communications with these devices. The FACP CPU shall continuously scan the above devices

- for proper system operation and upon loss of response from a device shall sound an audible trouble, indicate which device or devices are not responding and print the information on the printer.
2. Sprinkler system valves, standpipe control valves, PIV, and main gate valves shall be supervised for off-normal position.
  3. Transponders that lose communication with a FACP CPU shall sound an audible trouble and light an LED indicating loss of communications.
  4. Transponder Circuit Supervision: Transponders shall be designed such that they continuously scan all of their initiating and notification circuits. With normal communications between the FACP and the transponders, the transponders shall transmit initiating and notification circuit trouble conditions to the FACP for audible annunciation and printout. With or without communication with the FACP node, the transponders shall supervise their circuits and annunciate any initiating circuit and notification circuit failures on LEDs located in the transponder.
- O. Field Wiring Terminal Blocks: For ease of service, all wiring terminal blocks shall be the plug-in type and have sufficient capacity for 18 to 12 AWG wire. Fixed terminal blocks are not acceptable.
- P. Operators Terminal: Provide the following functions in addition to any other functions required for the system.
1. Acknowledge (ACK/STEP) Switch:
    - a. Activation of the control panel Acknowledge switch in response to a single new Alarm and/or trouble condition shall silence the local panel piezo electric signal and change the system alarm or trouble LED from flashing mode to steady-ON mode. If additional new alarm or trouble conditions exist or are detected and reported in the system, depression of this switch shall advance the 80-character LCD display to the next alarm or trouble condition.
    - b. Depressing the acknowledge switch shall also silence all remote annunciator piezo sounders.
  2. Signal Silence Switch: Activation of the signal silence switch shall cause all programmed alarm notification appliances and relays to return to the normal condition after an alarm activation. The selection of notification circuits and relays which are silenceable by this switch shall be fully field programmable within the confines of all applicable standards.
  3. System Reset Switch: Activation of the system reset switch shall cause all local electronically-latched initiating devices, software zones, output devices and circuits, to return to their normal condition. If an alarm condition(s) still exists, or if they reoccur in the system after system reset switch activation, the system shall then resound the alarm conditions.

4. System Test Switch: Activation of the system test switch shall initiate an automatic test of all intelligent/addressable detectors in the local system. The system test shall activate the electronics in each intelligent sensor, simulating an alarm condition and causing the transmission of the alarm condition from that sensor to the fire alarm control panel. The fire alarm control panel shall interpret the data from each sensor installed in the system. A report summarizing the results of this test shall be displayed automatically on the system LCD and on any CRTs or printers in the system.
  5. Lamp Test Switch: Activation of the lamp test switch shall sequentially turn on all LED indicators, system liquid crystal display and local piezo signal, and then automatically return the fire alarm control panel to the previous condition.
- Q. Video Display Terminal (VDT):
1. The video display terminal shall provide a visual display and an audible alert of all changes in status of the system and shall annotate such displays with the current time-of-day and date.
  2. The VDT shall be enclosed in a cabinet suitable for placement on a desk top or table.
  3. A detachable keyboard shall be provided with the VDT which may be used for programming, testing, and control of the system. Individual keys shall be provided on the keyboard for the ACKNOWLEDGE, RESET, LAMP TEST, SYSTEM TEST, and SIGNAL SILENCE functions of the FACP node.
  4. The video display terminal shall include a count of all alarms and troubles in the system as well as a count of all alarms and troubles requiring acknowledgment. These counts shall be continuously displayed during all FACP operations.
- R. Printer:
1. Printers shall be UL 864 listed and shall be an automatic type with code, time, date, location, category, and condition.
  2. The printer shall provide hard-copy printout of all changes in status of the system and shall time-stamp such printouts with the current time-of-day and date. The printer shall be standard carriage with 80-characters per line and shall use standard pin-feed paper. The printer shall be enclosed in a separate cabinet suitable for placement on a desk top or table. The printer shall communicate with the control panel using an interface complying with Electrical Industries Association (EIA) standard EIA-232D. Power to the printer shall be 120 VAC 60 Hz.
  3. Thermal printers are not acceptable.
- S. Transponders:

1. Transponders shall be listed under UL category UOJZ as an independent, local fire alarm control unit as well as being listed as a critical component in a multiplex fire alarm system. Transponders shall be located where shown on the plans.
2. The transponder shall serve as the interface between initiating fire devices, controlled signaling devices, and each FACP node. The supervised multiplex communication port shall be an integral part of the transponder.
3. Each transponder shall be powered from a local power supply, and shall provide all power necessary for its own operation, including standby power.
4. Transponders shall communicate with, and be controlled by, the host FACP via a 2-wire communications loop. The communications loop shall operate as an NFPA Style 4, Style 6 or Style 7 loop.
5. Transponders shall be used to house amplifiers, batteries and power supplies to allow true distributed processing and amplification.
6. Each transponder shall have the following indicators and operator controls:
  - a. Alarm Acknowledge/Reset Switch
  - b. Power LED
  - c. System alarm LED
  - d. System trouble LED
  - e. Local piezoelectric signal
  - f. Red alarm per initiating device circuit
  - g. Green on/off LED per notification appliance circuit or relay
7. Each transponder will be capable of expansion of up to 24 field circuits of the following types in any mix:
  - a. Initiating Device Circuits (IDC): IDCs may be added to the transponder in groups of 8 Style B (Class B), or 4 Style D (Class A) circuits. Each circuit shall be capable of monitoring up to 30 compatible 2-wire smoke detectors, and/or any number of contact type initiating devices.
  - b. Auxiliary Control Relay Outputs: Auxiliary relay outputs may be added to the transponder in groups of eight individually controlled single Form-C circuits, or four dual Form-C circuits. All Auxiliary circuits shall be rated 2 A. @ 30 VDC.

**T. Field Programming:**

1. The system shall be programmable, configurable and expandable in the field without the need for special tools or electronic equipment and shall not require field replacement of electronic integrated circuits.

2. All local FACP node programming shall be accomplished through the FACP keyboard or through the video display terminal.
3. All field defined programs shall be stored in non-volatile memory.
4. The programming function shall be enabled with a password that may be defined specifically for the system when it is installed. Two levels of password protection shall be provided in addition to a key-lock cabinet. One level is used for status level changes such as zone disable or manual on/off commands. A second (higher-level) is used for actual change of program information.

U. Specific System Operations:

1. Smoke Detector Sensitivity Adjust: Means shall be provided for adjusting the sensitivity of any or all analog intelligent detectors in the FACP node from each system keypad or from the keyboard of the video terminal. Sensitivity range shall be within allowed UL limits.
2. Alarm Verification: Each of the intelligent addressable detectors in the system may be independently selected and enabled for alarm verification. Each FACP shall keep a count of the number of times each detector has entered the verification cycle. These counters may be displayed and reset by the proper operator commands.
3. System Point Operations:
  - a. All devices in the FACP node may be enabled or disabled through the local keypad or video terminal.
  - b. Any FACP node output point may be turned on or off from the local system keypad or the video terminal.
4. Point Read: The FACP node shall be able to display the following point status diagnostic functions without the need for peripheral equipment. Each point will be annunciated for the parameters listed:
  - a. Device Status
  - b. Device Type
  - c. Custom Device Label
  - d. Software Zone Label
  - e. Device Zone Assignments
  - f. Detector Analog Value
  - g. All Program Parameters
5. System Status Reports: Upon command from a password-authorized operator of the system, a status report will be generated, and printed, listing all local FACP system status.

6. System History Recording and Reporting: Each FACP node shall contain a history buffer that shall be capable of storing a minimum of 400 system events. Each local activation will be stored and time and date stamped with the actual time of the activation, until an operator requests that the contents be either displayed or printed. The contents of the history buffer may be manually reviewed, one event at a time, and the actual number of activations may also be displayed and or printed.
7. The history buffer shall use non-volatile memory. Systems which use volatile memory for history storage are not acceptable.
8. Automatic Detector Maintenance Alert: Each FACP node shall automatically interrogate each intelligent system detector and shall analyze the detector responses over a period of time. If any intelligent detector in the system responds with a reading that is below or above normal limits, then the system will enter the trouble mode, and the particular intelligent detector will be annunciated on the system display, network display and printed on the optional system printer. This feature shall in no way inhibit the receipt of alarm conditions in the system, nor shall it require any special hardware, special tools or computer expertise to perform.

## 2.05 NETWORK MONITORING DEVICES

### A. Intelligent Network Annunciator:

1. An intelligent network annunciator shall be provided to display all system intelligent points. The INA shall be capable of displaying all information for all 200,000 possible points on the network. Network display devices which are only capable of displaying a subset of network points shall not be suitable substitutes.
2. The INA shall include a minimum of 80 characters, backlit by a long life solid state LCD display. The network display shall mount in any of the network node fire alarm control panels. Optionally, the network display may mount in an attractive backbox designed for this use, or may mount in an industry standard 19-inch (482.6 mm) rack. The network shall support over 103 network display annunciators (not to exceed total node capacity) and shall connect to the network over either a wire or fiber interface.
3. The intelligent network annunciator shall have a history buffer capable of storing a minimum of 400 events in nonvolatile memory.
4. The INA shall include two optically isolated, 2400 baud, industry standard EIA-232 ports for UL864 listed printers and CRTs. These peripheral devices shall print or display network activity.
5. The intelligent network annunciator shall include five control switches for system wide control of signal Silence, Reset, Activate Signals (Drill), and Lamp



Test (local). A means by which the controls switches are "locked out", such as a key, shall be available.

6. The INA shall include long life LEDs to display Power, Fire Alarm, Security Alarm, System Trouble, Supervisory, Signals Silenced, and CPU Failure.
7. The intelligent network annunciator shall include two software assignable passwords, up to five digits in length.
8. For time keeping purposes the INA shall include a time of day clock.
9. The intelligent network annunciator shall include the ability to interface to Motorola's Alert Central Paging system. With this option the INA shall have the ability to send every network event to the Alert Central. The Alert Central can then send the INA's complete 80 character message to select pocket pagers.
10. Each INA shall support up to 32 additional 80 character remote display annunciators for displaying network activity. These "Terminal Mode" displays will mimic the activity appearing on the corresponding INA.

2.06 SYSTEM COMPONENTS - CONVENTIONAL

A. Programmable Electronic Sounders:

1. Electronic sounders shall operate on 24 VDC nominal.
2. Electronic sounders shall be field programmable without the use of special tools, to provide slow whoop, continuous, or interrupted tones with an output sound level of at least 90 dBA measured at 10 feet (3 meters) from the device.
3. Shall be flush or surface mounted as show on plans.

B. Strobe lights shall meet the requirements of the ADA, UL Standard 1971 and shall meet the following criteria:

1. The maximum pulse duration shall be 2/10 of one second.
2. Strobe intensity shall meet the requirements of UL 1971.
3. The flash rate shall meet the requirements of UL 1971.

C. Duct Smoke Detectors:

1. Duct smoke detectors shall be a 24 VDC type with visual alarm and power indicators, and a reset switch. Each detector shall be installed upon the composite supply/return air ducts(s), with properly sized air sampling tubes.

D. Sprinkler and Standpipe Valve Supervisory Switches:

1. Each sprinkler system water supply control valve riser, zone control valve, and standpipe system riser control valve shall be equipped with a supervisory switch. Standpipe hose valves, and test and drain valves shall not be equipped with supervisory switches.

2. PIV (post indicator valve) or main gate valves shall be equipped with a supervisory switch.
3. The switch shall be mounted so as not to interfere with the normal operation of the valve and adjusted to operate within two revolutions toward the closed position of the valve control, or when the stem has moved no more than one-fifth of the distance from its normal position.
4. The supervisory switch shall be contained in a weatherproof aluminum housing, which shall provide a 3/4 inch (19 mm) conduit entrance and incorporate the necessary facilities for attachment to the valves.
5. The switch housing shall be finished in red baked enamel.
6. The entire installed assembly shall be tamper proof and arranged to cause a switch operation if the housing cover is removed, or if the unit is removed from its mounting.
7. Valve supervisory switches shall be provided and connected under this section and installed by other contractors.

2.07 SYSTEM COMPONENTS, INTELLIGENT

A. Addressable Devices - General:

1. Addressable devices shall use simple to install and maintain decade (numbered 0 to 9) type address switches.
2. Addressable devices which use a binary address setting method, such as a Dip switch, are not an allowable substitute.
3. Detectors shall be intelligent (analog) and addressable, and shall connect with two wires to the FACP signaling line circuit.
4. Addressable smoke and thermal detectors shall provide dual alarm and power/polling LEDs. Both LEDs shall flash under normal conditions, indicating that the detector is operational and in regular communication with the control panel, and both LEDs shall be placed into steady illumination by the control panel, indicating that an alarm condition has been detected. If required, the LED flash shall have the ability to be removed from the system program. An output connection shall also be provided in the base to connect an external remote alarm LED.
5. The fire alarm control panel shall permit detector sensitivity adjustment through field programming. Sensitivity shall be automatically adjusted by the panel on a time-of-day basis.
6. Using software in the FACP, detectors shall automatically compensate for dust accumulation and other slow environmental changes that may affect their performance. The detectors shall be listed by UL as meeting the calibrated sensitivity test requirements of NFPA Standard 72, Chapter 7.

7. The detectors shall be ceiling-mount and shall include a separate twist-lock base with tamper proof feature. Base shall include a sounder base with a built-in (local) sounder rated at 85 dBA minimum, a relay base and an isolator base designed for Class A applications.
8. The detectors shall provide a test means whereby they will simulate an alarm condition and report that condition to the control panel. Such a test may be initiated at the detector itself (by activating a magnetic switch) or initiated remotely on command from the control panel.
9. Detectors shall also store an internal identifying type code that the control panel shall use to identify the type of device (ION, PHOTO, THERMAL).
10. Detectors will operate in an analog fashion, where the detector simply measures its designed environment variable and transmits an analog value to the FACP based on real-time measured values. The FACP software, not the detector, shall make the alarm/normal decision, thereby allowing the sensitivity of each detector to be set in the FACP program and allowing the system operator to view the current analog value of each detector.
11. Addressable devices shall provide address-setting means using decimal switches and shall also store an internal identifying code that the control panel shall use to identify the type of device. LED(s) shall be provided that shall flash under normal conditions, indicating that the device is operational and is in regular communication with the control panel.
12. A magnetic test switch shall be provided to test detectors and modules. Detectors shall report an indication of an analog value reaching 100% of the alarm threshold.

**B. Addressable Pull Box (manual station):**

1. Addressable pull boxes shall, on command from the control panel, send data to the panel representing the state of the manual switch and the addressable communication module status. They shall use a key operated test-reset lock, and shall be designed so that after actual emergency operation, they cannot be restored to normal use except by the use of a key.
2. All operated stations shall have a positive, visual indication of operation and utilize a key type reset.
3. Manual stations shall be constructed of Lexan with clearly visible operating instructions provided on the cover. The word FIRE shall appear on the front of the stations in raised letters, 1.75 inches (44 mm) or larger.

**C. Intelligent Multi-Detector:**

1. The intelligent multi-detector shall be an addressable device which is designed to monitor photoelectric, ionization, and thermal technologies in a single sensing device. This detector shall utilize advanced electronics which react to

smaller products of combustion found in fast flaming fires (ionization), slow smoldering fires (photoelectric), and heat (thermal) all within a single sensing device.

2. The multi-detector shall include two bicolor LEDs which flash green in normal operation and turn on steady red in alarm.

D. Intelligent Thermal Detectors:

1. Thermal detectors shall be intelligent addressable devices rated at 135 degrees Fahrenheit (58 degrees Celsius) and have a rate-of-rise element rated at 15 degrees F (9.4 degrees C) per minute. It shall connect via two wires to the fire alarm control panel signaling line circuit.

E. Hostile-Area Smoke Detector:

1. The detector shall be designed to provide early warning smoke detection in environments where traditional smoke detectors are not practical.
2. The detector shall have a filter system to remove particles down to 25 microns.
3. This filter system shall remove unwanted airborne particles and water mist. This shall allow the detector to operate in environments where traditional smoke detectors would have nuisance alarms.
4. The filter system shall consist of 2 filters one of which is field replaceable.
5. The filter system shall have an intake fan to draw air and smoke through the filters into the sensing chamber.
6. The filter system shall be supervised so that if the filter is clogged or the fan fails the control panel reports trouble.
7. The filter system shall be powered from 24 VDC separate from the SLC communications.
8. The detector shall utilize a photoelectric sensing chamber.

F. Addressable Dry Contact Monitor Module:

1. Addressable monitor modules shall be provided to connect one supervised IDC zone of conventional alarm initiating devices (any N.O. dry contact device) to one of the fire alarm control panel SLCs.
2. The monitor module shall mount in a 4-inch square, 2-1/8 inch deep electrical box.
3. The IDC zone shall be suitable for Style D or Style B operation. An LED shall be provided that shall flash under normal conditions, indicating that the monitor module is operational and in regular communication with the control panel.

4. For difficult to reach areas, the monitor module shall be available in a miniature package and shall be no larger than 2-3/4 inch x 1-1/4 inch x 1/2 inch. This version need not include Style D or an LED.

G. Addressable Control Module:

1. Addressable control modules shall be provided to supervise and control the operation of one conventional NACs of compatible, 24 VDC powered, polarized audio/visual notification appliances. For fan shutdown and other auxiliary control functions, the control module may be set to operate as a dry contact relay.
2. The control module shall mount in a standard 4-inch square, 2-1/8 inch deep electrical box, or to a surface mounted backbox.
3. The control module NAC may be wired for Style Z or Style Y (Class A/B) with up to 1 amp of inductive A/V signal, or 2 amps of resistive A/V signal operation, or as a dry contact (Form-C) relay. The relay coil shall be magnetically latched to reduce wiring connection requirements, and to insure that 100% of all auxiliary relay or NACs may be energized at the same time on the same pair of wires.
4. Audio/visual power shall be provided by a separate supervised power circuit from the main fire alarm control panel or from a supervised, UL listed remote power supply.
5. The control module shall be suitable for pilot duty applications and rated for a minimum of 0.6 amps at 30 VDC.

H. Isolator Module:

1. Isolator modules shall be provided to automatically isolate wire-to-wire short circuits on an SLC Class A or Class B branch. The isolator module shall limit the number of modules or detectors that may be rendered inoperative by a short circuit fault on the SLC loop segment or branch. At least one isolator module shall be provided for each floor or protected zone of the building.
2. If a wire-to-wire short occurs, the isolator module shall automatically open-circuit (disconnect) the SLC. When the short circuit condition is corrected, the isolator module shall automatically reconnect the isolated section.
3. The isolator module shall not require any address-setting, and its operations shall be totally automatic. It shall not be necessary to replace or reset an isolator module after its normal operation.
4. The isolator module shall mount in a standard 4-inch deep electrical box or in a surface mounted backbox. It shall provide a single LED that shall flash to indicate that the isolator is operational and shall illuminate steadily to indicate that a short circuit condition has been detected and isolated.

I. Serially Connected Annunciator Requirements:

1. The annunciator shall communicate to the fire alarm control node or INA via an EIA 485 (multi-drop) two wire communications loop. The FACP node shall support two 6,000 ft. EIA-485 wire runs. Up to 32 annunciators, each configured up to 64 points, may be connected to connections, for a system capacity of 2,048 points of annunciation.
2. An EIA-485 repeater shall be available to extend the EIA-485 wire distance in 3,000 ft. increments. An optional (UL 864 listed) version shall allow the EIA-485 circuit to be transmitted over Fiber optics.
3. Annunciator switches may be programmed for system control such as, global acknowledge, global signal silence, global system reset, and on/off control of any control point in the system.
4. An optional module shall be available utilizing annunciator points to drive EIA-485 driven relays. This shall extend the system point capacity by 2,048 remote contacts.

J. LCD Alphanumeric Display Annunciator:

1. The alphanumeric display annunciator shall be a supervised, back-lit LCD display containing a minimum of eighty (80) characters for alarm annunciation in clear English text.
2. The LCD annunciator shall display all alarm and trouble conditions from either the network node or complete network, via the INA.
3. Up to 32 LCD annunciators may be connected to a specific (terminal mode) EIA 485 interface. LCD annunciators shall not reduce the annunciation capacity of the system. Each LCD shall include vital system wide functions such as, system acknowledge, silence and reset.
4. LCD display annunciators shall mimic the local control panel 80-character display or network annunciator and shall not require special programming.

2.08 BATTERIES AND EXTERNAL CHARGER

A. Battery:

1. Batteries shall be 12 volt, Gell-Cell type.
2. The battery shall have sufficient capacity to power the fire alarm system for not less than 24 hours plus 5 minutes of alarm upon a normal AC power failure.
3. The batteries are to be completely maintenance free. No liquids are required. Fluid level checks for refilling, spills and leakage shall not be required.

2.09 PAINTING

- A. Painting shall conform to the requirements of General Specification 09900 - Painting. Finish color of equipment shall be red.

## GENERAL SPECIFICATION 13851 - FIRE DETECTION AND ALARM SYSTEM

---

### 2.10 ELECTRICAL WORK

- A. All wiring and conduit connections necessary to make the Fire Alarm System operational shall be furnished and installed under this Contract.

### PART 3 EXECUTION

#### 3.01 INSTALLATION

- A. Installation shall be in accordance with the NEC, NFPA 72, local and state codes, as shown on the Contract Drawings, and as recommended by the major equipment manufacturer.
- B. All conduit, junction boxes, conduit supports and hangers shall be concealed in finished areas and may be exposed in unfinished areas. Smoke detectors shall not be installed prior to the system programming and test period. If construction is ongoing during this period, measures shall be taken to protect smoke detectors from contamination and physical damage.
- C. All fire detection and alarm system devices, control panels and remote annunciators shall be flush mounted when located in finished areas and may be surface mounted when located in unfinished areas.
- D. Manual Pull Stations shall be suitable for surface mounting or semiflush mounting as shown on the plans, and shall be installed not less than 42 inches, nor more than 48 inches above the finished floor.

#### 3.02 TYPICAL OPERATION

- A. Actuation of any manual station, smoke detector, heat detector or waterflow switch shall cause the following operations to occur unless otherwise specified:
  - 1. Actuate strobe units until the panel is reset.
  - 2. Light the associated indicators corresponding to active speaker circuits.
  - 3. Where required, return all elevators to the primary or alternate floor of egress.
  - 4. A smoke detector in any elevator lobby shall, in addition to the above functions, return all elevators to the primary or alternate floor of egress.
  - 5. Smoke detectors in the elevator machine room or top of hoistway shall return all elevators in to the primary or alternate floor. Smoke detectors or heat detectors installed to shut down elevator power shall do so in accordance with ANSI A17.1 requirements and be coordinated with the electrical contractor.
  - 6. Duct type smoke detectors shall, in addition to the above functions, shut down the ventilation system or close associated control dampers as appropriate.
  - 7. Activation of any sprinkler system low pressure switch, on valve tamper switch, shall cause a system supervisory alarm indication.

3.03 TESTING

- A. The service of a competent, factory-trained engineer or technician authorized by the manufacturer of the fire alarm equipment shall be provided to technically supervise and participate during all of the adjustments and tests for the system.
- B. Before energizing the cables and wires, check for correct connections and test for short circuits, ground faults, continuity, and insulation.
- C. Close each sprinkler system flow valve and verify proper supervisory alarm at the FACP.
- D. Verify activation of all flow switches.
- E. Open initiating device circuits and verify that the trouble signal actuates.
- F. Open signaling line circuits and verify that the trouble signal actuates.
- G. Open and short notification appliance circuits and verify that trouble signal actuates.
- H. Open and short (wire only) network communications and verify that trouble signals are received at network annunciators or reporting terminals.
- I. Ground initiating device circuits and verify response of trouble signals.
- J. Ground signaling line circuits and verify response of trouble signals.
- K. Ground notification appliance circuits and verify response of trouble signals.
- L. Check alert tone and prerecorded voice message to all alarm notification devices.
- M. Check installation, supervision, and operation of all intelligent smoke detectors using walk test.
- N. Each of the alarm conditions that the system is required to detect should be introduced on the system. Verify the proper receipt and the proper processing of the signal at the FACP and the correct activation of the control points.
- O. When the system is equipped with optional features, the manufacturer's manual should be consulted to determine the proper testing procedures. This is intended to address such items as verifying controls performed by individually addressed or grouped devices, sensitivity monitoring, verification functionality and similar.

3.04 FINAL INSPECTION

- A. At the final inspection, a factory-trained representative of the manufacturer of the major equipment shall demonstrate that the system functions properly in every respect.

3.05 INSTRUCTION

- A. Instruction shall be required for operating the system. Hands-on demonstrations of the operation of all system components and the entire system including program changes and functions shall be provided.



## **GENERAL SPECIFICATION 13851 - FIRE DETECTION AND ALARM SYSTEM**

---

- B. The Contractor and/or the systems manufacturer's representatives shall provide a typewritten "Sequence of Operation."

END OF SECTION

**GENERAL SPECIFICATION 13851 - FIRE DETECTION AND ALARM SYSTEM**

NO TEXT ON THIS PAGE

**SECTION 15053  
Aluminum, Copper and Brass Pipe**

**PART 1 GENERAL**

**1.01 SECTION INCLUDES**

- A. The Contractor shall provide aluminum, copper and brass pipe and fittings as indicated. This section includes all aluminum, copper and brass pipe and fittings, including all insulation, painting and related work as shown on the Contract Drawings, specified herein, or required for a complete installation.
- B. The following index of this Section is included for convenience.

<u>Article</u>	<u>Title</u>	<u>Page</u>
		15053-
PART 1	GENERAL.....	1
1.01	Section Includes.....	1
1.02	Payment.....	1
1.03	Related Sections.....	2
1.04	References.....	2
1.05	Design Requirements.....	3
1.06	Submittals.....	3
1.07	Delivery, Storage And Handling.....	4
PART 2	PRODUCTS.....	4
2.01	Manufacturers.....	4
2.02	Materials.....	5
PART 3	EXECUTION.....	11
3.01	Installation.....	11
3.02	Cleaning And Testing.....	13
3.03	Painting And Insulation.....	13
3.04	Disinfection.....	13

**1.02 PAYMENT**

- A. There shall be no separate payment for the work of this Section; all costs shall be included in the Lump Sum price bid for the Contract, unless otherwise specified.
- B. No direct payment will be made for painting, insulation and testing pipelines or for gaskets, bolts, nuts and other appurtenances and material required to erect the lines; the costs thereof shall be included in the prices bid for the pipe.

## **GENERAL SPECIFICATION 15053 - ALUMINUM, COPPER & BRASS PIPE**

---

### 1.03 RELATED SECTIONS

- A. Section 02505 - Leakage Tests
- B. Section 09900 - Painting
- C. Section 15051 - Ductile and Cast Iron Pipe
- D. Section 15052 - Steel and Stainless Steel Pipe
- E. Section 15056 - Pipe Couplings
- F. Section 15060 - Hangers and Supports
- G. Section 15076 - Piping and Equipment Identification
- H. Section 15081 - Piping Insulation
- I. Section 15141 - Disinfection
- J. Section 15810 - Ductwork and Duct Accessories

### 1.04 REFERENCES

- A. American Society for Testing and Materials (ASTM):
  - 1. B26/B26M Standard Specification for Aluminum-Alloy Sand Castings
  - 2. B32 Standard Specification for Solder Metal
  - 3. B42 Standard Specification for Seamless Copper Pipe, Standard Sizes
  - 4. B43 Standard Specification for Seamless Red Brass Pipe, Standard Sizes
  - 5. B61 Standard Specification for Steam or Valve Bronze Castings
  - 6. B62 Standard Specification for Composition Bronze or Ounce Metal Castings
  - 7. B88 Standard Specification for Seamless Copper Water Tube
  - 8. B108/108M Standard Specification for Aluminum-Alloy Permanent Mold Castings
  - 9. B210 Standard Specification for Aluminum and Aluminum-Alloy Drawn Seamless Tubes
  - 10. B241/B241M Standard Specification for Aluminum and Aluminum-Alloy Seamless Pipe and Seamless Extruded Tube
  - 11. B251 Standard Specification for General Requirements for Wrought Seamless Copper and Copper-Alloy Tube
  - 12. B302 Standard Specification for Threadless Copper Pipe, Standard Sizes

## **GENERAL SPECIFICATION 15053 - ALUMINUM, COPPER & BRASS PIPE**

---

- B. The American Society of Mechanical Engineers (ASME):
    - 1. B1.20.1 Pipe Threads, General Purpose, Inch
    - 2. B16.15 Cast Copper Alloy Threaded Fittings: Classes 125 and 250
    - 3. B16.18 Cast Copper Alloy Solder Joint Pressure Fittings
    - 4. B16.22 Wrought Copper and Copper Alloy Solder-Joint Pressure Fitting
    - 5. B16.24 Cast Copper Alloy Pipe Flanges, Flanged Fittings, and Valves: Classes 150, 300, 600, 900, 1500 and 2500
    - 6. B31.1 Power Piping
    - 7. B36.10M Welded and Seamless Wrought Steel Pipe
    - 8. B36.19M Stainless Steel Pipe
    - 9. Boiler and Pressure Vessel Code Section VIII – Rules for Construction of Pressure Vessels, Division 1, Appendix 26
  - C. Expansion Joint Manufacturers Association (EJMA):
    - 1. Standards of the Expansion Joint Manufacturers Association
  - D. National Sanitation Foundation (NSF) International:
    - 1. Standard for Drinking Water Additives 61, Drinking Water System Components – Health Effects
- 1.05 DESIGN REQUIREMENTS
- A. Aluminum, copper and brass pipe and fittings shall conform to the latest Building Code of the City of New York in respect to plumbing and other applications covered by these laws.
  - B. Aluminum, copper and brass pipe shall conform to the latest standards of the American Society for Testing and Materials (ASTM), the American National Standards Institute (ANSI), the American Society of Mechanical Engineers (ASME), the Aluminum Association (AA), the Copper and Brass Research Association (CABRA), the Society of Automotive Engineers (SAE), the Manufacturer's Standardization Society (MSS), the American Welding Society (AWS), and National Pipe Thread (NPT).
  - C. Use only NSF61-approved materials in potable water lines.
- 1.06 SUBMITTALS
- A. Contractor shall submit Shop Drawings for approval of the Engineer before fabricating or installing pipe. Submittals shall include, but not limited to the following:

## **GENERAL SPECIFICATION 15053 - ALUMINUM, COPPER & BRASS PIPE**

---

1. Complete detailed shop drawings in conformance with the specified requirements. Include all data pertinent to the layout of the pipe even if such information is not specifically mentioned herein.
2. Drawings that show completely dimensioned piping layouts and schedules of all pipe, fittings, valves, expansion joints, flexible couplings, hangers, supports and other appurtenances.
3. Schedules of pipe, fittings and valves. Denote the material and thickness or class of all pipe, the type and material of all fittings and the rating and description of all valves.
4. Details of insulation, painting and similar work for all piping.
5. Details and materials of the support and hanging of pipe.
6. Points of location for pipe identification signs.
7. When any work is of special design show in large detail and completely describe and dimension.

### 1.07 DELIVERY, STORAGE AND HANDLING

- A. Deliver, store and handle all products and materials as specified in Contract Documents.

## PART 2 PRODUCTS

### 2.01 MANUFACTURERS

The following manufacturers are acceptable:

- A. Aluminum Pipe and Fittings:
  1. ALCOA, Pittsburgh, PA.
  2. Or approved equal.
- B. Brass Pipe and Fittings:
  1. Metalloy Industries, Inc., Alachua, FL.
  2. Or approved equal.
- C. Copper Pipe and Fittings:
  1. Pipe and Fittings
    - a. Mueller Industries, Inc., Memphis, TN.
    - b. NIBCO, Elkhart, IN.
    - c. Or approved equal.
  2. Flared Tube Fittings, Triple-Lok Fittings:
    - a. Parker Hannifin Corp., Cleveland, OH.

**GENERAL SPECIFICATION 15053 - ALUMINUM, COPPER & BRASS PIPE**

- b. Or approved equal.
- D. Threadless Copper Pipe and Fittings:
  - 1. Pipe:
    - a. Cambridge-Lee, formerly Reading Tube Corp., Reading, PA.
    - b. Or approved equal.
  - 2. Fittings: Flagg Brass, Flagg-Flow Bronze Fittings:
    - a. Cambridge-Lee, formerly Reading Tube Corp., Reading, PA.
    - b. Or approved equal.
- E. Wall Sleeve Annular Seals:
  - 1. Link Seal, as manufactured by Thunderline Corp., Stafford, TX.
  - 2. Metraseal, as manufactured by The Metraflex Corporation, Chicago, IL.
  - 3. The Pipe Seal, as manufactured by Flexicraft Industries, Chicago, IL.
  - 4. Or approved equal.

2.02 MATERIALS

- A. Aluminum Pipe, Tubing and Fittings
  - 1. Pipe: Provide aluminum pipe of Alloy 6061 and T6 temper conforming to ASTM B241, with sizes and dimensions corresponding to ASME B36.10M schedule numbered pipe.
  - 2. Where aluminum light wall pipe is shown or specified, the pipe shall be ANSI Schedule 10, corresponding to the sizes and dimensions of ASME B36.19M.
  - 3. Aluminum tubing shall be round, drawn tube conforming to ASTM B210, Alloy AA No. 6061-T6. Wall thickness of drawn aluminum tubing shall be as shown in the following schedule:

<b>Wall Thickness Of Aluminum Tubing</b>	
<b>Tubing Size (inch)</b>	<b>Wall Thickness (inch)</b>
1/8	.028
3/16	.035
1/4	.049
5/16	.058
3/8	.065

## GENERAL SPECIFICATION 15053 - ALUMINUM, COPPER & BRASS PIPE

Wall Thickness Of Aluminum Tubing	
Tubing Size (inch)	Wall Thickness (inch)
1/2	.065
5/8	.065
3/4	.083
7/8	.083
1	.083

4. Unless otherwise shown, specified or required, nominal lengths of aluminum pipe and tubing shall be approximately 12 feet. Mark aluminum pipe and tubing at the manufacturer's plant by approved means with the name or trademark of the manufacturer, schedule number or wall thickness, and the standards complied with.
5. **Welding and Threaded Fittings:** Provide aluminum forged welding fittings or cast threaded fittings conforming to ASTM B26/B26M or B108.
6. **Flanged and Coupling Connections:** Provide joints that are made with aluminum mechanical couplings in combination with grooved, flared or plain end pipe or that are flanged. For aluminum light wall pipe, unless specified or shown otherwise, couplings shall be of aluminum of the grooved end type.
  - a. When grooved couplings are used, roll the grooves into the pipe in conformance with the coupling manufacturer's specifications.
  - b. Cut grooves shall not be used.
  - c. Where grooved end couplings and fittings are specified or shown, they shall meet the requirements of Section 15056 - Pipe Couplings.
7. **Lubricating Compound:** Assemble fittings and couplings with an approved lubricating compound to prevent seizing of the connection and overstressing of the pipe.
  - a. Provide a lubrication compound which both lubricates and seals, for pipelines subject to internal pressure.
8. Connections to valves and other pipeline equipment shall be made with threaded adapters; such adapters shall be short lengths of Schedule 40 aluminum pipe having one end threaded, ASME B1.20.1 pipe threads, and the other end grooved for assembly with groove-type couplings or



plain for assembly with compression couplings. Where flanges are shown for connection to pipeline equipment or where insulated connections are shown, specified or required to prevent electrolytic corrosion between dissimilar materials, flanged adapters shall be provided. Flanged adapters shall be short lengths of Schedule 40 aluminum pipe having one end fitted with an aluminum flange, equivalent to ANSI 150 pound flange dimensions, and the other end grooved for assembly with groove-type couplings or plain for assembly with compression couplings.

**B. Brass Pipe and Fittings**

**1. Pipe**

- a. Unless otherwise shown or specified, provide red brass pipe that meets the requirements of ASTM B43.
- b. Provide pipe sizes, wall thicknesses and dimensions that meet the ASTM B251, B 43 Table 2 requirements for regular pipe.
- c. Nominal lengths of brass pipe shall be 12 feet, unless specified or approved otherwise. Each length shall be permanently marked by the manufacturer with name or trademark, type and conformity to standards.
- d. Provide piping with a rough finish, unless otherwise specified.

**2. Fittings**

- a. Provide brass pipe fittings that meet the requirements of ASME B16.15.
- b. Provide brass fittings rated for steam working pressures up to 125 psig and with a rough finish unless otherwise specified.
- c. Provide screwed unions made entirely of bronze, semi-finished, with ground joints.
- d. On all brass pipelines 3 inches in diameter or smaller, provide fittings conforming to ASTM B62, of 85-5-5-5 leaded red brass.
- e. Provide screwed type joints with clean cut, tapered and smooth threads that meet ASME B1.20.1 requirements.
- f. On all brass pipelines 4 inches in diameter or larger, provide bronze flanged fittings and companion flanges rated for steam working pressures up to 150 psi. Design flanged fittings to conform to ASME B16.24, 150 pound standards.
  - 1) For piping, use screwed-on companion flanges, shop assembled and faced true and at right angles to the pipe

center line. Field assembly of flanges and pipe will be permitted only if approved by the Engineer.

- 2) Use heavy machinery to screw on companion flanges until the end of the pipe projects beyond the face of the flange and a tight metal to metal joint is produced without evidence of heat in the threaded portion. Cut off the projecting end of the pipe flush with the flange face and take a light refacing cut across both the end of the pipe and the face of the flange at right angles to the pipe center line. Ream the pipe end to remove burrs and chips leaving a smooth interior surface.

C. Copper Pipe and Fittings

1. Small Copper Piping: For copper pipe 3 inches in diameter and smaller, provide Type K seamless, round, hard drawn copper tubing that meets ASTM B88 requirements. Provide tube sizes, dimensions and wall thickness conforming to ASTM B88, Table 1 for Type K tubing, unless otherwise specified. Provide nominal lengths of hard copper tubing in straight lengths of approximately 20 feet, unless otherwise specified.
  - a. Fittings: For copper tubing, use solder joint or flared end type fittings, as specified. No bending of hard copper tubing will be permitted, unless otherwise specified; make all bends and connections with suitable fittings.
    - 1) Provide flared tube fittings meeting the requirements of the SAE Hydraulic Tube Fittings standard. After flaring, anneal the joints before assembly. Flared fittings shall be of brass half-hard bar stock, ASTM B 16 (SAE 72) or of brass forgings, ASTM B 124, Alloy Number 2 (SAE 88). Assemble couplings and fittings to prevent overstressing the tubing. Where required, use anti-seize lubricating compound to prevent galling and to facilitate assembly.
    - 2) Solder Joint Fittings: Provide ASME B16.18, cast copper alloy or ASME B16.22 wrought copper and copper alloy fittings. Braze solder joint fittings and tubing in conformity to the specifications of Section 3 of the CABRA Copper Tube Handbook. Brazing alloy shall be copper-phosphorus alloy, Class BCuP-5, as specified by American Welding Society Spec. AWS A5.8.
  - b. Joints: Provide threaded or ASTM B32 lead-free soldered joints.

## **GENERAL SPECIFICATION 15053 - ALUMINUM, COPPER & BRASS PIPE**

---

2. Large Copper Piping: For copper pipe larger than 3 inches in diameter, provide regular seamless copper pipe that meets the ASTM B42 requirements.
    - a. Fittings: Provide solder type fittings of the same material as the pipe.
    - b. Joints: Use threaded or brazed joints.
  3. Potable Water Piping: Use ASTM B32 alloy Grade 95TA (95 percent tin and 5 percent antimony) solder for piping carrying potable water.
  4. Unacceptable Uses: Do not use copper pipe with soldered joints for transporting fuel oil or other flammable or toxic liquids inside buildings.
- D. Threadless Copper Pipe and Fittings
1. Provide hard drawn threadless copper pipe, standard pipe size pipe, conforming to ASTM B302 furnished in 20 foot lengths. Limit maximum internal working pressure to 200 psi as computed using the Code for Pressure Piping, ASME B31.1.
  2. Provide threadless bronze fittings with physical requirements meeting ASTM B62 for lines 2 inches and smaller, and ASTM B61 for lines over 2 inches.
  3. Assemble threadless copper pipe ("TP") with threadless bronze fittings brazed together with the copper-silver-phosphorus type of brazing alloy to form a uniform, tight joint. The alloy shall be Class BCuP-5, in accordance with American Welding Society Spec. AWS A5.8.
  4. Follow the brazing procedure specifications of the Copper and Brass Research Association (CABRA).
- E. Expansion and Swing Joints
1. When expansion joints are shown, specified or required, they shall be of the packless bellows type, of internally pressurized design for axial movements less than 4 inches, and of the externally pressurized design for axial movements 4 inches and greater.
  2. Bellows shall be of 18-8 stainless steel, of uniform curvilinear shape without circumferential welds and with not more than one longitudinal weld for each 10 inches of pipe diameter. Welds shall approximate the parent metal thickness without grinding, and metal thickness shall not be reduced by more than eight percent during forming.
  3. Bellows shall be designed in accordance with ASME Code, Section VIII, Appendix 26 or ASME B31.1. For the externally pressurized design, bellows shall be suitable for a minimum of 1000 full pressure/temperature cycles at operating conditions, and for the

internally pressurized design bellows shall be suitable for a minimum of 5000 full pressure/temperature cycles at operating conditions.

4. Expansion joints of the externally pressurized design shall have an internal carbon steel liner to prevent flow induced vibration and internal and external guides welded to the inner end of pipe and outer cover to guide bellows movement.
5. A carbon steel external cover designed for full line pressure and a liquid drain shall be provided.
6. For risers in new concrete structures, an allowance of 0.2 inches per floor shall be made to accommodate frame shortening.
7. The manufacturer shall provide EJMA calculations, empirical test results and/or evidence of satisfactory product performance under similar or more severe conditions to validate his designs. All joints shall be designed for 1.5 times operating pressure.
8. When connections are to be made to flanged pipe, expansion joints shall have flanged ends. An approved dielectric insulating device shall be provided to separate the carbon steel flanges from the flanges on aluminum or brass pipe. If connections are to be made to copper pipe, brass pipe with screwed joints, or aluminum pipe with other than flanged ends, the expansion joints shall have flanged or weld end, and adapter fittings and dielectric insulating devices shall be provided.
9. On brass and copper pipelines 2 inches or less in diameter rated at water working pressures up to 150 psi, all brass or bronze screwed end swing or swivel joints may be used, or the joints may be made up with nipples and fittings.

F. Sleeves and Wall Castings

1. Unless otherwise shown or specified, furnish and install suitable pipe sleeves at all points where pipes pass through walls or floors of structures. Sleeve material shall be ductile iron or steel as shown on the Contract Drawings or specified herein. Ductile-iron sleeves shall conform to the requirements of Section 15051 - Ductile and Cast Iron Pipe, and steel sleeves shall conform to the requirements of Section 15052 - Steel and Stainless Steel Pipe.

G. Wall Sleeve Annular Seals

1. Where pipes pass through walls, partitions or floors where fire-rated construction is not required, provide modular mechanical type seals consisting of interlocking synthetic rubber links shaped to continuously fill the annular space between the pipe and the wall sleeve. Provide an elastomeric element that is of the size, quantity, type and material that the manufacturer recommends for the intended service and that will

provide an effective hydrostatic seal. Bolts and nuts shall be stainless steel. Wall sleeve annular seals shall be approved equal to those manufactured by the companies listed in Paragraph 2.01E.

2. For all penetrations through fire-rated walls, partitions and floors, provide a permanent fire stop system. The fire stop system shall maintain the integrity of the wall or floor system for the rated time period and shall allow normal pipe movement without being displaced. The fire stop system shall be intumescent when exposed to flame or heat. Asbestos shall not be used as fire stop material.

- H. Drip Pans: Provide drip pan hangers and supports as specified for stainless steel ductwork in Section 15810 - Ductwork and Duct Accessories. Drip pans shall be constructed of 16-gauge Type 316 stainless steel. If welding is required to construct the drip pan, Type 316L stainless steel shall be used.

### PART 3 EXECUTION

#### 3.01 INSTALLATION

- A. General: Install all pipe and fittings in accordance with this Section, as shown on the Contract Drawings, and in accordance with the manufacturer's recommendations and approved shop drawings.
- B. Connections between Dissimilar Metals: Where connections are to be made between pipelines or equipment of dissimilar metals, make the connections using dielectric insulating couplings, unions or other approved dielectric insulating devices.
- C. Pipe Lengths: Full standard lengths of pipe shall be used in each pipe run in so far as possible. Shorter lengths than standard shall be used only to complete a straight run of pipe, to connect to established locations of valves, equipment, bends, and the like. Random lengths of pipe or cuttings from standard lengths shall not be coupled together when a full standard pipe length will fit in the pipe run.
- D. Reducing Fittings: Use reducing fittings for all changes in pipe size. Do not use bushings.
- E. Pipe Flexibility
  1. Make ample provisions for flexibility in all pipelines.
  2. Install branch tees on risers in locations that will allow the branch lines, when expanded by heat, to drain properly.
  3. Unless other forms of expansion compensation are specified, such as expansion joints, fabricate all runs of pipe subject to change in length shorter than their theoretical length to the extent of one half of the

expansion and erect them such that they may be free to expand without increasing the stresses imposed when cold.

4. When the foregoing method of compensation for expansion is not adequate, furnish and install in the pipelines expansion devices adequate to allow the lines to expand and contract freely without injury to any part of the piping system. The devices may be in the form of expansion joints, swivel joints, swing joints, pipe bends or flexible couplings, and shall include such anchors as may be shown or required to make the devices effective. A sufficient number of fittings and pipe lengths shall be used in connection with swing joints to assure the absence of distortion of either the pipelines or branches. Application guide and anchor requirements for expansion joints shall be in accordance with the recommendations of the manufacturer or the Standards of the EJMA.

F. Venting

1. Each high point in liquid lines shall be provided with a vent consisting of an automatic air release/vacuum relief valve and an outlet vent line. The automatic valve and vent line for pipelines up to and include 1-inch size shall be the same size as the carrier pipe. In larger carrier pipes, the valve and vent line shall be of the size specified or shown, but not smaller than 1 inch. The automatic valve shall have a cast or ductile-iron body and cover, stainless steel internals, and Viton or Buna N seal, unless otherwise specified. The outlet vent line from the valve shall be Schedule 80 CPVC and shall terminate at a point approximately 3 feet above the floor. A bronze ball valve shall be provided between the carrier pipe and the automatic valve to allow removal of the automatic valve for repair or replacement.
2. Where vent valves are so located that liquids discharged therefrom would cause damage to structure or equipment, the vent shall be piped to the nearest gutter or drain in an approved manner.

G. Drainage

1. Each low point in liquid lines shall be provided with not less than a 1-inch drain line. A bronze ball valve shall be provided at the connection to the carrier pipe and at the terminus approximately 3 feet above the floor. A quick connect coupling shall be provided at the end of the drain line for attachment of a hose. The drain line shall be Schedule 80 CPVC.
2. The means by which condensate is to be drained from lines conveying air, gas or steam depends upon the service and shall be provided in accordance with the requirements specified or shown for the specific application.

## **GENERAL SPECIFICATION 15053 - ALUMINUM, COPPER & BRASS PIPE**

---

- H. Hangers and Supports: Furnish and install supporting devices as specified under Section 15060 - Hangers and Supports.
  - I. Drip Pans: Provide drip pans under all metallic pipelines installed over electrical equipment and motors and conduct drainage to the nearest floor drain, gutter or other drainage system with 3/4-inch red brass pipe. Make the connection between the drip pan and the brass drain pipe leaktight, and pitch the drip pan uniformly toward the drain pipe at a slope not less than 1/8-inch per lineal foot.
  - J. Pipe identification signs and valve identification numbers shall be furnished and installed in conformity with Section 15076 - Piping and Equipment Identification.
- 3.02 CLEANING AND TESTING
- A. Cleaning: During construction, clean all piping before placement and keep the lines free from every kind of foreign matter. All pipelines shall be left thoroughly clean to the satisfaction of the Engineer. Flush all process and potable water pipelines with clean water.
  - B. Test all pipelines for leakage in conformance with Section 02505 - Leakage Tests.
- 3.03 PAINTING AND INSULATION
- A. Painting shall conform to Section 09900 - Painting.
  - B. Piping insulation shall conform to Section 15081 - Piping Insulation.
- 3.04 DISINFECTION
- A. Disinfect all potable water pipelines in accordance with Section 15141 - Disinfection.

END OF SECTION

**GENERAL SPECIFICATION 15053 - ALUMINUM, COPPER & BRASS PIPE**

NO TEXT ON THIS PAGE



**SECTION 15056  
Pipe Couplings**

**PART 1 GENERAL**

**1.01 SECTION INCLUDES**

- A. The Contractor shall provide sleeve-type and groove-and-shoulder-type couplings in pipelines as shown, specified and required.
- B. The following index of this Section is included for convenience:

<u>Article</u>	<u>Title</u>	<u>Page</u>
		15056-
PART 1	GENERAL .....	1
1.01	Section Includes .....	1
1.02	Payment.....	1
1.03	Related Sections.....	1
1.04	References.....	1
1.05	Design Requirements .....	2
1.06	Submittals .....	2
PART 2	PRODUCTS.....	3
2.01	Manufacturers .....	3
2.02	Products.....	4
2.03	Painting .....	9
PART 3	EXECUTION.....	9
3.01	Installation.....	9

**1.02 PAYMENT**

- A. Unless otherwise specified, no separate payment will be made for pipe couplings. The costs of pipe couplings shall be included in the price for the associated pipelines.

**1.03 RELATED SECTIONS**

- A. Section 09900 - Painting
- B. Section 15052 - Steel and Stainless Steel Pipe

**1.04 REFERENCES**

- A. ASTM International:
  - 1. A47 Ferritic Malleable Iron Castings.

## GENERAL SPECIFICATION 15056 - PIPE COUPLINGS

---

2. A193/A193M Alloy-Steel and Stainless Steel Bolting Materials for High-Temperature Service.
  3. A194/A194M Carbon and Alloy Steel Nuts for Bolts for High Pressure or High Temperature Service, or Both.
  4. A276 Stainless and Heat-Resisting Steel Bars and Shapes.
  5. A283/A283M Low and Intermediate Tensile Strength Carbon Steel Plates.
  6. A536 Ductile Iron Castings .
  7. A744 Corrosion-Resistant Iron-Chromium-Nickel and Nickel-Base Alloy Castings for Severe Service.
  8. B26 Aluminum-Alloy Sand Castings.
  9. D2000 Classification System for Rubber Products in Automotive Applications.
- B. The American Society of Mechanical Engineers (ASME):
1. B1.1 Unified Inch Screw Threads (UN and UNR Thread Form).
  2. B18.2.2 Fasteners in Customary Uses - Hex Nuts.
  3. B31.1 Power Piping.
- C. American Water Works Association (AWWA):
1. C606 Joints, Grooved and Shouldered Type.
  2. Manual M11 Steel Pipe - A Guide for Design and Installation.

### 1.05 DESIGN REQUIREMENTS

- A. Pipe couplings for making field joints between plain end, grooved end, and shouldered end pipe and fittings shall meet the requirements of the Code on Power Piping, ASME B31.1.
- B. Coupling design and construction shall facilitate easy assembly in the field.
- C. Flexible couplings shall be designed and constructed to insure permanently tight joints under all conditions of expansion, contraction, shifting and settlement to which the pipelines may be subjected as a result of the operation and layout of the process system in which they are installed.
- D. Rigid couplings shall be designed and constructed to provide a tight joint and prevent pipe movement at the joint.

### 1.06 SUBMITTALS

- A. Contractor shall submit Shop Drawings, Submittals shall include, but not be limited to:

## GENERAL SPECIFICATION 15056 - PIPE COUPLINGS

---

1. Location in pipeline
  2. Catalog data showing dimensions and materials of component parts
  3. Harnessing, where required
  4. Working and test pressures
- B. Contractor shall forward process air piping layout drawings to the coupling manufacturer for review and design recommendations. The coupling manufacturer shall address as minimum the allowable angular pipe deflection, flexibility, contraction and expansion based on the maximum range of operating conditions.

### PART 2 PRODUCTS

#### 2.01 MANUFACTURERS

- A. The following manufacturers are acceptable. Equivalent products from other manufacturers may be submitted for approval.
- B. Sleeve-type Couplings:
1. Dresser Manufacturing Division Dresser Industries, Bradford, PA
    - a. For steel pipelines, Style 38.
    - b. For ductile iron pipelines:
      - 1) 12" and smaller - Style 138.
      - 2) Larger than 12" - Style 38.
    - c. To join different types and sizes of pipe, Style 162.
  2. Smith-Blair Company, Texarkana, AR:
    - a. For steel pipelines, Type 411.
    - b. For ductile iron pipelines:
      - 1) 12" and smaller - Type 441.
      - 2) Larger than 12" - Type 411.
    - c. To join different types and sizes of pipe, Type 441.
  3. Or approved equal
- C. Groove- and Shoulder-type Couplings:
1. Victaulic, Easton, PA:
    - a. For steel pipelines:
      - 1) Grooved, flexible, Style 77.
      - 2) Grooved, rigid, Style 07.

- 3) Shouldered, Style 44.
- b. For ductile iron pipelines:
  - 1) Grooved, flexible, Style 31 with flexible radius grooves.
  - 2) Grooved, rigid, Style 31 with rigid radius grooves.
  - 3) Shouldered, Style 31.
- c. For stainless steel pipelines:
  - 1) Grooved, flexible, Style 77S.
  - 2) Grooved, rigid, Style 008.
- d. For aluminum pipelines:
  - 1) Grooved, flexible, Style 77A.
- e. For copper pipelines:
  - 1) Grooved, rigid, Style 606.
- f. For PVC pipelines:
  - 1) Grooved, flexible, Style 775.
- g. For High Density Polyethylene (HDPE) pipelines:
  - 1) Plain end, rigid, Style 995.
- 2. Or approved equal
- D. Groove- and Shoulder-type Fittings as manufactured by:
  - 1. Victaulic, Easton, PA for Full-Flow Fittings.
  - 2. American Cast Iron Pipe Co., Birmingham, AL.
  - 3. U.S. Pipe and Foundry Co., Bessemer, AL.
  - 4. Or approved equal.
- E. Bolted Split-Sleeve Type Couplings as manufactured by:
  - 1. Victaulic, Easton, PA for Depend-O-Lok, Type 1 or 2.
  - 2. Or approved equal.

## 2.02 PRODUCTS

- A. Couplings shall be either one of the following three types:
  - 1. Sleeve-type couplings shall be solid (axially un-split/unbolted) and have a middle ring or sleeve placed around the pipe joint. The middle ring shall be sealed by two wedge-shaped gaskets evenly compressed by follower flanges or rings tightened by bolts and nuts.

## GENERAL SPECIFICATION 15056 - PIPE COUPLINGS

2. Groove- and shoulder-type couplings shall have a C-shaped (cross section) sealing gasket placed around the joint. The gasket shall be enclosed in a split-type housing which shall engage shoulders or grooves in the pipe. The housing shall be assembled by bolts and nuts.
  3. Bolted split sleeve type couplings as detailed under Paragraph F.
- B. Bolts and Nuts
1. Bolts for sleeve-type and groove- and shoulder-type couplings shall be Type 316 stainless steel, ASTM A 193/A 193M, Grade B8, Class 2. Nuts shall be Type 316 stainless steel conforming to ASTM A194/A194M. Bolts shall have American Screw Threads, Coarse Thread Series, ASME B1.1. Nuts shall be American Standard Heavy Dimension Series, ASME B18.2.2.
  2. For all sleeve-type couplings, bolts shall be double radius head or buttonhead track type. The collars under the heads shall fit oval or square holes in the follower rings.
  3. For all groove-and shoulder-type couplings, bolts shall be track type oval neck bolts. The collars under the heads shall engage the oval slots in the housing.
- C. Sleeve-type couplings shall be of steel construction for steel pipe lines. Sleeve-type couplings for ductile iron pipelines shall be constructed of ductile iron or steel for pipe sizes 12 inch and smaller and shall be constructed of steel for pipes larger than 12 inch.
1. For Steel Pipe Lines:
    - a. The middle ring or sleeve and the follower rings or flanges shall be steel, ASTM A 283/A 283M (Grade A). The middle ring or sleeve shall have flared or beveled ends. The follower rings or flanges and the middle ring or sleeve shall be true circular sections free from irregularities, flat spots or surface defects.
    - b. The middle ring or sleeve shall not have a center pipe stop, unless otherwise specified, and shall have the following minimum dimensions:

<b>Pipe Diameter (inches)</b>	<b>Middle Ring Thickness (inches)</b>	<b>Middle Ring Length (inches)</b>
8 and Smaller	1/4	5
10-30	3/8	7
Over 30	1/2	10

## GENERAL SPECIFICATION 15056 - PIPE COUPLINGS

---

- c. After welding, welded steel follower rings shall be sized and tested by cold expanding a minimum of one (1) percent beyond the yield point.
  2. For Ductile Iron Pipe Lines:
    - a. The middle ring or sleeve shall be ductile iron, ASTM A536. The middle ring or sleeve shall have flared or beveled ends. Follower rings or flanges shall be of ductile iron, ASTM A536, or malleable iron, ASTM A47 (Grade 32510), for pipe sizes 12 inches and smaller, and shall be of steel ASTM A283/A283M (Grade A) for pipe larger than 12 inches.
    - b. The middle ring shall not have a center pipe stop, unless otherwise specified, and shall have the same minimum dimensions as specified above for couplings for steel pipe.
  3. Gaskets shall be resilient, wedge-shaped gaskets with a maximum angle of 40 degrees at the wedge end. Gasket material shall be compatible with the type and temperature of the fluid in the pipeline, and shall be the material recommended by the manufacturer for the service unless otherwise specified.
  4. The maximum working pressure of the sleeve-type couplings shall not be less than 250 psi for pipe sizes smaller than 54 inch, and not be less than 200 psi for pipe larger than 54 inch.
- D. Groove- and Shoulder-type Couplings:
  1. Couplings may be of the grooved type for steel pipe in sizes up to and including 24 inches. For steel pipe larger than 24 inches, suitable welded steel collars, Victaulic Vic-Ring Type C or Type E, or approved equal, shall be welded to the pipe ends. Unless otherwise specified, groove-type couplings shall conform to the requirements of AWWA C606.
  2. Housing shall be in two or more parts, closely fitting the pipe and gasket. Housing material shall be ductile iron, ASTM A536 (Grade 654512), except for stainless steel and aluminum pipelines, which shall have housings of Type 316 stainless steel, ASTM A744 Grade CF-8M, and aluminum, ASTM B26, Alloy 356-T6, respectively.
  3. Gaskets shall be of materials compatible with the type and temperature of the fluid in the pipeline, and shall be of the material as recommended by the coupling manufacturer for the service unless otherwise specified. Gaskets shall be molded so that internal pressure tightens the seal. All gaskets shall be continuous, uniform in texture, and free from surface blemishes and defects.

## GENERAL SPECIFICATION 15056 - PIPE COUPLINGS

---

E. Groove- and Shoulder-type Fittings:

1. Grooved end fittings for steel and ductile iron pipe in sizes up to and including 24 inches shall be cast of ductile iron with working pressure ratings not less than the following:

Nominal Pipe Size (Inches)	Working Pressure (psi)
3/4" - 6"	1,000
8" - 12"	800
14" - 22"	300
24"	250

2. For steel and ductile iron pipe larger than 24 inches, fittings shall be provided with shoulders. Working pressure ratings shall not be less than 150 psi. Fabricated steel fittings shall be provided with extra-long end pieces to suit the coupling.
3. Grooved end fittings for stainless steel pipe shall be Type 304 of the thickness schedule specified in the contract documents.
4. Grooved end fittings for aluminum pipe in sizes 1 inch through 8 inches shall be of aluminum alloy 356 T6 conforming to ASTM B26, and shall be equal to Victaulic full-flow aluminum fittings. Working pressure ratings shall be not less than 500 psi for fittings in sizes 1 inch through 6 inches and not less than 400 psi for 8 inch size fittings.
5. Grooved end fittings for copper pipe shall be provided with rolled grooves and shall be designed for a working pressure not less than 300 psi.

F. Bolted Split-Sleeve Type Couplings:

1. Couplings for large diameter steel piping shall be bolted, split-sleeve type consisting of four basic components: two-piece housing, gasket assembly, bolts and nuts with restraining end rings as required for pipe restraint. The selected couplings shall be designed for the type, size and working pressure of the pipe with which they are to be used.
2. Coupling housing shall be manufactured from Type 316 stainless steel for stainless steel pipe and from carbon steel for carbon steel pipe.
3. The split-sleeve coupling shall be constructed with a double arch cross section which closes around either:
  - a. pipe section ends that have been smoothed for expansion or contraction, or

## GENERAL SPECIFICATION 15056 - PIPE COUPLINGS

---

- b. pipe section ends with steel end rings affixed for restraining purposes.
- 4. The coupling shall confine an elastomeric gasket beneath the sleeve arches to create a radial seal as the coupling closes.
- 5. Elastomeric gasket materials shall have properties as designated by ASTM D2000 suitable for air service up to 240°F with intermittent exposure to 280°F.
- 6. Gasket sealing members shall consist of two O-ring gaskets and an elastomeric sealing pad bonded to an integral sealing plate. Internal pressure shall not be a requirement for fully completing the sealing function.
- 7. Restraining rings shall be furnished with the couplings and shall be of the same material as the coupling housing.
  - a. Restraining rings for fixed type couplings shall be shop welded to the piping by the piping fabricator.
  - b. The restraining rings shall be forwarded to the piping fabricator for shop mounting and welding in place.
  - c. The coupling manufacturer's recommendation for size and amount of welding required for properly attaching the restraining rings shall be followed without exception.
- 8. When deflection is required at a pipe joint, a flexible coupling shall be provided. Flexible couplings shall be equal to Depend-O-Lok EXE Type 1 or Type 2. Type 2 couplings are Type 1 couplings with shoulders added to provide more angular deflection within the pipe joint.
  - a. Minimum deflection for Type 1 couplings shall be as follows:

Nominal Pipe Size, Inches	Minimum Deflection Degrees
8-14	4.50
16-24	4.00
30 & 36	3.00
42-54	2.00
60	1.75
66 & 72	1.50
84 & larger	1.00



## GENERAL SPECIFICATION 15056 - PIPE COUPLINGS

---

- b. Maximum deflection for Type 2 couplings shall be as recommended by the manufacturer.
  - c. Coupling width shall not be less than 10 inches for pipe sizes 8 inch through 84 inch, and not less than 12 inches for larger size pipe.
  - d. Minimum wall thickness of couplings shall be computed by the following formula:
9. Bolts, nuts and miscellaneous hardware shall be furnished by the

$$t = \frac{Pd}{2s}$$

Where:

- P = Design pressure in psi
- d = Pipe O.D. in inches
- s = 18,000 psi design stress

coupling manufacturer and shall be Type 316 stainless steel conforming to ASTM A276 and having a minimum tensile strength of 85,000 psi.

### 2.03 PAINTING

- A. All surfaces of the middle and follower rings of all sleeve-type couplings and the housing of all groove- and shoulder-type couplings shall be shop painted in conformance with the requirements of Section 09900 - Painting.

## PART 3 EXECUTION

### 3.01 INSTALLATION

- A. Ends of pipe, fittings and couplings shall be cleaned of all scale, dirt and thick outside coatings. Before assembly, the ends of pipe and/or fittings and the outside of the coupling gasket shall be lubricated as recommended by the manufacturer. Fasteners shall be assembled using a thread lubricant equal to G-N paste (Molycote) as manufactured by Dow-Corning, Auburn MI, or approved equal.
- B. Couplings shall be assembled by tightening diametrically opposite bolts evenly and progressively. Bolts on sleeve-type couplings shall not be tightened beyond the point of stretching (when the mill scale on the shank begins flaking off). Bolts on groove- and shoulder-type couplings shall be tightened only until there is metal to metal contact between housing segments and the pipe.
- C. Field Assembly of Groove-type Couplings. Field grooving of pipe shall not be done unless approved by the Engineer, and then shall be limited to steel pipe 24

## GENERAL SPECIFICATION 15056 - PIPE COUPLINGS

---

- inches or under nominal diameter and to ductile and cast iron pipe 12 inches or under nominal diameter. Field grooving shall be done only with special tools provided by the coupling manufacturer.
- D. Harness for Sleeve-type Couplings. In all pipelines under pressure, and elsewhere where shown, specified or required, sleeve-type couplings shall be harnessed.
1. On all pressurized steel pipe, cast steel "crow-foot" lugs shall be welded on diametrically opposite sides of the pipe, and the joint shall be harnessed with stainless steel tie-bolts and nuts. The dimensions, sizes, spacing and materials for lugs, tie-bolts and nuts shall be based on the use of a minimum of two bolts and four lugs per joint, in conformity with Section 13 (Table 13.4) of AWWA Manual M11 or the standard specifications of the coupling manufacturer for the pipe size, wall thickness and test pressure specified. Welding shall conform to the requirements specified under Section 15052 - Steel and Stainless Steel Pipe.
  2. On all pressurized ductile iron pipe, couplings shall be harnessed with stainless steel tie bolts and nuts connected to flanges or fittings installed on the pipe on each side of the coupling as shown, specified or required for the pipe sizes and specified test pressures. The harnessed length from flange to flange shall not exceed 3 feet.

END OF SECTION

**SECTION 15060  
Hangers and Supports**

**PART 1 GENERAL**

**1.01 SECTION INCLUDES**

- A. Contractor shall provide all hangers, supporting devices and appurtenances shown, specified or required for pipes, fittings, valves and other in-line equipment.
- B. Included in this classification are rod hangers; clevis hangers, spring hangers; stanchion, roller and pipe pole supports and saddle stands; supports of structural steel; concrete saddles, concrete anchor blocks and bases, and all necessary guides, restraints, fastening devices, anchor bolts, pipe anchors and appurtenances.
- C. Contractor shall provide all temporary pipe supports required during construction.
- D. Contractor shall design all piping support systems in accordance with the requirements of this Section unless otherwise shown or specified.
- E. The following index of this Section is included for convenience:

<u>Article</u>	<u>Title</u>	<u>Page</u>
		15060-
PART 1	GENERAL .....	1
1.01	Section Includes .....	1
1.02	Related Sections.....	2
1.03	Payment.....	2
1.04	References.....	2
1.05	Design Requirements .....	3
1.06	Submittals .....	6
1.07	Delivery, Storage And Handling.....	7
PART 2	PRODUCTS.....	7
2.01	Manufacturers .....	7
2.02	Materials .....	7
2.03	Hangers And Supports .....	8
2.04	Accessories .....	11
2.05	Pipe Insulation Protection.....	13
2.06	Pipe Anchors And Braces .....	13
2.07	Inspection.....	14
2.08	Galvanizing.....	14
PART 3	EXECUTION.....	14

## GENERAL SPECIFICATION 15060 – HANGERS AND SUPPORTS

---

3.01	General.....	14
3.02	Spacing Of Hangers And Supports.....	15
3.03	Painting And Coating.....	16
3.04	Testing.....	16
1.02	RELATED SECTIONS	
A.	Section 03300 - Cast-in-Place Concrete	
B.	Section 03600 - Grout	
C.	Section 05081 - Galvanizing	
D.	Section 05501 - Metal Fabrications	
E.	Section 09900 - Painting	
1.03	PAYMENT	
A.	No separate payment will be made for hangers and supports unless otherwise specified in the Contract Documents.	
1.04	REFERENCES	
A.	The Manufacturers Standardization Society of the Valve and Fitting Industry:	
1.	MSS SP-58 - Pipe Hangers and Supports - Materials, Design and Manufacture.	
2.	MSS SP-59 - Short Radius Welding Fittings.	
3.	MSS SP-69 - Pipe Hangers and Supports - Selection and Application.	
4.	MSS SP-89 - Pipe Hangers and Supports - Fabrication and Installation Practices.	
5.	MSS SP-90 - Guidelines on Terminology for Pipe Hangers and Supports.	
B.	ASTM A 36 - Standard Specification for Carbon Structural Steel.	
C.	ASTM A 48 - Standard Specification for Gray Iron Castings.	
D.	ASTM A 123 - Specification for Zinc (Hot-Dip Galvanized) Coatings on Iron and Steel Products.	
E.	ASTM A 276 - Standard Specification for Stainless and Heat-Resisting Steel Bars and Shapes.	
F.	ASTM A283 - Standard Specification for Low and Intermediate Tensile Strength Carbon Steel Plates, Shapes and Bars.	
G.	ASTM A778 - Standard Specification for Welded, Unannealed Austenitic Stainless Steel Tubular Products.	

- H. ASME - B31.1 - Power Piping.
  - I. N.Y. Spec 32-P-6 - Pipe, Special Castings, Valve Box Castings: Cast-Iron.
  - J. Latest Edition of the New York City Building Code.
- 1.05 DESIGN REQUIREMENTS
- A. Contractor shall provide hangers and supports of sufficient strength to maintain the pipelines and appurtenances in proper position and alignment under all operating conditions.
  - B. Contractor shall provide the services of a New York State Registered Professional Engineer to design the supports for all pipelines and appurtenances, for all weights, forces and applied pressures. In the design of hangers, supports and anchors, unless otherwise shown or specified, pipe pressures shall be the maximum test pressures specified for pipelines carrying gases and twice the maximum test pressures specified for pipelines carrying liquids. The pipe support designer shall have a minimum of 5 year experience in the design of pipe supports and have completed at least 5 successful pipe support projects of equal complexity as the systems specified.
    - 1. Pipe support design shall include load and movement calculations.
    - 2. The following loads shall be included in pipe support design and pipe stress analysis:
      - a. Gravity Force, including weight of pipeline and appurtenances, contents, insulation, etc.
      - b. Thermal Expansion Force developed by the restraint of free end displacement of the piping.
      - c. Hydrostatic Forces developed by internal pressure during operation of the piping system.
      - d. Loading due to expansion joint reaction forces.
      - e. Seismic forces, as required by the latest edition of the New York City Building Code.
    - 3. Supports, guides and anchors for flexible couplings and expansion joints shall be in accordance with the coupling and joint manufacturer's specification and the standards of the Expansion Joints Manufacturers Association.
    - 4. Wherever possible, pipe supports shall be designed using manufacturer's standard catalog products.
    - 5. Hangers and Supports for piping systems subject to thermal expansion and contraction, or to similar movements imposed by other sources,

## GENERAL SPECIFICATION 15060 – HANGERS AND SUPPORTS

---

- shall be designed to provide flexibility, and pipe stress analysis shall be provided.
6. Where resonance with imposed vibration and/or shock occurs during operation, suitable dampeners, restraints, anchors, etc., shall be added to remove those effects.
  7. Occasional load calculations and pipe stress analysis shall be provided where required by the Contract Documents, Building Codes or Standards. Occasional loads include:
    - a. Seismic forces.
    - b. Pressure waves produced by sudden changes in fluid momentum, commonly referred to as water hammer.
    - c. Wind, snow or ice loads.
    - d. Safety valve thrust loads
  8. Stressors in hangers, rods and brackets shall be in accordance with Table 2 of MSS-SP-58.
- C. All hangers and supports shall conform to the applicable requirements of ASME B31.1, MSS SP-58, SP-59, SP-69 and SP-90, except as modified herein, and be of standard manufacture wherever possible, and best suited for the service required.
- D. Unless otherwise approved, all hangers, supports and concrete inserts shall be listed with Underwriters' Laboratory, Inc.
- E. General Requirements:
1. Pipe and appurtenances connected to equipment shall be supported in a manner to prevent any stress being imposed on the equipment. When manufacturers have indicated requirements that piping loads shall not be transmitted to their equipment, certification shall be submitted stating that requirements have been complied with.
  2. Where practicable, piping shall be run in groups and parallel to building walls. A minimum clearance of one inch shall be provided between pipe and other work.
  3. Hangers or supports shall be provided at all locations where piping changes direction.
  4. Hangers and supports shall be capable of adjustment after placement of piping.
  5. Types of hangers and supports shall be kept to a minimum.
  6. Suspended or supported ductile iron pipe shall have a hanger or support adjacent to each hub or flanged end.

7. Vertical piping shall be supported at each floor and between floors by stays or braces to prevent rattling and vibration.
8. Hanger rods shall be straight and vertical. Chain, wire, strap or perforated bar hangers shall not be used. Hangers shall not be suspended from piping.
9. Contact between dissimilar metals shall be prevented by use of copper plated, rubber or vinyl coated hangers or supports.
10. Hangers and supports shall provide for expansion and contraction throughout the full operating temperature range.
11. Any required pipe supports, for which the supports called for in this Section are not applicable, shall be fabricated or constructed from standard stainless steel shapes, concrete and anchor hardware, and shall be subject to the approval of Engineer.
12. Where hanger or support spacing does not correspond with joist or rib spacing, structural steel channels shall be attached to joists or ribs, and the pipes suspended therefrom.
13. All points of adjustment for pipe and duct hanger rods shall be locked securely in place using double-nutting. Double-nutting means two nuts torqued directly against each other under each point of adjustment in addition to a third nut on top of the bracket. Damaging threads or tack welding as a method of locking adjustment is not permitted.
14. All threaded assemblies shall be double nutted or provided with pinned nuts. Alternately, tack welding of bolted assemblies may be acceptable unless provisions for vertical adjustment is required.
15. Except where otherwise shown or required, horizontally valves 6-inches and larger shall be supported on each side of the valve, by pipe hangers or supports.
16. At all flexible couplings, supports shall be placed on each side and as close to the coupling as possible. Supports shall be the guide type which prevent axial movement from resulting in pipe deflection and misalignment.
17. Supports, anchorage and guidance for grooved end pipe shall be in accordance with the applicable sections of these specifications and the recommendations of the manufacturer.

#### 1.06 SUBMITTALS

- A. Contractor shall submit the Shop Drawings for approval of the Engineer. Submittals shall include, but not be limited to:
  1. Name and qualifications of the support and hanger engineer.

2. Detailed Shop Drawings showing all hangers and supports for each piping system. Shop Drawings shall show location, installation, material, loads, forces, stresses and deflections of all hangers and supports. Reaction forces imparted to structures to which hangers and supports are attached shall be shown.
  3. Manufacturer's catalogs and engineering data on all hangers and supports.
  4. Load ratings.
  5. Materials.
  6. Installation details.
  7. All drawings and specified or required design calculations, signed and sealed by a New York State registered professional engineer.
- B. Contractor shall provide detailed drawings of each pipe support. Each drawing shall contain enough information to verify the pipe support design and to allow the manufacture of the device. At a minimum, the Contractor shall submit:
1. Scaled details of the device with dimensions.
  2. A table of applied forces and moments.
  3. A complete bill of materials.
  4. An isometric showing the applied forces and moments.
  5. Detailed connections to existing structure.
  6. Shop and field welds.
- C. Each submittal shall have the following:
1. A unique identification number and revision level.
  2. Stamp of a New York State registered professional engineer experienced in pipe support design as specified in Article 1.05B.

1.07 DELIVERY, STORAGE AND HANDLING

- A. Equipment and materials shall be delivered to the site to insure uninterrupted progress of the Work. Pipe hanger inserts which are to be embedded in cast-in-place concrete shall be delivered in ample time not to delay the Work.
- B. Equipment and materials shall be stored to permit easy access for inspection and identification, and shall be kept in covered storage off the ground, using pallets, platforms or other supports. They shall be protected from condensation, corrosion and deterioration.



**PART 2 PRODUCTS**

**2.01 MANUFACTURERS**

- A. Pipe hangers, supports and appurtenances shall be standard products of the manufacturers listed herein.
- B. Each type of hanger and support shall be the product of a single manufacturer.

**2.02 MATERIALS**

- A. Materials for hangers and supports of metallic construction shall conform to ASME B31.1 and to the following standards:
  - 1. Structural Steel, ASTM A 36 and A 283.
  - 2. Iron Castings, ASTM A 48 (Class No. 35).
  - 3. Stainless Steel, ASTM A 276.
    - a. Type 316 stainless steel for non-welded items.
    - b. Type 316L stainless steel for welded or fabricated items.
    - c. Tensile Strength 70,000 psi minimum.
    - d. Yield Strength 25,000 psi minimum.
    - e. Elongation in 2 inches 35%.
    - f. Reduction of area 45%.
  - 4. Stainless Steel Pipe and Tube, ASTM A778, Type 316L stainless steel.
- B. Pipe supports, hangers, brackets, guides, restraints, rods, bolts, nuts and anchors shall be Type 316 stainless steel. Concrete inserts shall be of malleable iron with galvanized finish.
- C. Pipe rolls, including stands and bases, shall be of cast iron, hot-dipped galvanized conforming to ASTM A123.
- D. Only new materials shall be provided.
- E. Hangers and supports shall conform to MSS-SP-58, Table 2.
- F. Proprietary fiberglass reinforced plastic supports and hangers for use with small diameter chemical and thermoplastic pipe shall be as specified herein and approved by the Engineer.
- G. Expansion anchors for use in existing concrete structure shall be made of Type 316 stainless steel.

**2.03 HANGERS AND SUPPORTS**

- A. Hangers and supports where shown shall be in accordance with the Contract Drawings. Hangers and supports not shown shall comply with MSS SP-58.

## GENERAL SPECIFICATION 15060 – HANGERS AND SUPPORTS

---

- B. All hangers and supports shall allow minimum 3-inches of vertical adjustment.
- C. Hangers and Supports shall be of the following types:
  - 1. Hangers for Single Pipes:
    - a. Single pipes shall be supported by hangers suspended by rods from structural steel members, inserts in concrete ceilings and beams, bottom of trapeze hangers and wall mounted steel angle brackets. The strength of the rod shall be based on its root diameter.
    - b. Except for piping subject to thermal expansion and contraction or as otherwise specified herein, pipe hangers shall be adjustable clevis type MSS SP-58 Type-1.
    - c. Piping subject to thermal expansion and contraction shall be supported on rollers.
  - 2. Hangers or Supports for Multiple Pipes:
    - a. Multiple pipes, running parallel in the same horizontal plane, and adjacent to each other, shall be suspended by trapeze type hangers or supported on wall brackets. Trapeze hangers shall consist of channel sections supported from threaded rods or attached to concrete walls, columns or structural steel support members.
    - b. Except as otherwise specified herein, pipe anchors used for attaching pipe to trapeze or multiple pipe wall brackets, shall be anchor or pipe chairs as required.
  - 3. Supports for Single Pipe:
    - a. Single pipes located in a horizontal plane close to the floor shall be supported by one of the methods specified herein or as shown on the Contract Drawings.
    - b. Pipes shall be supported by adjustable stanchions, pipe saddle or roll supports with "U" bolts. Stanchions shall provide at least 4-inches adjustment and be flanged-mounted to floor.
    - c. Stanchions and saddle stands shall be of Type 316L stainless steel.
    - d. Pipe pole supports for pipe runs above ground, out-of-doors, and where otherwise required, shall consist of a suitable length of stainless steel pipe set upright in at least four feet of concrete; two stainless steel angles secured to the top of the pipe, at right angle and on each side; a stainless steel plate welded to the top of the angles to serve as a horizontal support for the pipes.

Supports shall be provided with attachments in the form of stands, clamps, rolls, rods or similar devices of the screw adjustable type in the vertical direction.

- e. Where specified or shown, column supports of built-up welded stainless steel shall be provided, as approved by the Engineer.
  - f. Pipe rollers shall be cast ductile iron, unless otherwise shown or specified herein. Hardware and appurtenances shall be stainless steel.
4. Wall Supported Pipes: Single or multiple pipes located adjacent to walls, columns or other structural members, and an excessive distance from ceilings or underside of beams, shall be supported using stainless steel wall brackets, MSS SP-58 Type 32 or 33. Where pipes rest on top of bracket pipe supports, attachments shall meet the requirements specified under Paragraph 2.b above.
5. Supports for Base Elbows: Where pipes change direction from horizontal to vertical through a bend, a welded or cast base anchor support shall be installed at the bend to carry the load.
6. Supports for Vertical Pipes: Pipe riser clamps shall be used to support all vertical pipes extending through floor slabs. Riser clamps shall be MSS SP-58 Type 42 or 8. Insulation shall be removed from insulated pipes prior to installing riser clamps.
7. Supports for Process Air Piping:
- a. Air piping shall be supported on stainless steel saddle type supports in the locations shown on the Contract Drawings and as specified herein. Fixed supports, as located on the Contract Drawings, shall hold the pipe firmly in place, preventing any movement. Sliding supports, as located on the Contract Drawings, shall allow longitudinal movement of the pipe to account for thermal expansion. Guides, as located on the Contract Drawings, shall allow for longitudinal pipe movement while preventing lateral movement and maintaining alignment.
  - b. Supports shall be fabricated Type 316L stainless steel. Saddles shall support 120 degrees of the pipe circumference and at least 12-inches along the length of the pipe. Saddles shall be bolted to the structural steel or concrete slab supports. Straps shall be of Type 316 stainless steel. All sliding supports shall be provided with 8-inch wide hold-down straps. Straps shall not clamp down on the pipe, but shall allow the pipe to slide on the saddle to permit thermal expansion.

- c. All sliding supports shall have a resilient bearing pad of Teflon attached to the saddle to allow the pipe to slide on the saddle to permit thermal expansion.
  - d. All hangers from overhead supports shall be saddle or cradle-type hangers which shall support the lower 120 degrees of pipe circumference and a minimum length equal to one quarter the pipe diameter, but not have less than 6 inches or more than 12 inches. Where pipe is supported from existing slabs, new through- slab hanger rods shall be used instead of expansion bolts, except where otherwise authorized by the Engineer.
8. Supports for Pipelines with Thermal Expansion:
- a. Pipe rolls for single rod hangers: Stainless steel frame construction, ductile iron roller and stainless steel roller rod provided with threaded nuts; vertical adjustment permitted; for pipe sizes 6 inches or less unless otherwise approved.
  - b. Pipe rolls for double rod hangers: Ductile iron roller, stainless steel roller rod, malleable iron threaded sockets which permit vertical adjustment.
9. Supports for Pipelines Subject to Temperatures Greater than 300 F: Spring hangers of heavy stainless steel construction.
10. Supports for Thermoplastic Pipes: All thermoplastic pipe attachments shall have a continuous bearing cradle or saddle on the lower 120 degrees of pipe circumference and a minimum length of one quarter pipe diameter, but not less than 6 inches nor more than 12 inches.
11. Supports for Copper & Brass Pipes: All copper and brass pipe supports shall be specifically manufactured for use with copper & brass pipe. Hangers shall be provided with a copper finish.
12. Hangers for Radiators:
- a. Support wall hung radiators on approved wall brackets or overhead hangers.
  - b. Support wall hung radiators by all-metal brackets and plates that are screw adjustable after erection. Wall plates shall be made of stainless steel of size and shape to insure rigidity and strength and with a minimum resistance to expansion. Plates shall be fastened directly to walls, columns or pilasters with at least one ½-inch bolt, and with spacing of brackets not in excess of 42-inches.

- c. Where rod hangers are specified or shown supporting wall radiators, supporting rods shall be not less than 5/8-inch in diameter.

13. Concrete Supports:

- a. Where pipeline or mechanical equipment is shown, specified or required to be supported on concrete supports, supports shall be as specified herein.
- b. Concrete supports for equipment shall be of a size and mass that will resist all forces, both static and dynamic, which may be developed by the equipment.
- c. Concrete supports for pipe, fittings, valves and appurtenances shall be designed to carry the weight of the pipeline and appurtenances. Cradles and anchor blocks shall safely withstand all stresses imposed by the pipelines, under all operating conditions. Concrete cradles shall be shaped to fit the contour of the pipe.
- d. Concrete supports shall be anchored to the floor of main structures by doweling or other approved means. Anchor bolts, extension plates, saddle yokes and other hold-down devices in concrete bases shall be placed before pouring of concrete. Expansion bolts shall not be used on new concrete supports except with the specific approval of the Engineer.
- e. Concrete supports shall be not less than Class 25 as specified in Section 03300 - Cast-in-Place Concrete.

2.04 ACCESSORIES

A. Hanger Rods:

- 1. Material shall be Type 316 stainless steel. Maximum allowable working stress shall be 5,800 psi, calculated based on the root diameter.
- 2. Rods shall have a square head nut on top and running thread on bottom end.
- 3. Hanger rods for single pipe hangers shall be sized in accordance with the following schedule:

**GENERAL SPECIFICATION 15060 – HANGERS AND SUPPORTS**

---

<b>Hanger Rod Diameter (Minimum)</b>			
<b>Pipe Size (inches)</b>	<b>Single Rod (inches)</b>	<b>Double Rod (inches)</b>	<b>Maximum Load Per Hanger (lbs)</b>
3/4 to 1-1/2, incl	3/8	3/8	300
2	3/8	3/8	325
2-1/2	1/2	3/8	350
3	1/2	3/8	400
3-1/2	1/2	3/8	450
4	5/8	1/2	850
5	5/8	1/2	950
6	3/4	5/8	1075
8	*7/8	5/8	1350
10	*7/8	5/8	1750
12	*7/8	3/4	2200
14	*1	7/8	2500
16	*1	7/8	3075
18	*1	7/8	3700
20	*1-1/4	1	4425
24	*1-1/4	1	6050

\* To be used subject to the Engineer's specific approval

a. Hanger loads shall be calculated based on the weight of pipe filled with water plus 50 pounds per foot of dead load.

**B. Concrete Inserts, Attachment Plates and Clamps:**

1. Hanger rods up to 7/8-inch diameter shall be attached to new concrete structures using concrete inserts MSS SP-58, Type 18. Inserts shall be malleable iron with galvanized finish. The use of steel inserts is prohibited. Design of the inserts shall permit the rods to be adjusted laterally in one plane and to lock the rod nut or head to the body. The inserts shall be provided with openings or recesses to receive reinforcing rods. To facilitate installation, slots shall be provided in the exposed

flanges of the insert. Inserts shall be rated to safely carry the maximum load which can be supported by the hanger rod.

2. Hanger rods larger than 7/8-inch diameter shall be attached to new concrete by means of approved hook anchors as shown on the Contract Drawings.
3. Hanger rods shall be attached to existing concrete structures using stainless steel expansion anchors as specified in Section 05501 - Metal Fabrications.
4. Steel beam clamps shall be malleable iron and conform to MSS SP-58 Type 28 or 29 for wide flange or I-beams, and Type 20 for channel sections or where it is necessary to locate the hanger rod off the beam centerline.
5. Steel U-shape beam attachments welded to the underside of beams, and welded steel brackets fastened to structural steel columns, shall be subject to specific approval of the Structural Steel and Pipe Supports Shop Drawings.

#### 2.05 PIPE INSULATION PROTECTION

- A. Contractor shall furnish steel protection saddles on all supports for insulated pipe.
  1. For pipe sizes less than 12 inches in diameter, provide saddles of No. 14 U.S. gauge stainless steel curved 180 degrees for use with roller hangers or structural trapeze hangers and of No. 16 U.S. gauge stainless steel curved 120 degrees for use in clevis hangers. Saddles shall be at least 12-inches long. Saddle gripping side edges shall be turned up at least to the thickness of insulation.
  2. For pipe 12 inches in diameter and larger, provide saddles of No. 12 U.S. gauge stainless steel with a welded centerplate to provide three-edge support. Saddles shall be at least as long as the pipe diameter, provide 120 degree coverage and have edge and centerplate depths equal to the insulation thickness.
- B. Before placing the saddles, saddles shall be filled with either insulating cement or high density insulation cut to fit. For vapor barrier insulation, the barrier must be maintained; contact between hanger and support and bare pipe will not be permitted.

#### 2.06 PIPE ANCHORS AND BRACES

- A. Anchors and sway braces shall be provided when required to hold the pipelines and equipment in position or alignment. Pipe anchors and braces for rigid fastening to the structures shall be attached to stainless steel anchor plates and anchor bolts set into the forms when placing concrete of new structures.

Brackets and braces shall be attached to existing concrete structures with through bolts or expansion anchors.

- B. Anchors, guides and restraints shall be provided for the proper operation of pipeline expansion joints.
- C. Cast iron anchors shall be provided with stainless steel straps on piping, except where anchors form an integral part of pipe fittings and couplings or where an anchor of special design is required or shown on the Contract Drawings.
- D. All pipe anchors, guides and restraints shall be designed to conform to ASME B31.1.

#### 2.07 INSPECTION

- A. The City may elect to conduct shop inspections. The inspections may include but not be limited to: mechanical and chemical testing, material sampling, material certifications, traceability of parts, blasting and painting, visual and dimensional inspection, and free iron contamination check on stainless steel parts.

#### 2.08 GALVANIZING

- A. Galvanizing shall conform to Section 05081 - Galvanizing, except that malleable iron and concrete inserts shall be galvanized in conformance with the manufacturer's specifications.

### PART 3 EXECUTION

#### 3.01 GENERAL

- A. Hangers, supports, and accessories shall be located within maximum span lengths specified to support continuous pipeline runs unaffected by concentrated loadings.
- B. Hangers or supports shall be provided at all locations where piping changes direction.
- C. Hangers and supports shall be located to prevent vibration or swaying and to provide for expansion and contraction.
- D. Hangers' rods shall be straight and vertical. Chain, wire, strap or perforated bar hangers shall not be used. Hangers shall not be suspended from piping.
- E. Concrete embedded items shall be installed before concrete placement.
- F. Embedded items shall be fastened securely to prevent movement during concrete placement.
- G. Hanger and support units installation methods shall be in accordance with manufacturer's recommendations.



- H. Hangers and supports shall be adjusted and grout placed as specified in Section 03600 – Grout to bring pipelines to specified elevations.

3.02 SPACING OF HANGERS AND SUPPORTS

A. Supports and Hangers for Horizontal Pipes:

- 1. Supports and hangers for all piping shall be placed no farther apart than shown below, unless otherwise shown or specified:
  - a. Ductile Iron, Steel and Stainless Steel Pipe:
    - 1) Maximum spacing in accordance with Table 3 of MSS-SP-69. The designer should check the capacity of the steel or building structure to which the hanger or support is attached, and adjust the maximum spacing accordingly.
    - 2) In addition, ductile iron pipe shall have a minimum of two supports per length and shall have a hanger or support adjacent to each end.
  - b. Thermoplastic Pipe:
    - 1) Pipes up to 1-inch: 2 feet-6 inches center to center.
    - 2) Pipes 1-1/2-inch to 3-inch: 4 feet-0 inches center to center.
    - 3) Pipe 4-inch to 8-inch: 6 feet-0 inches center to center.
    - 4) Pipes larger than 8-inch: 8 feet-0 inches center to center.
  - c. Cast Iron Soil Pipe: 5 feet-0 inches.
  - d. Tubing less than 1-inch diameter: In accordance with best piping practice and ASME B31.1, and as approved by the Engineer.
- 2. Additional supports shall be placed immediately adjacent to any change in piping direction, at equipment, and on both sides of valves, expansion joints and couplings.

B. Supports for Vertical Piping:

- 1. Riser clamp shall be placed under hub, fitting or coupling with approved solid bearing on steel sleeve.
- 2. Where riser clamps are used with plastic piping they shall be modified so as not to exert any compressive forces on the pipe.
- 3. Vertical piping shall be supported at each floor and between floors by stays or braces to prevent rattling and vibration. Maximum spacing shall not exceed 25 feet.

## GENERAL SPECIFICATION 15060 – HANGERS AND SUPPORTS

---

4. Base elbows or welded equivalent shall be provided at vertical piping bases.
  5. Top support shall have a horizontal connection, and provide for pipe expansion.
- C. Pipelines installed under plumbing work shall be spaced in conformity with the requirements of the New York City Building Code or as specified herein.
- 3.03 PAINTING AND COATING
- A. Painting shall be in conformity with Section 09900 - Painting.
  - B. Surfaces of hangers and supports in contact with aluminum, brass, plastic and copper pipelines or pipeline equipment shall be protected with an approved plastic coating to prevent abrasion. Touch-up shall be provided in the field, as required. Coating shall be applied in accordance with the manufacturer's recommendations, and shall be free from spots and brush marks, to the satisfaction of the Engineer.
- 3.04 TESTING
- A. All pipe support and restraining systems shall be installed and secured prior to the testing or activation of the pipeline on which they are installed.
  - B. All pipe support systems shall be tested for compliance with the Contract Documents. After installation, each pipe support system shall be tested in conjunction with the respective piping pressure tests. Tests shall include cycling the piping system to duplicate operating conditions. If any part of the pipe support system proves to be defective or inadequate, as evidenced by vibration or excessive movement, it shall be repaired or augmented at no additional cost to the City.

END OF SECTION

**SECTION 15071  
Vibration Control**

**PART 1 GENERAL**

**1.01 SECTION INCLUDES**

- A. The Contractor shall provide all labor, materials, equipment and incidentals as shown, specified and required to furnish and install all vibration control devices complete with auxiliary equipment and accessories for proper operation.
  - 1. Vibration control shall be achieved by use of approved vibration eliminators installed as directed by the manufacturer of the eliminators.
  - 2. All Work shall conform to the applicable requirements of ASHRAE, OSHA & AMCA for limitations of sound and vibration levels. All Work shall operate under all conditions of load without objectionable sound or vibration.
- B. The following index of this Section is presented for convenience:

<u>Article</u>	<u>Title</u>	<u>Page</u>
		15071-
PART 1	GENERAL .....	1
1.01	Section Includes .....	1
1.02	Payment.....	2
1.03	References.....	2
1.04	Submittals .....	2
1.05	Quality Assurance.....	2
PART 2	PRODUCTS.....	3
2.01	Manufacturers .....	3
2.02	Spring Hangers.....	3
2.03	Housed (Restrained) Spring Mountings.....	4
2.04	Rubber Mats.....	4
2.05	Double Deflection Rubber Mounting .....	4
2.06	Horizontal Thrust Restraints .....	5
2.07	Flexible Connectors .....	5
2.08	Vertical Riser Pipe Anchors.....	6
2.09	Pipe Isolation .....	6
PART 3	EXECUTION.....	6
3.01	Inspection.....	6
3.02	Installation.....	6
3.03	Cleaning .....	6
3.04	Schedules .....	6

## GENERAL SPECIFICATION 15071 – VIBRATION CONTROL

---

### 1.02 PAYMENT

- A. Payment for work furnished and installed under this Section shall be as specified in the Contract Documents.

### 1.03 REFERENCES

- A. Reference Standards: Comply with applicable provisions and recommendations of the following except as shown or specified:
  1. ASHRAE (American Society of Heating, Refrigeration and Air Conditioning Engineers, Inc.), Systems Volume, Latest Edition.
  2. OSHA - Occupational Safety and Health Administration
  3. AMCA – Air Movement and Control Association

### 1.04 SUBMITTALS

- A. Contractor shall submit Shop Drawings and material specifications for the approval of the Engineer. Submittals shall include, but not be limited, to:
  1. Manufacturer's literature, illustrations, Specification and engineering data showing the following:
    - a. Isolation mounting deflections.
    - b. Spring diameters.
    - c. Compressed spring height at rated load.
    - d. Solid spring height.
    - e. Equipment operating speed.
    - f. Tabulated data for equipment weights and vibration eliminator capacities.
  2. Other technical data related to the specified equipment.
- B. Operation and Maintenance Manuals:
  1. Submit complete installation, operation and maintenance manuals including copies of all Shop Drawings, test reports, maintenance data and schedules, description of operation, and spare parts information.
  2. Furnish operation and maintenance manuals in conformance with the requirements of the Contract Documents.

### 1.05 QUALITY ASSURANCE

- A. Design Criteria:
  1. Vibration isolators shall be selected for uniform static deflections according to distribution of weight.

2. Selections shall be based on lowest rotational speed as disturbing frequency.
  3. Total rated capacity of isolators shall be at least 110 percent of the weight of equipment supported. Contractor to verify the actual weight of the equipment to be supported.
  4. Housings, fabricated steel parts, hangers, rods, supports, bolts, nuts, washers, inserts, and appurtenances as required to provide a complete vibration isolation system as described below and shall be Type 316 stainless steel construction.
- B. Manufacturer Qualifications:
1. Engage a single firm, with undivided responsibility for performance, fabrication, and other requirements.
  2. The equipment referenced by this Section is intended to be standard equipment of proven performance as manufactured by reputable concerns. Equipment shall be designed, constructed and installed in accordance with the best practices of the trade, and shall operate satisfactorily when installed as shown on the Contract Drawings.
- C. Contractor's Qualifications:
1. Contractor shall have at least 5 years' experience in the installation of the Work specified. He shall employ only tradesmen with specific skills and experience in this type of Work.
  2. Contractor shall have undivided responsibility as a single firm for performance and other requirements for the installation of the Work specified herein.

## PART 2 PRODUCTS

### 2.01 MANUFACTURERS

- A. Provide isolation equipment as manufactured by:
1. Mason Industries, Hauppauge, NY.
  2. Vibration Eliminator Company, Copiague, NY.
  3. Or approved equal.

### 2.02 SPRING HANGERS

- A. Type: Spring isolators, laterally unrestrained.
- B. Efficiency: 95 percent at rated load.
- C. Construction:

1. Designed so that ratio of horizontal to vertical spring constants is between one and two.
2. Spring with 0.3 inch deflection EPDM element.
3. EPDM element shall have rod isolation bushing.
4. Hanger shall permit rod to swing through 30 degree arc before contacting metal.
5. Spring shall have additional travel to solid of 50 percent of rated deflection.

2.03 HOUSED (RESTRAINED) SPRING MOUNTINGS

- A. Type: Spring isolator, free standing, laterally stable with housing.
- B. Efficiency: 95 percent at rated load.
- C. Construction:
  1. Housing: Shall include vertical limit stops.
  2. Clearance: Maintain ½-inch clearance around restraining bolts and between housing and spring.
  3. Weatherproofing: Type 316 stainless steel housing cover for outdoor use.
  4. Baseplate with 1/4-inch acoustical friction pad between baseplate and support.
  5. Leveling bolts rigidly bolted to the equipment.
  6. Spring diameter 0.8 of the compressed spring height at rated load.
  7. Minimum spring deflection before becoming solid shall be at least 50 percent greater than the specified minimum deflection.

2.04 RUBBER MATS

- A. Type: EPDM waffle mat.
- B. Construction: Two 5/16-inch thick EPDM layers with a 16 gauge Type 316 stainless steel plate cemented between layers.

2.05 DOUBLE DEFLECTION RUBBER MOUNTING

- A. Double deflection neoprene mountings shall have a minimum static deflection of 0.35". All metal surfaces shall be neoprene covered to avoid corrosion and have friction pads both top and bottom so they need not be bolted to the floor. Bolt holes shall be provided for these areas where bolting is required. On equipment such as small vent sets and close coupled pumps, steel rails shall be used above the mountings to compensate for the overhang. Mountings shall be type ND or rails type DNR as manufactured by:

1. Mason Industries, Inc., Hauppauge, NY.
2. Or approved equal.

2.06 HORIZONTAL THRUST RESTRAINTS

- A. Air handling equipment shall be protected against excessive displacement which might result from high air thrusts in relation to the equipment weight. The horizontal thrust restraint shall consist of a spring element in series with a neoprene pad with the same deflection as specified for the mountings or hangers. The spring element shall be contained within a steel frame and designed so it can be preset for thrust at the factory and adjusted in the field to allow for a maximum of 1/4-inch movement at start and stop. The assembly shall be furnished with one rod and angle brackets for attachment to both the equipment and ductwork or the equipment and the structure. Horizontal restraints shall be attached at the centerline of thrust and symmetrically on either side of the unit. Horizontal thrust restraints shall be WB as manufactured by:
1. Mason Industries, Inc., Hauppauge, NY.
  2. Or approved equal.

2.07 FLEXIBLE CONNECTORS

- A. Flexible Neoprene Connectors (for ductwork connected to equipment with motors):
1. Flexible neoprene connectors shall be manufactured of multiple plies of nylon tire cord fabric and neoprene both molded and cured in hydraulic rubber presses. No steel wire or rings shall be used as pressure reinforcement. Straight connectors shall have two spheres. Connectors up to and including 1-1/2" diameter may have threaded ends. Connectors 2" and larger shall be manufactured with floating type 316 stainless steel flanges recessed to lock the connector's raised face neoprene flanges. Hoses shall be installed on the equipment side of the shut-off valves.
  2. Connectors shall be rated a minimum of 150 psi at 220 F. Flanged equipment shall be directly connected to neoprene elbows in the size range 2-1/2" through 12" if the piping makes at 90 turn at the equipment. All straight through connections shall be made with twin-spheres properly pre-extended as recommended by the manufacturer to prevent additional elongation under pressure. 12" and larger sizes operating above 100 psi shall employ control cables with end fittings isolated by means of 1/2" thick bridge bearing neoprene washer bushings designed for a maximum of 1000 psi.

3. Elbows shall be Mason-Flex type MFNEC, straight connectors Mason-Flex type MFTFU or MFTNC, and control cable assemblies type ACC, all as manufactured by:
  - a. Mason, Industries, Inc., Hauppauge, NY.
  - b. Or approved equal.

B. Flexible Connectors at Pumps: Flexible connectors at base mounted hot and chilled water pumps shall consist of a stainless steel bellows assembly complete with flanged carbon steel fittings, heavy duty restraining rods and spacers. The connector shall be suitable for use with water at 250 F and 125 psi. Flexible connectors at pumps shall be as manufactured by flexonics products of Bartlett, IL, or approved equal.

#### 2.08 VERTICAL RISER PIPE ANCHORS

- A. Provide an all directional acoustical pipe anchor, consisting of a telescopic arrangement of two sizes of steel tubing separated by a minimum half inch thickness of heavy duty neoprene and duck or neoprene isolation material. Vertical restraints shall be provided by similar material arranged to prevent vertical travel in either direction. Allowable loads on the isolation material shall not exceed 500 psi and the design shall be balanced for equal resistance in any direction. All-directional anchors shall be type ADA as manufactured by:
  1. Mason Industries, Inc., Hauppauge, NY.
  2. Or approved equal.

#### 2.09 PIPE ISOLATION

- A. Horizontal Pipe Isolation: The first three pipe hangers on each side in the main lines near the mechanical equipment shall be spring hangers. Floor supported piping shall rest on isolators with house spring mountings. Hangers shall be located as close to the overhead supports as practical.
- B. Riser Isolation: Risers shall be suspended from or supported by spring hangers or housed spring mountings and the piping anchored or guided with pipe anchors. Type 316 stainless steel. Spring piping deflections shall be a minimum of 0.75" except in those expansion locations where additional deflection is required to limit deflection or load changes to plus or minus 25% of the initial stress.

### PART 3 EXECUTION

#### 3.01 INSPECTION

- A. Inspect anchor bolts for proper locations.

#### 3.02 INSTALLATION

- A. Install as per manufacturer's recommendations.



## GENERAL SPECIFICATION 15071 – VIBRATION CONTROL

---

### 3.03 CLEANING

- A. Remove foreign objects which might bridge vibration isolators.

### 3.04 SCHEDULES

- A. Use types of isolators for equipment specified below unless otherwise specified.

<b>Equipment</b>	<b>Type</b>
Central station air handling (heating and ventilation) units, and central station rooftop air handling units.	Internally mounted housed spring mountings for fans and motors (factory installed by unit manufacturer).
Air cooled condensers, chillers, fluid coolers, control room air conditioning units, air filtration units.	Rubber mats.
Unit heaters, centrifugal inline fans, or other suspended equipment with fans and/or motors.	Spring hangers
Base mounted Centrifugal fans, pumps.	Housed spring isolators

END OF SECTION

NO TEXT ON THIS PAGE

**GENERAL SPECIFICATION 15076 – PIPING AND EQUIPMENT  
IDENTIFICATION**

---

**SECTION 15076  
Piping and Equipment Identification**

**PART 1 GENERAL**

**1.01 SECTION INCLUDES**

- A. Furnish and install all components of the system for identification of piping and equipment. The system includes the placing of identification signs and direction-of-flow arrows on all visible plant piping, the placing of nameplates on plant equipment and structures, and painting in color of all equipment and pipe, except stainless steel or aluminum surfaces, as shown on the Contractor's Shop Drawings submitted under the related Sections for equipment, piping and valves, and as required for a complete job.
- B. The following index of this Section is included for convenience:

<u>Article</u>	<u>Title</u>	<u>Page</u>
		15076-
PART 1	GENERAL .....	1
1.01	Section Includes .....	1
1.02	Related Section .....	2
1.03	Payment.....	2
1.04	References.....	2
1.05	Manufacturer's Guarantee .....	2
1.06	Spare Parts And Accessories .....	2
PART 2	PRODUCTS.....	3
2.01	Materials .....	3
2.02	Dimensions Of Signs And Tags.....	3
2.03	Lettering Of Signs.....	4
2.04	Chemical Resistance .....	4
2.05	Colors .....	5
2.06	Legend For Pipe Identification Signs .....	7
2.07	Valve Identification Tags.....	11
2.08	Arrows.....	12
2.09	Nameplates.....	12
2.10	Additional Signs And Nameplates.....	18
2.11	Color Of Pipelines.....	19
PART 3	EXECUTION.....	24
3.01	Location .....	24
3.02	Mounting.....	24

**GENERAL SPECIFICATION 15076 – PIPING AND EQUIPMENT  
IDENTIFICATION**

---

1.02 RELATED SECTION

- A. Section 09900 - Painting

1.03 PAYMENT

- A. No direct payment will be made for these signs, flow charts or appurtenances; the cost must be included in the price bid for the piping system as specified in the Contract Documents.

1.04 REFERENCES

- A. The following standards are referenced in this Section:

1. ASTM D523 - Standard Test Method for Specular Gloss
2. ASTM D543 - Standard Practices for Evaluating the Resistance of Plastics to Chemical Reagents
3. ASTM D638 - Standard Test Method for Tensile Properties of Plastics
4. ASTM D646 - Standard Test Method for Grammage of Paper and Paperboard (Mass per Unit Area)
5. ASTM D709 - Standard Specification for Laminated Thermosetting Materials
6. ASTM D790 - Standard Test Methods for Flexural Properties of Unreinforced and Reinforced Plastics and Electrical Insulating Materials
7. ASTM D792 - Standard Test Methods for Density and Specific Gravity (Relative Density) of Plastics by Displacement
8. ASTM D5420 - Standard Test Method for Impact Resistance of Flat, Rigid Plastic Specimen by Means of a Striker Impacted by a Falling Weight (Gardner Impact)
9. Federal Standard 595B Colors description

1.05 MANUFACTURER'S GUARANTEE

- A. Provide the specified items from firms regularly engaged in the manufacture of identification devices of types and sizes required, with at least five (5) years' experience in manufacturing signs. In addition, the manufacturer shall

**GENERAL SPECIFICATION 15076 – PIPING AND EQUIPMENT  
IDENTIFICATION**

---

guarantee the sign, in writing, against color fading, chipping, corroding or any other manufacturing defects for a period of ten (10) years.

1.06 SPARE PARTS AND ACCESSORIES

- A. Furnish the following spare parts and accessories:
1. For every 20 pipe identification signs installed:
    - a. One pair stainless steel mounting screws
    - b. One pair stainless steel threaded brackets
    - c. One pair fiber or plastic washers
    - d. One pair stainless steel banding seals
  2. One set banding tools and banding accessories
  3. One stainless steel banding strap, approximately 1000 ft.
  4. One complete nameplate mounting assembly for every 20 nameplates installed
  5. One stainless steel cable and splice for every 20 valve identification tags
- B. Provide all spare parts and accessories suitably boxed and marked for storage and reordering.

PART 2 PRODUCTS

2.01 MATERIALS

- A. Construct fiberglass reinforced plastic identification signs and nameplates of 70 mils thick fiberglass reinforced plastic conforming to ASTM D709.
- B. Provide fiberglass reinforced plastic process with a blemish free, low gloss surface of superior permanence and durability in the colors selected. Provide each identification sign and nameplate in two colors and with the legend specified. Provide the backside of the sign in black or some other uniform color.
- C. Provide lettering made by silk screening or other permanent embedment of subsurface printed graphics in the material so as to produce a clear, legible sign. Do not place lettering, symbols or markings containing the name of the manufacturer on the signs. The contract number and the year of the contract as given on the Contract Drawings may be placed in small lettering on the front of the sign, if approved by the Engineer.
- D. Provide signs for piping and valve identification with two 3/8 inch diameter grommet-protected holes located on the long side center line, the center of the hole to be 1/2 inch from the edge. Provide nameplates for equipment and structures with four 3/8 inch diameter grommet-protected holes, the center of

**GENERAL SPECIFICATION 15076 – PIPING AND EQUIPMENT IDENTIFICATION**

---

the hole located ½ inch away from the edges. Provide all holes with suitable brass or stainless steel grommets.

- E. Construct all signs and nameplates in conformity with ASTM D523, D638, D646, D790, D792 and D5420.

2.02 DIMENSIONS OF SIGNS AND TAGS

- A. Provide identification signs and nameplates rectangular in shape and of the dimensions specified below. A dimensioned tolerance of plus or minus 1/16 inch is permissible.

TYPE OF SIGN	Sign Dimensions (Width x Length)
PIPE IDENTIFICATION - 1. Outside diameter of pipe (including pipe insulation): a. 4 inches and larger b. less than 4 inches	3-1/2 x 12 inches  1-1/2 x 7 inches
VALVE IDENTIFICATION - 1. Valve tags 2. Operating stands for valves and sluice gates	2 inches diameter  1-1/2 x 7 inches
NAMEPLATES - 1. Equipment and structures	3-1/2 x 12 inches

2.03 LETTERING OF SIGNS

- A. Perform all lettering and numbering on identification signs and nameplates in block style in size and spacing to suit the size of sign, as approved by the Engineer.
- B. Unless otherwise approved, limit the legend on pipe identification signs to one line and to a total of 12 letters and spaces, and the legend on equipment nameplates to two lines and a maximum of 35 letters and spaces.
- C. Submit samples of the lettering to be used for fiberglass reinforced plastic signs to the Engineer for approval before manufacturing begins. Such samples must show the height, width and spacing of letters and numbers for any three (3) legends of ten or more letters and spaces as listed in Article 2.06.

**GENERAL SPECIFICATION 15076 – PIPING AND EQUIPMENT IDENTIFICATION**

---

2.04 CHEMICAL RESISTANCE

- A. Provide fiberglass reinforced plastic signs resistant to abrasion, impact, corrosion, and the following acids, alkalis, salts and solvents in accordance with ASTM D543:
1. 10% citric acid
  2. 5% acetic acid
  3. 3-30% sulfuric acid
  4. 10% ammonium hydroxide
  5. 10% sodium chloride
  6. turpentine
  7. mineral spirits
  8. heptane
  9. kerosene
  10. ethyl alcohol
  11. ethyl acetate
  12. transformer oil
  13. heavy duty detergents
  14. water
- B. Submit certification on acid resistance to the Engineer prior to installation.

2.05 COLORS

- A. Code pipeline signs and equipment nameplates and finish coats of paint for pipe lines and equipment in basic colors.
- B. Provide brilliant colors, distinctive shades matching as closely as possible (without custom color blending) the following basic colors as specified by the Munsell Color System (MN):

<b>Table Of Standard Colors</b>	
<b>Color</b>	<b>Munsell Number</b>
White	MN - N8.8/
Yellow	MN - 4Y7.5/12.8
Orange	MN - 0.5 YR 4.6/12.2
Red	MN - 7R 3.6/12.7

**GENERAL SPECIFICATION 15076 – PIPING AND EQUIPMENT  
IDENTIFICATION**

<b>Table Of Standard Colors</b>	
<b>Color</b>	<b>Munsell Number</b>
Brown	MN - 2.5 YR 4.2/4.3
Gray	MN - 2.5PB 5.8/1.7
*Charcoal	MN - 6B 5/0.4
Black	MN - N1/
Blue	MN - 3PB 3.3/7.4
Green	MN - 8G 4.4/6.2
* Provide color "Charcoal" for paints equivalent to MN - N 3.75.	

- C. Provide identification signs for pipelines of all sizes, mechanical equipment, sluice gates and valves in the color combinations specified below under "General Color Code".

<b>General Color Code</b>		
<b>Service Line</b>	<b>Colors</b>	
	<b>Letters</b>	<b>Background</b>
1. FIRE AND STANDPIPE	White	Red
2. SLUDGE OR UTILITY GAS		
a. High Pressure	Black	Orange
b. Low Pressure	White	Orange
3. FUEL OIL	Orange	White
4. LUBRICATING OIL	Black	White
5. HYDRAULIC FLUID	Red	White
6. CHEMICALS		
a. Hazardous	Black	Yellow
b. Relatively Safe	Brown	Yellow
7. OZONE	Black	Yellow
8. CHLORINE		
a. Gas	Black	Yellow
b. Liquified	Red	Yellow
c. Solution	Blue	Yellow
9. LIQUIDS THICK IN SOLIDS		
a. Primary Sludge	White	Black
b. Digested Sludge		
c. Thickened Sludge		
10. LIQUIDS THINNER IN SOLIDS		
a. Secondary Sludge	White	Brown
b. Return Sludge		



**GENERAL SPECIFICATION 15076 – PIPING AND EQUIPMENT IDENTIFICATION**

---

<b>General Color Code</b>		
<b>Service Line</b>	<b>Colors</b>	
	<b>Letters</b>	<b>Background</b>
c. Mixed Liquor d. Grease, Scum, Grit		
11. LIQUIDS WEAK IN SOLIDS a. Sewage b. Effluent c. Thickening Tank Drains, Vents, Overflow d. Digester Tank Drains, Vents, Overflow e. Concentration Tank Drains, Vents, Overflow f. Storage Tank Overflow, Drains g. Settling Tank Overflow, Drains h. Sump Drains	Black	Gray
12. STRAINED EFFLUENT a. Spray Water b. Flushing Water	Yellow	Gray
c. Plant Water		
13. NON-POTABLE WATER a. Seal Water b. Chilled Water c. Engine Cooling Water d. Sludge Heating Water e. Hydraulic Control Water	Yellow	Blue
14. CITY WATER	White	Blue
15. STEAM, DANGEROUSLY HOT WATER	Blue	Orange
16. ENGINE AIR a. Starting b. Intake	Orange Yellow	Green Green
17. ENGINE EXHAUST	Yellow	Orange
18. VACUUM SERVICE	Black	Green
19. PLANT SERVICE (COMPRESSED) AIR	White	Green
20. PROCESS (BLOWER) AIR	Gray	Green
21. HIGH PRESSURE AIR	Orange	Green

**GENERAL SPECIFICATION 15076 – PIPING AND EQUIPMENT IDENTIFICATION**

---

<b>General Color Code</b>		
<b>Service Line</b>	<b>Colors</b>	
	<b>Letters</b>	<b>Background</b>
22. HEATING, VENTILATING AND CONDITIONING AIR (Equipment And Ductwork)	Green	Charcoal

- D. Provide vents and drains of the same color combination as the contents of tanks and equipment vented and drained.
- E. Identification signs for miscellaneous services not included in the General Color Code shall be black letters on a white background.

2.06 LEGEND FOR PIPE IDENTIFICATION SIGNS

- A. Provide identification signs with the following words or abbreviations in color combinations shown to identify the pipe line service:

<b>Pipe Identification Signs</b>			
<b>LEGEND</b>	<b>Service</b>	<b>Color Code</b>	
		<b>Lettering</b>	<b>Background</b>
BLOWER LUBE	Blower lube oil	Black	White
BLOWOFF	Blowoff	*	*
CAUSTIC	Caustic soda	Black	Yellow
CHILL SUPPLY	Chilled water supply	Yellow	Blue
CHILL RETURN	Chilled water return	Yellow	Blue
CHLORINE GAS	Chlorine gas	Black	Yellow
CHLOR. LIQ.	Liquefied chlorine	Red	Yellow
CHLOR. SOL.	Chlorine solution	Blue	Yellow
COMP. AIR	Compressed or plant service air	White	Green
CONDENSATE	Condensate	Yellow	Blue

**GENERAL SPECIFICATION 15076 – PIPING AND EQUIPMENT IDENTIFICATION**

---

<b>Pipe Identification Signs</b>			
<b>LEGEND</b>	<b>Service</b>	<b>Color Code</b>	
		<b>Lettering</b>	<b>Background</b>
DEFOAMANT	Defoamant or foam control	Brown	Yellow
DIESEL FUEL	Diesel fuel oil	Orange	White
DIGEST. SL.	Digested sludge	White	Black
DIG. O'FLOW	Digester overflow	Black	Gray
DISINFECT	Disinfectant	Brown	Yellow
DRAIN - *	Drain - *	*	*
EFFLUENT	Effluent water	Black	Gray
ENGINE AIR	Engine air intake	Yellow	Green
ENG. EXHAUST	Engine exhaust	Yellow	Orange
ENGINE LUBE	Engine lube oil	Black	White
ENGINE VENT	Engine crankcase vent	Black	White
EXCESS SLUDGE	Excess sludge	White	Black
EXH. BLOWOFF	Exhaust silencer blowoff	Red	Blue
FIRE	Fire line	White	Red
FLUSH. WATER	Pump flushing water	Yellow	Gray
FLY ASH	Wet fly ash	White	Black
FUEL OIL	Fuel oil	Orange	White
FUEL FILL	Fuel oil fill	Orange	White
GAS – SLUDGE	Sludge gas	White	Orange
GAS – UTILITY	Utility gas	White	Orange

**GENERAL SPECIFICATION 15076 – PIPING AND EQUIPMENT  
IDENTIFICATION**

---

<b>Pipe Identification Signs</b>			
<b>LEGEND</b>	<b>Service</b>	<b>Color Code</b>	
		<b>Lettering</b>	<b>Background</b>
GAS – HP	Sludge or utility gas – high pressure	Black	Orange
GREASE	Grease	White	Brown
GRIT	Grit	White	Brown
HI PRESS. AIR	High pressure air	Orange	Green
H.W. RETURN	Hot water return	Blue	Orange
H.W. SUPPLY	Hot water supply	Blue	Orange
HYDRAULIC	Hydraulic fluid	Red	White
HYPOCHLORITE	Sodium hypochlorite	Blue	Yellow
INSTR. AIR	Instrument air	White	Green
JACKET WATER	Engine jacket water	Yellow	Blue
LUBE	Lubricating oil	Black	White
LUBE FILL	Lubricating oil fill	Black	White
METER - *	Metering - *	*	*
MIXED LIQUOR	Mixed liquor	White	Brown
MIXED SLUDGE	Mixed sludge	White	Brown
MODIFIED SL.	Modified sludge	White	Brown
O'FLOW - *	Overflow - *	*	*
OZONE	Ozone	Black	Yellow
PLANT DRAIN	Plant drain	Black	Gray
PLANT WATER	Plant water	Yellow	Gray

**GENERAL SPECIFICATION 15076 – PIPING AND EQUIPMENT  
IDENTIFICATION**

---

<b>Pipe Identification Signs</b>			
<b>LEGEND</b>	<b>Service</b>	<b>Color Code</b>	
		<b>Lettering</b>	<b>Background</b>
PRIMARY SL.	Primary sludge	White	Black
PROCESS AIR	Process or blower air	Gray	Green
RECIRC. SL.	Recirculated sludge	White	Brown
RETURN SL.	Return sludge	White	Brown
SCUM	Scum	White	Brown
SEAL WATER	Seal water	Yellow	Blue
SECOND. SL.	Secondary sludge	White	Brown
SEWAGE	Sewage	Black	Gray
SEW. SAMPLE	Sewage sampling	Black	Gray
SPRAY WATER	Spray water	Yellow	Gray
STARTING AIR	Starting air	Orange	Green
STEAM	Steam	Blue	Orange
SUMP - *	Sump pump line - *	*	*
SUPERNATANT	Supernatant	Black	Gray
THICK. DR.	Thickener drain	Black	Gray
THICK. EFF.	Thickener effluent	Black	Gray
THICK. SL.	Thickened sludge	White	Black
TREAT. WATER	Chemically treated boiler feed water	Brown	Yellow
VACUUM	Vacuum line	Black	Green
VENT - *	Vent - *	*	*

**GENERAL SPECIFICATION 15076 – PIPING AND EQUIPMENT IDENTIFICATION**

---

<b>Pipe Identification Signs</b>			
<b>LEGEND</b>	<b>Service</b>	<b>Color Code</b>	
		<b>Lettering</b>	<b>Background</b>
WASTE GAS	Waste gas	White	Orange
WASTE OIL	Waste lubricating oil	Black	White
WATER	City water	White	Blue
* Where shown, specified or required, the legend for blowoff, drain, metering, sump, vent and similar lines shall also include the equipment, structure or identification number to which the service applies.			

- B. Number sluice gates and valves in conformity with the Basic Code as specified by the Operation and Maintenance Manual for the plant; see Article 2.07. Perform color combinations for such lines and valves in the same color combinations as the medium serviced and as given in the "General Color Code" of Article 2.05.
- C. In addition to the identification requirements listed above, for all gas piping at pressures above ½ psig, show the maximum pressure level within the piping as required by Local Law 30.

**2.07 VALVE IDENTIFICATION TAGS**

- A. Furnish and attach valve identification tags on all valves and controls.
- B. Provide round fiberglass reinforced plastic discs tags, approximately 2 inches in diameter, made in conformity with the requirements of Article 2.01. Provide tags with one 1/8 inch grommet protected hole at the top for fastening to the valve body using 1/16 inch diameter cable and splices or pins as approved. Provide grommets, cable splices and pins of stainless steel or other approved corrosion resistant material.
- C. Provide numbering code for the identification tags in conformity with the Basic Code as specified by the Operation and Maintenance Manual for the plant. Assign identification numbers subject to the approval of the Engineer and in conformity with the entire piping and equipment identification system. Provide identification code for each valve and control without duplication. Provide lettering on identification tags not less than 5/16 inch high and limited to two lines. Silk-screen lettering in correct color combination; stenciled or painted numbers and lettering will not be accepted.
- D. In addition to the tagging requirements listed above, provide tags at all gas valves at pressures above ½ psig with the operating pressure within the valve shown as required by Local Law 30.

**GENERAL SPECIFICATION 15076 – PIPING AND EQUIPMENT  
IDENTIFICATION**

---

2.08      **ARROWS**

- A.      Make direction-of-flow arrows for attachment to pipe identification signs from No. 16 U.S. gauge Type 304 stainless steel, the full width of the sign. Make the arrow head with a tapered point, about 90 degrees at the apex, extending one half of the sign width from the sign edge and one half of the sign width extending under the sign. Finish all edges of the arrow. Make point with a radius of 1/4 inch for the 3-1/2 inch wide sign and a radius of 3/16 inch for the 1-1/2 inch wide sign. Punch detents on the arrows to prevent twisting of the point. Drill one hole in the arrow in alignment with the hole in the pipe identification sign so that both sign and arrow can be mounted with the same screw and bracket.
- B.      Submit sample direction-of-flow arrows for both sizes of pipe identification signs to the Engineer for approval before installation.

2.09      **NAMEPLATES**

- A.      Provide nameplates for equipment and structures in the same color combination as the medium they service. Legends for nameplates must follow the terminology shown. Provide numbering system as described in the Operation and Maintenance Manual.
- B.      The following is a representative list, not necessarily complete, of nameplate legends with appropriate color combinations to which the equipment identification number must be added:

<b>N A M E P L A T E S</b>			
<b>Legend</b>		<b>Color Code</b>	
<b>First Line <sup>(1)</sup></b>	<b>Second Line <sup>(2)</sup></b>	<b>Lettering</b>	<b>Background</b>
AIR BLOWER	**	White	Charcoal
AIR COMPRESSOR	**	White	Green
AIR HANDLING	UNIT **	White	Charcoal
AIR CONDITIONING	UNIT **	White	Charcoal
AUXILIARY ELECTRIC	GENERATOR **	Red	Green
AUXILIARY LUBE	OIL PUMP **	Black	White
BAR SCREEN	**	Black	Gray
BLOWER CONTROL	CABINET **	Gray	Green
BLOWER CONTROL AIR	RECEIVER **	White	Green

**GENERAL SPECIFICATION 15076 – PIPING AND EQUIPMENT  
IDENTIFICATION**

---

<b>N A M E P L A T E S</b>			
<b>Legend</b>		<b>Color Code</b>	
<b>First Line <sup>(1)</sup></b>	<b>Second Line <sup>(2)</sup></b>	<b>Lettering</b>	<b>Background</b>
BLOWER LUBE OIL	AUX. PUMP **	Black	White
BLOWER LUBE OIL	COOLER **	Black	White
BLOWER LUBE OIL	RESERVOIR **	Black	White
BLOWER SILENCER	**	Gray	Green
BULK LUBE OIL	STORAGE **	Black	White
BYPASS OIL FILTER	**	Black	White
CHILLERS	**	White	Blue
CLEAN LUBE OIL	TANK **	Black	White
CONCENTRATION TANK	**	White	Black
CONDENSATE PUMP	**	Yellow	Blue
CONDENSATE RECEIVER	**	Yellow	Blue
CONDENSER	WATER COOLED **	Yellow*	Blue*
CONDENSER	AIR COOLED **	Yellow*	Blue*
CONE VALVE AIR	RECEIVER **	White	Green
DESCALER	**	Yellow	Blue
DIESEL TANK	**	Orange	White
DIGESTION TANK	**	White	Black
DIRTY LUBE OIL	TANK **	Black	White
EFFLUENT-LUBE OIL	COOLER **	Yellow	Gray
EFFLUENT WATER	STRAINER **	Yellow	Gray
EFFLUENT WATER	PUMP **	Black	Gray



**GENERAL SPECIFICATION 15076 – PIPING AND EQUIPMENT  
IDENTIFICATION**

---

<b>N A M E P L A T E S</b>			
<b>Legend</b>		<b>Color Code</b>	
<b>First Line <sup>(1)</sup></b>	<b>Second Line <sup>(2)</sup></b>	<b>Lettering</b>	<b>Background</b>
EFFLUENT WATER	TANK **	Yellow	Gray
ENGINE GENERATOR	**	Red	Green
ENGINE J.W.	MAKEUP	Yellow	Blue
ENGINE LUBE OIL	PURIFIER **	Black	White
ENGINE LUBE OIL	TANK **	Black	White
ENGINE OIL SUMP	TANK **	Black	White
EXHAUST FAN	**	White	Charcoal
EXCESS SLUDGE	DISTRIB. BOX **	White	Black
EXHAUST STEAM	CONVERTER **	Blue	Orange
FAN COIL UNITS	**	Blue*	Orange*
FLUSHING WATER	PUMP **	Yellow	Gray
FUEL OIL	PUMP **	Orange	White
FUEL OIL TANK	NO. 2 OIL **	Orange	White
FUEL OIL TANK	NO. 4 OIL **	Orange	White
FUEL OIL TANK	NO. 6 OIL **	Orange	White
FULL FLOW OIL	FILTER **	Black	White
GAS BOOSTER	**	Black	Orange
GASOLINE TANK	**	Orange	White
GAS COMPRESSOR	**	Black	Orange
GAS RECEIVER	**	Black	Orange

**GENERAL SPECIFICATION 15076 – PIPING AND EQUIPMENT  
IDENTIFICATION**

---

<b>N A M E P L A T E S</b>			
<b>Legend</b>		<b>Color Code</b>	
<b>First Line <sup>(1)</sup></b>	<b>Second Line <sup>(2)</sup></b>	<b>Lettering</b>	<b>Background</b>
GAS SURGE TANK	**	White	Orange
HEAT EXCHANGER	OIL **	White	Orange
HEAT EXCHANGER	STEAM-WATER **	Blue	Orange
HEAT EXCHANGER	WATER-WATER **	Blue	Orange
HEAT RECOVERY	SILENCER **	Yellow	Orange
HEAT. & VENT.	UNIT **	White	Charcoal
HIGH PRESSURE AIR	COMPRESSOR **	Orange	Green
HIGH PRESSURE AIR	DRYER **	Orange	Green
HIGH PRESSURE AIR	RECEIVER	Orange	Green
HOT WATER BOILER	**	Blue	Orange
HOT WATER CONVERTER	DOMESTIC **	Blue	Orange
HOT WATER HEATER	ELECTRIC **	Blue	Orange
HOT WATER GENERATOR	DOMESTIC **	Blue	Orange
HYDRO-PNEUMATIC	TANK **	White	Blue
INLET SLUICE GATE	CYLINDER **	Red	White
JACKET WATER CIRC.	PUMP **	Yellow	Blue
JACKET WATER	COOLER **	Yellow	Blue
JACKET WATER ENG.	OIL COOLER **	Yellow	Blue
LUBE OIL	PURIFIER **	Black	White
LUBE OIL STORAGE	PUMP **	Black	White

**GENERAL SPECIFICATION 15076 – PIPING AND EQUIPMENT IDENTIFICATION**

---

<b>N A M E P L A T E S</b>			
<b>Legend</b>		<b>Color Code</b>	
<b>First Line <sup>(1)</sup></b>	<b>Second Line <sup>(2)</sup></b>	<b>Lettering</b>	<b>Background</b>
LUBE OIL STORAGE	TANK **	Black	White
LUBE OIL TRANSFER	PUMP **	Black	White
MIXED SLUDGE	PUMP **	White	Brown
OUTLET SLUICE GATE	CYLINDER **	Red	White
OZONATOR	**	Black	Yellow
PLANT AIR	AFTERCOOLER **	White	Green
PLANT AIR	COMPRESSOR **	White	Green
PLANT AIR	RECEIVER **	White	Green
PLANT WATER	MAKEUP **	Yellow	Gray
PLANT WATER	TANK **	Yellow	Gray
PLANT WATER	PUMP **	Yellow	Gray
PUMP – CHILLED WATER	**	White	Blue
PUMP – CONDENSER WATER	**	Yellow	Blue
PUMP – DOMESTIC	HOT WATER **	White	Blue
PUMP – FEED WATER	**	Yellow	Blue
PUMP – FIRE	**	White	Red
RETURN FAN	**	White	Charcoal
RETURN SLUDGE	PUMP **	White	Brown
SCUM PIT	**	White	Brown
SEAL WATER	PUMP **	Yellow	Blue

**GENERAL SPECIFICATION 15076 – PIPING AND EQUIPMENT  
IDENTIFICATION**

---

<b>N A M E P L A T E S</b>			
<b>Legend</b>		<b>Color Code</b>	
<b>First Line <sup>(1)</sup></b>	<b>Second Line <sup>(2)</sup></b>	<b>Lettering</b>	<b>Background</b>
SEWAGE EJECTOR	**	Black	Gray
SEWAGE FLOW	METER **	Black	Gray
SEWAGE PUMP	**	Black	Gray
SLUICE GATE CONT.	AIR CHAMBER **	White	Green
SLUICE GATE CONT.	AIR TANK **	White	Green
SLUICE GATE HYD.	FLUID PUMP **	Red	White
SLUDGE HEATER	**	White	Black
SLUDGE HEATING H.W.	CIRC. PUMP **	White	Orange
SLUDGE HEAT WATER	MAKEUP TANK **	Yellow	Blue
SLUDGE DOCK	PUMP **	White	Black
SLUDGE RECIRC.	PUMP **	White	Brown
SLUDGE STORAGE	TANK **	White	Black
SLUDGE TRANSFER	BOX **	White	Black
SLUDGE TRANSFER	PUMP **	White	Black
SPRAY WATER	PUMP **	Yellow	Gray
STANDBY GENERATOR	**	Red	Green
STARTING AIR	COMPRESSOR **	Orange	Green
STARTING AIR	TANK **	Orange	Green
STEAM BOILER	**	Blue	Orange
SUMP PUMP	**	Black	Gray

**GENERAL SPECIFICATION 15076 – PIPING AND EQUIPMENT IDENTIFICATION**

---

<b>N A M E P L A T E S</b>			
<b>Legend</b>		<b>Color Code</b>	
<b>First Line <sup>(1)</sup></b>	<b>Second Line <sup>(2)</sup></b>	<b>Lettering</b>	<b>Background</b>
SUMP PUMP – CONC.	TANK **	Black	Gray
SUMP PUMP – DIGEST.	TANK **	Black	Gray
SUMP PUMP – EFF.	VAULT **	Black	Gray
SUPPLY FAN	**	White	Charcoal
THICKENER	**	White	Black
TRASH RACK	**	Black	Gray
UNIT HEATER – STEAM	**	White*	Charcoal*
UNIT HEATER – WATER	**	White	Charcoal*
WASTE LUBE OIL	PUMP **	Black	White
WASTE LUBE OIL	TANK **	Black	White
WATER TREATMENT	PUMP **	Brown	Yellow
WATER TREATMENT	TANK **	Brown	Yellow
<sup>(1)</sup> Nominal limit of 18 letters, numerals and spaces. <sup>(2)</sup> Nominal limit of 17 letters, numerals and spaces. *Where equipment is mounted on roofs or where exposed to the public view, such as in lobby or office areas, the color will be selected by the Architect.  **The legend on these nameplates also includes the appropriate six-digit numeral and letter designation for such equipment and structures as specified by the Operation and Maintenance Manual.			

**2.10 ADDITIONAL SIGNS AND NAMEPLATES**

- A. In addition to the legends specified above, the Engineer may order the Contractor to furnish and install additional identification signs, arrows and nameplates at no additional cost to the City. Such additional signs may be requested near completion of the work and will be limited to no more than five (5) signs for each of the five types specified in Article 2.02. Conform legends and color combinations for additional signs to the requirements specified.

**GENERAL SPECIFICATION 15076 – PIPING AND EQUIPMENT  
IDENTIFICATION**

---

2.11 COLOR OF PIPELINES

- A. Paint all pipelines and equipment in conformity with the requirements of Section 09900 - Painting. Color code the color of the final coats of paint.
- B. Match the color of the final coats as closely as possible, without custom blending, to the colors presented in the following table. The colors in this table are identified by their Federal Standard 595B Colors identification number and shall match this standard. The names of the colors in this table are for convenience only.
- C. Do not paint aluminum or stainless steel ductwork or jackets on insulated pipelines. Should the Sections state that flanges, flexible couplings, valves and fittings for such jacketed lines not be covered, paint only the flanges, flexible couplings, valves and fittings in accordance with the piping color code.

<b>Pipeline Identification</b>		
<b>ABBR.</b>	<b>Process/Service Line</b>	<b>Fed. Std. 595B Color</b>
AD	Aerator Drain	Gray 16187
APLM	Anionic Polymer	Green 14090
BLW	Balance Water	Blue 15193
BLO	Blower Lube Oil	White 17925
CPLM	Cationic Polymer	Green 14090
CSTC	Caustic (Sodium Hydroxide)	Orange 22544
CEN	Centrate	Gray 16492
CF	Centrifuge Feed	Black 14036
CHA	Channel Air	Green 14260
CHWR	Chill Water Return	Blue 17877
CHWS	Chill Water Supply	Blue 15450
CHEFF	Chlorinated Effluent	Gray 17875
CW	City Water	Blue 15200
CLD	Clarifier Drain	Gray 16187
CLWR	Cold Water Return	Blue 15187
CLWS	Cold Water Supply	Blue 15125
CA	Compressed Air (Plant Air)	Green 14449

**GENERAL SPECIFICATION 15076 – PIPING AND EQUIPMENT  
IDENTIFICATION**

---

<b>Pipeline Identification</b>		
<b>ABBR.</b>	<b>Process/Service Line</b>	<b>Fed. Std. 595B Color</b>
CCSK	Concentrated Skimmings	Tan 17778
CSB	Concentrator Subnatant	Gray 16314
C	Condensate	Gray 16357
CTD	Contact Tank Drain	Gray 16187
DFM	Defoamant	Pink 11630
DGOF	Degrit Overflow	Gray 16250
DGS	Degrittied Primary Sludge	Olive 14257
DWS	Dewatered Sludge	Navy 15044
DF	Diesel Fuel	Mustard 13275
DSD	Digested Sludge Disposal	Brown-black 10032
RCD	Digested Sludge Recirculation (mixing)	(See Note 1)
DSR	Digested Sludge Recycle	Black 14084
DSS	Digested Sludge to Storage	Black 17038
DST	Digested Sludge Transfer	Gray 16081
DSK	Dilute Skimmings	Tan 16405
ELF	Elutriation Feed	Black 15042
ECWR	Engine Cooling Water Return	Gray 15526
ECWS	Engine Cooling Water Supply	Navy 15045
EXH	Engine Exhaust	Stainless Steel Jacket
ELO	Engine Lube Oil	White 17925
FECL	Ferric Chloride	Blue 15095
FEF	Final Effluent	Gray 16492
FRS	Fire and Standpipe	Red 11350
FW	Flushing Water	Blue 15090
FF	Fuel Fill	Tan 10266
FO	Fuel Oil	Brown 16160
	Gasoline Fill Port – high octane	Red 11086

**GENERAL SPECIFICATION 15076 – PIPING AND EQUIPMENT  
IDENTIFICATION**

---

<b>Pipeline Identification</b>		
<b>ABBR.</b>	<b>Process/Service Line</b>	<b>Fed. Std. 595B Color</b>
	Gasoline Fill Port – middle octane	Blue 15056
	Gasoline Fill Port – low octane	White 17925
	Gasoline Fill Port, unleaded – high octane	Red 11086 with white 17925 cross
	Gasoline Fill Port, unleaded – middle octane	Blue 15056 with white 17925 cross
	Gasoline Fill Port, unleaded – low octane	White 17925 with black 17038 cross
	Gasoline Vapor Recovery	Orange 12246
GRIT	Grit	Gray 14064
HPAR	High Pressure Air (Plant Air)	Green 14272
DG(H)	High Pressure Digester Gas	Orange 22510
HPUGS	High Pressure Utility Gas	Orange 22510
HWR	Hot Water Return (heating)	Orange 12215
HWS	Hot Water Supply (heating)	Orange 11400
HVACEX	HVAC Exhaust	Gray 14158
HVACR	HVAC Return	Gray 14077
HVACS	HVAC Supply	Gray 14056
HCW	Hydraulic Control Water	Blue 15107
HOR	Hydraulic Oil Return	Brown 10059
HOS	Hydraulic Oil Supply	Brown 10045
ITK	Intake (Engine Air)	Green 14672
JKWR	Jacket Water Return	Gray 15109
JKWS	Jacket Water Supply	Navy 15050
	Kerosene Fill Port	Brown 20100
LM	Lime	Tan 13740
DG(L)	Low Pressure Digester Gas	Orange 22510
LPUGS	Low Pressure Utility Gas	Orange 22510
LF	Lube Fill	White 17925



**GENERAL SPECIFICATION 15076 – PIPING AND EQUIPMENT  
IDENTIFICATION**

---

<b>Pipeline Identification</b>		
<b>ABBR.</b>	<b>Process/Service Line</b>	<b>Fed. Std. 595B Color</b>
MH	Methanol	Brown 10233
MS	Mixed Sludge (heating)	(See Note 1)
ODCDW	Odor Control Draw	Green 14110
ODCVT	Odor Control Vent	Unpainted
O2	Oxygen	Red 11105
OZR	Ozone Recycle	Blue 15177
OZS	Ozone Supply	Blue 15080
OZVT	Ozone Vent	Blue 15180
PD	Plant Drain	Gray 16187
PW	Plant Water	Blue 15092
PTPM	Potassium Permanganate	Red 11140
PEFF	Primary Effluent	Gray 16251
PA	Process Air	Green 14115
RINF	Raw Influent	Gray 16293
RPS	Raw Primary Sludge	Olive 14151
RSC	Raw Screenings	Tan 16350
RAS	Return Activated Sludge	Tan 10260
SMP	Sampling Line	Depends on service
SLW	Seal Water	Blue 15182
SBP	Secondary Bypass	Gray 16473
SAR	Service Air (Plant Air)	Green 14193
SW	Service Water	Blue 15102
SHW	Sludge Heating Water	Orange 12473
NAOCL	Sodium Hypochlorite	Yellow 13591
SPW	Spray Water	Navy 15052
STA	Starting Air (Engine Air)	Green 14187
STMR	Steam Return (Condensate)	Tan 11670

**GENERAL SPECIFICATION 15076 – PIPING AND EQUIPMENT IDENTIFICATION**

---

<b>Pipeline Identification</b>		
<b>ABBR.</b>	<b>Process/Service Line</b>	<b>Fed. Std. 595B Color</b>
STMS	Steam Supply	Orange 22356
STD	Storm Drain	Gray 16440
SULAD	Sulfuric Acid	Brown 10049
SD	Sump Drain	Gray 16376
SU	Supernatant	Gray 16307
TS	Thickened Sludge	Brown 10070
TD	Thickener Drain	Gray 16187
TO	Thickener Overflow	Gray 16329
VCS	Vacuum Service	Green 14062
WAS	Waste Activated Sludge	Tan 13596
WDGS	Waste Digester Gas	Orange 22510
WML	Waste Mixed Liquor	Tan 12648
WO	Waste Oil	White 17925
WSC	Washed/Compacted Screenings	Black 14084

Note 1: The following colors shall be used for Mixed Sludge and Digester Sludge Recirculation

<b>Digester No.</b>	<b>Color</b>	<b>Digester No.</b>	<b>Color</b>
1	13531	5	10219
2	13522	6	10115
3	10324	7	10080
4	10371	8	10055

**PART 3 EXECUTION**

**3.01 LOCATION**

- A. Locate identification signs for piping along straight line runs at intervals of not more than 30 feet, near valves, branches and junction points and where pipes pass through walls or ceilings. Place direction-of-flow arrows as shown or

## GENERAL SPECIFICATION 15076 – PIPING AND EQUIPMENT IDENTIFICATION

---

required. Locate signs on large valves on or adjacent to the valve itself. Place all piping identification signs so as to be easily visible from operating locations. Locate nameplates on equipment bases and on structures at readily visible levels in such positions relative to the equipment and structures so as to prevent damage to the nameplate.

### 3.02 MOUNTING

- A. Mount identification signs and arrows on piping parallel and tangent to the pipe and valves by fastening with screws, plastic or fiber washers, threaded brackets and banding straps and seals. Provide screws and brackets of stainless steel with 5/16 - 18 American Standard Coarse Threads; provide No. 25 U.S. gauge stainless steel, 3/4 inch wide bands.
- B. Where pipe is insulated, use care in mounting the signs so to prevent the banding straps from crushing the insulation.
- C. Provide mounting assembly "Steelbinder" strapping unit as manufactured by:
  - 1. A.J. Gerrard & Co., LakeLake City, FL..
  - 2. Independent Metal Strap, Roslyn, N.Y.
  - 3. Or approved equal.
- D. Mount nameplates in a manner specifically approved by the Engineer after the installation of equipment or construction of structures. Submit details of the method of fastening to the Engineer for approval. Provide fastening devices for nameplates and valves of stainless steel construction.
- E. Mount valve identification signs with approved stainless steel brackets or approved stainless steel strapping in such a fashion that sharp corners or edges on signs, brackets, bolts, chain or strapping will not constitute a hazard to personnel operating the valves. Since it is impractical to detail each means of attachment in the Contract Drawings, each means of attachment will receive approval only on its own merits. Submit for approval sketches of each type proposed.
- F. Do not attach identification tags or signs to handwheels. Use of flange bolts or bonnet bolts as a means of attachment of brackets will receive consideration. Provide all attachment devices and bolting of Type 304 stainless steel.

END OF SECTION

NO TEXT ON THIS PAGE

**SECTION 15081  
Piping Insulation**

**PART 1 GENERAL**

**1.01 SECTION INCLUDES**

- A. This Section includes insulation and jacketing requirements for piping systems, including piping, valves and accessories. The Contractor shall provide all labor, materials, equipment and incidentals as shown, specified or required to furnish and install the piping insulation work.
- B. The following index of this Section is included for convenience.

<u>Article</u>	<u>Title</u>	<u>Page</u>
		15081-
PART 1	GENERAL .....	1
1.01	Section Includes .....	1
1.02	Related Sections.....	1
1.03	Payment.....	2
1.04	References.....	2
1.05	Submittals .....	2
1.06	Quality Assurance And Qualifications .....	3
1.07	Delivery, Storage And Handling.....	3
PART 2	PRODUCTS.....	3
2.01	Manufacturers .....	3
2.02	Flame/Smoke Ratings .....	4
2.03	Building Code Compliance.....	4
2.04	Materials .....	4
PART 3	EXECUTION.....	8
3.01	Inspection.....	8
3.02	Installation.....	8
3.03	Existing Insulation Repair.....	10
3.04	Protection And Replacement .....	10
3.05	Painting And Cleaning.....	10
3.06	General Contract Piping System Insulation Schedule .....	10
3.07	Hvac Contract Piping System Insulation Schedule .....	12
3.08	Plumbing Contract Piping System Insulation Schedule .....	13

**1.02 RELATED SECTIONS**

- A. Section 09900 - Painting
- B. Section 15060 - Hangers and Supports

## GENERAL SPECIFICATION 15081 - PIPING INSULATION

---

### 1.03 PAYMENT

- A. Payment will be made as provided herein.
- B. No separate payment will be made for disinfection or testing piping, gaskets, bolts, nuts and other appurtenances and material required to erect the lines; the costs thereof shall be included in the prices bid for Piping Insulation

### 1.04 REFERENCES

- A. The following standards are referenced in this Section:
  - 1. ASTM C240 - Standard Test Methods of Testing Cellular Glass Insulation Block.
  - 2. ASTM C411 - Standard Test Method for Hot-Surface Performance of High-Temperature Thermal Insulation.
  - 3. ASTM C534 - Standard Specification for Preformed Flexible Elastomeric Cellular Thermal Insulation in Sheet and Tubular Form.
  - 4. ASTM C552 - Standard Specification for Cellular Glass Thermal Insulation.
  - 5. ASTM C547 - Standard Specification for Mineral Fiber Pipe Insulation
  - 6. ASTM C1136 - Standard Specification for Flexible, Low Permeance Vapor Retarders for Thermal Insulation.
  - 7. ASTM D1056 - Standard Specification for Flexible Cellular Materials - Sponge or Expanded Rubber.
  - 8. ASTM E84 - Standard Test Method for Surface Burning Characteristics of Building Materials.
  - 9. ASTM E96 - Standard Test Method for Water Vapor Transmission of Materials.
  - 10. Building Code of the City of New York.
  - 11. New York State Energy Conservation Code.
  - 12. NFPA255 - Surface Burning Characteristics of Building Materials.

### 1.05 SUBMITTALS

- A. General: The Contractor shall submit Shop Drawings and all submittals for the approval of the Engineer. Submittals shall include, but not be limited, to:
  - 1. Product Data: insulation and related materials. Submit the manufacturer's technical product data, insulation materials, densities, fire ratings, flame-spread ratings, smoke-developed ratings, fuel contributed ratings, material safety data sheets and installation

instructions for each type of piping insulation and related materials. Submit a schedule showing the manufacturer's product number, k-value, thickness, and furnished accessories for each piping system requiring insulation.

2. Stainless Steel Jacketing: Submit the manufacturer's technical data for jacketing and related materials.
3. Installation Drawings: Complete assembly, layout and installation drawings with clearly marked dimensions.

1.06 QUALITY ASSURANCE AND QUALIFICATIONS

- A. Manufacturer's Qualifications: Provide insulation from firms regularly engaged in manufacture of piping insulation products, of the types and sizes required, whose products have been in satisfactory use in similar services for not less than 3 years.
- B. Installer's Qualifications: Use a single firm with at least 5 years successful installation experience on projects with insulations similar to that required for this project.

1.07 DELIVERY, STORAGE AND HANDLING

- A. General: Deliver, store and handle all products and materials as specified in Contract Documents and as follows:
  1. Labeling: Deliver the insulation, coverings, cements, adhesives, and coatings to the site in containers with the manufacturer's stamp or label, affixed showing the fire hazard indexes of products.
  2. Protection: Protect the insulation against dirt, water, and chemical and mechanical damage. Do not install damaged or wet insulation. Remove damaged materials from the project site.

PART 2 PRODUCTS

2.01 MANUFACTURERS

- A. The insulations used may be as manufactured by:
  1. Style A Insulation:
    - a. Johns Manville, a Berkshire Hathaway company, Berlin, NJ.
    - b. Owens-Corning Company, Toledo, OH.
    - c. Or approved equal.
  2. Style B Insulation:
    - a. Armstrong World Industries, Inc., Lancaster, PA. This manufacturer is no longer active for selling insulation products.

## GENERAL SPECIFICATION 15081 - PIPING INSULATION

---

- b. Rubatex Corp., Bedford, VA. This manufacturer is no longer active for selling insulation products and you have to find another one.
  - c. Or approved equal.
- 3. Style C Insulation:
  - a. Pittsburgh Corning Corp., Port Allegany, PA.
  - b. Or approved equal.
- 4. Style D Insulation:
  - a. Johns Manville, a Berkshire Hathaway company, Denver, CO.
  - b. Owens-Corning Company, Toledo, OH.
  - c. Or approved equal.
- 5. Stainless Steel Jacketing:
  - a. Childers Product Company, Lock-On, Cleveland, OH. This manufacturer is no longer active and you have to find another one for stainless steel jacketing.
  - b. Or approved equal.
- 6. Thermal Hanger Shields:
  - a. Pipe Shields Inc., Fairfield, CA.
  - b. Or approved equal.

### 2.02 FLAME/SMOKE RATINGS

- A. Piping insulation shall have a composite (insulation, jackets, coverings, sealers, mastics and adhesives) flame-spread index of 25 or less, fuel-contributed rating of 50 or less, and smoke-developed index of 50 or less, as tested by ASTM E84 (NFPA255) method. Any treatments of jackets or facings to impart flame and smoke safety shall be permanent. The use of water-soluble treatments shall be prohibited.

### 2.03 BUILDING CODE COMPLIANCE

- A. Piping insulation products shall comply with the Building Code of the City of New York and with the New York State Energy Conservation Code.

### 2.04 MATERIALS

- A. Style A Insulation - Molded Fiberglass Pipe Insulation
  - 1. Style A insulation shall be heavy-duty, bonded fibrous glass sectional pipe insulation with a thermal conductivity not exceeding 0.26 BTU per hour per square foot per degree F per inch thickness at 50 degrees F mean temperature and not exceeding 0.3 BTU per hour per square foot



per degree F per inch thickness at 200 degrees F mean temperature. Insulation shall be provided with factory-applied vapor retarder. The vapor retarder shall be an ASJ (all-service jacket) type meeting the requirements of ASTM C1136 Type 1 and consisting of laminated white kraft paper, reinforcing scrim and foil. The insulation shall meet the requirements of ASTM C547, Type 1. Insulation shall be rated for use at temperatures up to 850 degrees F.

2. Joints and Seams: Provide joints and seams meeting one of the following requirements
  - a. Field cemented joints: All joints and seams shall be sealed with approved adhesive, and the joints covered with joint sealing tape at least 3 inches in width, permanently adhered.
  - b. Sealing strips: All longitudinal joints shall be sealed with integral adhesive sealing strip, and butt joints shall be covered with 3-inch width of vapor barrier butt joint strip tape.
3. Fittings, flanges and valves: Provide insulation meeting one of the following requirements
  - a. Fittings, flanges and valves shall be insulated with fiber glass molded or segmented insulation, and wrapped with joint sealing tape of matching color.
  - b. Alternatively, fittings, flanges and valves may be insulated with factory cut glass blanket.

**B. Style B Insulation - Flexible Elastomeric Cellular Insulation**

1. Style B insulation shall be flexible elastomeric type, closed cell, cylindrical or sheet type as required by the application. Flexible elastomeric insulation shall have a thermal conductivity not exceeding 0.27 BTU per hour per square foot per degree F per inch thickness at 75 degrees F mean temperature. Water absorption shall be less than 5% (ASTM D1056). Water vapor permeability shall not exceed 0.10 perms per inch in accordance with ASTM E96 Procedure A. The insulation shall meet the requirements of ASTM C534 and ASTM D1056.
2. Joints and Seams: All joints shall be cut straight and butted with no gaps. Seal all joints with the manufacturer's recommended adhesive.
3. Fittings, flanges and valves:
  - a. Seams and mitered joints shall be adhered using the manufacturer's recommended adhesive. Screwed fittings shall be sleeved and adhered with a minimum one-inch overlap onto the adjacent insulation.

## GENERAL SPECIFICATION 15081 - PIPING INSULATION

---

- b. Flanges, strainers, couplings and valves shall be insulated using donuts, then covered with sheet or oversize tubular insulation.
  - 4. Coating
    - a. Where insulation is installed outdoors, coatings shall be provided to protect the insulation from ultraviolet radiation. Coatings shall be as recommended by the insulation manufacturer and approved by the Engineer.
- C. Style C Insulation - Cellular Glass
  - 1. Cellular glass insulation shall have a water absorption not exceeding 0.2 percent (ASTMC240), have 0.20 perms-inch water vapor permeability (ASTM E96), service temperature range of at least 0 to 220 degrees F, a minimum density of 8.0 lbs per cubic foot, compressive strength of 100 psi, and maximum thermal conductivity of 0.32 BTU per hour per square foot per degree F per inch thickness at 75 degrees F average temperature. Where field-applied stainless steel jacketing is not required over the insulation, the insulation shall be provided with a factory-applied facing of aluminum foil laminated to glass fiber reinforced white vinyl facing. The insulation shall meet the requirements of ASTM C552.
  - 2. Joints and Seams:
    - a. Insulation joints shall be sealed with the insulation manufacturer's recommended vapor-resistant joint sealant.
    - b. Factory-applied facing shall have its longitudinal seams sealed with vapor-resistant adhesive and butt joints shall be wrapped with 3-inch width joint sealing tape, all as recommended by the insulation manufacturer and approved by the Engineer.
  - 3. Fittings, flanges and valves: Fittings, flanges and valves shall be insulated with preformed cellular glass insulation. Fitted insulation segments shall be used on sizes for which preformed shapes are not manufactured, of the same material and thickness and applied in the same manner as for pipe insulation.
  - 4. Where indicated on the Contract Drawings or in the Contract Documents, the interior bore of the insulation shall be coated to prevent abrasion of the pipe. For pipe operating near ambient temperature, the coating shall be a gypsum cement molding plaster such as U. S. Gypsum Hydrocal B-11, or approved equal, as recommended by the insulation manufacturer.
- D. Style D Insulation - Fiberglass Pipe and Tank

## GENERAL SPECIFICATION 15081 - PIPING INSULATION

---

1. Style D insulation shall be fiberglass pipe and tank insulation consisting of semi-rigid fiberglass board bonded to a flexible vapor retarder. Insulation shall have a thermal conductivity not exceeding 0.27 BTU per hour per square foot per degree F per inch thickness at 75 degrees F mean temperature and 0.43 BTU per hour per square foot per degree F per inch thickness at 250 degrees F mean temperature. Insulation shall be rated for use over an operating temperature range of 0 to 650 degrees F in accordance with ASTM C411. Insulation shall be provided with factory applied vapor retarder. The vapor retarder shall be an ASJ (all service jacket) type consisting of laminated white kraft paper, reinforcing scrim and foil. ASJ shall be rated for use over a temperature range of -20 to 150 degrees F and shall meet the requirements of ASTM C1136 Type 1.
  2. Joints and Seams: All joints and seams shall be sealed with approved adhesive, and the joints covered with joint sealing tape at least 3 inches in width, permanently adhered.
  3. Fittings, flanges and valves: Provide insulation meeting one of the following requirements
    - a. Fittings, flanges and valves shall be insulated with fiber glass molded or segmented insulation, and wrapped with joint sealing tape of matching color.
    - b. Alternatively, fittings, flanges and valves may be insulated with factory cut glass blanket.
- E. Stainless Steel Jacketing
1. Stainless steel jacketing shall be constructed of Type 316 stainless steel, not less than 0.016-inch thick. It shall have a modified Pittsburgh Z-lock on the longitudinal seam. Jacketing shall be provided with an integrally bonded moisture barrier. Adjacent sections shall butt together and shall be secured with a weather-proof butt strap. Jacketing shall be secured with 3/4-inch wide, 0.015-inch thick stainless steel bands at a maximum spacing of twelve inches. All edges of strapping shall be factory deburred. All insulated fittings shall be finished in the same manner, using 0.024-inch thick type 316 stainless steel preformed fitting covers and fabricated covers made from the same material for valves, flanges, tees, in-line accessories, and other pipeline appurtenances. Type 316 stainless steel end caps shall be provided at the ends of the pipelines.
  2. For piping insulation with an insulation outside diameter greater than 50-inch, provide stainless steel jacketing in accordance with the Contract Documents.

F. Accessories

1. Provide staples, bands, wires and cement as recommended by the insulation manufacturer and approved by the Engineer for the applications indicated.
2. Provide adhesives, sealers, and protective finishes as recommended by the insulation manufacturer and approved by the Engineer for the applications indicated.

G. Thermal Hanger Shields

1. Provide insulated pipe protectors consisting of a 360-degree high density, 100 psi, waterproofed calcium silicate inserts encased in 360-degree sheet metal. On cold water pipes provide protectors with insulation extended 1-inch beyond the sheet metal shield. On heat-traced pipe, protectors shall be provided with grooves to accommodate the heat tracing.
2. Provide the thickness of the insulation insert to be the same as the adjoining pipe insulation, and sheet metal gauge in accordance with the manufacturer's recommendations.
3. Provide metal components manufactured of Type 316 stainless steel. Pipe hangers and supports provided in conjunction with the thermal hanger shields shall meet the requirements of Section 15060 - Hangers and Supports.

**PART 3 EXECUTION**

**3.01 INSPECTION**

- A. General: Examine areas and conditions under which piping insulation is to be installed. Do not proceed with Work until unsatisfactory conditions have been corrected in manner acceptable for insulation installation, as determined by the Engineer.

**3.02 INSTALLATION**

- A. General: Install piping insulation products in accordance with the manufacturer's recommendations and approved shop drawings, and as specified in Contract Documents. Install piping insulation products in accordance with the Building Code of the City of New York. Install all products in accordance with the recognized industry practices so that insulation serves its intended purpose. Insulated thermal hangers shields shall be installed at all support points, except where otherwise indicated.

B. Piping Insulation:

1. Order of Installation: Install insulation on pipe systems subsequent to the installation of heat tracing, painting, testing, and acceptance tests.

## GENERAL SPECIFICATION 15081 - PIPING INSULATION

---

- Piping shall be field tested and approved by the Engineer prior to installation of insulation.
2. Cleaning and Drying: Pipe surfaces shall be cleaned and dried prior to insulating.
  3. Insulation Surfaces: Install the insulation materials with smooth, even and flush adjoining surfaces. Butt insulation joints firmly together to form a complete and tight fit over the surfaces to be covered. Insulate each continuous run of piping with full-length units of insulation, with a single cut piece to complete the run. Do not use cut pieces or scraps abutting each other.
  4. Vapor Barrier: Maintain integrity of the vapor-barrier jackets on pipe insulation, and protect to prevent puncture or other damage. Vapor barrier materials shall be applied to form a complete, unbroken vapor seal over the entire insulated piping system.
  5. Insulating Fittings: Cover valves, fittings and similar items in each piping system with an equivalent thickness and composition of insulation as applied to the adjoining pipe run. Install factory molded, precut or job fabricated units except where a specific form or type is indicated.
    - a. Unless indicated otherwise, piping insulation shall be extended without interruption through interior walls, floors and similar piping penetrations. Annular spaces between pipe and pipe sleeves shall be thoroughly packed with fibrous glass blanket and caulked with mastic so as to be soundproof and vermin-tight. Provide fibrous glass blanket with properties equivalent to the insulation Style installed on the piping.
    - b. Do not extend insulation through walls or floors that are fire rated or are required to be gas-tight.
  6. Pipe Hangers:
    - a. Butt pipe insulation against pipe hanger insulation inserts.
    - b. For hot pipes, apply a 3 inch wide vapor barrier tape or band over the butt joints.
    - c. For cold piping apply a wet coat of the vapor barrier lap cement on butt joints and seal the joints with a 3 inch wide vapor barrier tape or band. Pipe hangers and supports shall be installed outside of the vapor seal.
  7. Removable Items: Install removable insulation sections on the following:
    - a. Devices that require access for maintenance of equipment

## GENERAL SPECIFICATION 15081 - PIPING INSULATION

---

- b. Items that can be removed, such as unions, screwed joints, flanges, strainers, etc.
- C. Stainless Steel Jacketing: Provide stainless steel jacketing over all insulated piping systems. Install jacketing in accordance with the manufacturer's recommendations and approved shop drawings.
- D. Pipe exposed to weather:
  - 1. Pipe hangers and supports shall be on the outside of the stainless steel jackets, and shall not penetrate the jacketing.
  - 2. Do not install thermal hanger shields on pipelines using cellular glass insulation. At each such location, a preformed Type 316 stainless steel insulation shield shall be provided. The insulation shield shall envelope at least the lower half of the insulated pipe and shall limit the compressive load on the insulation to 33 psi or less.
- E. All jacket openings - such as at overlaps of jackets with thermal hanger shields, around valve stems and similar projections - shall be sealed with nonhardening, waterproof, clear or white sealing compound so that upon completion the insulation is essentially watertight.

### 3.03 EXISTING INSULATION REPAIR

- A. Repair sections of existing piping insulation that are damaged during construction. Use insulation of same thickness as the existing insulation. Install a new jacket lapping and sealer over the existing insulation. If existing insulation is painted, paint new insulation to match the existing surface color. If existing insulation is jacketed, replace damaged jacketing with new jacket.

### 3.04 PROTECTION AND REPLACEMENT

- A. Protection: Insulation shall be protected against dirt, water, chemical or mechanical damage before, during and after installation. Follow methods which are required for protection of the insulation work during the remainder of construction period, to avoid damage and deterioration.
- B. Replacement: Any insulation or covering damaged prior to final acceptance of the work shall be satisfactorily repaired or replaced, including units with vapor barrier damage and moisture saturated units.

### 3.05 PAINTING AND CLEANING

- A. Piping insulation shall be painted in accordance with Section 09900 - Painting.
- B. The Contractor shall remove all debris, waste materials and loose foreign matter resulting from installation.

## GENERAL SPECIFICATION 15081 - PIPING INSULATION

---

### 3.06 GENERAL CONTRACT PIPING SYSTEM INSULATION SCHEDULE

- A. General: In addition to the requirements above, the Contractor shall provide piping insulation on the following mechanical piping systems and as indicated herein.
- B. Thickness: Where not indicated otherwise, the Contractor shall provide the following minimum insulation thicknesses:
  - 1. Insulation shall be 1-inch thick for pipe sizes up to and including 6 inches.
  - 2. Insulation shall be 1-1/2-inch thick for pipe over 6 inches.
- C. Cold Piping Systems
  - 1. Style: Insulation shall be Style ~~A~~B.
  - 2. Install on the following for the purpose of eliminating sweating:
    - a. City water systems
    - b. Service water systems
- D. Hot Piping Systems (to 250 Degrees F)
  - 1. Style:
    - a. Insulation shall be Style A for pipe sizes up to and including 30-inch.
    - b. Insulation shall be Style D for pipe sizes greater than 30-inch.
  - 2. Thickness: The Contractor shall provide the following minimum thicknesses for the purpose of reducing heat loss and preventing injury to workers:
    - a. Insulation shall be 1-1/2-inch thick for pipe sizes up to and including 2-inch
    - b. Insulation shall be 2-inch thick for pipe sizes 2-1/2-inch through 6 inches.
    - c. Insulation shall be 2-1/2-inch thick for pipe sizes 8-inch through 30-inch.
    - d. Insulation shall be 3-inch thick for pipe sizes greater than 30-inch.
  - 3. Install on the following:
    - a. Heated sludge piping systems
    - b. Hot water piping systems
    - c. Hot air piping systems

## GENERAL SPECIFICATION 15081 - PIPING INSULATION

---

- d. Digester gas piping systems
- e. Interior heat-traced piping systems
- E. Steam and condensate piping systems shall be insulated as specified below in Articles 3.07D AHot Low Pressure (to 250 degrees F) HVAC Piping Systems@ and 3.07E, AHot Fluids (251 degrees F to 350 degrees F) HVAC Piping Systems@
- F. Exterior Piping Systems
  - 1. Style: Insulation shall be Style C.
  - 2. Thickness: Insulation shall be a minimum 2-inches thick.
  - 3. Install on the following:
    - a. Exterior piping systems that are heat-traced for freeze protection.

### 3.07 HVAC CONTRACT PIPING SYSTEM INSULATION SCHEDULE

- A. General: In addition to the requirements above, the Contractor shall provide piping insulation on HVAC piping systems as indicated below and as indicated herein.
- B. Sub-Freezing Piping (0 to 39 degrees F) HVAC Piping Systems
  - 1. Style: Insulation shall be Style B
  - 2. Thickness:
    - a. Insulation shall be 1-inch thick for pipe sizes up to and including 1-inch
    - b. Insulation shall be 1-1/2 inch thick for pipe sizes over 1-inch.
  - 3. Install on the following for the purpose of eliminating sweating:
    - a. Refrigerant suction lines systems between evaporators and compressors.
- C. Cold Piping (40 degrees F to ambient) HVAC Piping Systems
  - 1. Style: Insulation shall be Style A
  - 2. Thickness:
    - a. Insulation shall be 1-inch thick for pipe sizes up to and including 4 inches
    - b. Insulation shall be 1-1/2-inch thick for pipe sizes over 4 inches
  - 3. Install on the following for the purpose of eliminating sweating:
    - a. HVAC chilled water supply and return piping systems.



## GENERAL SPECIFICATION 15081 - PIPING INSULATION

---

- b. HVAC make-up water piping systems.
  - c. Air conditioner condensate drain piping systems.
- D. Hot Low Pressure (to 250 degrees F) HVAC Piping Systems
- 1. Style: Insulation shall be Style A
  - 2. Thickness:
    - a. Insulation shall be 1-1/2-inch thick for pipe sizes up to and including 2 inches
    - b. Insulation shall be 2-inch thick for pipe sizes 2-1/2 inches through 6 inches
    - c. Insulation shall be 2-1/2-inch thick for pipe sizes 8-inch and greater
  - 3. Install on the following for the purpose of reducing heat loss and preventing injury to workers:
    - a. HVAC hot water (glycol solution) supply and return piping systems
    - b. Hot gas refrigerant piping systems
    - c. Low pressure steam and condensate piping systems
- E. Hot Fluids (251 degrees F to 350 degrees F) HVAC Piping Systems
- 1. Style: Insulation shall be Style A
  - 2. Thickness:
    - a. Insulation shall be 2-inch thick for pipe sizes up to and including 1 inch
    - b. Insulation shall be 2-1/2-inch thick for pipe sizes 1-1/4-inch through 4 inches
    - c. Insulation shall be 3-1/2-inch thick for pipe sizes over 4 inches
  - 3. Install on the following for the purpose of reducing heat loss and preventing injury to workers:
    - a. High pressure steam and condensate piping systems
- F. Exterior Piping Systems
- 1. Style: Insulation shall be Style C.
  - 2. Thickness: Insulation shall be a minimum 2-inches thick.
  - 3. Install on the following:

## GENERAL SPECIFICATION 15081 - PIPING INSULATION

---

- a. Exterior piping systems that are heat-traced for freeze protection.
  - G. Insulation Omitted: Omit insulation on hot piping within radiation enclosures or unit cabinets, on cold piping within unit cabinets provided that the piping is located over a drain pan and on heating piping beyond a control valve, located within heated space.
- 3.08 PLUMBING CONTRACT PIPING SYSTEM INSULATION SCHEDULE
- A. General: In addition to the requirements above, the Contractor shall provide insulation for plumbing piping systems as indicated below and as indicated herein.
  - B. Cold Plumbing Piping Systems
    - 1. Style: Insulation shall be Style A
    - 2. Thickness: Insulation shall be 1-inch thick.
    - 3. Install on the following for the purpose of eliminating sweating:
      - a. Potable cold water piping systems
      - b. Interior above-ground storm water piping systems
      - c. Plumbing vents within 6 lineal feet of a roof opening
      - d. Drain piping systems from drip pans
  - C. Hot Plumbing Piping Systems
    - 1. Style: Insulation shall be Style A
    - 2. Thickness:
      - a. Insulation shall be 1-inch thick for pipe sizes less than or equal to 6 inches
      - b. Insulation shall be 1-1/2-inches thick for pipe sizes greater than 6 inches
    - 3. Install on the following for the purpose of reducing heat loss and preventing injury to workers:
      - a. Potable hot water piping systems
      - b. Potable hot water recirculating piping systems
      - c. Hot drain piping systems
      - d. Tempered water piping systems
  - D. Insulation Omitted: Omit the insulation on chrome-plated exposed piping (except for handicapped fixtures), air chambers, unions, strainers, check valves, balance cocks, flow regulators, drain lines from water coolers, drainage piping

## **GENERAL SPECIFICATION 15081 - PIPING INSULATION**

---

located in crawl spaces or tunnels, buried piping, fire protection piping, and preinsulated equipment.

END OF SECTION

**GENERAL SPECIFICATION 15081 - PIPING INSULATION**

---

NO TEXT ON THIS PAGE

**SECTION 15112  
Valves Smaller Than 4 Inches**

**PART 1 GENERAL**

**1.01 SUMMARY**

- A. Contractor shall provide all labor materials, equipment and incidentals as shown, specified and required to furnish and install valves smaller than 4 inches complete with appurtenances and operational. All valves smaller than 4 inches shall be furnished under this Section unless specifically indicated in this section and shown on the Contract Drawings.
- B. The following index of this Section is included for convenience.

<u>Article</u>	<u>Title</u>	<u>Page</u>
		15112-
PART 1	GENERAL .....	1
1.01	Summary .....	1
1.02	Payment.....	2
1.03	Related Sections.....	2
1.04	References.....	2
1.05	General Requirements.....	2
1.06	Submittals .....	3
1.07	Quality Assurance.....	3
1.08	Delivery, Storage And Handling.....	4
1.09	Spare Parts .....	4
PART 2	PRODUCTS.....	4
2.01	Manufacturers .....	4
2.02	Materials - General .....	6
2.03	Valves For Metallic Pipe Lines.....	7
2.04	Valves For Thermoplastic Piping .....	9
2.05	Appurtenances And Miscellaneous Items.....	10
2.06	Testing.....	12
2.07	Painting .....	13
PART 3	EXECUTION.....	13
3.01	Installation.....	13
3.02	Field Tests And Adjustments.....	13
3.03	Manufacturer's Service.....	13

## GENERAL SPECIFICATION 15112 - VALVES SMALLER THAN 4 INCHES

### 1.02 PAYMENT

- A. There shall be no separate payment for the work of this Section; all costs shall be included in the Lump Sum price bid for the Contract.

### 1.03 RELATED SECTIONS

- A. Section 09900 - Painting
- B. Section 15076 - Piping and Equipment Identification
- C. Section 15111 - Valves - 4 Inch and Larger

### 1.04 REFERENCES

- A. American National Standards Institute (ANSI):
  - 1. B16.1 Gray Iron Pipe Flanges and Flanged Fittings: Classes 25, 125, and 250
- B. American Society for Testing and Materials (ASTM):
  - 1. A126 Standard Specification for Gray Iron Castings for Valves, Flanges and Pipe Fittings
  - 2. A193 Standard Specification for Alloy-Steel and Stainless Steel Bolting Materials for High Temperature or High Pressure Service and Other Special Purpose Applications
  - 3. A307 Standard Specification for Carbon Steel Bolts, Studs, and Threaded Rod 60,000 PSI Tensile Strength
  - 4. A536 Standard Specification for Ductile Iron Castings.
- C. American Water Works Association (AWWA):
  - 1. C500 Metal-Seated Gate Valves for Water Supply Service
  - 2. C508 Swing-Check Valves for Waterworks Service, 2 in. through 24 in.
  - 3. C509 Resilient-Seated Gate Valves for Water Supply Service
  - 4. C542 Electric Motor Actuators for Valves and Slide Gates
- D. Military Specification:
  - 1. MIL-C-27487 Coupling Halves, Quick-Disconnect, Cam-Locking Type.
- E. National Electrical Manufacturers Association (NEMA):
  - 1. Enclosure Type 4X

### 1.05 GENERAL REQUIREMENTS

- A. All valves shall turn clockwise to close, unless otherwise specified.
- B. All valves shall have permanent markings for direction to open.

## **GENERAL SPECIFICATION 15112 - VALVES SMALLER THAN 4 INCHES**

---

- C. All materials of construction of the valves shall be confirmed suitable for the application by the valve manufacturer.
- D. All valves shall have manufacturer's name and rated pressure cast in raised letters on the valve body.
- E. The valves shall be provided with identification conforming to the requirements of Section 15076 - Piping and Equipment Identification.

### **1.06 SUBMITTALS**

- A. Contractor shall submit Shop Drawings for approval of the Engineer. Submittals shall include, but not be limited to: Shop Drawings:
  - 1. Product data sheets for make and model.
  - 2. Complete catalog information, descriptive literature, specifications, and identification of materials of construction.
  - 3. Power and control wiring diagrams, including terminals and numbers.
  - 4. Manufacturer's qualifications.
  - 5. Confirmation of suitability of the valve materials for the application.
  - 6. Complete motor nameplate data.
  - 7. Certificates of compliance with AWWA Standards where applicable.
  - 8. Spare Parts List.
  - 9. Special Tools List.
  - 10. Valve manufacturer(s) certified test results of shop testing specified in this section shall be submitted for all valves.
- B. Operation and Maintenance Data: Submit complete manuals including:
  - 1. Copies of all Shop Drawings, test reports, maintenance data and schedules, description of operation, and spare parts information.
- C. Samples:
  - 1. One foot of chain for chain wheel operated valves.

### **1.07 QUALITY ASSURANCE**

- A. Manufacturer's Qualifications:
  - 1. Manufacturer shall have a minimum of 5 years of experience in the production of substantially similar valve equipment, and shall show evidence of satisfactory service in at least 5 installations.
  - 2. Each type of valve shall be the product of one manufacturer.

## GENERAL SPECIFICATION 15112 - VALVES SMALLER THAN 4 INCHES

### 1.08 DELIVERY, STORAGE AND HANDLING

- A. Protection of materials and equipment shall be as required herein.
- B. Valves and appurtenances shall be handled carefully. Valves which are dropped, dented, cracked or otherwise damaged will not be acceptable.

### 1.09 SPARE PARTS

- A. The following quantities of spare valves shall be furnished for each type and size of valve installed.

Number of Valves Installed	Sets of Spare Valves Required
1-5	1
6-10	2
11-15	3
16-30	5
Greater than 30	add 1 for every 10 additional valves

## PART 2 PRODUCTS

### 2.01 MANUFACTURERS

- A. The Approved products shall be:
  - 1. Solenoid Valves as manufactured by:
    - a. Automatic Switch Company, Florham Park, NJ.
    - b. Automatic Valve Corporation, Novi, MI.
    - c. Or approved equal.
  - 2. Ball Valves as manufactured by:
    - a. Stockham Valves and Fitting Company, Cullman, AL.
    - b. CVC Valves, former Lunkenheimer Company, Cincinnati, OH.
    - c. Or approved equal.
  - 3. Globe Valves as manufactured by:
    - a. Stockham Valves and Fitting Company, Cullman, AL.
    - b. CVC Valves, former Lunkenheimer Company, Cincinnati, OH.
    - c. Or approved equal.
  - 4. Check Valves as manufactured by:



## GENERAL SPECIFICATION 15112 - VALVES SMALLER THAN 4 INCHES

---

- a. Stockham Valves and Fitting Company, Cullman, AL.
  - b. CVC Valves, former Lunkenheimer Company, Cincinnati, OH.
  - c. Or approved equal.
5. Gate Valves as manufactured by:
- a. Stockham Valves and Fitting Company, Cullman, AL.
  - b. CVC Valves, former Lunkenheimer Company Cincinnati, OH.
  - c. Or approved equal.
6. Needle Valves as manufactured by:
- a. Stockham Valves and Fitting Company, Cullman, AL.
  - b. CVC Valves, former Lunkenheimer Company, Cincinnati, OH.
  - c. Or approved equal.
7. Pressure Reducing Valves as manufactured by:
- a. Cla-Val Company, Milford, CT.
  - b. Watts Water Technologies, Inc., North Andover, MA.
  - c. Or approved equal.
8. Hose Valves as manufactured by:
- a. Crane Co., Stamford, CT.
  - b. Powell Valves, Cincinnati, OH.
  - c. Or approved equal.
9. Thermoplastic Ball Valves as manufactured by:
- a. Asahi/America, Lawrence, MA.
  - b. Hayward Industries, Inc., Elizabeth, NJ.
  - c. Or approved equal.
10. Thermoplastic Check Valves as manufactured by:
- a. Asahi/America, Lawrence, MA.
  - b. Hayward Industries, Inc., Elizabeth, NJ.
  - c. Or approved equal.
11. Thermoplastic Diaphragm Valves as manufactured by:
- a. Asahi/America, Lawrence, MA.
  - b. Hayward Industries, Inc., Elizabeth, NJ.

## GENERAL SPECIFICATION 15112 - VALVES SMALLER THAN 4 INCHES

- c. Or approved equal.
- 12. Thermoplastic Butterfly Valve as manufactured by:
  - a. Thermoplastic Valves Incorporated, Emmaus, PA.
  - b. Chemtrol, Division of Nibco, Inc., Elkhart, IN.
  - c. Or approved equal.
- 13. Corporation Stops as manufactured by:
  - a. Mueller Company, Chattanooga, TN.
  - b. A.Y. McDonald Manufacturing Company, Dubuque, IA.
  - c. Or approved equal.
- 14. Strainers as manufactured by:
  - a. Mueller Steam Specialty Company, St. Pauls, NC.
  - b. Armstrong International, Stuart, FL
  - c. Or approved equal.
- 15. Quick Connect Couplings - Water Service as manufactured by:
  - a. Civacon, Kansas City, Missouri.
  - b. Kamlok, Lebanon, Ohio.
  - c. Blackmer, A Dover Resources Company, Grand Rapids, MI.
  - d. PT Coupling Company, Enid, OK.
  - e. Or approved equal.
- 16. Quick Connect Couplings - Chemical Service as manufactured by:
  - a. Banjo Corporation, Crawfordsville, IN.
  - b. Bee Valve, Inc., Elyria, OH.
  - c. Or approved equal.
- 17. Dielectric Pipe Couplings as manufactured by:
  - a. Watts Regulator Company, Lake Villa, IL.
  - b. Or approved equal.
- 18. Electric Motor Actuators as manufactured by:
  - a. Limitorque, Lynchburg, VA.
  - b. Rotork Controls Inc., Rochester, NY.
  - c. EIM Missouri City, Texas.
  - d. AUMA Actuators, Canonsburg, PA.

## GENERAL SPECIFICATION 15112 - VALVES SMALLER THAN 4 INCHES

---

- e. Or approved equal.
  - 19. Valve Chain Operators as manufactured by:
    - a. Babbitt Steam Speciality Co, New Bedford, MA.
    - b. Or approved equal.
  - 20. Plug Valves as manufactured by:
    - a. DeZurik Plug Valves, Sartell, MN.
    - b. Or approved equal.
  - 21. Pinch Valves as manufactured by:
    - a. Red Valve Company, Inc., Carnegie, PA.
    - b. Or approved equal.
- 2.02 MATERIALS - GENERAL
- A. Non-ferrous Materials:
    - 1. Non-ferrous materials are materials consisting of mixtures of copper, tin, zinc, lead, or other metals in which iron does not predominate.
    - 2. Non-ferrous materials shall have standard composition and physical properties conforming to ASTM standards except as otherwise indicated.
  - B. Valves:
    - 1. Cast iron valves shall conform to ASTM A126, Class A.
    - 2. Type 316 stainless steel bolts and studs shall conform to ASTM A193, Grade B.
    - 3. Carbon steel bolts shall conform to ASTM A307, Grade A.
- 2.03 VALVES FOR METALLIC PIPE LINES
- A. Solenoid Valves:
    - 1. Type: Packless construction with screwed end connections and threaded conduit connection.
    - 2. Materials: Bronze body and wetted parts with type 304 stainless steel hardware.
    - 3. Coil: Continuous duty, epoxy encapsulated.
    - 4. Failure Mode: Fail open, energize to close.
    - 5. Electrical Power: 120 volt, 60 Hz, single phase.
    - 6. Each solenoid valve shall be protected with a strainer upstream.

## GENERAL SPECIFICATION 15112 - VALVES SMALLER THAN 4 INCHES

- B. Ball Valves:
1. Body: Bronze, semi-steel or Stainless Steel as specified herein.
  2. Ball, Stem Handle and Hardware: Type 316 stainless steel.
  3. Seat, Packing and Gasket: Teflon.
  4. End Connections: Screwed.
  5. Rating: 150 psig Water, Oil or Gas (W.O.G.).
- C. Globe Valves:
1. Type: Composition or plug-type disc, union bonnet.
  2. Materials: Bronze and brass.
  3. End Connections: Screwed.
  4. Rating: 150 psig Steam Working Pressure (SWP).
  5. Compressed Air Piping: Composition disc.
  6. Copper and Brass Piping: Plug-type disc.
- D. Check Valves:
1. Type: Swing, re-grindable bronze disc, screw-in cap.
  2. Materials: Brass and bronze.
  3. End Connections: Screwed.
  4. Rating: 200 psig Steam Working Pressure (SWP).
  5. 2 and 2 2-inch swing check valves shall conform to AWWA C508.
  6. 3-inch and Larger Valves: Conform to the requirements of Section 15111 - Valves - 4 Inch and Larger.
- E. Gate Valves:
1. Type: Solid wedge, rising stem.
  2. Body and Wetted Parts: Bronze.
  3. Handle and Hardware: Type 316 stainless steel.
  4. End Connections: Screwed.
  5. Rating: 150 psig Water, Oil or Gas (W.O.G.).
  6. 3-inch Valves: Resilient seated conforming to the requirements of Section 15111 - Valves - 4 Inch and Larger.
- F. Needle Valves:
1. Type: Long tapered plug for fine flow regulation.

## GENERAL SPECIFICATION 15112 - VALVES SMALLER THAN 4 INCHES

---

2. Body and Wetted Parts: Bronze.
  3. Handwheel: Malleable iron.
  4. Hardware: Type 316 stainless steel.
  5. End Connections: Screwed.
  6. Rating: 150 psig.
- G. Pressure Reducing Valves:
1. Type: Balanced, soft closing, single seat. Constant downstream pressure regardless of upstream pressure or flowrate. Drop tight shutoff when downstream pressure greater than spring setting.
  2. Strainer: Integral with the valve, Type 316 stainless steel.
  3. Body and Cover: Bronze with pressure gauge taps.
  4. Trim: Type 316 stainless steel.
  5. End Connections: Screwed.
  6. Diaphragm: Ethylene Propylene Diene Termopolymer (EPDM), fully guided at top and bottom.
  7. Pressures and Flows: As specified in this section.
- H. Hose Valves:
1. Type: Chicago pattern.
  2. Materials: Bronze body with brass trim.
  3. Operator: Tee handle.
  4. Pipe End Connection: Threaded.
  5. Hose Connection: 1-1/2-inch NPT for 1-1/2 inch hose, quick connect couplings for larger hoses.
- I. Plug Valves:
1. Type: Non-lubricated eccentric with rectangular port (one piece construction).
  2. Materials: Ductile iron, ASTM A536 Grade 65-45-12.
  3. Plug type: Plug faced with either neoprene for use with sewage or Hycar for use with digester gas at temperatures less than 180°F.
  4. Rating: 175 psi.
  5. Stem: Type 316 stainless steel.
- J. Pinch Valves:

## GENERAL SPECIFICATION 15112 - VALVES SMALLER THAN 4 INCHES

1. Type: Full metal body mechanical pinch type with full port opening.
2. Materials: Cast Iron.
3. Pinch tube: Reinforced with calendered nylon.
4. Stem: Non-rising with a non-rising handwheel.
5. Steel Mechanism: Double-acting with pinching of the sleeve occurring equally from two sides. Acme threads shall be used on all valve mechanisms larger than 1-1/2".

### 2.04 VALVES FOR THERMOPLASTIC PIPING

#### A. Ball Valves:

1. Type: True union, full port.
2. Body and Ball: Poly (Vinyl Chloride) (PVC) Compounds, ASTM D 1784.
3. Stem: Type 316 stainless steel.
4. Seats: Teflon.
5. Seals: Viton.
6. O-Rings: Ethylene Propylene Dienne Termopolymer (EPDM).
7. End Connections: Socket solvent welded unions or flanges as required.
8. Rating: 150 psig at 73°F.

#### B. Check Valves:

1. Type: True union, ball.
2. Body and Ball: Chlorinated Poly (Vinyl Chloride) (PVC) Compounds, ASTM D 1784.
3. Seats: Teflon.
4. Seals: Viton.
5. O-rings: Ethylene Propylene Dienne Termopolymer (EPDM).
6. End Connections: Socket solvent welded unions or flanges as required.
7. Rating: 150 psig at 73°F.

#### C. Diaphragm Valves:

1. Body: Chlorinated Poly (Vinyl Chloride) ((PVC) Compounds, ASTM D 1784.
2. Diaphragm: Teflon.
3. End Connections:

## GENERAL SPECIFICATION 15112 - VALVES SMALLER THAN 4 INCHES

---

- a. 2" and Larger: Flanged, ANSI B16.1 class 125.
  - b. Less than 2": Socket solvent welded unions.
4. Rating: 60 psig at 73°F, bubble tight closure.

### D. Butterfly Valves:

1. Type: Short body.
2. Body: Solid Poly(Vinyl Chloride) (PVC) Compounds.
3. Disc: Poly(Vinylidene Fluoride) (PVDF).
4. Seats and Shaft: Viton.
5. Seat and Shaft Seals: Elastomer.
6. Bearings: Glass-filled Teflon.
7. Operators: Locking handle constructed of reinforced plastic.
8. End Connections:
  - a. 2 1/2 - inch and larger: Flanged ends conforming to ANSI B16.1, Class 125.
  - b. Less than 2-inches: Socket solvent welded unions.

## 2.05 APPURTENANCES AND MISCELLANEOUS ITEMS

### A. Corporation Stops:

1. Type: AWWA standard tapered thread, ball valve.
2. Material: Bronze.
3. End Connection:
  - a. Copper Pipe: Threaded flare.
  - b. Thermoplastic Pipe: Compression with Type 304 stainless steel stiffener rings.

### B. Strainers:

1. Type: Y-pattern.
2. Body:
  - a. Metallic Piping: Bronze, screwed ends.
  - b. Thermoplastic Piping: Chlorinated Poly (Vinyl Chloride) (CPVC) Compounds, true union ends.
3. Screens: Monel, No. 20 mesh, 2.5 times the inlet area.
4. Rating: 125 psig.

## GENERAL SPECIFICATION 15112 - VALVES SMALLER THAN 4 INCHES

- C. Quick Connect Couplings - Water Service:
1. Type: Dual cam and groove, male end dimensionally similar to MIL-C-27487, with dust cap, Type 304 stainless steel chain and lock.
  2. Body: Cast iron.
  3. Cam Arms: Type 304 stainless steel.
  4. Gaskets: Buna-N.
- D. Quick Connect Couplings - Chemical Service:
1. Type: Dual cam and groove, male end dimensionally similar to MIL-C-27487, with dust cap, Type 316 stainless steel chain and lock.
  2. Body: Polypropylene.
  3. Cam Arms: Type 316 stainless steel.
  4. Gaskets: Ethylene Propylene Diene Thermopolymer (EPDM).
  5. End Connections: Solvent socket welded.
- E. Dielectric Pipe Couplings:
1. Provide at every location where copper pipe connects to steel, stainless steel or ductile iron pipe or equipment.
  2. Body: Steel with non-conducting bushings on each end.
  3. End Connections: Screwed.
  4. Rating: 200 psig at 225°F.
- F. Valve Boxes, Floor Boxes and Operating Wrenches:
1. Provide in accordance with Section 15111 - Valves - 4 Inch and Larger.
- G. Electric Motor Actuators: Electric motor actuators shall conform to the requirements of AWWA C542 and shall have the following characteristics.
1. Type: Open-Close, reversing.
  2. Open-Close Time for Ball Valves: 10 seconds.
  3. Open-Close Time for Diaphragm Valves: 60 seconds maximum.
  4. Housing: NEMA 4X with corrosion resistant epoxy coating.
  5. Power: 120 volt, 60 hz, single phase.
  6. SPDT switches shall be provided for remote valve position indication.
  7. Space heater and thermostat shall be provided in the housing.
  8. Integral thermal overload protection shall be provided with automatic reset.



## GENERAL SPECIFICATION 15112 - VALVES SMALLER THAN 4 INCHES

---

9. Limit switches shall be in accordance with Section 15111 - Valves - 4 Inch and Larger.

### H. Valve Chain Operators:

1. All ball, butterfly and diaphragm valves 1-1/2-inch and larger located more than 6 feet-0 inches above the operating floor level shall be equipped with a manual gear operator mounting assembly and a chain operator adapted to fit the gear operator, chain guide and sprocket wheel bolted directly to the valve operating wheel.
2. Aluminum or type 316 stainless steel chain shall be provided to hang three feet above the operating floor. All operators shall be equipped with a 1/2-inch hook bolt located to keep chain out of walking areas or to permit access to equipment.
3. Chain shall be of welded link type with smooth finish. Chain that is crimped and has links type with exposed ends that may scratch or cut the operator shall not be acceptable.
4. A one foot sample of chain shall be provided for approval as specified in Article 1.06.

### 2.06 TESTING

- A. The following valves shall be tested in conformance with the requirement of AWWA Standards:
  1. 3-inch metal-seated gate valve - C500.
  2. 3-inch resilient-seated gate valve - C509.
  3. 2, 2½, and 3-inch swing check valves - C508.
- B. All other valves and valve sizes shall be tested in accordance with the manufacturer's standard test procedures.

### 2.07 PAINTING

- A. All valves and appurtenances shall be painted in accordance with Section 09900 - Painting.

## PART 3 EXECUTION

### 3.01 INSTALLATION

- A. All valves and appurtenances shall be installed in accordance with manufacturer's instructions.
- B. All valves shall be installed so that operating handwheels or wrenches may be conveniently turned from operating floor without interfering with access, and shall be as approved by the Engineer.

## **GENERAL SPECIFICATION 15112 - VALVES SMALLER THAN 4 INCHES**

- C. All valves shall be installed plumb and level. The valves shall be free from distortion and strain caused by misaligned piping, equipment or other causes.
- D. For buried valve installations, the valve boxes shall be set plumb and centered, with carefully tamped to a lateral distance of 4 feet on all sides of the box, or to the undisturbed trench face if less than 4 feet.

### **3.02 FIELD TESTS AND ADJUSTMENTS**

- A. All parts and components shall be adjusted as required to provide correct operation.
- B. A functional field test of each valve shall be conducted in the presence of the Engineer to demonstrate that each part and all components function together correctly.

### **3.03 MANUFACTURER'S SERVICE**

- A. Where required herein the Contractor shall provide the services of qualified factory-trained service technicians to check and approve the installation.

END OF SECTION

**GENERAL SPECIFICATION 15141 – DISINFECTION**

---

**SECTION 15141  
Disinfection**

**PART 1 GENERAL**

**1.01 SECTION INCLUDES**

- A. Disinfection of all pipelines, conduits, pumps, tanks, structures, and equipment which are to store, handle or carry potable water. All labor, chlorine and equipment, including taps, corporation stops, temporary pumps, hoses, miscellaneous piping and other items necessary to perform the work, shall be furnished and installed by the Contractor, and removed after completion of the disinfection procedure. Water for the initial disinfection procedure will be furnished by the City.
- B. The following index of this Section is included for convenience:

<u>Article</u>	<u>Title</u>	<u>Page</u>
		15141-
PART 1	GENERAL.....	1
1.01	Section Includes.....	1
1.02	Payment.....	1
1.03	References.....	1
1.04	Quality Assurance.....	2
PART 2	PRODUCTS (NOT USED) .....	2
PART 3	EXECUTION.....	2
3.01	Pipelines.....	2
3.02	Water Storage Tanks.....	3
3.03	Water Supply .....	3
3.04	Verification Of Disinfection .....	3

**1.02 PAYMENT**

- A. Payment will be made as provided herein.
- B. No separate payment will be made for disinfection or testing piping, gaskets, bolts, nuts and other appurtenances and material required to erect the lines; the costs thereof shall be included in the prices bid for disinfection.

**1.03 REFERENCES**

- A. The following standards are referenced in this Section:

- 1. AWWA C651 - Disinfecting Water Mains

## GENERAL SPECIFICATION 15141 – DISINFECTION

---

2. AWWA C652 - Disinfection of Water-Storage Facilities
3. New York City Plumbing Code
4. New York City Department of Health

### 1.04 QUALITY ASSURANCE

- A. Disinfection shall be in accordance with AWWA C651 for water mains and AWWA C652 for water storage facilities and equipment, except as modified herein. Disinfection procedures for new water mains and water storage facilities shall also conform to the requirements of the New York City Plumbing Code, Section 610 “Disinfection of Potable Water System” and Section 606.5.4.5 “Installation of the Building Water Distribution System - Cleaning or Painting” respectively, except as modified herein.

### PART 2 PRODUCTS (NOT USED)

### PART 3 EXECUTION

#### 3.01 PIPELINES

- A. Pumps, hydrants, and other water handling equipment items that are part of the potable water distribution system shall be disinfected in the same manner as described herein for the pipelines.
- B. Pipelines shall first be flushed with clean water. Disinfection shall be accomplished by the Continuous Feed Method, as specified in AWWA C651, using sodium hypochlorite solution.
- C. Water-chlorine solution with a concentration not less than 50 mg/l of available chlorine shall then be added at one end of the section being disinfected and discharged at the far end. The water-chlorine solution shall be added until the water coming from each downstream blowoff has a residual of not less than 25 mg/l of chlorine.
- D. The pipelines shall then be closed and the solution allowed to remain in the lines for at least 24 hours. The chlorine residual in the pipeline shall then be rechecked. If the free chlorine residual is less than 10 mg/l after 24 hours, the procedure shall be repeated until the free chlorine residual after 24 hours is 10 mg/l or greater.
- E. After the 24-hour holding period, the pipelines and equipment shall be thoroughly flushed and filled with clean water. Flushing water shall not be permitted to enter existing water mains.
- F. Flushing water shall not be discharged to sanitary or storm sewers without permission of the NYCDEP. Where necessary, Federal, State and local regulatory agencies shall be contacted to determine special provisions for the disposal of heavily chlorinated water.

## GENERAL SPECIFICATION 15141 – DISINFECTION

---

- G. When new potable water pipelines are to be connected to an existing water distribution system, the connecting piping shall be disinfected and tested in accordance with the procedure set forth in Section 9.1 or Section 9.2, as applicable, of AWWA C651.

### 3.02 WATER STORAGE TANKS

- A. Potable water storage tanks and other water storage structures shall be disinfected with a solution of sodium hypochlorite and water in accordance with AWWA C652, Method 2 or 3, as modified herein.
  - 1. In Method 2, the spray method, the entire interior surface of the tank or other storage facility, and inlet, outlet and drain piping, shall be sprayed with chlorinated water containing 200 mg/l of available chlorine. The tank shall remain in contact with the strong chlorine solution for at least two hours. Potable water shall then be admitted in sufficient quantity to purge the drain piping of the strong solution. After the drain piping has been purged, the tank shall be filled to the overflow level and allowed to overflow until the chlorine residual drops to approximately 2 mg/l.
  - 2. In Method 3, sodium hypochlorite and water shall be added to the tank in amounts such that the solution will contain 50 mg/l of available chlorine when the tank is filled to approximately 5 percent of the total storage volume. The solution shall be held in the tank for not less than 6 hours, after which the tank shall be filled to the overflow level and let stand for not less than 24 hours. The highly chlorinated water shall then be purged from the drain piping. After the 24-hour period has elapsed, the free-chlorine residual shall be not less than 2 mg/l.

### 3.03 WATER SUPPLY

- A. Water for the first filling, disinfection and flushing procedure of each pipeline, tank and piece of equipment will be furnished by the City, at no cost to the Contractor, from the nearest hydrant or other source. The Contractor shall provide all necessary apparatus to convey the water to the point of use and perform the disinfection procedure. If the water in the pipelines or storage facility fails the bacteriological tests, water for subsequent disinfection procedures shall be provided by the Contractor. If agreeable to the City, water for the subsequent disinfection procedures may be furnished by the City but shall be metered, and the Contractor shall credit the City for the cost of water used for the subsequent procedures.

### 3.04 VERIFICATION OF DISINFECTION

After the completion of disinfection, bacteriological samples shall be taken by the Contractor and tested at a certified laboratory. Samples shall be taken as required by the New York City Department of Health. The test reports shall be submitted to the Engineer for review and approval. If the samples are not satisfactory, the entire disinfection procedure shall be repeated at the expense of the Contractor until satisfactory samples are obtained.

**GENERAL SPECIFICATION 15141 – DISINFECTION**

---

END OF SECTION

## **GENERAL SPECIFICATION 15410 - PLUMBING FIXTURES**

---

### **SECTION 15410 Plumbing Fixtures**

NOTE: This General Specification 15410 – Plumbing Fixtures has been replaced by Detailed Specification 15410 – Plumbing Fixtures in Contract CRO-557P. Wherever a reference appears in the Contract Documents to General Specification 15410, it shall now be deemed to refer to Detailed Specification 15410.

NO TEXT ON THIS PAGE



**SECTION 15760  
Unit Heaters - Hot Water**

**PART 1 GENERAL**

**1.01 SECTION INCLUDES**

- A. The Contractor shall provide all labor, materials, equipment and incidentals as specified and required to furnish and install all unit heaters complete with auxiliary equipment and accessories as shown, specified and/or required for proper operation. Contractor shall furnish and install all supports required.
- B. The equipment shall be furnished complete with all accessories, special tools, spare parts, mountings, anchor bolts and other appurtenances as specified or as may be required for a satisfactory installation.
- C. Units shall be furnished in accordance with the schedule shown on the Contract Drawings.
- D. Index:

<u>Article</u>	<u>Title</u>	<u>Page</u>
		15760-
PART 1	GENERAL .....	1
1.01	Section Includes .....	1
1.02	Related Sections.....	2
1.03	Payment.....	2
1.04	References.....	2
1.05	Submittals .....	2
1.06	Quality Assurance And Qualifications .....	4
1.07	Spare Parts .....	4
PART 2	PRODUCTS.....	4
2.01	Unit Heaters .....	4
2.02	Cabinet Heaters.....	5
2.03	Shop Testing .....	5
PART 3	EXECUTION.....	5
3.01	Installation.....	5
3.02	Identification .....	6
3.03	Painting .....	6
3.04	Field Testing .....	6
3.05	Manufacturer's Representative.....	6
3.06	Adjustments .....	6
3.07	Cleaning .....	6

## **GENERAL SPECIFICATION 15760 - UNIT HEATERS - HOT WATER**

---

### 1.02 RELATED SECTIONS

- A. General Specification 09900 - Painting
- B. General Specification 15076 - Piping and Equipment Identification
- C. General Specification 15951 - Testing, Adjusting and Balancing
- D. General Specification 16221 - Electric Motors

### 1.03 PAYMENT

- A. Payment for work furnished and installed under this Section shall be as provided in the Detailed Specifications.

### 1.04 REFERENCES

- A. Equipment shall comply with applicable provisions and recommendations of the following, except as otherwise shown or specified.
  - 1. American Society of Mechanical Engineers (ASME)
  - 2. American Society of Testing Materials (ASTM)
  - 3. Air Movement and Control Association (AMCA)
  - 4. Air Conditioning and Refrigeration Institute (ACRI)
  - 5. National Electric Code (NEC)
  - 6. Standards of the Hydraulic Institute
  - 7. American National Standard Institute (ANSI)
  - 8. National Fire Protection Association (NFPA)
  - 9. Applicable Federal, State and local laws and/or ordinances
- B. Where conflict arises between the local codes and the requirements of the National Electrical Code, The National Fire Code, ASTM, etc., the more stringent requirements shall prevail.

### 1.05 SUBMITTALS

- A. The Contractor shall submit the Shop Drawings for approval of the Engineer. Submittals shall include, but not be limited, to the following:
  - 1. Shop Drawings.
  - 2. Preliminary Operation and Maintenance Manuals.
  - 3. Final Operation and Maintenance Manuals.
  - 4. Spare Parts List.
  - 5. Reports of Certified Shop Tests.
- B. Each submittal shall be identified by the applicable Equipment Identification Number and Specification Section.

C. Shop Drawings

1. Each submittal shall be complete in all respects, incorporating all information and data listed herein and all additional information required for evaluation of the proposed equipment's compliance with the Contract Documents.
2. Partial, incomplete or illegible submissions will be returned to the Contractor without review for resubmittal.
3. Shop drawings shall include but not be limited to:
  - a. Equipment specifications and data sheets identifying all materials used and methods of fabrication.
  - b. Motor nameplate data as specified in General Specification 16221 - Electric Motors.
  - c. Fan performance data.
  - d. Coil performance data.
  - e. Details of corrosion resistance coating.
  - f. Example equipment nameplate data sheet.
  - g. Interconnecting wiring diagrams.
  - h. List of recommended lubricants.

D. Operations and Maintenance Manuals

1. The Contractor shall submit operation and maintenance manuals in accordance with the procedures and requirements of the Contract Documents.
2. Two copies of a preliminary O&M manual shall be included in the shop drawing submittal. Without inclusion of these manuals, the submittal will be considered incomplete and will be returned without review.

E. Lubricants

1. The manufacturer shall submit a list with a minimum of four manufacturer's standard lubricants which may be used interchangeably for each type of lubricant required.
2. The Contractor shall utilize this list in preparing his comprehensive lubrication survey.

1.06 QUALITY ASSURANCE AND QUALIFICATIONS

- A. The equipment covered by these Sections shall be standard equipment of proven performance as manufactured by reputable concerns. Equipment shall be designed, constructed and installed in accordance with the best practices of the

## GENERAL SPECIFICATION 15760 - UNIT HEATERS - HOT WATER

---

trade, and shall operate satisfactorily when installed as shown on the Contract Drawings.

- B. All components of the equipment specified in this section shall be provided by the Contractor through one vendor. The Contractor through the vendor shall have the sole responsibility of matching all components and providing equipment which functions together as a system.

### 1.07 SPARE PARTS

- A. Provide two sets of filters for each cabinet unit heater, properly packed and labeled.
- B. Provide one motor for up to every 4 of same size motor for all heaters.

## PART 2 PRODUCTS

### 2.01 UNIT HEATERS

#### A. Manufacturers:

1. Trane Company, Long Island City, NY.
2. Modine Manufacturing Company, Racine, WI..
3. Or approved equal.

#### B. Materials:

1. The unit heater shall be complete with hot water coil, fan, motor, fan guard, louver fin diffuser for horizontal unit heaters and casing. Each unit shall be provided with mounting bracket.
2. The entire unit including coil shall be coated internally and externally with a corrosion resistant coating such as Heresite, Phenolic VR-500, or approved equal. The coating on the entire unit shall be baked on.
3. The coils shall be constructed of aluminum fins permanently bonded to seamless copper tubes. The coils shall be suitable for pressure up to 200 psig and entering water temperatures up to 325EF inclusive. Coils shall be tested at a minimum of 300 psig air pressure under water.
4. The casing shall be constructed of heavy gauge steel.
5. Fan wheels shall consist of heavy gauge aluminum propeller type blades, statically and dynamically balanced at the speed at which the unit is scheduled to operate.
6. The fan shall be direct driven by a resiliently mounted, single speed, totally enclosed motor. Explosion-proof motors shall be provided where indicated on the schedule or where required by Code.

2.02 CABINET HEATERS

A. Manufacturers

1. Trane Company, Long Island City, NY.
2. Modine Manufacturing Company, Racine, WI.
3. Or approved equal.

B. Materials: Provide cabinet heaters of the minimum size, heating and air capacities and arrangement shown, meeting the following requirements:

1. Provide units listed by the Underwriters Laboratories Inc.
2. Provide the heating element constructed of seamless copper tubes hydraulically expanded into aluminum plate fins to give a permanent bond.
3. Construct cabinets of heavy gauge bonderized sheet steel, with a baked enamel finish of a standard color selected. Construct front panels of die formed steel, with top inlet and bottom discharge grilles.
4. Construct blowers of aluminum, of the forward curved, centrifugal, double width, double inlet type, balanced to give quiet operation. Provide the permanent split capacitor type motor, 3-speed, with automatic overload protection and resilient base. Provide the motor of the direct drive type with lubricated bearings, and with the speed selector switch mounted inside the cabinet.
5. Provide units complete with 1 inch thick fiberglass disposable type air filters, arranged for easy removal and replacement.

2.03 SHOP TESTING

- A. All tests shall be performed in accordance with the requirements of this Contract. Certified Shop Tests: Test motors in accordance with General Specification 16221 - Electric Motors. Coils shall be tested at a minimum of 300 psig air pressure under water.

PART 3 EXECUTION

3.01 INSTALLATION

- A. Each unit of equipment shall be installed, connected and placed in satisfactory working order in accordance with the manufacturer's instructions and details, and the Contract Drawings.

3.02 IDENTIFICATION

- A. Each unit of equipment shall be identified as described in General Specification 15076 - Piping and Equipment Identification.

## GENERAL SPECIFICATION 15760 - UNIT HEATERS - HOT WATER

---

### 3.03 PAINTING

- A. All exterior and interior metal surfaces of unit heaters except coils, shall be factory primed and factory painted in accordance with General Specification 09900 - Painting.

### 3.04 FIELD TESTING

- A. Field tests shall be performed in accordance with General Specification 15951 - Testing, Adjusting and Balancing.

### 3.05 MANUFACTURER'S REPRESENTATIVE

- A. The Contractor shall provide the services of a qualified manufacturer's technical representative who shall adequately supervise the installation and testing of all equipment furnished under this Contract. The services of the manufacturer's representative shall be provided for a period of not less than 8 hours. Any additional time required to achieve successful installation and operation shall be at the expense of the Contractor.
- B. The manufacturer's representative shall sign in and out at the office of the Resident Engineer on each day he is at the project.
- C. Training
  - 1. The Contractor shall provide training for City personnel in accordance with the requirements of this Contract.
  - 2. The Contractor shall include in his request for manufacturer approval a certification that the manufacturer has been advised of the training requirements and that the costs associated with said training submittals and training have been included in the manufacturer's pricing.

### 3.06 ADJUSTMENTS

- A. Set air deflectors for proper air delivery.
- B. Check room thermostat and wiring connections to unit heater.
- C. Check return air thermostat and connections to cabinet unit heater.

### 3.07 CLEANING

- A. Clean tar, cement or other dirt from units.
- B. Remove debris and other waste material resulting from installation.

END OF SECTION

**SECTION 15761  
Heaters, Electric**

**PART 1 GENERAL**

**1.01 SECTION INCLUDES**

- A. The Contractor shall provide all labor, materials, equipment and incidentals as specified and required to furnish and install all electric heaters complete with auxiliary equipment and accessories as shown, specified and/or required for proper operation.
- B. Schedule: Units shall be furnished in accordance with the equipment data schedules as shown on the Contract Drawings.
- C. Index:

<u>Article</u>	<u>Title</u>	<u>Page</u>
		15761-
PART 1	GENERAL .....	1
1.01	Section Includes .....	1
1.02	Related Sections .....	1
1.03	Payment .....	2
1.04	References .....	2
1.05	Submittals .....	2
1.06	Quality Assurance .....	2
1.07	Spare Parts .....	3
PART 2	PRODUCTS .....	3
2.01	Unit Heaters .....	3
2.02	Electric Duct Heaters (Edh) .....	9
2.03	Convection/Radiation Heaters .....	12
2.04	Electric Baseboard Heaters .....	13
PART 3	EXECUTION .....	13
3.01	Inspection .....	13
3.02	Installation .....	14
3.03	Painting .....	14
3.04	Cleaning .....	14
3.05	Adjustments .....	14

**1.02 RELATED SECTIONS**

- A. Section 09900 - Painting
- B. Section 15951 - Testing, Adjusting and Balancing

1.03 PAYMENT

- A. Payment for work furnished and installed under this Section shall be as specified in the Contract Documents.

1.04 REFERENCES

- A. Reference Standards: Comply with applicable provisions and recommendations of the following, except as otherwise shown or specified. General requirements of this Contract shall supersede the Standards in case of conflict:
  - 1. Air Moving and Conditioning Association (AMCA)
  - 2. American Society of Heating, Refrigerating, and Air Conditioning Engineers (ASHRAE)
  - 3. National Electrical Manufacturers' Association (NEMA)
- B. Where reference is made to one of the above standards, the revision in effect at the time of bid opening shall apply.

1.05 SUBMITTALS

- A. Contractor shall submit Shop Drawings and material specifications for the approval of the Engineer. Submittals shall include, but not be limited, to the following:
  - 1. Dimensions.
  - 2. Capacities.
  - 3. Materials of construction.
  - 4. Finishes, standard and custom color chart for Engineer's approval.
  - 5. Manufacturer's literature, illustrations, Specifications and engineering data.
  - 6. Documentation from the factory substantiating painting systems in accordance with the specifications. Include types applied and dry film thicknesses.
- B. Operations and Maintenance Manuals:
  - 1. The Contractor shall submit operation and maintenance manuals in accordance with the procedures and requirements of this Contract.
  - 2. Two copies of a preliminary O&M manual shall be included in the shop drawing submittal. Without inclusion of these manuals, the submittal will be considered incomplete and will be returned without review.

1.06 QUALITY ASSURANCE

- A. Manufacturer Qualifications:



1. Engage a single firm, with undivided responsibility for performance, fabrication, and other requirements.
2. The equipment covered by this Section is intended to be standard equipment of proven performance as manufactured by reputable concerns. Equipment shall be designed, constructed and installed in accordance with the best practices of the trade, and shall operate satisfactorily when installed as shown on the Contract Drawings.

**B. Contractor's Qualifications:**

1. Contractor shall have at least 5 years' experience in the installation of the Work specified. He shall employ only tradesmen with specific skills and experience in this type of Work.
2. Contractor shall have undivided responsibility as a single firm for performance and other requirements for the installation of equipment specified herein.

**C. Requirements of Regulatory Agencies: Comply with applicable provisions of regulatory agencies below and others having jurisdiction.**

1. Underwriters Laboratories, Incorporated (UL).
2. National Fire Protection Association (NFPA).
3. National Electrical Code (NEC).
4. Local and State Building Codes and Ordinances.
  - a. New York City Building Code.
  - b. New York State Uniform Fire Prevention and Building Code.
  - c. New York State Energy Conservation Construction Code.

**D. UL Listing: All heaters and appurtenances shall be UL listed.**

**1.07 SPARE PARTS**

- A. Provide one can of touch up paint, one quart size for each type of heater.
- B. Provide two (2) sets of spare filters for each cabinet heater.
- C. Provide one (1) motor for up to every four of same size motors for all heaters.

**PART 2 PRODUCTS**

**2.01 UNIT HEATERS**

**A. Electric Unit Heaters:**

1. Electric unit heaters shall be as manufactured by:
  - a. Chromalox Model LUH, Trane Co., Long Island, City, NY.

## GENERAL SPECIFICATION 15761 - HEATERS, ELECTRIC

---

- b. Or approved equal.  
The unit heaters shall be complete with casing, element, fan, motor, fan guard, and factory-wired controls.
  2. Casing shall be constructed of minimum 18 gauge steel and finished in high gloss, baked enamel. Adjustable discharge louvers shall be provided to control the direction of air flow. Each unit shall be provided with mounting brackets.
  3. Element shall be of the high mass, all steel, tubular finned type.
  4. Fan shall be of the axial flow type and shall be statically and dynamically balanced at the speed at which the unit is scheduled to operate. The fan shall be direct driven by a single speed, totally enclosed motor with internal thermal overload protection.
  5. Contactors and Control Circuit Transformers shall be factory installed and wired. Two stage operation shall be provided on all units. Each unit shall be complete with wall mounted thermostat and with hand-off-auto subbase. Built in fan override shall be provided to purge unit casing of excess heat after unit shut down.
  6. Each unit heater shall have a corrosion resistant coating. The entire unit shall be coated internally and externally with baked on heresite, phenolic VR-500 or approved equal corrosion resistant coating.
  7. Each unit heater shall be provided with mounting brackets.
  8. Unit heaters shall be furnished in accordance with the schedule shown on the Contract Drawings.
- B. Explosion-Proof Unit Heaters:
1. Manufacturer: Provide products as manufactured by:
    - a. Industrial Engineering and Equipment Company (INDEECO), Saint Louis, MO - Series 236 Compact Explosion-proof unit heater.
    - b. Or approved equal.
  2. Reference: Suitable for use in a National Electrical Code, Class 1, Division 1, Group D environment and NEC T-1. Factory Mutual approved.
  3. Casings:
    - a. Material: Housing to be minimum 18 gage Type 316 stainless steel shroud and cast iron terminal enclosure with bottom access cover. Epoxy coated enclosure, fan blade conduit and fittings.

## GENERAL SPECIFICATION 15761 - HEATERS, ELECTRIC

---

- b. Supports, Type 316 stainless steel swivel bracket for wall mounting, furnished by unit heater manufacturer. Stainless steel hardware.
4. Heating Element: Type 316 stainless steel, finned tubular construction.
5. Fans:
  - a. Type: Broad blade axial flow-type design.
  - b. Construction: Aluminum.
  - c. Dynamically balanced.
6. Motors:
  - a. Type: Single speed.
  - b. Enclosure: Totally enclosed-explosion-proof.
  - c. Mounting: resilient mounted.
  - d. Bearings: Permanently lubricated, sealed bearings.
  - e. Overload Protection: Provide integral overload protection.
  - f. Power: As shown on the Contract Drawings.
  - g. Produced in accordance with NEMA standards.
  - h. Factory wired to enclosure.
  - i. Suitable for 40°C ambient temperature.
7. Air Deflectors: Outlet grilles shall be louvered for 45 degree throw (adjustable), stainless steel.
8. Built-in controls: Element terminals, thermal cutouts, manual reset cut out, controlling and back-up contactors and fan delay relay shall be housed in a NEMA 7 enclosure.
9. Capacity: As shown on the Drawings.
10. Explosion-Proof Room Thermostat:
  - a. UL Listed for Class I, Group D hazardous locations. Explosion proof Construction.
  - b. Complete with built-in thermometer.
  - c. 40°F to 100°F Range with 1°F differential.
  - d. Tamperproof set point locking device.
  - e. Rating: 120 volt AC, 125 VA rating.
  - f. Manufacturer:
    - 1) INDEECO, Saint Louis, MO, Model C251-011.

- 2) Or approved equal.
11. Controls:
  - a. Explosion proof room thermostat, field wired to unit heater to control heater operation set at 55°F (adjustable) or as required.
  - b. A complete wiring diagram shall be submitted indicating both factory and field connections.
- C. Corrosion Resistant Unit Heater:
  1. Description:
    - a. Minimum 18 gauge epoxy painted steel.
    - b. Stainless steel swivel wall mounting bracket.
    - c. Monel fin tube heating elements attached to junction box with leak proof threaded fittings. All sheet metal parts protected by zinc chromate primer and 2 coats of epoxy enamel, all factory painted.
    - d. Integral NEMA 4X molded fiberglass junction box for all unit mounted controls, as listed below.
    - e. Motor:
      - 1) Totally enclosed with permanently lubricated ball bearings.
      - 2) Thermal overload protection built-in. Moisture and corrosion resistant automatic reset.
    - f. Fan:
      - 1) Aluminum spark resistant construction.
      - 2) Painted with one coat zinc chromate primer and two coats corrosion resistant epoxy paint.
    - g. Adjustable louvered outlet grille, finish same as fan.
    - h. Heavy gauge rear wire grille, finish same as fan.
    - i. All hardware shall be stainless steel.
  2. Controls: Heating elements, motor and cutout to be factory prewired to junction terminal block for easy hook-up. Furnish all controls (thermostat, relay, transformer etc.) for field installation as necessary for control operation.
    - a. Built-in:
      - 1) Two power contactors, primary and backup.

## GENERAL SPECIFICATION 15761 - HEATERS, ELECTRIC

---

- 2) Motor contactor.
- 3) Over temperature protection.
- 4) Thermal fan delay switch.
- b. Provide transformer for 120 V control circuit.
- c. Room Thermostat: Field Installed:
  - 1) Wall mounted corrosion resistant thermostat.
    - a) Heavy duty line voltage SPDT, 120V, single phase.
    - b) Range: 40° to 100°F.
    - c) Weatherproof NEMA 4X.
    - d) Shielded sensing bulb.
    - e) Neoprene gasket to seal out dust and moisture.
    - f) Adjustable knob for temperature setting.
    - g) Positive off by setting unit to low position.
      - (1) Chromalox, Pittsburgh, PA, Model WCRT-100.
      - (2) Or approved equal.
  - d. Unit mounted, factory installed thermostat where indicated on the Contract Drawings.
3. Capacity: As indicated on Contract Drawings.
4. Manufacturer:
  - a. Chromalox, Pittsburgh, PA, Model HDH (Hose Down Electric Heater).
  - b. Or approved equal.
- D. Cabinet Unit Heaters:
  1. Cabinet:
    - a. Construction: Front panel 16 gauge, top and side panels 18 gauge steel.
    - b. Finish: Phosphate treated, baked enamel.
  2. Heating Elements (Electric):
    - a. Material: Open wire type, Nichrone alloy element design.
    - b. Type: Resistance heat.

## GENERAL SPECIFICATION 15761 - HEATERS, ELECTRIC

---

- c. Electric Heating Coils: Hydronic type finned-tube construction with resistance elements inserted in tubes on 200-600 cfm units; spiral sheath type on 800-1800 cfm units.
    - d. Units factory wired with unit mounted heat switch, magnetic contactors, high temperature cutout safety control, and fan override thermostat.
  - 3. Fans:
    - a. Type: Forward curved centrifugal, double width, double inlet.
    - b. Material: Aluminum.
    - c. Mounting: Resilient on die-formed steel board.
  - 4. Motor:
    - a. Type: 2 speed, shaded pole.
    - b. Mounting: Resilient mounted.
    - c. Bearings: Permanently lubricated.
    - d. Overload Protection: Provide integral overload protection and motor starter.
    - e. Extended motor oilers.
  - 5. Filter: One inch thick throw away type mounted in filter frame.
  - 6. Controls:
    - a. Single heat switch and motor switch (heat-off-vent) with unit mounted transformer and integral thermostat all factory installed by unit manufacturer.
    - b. Wall mounted thermostat for field wiring where indicated on the Contract Drawings.
  - 7. Capacity: As shown on the Drawings.
  - 8. Manufacturer:
    - a. Trane Company, Long Island, NY.
    - b. Or approved equal.
- E. Wall Heater:
  - 1. Type: Recessed mounted, down-flow, all internally wired automatic unit.
  - 2. Construction:
    - a. Wall Box: 20 gage steel, phosphatized and baked enamel finish.

- b. Face Plate:
  - 1) Ribbed 16-gauge steel front cover.
  - 2) Closely spaced downflow discharge louvers.
  - 3) Concealed screws for locking trim frame to front cover.
  - 4) Finished in neutral gray baked enamel with satin finish anodized aluminum trim frame.
- c. Element: Cast aluminum heating grid or metal sheathed heating element.
- 3. Fan: Broad blade, stamped metal, bolted to motor shaft.
- 4. Thermostat: Integrally mounted. Built-in thermostat comfort control with adjustment range between 55°F and 85°F, and manually set "No Heat" position. Tamper resistant adjustment by inserting screwdriver through front cover louvers.
- 5. Motor:
  - a. Type: Single speed.
  - b. Enclosure: Totally enclosed.
  - c. Bearings: Permanently lubricated.
  - d. Overload Protection: Provide integral overload protection.
  - e. Produced, tested and rated in accordance with NEMA standards.
- 6. Automatic reset line voltage internal thermal overload protection.
- 7. Built-in fan delay switch.
- 8. Line power terminal blocks for field power wiring connections.
- 9. Fan and motor assembly statically and dynamically balanced.
- 10. Transformer: Built-in, if required.
- 11. Heating Capacity: As shown on the Drawings.
- 12. Manufacturer:
  - a. Q-Mark, Bennettsville, SC, Marley Electric Heating.
  - b. Or approved equal.

2.02 ELECTRIC DUCT HEATERS (EDH)

- A. Product and Manufacturers: Provide completely factory assembled and wired units as manufactured by one of the following:
  - 1. INDEECO, Saint Louis, MO.
  - 2. Electroduct, Brasch Manufacturing Company, Paris, MO.

## GENERAL SPECIFICATION 15761 - HEATERS, ELECTRIC

---

3. Or approved equal.
- B. Capacity and electrical supply characteristics shall be as scheduled on Drawings.
- C. Construction:
1. Framing for duct heater shall be flanged for internally insulated duct, slip-in type if external insulation is used.
  2. Duct heater frame shall be reinforced with needed corner bracing.
  3. Insulation of fiberglass at least 1/2-inch thick shall be used between duct heater and control box for maximum condensation protection.
  4. Heaters shall be constructed per U.L. standards for zero clearance and shall meet NEC requirements.
  5. Heating elements shall be finned tubular Type 301 or 304 stainless steel with internal resistance wire of 80% nickel and 20% chromium; steps shall be arranged to prevent stratification when operating at less than full capacity.
  6. Provide insulated element terminals.
  7. Frame shall be constructed of minimum 16 heavy gauge stainless steel with stainless steel brackets, stiffening ribs and gussets spot welded to the casting.
  8. Terminal box shall be spot welded construction with solid, hinged cover, totally enclosed, without louvers or grilles per UL Standard 1096. NEMA 4X stainless steel.
  9. Three phase heaters shall be furnished with balanced phases on each step.
  10. Elements shall be rated approximately 50 watts per square inch of wire surface area.
  11. Air flow sensing tube for air flow proving switch shall indicate direction of air flow and be field reversible without removing heater from duct.
  12. Disc type automatic reset thermal protection shall be provided as the primary protection and shall be mounted on the duct heater directly in the air stream to provide positive, fast response.
  13. Provide secondary manual limit-type reset thermal protection in control circuit in series with automatic.
  14. Heaters shall be electrically tested at 1,000 volts if rated at 250 volts or less and 1,000 volts plus twice the rated voltage if rated at more than 250 volts.



## GENERAL SPECIFICATION 15761 - HEATERS, ELECTRIC

---

15. All heaters shall be tested at manufacturing facilities for assurance of high quality standards and performance by trained personnel. All components shall be tested for function following installation in the heater.
  16. Wiring Diagrams: A wiring diagram shall be furnished for each type of heater. Diagram shall include recommended supply wire gauges in conformance to the NEC and fuse sizes. Typical wiring diagrams are not acceptable.
- D. Duct Size: Shall be as scheduled on Drawings.
- E. Step Controller (3 or more heating stages as scheduled):
1. Type: Electronic.
  2. Steps: Shall be as scheduled on Drawings.
  3. Input: 0 to 135 ohm.
  4. Step controller shall cycle to 0 load if a momentary power interruption occurs.
- F. Thermostat (Space):
1. Wall mounted room thermostat for field wiring.
  2. Refer to Paragraph 2.01C.2 of this Section.
- G. Pilot Lights: Built-in, factory wired, transformer coupled, 6-volt lamped pilot lights shall indicate the following conditions:
1. Heater Energized.
  2. Step Energized: 1 per step.
  3. When built-in-air flow switch opened.
- H. Proof of Air Flow Switch:
1. In accordance with UL Standard 1096.
  2. Type: Pressure differential switch.
  3. Shall deactivate unit and deenergize heating element if proper air flow is not present.
- I. Built-in Options:
1. Non-mercury Control Contactors.
  2. Main Power Disconnect Switch.
  3. Interlock terminal strip for interlocking supply air fan.
  4. Control Transformers with Fused Primaries for 120 VAC and 24 VAC circuits.

- J. Unit Mounted Control Enclosure: Standard control box shall be of the hinged, solid cover type, NEMA 4X (NEMA 7 in NFPA classified explosion proof area) stainless steel construction.

2.03 CONVECTION/RADIATION HEATERS

- A. Type: Sill Line Radiation: Wall mounted electric, convection heaters, completely factory wired with integral thermostat, end caps and filler or blank sections shall be included.

- B. Capacity: As specified on the Contract Drawings.

- C. Cabinet:

1. 16 gage steel enclosure with reinforced all welded construction.
2. Enclosure chemically treated to resist corrosion and finished in grey prime suitable for field finish.
3. Top discharge to be an extruded aluminum bar grille with protective 1/4-inch mesh screen below grille.
4. Bottom air inlet perforated openings.
5. Back surface of heater, filler and blank section enclosure to be completely smooth, except for electrical knockouts and mounting holes.
6. Bottom of front cover fastened to back panel with concealed screws and top of front cover to engage with grille supports.
7. Sleeve, end cap and corner accessories to be internal telescoping type, mounted to concealed top and bottom sliding set screw fasteners in end of sill line heaters, filler or blank sections and finished in dark baked enamel.
8. Back panel slotted along top and bottom for attachment to wall or window mullions without removal of heating assembly.
9. Filler and blank section accessories to be of same cross-section as sill line heater enclosure, with butt-joint ends. 8-inch filler section to have hinged access door.
10. All heaters and electrical accessories to be labeled by Underwriters Laboratories, Inc.

- D. Elements:

1. Heating elements shall be aluminum.
2. Elements shall be center anchored and shall float freely on each end through nylon bushings.

E. Controls:

1. Factory installed built-in controls shall include thermostat, power disconnect switch, transformer relay, etc. Wall mounted thermostat for field wiring where shown on the Contract Drawings.
2. Thermostats shall be adjustable through discharge louvers.
3. An automatic reset thermal overload protector with automatic reset shall run the full-length of the heater and shall turn off heating elements should overheating occur at any point along heating length.

F. Manufacturer:

- a. Q-Mark, Bennettsville, SC, Marley Electric Heating.
- b. Trane Company, Long Island City, NY.
- c. Or approved equal.

2.04 ELECTRIC BASEBOARD HEATERS

- A. Electric baseboard heater shall meet the minimum size, heating capacities and arrangement shown and scheduled on the Contract Drawings.
- B. The enclosure shall be of heavy gauge steel with baked on enamel finish of a color selected from the manufacturer's color charts.
- C. The electrical components shall be factory prewired to a terminal strip. All controls including thermostat shall be unit mounted and factory installed.
- D. Each baseboard heater shall be comprised of aluminum finned metal sheath heating elements, a built-in thermostat and an automatic reset thermal overload cutout.
- E. Electric baseboard heaters shall be complete with bottom inlet and top discharge grilles and shall be wall mounted as shown on the Drawings.
- F. Heaters shall be listed by the Underwriters Laboratories, Inc. and meet the requirements of the National Electric Code.
- G. Heaters shall be as manufactured by
  - a. Trane Company, Long Island, City, NY.
  - b. Chromalox, Pittsburgh, PA.
  - c. Q Mark, Bennettsville, SC.
  - d. Or approved equal.

PART 3 EXECUTION

3.01 INSPECTION

- A. Inspect units for damage prior to installation and correct as necessary.

3.02 INSTALLATION

- A. Unit heaters shall be installed, connected and placed in satisfactory working order in accordance with the manufacturer's instructions and details, and the Contract Drawings.
- B. Each unit of equipment shall be identified with the equipment item numbers given on the Contract Drawings. A corrosion resistant tag or nameplate, securely affixed in a conspicuous place on each unit shall give the equipment item number, manufacturer's name or trademark and such other information as the manufacturer may consider necessary, or as specified, to complete identification.
- C. Install cabinets level and plumb.
- D. Install units in accordance with details on the Drawings and approved Shop Drawings.
- E. Coordinate with ceiling grid for ceiling recessed units installation.

3.03 PAINTING

- A. All exterior and interior metal surfaces of unit heaters except coils, shall be factory primed and factory painted in accordance with Section 09900, -, Painting.

3.04 CLEANING

- A. Clean tar, cement or other dirt from units.
- B. Remove debris and other waste material resulting from installation.

3.05 ADJUSTMENTS

- A. Conform to requirements of Section 15951 - Testing, Adjusting and Balancing.
- B. Set air deflectors for proper air delivery.
- C. Check room thermostat and wiring connections to heater.

END OF SECTION

**SECTION 15762 - FINNED TUBE RADIATION**

---

**SECTION 15762  
Finned Tube Radiation**

**PART 1 GENERAL**

**1.01 SECTION INCLUDES**

- A. The Contractor shall provide all labor, materials, equipment and incidentals as specified and required to furnish and install all finned tube radiation complete with auxiliary equipment and accessories as shown, specified and/or required for proper operation. The Contractor shall include as part of this work all supports required.
- B. The equipment shall be furnished complete with all accessories, special tools, spare parts, attachments, mounting, anchor bolts and other appurtenances as specified or as may be required for a satisfactory installation.
- C. Units shall be furnished in accordance with the schedule shown on the Contract Drawings.
- D. Index:

<u>Article</u>	<u>Title</u>	<u>Page</u>
		15762-
PART 1	GENERAL.....	1
1.01	Section Includes.....	1
1.02	Related Sections.....	1
1.03	Payment.....	2
1.04	References.....	2
1.05	Submittals.....	2
1.06	Quality Assurance And Qualifications.....	2
PART 2	PRODUCTS.....	3
2.01	Fin Tubes.....	3
PART 3	EXECUTION.....	3
3.01	Installation.....	3
3.02	Identification.....	3
3.03	Painting.....	3
3.04	Field Tests.....	4
3.05	Cleaning.....	4

**1.02 RELATED SECTIONS**

- A. Section 09900 - Painting
- B. Section 15076 - Piping and Equipment Identification

## SECTION 15762 - FINNED TUBE RADIATION

---

C. Section 15951 - Testing, Adjusting and Balancing

### 1.03 PAYMENT

A. Payment for work furnished and installed under this Section shall be as specified in the Contract Documents.

### 1.04 REFERENCES

A. Equipment shall comply with applicable provisions and recommendations of the following, except as otherwise shown or specified.

1. American Society of Mechanical Engineers (ASME).
2. American Society of Testing Materials (ASTM).
3. Standards of the Hydraulic Institute.
4. American National Standard Institute (ANSI).
5. National Fire Protection Association (NFPA).
6. Applicable Federal, State and local laws and/or ordinances.

B. Where conflict arises between the local codes and the requirements of the National Electrical Code, The National Fire Code, ASTM, etc., the more stringent requirements shall prevail.

### 1.05 SUBMITTALS

A. The Contractor shall obtain from the equipment manufacturer and submit Shop Drawings to the Engineer for approval. Submittals shall include, but not be limited, to:

- a. Equipment specifications and data sheets identifying all materials used and methods of fabrication.
- b. Complete assembly, layout, and installation drawing with clearly marked dimensions.

B. Operation and Maintenance Manuals

1. The Contractor shall submit operation and maintenance manuals in accordance with the procedures and requirements set forth in the Contract Documents.
2. Two copies of a preliminary O&M manual shall be included in the shop drawing submittal. Without inclusion of these manuals, the submittal will be considered incomplete and will be returned without review.

### 1.06 QUALITY ASSURANCE AND QUALIFICATIONS

A. The equipment covered by these specifications is intended to be standard equipment of proven performance as manufactured by reputable concerns. Equipment shall be designed constructed and installed in accordance with the

## SECTION 15762 - FINNED TUBE RADIATION

---

best practices of the trade, and shall operate satisfactorily when installed as shown on the Contract Drawings.

- B. All components of the Fin Tube System shall be provided by one vendor who shall have the sole responsibility of matching all components and providing equipment which functions together as a system.

### PART 2 PRODUCTS

#### 2.01 FIN TUBES

- A. Accepted as manufactured by:
  - 1. Slant Fin, Greenvale, NY
  - 2. Trane Co, Long Island City, NY.
  - 3. Vulcan Radiator Co, South Windsor, CT.
  - 4. Or approved equal.
- B. The heating elements shall consist of aluminum fins and copper tubing.
- C. Enclosure shall be complete with 14 gauge sloping or flat top enclosure with continuous grille, knob operated damper, full length mounting strips, enclosure brackets, element supports and access extensions. Access extensions shall be provided at all valves. In addition, all accessories such as end panels, inside and outside corners and enclosure extensions shall be provided to complete the installation. Enclosures shall be chemically cleaned and finished in baked enamel. Color charts shall be submitted to the Engineer for selection of colors.

### PART 3 EXECUTION

#### 3.01 INSTALLATION

- A. Fin tubes shall be installed, connected and placed in satisfactory working order in accordance with the manufacturer's instructions and details, and the Contract Drawings.

#### 3.02 IDENTIFICATION

- A. Each unit of equipment shall be identified as described in Section 15076 - Piping and Equipment Identification.

#### 3.03 PAINTING

- A. All exterior and interior metal surfaces of unit enclosures, shall be factory primed and factory painted in accordance with Section 09900 - Painting.

#### 3.04 FIELD TESTS

- A. All tests shall be performed in accordance with the requirements of this Contract. Field acceptance tests shall be performed in accordance with Section 15951 - Testing, Adjusting and Balancing.

## SECTION 15762 - FINNED TUBE RADIATION

---

### 3.05 CLEANING

- A. Clean tar, cement and other dirt from units.
- B. Remove debris and other waste material resulting from installation.

END OF SECTION



**SECTION 15810  
Ductwork and Duct Accessories**

**PART 1 GENERAL**

**1.01 SECTION INCLUDES**

- A. The Contractor shall provide all labor, materials, equipment and incidentals as shown, specified and required to furnish and install all ductwork complete with auxiliary equipment and accessories as shown, specified and/or required for proper operation.
- B. Index:

<u>Article</u>	<u>Title</u>	<u>Page</u>
		15810-
PART 1	GENERAL.....	1
1.01	Section Includes.....	1
1.02	Related Sections.....	1
1.03	Payment.....	2
1.04	References.....	2
1.05	Submittals.....	3
1.06	Quality Assurance.....	3
PART 2	PRODUCTS.....	4
2.01	Materials.....	4
2.02	Metal Ductwork.....	5
2.03	Ductwork Accessories.....	6
2.04	Registers, Grilles And Diffusers.....	11
PART 3	EXECUTION.....	15
3.01	Installation.....	15
3.02	Adjustment.....	18
3.03	Balancing.....	19
3.04	Cleaning.....	19
3.05	Painting.....	19
3.06	Construction And Material Schedule.....	19

**1.02 RELATED SECTIONS**

- A. Section09900- Painting.
- B. Section13862- Non-Metallic Ductwork.
- C. Section15060- Hangers and Supports.
- D. Section15951- Testing, Adjusting and Balancing.

## SECTION 15810 – DUCTWORK AND DUCT ACCESSORIES

---

### 1.03 PAYMENT

- A. Payment will be made as provided for in the Contract Documents.
- B. No direct payment will be made for painting, coating, lining, gaskets, harnesses, bolts, nuts and other appurtenances and material required to provide and assemble the lines; the cost thereof shall be included in the prices bid for ductile and cast iron pipe.

### 1.04 REFERENCES

- A. Reference Standards: Comply with applicable provisions and recommendations of the following, except as otherwise shown or specified. General requirements of this Contract shall supersede the Standards in case of conflict:
  - 1. American Society of Heating, Refrigerating and Air Conditioning Engineers (ASHRAE).
  - 2. NFPA 90A - Installation of Air Conditioning and Ventilation Systems.
  - 3. Sheet Metal and Air Conditioning Contractors National Association (SMACNA).
    - a. HVAC Duct Construction Standards.
    - b. Seismic Restraint Manual - Guidelines for Mechanical Systems.
    - c. 4. ASTM E437 Industrial Wire Cloth and Screens (Square Opening Series)
  - 4. 5. UL 555 - Fire Dampers.
  - 5. 6. UL 181 - Factory Made Air Ducts and Connectors.
- B. 7. UL 214 - Tests for Flame Propagation of Fabrics and Films. Contractor shall provide certification that all stainless steel accessories including screws, hangers, supports, etc. for stainless steel, and FRP ductwork are Type 316 stainless steel.
- C. Field Measurements: Take field measurements where required prior to installation to ensure proper fitting of Work.
- D. Where reference is made to one of the above standards, the revision in effect at the time of bid opening shall apply.

### 1.05 SUBMITTALS

- A. Contractor shall submit Shop Drawings and material specifications for the approval of the Engineer. Submittals shall include, but not be limited to:
  - 1. 1/4-inch scale duct layouts.
  - 2. Dimensions.

## SECTION 15810 – DUCTWORK AND DUCT ACCESSORIES

---

3. Details of construction.
  4. Details of installation, hanger details and spacing.
  5. Manufacturer's literature, illustrations, specifications and Engineering data.
  6. Registers, grilles and diffusers.
  7. Fire Dampers (UL Listed):
    - a. Closing mechanisms.
    - b. Fusible link operating temperature.
    - c. Installation details.
    - d. Access Doors.
  8. Flexible connections.
  9. Other technical data related to the specified material and equipment as requested by Engineer.
  10. Duct sealants.
  11. Air outlet schedule indicating room name and location of each outlet. Cross reference contract designation and manufacturer's model number or name.
- B. Test Reports: Submit the following test reports for approval where required.
1. UL Label, Fire Dampers.
  2. Volume Damper leakage tests from an AMCA approved testing laboratory.

### 1.06 QUALITY ASSURANCE

#### A. Manufacturer Qualifications:

1. Engage a single firm, with undivided responsibility for performance and other requirements and components of the ductwork.
2. Engage a firm which can show successful experience in the fabrication and erection for ductwork systems of scope and type similar to the required Work.

#### B. Installer Qualifications:

1. Contractor shall have at least 5 years' experience in the installation of the Work specified. He shall employ only tradesmen with specific skills and experience in this type of Work.

## SECTION 15810 – DUCTWORK AND DUCT ACCESSORIES

---

2. Contractor shall have undivided responsibility as a single firm for performance and other requirements for the installation of the Work specified herein.
- C. Requirements of Regulatory Agencies: Comply with applicable provisions of regulatory agencies below and others having jurisdiction.
1. Underwriters Laboratories, Incorporated (UL)
  2. National Fire Protection Association (NFPA).
  3. National Electrical Code.
  4. Local and State Building Codes and Ordinances:
    - a. New York City Building Code.
    - b. New York State Uniform Fire Prevention and Building Code.
  5. Permits: Contractor shall obtain and pay for all required permits, fees and inspections.

### PART 2 PRODUCTS

#### 2.01 MATERIALS

##### A. Metal Ductwork:

1. Stainless Steel (Type 316 stainless steel): All ductwork shall be constructed of Type 316 stainless steel except where specified or indicated on plans. All accessories, air outlets, hardware, and fasteners shall be Type 316 stainless steel unless otherwise noted.
2. Galvanized Steel (G90 Coating): Only where specified on Contract Drawings.
  - a. Air devices for galvanized ductwork shall be aluminum.
3. Aluminum (with 3003 ductwork H-14 alloy and temper): Only where specified on Contract Drawings.
  - a. Air devices and ductwork accessories for aluminum ductwork shall be aluminum.

#### 2.02 METAL DUCTWORK

##### A. General:

1. All work shall be constructed and installed properly in accordance with the recommendations given in the latest edition of the Sheet Metal & Air Conditioning Contractors National Association (SMACNA) HVAC Duct Construction Standards and Rectangular Industrial Duct Construction Standards. All ductwork shall be constructed in accordance with the Schedule of Duct Construction Standards listed on

## SECTION 15810 – DUCTWORK AND DUCT ACCESSORIES

---

the last page of this section. The transverse duct connections shall be bolted, gasketed connections made with standard Ductmate 35 System as manufactured by:

- a. Duct Mate Industries Inc., Charleroi, PA.
  - b. Or approved equal.
2. All ducts shall conform accurately to the dimensions indicated on the Contract Drawings, shall be straight and smooth on the inside with neatly finished joints, and shall not be decreased at any point to avoid obstructions. No piping, conduit or structural work shall be installed in or through any ductwork. All ductwork shall be run as close as possible to structural members, walls and ceilings. Ductwork shall be as shown on the Contract Drawings, subject to such modifications as may be necessary to suit field conditions to clear any obstruction or conflicts with other equipment.
  3. Where existing walls, floors or roofs must be penetrated, Contractor shall neatly cut the required openings and patch the existing work to provide a neat and finished appearance.

### B. Stainless Steel Ductwork:

1. All ductwork shall be constructed of Type 316 stainless steel except where specified or indicated on the Drawings.
2. All stainless steel ductwork shall be shop fabricated in sections with welded flanged ends. No field welding of ductwork shall be permitted. Welding equipment and electrodes shall be of a type specifically suited for welding light gauge Type 316 stainless steel to provide consistently good quality welds. Stainless steel duct sheet thicknesses shall be two gauge heavier than the thickness specified in SMACNA standards for galvanized steel duct.
3. Flanged duct joints shall be 0.25-in Butyl gasketed and bolted together with stainless steel (Type 316) bolts, nuts, washers and lock washers. All duct joints shall be airtight.
4. All accessories including but not limited to, registers, grilles, diffusers, turning vanes, air turning devices, manual volume dampers, motor operated control dampers, fire dampers, and access doors installed in stainless steel ductwork shall be fabricated of the same stainless steel material as the associated ductwork. Supports, angles, clamps and hardware shall be Type 316 stainless steel.
5. Curbs to prevent water leakage shall be provided around all floor openings. Where concrete curbs are not indicated on the Contract Drawings, provide curbs fabricated of 4" x 4" x 1/4" thick angles with welded corners. The curb shall be set in a mastic compound and

## SECTION 15810 – DUCTWORK AND DUCT ACCESSORIES

---

securely fastened to the floor to provide a watertight installation. Curbs associated with stainless steel ductwork shall be fabricated of Type 316 stainless steel.

6. Schedule:
  - a. All ductwork shall be fabricated and installed in accordance with the Schedule listed at the end of this Section.
  - b. Duct constructed of fiberglass duct board shall not be permitted on the job except where specifically specified.

### 2.03 DUCTWORK ACCESSORIES

#### A. Hangers and Supports:

1. All ductwork shall be securely hung and anchored to the building structure. Unless otherwise shown or specified, hangers and stiffeners for ducts shall conform to the recommendations given in the SMACNA HVAC Duct Construction standards and SMACNA seismic restraint manual. Ducts shall be supported on trapeze hangers with angles or rods. Use of strap hangers and straps is prohibited.
2. All ductwork shall be supported from trapeze type hangers. Hanger rods shall be minimum 3/8 inch for all ducts with half perimeter up to 72 inches, and 1/2 inch diameter for all ducts with half perimeter larger than 72 inches. A pair of rods shall be provided at each duct support point. Maximum hanger spacing shall be 8 feet for ducts with half perimeter up to 72 inches and 6 feet for ducts with half perimeter larger than 72 inches.
3. All hangers, rods, supports, bolts, nuts, washers, inserts, and appurtenances shall be Type 316 stainless steel except for galvanized steel ductwork may be galvanized steel.
4. Hanger Construction and installation shall conform to SMACNA Standards, except as specified. No sheet metal duct hangers or straps will be allowed.
5. Support shall be furnished at each fitting.
6. Seismic Requirements: All piping and ductwork shall be provided with seismic restraints in accordance with the Seismic Restraint Manual, guidelines for Mechanical Systems dated 1991, as published by the Sheet Metal and Air Conditioning Contractors National Association, Inc. (SMACNA) and in accordance with the New York City Building Code and referenced Uniform Building Code requirements. Piping and ductwork shall be supported to withstand seismic forces anticipated in seismic zones 2A.
7. Conform to all requirements of Section 15060 - Hangers and Supports.

## SECTION 15810 – DUCTWORK AND DUCT ACCESSORIES

---

- B. Sleeves: Where ductwork passes through masonry walls, partitions or floors provide minimum 16 gauge, Type 316 stainless steel for stainless steel, FRP, and aluminum ductwork, and galvanized steel for galvanized ductwork. Caulk airtight with fire resistant sealant between sleeve and ductwork.
- C. Volume Dampers:
1. Reference: SMACNA Standards.
  2. Manufacturer: Provide dampers as manufactured by:
    - a. Ruskin Company, Grandview, MO.
    - b. Or approved equal.
  3. Material: As specified for ductwork.
  4. Blades: Opposed blades, vinyl edge seals.
  5. Provide outside handle, quadrant and approved position indicator and locking device.
  6. Performance:
    - a. Damper Leakage: Not more than 16 cfm per square foot at 4-inch W.G.
    - b. Certification: Manufacturer shall provide certified test data.
- D. Fire Dampers (Dynamic Type):
1. Fire Dampers:
    - a. Fusible Link Fire Dampers and access doors shall be installed where indicated on the Contract Drawings and where required by local codes. Fire dampers shall be of the curtain type with interlocking blades set in a one piece frame, and shall be suitable for installation in the vertical or horizontal position. The dampers shall conform to all requirements of the latest edition of the National Fire Code NFPA 90A and shall have a 1-1/2 or 4 hour standard fire protection rating in accordance with UL555, "Standard for Fire Dampers." Fire dampers installed in Type 316 stainless steel, aluminum, and fiberglass ductwork shall be fabricated of Type 316 stainless steel and shall be provided with vacuum formed springs. All fusible links shall be UL rated at 165°F.
    - b. Rectangular fire dampers shall be as manufactured by:
    - c. 1) Air Balance, Inc., Wyalusing, PA.
    - d. 2) Or approved equal.
    - e. Provide twelve (12) spare fusible links.

## SECTION 15810 – DUCTWORK AND DUCT ACCESSORIES

---

2. Reference: NFPA 90A, UL 555, SMACNA and local building codes.
3. Label:
  - a. All fire dampers shall have UL Label attached and galvanized steel construction for galvanized steel ductwork. Type 316 stainless steel construction for aluminum, stainless steel and FRP ductwork.
  - b. Label shall have a fire rating of minimum 1-1/2 hours for fire separations (walls, floors and partitions) rated at 2 hours. 3 hours for walls, floors and partitions rated at 3 hours and above.
  - c. All fire dampers shall be Dynamic Rated for closure against airflow in the following six installation configurations:
    - 1) Vertical Mount (Horizontal Airflow): Ducted and unducted.
    - 2) Horizontal Mount (Airflow Up): Ducted and unducted.
    - 3) Horizontal Mount (Airflow Down): Ducted and unducted.
  - d. Each fire damper proposed shall be rated to close against maximum design airflow at its installed location with a 10 percent safety factor and against 8 in. w.g. maximum pressure across the closed damper.
4. Two fire dampers rated at 1-1/2 hours each, one on each face of the fire separation or fire division, are required for fire separations having a 3-hour fire rating or above as per local code.
5. Type: Galvanized steel blades for galvanized ductwork and Type 316 stainless steel blades for aluminum, stainless steel and FRP ductwork with interlocking joints and fusible links.
6. Provide firestopping at fire separations where fire dampers are installed.
7. Provide an access door in duct at each fire damper located in duct.
- E. Sheet Metal Safing: Provide aluminum sheet metal safing to close off and seal airtight all unused areas behind louvers. Insulation shall be 2 inch thick fiberglass, permanently attached to sheet metal.
- F. Access Doors:
  1. Reference: SMACNA Standards.
  2. Type: Gasketed cam lock covers.
  3. Materials: Same as duct.
  4. Unless otherwise specified access doors shall be:



## SECTION 15810 – DUCTWORK AND DUCT ACCESSORIES

---

- a. 12 by 6 inches for ducts sizes 12-inches and smaller.
  - b. 12 by 12-inches for ducts size 14-inches.
  - c. 21 by 14-inches for ducts between 14 and 36 inches.
  - d. 25 by 17 inches for ducts between 36 and 60 inches.
  - e. Two 25 by 17 inch doors for ducts larger than 61 inches.
5. Access doors for fire dampers shall be stenciled "FIRE DAMPER ACCESS" with minimum ½-inch high letters.
- G. Flexible Connections:
1. Reference: SMACNA Standards for pressure classification of 3 inches water gage.
  2. Material (unless otherwise specified):
    - a. Minimum 1/16-inch thick, 6-inch wide reinforced butyl or EPDM sheeting.
    - b. 16 gauge, 3-inch wide galvanized steel strip for galvanized steel ductwork. Type 316 stainless steel for stainless steel ductwork.
    - c. 0.080 thick 3-inch wide aluminum strip for aluminum ductwork.
- H. Turning Vanes:
1. Reference: SMACNA.
  2. Construction: Same Material as ductwork.
  3. Vanes: Double thickness.
- I. Air Volume Extractors:
1. Reference: SMACNA.
  2. Manufacturer: Provide extractors manufactured by one of the following:
    - a. Hart and Cooley, Grand Rapids, MI
    - b. Titus, Plano, TX.
    - c. Or approved equal.
  3. Construction: Same Material as ductwork.
  4. Blades: Gang-operated curved adjustable blades controlled through manual adjusting lever.
- J. Gravity Backdraft Dampers (located in ductwork):
1. Construction:
    - a. Multiple, interlocked blades mounted in frame.

## SECTION 15810 – DUCTWORK AND DUCT ACCESSORIES

---

- b. Felt gasketed blade edges.
  - c. Stainless steel or brass bearings.
  - d. Tie rod connecting each blade.
  - e. Counterweights or adjustable spring attached to tie rods.
  - f. Metal frame.
2. Materials:
    - a. Same material as ductwork.
    - b. Tie Rod: Aluminum 0.081 gage.
    - c. Louver Arm: Aluminum 0.081 gage.
    - d. Bumpers: Waterproof felt.
- K. Hardware:
1. All fastening devices used for aluminum, stainless steel, and FRP ductwork shall be Type 316 stainless steel.
  2. All gasketing material shall be butyl.
- L. Metallic Flexible Duct:
1. Metallic type duct shall be single-ply Type 316 stainless steel. Duct shall be of corrugated/interlocked, folded and knurled type seam construction, bendable without damage through 180 degrees with a throat radius equal to  $\frac{1}{2}$  duct diameter.
  2. Duct shall conform to UL 181 and shall be rated for positive or negative working pressure of minimum 5 inches water gauge at 250°F.
  3. Runout length shall be limited to 10 feet and size limited to 8 inch in diameter.
- M. Insulated Nonmetallic Flexible Duct Runouts:
1. Flexible duct runouts shall be used only where indicated. Runout length shall be as shown on the Contract Drawings, but shall in no case exceed 10 feet in length and 8 inch in diameter. Runouts shall be pre-insulated, factory fabricated, and shall comply with NFPA 90A and UL 181. Either field or factory applied vapor barrier shall be provided.
  2. For round/oval ducts, the flexible material shall be secured by stainless steel or zinc-coated, iron clinch-type draw bands.
  3. For rectangular ducts, the flexible material locked to metal collars shall be installed using normal duct construction methods.
  4. The composite connector system shall comply with UL 214 and be classified as "flame-retarded fabrics" in UL-01.

## SECTION 15810 – DUCTWORK AND DUCT ACCESSORIES

---

- N. High Temperature Service Duct Connections: Material shall be approximately 3/32 inch thick, 35 to 40-ounce per square yard weight, and plain weave fibrous glass cloth with nickel/chrome wire reinforcement for service in excess of 1200°F.
- O. Air Vents and Goosenecks:
1. Air vents and goosenecks shall be fabricated from the material as specified for ductwork with structural shapes. Sheet metal thickness, reinforcement, and fabrication shall conform to SMACNA-06.
  2. Air vents and goosenecks shall be provided with bird screen.
- P. Bird Screens and Frames: (Type 316 Stainless Steel): Bird screens shall conform to ASTM E 437, Type I, Class 1, 2 by 2 mesh, [0.031 inch diameter stainless steel wire]. Frames shall be removable type stainless steel construction.
- 2.04 REGISTERS, GRILLES AND DIFFUSERS
- A. Manufacturer: Provide equipment as manufactured by:
1. A-J Manufacturing Co., Inc., Kansas City, MO.
  2. Carnes, Verona, WI.
  3. Tuttle & Bailey, Richardson, TX.
  4. Titus, Plano, TX.
  5. Or approved equal.
- B. General:
1. Units shall be factory-fabricated of Type 316 stainless steel construction for stainless steel and FRP ductwork; aluminum construction when installed in aluminum and galvanized steel ductwork, and shall distribute the specified of air volume (cubic feet per minute).
  2. Outlets for diffusion, spread, throw, and noise level shall be as required for specified performance. Performance shall be certified according to ASHRAE 70. Inlets and outlets shall be sound rated and certified according to ASHRAE 70.
  3. Diffusers and registers shall be provided with volume damper with accessible operator, unless otherwise indicated; or if standard with the manufacturer, an automatically controlled device will be acceptable. Volume dampers shall be opposed blade type for all diffusers and registers, except linear slot diffusers. Linear slot diffusers shall be provided with round or elliptical balancing dampers.
  4. Where the inlet and outlet openings are located less than 7 feet above the floor, they shall be protected by a grille or screen according to NFPA 90A.

## SECTION 15810 – DUCTWORK AND DUCT ACCESSORIES

---

5. Diffusers:
    - a. Diffuser types shall be as indicated. Diffusers shall be provided with air deflectors of the type indicated.
    - b. Air handling troffers or combination light and ceiling diffusers shall conform to the requirements of UL-03 for the interchangeable use as cooled or heated air supply diffusers or return air units.
    - c. Ceiling mounted units shall be installed with rims tight against ceiling.
    - d. Sponge rubber gaskets shall be provided between ceiling and surface mounted diffusers for air leakage control. Suitable trim shall be provided for flush mounted diffusers.
    - e. Return or exhaust units shall be similar to supply diffusers.
  6. Registers and Grilles:
    - a. Units shall be four-way directional-control type, except that return and exhaust registers may be fixed horizontal or vertical louver type similar in appearance to the supply register face.
    - b. Registers shall be provided with sponge-rubber gasket between flanges and wall or ceiling.
    - c. Grilles shall be as specified for registers, without volume control damper.
  7. An additional volume damper shall be installed in duct stub to each air outlet for balancing of air volume.
- C. Supply Registers: Supply registers shall be double deflection type, as manufactured by:
1. A-J Manufacturing Co., Inc., Kansas City, MO (Model SS250V).
  2. Or approved equal.
  3. Registers shall be complete with adjustable vertical face bars and a key operated opposed blade damper. Supply registers installed in stainless steel and FRP ductwork shall be of Type 316 stainless steel double deflection type complete with opposed blade stainless steel damper and aluminum construction when installed in aluminum or galvanized steel ductwork.
- D. Air turning devices shall be installed at all collar take-offs to supply registers. Air turning devices shall be as manufactured by:
1. AJ Manufacturing Co., Inc., Kansas City, MO.  
Model SS250V

## SECTION 15810 – DUCTWORK AND DUCT ACCESSORIES

---

2. Or approved equal.
  3. The air turning devices shall have two sets of individually adjustable blades to equalize flow and control volume at collar takeoffs and shall be gasketed around the perimeter.
- E. Exhaust and return registers shall be as manufactured by:
1. AJ Manufacturing Co., Inc., Kansas City, MO
  2. Model SS550H.
  3. Or approved equal.
  4. Registers shall be complete with fixed vertical face bars, set straight, and a key operated opposed blade damper. Return and exhaust registers and damper installed in stainless steel and FRP ductwork shall be of Type 316 stainless steel with opposed blade stainless steel damper and aluminum when installed in aluminum or galvanized steel ductwork.
- F. Exhaust and return grilles shall be as manufactured by:
1. AJ Manufacturing Co., Inc., Kansas City, MO (Model SS550H).
  2. Or approved equal.
  3. Exhaust shall be complete with fixed vertical face bars, set straight. Return and exhaust grilles installed in stainless steel and FRP ductwork shall be of Type 316 stainless steel construction, and aluminum when installed in aluminum and galvanized steel ductwork.
- G. Supply diffusers shall be square plaque type, with round necks and integral volume dampers. They shall be as manufactured by:
1. AJ Manufacturing Co., Inc., Kansas City, MO (Model SSLCD).
  2. Or approved equal,
  3. And shall be entirely fabricated of Type 316 stainless steel construction when installed in stainless steel or FRP ductwork and aluminum construction when installed in aluminum or galvanized steel ductwork. Where required, and as indicated on the Contract Drawings, the Contractor shall provide blank off baffles to eliminate drafts caused by nearby obstructions. Diffuser face shall be 24" x 24" except where indicated different size on plans. Diffusers installed in hung ceilings shall be provided with anti-smudge ring.
- H. Supply Air Drum Louvers:
1. Supply air drum louvers shall be with a felt seal around the rotating drum to prevent leakage. The louver shall be adjustable to direct the air stream at any angle up to 30 degree from the louver centerline either by

## SECTION 15810 – DUCTWORK AND DUCT ACCESSORIES

---

rotating the drum or by adjusting the position of the pivoted vanes. Drum louvers shall be as manufactured by:

2. Krueger-HVAC, Richardson, TX (Series DPL).
  3. Or approved equal.
  4. Materials:
    - a. Stainless steel construction in stainless steel ductwork.
    - b. Aluminum in construction aluminum and galvanized steel ductwork.
- I. Transfer Grille Assembly: Wall mounted grilles shall consist of two (2) grilles, installed flushed to each side of wall. A fire damper shall be installed between the grilles when located in fire rated walls. The fire damper shall consist of a fully adjustable, key operated opposed blade damper with a spring loaded fusible link assembly Type 316 stainless steel construction. The fusible link shall be UL rated at 160F. The entire assembly shall conform to the latest edition of the National Fire Code No. 90A. All transfer grille assembly shall be Type 316 stainless steel. Transfer grilles shall be as manufactured by:
1. A.J. Manufacturing Co., Inc., Kansas City, MO.
  2. Or approved equal.
- J. Linear Bar Diffusers:
1. Linear bar diffusers shall be Model CT-580, as manufactured by:
    2. a. Titus, Plano, TX.,
    3. b. Or approved equal.
  4. With 1/8 inch thick fixed bars at 0 degree deflection, spaced 1/2 inch on center, or approved equal. Linear bar diffusers shall be available in standard one-piece lengths up to 6 feet and shall have the sizes and mounting types shown on the plans. Diffuser lengths greater than 6 feet shall be furnished in multiple sections and will be joined together end-to-end with alignment strips or pins to form a continuous appearance. All alignment components shall be provided by the manufacturer.
  5. The diffuser core shall have extruded aluminum bars locked into a heavy extruded aluminum border. The deflection bars shall be fixed and parallel to the long dimension. The core shall have support bars located no more than 9 inches apart and shall be parallel to the short dimension.
  6. Heavy gauge extruded aluminum end borders and mitered corners shall be available to close off the ends of the diffusers. Opposed blade damper shall be constructed of heavy gauge aluminum. Damper must be operable from the face of the diffuser.

**PART 3 EXECUTION**

**3.01 INSTALLATION**

- A. Turning vanes shall be installed in all miter elbows to permit air to make the abrupt turns with a minimum of turbulence. The turning vanes shall be quiet and free from vibration when the system is in operation. Turning vanes shall be double thickness type. Vanes shall be installed in all short radius elbows in accordance with SMACNA standards and Industrial Duct Construction standards. Duct clean out doors shall be provided at each elbow with turning vanes.
- B. Manual volume dampers larger than 11" in any dimension shall be opposed blade type. The damper blades shall be operated by a lockable dial regulator and may be set in any position. The dial regulators shall be marked so that the "open" and "shut" positions are clearly identified. The dial regulators on insulated ductwork shall be mounted on an elevated platform which will finish flush with the surface of the insulation. Manual volume dampers shall be located at accessible points and wherever possible some distance from a duct transition or fitting. Care shall be taken during installation to make certain that sheet metal fasteners do not protrude into the duct and interfere with damper operation. Dampers shall be provided in each branch duct take off and in both ducts downstream of each trunk duct split. Manual volume dampers shall be Type 316 stainless steel construction in stainless steel ductwork and aluminum construction in aluminum and galvanized steel ductwork.
- C. Splitter type dampers shall not be installed.
- D. Duct access doors shall be provided within working distance of, and on the fusible link side of all fire dampers, adjacent to volume dampers, on the linkage side of automatic dampers and at all other apparatus requiring service or inspection in the duct system. The doors shall be rigid and airtight, and provided with neoprene gaskets, hinges and sash locks. Whenever space requirements are such that a hinged access door is impractical, a screw fastened lift-out door shall be provided instead.
- E. Access doors in finished work such as walls, plaster, wood paneling and in suspended ceilings which do not have removable panels, shall be provided for all concealed valves, controls, test openings, duct access doors, and at all other locations requiring service, inspection or adjustment of a concealed item. The Contractor shall submit details of construction and material to the Engineer for review. In general, the access doors shall match the appearance of the finished work in which they are installed and shall be of sufficient size to permit service, inspection or adjustment of the concealed item.
- F. Test openings shall be installed in the ductwork at the points listed below. The openings shall be sealed by a screw cap and gasket, and shall be installed so that the insulation is not disturbed when the cover is removed. The test openings shall be located as follows in all heating, ventilating, air conditioning systems:

## SECTION 15810 – DUCTWORK AND DUCT ACCESSORIES

---

1. In the outside air duct adjacent to the unit.
  2. In the exhaust air duct adjacent to the unit.
  3. In the main supply duct on each unit.
- G. Flexible connections for preventing the transmission of vibrations through the ductwork to the structure shall be installed between the ductwork and all air moving equipment and at the building joints. Flexible connections shall be neoprene-impregnated fabric collars with cemented seams fastened with straps and bolts of the same material as the ductwork. Flexible connections shall not be painted or used to correct misalignment.
- H. The fire damper shall be secured to a stainless steel collar with ¼" diameter stainless steel nuts and bolts with maximum spacing of 12 inches on center and a minimum of two fastenings per side beginning two inches from the corners of the collar. The collars shall be at least the same gauge as the ductwork to which it is attached; regardless of the duct gauge, collars shall not be lighter than 24 gauge 316 stainless steel. Retaining angles shall be installed on four sides of the collar and on both sides of the protected opening with a minimum of one inch overlap on the wall or floor. The 316 stainless steel angles shall be a minimum of 1½" x 1½" x 1/8" and shall be fastened to the collar only; do not fasten angles to the wall or floor.
- I. The angles shall be fastened to the collar with ¼" diameter stainless steel nuts and bolts with a maximum spacing of 6 inches on center and a minimum of two fastenings per side beginning two inches from the corners of the collar. Where gas tight seals are required, the angles shall be fastened to the collar with a continuous weld and a sealant shall be installed between the angle and the wall or floor. Collars, angles and hardware used with stainless steel fire dampers shall be Type 316 stainless steel. Clearance for expansion is required between the collar and the opening on the top and on each vertical side. The clearance shall be 1/8 inch per lineal foot of sleeve with clearance on the sides distributed equally and all vertical clearance on the top. The retaining angles shall be increased in size to provide the minimum overlap of one inch on the wall or floor. The ductwork shall be connected to the collar on each side of the wall or floor with a breakaway connection on all four sides of the collar. The distance from the wall or floor to the breakaway connection shall not exceed 6 inches.
- J. Selfacting dampers shall be of the adjustable, counter-balanced type and shall be fabricated blades set in frame. Dampers and frames installed in the stainless steel ductwork when located shall be of Type 316 stainless steel and aluminum in aluminum and galvanized steel ductwork.
- K. Prefabricated roof curbs shall be installed first before the installation of roofing.



## SECTION 15810 – DUCTWORK AND DUCT ACCESSORIES

---

- L. Contractor shall furnish and install sleeves for registers, grilles, and dampers mounted in the masonry, concrete plenums or shafts. Sleeves shall be 16 gage Type 316 stainless steel.
- M. After the installation is completed, the Contractor shall seal all joints air tight. Sealants and tape shall have a flame spread not greater than 25 and a smoke developed rating of not over 50.
- N. Safing shall be provided to seal off remaining portions of shafts and louvers which are not covered by the plenums or equipment attached to the shaft or louver. Safing shall consist of a two inch thick rigid fiberglass board type insulation sandwiched between two 16 gauge minimum sheets. Insulation shall be secured to the sheets with adhesive. All edges of the panels shall be provided with a 16 gauge minimum channel secured in place with sheetmetal screws six inches on centers. Insulated sandwich panels shall be removable type with maximum space of 18 inches, and supported on 3 x 3 x ¼" angle. Provide intermediate supports. The sheets, channels and hardware used for the safing shall be 316 stainless steel. The Contractor shall submit details of construction to the Engineer for review.
- O. All screens shall be Type 316 stainless steel.
- P. Bird screen shall conform to ASTM E437, Type 1, Class 1, 2 x 2 mesh (0.031 inch diameter stainless steel wires). Frame shall be removable Type 316 stainless steel construction.
- Q. All ductwork shall conform accurately to the dimensions shown, the ducts shall be straight and smooth inside with joints neatly finished; ductwork shall be installed so as to preclude the possibility of vibration under all operating conditions.
- R. Tape and seal all joints as per SMACNA Standards.
- S. Elbows shall have a minimum centerline radius of 1-1/2 times the width of the duct. Turning vanes shall be provided at all square elbows. Turning vanes shall be double wall and shall be quiet and free from vibration when the system is in operation.
- T. Provide flexible connections at inlet and discharge of air handling equipment.
- U. Provide volume dampers where indicated on the Contract Drawings and as required to facilitate accurate volume control. The duct of the damper shall be reinforced to prevent vibration. Volume dampers specified with air devices shall be installed in addition to those shown on the Contract Drawings.
- V. Fire dampers shall be provided and installed where indicated on the Drawings and where required by UL and authorities having jurisdiction, and shall be approved by local building codes and in accordance with the requirements of the NFPA.
- W. Provide access doors for all dampers for inspection and maintenance.
- X. Install all ductwork and accessories to provide a system free from buckling, warping, breathing or vibration.

## SECTION 15810 – DUCTWORK AND DUCT ACCESSORIES

---

- Y. All expansion joints in ducts at building expansion joints shall be suitably supported at each end by support guides within 12 inches of joint.
- Z. All ducts at flexible connections with air handling equipment, and fans shall be supported at free end within 12 inches of flexible connection.
- AA. Provisions shall be made for supporting all ductwork, dampers, and other ductwork accessories, where necessary.
- BB. Coordinate all air outlets for compatibility with ceiling system.
- CC. All ductwork shall arrive on site fully fabricated, not in two halves for field fabricated.

### 3.02 ADJUSTMENT

- A. Set volume control devices for approximate positions in preparation for final testing and balancing.
- B. Install fusible links in fire dampers and verify that dampers are in open position.
- C. Start fan system and check for excessive leaks and vibration and correct.

### 3.03 BALANCING

- A. Systems shall be completely tested, adjusted and balanced by a qualified engineer. A complete balancing procedure shall be submitted for approval. All equipment and connections required to balance the systems shall be provided.
- B. All duct systems shall be balanced as specified in Section 15951 - Testing, Adjusting and Balancing.

### 3.04 CLEANING

- A. Remove all loose materials and obstructions from interior of ducts.
- B. Remove debris and waste materials resulting from installation.

### 3.05 PAINTING

- A. Surface Preparation and Shop Painting:
  - 1. Clean and prime coat ferrous metal surfaces of equipment in the factory/shop in accordance with the requirements of Section 09900 - Painting.
  - 2. Coat polished and non-ferrous metal surfaces with corrosion prevention compound which shall be maintained during storage and until equipment begins operations.
- B. Field Painting: Painting required for exterior surfaces of ductwork and insulation, and finish painting of items only primed at the factory, are specified in Section 09900 - Painting.

**SECTION 15810 – DUCTWORK AND DUCT ACCESSORIES**

---

3.06 CONSTRUCTION AND MATERIAL SCHEDULE

A. Schedule of Metal Duct Construction Standards:

Schedule of Duct Construction Standards		
Service	Pressure Classification	Construction Standards
All ductwork on fan discharge side	3" W.G. POS.	SMACNA HVAC Duct Construction Standards
All ductwork on suction side	3" W.G. NEG.	SMACNA HVAC Duct Construction Standards
Transfer air duct not connected to fan	2" W.G. POS. or NEG.	SMACNA HVAC Duct Construction Standards

1. Notes: All accessories, including but not limited to, turning vanes, air turning devices, manual volume dampers, motor operated control dampers, fire dampers, access doors, supports, angles, clamps, hangers and hardware, shall be suitable for the pressure classification given above.
  - a. Non-metallic ductwork shall be constructed as specified in Section 13862 - Non-Metallic Ductwork.

B. Ductwork Material Schedule:

1. As shown on the Contract Drawings.

END OF SECTION

**SECTION 15810 – DUCTWORK AND DUCT ACCESSORIES**

---

NO TEXT ON THIS PAGE

**SECTION 15815**

**Duct Insulation**

**PART 1 GENERAL**

**1.01 SECTION INCLUDES**

A. The Contractor shall provide all labor, materials, and incidentals as specified and required to furnish and install all duct insulation complete with auxiliary equipment and accessories for a proper operation.

B. Index:

<u>Article</u>	<u>Title</u>	<u>Page</u>
		15815-
PART 1	GENERAL.....	1
1.01	Section Includes.....	1
1.02	Related Sections.....	1
1.03	Payment.....	1
1.04	References.....	2
1.05	Submittals.....	3
1.06	Quality Assurance.....	3
1.07	Job Conditions.....	4
PART 2	PRODUCTS.....	4
2.01	Materials.....	4
PART 3	EXECUTION.....	6
3.01	Inspection.....	6
3.02	Preparation.....	6
3.03	Installation.....	6
3.04	Cleaning.....	7
3.05	Schedules.....	7

**1.02 RELATED SECTIONS**

A. Section09900 - Painting

B. Section15076 - Piping and Equipment Identification

**1.03 PAYMENT**

A. There will be no separate payment for the work of this Section; all costs shall be included in the Lump Sum price bid for the Contract.

**1.04 REFERENCES**

A. Reference Standards: Comply with applicable provisions and recommendations of the following, except as otherwise shown or specified.

## SECTION 15815 – DUCT INSULATION

---

General Requirements of this Contract shall supersede the Standards in case of conflict:

- 1.
  2. National Fire Protection Association (NFPA):
    - a. 90A - Installation of Air Conditioning and Ventilating Systems
  3. ASTM International:
    - a. C195 - Mineral Fiber Thermal Insulating Cement
    - b. C449 - Mineral Fiber Hydraulic-Setting Thermal Insulating and Finishing Cement
    - c. C534 - Preformed Flexible Elastomeric Cellular Thermal Insulation in Sheet and Tubular Form
    - d. C916 - Adhesives for Duct Thermal Insulation
    - e. C920 - Elastomeric Joint Sealants
    - f. Small Scale Closed-Cup Apparatus
    - g. E84 - Surface Burning Characteristics of Building Materials
- B. Field Measurements: Take field measurements where required prior to installation, to ensure a proper design.
- C. Where reference is made to one of the above standards, the revision in effect at the time of bid opening shall apply.
- 1.05 SUBMITTALS
- A. Contractor shall submit Shop Drawings and material specifications for the approval of the Engineer. Submittals shall include, but not be limited, to:
1. Samples: Submit for approval samples of the following:
    - a. Thermal Insulation - Flexible.
    - b. Thermal Insulation - Rigid.
    - c. Acoustical Insulation.
  2. Shop Drawings: Submit for approval manufacturer's catalog literature, specifications and illustrations with the following information:
    - a. Thermal properties
    - b. Physical properties
    - c. Fire hazard ratings

## SECTION 15815 – DUCT INSULATION

---

- d. Facing information
- e. Installation instructions
- f. Jointing recommendations for butt joints and longitudinal seams

### 1.06 QUALITY ASSURANCE

#### A. Manufacturer Qualifications:

- 1. Engage a single firm, with undivided responsibility for performance requirements and components of the duct insulation installation.
- 2. Engage a firm which can show successful experience in the manufacture of duct insulation systems of scope and type similar to the required Work.

#### B. Contractor's Qualifications:

- 1. Contractor shall have at least 5 years' experience in the installation of the Work specified. He shall employ only tradesmen with specific skills and experience in this type of Work.
- 2. Contractor shall have undivided responsibility as a single firm for performance and other requirements for the installation of the Work specified herein.

#### C. Requirements of Regulatory Agencies: Comply with applicable provisions of regulatory agencies below and others having jurisdiction.

- 1. Underwriters Laboratories, Incorporated (UL).
- 2. National Fire Protection Association (NFPA).
- 3. Local and State Building Codes and Ordinances.
  - a. New York City Building Code
  - b. New York State Uniform Fire Prevention and Building Code
  - c. New York State Energy Conservation Construction Code

#### D. General: Insulation systems including covering, mastics, adhesives, sealers and facings shall have the following Fire Hazard Classifications in accordance with ASTM E84:

- 1. Flame spread, 25 maximum.
- 2. Fuel contributed, 50 maximum.
- 3. Smoke developed, 50 maximum.

#### E. Source Quality Control: Perform the following tests and inspections at factory.

- 1. Flame Spread
- 2. Smoke Developed

## SECTION 15815 – DUCT INSULATION

---

3. Fuel Contributed
- F. Manufacturer's Markings:
1. Stamp or label with manufacturer's name and brand every package or standard container of covering, adhesive and coating delivered to the job site for use.
  2. Exposed side of insulation shall be legibly labeled by the manufacturer to show thickness, type and manufacturer.

### 1.07 JOB CONDITIONS

- A. Sequencing: Obtain the Engineer's approval of insulation, adhesives, coatings and method of installation before installing any insulation.
- B. All duct leaks shall be sealed prior to installation of external insulation to prevent billowing and damage to insulation.

## PART 2 PRODUCTS

### 2.01 MATERIALS

- A. Manufacturer: Provide insulation from one of the following:
  1. Owens Corning, Toledo, OH.
  2. CertainTeed Corporation, Valley Forge, PA.
  3. Schuller International, Inc. (Johns-Manville), Littleton, CO.
  4. Or approved equal.
- B. Exposed Ductwork Insulation (Rigid): All exposed ductwork as listed under Paragraph 3.05 - Schedules, shall be insulated with minimum 1-1/2" thick (except 2 inches thick for ducts located outdoor and outside air intake plenums) glass fiber board having a density of not less than 3.0 lbs./cu.ft., and a thermal conductivity of not more than 0.23 BTU-inch/hour square feet °F at 75°F mean temperature. The insulation shall be:
  1. No. 814 –Spin-Glas, as manufactured by Johns-Manville, Littleton, CO.
  2. Industrial Board, as manufactured by CertainTeed Corporation, Valley Forge, PA
  3. Or approved equal.
- C. The insulation shall be impaled over pins welded to the duct surface on 12" centers. The pins shall be coated with vapor barrier adhesive, and the insulation shall then be secured with caps over the pins. All joints and breaks in the vapor barrier shall be sealed with 3" wide strips of the vapor barrier facing. All insulation shall be reinforced with corner bead. The facing shall be finished with a 3-ply application of lagging adhesive, glass fabric reinforcing and a finish coat of mastic.



## SECTION 15815 – DUCT INSULATION

---

- D. Concealed Ductwork Insulation (Flexible): All concealed ductwork as listed under Article 3.05 - Schedules, shall be insulated with 1-1/2" thick flexible fiberglass duct insulation, having a thermal conductivity of not more than 0.28 BTU-inch/hour square feet °F at 75°F mean temperature. The insulation shall have a reinforced foil vapor barrier facing. Insulation shall be secured with 4" wide bands of adhesive on 12" centers. All joints shall be sealed by adhering a 2" sealing lap or 3" strips of vapor barrier facing applied with vapor barrier adhesive. On horizontal ducts over 24" wide, welded pins and clips shall be used on the underside on 18" centers.
- E. Internal Duct Liner Insulation - Acoustical Insulation:
1. Type: Fiberglass duct liner board with black surface.
  2. Density: Minimum 1-1/2 lbs. per cubic foot.
  3. Thickness: 1-1/2 inch minimum.
  4. Thermal Conductivity: 0.23 Btu-Inch/hr. ft<sup>2</sup>. °F @ 75°F mean temperature.
- F. Adhesives and Accessories:
1. Acoustical Lining Insulation Adhesive: Insulation shall be applied in cut-to-size pieces attached to the interior of the duct with a nonflammable, fire-resistant adhesive conforming to ASTM C916, Type I. Exposed edges of the liner at the duct ends and at other joints where the lining will be subject to erosion shall be coated with a heavy brush coat of the nonflammable, fire-resistant adhesive to prevent delamination of glass fibers.
  2. Mineral Fiber Insulation Cement: Cement shall be in accordance with ASTM C195.
  3. Lagging Adhesive: Lagging adhesives shall be nonflammable and fire-resistant and shall have flame spread and smoke developed ratings of 25/50 when measured in accordance with ASTM E84.
  4. Contact Adhesive: Adhesive may be dispersed in a non-halogenated organic solvent with a low flash point (flash pint less than minus 25°F when tested in accordance with ASM D3278) or, dispersed in a nonflammable organic solvent which shall not have a fire point below 200°F. The adhesive shall be nonflammable and fire resistant.
  5. Caulking: Caulking shall be in accordance with ASTM C920.
  6. Corner Angles: Nominal 0.016 inch type 316 stainless steel 1 x 1 inch with factory applied kraft backing and adhesive.
  7. Finishing Cement: Mineral fiber hydraulic-setting thermal insulating cement ASTM C449.

## SECTION 15815 – DUCT INSULATION

---

8. Fibrous Glass Cloth and Glass Tape: Fibrous glass cloth and glass tape shall have flame spread and smoke developed ratings of no greater than 25/50 when measured in accordance with ASTM E84.
9. Staples shall be outward clinching Type 316 stainless steel.
10. White Vapor Retarder ASJ (All Service Jacket): For use on hot/cold pipes, ducts, or equipment. Vapor retarder jackets used on insulation exposed in finished areas shall have white finish suitable for painting.
11. Weatherproof Jackets: Type 316 stainless steel jackets shall be smooth sheet, 0.016 inch nominal thickness. Corrugated metal jacket shall not be used outdoors for insulated ducts.

### PART 3 EXECUTION

#### 3.01 INSPECTION

- A. Ensure that all surfaces are clean and dry before applying insulation.

#### 3.02 PREPARATION

- A. Ensure that ductwork has been inspected and released for application of insulation.

#### 3.03 INSTALLATION

- A. Install insulation so as to make surfaces smooth, even and substantially flush with adjacent duct insulation.
- B. Follow manufacturer's application instructions for all materials used.
- C. Duct sizes indicated on Drawings are clear inside dimensions. Increase duct sizes to give designated inside dimensions when internal insulation is used.
- D. Thickness of rigid insulation shall be greater than the seams or angles of ductwork to which it is applied.
- E. Duct insulation shall be continuous through sleeves and prepared openings.
- F. Insulation shall terminate at fire dampers and flexible connections.
- G. Vapor barrier materials shall be applied to form a complete unbroken vapor seal over insulation.
- H. Provide Type 316 stainless steel jacketing and waterproof sealants for insulated ducts exposed to outdoor.
- I. Field Painting shall comply with the requirements of Section 09900 - Painting.
- J. Identification markers and labels shall be in conformance with the Contract Documents and Section 15076 - Piping and Equipment Identification.

## SECTION 15815 – DUCT INSULATION

---

### 3.04 CLEANING

- A. Remove all debris, waste materials and loose foreign matter resulting from installation.

### 3.05 SCHEDULES

- A. Thermal Insulation - Rigid: The following exposed ductwork exposed in room shall be insulated:
  - 1. All outside air intake ducts and plenums from the outside air intake louver, outside air intake shaft, or roof mounted intake up to the point where the duct or plenum is connected to the heating and ventilating units, air conditioning units, or supply fans in heated and air conditioned spaces.
  - 2. All exhaust and return air ductwork from air conditioned spaces.
  - 3. All supply and return air ductwork associated with Air Conditioning Units.
  - 4. All heated and air conditioned ductwork located in unheated spaces.
  - 5. All heated and air conditioned ductwork located outdoor shall be insulated and covered with weatherproof stainless steel jacket.
  - 6. Where indicated on the Contract Drawings.
- B. Thermal Insulation - Flexible: The following ductwork located above hung ceiling shall be insulated:
  - 1. All supply, exhaust and return ductwork associated with air conditioning units.
  - 2. All outside air intake ducts and plenums from the outside air intake louver, outside air intake shaft or roof mounted intake up to the point where the duct or plenum is connected to the heating and ventilating units and supply fans.
  - 3. Where indicated on the Contract Drawings.
- C. Acoustical Insulation: Ductwork shall be internally insulated as specified in the Contract Documents and where indicated on the Contract Drawings.
- D. Insulation Thickness: All ductwork insulation shall be 1-1/2 inch thick except for outside air intake plenum and outside air ductwork insulation which shall be 2 inches thick.

END OF SECTION

**SECTION 15815 – DUCT INSULATION**

---

NO TEXT ON THIS PAGE

**SECTION 15830  
Fans**

**PART 1 GENERAL**

**1.01 SECTION INCLUDES**

- A. The Contractor shall provide all labor, materials, equipment and incidentals to furnish and install all fans in accordance with the requirements specified herein, as shown on the Contract Drawings, or specified in the Contract Documents.
- B. The equipment shall be furnished complete with all accessories, special tools, spare parts, base attachments, mountings, anchor bolts and other appurtenances as specified or as may be required for a satisfactory installation.
- C. All fans shall be furnished in accordance with the schedule shown on the Contract Drawings.
- D. Index:

<u>Article</u>	<u>Title</u>	<u>Page</u>
		15830-
PART 1	GENERAL .....	1
1.01	Section Includes .....	1
1.02	Related Sections .....	2
1.03	Payment .....	2
1.04	References .....	2
1.05	Submittals .....	2
1.06	Quality Assurance And Qualifications .....	3
1.07	Spare Parts And Supplies .....	4
PART 2	PRODUCTS .....	4
2.01	Fans - Condition Of Service And Design Data .....	4
2.02	In-Line Cabinet Fans .....	6
2.03	Centrifugal Base Mounted Fans .....	7
2.04	In-Line Square Centrifugal Fans .....	7
2.05	Up-Blast Roof Mounted Centrifugal Fans .....	8
2.06	Roof Mounted Axial Type Supply Fans .....	9
2.07	Roof Mounted Axial Type Exhaust Fan .....	9
2.08	In-Line Centrifugal Stainless Steel Fans .....	10
2.09	Roof Mounted Centrifugal Exhaust Fans .....	11
2.10	Tube Axial Upblast Roof Exhaust Fan .....	11
2.11	Tubular Centrifugal Inline Duct Fans .....	12
2.12	Wall Mounted Propeller Fans .....	13
2.13	Fiberglass Axial Roof Fans .....	14
2.14	Fiberglass Inline Axial Flow Duct Fans .....	16

## SECTION 15830 - FANS

---

PART 3	EXECUTION.....	17
3.01	Installation.....	17
3.02	Identification.....	18
3.03	Testing.....	18
3.04	Manufacturer's Representative .....	18
1.02	RELATED SECTIONS	
A.	Section 09900 - Painting	
B.	Section 15071 - Vibration Control	
C.	Section 15951 - Testing, Adjusting and Balancing	
D.	Section 16221 - Electric Motors	
1.03	PAYMENT	
A.	No separate payment will be made for performing any work of this Section and all costs thereof shall be included in the lump sum price bid for the Contract, except as provided for in the Specifications.	
1.04	REFERENCES	
A.	Equipment shall comply with applicable provisions and recommendations of the following, except as otherwise shown or specified. American Society of Mechanical Engineers (ASME) American Society of Testing Materials (ASTM) Air Movement and Control Association (AMCA) National Electric Code (NEC) The National Fire Code (NFC) Applicable Federal, State and local laws and/or ordinances	
B.	Where conflict arises between the local codes and the requirements of the National Electrical Code, The National Fire Code, NEMA, ASTM, etc., the more stringent requirements shall prevail.	
1.05	SUBMITTALS	
A.	The Contractor shall submit Shop Drawings for the approval of the Engineer. Submittals shall include, but not be limited, to the following: Preliminary Operation and Maintenance Manuals Final Operation and Maintenance Manuals Spare Parts List Special Tools List	

Reports of Certified Shop Tests

AMCA Approval for Fan Ratings

Shop drawings shall include but not be limited to:

- a. Equipment specifications and data sheets identifying all materials used and methods of fabrication.
- b. Complete assembly, layout, installation and foundation drawings with clearly marked dimensions.
- c. Fan performance curve indicating the operating point.
- d. Details of corrosion resistance coating.
- e. Motor nameplate data as specified in Section 16221 - Electric Motors.
- f. f. Contract Documents and data sheets for all accessories such as roof curbs, dampers, damper operators disconnect switches, vibration isolators etc.
- g. Example equipment nameplate data sheet.
- h. Interconnecting wiring diagrams.
- i. List of recommended lubricants.

B. Operations and Maintenance Manuals

The Contractor shall submit operation and maintenance manuals in accordance with the procedures and requirements of this Contract. Two copies of a preliminary O&M manual shall be included in the Shop Drawing submittal. Without inclusion of these manuals, the submittal will be considered incomplete and will be returned without review.

- C. Lubricants: The manufacturer shall submit a list with a minimum of four (4) manufacturers' standard lubricants which may be used interchangeably for each type of lubricant required. The Contractor shall utilize this list in preparing his comprehensive lubrication survey.

1.06 QUALITY ASSURANCE AND QUALIFICATIONS

- A. The equipment covered by these specifications is intended to be standard equipment of proven performance as manufactured by reputable concerns. Equipment shall be designed, constructed and installed in accordance with the best practices of the trade, and shall operate satisfactorily when installed as shown on the Contract Drawings.
- B. It is the intent of these specifications that all components of the fans be provided by the Contractor through one vendor. The Contractor through the vendor shall

## SECTION 15830 - FANS

---

have the sole responsibility of matching all components and providing equipment which functions together as a system.

### 1.07 SPARE PARTS AND SUPPLIES

- A. Furnish all special tools necessary to disassemble, service, repair and adjust the equipment.
- B. The following spare parts shall be furnished for up to every four (4) same size of fan:
  - One (1) blower with wheel
  - One (1) set bearing and seal
  - One (1) set sheave
  - One (1) shaft
  - Two (2) sets of belts for each belt driven fan
- C. Furnish all additional spare parts as recommended by the equipment manufacturers.
- D. Spare parts lists, included with the Shop Drawing submittal shall indicate specific sizes, quantities, and part numbers of the items to be furnished. Terms such as "1 lot of packing material" are not acceptable.
- E. Parts shall be completely identified with a numerical system to facilitate parts inventory control and stocking. Each part shall be properly identified by a separate number. Those parts which are identical for more than one size, shall have the same parts number.

## PART 2 PRODUCTS

### 2.01 FANS - CONDITION OF SERVICE AND DESIGN DATA

- A. Fans shall be as specified below and shown on the Contract Drawings. The Contractor shall include, as part of this work, all supports required. The fans shall be installed where indicated on the Contract Drawings.
- B. Performance data for all fans shall be based on tests conducted in accordance with the "Standard Test Code for Centrifugal and Axial Fans" as adopted by the Air Movement and Control Association (AMCA) and shall be licensed to bear the AMCA certified rating seal for both sound and air performance. All fans shall be selected from performance curves and not from rating tables. A copy of the curve, indicating the operating point, shall be submitted for each proposed fan.
- C. Unless otherwise indicated, motors shall be of the totally enclosed premium efficiency type. Motors shall not be selected for operation in the service factor



## SECTION 15830 - FANS

---

- range/zone. The maximum brake horsepower required at any point on the performance curve shall not exceed the rated horsepower of the motor.
- D. Motors 1/3 HP and less shall be suitable for use with 115V, single phase, 60 Hz electric service. Motors 1/2 HP or larger shall be for use with 460V, three phase, 60 Hz electric service, unless otherwise indicated. Two speed motors shall be two winding type. Motors shall comply with the requirements of Section 16221 - Electric Motors.
  - E. All fans and damper operators shall each be provided with individual externally mounted disconnect switches. All enclosures shall be NEMA 4X-stainless steel unless otherwise specified.
  - F. All dampers for roof mounted fans shall be mounted in the mounting pedestal with removable access panel for inspection and servicing of damper and operator. Mounting pedestal shall provide solid ventilator support and a weather tight seal.
  - G. All fans shall be statically and dynamically balanced at the speed at which the unit is scheduled to operate. Fans with corrosion resistant coatings shall be balanced after being coated.
  - H. The fans shall be either direct connected or V-belt drive as indicated on the schedule. For motors less than or equal to 10 HP, the V-belt drive shall be selected for 120 percent of rated capacity. For motors larger than 10 HP, the V-belt drive shall be selected for 150 percent of rated capacity. All V-belt drives shall be provided with adjustable sheaves. Exposed V-belt drives shall have removable belt guards with openings to allow for tachometer readings at both drive and fan shafts. Guards shall be so constructed as to allow visual inspection of the belts without removing the guard.
  - I. Vibration isolators shall be provided in conformance with Section 15071 - Vibration Control. Isolators shall have a minimum efficiency of 90 percent. Installation, type, number, and size of isolators shall be in conformance with the manufacturer's recommendations for the frequencies involved.
  - J. Where indicated on the schedule, explosion proof motors, and AMCA Type A spark resistant construction shall be provided. Fans handling explosive gases shall have all parts in contact with gas fabricated of non-ferrous materials; bearings shall not be located in the gas stream. Explosion proof fans shall be provided with NEMA 7 explosion proof disconnect switches, explosion proof damper operators, and explosion proof motors.
  - K. All fan bearings shall be selected for a minimum L-50 life of 100,000 hours at maximum operating speed.
  - L. All fans shall be provided (inside and outside) with baked on Heresite corrosion resistant coating including all accessories but not limited to the housing, wheels, curbs, liners, dampers, damper access sections.

## SECTION 15830 - FANS

---

- M. All fan motors shall be provided with high premium energy efficient totally enclosed fan cooled type. Where indicated on the schedule, explosion proof motors and AMCA Type "A" spark resistant construction fans shall be provided.
- N. All shafts shall be sized so the first critical speed is at least 20 percent over the maximum operating speed. Close tolerance shall be maintained along the length of the shaft.
- O. Each fan shall bear a permanently affixed manufacturer's nameplate containing the model number and individual serial number for future identification.
- P. Fan manufacturer shall provide sound power ratings in the eight octave bands. Sound power levels shall be based on AMCA Standard 301. Sound power ratings shall be in decibels, referenced to  $10^{-12}$  watts.
- Q. All fans shall be secured or anchored to withstand seismic forces anticipated in seismic zone 2A. Equipment shall be provided with seismic restraints in accordance with the latest edition of the Seismic Restraint Manual, Guidelines for Mechanical Systems, as published by the Sheet Metal and Air Conditioning Contractor's National Association, Inc., and in accordance with the latest edition of the City of New York Building Code and referenced Uniform Building Code requirements.

### 2.02 IN-LINE CABINET FANS

- A. Ceiling mounted exhaust fans shall be of the centrifugal direct or belt drive type. The fan housing shall be constructed of heavy gauge galvanized steel. The housing interior shall be lined with 1/2" acoustical insulation. The outlet duct collar shall include an aluminum backdraft damper and shall be adaptable for horizontal or vertical discharge.
- B. The access for wiring shall be external. The motor disconnect shall be externally mounted. The motor shall be mounted on vibration isolators. The fan wheel(s) shall be of the forward curved centrifugal type, constructed of galvanized steel and dynamically balanced.
- C. Ceiling fans shall be Model SP as manufactured by:
  - 1. Greenheck, Schofield, WI.
  - 2. Or approved equal.
- D. Direct drive fans shall be provided with solid state speed control as required.

### 2.03 CENTRIFUGAL BASE MOUNTED FANS

- A. Centrifugal base mounted utility fan shall be airfoil bladed single inlet centrifugal fans equal to Type BAF, as manufactured by:
  - 1. Twin City Fan & Blower, Plymouth, MN.
  - 2. Greenheck, Schofield, WI

## SECTION 15830 - FANS

---

3. Or approved equal.

Fans shall be arrangement of No. 9, V-belt driven for floor mounting. Fans shall be of all aluminum construction conforming to AMCA "B" spark resistant construction. Unit shall be electrically grounded in the field by installing contractor. All hardware shall be Type 316 stainless steel.

- B. Wheels to have aluminum back plate, shroud and airfoil blades. Adjustable drive assemblies to have static resistant belts sized with 1.5 service factor on motor horsepower. Provide unit with all aluminum belt guard. Adjustable motor mounting base to be fabricated of 316 stainless steel. Fan bearings to be provided with aluminum lubrication lines extended to a common point on the bearing stand.
- C. Fans shall be provided with access door, companion flange, motor operated dampers, and inlet boxes.
- D. Stainless steel parts to be mill finish.
- E. Fans shall be provided with housed spring type vibration isolation for a minimum of 95 percent isolation efficiency and having spring assemblies with rubber coated springs.
- F. The bearing supports shall be constructed of welded structural steel members to prevent vibration and rigidly support the shaft and bearings, bearings shall be heavy duty, self-aligning pillow block ball bearings, and grease lubricated. Shafts shall be turned, ground, polished and rust protected.

### 2.04 IN-LINE SQUARE CENTRIFUGAL FANS

- A. In-line square fans shall be of centrifugal belt driven in-line type. The fan housing shall be of the square design constructed of heavy gauge all aluminum and shall include square duct mounting collars.
- B. Fan construction shall include two removable access panels located perpendicular to the motor mounting panel. The access panels must be of sufficient size to permit easy access to all interior components.
- C. The fan wheel shall be centrifugal backward inclined, constructed of aluminum and shall include a wheel cone carefully matched to the inlet cone for precise running tolerances. Wheels shall be statically and dynamically balanced.
- D. Motors and drives shall be mounted out of the airstream with combination motor cover and belt guards. Motors shall be readily accessible for maintenance.
- E. Precision ground and polished fan shafts shall be mounted in permanently sealed, lubricated pillow block ball bearings.
- F. Drives shall be sized for a minimum of 150 percent of driven horsepower. Pulleys shall be of the fully machined cast iron type, keyed and securely

## SECTION 15830 - FANS

---

attached to the wheel and motor shafts. Motor pulleys shall be adjustable for system balancing.

G. Fans shall be Model BSQ as manufactured by:

1. Greenheck, Schofield, WI.
2. Or approved equal.

### 2.05 UP-BLAST ROOF MOUNTED CENTRIFUGAL FANS

A. Roof exhaust fans shall be upblast centrifugal belt driven type. The fan wheel shall be centrifugal backward inclined, constructed of aluminum and shall include a wheel cone carefully matched to the inlet cone for precise running tolerances. Wheels shall be statically and dynamically balanced. The fan housing shall be constructed of heavy gauge aluminum with a rigid internal support structure. Windbands shall have a rolled bead for added strength and shall be joined to curb caps with a welded seam.

B. Motors and drives shall be mounted on vibration isolators, out of the airstream. Fresh air for motor cooling shall be drawn into the motor compartment from an area free of discharge contaminants. Motors shall be readily accessible for maintenance. Drive frame assemblies shall be constructed of heavy gauge steel and mounted on vibration isolators.

C. Precision ground and polished fan shafts shall be mounted in permanently sealed, lubricated pillow block ball bearings. Drives shall be sized for a minimum of 150 percent of driven horsepower. Pulleys shall be of the fully machined cast iron type, keyed and securely attached to the wheel and motor shafts.

D. Motor pulleys shall be adjustable for final system balancing. A disconnect switch shall be externally mounted within NEMA 4X stainless enclosures. A conduit chase shall be provided through the curb cap to the motor compartment for ease of electrical wiring.

E. Fans shall be provided with 12" high insulated prefabricated heavy gauge aluminum roof curb with liner and nailer, dampers and damper access section.

F. Fans shall be Model CUBE as manufactured by:

1. Greenheck, Schofield, WI.
2. Or approved equal.

### 2.06 ROOF MOUNTED AXIAL TYPE SUPPLY FANS

A. Roof mounted supply fan shall be belt driven and axial type hooded propeller roof fans.

## SECTION 15830 - FANS

---

- B. Propellers shall be constructed with cast aluminum blades and hubs. Propellers shall be securely attached to fan shafts. All propellers shall be statically and dynamically balanced.
  - C. Fan hood and base construction shall be aluminum. Hood panels shall be arched with interlocking ribs. Fan bases shall be tall bases. Access doors shall be provided for inspection and service of damper and actuator. Hood support angles shall be heavy gauge galvanized steel. Birdscreens of 1/2" Type 316 stainless steel mesh shall be horizontally mounted in the perimeter of the hood.
  - D. Drive frame and panel assemblies shall be galvanized steel. Drive frames shall be formed channels and fan panels shall have a deep formed inlet venturi.
  - E. Ground and polished steel fan shafts shall be mounted in permanently lubricated, sealed ball bearing pillow blocks. Drives shall be sized for a minimum of 150 percent of driven horsepower. Pulleys shall be fully machined cast iron, keyed and securely attached to propeller and motor shafts. Motor sheaves shall be adjustable for system balancing.
  - F. Fans shall be provided with 12" high insulated prefabricated heavy gauge aluminum roof curb with liner and nailer, dampers and damper access section.
  - G. Fans shall be Model RBCF as manufactured by:
    - 1. Greenheck, Schofield, WI.
    - 2. Or approved equal.
- 2.07 ROOF MOUNTED AXIAL TYPE EXHAUST FAN
- A. Roof mounted exhaust fans shall be as manufactured by:
    - 1. Barry Blower Type AxiFlo, Vaneaxial Upblast, Dayton, OH, of the arrangement indicated.
    - 2. Or approved equal.

Unless otherwise directed, fans shall conform to the layout as shown on the drawings. Motor horsepowers and inlet and outlet velocities shall not be exceeded.
  - B. Fans shall be constructed of low carbon steel and painted with corrosion resistant coating. The inspection shall include welding, dimensions, bearings and overall workmanship.
  - C. Wheels shall be die-formed cast aluminum type.
  - D. Shafts shall be AISI C1045 hot rolled steel turned, ground and polished. The shaft's first critical speed shall be at least 140 percent of the fan's maximum operating speed.
  - E. Wheels shall be dynamically balanced, individually to ANSI S2.19, G6.3. Assembled fans shall then be dynamically balanced using a vibration analyzer

## SECTION 15830 - FANS

---

to measure velocity. The final reading shall not exceed 0.1 inches per second at the fan shaft speed. The exact level of vibration will be recorded on the fan as proof of the final dynamic balance.

- F. The accessories shall include, but not be limited to, belt guard, weather cover, quick open access door, drain, companion flanges, inlet screen, discharge screen, shaft seal, discharge cap, curb cap, spark resistant construction and vibration isolators in accordance with the requirements specified herein and as shown on the Contract Drawings.
- G. Housings shall be constructed of heavy gauge steel, structurally reinforced and suitably braced to prevent vibration or pulsation, and shall be arc welded throughout. Lifting lugs shall be welded to the housing to facilitate handling of the fans. Straightening vanes shall be supplied on vaneaxial fans to convert the helical airflow pattern to a smooth straight flow as it leaves the wheel to improve pressure characteristics and eliminate resonant noise.

### 2.08 IN-LINE CENTRIFUGAL STAINLESS STEEL FANS

- A. In-line centrifugal fans shall be similar to Type TSL, as manufactured by:
  1. Twin City Fan & Blower, Plymouth, MN.
  2. Greenheck, Schofield, WI
  3. Or approved equal.

Fans shall be V-belt or direct driven with companion angle rings for inlet and outlet ductwork. The motor shall be mounted on a continuously welded motor base that is perpendicular to the fan housing, supported by four (4) adjustable riser bolt assemblies.

- B. The fan housing shall be minimum gauge 10 commercial quality 316 stainless steel suitable for temperatures up to 200 F. The inner housing shall be totally enclosed to protect the fan bearings and belts. The inner housing shall be supported to the outer housing by means of air straightening guide vanes. The housing and the wheels shall be continuously welded in compliance with ASME standards. All accessories exterior to the air stream shall be epoxy coated, i.e., motor base and belt guard.
- C. The wheels shall be type BAF air foil industrial quality 316 stainless steel blades having non-overloading horsepower characteristics. The wheels shall be mounted to the fan shaft with a split taper bushing.
- D. The shafts shall be ground and polished. Fan bearings shall be grease lubricated with external fittings. The fan bearings shall be heavy-duty, self-aligning ball or roller type depending on the fan size, motor horsepower, and performance, and relubricable for continuous service. The belts shall be oil, heat and static resistant type oversized for continuous duty. Variable pitch drives shall be provided as standard up to and including fans with 10 horsepower motors. Fans

## SECTION 15830 - FANS

---

shall be complete with suspension clips or support legs as required, companion flanges and spring type vibration isolators.

### 2.09 ROOF MOUNTED CENTRIFUGAL EXHAUST FANS

- A. Roof mounted exhaust fans shall be centrifugal belt or direct drive type. The fan wheel shall be centrifugal backward inclined, constructed of aluminum and shall include a wheel cone carefully matched to the inlet cone for precise running tolerances. Wheels shall be statically and dynamically balanced.
- B. The fan housing shall be constructed of heavy gauge aluminum with a rigid internal support structure. The fan shroud shall have a rolled bead for added strength.
- C. Motors shall be heavy duty ball bearing type, carefully matched to the fan load, and furnished with the specified voltage, phase and enclosure. Motors and drives shall be mounted on vibration isolators, out of the airstream. Fresh air for motor cooling shall be drawn into the motor compartment from an area free of discharge contaminants. Motors shall be readily accessible for maintenance.
- D. Drive frame assemblies shall be constructed of heavy gauge steel and mounted on vibration isolators.
- E. Precision ground and polished fan shafts shall be mounted in permanently sealed, lubricated pillow block ball bearings. Drives shall be sized for a minimum of 150 percent of driven horsepower. Pulleys shall be of the fully machined cast iron type, keyed and securely attached to the wheel and motor shafts. Motor pulleys shall be adjustable for final system balancing.
- F. A fan conduit chase shall be provided through the curb cap to the motor compartment for ease of installation.
- G. Each fan shall bear a permanently affixed manufacturer's nameplate containing the model number and individual serial number for future identification.
- H. Fans shall be provided with 12" high insulated prefabricated heavy gauge aluminum roof curb, dampers and damper access section.
- I. Fans shall be Model GB as manufactured by:
  - 1. Greenheck , Schofield, WI.
  - 2. Or approved equal.

### 2.10 TUBE AXIAL UPBLAST ROOF EXHAUST FAN

- A. Roof mounted upblast exhaust fans shall be of the belt drive tube axial type.
- B. Propeller construction shall be cast aluminum airfoil. A standard square key or tapered bushing shall lock the propeller to the shaft. Propellers shall be statically and dynamically balanced.

## SECTION 15830 - FANS

---

- C. Fan housings shall be constructed of welded heavy gauge steel to assure no air leakage.
- D. Bearing supports shall be constructed of structural steel members to prevent vibration and rigidly support the shaft and bearings. All structural steel parts shall be coated with corrosion resistant to provide a lasting finish.
- E. Close tolerances shall be maintained where the shaft makes contact with the bearing. Bearings shall be heavy duty, grease lubricated, selfaligning ball type in pillow block mounts. Extended lubrication lines shall be provided with external grease fittings.
- F. Windbands shall be constructed of heavy gauge steel with reinforced edges.
- G. Curb caps shall be constructed of heavy gauge steel with a prepunched mounting flange and integral venturi inlet.
- H. Fans shall be provided with 12" high insulated prefabricated heavy gauge aluminum roof curb, dampers and damper access section.
- I. Tube axial upblast roof exhausters shall be Model TAUB as manufactured by:
  - 1. Greenheck , Schofield, WI.
  - 2. Or approved equal.

And shall be supplied as shown on the plans and in the fan schedule.

### 2.11 TUBULAR CENTRIFUGAL INLINE DUCT FANS

- A. General: Fan shall be factory assembled and tested unit complete with fan wheel, fan shaft, bearings, drive, motor and accessories as specified below. Capacity shall be as scheduled on the Contract Drawings.
- B. Materials and Construction:

In-line tubular centrifugal exhaust fans of all aluminum construction with straightening vanes, flanged inlet and outlet connections and support brackets for mounting. Wheel shall be air foil design, non-overloading, statically and dynamically balanced and venturi shaped intake rim. Inner tube construction welded to housing with access plate for servicing and isolation of bearings and drive from air stream.

Accessories for fans shall consist of hinged access doors, inlet and outlet flanges, and belt guards.

Fan shall have direct or V-belt drive with an adjustable pitch motor pulleys. Pulleys shall be cast steel sized for a 1.2 service factor.

The entire fan housing, blades, and all accessories shall be coated with minimum 3 coats (5 mil DFT) of:

- 1. Heresite Series VR-500, Manitowoc, WI.



## SECTION 15830 - FANS

---

2. Or approved equal.

Motors shall be ball bearing drive, mounted on an adjustable platform outside the air stream. Motor HP and electrical characteristics shall be as scheduled on the Contract Drawings.

Belt guard shall be totally enclosed. Lubrication may be oil or grease type. Integral overload protection, factory mounted and wired unfused disconnects shall be provided for all single phase motors.

Provide fans as manufactured by:

1. Loren Cook Co., Springfield, Mo.
2. Greenheck, Schofield, WI
3. Or approved equal.

### WALL MOUNTED PROPELLER FANS

- C. Manufacturer: Provide products as manufactured by::

1. Loren Cook Company, Series AWD or AWB, Powder Springs, GA.
2. Greenheck, Schofield, WI
3. Or approved equal.

- D. Type: Wall mounted, propeller fan.

- E. Capacity: As specified in the Equipment Schedule on the Contract Drawings.

- F. Construction: Steel Wall Fan:

Propellers:

- a. Airfoil design.
- b. Cast aluminum alloy or heavy gauge steel material.
- c. Statically and dynamically balanced.
- d. Six blades.
- e. Propellers equipped with malleable iron split-taper bushing for alignment and locking of propeller to the shaft.
  - 1) Bushing held in place by compression and keyed to the shaft to prevent slipping or loosening.
  - 2) Positioned with three standard capscrews for easy assembly and disassembly.

Venturi and Panel:

- f. Heavy gauge steel.
- g. Designed for airfoil propellers.

## SECTION 15830 - FANS

---

Safety Guard:

- h. 1/2 inch by 1/2 inch PVC coated mesh wire screen that meets OSHA standards.
- i. Removable sections to provide for easy access to motor.

Damper: None.

G. Accessories:

All structural steel used for mounting fans shall be corrosion resistant coated. Mounting hardware shall be steel.

The Contractor to provide additional stiffeners, angles and supports as required to mount the fans.

H. Drive:

Direct or belt drive as shown on the Contract Drawings.

OSHA approved guard.

I. Painting:

All external and internal metal surfaces of fans, guards, (except propellers and motors) shall be factory primed and factory painted in accordance with Section 09900 - Painting.

Propellers shall be factory coated with a 4 coat baked phenolic coating system minimum of 2 to 3 mils dry film thickness total, of:

- a. Heresite Series P-413, Manitowoc, WI.
- b. Or approved equal.

### 2.12 FIBERGLASS AXIAL ROOF FANS

A. Product and Manufacturers: Provide fans as manufactured by:

1. Aerovent, Model VTF Roof Ventilator, Minneapolis, MN
2. Greenheck, Schofield, WI
3. Or approved equal.

B. Type: Roof mounted, Belt drive axial fan with stack cap and butterfly gravity damper and curb base.

C. Capacity: As scheduled on the Contract Drawings.

D. Construction:

Housing:

- a. Polyester resin reinforced with cloth and mat with integral flanges.

## SECTION 15830 - FANS

---

- b. The bearing, base and drive enclosure shall be supported by gussets interlocked into and taped to the outer housing. These structural parts shall all be of laminated glass and resin.
- c. All parts in contact with the air stream shall be constructed of solid fiberglass reinforced plastic using fire retardant resin.

### Wheel:

- d. Constructed using a hand lay-up method.
- e. Glass cloth shall be cut to various template sizes to form laminations which are to be fitted into a mold.
- f. Glass shall be impregnated with resin in a step-by-step process.
- g. The fan wheel shall be cured under pressure in the mold forming a monolithic structure.

### Shaft:

- h. Type 316 stainless steel.
- i. Machined and keyed with the end drilled and tapped.
- j. The wheel shall be held tightly against the shaft shoulder by a stainless steel bolt in the end of the shaft.
- k. Stainless steel set screws shall be used to hold the key in place.

### Shaft Seal:

- l. The ends of the bearing and shaft enclosure shall have cover plates sealed into place with an inert silicone rubber sealant.
- m. The propeller end cover plate shall be fitted with viton or butyl shaft seal and stainless steel retainer plate.

### Bearings:

- n. The bearings shall be sealed pillow block type with grease tubes extending to the outside of the fan housing.
- o. The bearings, shaft and drive shall be enclosed to protect them from air stream contaminants.

Motor Base: A steel motor base with slide rail arrangement for belt adjustment shall be bolted between wide gussets integral with flanges of the fan housing.

Exterior housing of fan and all accessories shall be factory painted in accordance with Section 09900 - Painting.

- p. Exterior surfaces of the FRP fan, shall be factory painted with an epoxy enamel finish equal to Tnemec. Primer coat shall be Tnemec 66 Epoxoline. Finish coat shall be Tnemec 71

## SECTION 15830 - FANS

---

Endurashield. Paint shall be factory applied with touch-up painting in the field as required.

- E. Drive: Direct or belt drive as shown on the Contract Drawings.
- F. Prefabricated Roof Curb:
  - Weatherproof (slope base type for fans located on sloped roof) continuous welded aluminum construction.
  - Insulated with 1-1/2 inch minimum rigid board fiberglass.
  - Provide treated wood nailer on top of curb with gasket.
  - Twelve inch curb height measured from finished roof to top of wood nailer on high side of roof slope or flat roof.
  - Curb to Roof Deck Fasteners: Cadmium plated lag screws or cadmium plated bolts.
  - Refer to architectural Drawings for curb flashing details.
  - Curb shall be furnished from the same fan manufacturer.
- G. Accessories: All furnished from the same fan manufacturer.
  - Stainless steel bolts and nuts.
  - Fiberglass curb base.
  - Fiberglass stack cap.
  - OSHA motor/drive cover - weatherproof.
- H. Coatings: Exterior surfaces of the FRP fan, shall be factory painted with an epoxy enamel finish equal to Tnemec. Primer coat shall be Tnemec 66 Epoxoline. Finish coat shall be Tnemec 71 Endurashield. Paint shall be factory applied with touch-up painting in the field as required.

### 2.13 FIBERGLASS INLINE AXIAL FLOW DUCT FANS

- A. Product and Manufacturer: Provide fans as manufactured by one of the following:
  - 1. Aerovent. Minneapolis, MN.
  - 2. Air Plastics, Inc., Avon Lake, OH
  - 3. Greenheck, Schofield, WI
  - 4. Or approved equal.
- B. Type: Direct or belt driven, FRP construction duct fan, as shown on the Contract Drawings.
- C. Capacity: As scheduled on the Contract Drawings.
- D. Construction:

## SECTION 15830 - FANS

---

Solid FRP construction for corrosive air handling service. Metal components to be coated with corrosion proof paint.

Flanged inlet and outlet connections with bolt holes. Provide viton or butyl Gaskets (minimum 1/4 inch thick) at flexible connections to fan inlet and outlet.

Single piece solid fiberglass wheel, minimum six blades.

Wheel statically and dynamically balanced.

Greaseable ball bearings, external grease fittings, L-10 minimum life rating of 40,000 hours at maximum rated rpm.

Type 316 stainless steel shaft with EPDM slinger, viton or butyl rubber seal and fiberglass coverplate.

Type 316 stainless steel hardware.

Motor mounted on fan housing, adjustable mounting. Drive compartment sealed off securely from any leakage of corrosive fumes.

Accessories:

- a. OSHA approved belt guard.
- b. Corrosion resistant coated steel mounting feet, inlet and discharge flanges with bolt holes.

E. Drive: Direct or belt drive.

F. Belt Guard: FRP cover for belt and motor, OSHA approved with tachometer hole.

G. Access Doors:

Conform to housing curvature.

Gasketed (viton or butyl).

H. Mounting Supports: Provide Type 316 stainless steel support brackets and hardware for fan mounting.

### PART 3 EXECUTION

#### 3.01 INSTALLATION

A. The fans shall be installed, connected and placed in proper working order in accordance with the manufacturer's instructions and details, and the Contract Drawings.

#### 3.02 IDENTIFICATION

A. Each unit of equipment shall be identified with the equipment item numbers given on the Contract Drawings or as directed by the Engineer. A corrosion resistant tag or nameplate, securely affixed in a conspicuous place on each unit

## SECTION 15830 - FANS

---

shall give the equipment item number, manufacturer's name or trademark and such other information as the manufacturer may consider necessary, or as specified, for complete identification.

### 3.03 TESTING

- A. All tests shall be performed in accordance with the requirements of the Contract Documents. Motor tests in accordance with Section 16221 - Electrical Motors.
- B. Field tests shall be performed in accordance with Section 15951 - Testing, Adjusting and Balancing.

### 3.04 MANUFACTURER'S REPRESENTATIVE

- A. The Contractor shall provide the services of a qualified manufacturer's technical representative who shall adequately supervise the installation and testing of all equipment furnished under this Contract. The services of the manufacturer's representative shall be provided for a period indicated and as specified in the Contract Documents.
- B. Any additional time required to achieve successful installation and operation shall be at the expense of the Contractor. The manufacturer's representative shall sign in and out at the office of the Resident Engineer each day he is at the project.
- C. Training:  
The Contractor shall provide training for City personnel. The Contractor shall include in his request for manufacturer approval a certification that the manufacturer has been advised of the stringent requirements for training, and that the costs associated with said training submittals and training have been included in the manufacturer's pricing.

END OF SECTION

**GENERAL SPECIFICATION 16010 - GENERAL ELECTRICAL REQUIREMENTS**

**SECTION 16010  
General Electrical Requirements**

**PART 1 GENERAL**

**1.01 SECTION INCLUDES**

- A. General electrical requirements shall be provided in accordance with the requirements specified under this section, the Detailed Specifications and the Contract Drawings.
- B. The Contractor shall provide all labor, materials and equipment required to perform the work as specified in the General and Detailed Specifications and shown on the Contract Drawings. The work shall also include the following:
  - 1. Inserts and other electrical items which shall be installed embedded in concrete, or built into walls, partitions, ceilings or panels constructed by other Prime Contractors.
  - 2. Installation procedures and schedules under other contracts shall be reviewed and coordinated with other Prime Contractors regarding the installation of electrical items that must be installed.
  - 3. Keep informed of the construction so the electrical work shall be installed within such time periods as will not delay the work of the other Prime Contractors.
  - 4. Notify other Prime Contractors in advance of the installation of the work included, so they shall have sufficient time for coordination and installation of interrelated items that are included in their contracts and that must be installed in conjunction with the work included under this Contract.
- C. The following index of this Section is presented hereinafter for convenience:

<u>Article</u>	<u>Title</u>	<u>Page</u>
		16010-
PART 1	GENERAL .....	1
1.01	SECTION INCLUDES .....	1
1.02	PAYMENT .....	2
1.03	RELATED SECTION .....	2
1.04	REFERENCES .....	2
1.05	SUBMITTALS .....	2
1.06	QUALITY ASSURANCE .....	2
PART 2	PRODUCTS.....	4
2.01	POINT-TO-POINT FIELD WIRING DIAGRAMS .....	4
2.02	SHOP FINISHES.....	4
PART 3	EXECUTION.....	5

## GENERAL SPECIFICATION 16010 - GENERAL ELECTRICAL REQUIREMENTS

- |      |                                  |   |
|------|----------------------------------|---|
| 3.01 | MAINTENANCE OF OPERATIONS .....  | 5 |
| 3.02 | DEMONSTRATION OF EQUIPMENT ..... | 5 |
| 3.03 | RESTORATION.....                 | 6 |
- 1.02 PAYMENT
- A. Payment for general electrical requirements shall be made as provided for in the Detailed Specifications.
- 1.03 RELATED SECTION
- A. General Specification 09900 - Painting.
- 1.04 REFERENCES
- A. General electrical requirements shall comply with the latest applicable provisions and recommendations of the following:
1. NYCEC, New York City Electrical Code
  2. NYCCC, New York City Construction Code
  3. NFPA 70, National Electrical Code.
  4. NFPA 70E, Standard for Electrical Safety in the Workplace
  5. NFPA 101, Life Safety Code
  6. NEMA, National Electrical Manufacturers Association.
  7. UL, Underwriters Laboratories Incorporated.
  8. OSHA 1910 Subpart S, Electrical
- 1.05 SUBMITTALS
- A. Contractor shall submit Shop Drawings and material specifications for the approval of the Engineer. Submittals shall include, but not be limited, to:
1. Point-to-point field wiring diagrams.
  2. Qualifications of proposed wiring coordinator who shall prepare the point-to-point field wiring diagrams.
- B. Reports: Demonstration of equipment report shall be submitted.
- 1.06 QUALITY ASSURANCE
- A. General:
1. All equipment and devices, provided under each Contract, shall be properly connected and interconnected with other equipment and devices so as to render the installations complete for successful operation, regardless of whether all the connections and interconnections are specifically mentioned in the Sections or shown on the Contract Drawings.



## **GENERAL SPECIFICATION 16010 - GENERAL ELECTRICAL REQUIREMENTS**

2. Similar products shall be by the same manufacturer for uniformity on the Contract.
3. Electrical material and equipment shall be new and shall bear the label of UL, or other nationally recognized, independent testing laboratory, wherever standards have been established and label service regularly applies.
4. Where execution of the work under this Contract requires certain systems and equipment to be modified, the Contractor shall perform the work with due regard to maintenance of operations and construction staging in accordance with the Detailed Specifications.
5. The modification work shall be coordinated in advance with the plant superintendent and existing conditions. Contractor shall field determine and make such investigations as required to determine the functionality of each circuit and identify circuit terminations as required for the modifications intended to ensure the proper interface of all components for a complete functional system.
6. The Contractor shall retain the services of a wiring coordinator, to prepare the point-to-point field wiring diagrams. The wiring coordinator shall have experience in the development of the diagrams of the type specified and shall have served in a similar role on a project of similar size and complexity.

### **B. Area Classifications:**

1. Materials and equipment for all indoor areas shall conform to the area classifications shown on the Contract Drawings or stated in the Detailed Specifications.
2. Materials and equipment for all outdoor areas shall conform to corrosive requirements, unless shown otherwise on the Contract Drawings or stated in the Detailed Specifications.
3. The locations and requirements shall be in accordance with the following:
  - a. Materials, equipment and incidentals installed in corrosive areas shall meet NEC and NEMA requirements for corrosive locations. Enclosures installed in corrosive locations shall meet NEMA 4X requirements.
  - b. Materials, equipment and incidentals installed in hazardous locations shall meet NEC requirements for the Class and Division designated. Enclosures installed in hazardous locations shall be provided with stainless steel hardware and watertight gasketing.
  - c. Materials, equipment and incidentals installed in dusty locations shall meet NEC and NEMA 12 requirements.

## GENERAL SPECIFICATION 16010 - GENERAL ELECTRICAL REQUIREMENTS

### PART 2 PRODUCTS

#### 2.01 POINT-TO-POINT FIELD WIRING DIAGRAMS

- A. The Contractor shall provide point-to-point field wiring diagrams for all equipment, including equipment provided by other Prime Contractors.
- B. The diagrams shall be developed for performance of the work and to document terminations. The diagrams shall be prepared based upon approved shop drawings of related Contracts and inspections as necessary to complete the diagrams. The diagrams shall include:
  - 1. External wiring for each piece of equipment, panel, instrument and other devices to control stations, lighting panels and motor controllers. The diagrams shall include control, status, signal and power wiring. Power diagrams shall include connections to switchgear, motor control centers, panelboards, panels and field devices.
  - 2. Numbered terminal block identification for each wire termination.
  - 3. Identification of the assigned wire numbers and color coding for all interconnections.
  - 4. Identification of all wiring by the conduit tag in which the wire is installed.
  - 5. Terminal, junction, and pull boxes through which wiring is routed.
  - 6. Identification of equipment with functional name and number to which wiring is to be connected.

#### 2.02 SHOP FINISHES

- A. Electrical equipment shall be shop painted in accordance with the requirements of General Specification 09900 - Painting.
- B. Exposed ferrous metal surfaces except aluminum, bronze, brass and stainless steel components shall be cleaned with a commercial blast and primed with one coat of rust inhibitive primer.
- C. Manufactured assemblies such as switchgear, substations, motor control centers, panelboards and motor controllers shall be shop painted in accordance with the requirements of General Specification 09900 - Painting.
- D. Other equipment shall be painted with the manufacturer's best grade finish paint system compatible with the finish coatings specified in General Specification 09900 - Painting.

## **GENERAL SPECIFICATION 16010 - GENERAL ELECTRICAL REQUIREMENTS**

---

### **PART 3 EXECUTION**

#### **3.01 MAINTENANCE OF OPERATIONS**

- A. Where execution of the work under this Contract requires certain equipment to be taken out of service, the Contractor shall perform the work with due regard to maintenance of operations and construction staging in accordance with the Detailed Specifications.
- B. The Contractor shall schedule the work in advance with the Engineer so as not to affect proper plant operations. When the work is scheduled, the Engineer shall be notified 48 hours prior to proceeding with the work to allow time for the plant superintendent to perform load switching and alternation of equipment.
- C. To the maximum extent possible at the end of the workday, all equipment shall be back in place and ready for its normal service use should a plant emergency arise. In addition, should an emergency condition occur during execution of the work, at the request of the plant engineer, the equipment shall be placed back in service immediately and turned over to plant personnel.
- D. In the event of accidental shutdown of plant equipment the Contractor shall notify plant personnel immediately to allow for an orderly restart of affected equipment.

#### **3.02 DEMONSTRATION OF EQUIPMENT**

- A. The Contractor shall demonstrate, in the presence of the Engineer that all electrical systems and electrically operated equipment operates as specified, designed and as required.
- B. The Contractor shall coordinate the demonstration of the electrical systems which are part of other Contracts with the other Prime Contractors.
- C. The demonstration of equipment shall include the following:
  - 1. All power circuits shall be operated to verify proper connection to equipment. Mechanical key-interlocks for circuit breakers shall be operated to verify their proper operation. Power shall be removed and reapplied to automatic transfer switches to verify their operation.
  - 2. Emergency power systems shall be activated to verify their automatic start-up, proper operation while running and proper deenergization and cool down upon availability of normal power.
  - 3. All pushbuttons, indicating lights and similar devices shall be operated to verify proper connection and function. All devices, such as pressure and flow switches and similar devices shall be operated to verify that shut-downs and control sequences operate as required.
  - 4. The Contractor, with coordination of the other Prime Contractors, shall operate the systems to verify wiring and adjust the controls, as required, to achieve proper operation. This shall include wiring, timing and switching functions.

## GENERAL SPECIFICATION 16010 - GENERAL ELECTRICAL REQUIREMENTS

- D. The Contractor shall provide a demonstration of equipment report. The report shall include complete information on time, schedule, tasks performed, persons contacted, problems corrected, and all other pertinent information.

### 3.03 RESTORATION

- A. The Contractor shall field paint after installation marred or scratched surfaces. All scratches, abrasions and other damage to equipment shall be touch-up painted in accordance with the requirements of General Specification 09900 - Painting.

END OF SECTION

**SECTION 16055  
Shock Hazard and Arc Flash Studies**

PART 1 GENERAL

1.01 SECTION INCLUDES

- A. Requirements for providing Shock Hazard and Arc Flash studies: Studies for determining Shock Hazard Boundaries and Arc Flash Incident Energies, in and around all electrical equipment, and notifying all personnel of boundaries and energies, shall be provided in accordance with the requirements specified under this Section, the Detailed Specifications and the Contract Drawings.
- B. The Shock Hazard and Arc Flash Studies shall include a short circuit study and a protective device coordination study. Approval shall be obtained for the use of information from existing short circuit and protective device coordination studies.
- C. The following index of this Specification is presented for convenience:

<u>ARTICLE</u>	<u>TITLE</u>	<u>PAGE</u>
		16055-
PART 1	GENERAL .....	1
1.01	SECTION INCLUDES .....	1
1.02	PAYMENT .....	2
1.03	RELATED SPECIFICATIONS .....	2
1.04	REFERENCES .....	2
1.05	ARC FLASH STUDY REQUIREMENTS .....	3
1.06	SUBMITTALS .....	4
1.07	QUALITY ASSURANCE .....	6
PART 2	PRODUCTS.....	6
2.01	COMPUTER SOFTWARE .....	6
PART 3	EXECUTION.....	6
3.01	EXAMINATION .....	6
3.02	DATA COLLECTION AND MODELING .....	7
3.03	ARC FLASH STUDY .....	7
3.04	REPORTS .....	8
3.05	LABELS .....	9
3.06	TRAINING AND STANDARD OPERATING PROCEDURES .....	9

1.02 PAYMENT

- A. Payments for Shock Hazard and Arc Flash Studies shall be made as provided for in the Detailed Specifications.

1.03 RELATED SPECIFICATIONS

- A. General Specifications 16010 - General Electrical Requirements
- B. General Specifications 16076 - Labeling and Identification
- C. General Specifications 16292 - Power Distribution System Coordination

1.04 REFERENCES

A. DEFINITIONS

- 1. Electric Utility or Utility - Consolidated Edison Company of New York
- 2. Arc Flash Studies - Shock Hazard and Arc Flash Studies
- 3. AFIE - Arc Flash Incident Energy
- 4. SHB - Shock Hazard Boundary
- 5. PE or Licensed Engineer - Licensed Professional Engineer in the State of New York

B. REFERENCE STANDARDS

The Shock Hazard and Arc Flash Studies shall comply with the latest applicable provisions and recommendations of the following:

- 1. NYC DEP - EH&S requirements
- 2. NYC DEP BWT - Arc Flash Personal Protective Equipment BWT Guidelines.
- 3. NFPA 70E - Standard for Electrical Safety in the Workplace
- 4. IEEE 1584 - IEEE Guide for Performing Arc-Flash Hazard Calculations
- 5. NYCEC - New York City Electrical Code
- 6. ANSI Z535.4 - Product Safety Signs and Labels

7. IEEE C37.04 - IEEE Standard Rating Structure for AC High-Voltage Circuit Breakers Rated on a Symmetrical Current Basis.
8. IEEE C37.010 - IEEE Application Guide for AC High-Voltage Circuit Breakers Rated on a Symmetrical Current Basis.
9. IEEE C37.13 - IEEE Standard for Low-Voltage Power Circuit Breakers used in Enclosures.
10. IEEE 141 - IEEE Recommended Practice for Electric Power Distribution for Industrial Plants
11. IEEE 242 - IEEE Recommended Practice for Protection and Coordination of Industrial and Commercial Power Systems
12. IEEE 399 - IEEE Recommended Practice for Industrial and Commercial Power System Analysis
13. IEEE 1015 - IEEE Recommended Practice for Applying Low-Voltage Breakers Used in Industrial and Commercial Power Systems
14. OSHA 1910 Subpart S - Electrical

1.05 ARC FLASH STUDY REQUIREMENTS

- A. The arc flash study shall be conducted on all electrical equipment. The equipment to be studied shall include all electrical equipment from the Electric Utility Point of Service (POS) to the electrical energy utilization point. This includes but is not limited to:
  1. All sources of energy including the electric utility, alternative energy sources, emergency generators, legally required generators, optional standby generators and motors.
  2. All medium and low-voltage equipment inclusive of equipment of nominal operating voltage less than 240 VAC.
  3. Direct Current equipment and requirements shall be as defined in the Detailed Specifications.

4. All medium and low-voltage electric distribution equipment including but not limited to switchgears, current limiting reactors, motor control centers (MCC), distribution and lighting panelboards, automatic transfer switches (ATS) and control panels.
  5. All feeders and branch circuits.
  6. All protective devices.
- B. The arc flash study shall be conducted for different modes of electric equipment operation and the modes producing the most severe arc flash incident energy and the most restrictive shock hazard boundary shall be selected for the display on the required labels. Modes will be as directed by the Engineer but at a minimum shall be as listed below:
1. Mode 1 – All electric utilization equipment which are normally operated, are in the ON STATE and connected in their normal configurations to the normal sources. In the normal configuration, devices such as tie breakers which are normally in the open state remain in the open state for this mode.
  2. Mode 2 – As Mode 1 but with all electric utilization equipment in the OFF STATE.
  3. Mode 3 – All emergency and standby electric utilization equipment are in the ON STATE and connected to sources activated by the loss of the normal sources.
  4. Mode 4 – As Mode 3 but will all emergency and standby electric utilization equipment in the OFF STATE.

1.06 SUBMITTALS

- A. Contractor shall submit working drawings, shop drawings and material specifications for the approval of the Engineer in accordance with the requirements of the General Conditions, Article 4 - Contractor's Working Drawings, Design and Shop Drawings; and as specified under Division 1 of the Detailed Specifications
1. Qualifications of proposed Licensed Professional Engineers/ Engineering firms that will conduct arc flash studies shall be submitted. Submit firm experience records demonstrating at least five (5) years conducting power system studies inclusive of shock hazard and arc flash studies along with the contact information of five (5) references for installations where arc flash studies have been completed. The contact information shall include name,



phone numbers, email and address of the references. The contacts shall be able to speak about the work done at the reference locations.

2. Name, model, version of the software package that will be used in the Arc Flash Studies. The software package shall demonstrate compliance with IEEE 399, IEEE 1584 and NFPA 70E. The software package shall be capable of producing samples of all equipment labels recommended even if final labels will be produced by a third party vendor.
  3. Calculations and results of the arc flash studies shall be submitted. The arc flash studies shall be submitted in a report format. The report shall contain recommended samples of the labels required for each type of equipment where personnel shall be required to interface with electrical equipment for operation, adjustment, repair or modification. The report shall be stamped and signed by the Licensed Engineer.
  4. Electronic copies shall be submitted in addition to the above report. The format of the electronic submission shall allow the following:
    - a. The review of all submittals by common readers such as Adobe Acrobat portable document format and
    - b. The review of all submittals in the native software application in which the report was prepared.
  5. Work sequence for the application of equipment labels shall be submitted. The sequence shall indicate the schedule of work, time frame and downtime if any for the equipment. The work sequence shall be submitted at least 45 days in advance prior to confirmation of field labeling dates.
- B. Preliminary arc flash studies shall be submitted to the Engineer prior to receiving final approval of the distribution equipment shop drawings and/or prior to release of equipment drawings for manufacturing. If completion of the preliminary study may cause delays in equipment shipments, approval from the Engineer shall be obtained for a preliminary submittal of data to ensure that the selection of device ratings and characteristics will be satisfactory to properly select the distribution equipment. Final formal arc flash studies shall be provided to verify preliminary findings.

- C. A report shall be submitted detailing the equipment labeled and whether it was not possible to accomplish the labeling of specific pieces of equipment and the reasons for this.

1.07 QUALITY ASSURANCE

A. General:

1. Arc Flash Studies shall be completed using approved computer software programs. No manual studies will be accepted.
2. The arc flash studies shall be performed in accordance with the latest applicable provisions and recommendations of the Reference Standards listed in 1.04 B above.
3. The Contractor shall retain the services of a Professional Engineer, licensed in the State of New York, to perform the power system studies inclusive of arc flash studies. The Licensed Engineer shall be from an independent engineering firm, or as directed by the Engineer. The Licensed Engineer shall have at least five (5) years experience in conducting power system studies inclusive of arc flash studies.
4. The Contractor shall coordinate with the Licensed Engineer performing the studies whether or not the Licensed Engineer has been selected by the Contractor, and assist the Licensed Engineer in the collection of all information necessary to complete the studies specified.

PART 2 PRODUCTS

2.01 COMPUTER SOFTWARE

- A. The only software program to conduct the arc flash study shall be as follows:
  1. Design Base 5.0 (or version approved by Engineer) by Power Analytics Corporation

PART 3 EXECUTION

3.01 EXAMINATION

- A. The Contractor shall ensure that all other provisions of the Contract are satisfied inclusive of all vendors of electrical equipment has been approved, all working drawings and as built data relating to all equipment submitted and approved.

- B. The Contractor shall ensure that the results of General Specification 16292 – Power Distribution System Coordination have been submitted and the settings of all protective devices have been approved.
- C. The Contractor shall not commence arc flash study until all prior studies and submittals to be reused in the arc flash study has been submitted and approved. Arc Flash studies based on equipment or equipment data and settings which should have had prior approvals in an earlier stage of the project will be rejected outright.

3.02 DATA COLLECTION AND MODELING

- A. The Contractor shall ensure that the collection of all data required to support studies under General Specification 16292 – Power Distribution System Coordination and Studies under this Section are input into a comprehensive and accurate software model of the electrical distribution system.
- B. Data shall include but not be limited to:
  - 1. Maximum and minimum short circuit infeed data of all sources including current magnitudes, X/R ratios and sequence values.
  - 2. Information on all installed equipment such as cable lengths, cable sizes, and cable impedance per unit length.
  - 3. All data to determine clearing times of protective devices.
- C. An accurate and comprehensive model of the electrical distribution system shall permit the evaluation of the short circuit currents at all nodes in the system. The model shall also permit the coordination of protection devices installed at nodes upstream and downstream of a specific node. All nodes incorporated in the model shall be approved before any analyses are commenced:

3.03 ARC FLASH STUDY

- A. For each piece of equipment a shock hazard analysis complying with the requirements of NFPA70E shall be completed and shall detail the following as minimum:
  - 1. Equipment and subpart if applicable
  - 2. Nominal voltage
  - 3. Restricted approach boundary
  - 4. Limited approach boundary

- B. The Arc Flash analysis shall cover the Modes of operation detailed in Article 1.05 of this Section ensuring that each node is studied for each of maximum and minimum short circuit contribution of the energy sources connected to the system. The following shall be completed:
1. Confirm the results of Section 16292.
  2. Extend the results of subparagraph 3.03 B. 1 of this Section as required to complete arc-flash study
  3. Calculate the arc fault currents
  4. Determine the protective device operating times
  5. Determine the incident energies
  6. Determine the flash protection boundaries
  7. Determine the incident energies at the boundaries determined in the shock hazard analysis and at the working distance.
  8. Determine the Hazard/Risk categories at the boundaries determined in subparagraphs 3.03 B.6 and 3.03 B.7.
  9. Recommend the appropriate required level of PPE for workers within the flash protection boundaries, the shock hazard boundaries and the working distance.

3.04 REPORTS

- A. A report shall be submitted detailing the results of this study, and color copies of labels that will be prepared for each piece of equipment. The report shall contain at the minimum the following information:
1. Executive Summary including Introduction, Scope of Work and Results/Recommendations
  2. All raw data collected and organized by common category
  3. Study One Line Diagrams for each configuration
  4. Impedance Diagrams for each configuration
  5. Complete Fault and Protective Device Coordination Study
  6. Shock Hazard/Arc Flash Analysis results, inclusive of tabular listing showing for each piece of equipment the following minimum information:
    - c. Equipment and Subpart
    - d. Nominal Operating Voltage
    - e. Restricted Approach Boundary

- f. Limited Approach Boundary
- g. Short Circuit Amps
- h. Clearing Time of Fault
- i. Flash Protection Boundary

3.05 LABELS

- A. The Contractor shall affix arc flash labels to each piece of equipment. The labels shall contain the results of this Section. The label content shall be approved by the Engineer before affixing the labels to the equipment. The labels shall indicate location in the facility of a copy of the studies generating the labels. Labels shall be provided in accordance with General Specification 16076 – Labeling and Identification.

3.06 TRAINING AND STANDARD OPERATING PROCEDURES

- A. The Contractor shall conduct training of the owner's qualified electrical personnel on the potential arc flash hazards associated with the working of the energized equipment.

END OF SECTION

NO TEXT ON THIS PAGE

SECTION 16061  
Grounding

PART 1 GENERAL

1.01 SECTION INCLUDES

- A. Requirements for providing grounding. Grounding shall be provided in accordance with the requirements specified under this section, the Detailed Specifications and the Contract Drawings.
- B. The grounding work shall be a complete system for the electrical and instrumentation systems, structures and equipment. The work shall include grounding of all electrical equipment, transformer neutrals, equipment enclosures, grounding electrodes, fences, and gates.
- C. The following index of this Section is included for convenience:

<u>Article</u>	<u>Title</u>	<u>Page</u>
		16061-
PART 1	GENERAL .....	1
1.01	Section Includes .....	1
1.02	Related Sections.....	1
1.03	Payment.....	1
1.04	References.....	2
1.05	Submittals .....	2
1.06	Quality Assurance.....	2
1.07	Delivery, Storage And Handling.....	2
PART 2	PRODUCTS.....	2
2.01	Ground Cable .....	2
2.02	Ground Rods.....	3
2.03	Grounding Connectors .....	3
PART 3	EXECUTION.....	3
3.01	Installation.....	3
3.02	Field Testing .....	4

1.02 PAYMENT

- A. Payment for grounding shall be made as provided for in the Detailed Specifications.

1.03 RELATED SECTIONS

- A. General Specification 16121 – Low-Voltage Wires, Cables and Accessories.

## GENERAL SPECIFICATION 16061 - GROUNDING

---

- B. General Specification 16124 – Medium-Voltage Cables and Accessories.
- C. General Specification 16131 - Electric Conduit System
- D. General Specification 16133 – Underground Ducts – Ducts in Concrete.
- E. General Specification 16134 – Electric Manholes

### 1.04 REFERENCES

#### A. DEFINITIONS

- 1. Grounding
  - a. Grounding and grounding system shall be used interchangeable in this Section and the Specifications to mean, the means and methods by which all electrical and instrumentation systems are grounded for the purposes of attaining safety grounding, equalization of ground potential, reducing ground potential rises during fault events and the grounding of the ungrounded conductor as required by the NYCEC and Electric Utility Standards
- 2. Electric Utility
  - a. All references to the Electric Utility shall mean the Consolidated Edison Company.

#### B. REFERENCE STANDARDS

- 1. Grounding shall comply with the latest applicable provisions and recommendations of the following:
  - a. NYCEC – New York City Electrical Code..
  - b. NFPA 70 - National Electrical Code.
  - c. Electric Utility - Standards and Guidelines.
  - d. UL Standard No. 467 - Electrical Grounding and Bonding Equipment.

### 1.05 SUBMITTALS

- A. Contractor shall submit Shop Drawings and material specifications for the approval of the Engineer. Submittals shall include, but not be limited to:
  - 1. A list of proposed manufacturers with the products they produce proposed for the contract.
  - 2. Manufacturer's catalog cuts for the grounding materials proposed for use.



## GENERAL SPECIFICATION 16061 – GROUNDING

---

3. Scaled Shop Drawings showing proposed routing and layout of the grounding system.
- B. Field test report shall be submitted.
- 1.06 QUALITY ASSURANCE
- A. The grounding system maximum resistance shall not exceed 5 ohms under normally dry conditions. All structures and metal equipment containing electrical apparatus shall be connected to ground.
  - B. All grounding associated with the Con Edison service feeders shall be in accordance with the requirements of Consolidated Edison Company.
- 1.07 DELIVERY, STORAGE AND HANDLING
- A. The grounding equipment shall be delivered, stored and handled in accordance with the Detailed Specifications and the manufacturer's recommendations.
- PART 2 PRODUCTS
- 2.01 GROUND CABLE
- A. The ground cable shall be soft drawn bare stranded copper conforming to ASTM B8 and B189, No. 8 AWG minimum size.
  - B. The insulated cable for equipment grounding shall conform to the requirements of General Specification 16121 - Electric Wires and Cables.
  - C. Ground cable shall be as manufactured by:
    1. Erico
    2. General Cable, KY.
    3. Or approved equal.
- 2.02 GROUND RODS
- A. Ground rods shall be stainless steel, 3/4-inch diameter and 10 feet long.
  - B. Ground rods shall have a drive point at the lower ends. The upper end of each rod shall be equipped with bronze, clamp type connectors with not less than four bolts.
  - C. Ground rods shall be as manufactured by:
    1. Erico of Pentair
    2. Blackburn of Thomas and Betts, MN.
    3. Thompson Lightning Protection Inc, MN
    4. Or approved equal.

2.03 GROUNDING CONNECTORS

- A. Compression connectors shall be heavy duty copper. Bolted connectors shall be copper alloy castings, designed specifically for the items to be connected, and assembled with Durium or silicone bronze bolts, nuts and washers.
- B. Welded connections shall be by exothermic process utilizing molds, cartridges and hardware designed specifically for the connection to be made.
- C. Bolted or compression grounding connectors shall be as manufactured by:
  - 1. Burndy, Manchester, NH.
  - 2. Thomas and Betts, Memphis, TN.
  - 3. Or approved equal.
- D. Welded grounding connections shall be as manufactured by:
  - 1. Cadwell, WA.
  - 2. Or approved equal.

PART 3 EXECUTION

3.01 INSTALLATION

- A. A complete ground grid system shall be installed as shown on the Contract Drawings.
- B. Ground cable shall be installed around perimeter of structures at a minimum of 2 feet-6-inches below grade.
- C. Ground rods shall be installed 2 feet below grade, 2 feet from foundation walls and shall extend 10 feet vertically into the earth.
- D. Test points shall be installed at locations and in accordance with the details shown on the Contract Drawings.
- E. Equipment shall be connected in accordance with the details shown on the Contract Drawings. All steel column and underground connections shall be welded except for test points.
- F. Metal casings or supporting frames of electrical equipment, such as transformers, panel boards, control panels, motor control centers, and individual motor controllers shall be grounded. The equipment shall be thoroughly grounded to the facility grounding system. All metal conduits leaving all electrical equipment shall be grounded. Grounding type fittings shall be installed on flexible conduits.

## GENERAL SPECIFICATION 16061 – GROUNDING

---

- G. An insulated cable for equipment grounding shall be installed with the phase conductors within the conduit for the nominal 120 volt and higher power, lighting and control circuits.

### 3.02 FIELD TESTING

- A. After installation, the completed ground system shall be field tested for operation and conformance. The field tests shall be witnessed by the Engineer and certified by the Contractor. The Contractor shall provide testing consisting of the following:
  - 1. Resistance testing shall be made using a Biddle, Null Balance Earth Tester or Fluke, Earth Ground Testers not less than 48 hours after rainfall. Resistance values above 5 ohms shall be brought to the Engineer's attention.
  - 2. Grounded cables and metal parts shall be continuity tested. The conduit system shall be ground tested in accordance with the requirements of General Specification 16131 - Electric Conduit System.
- B. The Contractor shall provide a Field Test Report, the report shall identify the testing performed and the results obtained.

END OF SECTION

**GENERAL SPECIFICATION 16061 - GROUNDING**

---

NO PAGES IN THIS SECTION

**SECTION 16071  
Supporting Devices**

**PART 1 GENERAL**

**1.01 SECTION INCLUDES**

- A. Requirements for providing supporting devices. Supporting devices shall be provided in accordance with the requirements specified under this Section, the Detailed Specifications and the Contract Drawings.
- B. The supporting devices shall be a complete system for the equipment. The work shall include providing all required support devices to properly mount and secure all equipment furnished under this Contract.
- C. This section also includes equipment anchorage and restraints suitable to meet the specified seismic requirements.
- D. The following index of this Section is included for convenience:

<u>Article</u>	<u>Title</u>	<u>Page</u>
		16071-
PART 1	GENERAL .....	1
1.01	SECTION INCLUDES .....	1
1.02	PAYMENT .....	1
1.03	RELATED SECTIONS .....	2
1.04	REFERENCES .....	2
1.05	SUBMITTALS .....	2
1.06	QUALITY ASSURANCE .....	2
1.07	DELIVERY, STORAGE AND HANDLING .....	3
PART 2	PRODUCTS.....	3
2.01	MANUFACTURERS .....	3
2.02	CHANNELS, FITTINGS AND BRACKETS.....	3
2.03	CONDUIT HANGERS, SUPPORTS AND INSERTS .....	4
PART 3	EXECUTION.....	4
3.01	INSTALLATION .....	4

**1.02 PAYMENT**

- A. Unless otherwise specified in the Detailed Specifications, no separate payment will be made for performing any work required under this Section and the Contractor shall include all costs thereof in its lump sum price bid for the Contract.

## GENERAL SPECIFICATION 16071 – SUPPORTING DEVICES

---

### 1.03 RELATED SECTIONS

- A. General Specification 16131 - Electric Conduit System

### 1.04 REFERENCES

- A. Supporting devices shall comply with the latest applicable provisions and recommendations of the following:
  1. ASTM A1011/A1011M - Standard Specification for Steel, Sheet and Strip, Hot-Rolled, Carbon, Structural, High-Strength, Low-Alloy, High-Strength, Low-Alloy with Improved Formability, and Ultra-High Strength
  2. ASTM B633.....Standard Specification for Electrodeposited Coatings of Zinc on Iron and Steel
  3. NYCCC.....New York City Construction Code.
  4. MFMA 103 .....Guidelines for the Use of Metal Framing.
  5. MFMA 4 .....Metal Framing Standards Publication.

### 1.05 SUBMITTALS

- A. Contractor shall submit Shop Drawings and material specifications for approval of the Engineer. Submittals shall include, but not be limited to the following:
  1. Manufacturer's catalog cuts for the supporting devices proposed for use with specifications and other data required to demonstrate compliance with the specified requirements.
  2. Scaled Shop drawings showing dimensions and locations of all items and clearance requirements.
  3. Support design details and equipment seismic anchorage and restraint details, stamped by a licensed Engineer as required.

### 1.06 QUALITY ASSURANCE

- A. General:
  1. All channels, fittings and hardware used in the supporting system shall be in accordance with MFMA 4 and MFA 103.
  2. The design of the support system shall be the responsibility of the Contractor. The Contractor shall provide the proper sized rods, channels, fittings, brackets and appurtenances necessary to adequately support the equipment.
  3. The Contractor shall retain the services of a Licensed Engineer, registered in the State of New York, to prepare support details for equipment

exceeding 50 pounds in weight. The Engineer shall stamp the support system design details.

**B. Seismic Requirements:**

1. Equipment assemblies such as secondary unit substations, switchgear, transformers, motor control centers and panelboards shall be certified to meet seismic requirements of the New York City Building Code.
2. The Contractor shall provide equipment anchorage details for all equipment certified to meet seismic requirements. The details shall be coordinated with the manufacturer's equipment mounting provisions.
3. Electric conduit shall include seismic restraints in accordance with the requirements of General Specification 16131 - Electric Conduit System.
4. The Contractor shall retain the services of a Licensed Engineer, registered in the State of New York, to prepare the seismic anchorage and restraint details. The Engineer shall stamp the seismic anchorage and restraint details.

**1.07 DELIVERY, STORAGE AND HANDLING**

- A. The supporting devices shall be delivered, stored and handled in accordance with the Detailed Specifications and the manufacturer's recommendations.

**PART 2 PRODUCTS**

**2.01 MANUFACTURERS**

- A. Supporting devices shall be as manufactured by:
1. B-Line, Highland, IL.
  2. Thomas and Betts Kindorf, Memphis, TN.
  3. Or approved equal.

**2.02 CHANNELS, FITTINGS AND BRACKETS**

- A. The Contractor shall provide channels, fittings, brackets and related hardware for mounting and supporting the electrical equipment. Anchor bolts, concrete inserts and related hardware for proper support of equipment shall also be provided. All equipment necessary to meet the seismic requirements specified shall be provided.
- B. Channels shall conform to ASTM A1011/A1011M. Channels shall have a minimum thickness of 12 gauge. The cross sectional width dimension shall be 1-1/2 inch minimum. The depth shall be as required to satisfy load requirements.

- C. Attachment holes, when required, shall be factory punched on hole centers approximately equal to the cross sectional width and shall be 9/16 inch diameter.
- D. Fittings and brackets shall have 9/16 inch diameter holes on centers identical to the channel or as required to align with the channel holes. Fittings and brackets shall have the same width as the channel and shall be 1/4 inch thick minimum. Fittings and brackets shall mate properly with the channel.
- E. All channels, fittings, brackets and related hardware shall be steel and have an electro-plated zinc finish according to ASTM B633.
- F. In corrosive areas, channels, fittings, brackets and related hardware shall be type 316 stainless steel or PVC coated.

2.03 CONDUIT HANGERS, SUPPORTS AND INSERTS

- A. The Contractor shall provide channels, rods, straps, anchors and related hardware for support of the exposed electric conduit system.
- B. The Contractor shall also provide anchor bolts, concrete inserts and related hardware for proper support of equipment. All equipment necessary to meet the seismic requirements specified shall be provided.
- C. Conduit hangers, supports and inserts shall be in accordance with General Specification 16131 - Electric Conduit System.

PART 3 EXECUTION

3.01 INSTALLATION

- A. All supporting devices shall be installed level, parallel and perpendicular to building walls and floors, such that the support system is installed in a neat and professional manner.
- B. All holes in hung ceilings for support rods and other equipment shall be made adjacent to bars where possible, to facilitate removal of ceiling panels.
- C. The channels, fittings and brackets shall be rigidly bolted together and braced to make a substantial supporting framework support system.
- D. Where motor control centers, switchgear, unit substations and other electrical equipment is being installed on concrete pads, the Contractor shall furnish leveling channels to the General Contractor. The General Contractor shall install the leveling channel in the concrete pads. Seismic certified equipment shall be anchored in accordance with the seismic anchorage details.
- E. All equipment fastenings to steel columns, beams and trusses shall be by beam clamps. In lieu of beam clamps, equipment may be welded to steel structures, subject to Engineer approval.
- F. No holes shall be drilled in any steel columns, beams and trusses.



## **GENERAL SPECIFICATION 16071 – SUPPORTING DEVICES**

---

- G. Hanger rod supports shall be installed such that threaded rod is parallel and perpendicular to building walls and floors.

END OF SECTION

NO TEXT ON THIS PAGE

**SECTION 16076  
Labeling and Identification**

**PART 1 GENERAL**

**1.01 SECTION INCLUDES**

- A. Requirements for providing labeling and identification. Labeling and identification shall be provided in accordance with the requirements specified under this section, the Detailed Specifications and the Contract Drawings.
- B. The labeling and identification shall be provided for the identification of equipment. The work shall include providing all voltage signs, equipment nameplates, markers arc flash labels and tags for all equipment furnished under this Contract
- C. The following index of this Section is included for convenience:

<u>Article</u>	<u>Title</u>	<u>Page</u>
		16076-
PART 1	GENERAL.....	1
1.01	Section Includes.....	1
1.02	Payment.....	1
1.03	Related Sections.....	2
1.04	References.....	2
1.05	Submittals.....	2
1.06	Quality Assurance.....	3
1.07	Delivery, Storage And Handling.....	3
PART 2	PRODUCTS.....	3
2.01	High Voltage Signs.....	3
2.02	Equipment Nameplates.....	3
2.03	Conduit Markers And Tags.....	4
2.04	Cable And Wire Markers.....	4
PART 3	EXECUTION.....	5
3.01	Installation.....	5

**1.02 PAYMENT**

- A. Payment for labeling and identification shall be made as provided for in the Detailed Specifications.

## GENERAL SPECIFICATION 16076 - LABELING AND IDENTIFICATION

### 1.03 RELATED SECTIONS

- A. General Specification 15076 - Piping and Equipment Identification
- B. General Specification 16055 - Shock Hazard and Arc Flash Studies
- C. General Specification 16121 - Low-Voltage Wires, Cables and Accessories.
- D. General Specification 16124 - Medium-Voltage Wires, Cables and Accessories.
- E. General Specification 16131 - Electric Conduit System
- F. General Specification 16292 - Power Distribution System Coordination

### 1.04 REFERENCES

- A. Labeling and identification shall comply with the latest applicable provisions and recommendations of the following:
  - 1. NYCEC - New York City Electrical Code.
  - 2. NFPA 70 - National Electrical Code.
  - 3. NFPA 70E - Standard for Electrical Safety in the Workplace
  - 4. IEEE 1584 - IEEE Guide for Performing Arc-Flash Hazard Calculations
  - 5. ANSI Z535.4 - American National Standard for Product Safety Signs and Labels
  - 6. NYC DEP BWT - Arc Flash Personal Protective Equipment BWT Guidelines.
  - 7. OSHA 1910 Subpart S - Electrical

### 1.05 SUBMITTALS

- A. Contractor shall submit Shop Drawings and material specifications for the approval of the Engineer. Submittals shall include but not be limited to:
  - 1. Prior to equipment submission, submit a list of proposed manufacturers with the products they produce proposed for the contract.
  - 2. Submit signs, nameplates and other labeling and identification devices proposed for use with specifications and other data required to demonstrate compliance with the specified requirements.

## **GENERAL SPECIFICATION 16076 - LABELING AND IDENTIFICATION**

---

### 1.06 QUALITY ASSURANCE

- A. All labeling and identification signs and nameplates shall be provided in accordance with the NYCEC, NFPA 70E and OSHA 1910 Subpart S.

### 1.07 DELIVERY, STORAGE AND HANDLING

- A. The labeling and identification devices shall be delivered, stored and handled in accordance with the Detailed Specifications and the manufacturer's recommendations.

## PART 2 PRODUCTS

### 2.01 HIGH VOLTAGE SIGNS

- A. High voltage signs shall be provided for equipment operating over 600 volts.
- B. High voltage signs shall be fiberglass reinforced polyester, rigid acrylic or aluminum plate 1/16-inch thick. Finish shall be industry standard of red, white and black graphics. Signs shall be 10 inches by 14 inches with the following exceptions:
  - 1. Use 7-inch by 10-inch signs where this is the largest size that can be applied.
  - 2. Use 14-inch by 20-inch signs where needed for adequate vision.
- C. High voltage signs shall read; "DANGER - HIGH VOLTAGE KEEP OUT".
- D. High voltage sign mounting screws shall be 3/16 inch diameter, round head, stainless steel, and self-tapping type.

### 2.02 EQUIPMENT NAMEPLATES

- A. Equipment nameplates shall be provided in addition to the manufacturer's nameplate, to identify the equipment number and the item's function and the equipment to which it serves.
- B. Equipment nameplates shall be provided in accordance with the requirements specified under Article 2.02 and General Specification 15076 - Piping and Equipment Identification.
- C. Equipment nameplates shall be laminated plastic with black letters on a white background. Nameplates for equipment identification shall have 1/2-inch high letter engravings. Nameplates for pilot device identification shall have 1/4-inch high letter engravings.
- D. Nameplates for distribution equipment shall have the following information:

## **GENERAL SPECIFICATION 16076 - LABELING AND IDENTIFICATION**

---

1. Equipment name and number.
  2. Voltage.
  3. Phases and number of wires.
- E. Pull boxes, junction boxes and control stations shall have a nameplate identifying the equipment name and number.
- F. All feeders and branch circuit devices shall have nameplates identifying the served equipment name and number. Where execution of the work under this Contract requires certain feeders and branch circuit devices to be modified, the Contractor shall provide new nameplates reflecting the modifications. The nameplates shall identify the served equipment name and number.
- G. All control and indicating devices shall have individual nameplates identifying device function.
- H. Nameplate mounting screws shall be 3/16 inch diameter, round-head, stainless steel and self-tapping type. Adhesives shall not be used.

### **2.03 CONDUIT MARKERS AND TAGS**

- A. Conduit markers and tags shall be provided for the identification of the electric conduit system.
- B. Conduit markers and tags shall be in accordance with General Specification 16131 - Electric Conduit System.

### **2.04 CABLE AND WIRE MARKERS**

- A. Cable and wire markers shall be provided for the identification of the electric wire and cable.
- B. Cable and wire markers shall be in accordance with General Specification 16121 - Electric Wire and Cable.

### **2.05 ARC FLASH LABELS**

- A. Labels shall be provided in addition to the manufacturer's nameplate and equipment nameplate, to identify equipment name, bolted fault and arcing fault current levels, flash protection boundary distances, working distances, personal-protective equipment classes and AFIE (Arc Flash Incident Energy) levels.
- B. Labels shall be able to withstand their usage environment, the print shall not fade, and adhesive should be aggressive enough to avoid peeling. The arc flash labels shall be printed on a durable polyester base over-laminated to protect the text and graphics. The back of the labels shall employ an acrylic adhesive, which allows the labels to be securely and permanently affixed to a wide range

## **GENERAL SPECIFICATION 16076 - LABELING AND IDENTIFICATION**

---

of surfaces. Labels shall include no field markings. Labels shall be generally in accordance with ANSI Z535.4.

- C. Labels shall include at a minimum the following information based on the Arc Flash Hazard Analysis performed:
  - 1. Nominal Voltage of the Equipment
  - 2. Flash Protection Boundary
  - 3. Personal Protective Equipment category at the working distance
  - 4. Arc Flash Incident Energy Value (cal/cm<sup>2</sup>) at the working distance
  - 5. Limited and Restricted Boundaries
  - 6. Study Report Number and Issue Date
  - 7. Location of Study Report
- D. Arc flash labels shall be provided in the following manner and all labels shall be based on recommended overcurrent device settings:
  - 1. For the 208 Volt panelboard, one arc flash label shall be provided.
  - 2. For the control panel enclosure, arc flash label shall be provided on each main.
- E. Arc flash labels shall be as manufactured by Brady or equal to be approved by the Engineer and comply with New York City DEP, Bureau of Wastewater Treatment (BWT) requirements.

### **PART 3 EXECUTION**

#### **3.01 INSTALLATION**

- A. All signs, nameplates and tags shall be installed neatly, properly and as recommended by the manufacturers.
- B. Signs and nameplates shall be mounted with screws. Where mounting of signs or nameplates with screws is impractical, the Contractor shall alert the Engineer.
- C. High voltage signs shall be installed on equipment operating at over 600 volts. High voltage signs shall also be installed on sides of fences or walls which enclose outdoor equipment operating at over 600 volts.

## **GENERAL SPECIFICATION 16076 - LABELING AND IDENTIFICATION**

- D. Control, signal and status wire and cable shall be identified by a unique number. The numbering system shall reflect the actual identification used in the work and shall be documented on the point-to-point wiring diagrams.

END OF SECTION



**GENERAL SPECIFICATION 16121 – LOW-VOLTAGE WIRES, CABLES AND ACCESSORIES**

---

**SECTION 16121  
Low-Voltage Wires, Cables and Accessories**

**PART 1 GENERAL**

**1.01 SECTION INCLUDES**

- A. Requirements for providing low-voltage electric wires, cables and accessories.
  - 1. Low-voltage electric wires, cables, and accessories shall be provided in accordance with the requirements specified under this Section, the Specifications and the Contract Drawings.
- B. Low-voltage electric wires and cables to be provided shall include all accessories.
- C. The following index of this Section is presented for convenience:

<u>Article</u>	<u>Title</u>	<u>Page</u>
		16121-
PART 1	GENERAL.....	1
1.01	Section Includes.....	1
1.02	Payment.....	1
1.03	Related Sections:.....	1
1.04	References.....	2
1.05	Submittals.....	3
1.06	Quality Assurance.....	4
1.07	Delivery, Storage And Handling.....	5
PART 2	PRODUCTS.....	5
2.01	Low- Voltage Wire And Cable.....	5
2.02	Low Voltage Wire And Cable Accessories.....	8
2.03	Shop Tests.....	10
PART 3	EXECUTION.....	10
3.01	General.....	10
3.02	Installation Of Wires And Cables.....	11
3.03	Conductor Identification.....	11
3.04	Low-Voltage Wire And Cable Field Testing.....	12

**1.02 PAYMENT**

- A. Payment for low-voltage wires and cables shall be made as provided for in the Detailed Specifications.

**1.03 RELATED SECTIONS:**

- A. General Specification 16010 – General Electrical Requirements
- B. General Specification 16061 – Grounding
- C. General Specification 16076 – Labelling and Identification.

## GENERAL SPECIFICATION 16121 – LOW-VOLTAGE WIRES, CABLES AND ACCESSORIES

---

### D. General Specification 16900 – Cable and Conduit Schedules

#### 1.04 REFERENCES

##### A. Definitions

1. Low-voltage as used in this Section and the Specifications shall mean all equipment, conductors, insulation systems and accessories intended for operation within the 600 Volt Class.
2. Low-voltage wires and cables shall mean all insulated electric wires and cables intended for use for power, lighting, control, instrumentation, communication, security and alarm circuits.
3. Low-voltage wires and cable accessories shall mean all devices and items intended to provide mechanical protection, terminate, connect, splice, insulate, tag and manage low-voltage wires and cables.
4. Cable is an assembly of insulated wires combined with fillers and separators in an enclosing jacket of insulating material.
5. All references to the Electric Utility or Utility shall mean Consolidated Company or the Local Electric Utility having jurisdiction.

##### B. Reference Standards

##### C. Low-voltage wires and cables shall comply with the latest applicable provisions and recommendations of the following:

- |    |               |   |  |
|----|---------------|---|--|
| 1. | NYCEC         | - | NYC Electrical Code  |
| 2. | NYCCC         | - | NYC Construction Code  |
| 3. | NFPA 72       | - | National Fire Alarm Code   |
| 4. | IEEE C2       | - | National Electrical Safety Code.   |
| 5. | ASTM B8       | - | Specification for Concentric-Lay-Stranded Copper Conductors, Hard, Medium-Hard, or Soft.                                   |
| 6. | ASTM D69      | - | Standard Test Methods for Friction Tape  |
| 7. | ASTM D2301    | - | Standard Specification for Vinyl Chloride Plastic Pressure-Sensitive Electrical Insulating Tape.                           |
| 8. | ASTM D3005    | - | Standard Specification for Low-Temperature Resistant Vinyl Chloride Plastic Pressure-Sensitive Electrical Insulating Tape. |
| 9. | ICEA S-58-679 | - | Standard for Control, Instrumentation and Thermocouple Extension Conductor Identification.                                 |

**GENERAL SPECIFICATION 16121 – LOW-VOLTAGE WIRES, CABLES AND ACCESSORIES**

---

- 10. IEEE 1210 - Standard Tests for Determining Compatibility of Cable-Pulling Lubricants with Wire and Cable.
- 11. ANSI/ICEA S-95-658/  
NEMA WC70 - Power Cables Rated 2000 V or Less for the Distribution of Electrical Energy.
- 12. NEMA WC26/  
EEMAC 201 - Binational Wire and Cable Packing Standard.
- 13. UL Standard No. 44 - Thermoset-Insulated Wires and Cables.
- 14. UL Standard No. 83 - Thermoplastic-Insulated Wires and Cables.
- 15. UL Standard 486A-486B - Wire Connectors
- 16. NETA ATS - NETA Acceptance Testing Specifications.

1.05 SUBMITTALS

- A. Contractor shall submit Shop Drawings and material specifications for the approval of the Engineer. Submittals shall include, but not be limited to:
  - 1. A list of proposed manufacturers shall be submitted with the products they produce proposed for the contract.
  - 2. Manufacturer's Literature, specifications and engineering data for low-voltage wires, cables and accessories including but not limited to:
    - a. Manufacturer and type of wire or cable.
    - b. Minimum insulation resistance in megaohms per 1,000 ft. at 20 degrees C.
    - c. Material, number and size of strands composing each conductor.
    - d. Conductor insulation thickness in inches with material and voltage rating.
    - e. Jacket thickness in inches.
    - f. Average outside diameter of bare conductor.
    - g. Average outside diameter of finished wire or cable and jacket material.
    - h. Weight per 1,000 ft. of finished wire or cable.
    - i. Minimum bending radius, in inches.
    - j. Minimum pulling temperatures at which cable may be pulled without damage.

## GENERAL SPECIFICATION 16121 – LOW-VOLTAGE WIRES, CABLES AND ACCESSORIES

---

- k. Maximum pulling tensions which may be applied to the cable without damage.
  - l. Literature identifying the methods and materials which Contractor proposes to use to make splices and terminations. Submittal shall consist of manufacturer's literature evidencing compatibility of the conductor insulation and jacket of the wire or cable with the splicing or terminating materials and methods which Contractor proposes to use.
  - m. Manufacturer recommended pulling lubricants.
  - n. Qualifications of splicing and termination personnel.
- 3. Description of shop and field testing methods, procedures and apparatus with calibration dates shall be submitted. Testing methods and procedures shall be submitted at least 45 days in advance prior to conformation of witness testing dates and actual testing.
  - 4. Qualifications of proposed testing firm to perform acceptance testing shall be submitted. Submit firm experience records at least 45 days in advance to actual testing, five recent references with phone numbers shall be submitted.
  - 5. Qualifications of proposed mineral-insulated metal sheath cable installer shall be submitted. Submit installer experience records with five recent completed installations with names and phone numbers.
  - 6. Certification from the mineral-insulated metal sheath cable manufacturer's representative that the cable installation is in accordance with the manufacturer's requirements.
- B. Reports:
- 1. Shop and field test reports shall be submitted.
  - 2. Acceptance testing report shall be submitted.

### 1.06 QUALITY ASSURANCE

#### A. General:

- 1. All low-voltage wires, cables and accessories shall be made by an approved manufacturer, and in their construction shall be employed the most improved commercial materials and processes of manufacture.
- 2. Only low-voltage wires, cables and accessories manufactured under high standards of production and meeting the approval of the Engineer shall be used.
- 3. Friction tape shall be in accordance with ASTM. D69.

**GENERAL SPECIFICATION 16121 – LOW-VOLTAGE WIRES, CABLES AND ACCESSORIES**

---

4. All low-voltage wire and cable splicing and terminations shall be done by experienced cable splicers who have worked with similar wire and cable for a period of at least 5 years, using materials and procedures recommended by the wire and cable manufacturer. All splicing and terminations of low-voltage wire and cable shall be in accordance with the instructions of the low-voltage wire and cable manufacturer.
5. The low-voltage wire and cable manufacturer shall use a shop test facility that has recently calibrated testing apparatus and qualified, experienced technicians, for all shop tests. Calibration of testing apparatus shall be within one year.
6. All test equipment and instrument calibration shall be in accordance with the latest edition of the accuracy standard of the U.S. National Institute of Standards and Technology and the NETA acceptance testing specification.
7. The mineral-insulated metal sheath cable installation shall be performed by experienced mineral-insulated metal sheath cable installers who shall have been regularly engaged in the installation of mineral-insulated metal sheath cable for a minimum of the past three years.
8. The Contractor shall retain the services of the mineral-insulated metal sheath cable manufacturer's representative to certify the cable installation is in accordance with the manufacturer's requirements.

**B. Field Tests:**

1. Low-voltage wires and cables shall be field tested. Field testing low-voltage wires and cables shall be in accordance with the requirements specified under Article 3.04.
2. The Contractor shall retain the services of an independent testing firm who shall perform acceptance testing on the low-voltage wire and cable installation. The testing firm shall have experience in the inspection and testing of wires and cables of the type specified and shall be a member company of NETA. Provide proof of membership or demonstrate that the standards and experience required for membership are possessed, all to the satisfaction of the Engineer. The testing shall be performed in accordance with the requirements specified under Article 3.05.

**1.07 DELIVERY, STORAGE AND HANDLING**

- A. Electric wires and cables shall be delivered, stored and handled in accordance with the Detailed Specifications and the manufacturer's instructions.

**PART 2 PRODUCTS**

**2.01 LOW-VOLTAGE WIRE AND CABLE**

- A. Low-voltage wire and cable shall be used for all power, lighting, control instrumentation, alarm and security system circuits. The size and quantity of low-

## GENERAL SPECIFICATION 16121 – LOW-VOLTAGE WIRES, CABLES AND ACCESSORIES

---

voltage wires and cables shall be as indicated in the conduit and cable schedule. The conductor jacket shall be in accordance with color identification requirements specified under Article 3.03.

- B. Low-voltage single conductor wires for installation in conduit shall be in accordance with the following:
1. Conductors shall be stranded, copper, single conductor wire conforming to ASTM B8, and B33 No. 12 AWG minimum size.
  2. Conductor insulation shall be flame-retardant, moisture and heat resistant thermoset rated 90 degrees C in dry locations and 75 degrees C in wet locations and listed by UL as type XHHW-2 or RHW.
  3. XHHW-2 shall be used for all indoor circuits and RHW for all underground and outdoor circuits.
  4. Low-voltage single conductor wires for installation in conduit shall be as manufactured by:
    - a. Southwire, Carrollton, GA.
    - b. General Cable, Highland Heights, KY
    - c. Okonite Company, New York, NY.
    - d. Or approved equal.
- C. Low-voltage cable for installation in conduit shall be in accordance with the following:
1. Conductors shall be stranded, copper conforming to ASTM B8 and B33, No. 12 AWG minimum size.
  2. Conductor insulation shall be moisture and flame resistant cross-linked polyethylene rated 90 degrees C in wet and dry locations and listed by UL as type XHHW-2.
  3. Cable conductors shall be assembled together with flame and moisture resistant filters and tape to make round.
  4. Cable shall include an overall protective jacket of polyethylene compound, 45 mils minimum thickness.
  5. Low-voltage cable shall be as manufactured by:
    - a. Southwire, Carrollton, GA.
    - b. General Cable, Highland Heights, KY
    - c. Belden,
    - d. Okonite Company, New York, NY.
    - e. Or approved equal.

**GENERAL SPECIFICATION 16121 – LOW-VOLTAGE WIRES, CABLES AND ACCESSORIES**

---

- D. Instrumentation cable shall in addition comply with the following:
  - 1. Conductors shall No 16 AWG minimum size
  - 2. All conductors shall be polyethylene insulated and twisted in pairs with aluminum-mylar shield overlap.
  - 3. Cable jacket shall be low halogen
- E. Communication cable shall in addition comply with the following:
  - 1. Conductors shall be No 24 AWG minimum size.
  - 2. Conductor twist and shielding shall be as shown on the Contract Drawings or as stated in the Detailed Specifications.
  - 3. Cable jacket shall be low halogen
- F. Fire Alarm cable shall in addition comply with the following:
  - 1. Conductors shall 18 AWG minimum size
  - 2. Cables shall be UL listed for the intended service
  - 3. Cables intended for use in the installation shall be approved for the intended use by the New York City Building Department, Material and Equipment Acceptance Division.
- G. Security system cable shall in addition comply with the following:
  - 1. Conductors shall be No 22, AWG minimum size.
  - 2. Conductor twist and shielding shall be as shown on the Contract Drawings or as stated in the Detailed Specifications.
  - 3. Coaxial cable shall be as shown on the Contract Drawings or as stated in the Detailed Specifications.
- H. Mineral-insulated metal sheath cable shall be used for the fire pump circuits. The mineral-insulated metal sheath cable shall be in accordance with the following:
  - 1. The mineral-insulated metal sheath cable shall be NYCEC, type MI. The cable assembly shall be UL listed including support for a 2-hour fire rating.
  - 2. Conductors shall be solid copper conforming to ASTM B5.
  - 3. Cable insulation shall be magnesium oxide mineral rated 600 volts, 90 degrees C. The cable shall include a metal-sheath consisting of seamless soft drawn copper.
  - 4. The cable shall be provided with all fittings and hardware necessary for proper installation.
  - 5. The mineral-insulated metal sheath cable shall be as manufactured by:
    - a. Pentair Pyrotenax, Houston, TX.

## GENERAL SPECIFICATION 16121 – LOW-VOLTAGE WIRES, CABLES AND ACCESSORIES

---

- b. AFC Cable Systems, New Bedford, MA.
- c. Or approved equal.

### 2.02 LOW-VOLTAGE WIRE AND CABLE ACCESSORIES

- A. Cable connectors shall be provided for terminating low-voltage wire and cable. Connectors shall be solder less type and properly sized to fit fastening device and wire size. Connectors shall be in accordance with the following:
  - 1. For wire sizes up to and including No. 6 AWG, compression type with UL 486A listing shall be used. All cable terminations for conductors No. 10 AWG and smaller shall be terminated using UL listed ring tongue type, nylon insulated connectors, at each terminal board.
  - 2. For wire sizes No. 4 AWG and above, either compression type or bolted type with tin-plated contact faces shall be used.
  - 3. For wire sizes No. 250 kcmil and larger, connectors with at least 2 cable clamping elements or compression indents and provision for at least 2 bolts for joining to apparatus terminal shall be used.
  - 4. Compression connectors shall be Power-Connect, ring tongue shall be Series 83 as manufactured by:
    - a. Ideal Industries, Sycamore, IL.
    - b. Thomas and Betts, Memphis, TN.
    - c. Burndy, Manchester, NH.
    - d. Or approved equal.
- B. Splicing for low-voltage wire and cable shall be performed when terminals are not provided. Splicing shall be in accordance with the following:
  - 1. For wire sizes No. 8 AWG and larger, splices shall be made up with compression type copper splice fittings with UL 486A listing. Splices shall be taped and covered with materials recommended by the cable manufacturers, to provide insulation equal to that on the conductors.
  - 2. For wire sizes No. 10 AWG and smaller, splices shall be made up with preinsulated spring connectors. Connectors shall be flame retardant with UL listing.
  - 3. For wet locations, splices shall be waterproofed. Compression type splices shall be waterproofed by a sealant-filled, thick wall, heat shrinkable, thermosetting tubing or by pouring a thermosetting resin into a mold that surrounds the joined conductor. Waterproof compression splices shall be UL listed, heavy wall type. Spring connector splices shall be UL listed and waterproofed with a sealant-filler.



**GENERAL SPECIFICATION 16121 – LOW-VOLTAGE WIRES, CABLES AND ACCESSORIES**

---

4. Compression splices shall be manufactured by:
    - a. Ideal Industries, Sycamore, IL.
    - b. Thomas and Betts, Memphis, TN.
    - c. Burndy, Manchester, NH.
    - d. Or approved equal.
  5. Waterproof compression splices shall be thermo-shrink as manufactured by
    - a. Ideal Industries, Sycamore, IL.
    - b. Thomas and Betts, Memphis, TN.
    - c. Burndy, Manchester, NH.
    - d. Or approved equal.
  6. Spring connector splices shall be Twister type and Twister DB type for waterproof, as manufactured by:
    - a. Ideal Industries, Sycamore, IL.
    - b. Thomas and Betts, Memphis, TN.
    - c. Burndy, Manchester, NH.
    - d. Or approved equal.
- C. Cable markers shall be provided for the identification of low-voltage wire and cable. Markers shall be in accordance with the following:
1. Markers shall be vinyl type, moisture, heat and abrasion resistant with adhesive back. Cable identification shall be clearly marked.
  2. Markers shall be as manufactured by:
    - a. Ideal Industries, Sycamore, IL.
    - b. Thomas and Betts, Memphis, TN.
    - c. Brady, Milwaukee, WI.
    - d. Or approved equal.
- D. Low-voltage wire and cable pulling lubricant shall be used to reduce wire and cable tension and sidewall pressure and aid in minimizing damage during low-voltage wire and cable installation. Pulling lubricant shall be in accordance with the following:
1. UL Listed, compatible with the wire insulation or cable jacket, the raceway involved and acceptable to the wire and cable manufacturer. When wire and cable manufacturer shall be provided.

## GENERAL SPECIFICATION 16121 – LOW-VOLTAGE WIRES, CABLES AND ACCESSORIES

---

2. Pulling lubricant shall be water based, with a 0.17 average coefficient of friction and a temperature range of 20 to 120 degrees F.
3. Pulling lubricant shall conform to IEEE 1210
4. Pulling lubricant shall not support combustion.
5. Pulling lubricant shall not cause residue to cement insulation or jackets to the inside of conduit or ducts.
6. Pulling lubricant shall be as manufactured by:
  - a. American Polywater Corporation, Stillwater MN
  - b. 3M – St. Paul, MN
  - c. Ideal Industries, Sycamore, IL.
  - d. Or approved equal.

### 2.03 SHOP TESTS

#### A. Certified Shop Tests:

1. Shop testing shall be performed on the low-voltage wire and cable at the manufacturer's plant prior to shipment. Shop test shall be in accordance with the latest revisions of ICEA and UL and shall demonstrate that the wire and cable tested conforms to the requirements specified.
2. The Contractor shall provide a shop test report. The report shall identify the tests performed and the results obtained.
3. All low-voltage wire and cable shall be shop tested in accordance with the requirements of the Detailed Specifications.

#### B. Witnessed Shop Tests:

1. The Contractor shall perform witnessed shop tests in accordance with the Detailed Specifications.
2. The Engineer shall have access during working hours for inspection purposes to all parts of the works where material and cable are being manufactured, and all reasonable inspection and testing facilities shall be provided to him without increase in price. The Engineer may request that dielectric strength tests and measurements be made to verify the cable data furnished by the Contractor. For this purpose the Contractor shall furnish without increase in price, a length of cable, not to exceed 3 feet for each size to be cut from one or more reels as directed by the Engineer. Each sample shall be marked with a tag bearing full description of cable insulation and number of reel from which it is cut.

**GENERAL SPECIFICATION 16121 – LOW-VOLTAGE WIRES, CABLES AND ACCESSORIES**

---

**PART 3 EXECUTION**

**3.01 GENERAL**

- A. All low-voltage wires and cables shall be installed within the raceways as shown on the Contract Drawings. They shall be carefully handled so as to avoid twists or kinks in the conductors or damage to the insulation.
- B. The Contractor shall ensure that the manufacturer's recommended cable bending radii and pulling are not exceeded and that the number of conductors permitted in a conduit are in accordance with the latest applicable section of the New York City Electrical Code.
- C. No splices shall be permitted between terminals except at approved junction or terminal boxes. Boxes shall be provided as shown on the Contract Drawings or as required by Code for the pull lengths. No more than two terminations shall be made at each terminal point. Cable and wire runs shall be looped through pull boxes without cutting and splicing where possible. All splices below grade, in manholes, hand holes and wet locations shall be waterproofed.
- D. No splicing of instrument wiring shall be permitted. Instrument wiring shall be extended by use of field termination boxes employing labeled terminal strips. Shield continuity shall be maintained. Ultimate shield termination (ground) shall be at one end only.
- E. The mineral-insulated metal sheath cable manufacturer's representative shall review the cable installation to certify that the cables are installed in accordance with the manufacturer's requirements.

**3.02 INSTALLATION OF WIRES AND CABLES**

- A. Cables shall be installed complete with proper terminations at both ends. For each motor circuit, Contractor shall ensure proper phasing, phase sequence and motor rotation.
- B. Wire and cable contained within a single conduit shall be pulled simultaneously using insulating pulling compounds containing no mineral oil.
- C. Pulling tension on wires and cables shall be continuously monitored using a calibrated Dynamometer type device, having a calibration label within six months of its use.
- D. Cables shall be installed with maximum slack at all terminal points, boxes, handholes and manholes.
- E. Low-voltage cables located within manholes, handholes and boxes shall be wrapped with fireproofing tape for their entire length on an individual cable basis. Tape shall be 30 mills thick of self-extinguishing material which will not support combustion. Tape shall not deteriorate when subjected to water, salt, sewage or fungus and shall be secured with glass cloth tape. Low-voltage cables shall be

**GENERAL SPECIFICATION 16121 – LOW-VOLTAGE WIRES, CABLES AND ACCESSORIES**

---

fireproofed in accordance with the cable manufacturer's recommendations and then covered with tape extending at least one inch into any duct.

**3.03 CONDUCTOR IDENTIFICATION**

- A. Each conductor shall be labeled at each termination point and all splice locations. Carry individual conductor or circuit identification throughout, with circuit numbers or other identification stamped on terminal boards when provided or the cable so it is visible around the cable's circumference.
- B. Each conductor shall be identified in junction boxes, cabinets, and terminal boxes. Where no termination is made, use a plastic-coated, self-adhesive, wire marker. Where termination is made, use a plastic, pre-printed sleeve wire marker. Paper, self-adhesive wire markers shall not be used.
- C. In manholes and handholes, each power conductor shall be identified by a laminated plastic tag located so that it can be seen from center of manhole without moving adjoining wires. Bundle and mark control wires as listed in conduit and cable schedule.
- D. Multi-conductor control cables shall be color coded in accordance with ICEA S-58-679, Method 1, Table E
- E. The following identification scheme shall be used for all low-voltage power circuits:

Voltage	Colors				
	Neutral Conductor	Phase A Conductor	Phase B Conductor	Phase C Conductor	Ground Conductor
208/120V	White	Black	Red	Light Blue	Green
240/120V	White-Gray Strip	Black-Blue Strip	RED-BLUE STRIP	None	Green
480/277V	Gray	Brown	Orange	Yellow	Green

**3.04 LOW-VOLTAGE WIRE AND CABLE FIELD TESTING**

- A. After installation, all low-voltage wire and cable shall be field tested. The field tests shall be performed by the Contractor who shall furnish all testing equipment. The field tests shall be witnessed by the Engineer and certified by the Contractor. The Contractor shall provide a report identifying the tests performed and the results obtained.
- B. Each electrical circuit shall be tested after permanent wires and cables are in place to demonstrate that the circuit and equipment are connected properly and will

## **GENERAL SPECIFICATION 16121 – LOW-VOLTAGE WIRES, CABLES AND ACCESSORIES**

---

perform satisfactorily, as required, as intended, and that they are free from improper grounds and short circuits. The tests shall consist of the following:

1. Low-voltage wire and cable mechanical connections shall be individually tested after installation and before they are put in service with a calibrated torque wrench. Values shall be in accordance with manufacturer's recommendations.
2. Low-voltage wires and cables shall be individually tested for continuity between the required termination points for each ungrounded and grounded conductor. Test wire and cable after installation and before first energization or before they are put in service with an approved continuity tester. Test results shall be as recommended by the wire and cable manufacturer or in accordance with NETA ATS, NEMA, ICEA Standards.
3. Low-voltage wires and cables shall be individually tested for insulation resistance between ungrounded and grounded conductors, and from each ungrounded and grounded conductor to ground. Test wire and cable after installation and before first energization or before they are put in service with an approved insulation resistance tester, for one minute at a voltage rating recommended by the cable manufacturer or in accordance with NETA ATS, NEMA, and ICEA Standards.
4. The insulation resistance for any given conductor shall not be less than the value recommended by the cable manufacturer or in accordance with NETA ATS, NEMA and ICEA Standards. Any cable not meeting the recommended value or which fails when tested under full load conditions shall be replaced with a new cable for the full length.
5. Shielded instrumentation cable shields shall be tested with an ohmmeter for continuity along the full length of the cable and for shield continuity to ground.
6. Connect Shielded instrumentation cables shall be connected to a calibrated 4-20 milliamp DC signal transmitter and receiver. Test at 4, 12, and 20 milliamp transmitter settings.

END OF SECTION

**GENERAL SPECIFICATION 16121 – LOW-VOLTAGE WIRES, CABLES AND  
ACCESSORIES**

---

NO TEXT ON THIS PAGE

**SECTION 16131  
Electric Conduit System**

**PART 1 GENERAL**

**1.01 SECTION INCLUDES**

- A. Requirements for providing conduit system. The conduit system shall be provided in accordance with the requirements specified under this section, the Detailed Specifications and the Contract Drawings.
- B. The conduit system required shall be provided with all rigid and flexible conduits, boxes, fittings, supports, hangers and inserts and other conduit accessories as required for the installation of the electric wire and cable.
- C. The following index of this Section is presented for convenience:

<u>Article</u>	<u>Title</u>	<u>Page</u>
		16131-
PART 1	GENERAL .....	1
1.01	SECTION INCLUDES .....	1
1.02	PAYMENT .....	1
1.03	RELATED SECTIONS .....	2
1.04	DEFINITIONS .....	2
1.05	REFERENCES .....	2
1.06	SUBMITTALS .....	3
1.07	DELIVERY, STORAGE AND HANDLING .....	3
PART 2	PRODUCTS .....	3
2.01	RIGID STEEL CONDUIT .....	3
2.02	HANGERS, SUPPORTS AND INSERTS .....	4
2.03	FLEXIBLE METALLIC CONDUIT .....	5
2.04	OUTLET BOXES AND FITTINGS .....	6
2.05	CONDUIT ACCESSORIES .....	7
2.06	TERMINAL, JUNCTION AND PULL BOXES .....	11
PART 3	EXECUTION .....	13
3.01	GENERAL .....	13
3.02	INSTALLATION OF RACEWAYS .....	14
3.03	CONDUIT CONNECTIONS TO EQUIPMENT .....	17
3.04	INSTALLATION OF BOXES AND FITTINGS .....	17
3.05	INSTALLATION WITHIN HAZARDOUS AREAS .....	18
3.06	FIELD TESTS .....	19

**1.02 PAYMENT**

- A. Payment for Electric Conduit System shall be made as provided in the Detailed Specifications.

## GENERAL SPECIFICATION 16131 - ELECTRIC CONDUIT SYSTEM

---

### 1.03 RELATED SECTIONS

- A. General Specification 05092 - Metal Fastening.
- B. General Specification 09900 - Painting.
- C. General Specification 15060 - Hangers and Supports.
- D. General Specification 16061 - Grounding

### 1.04 DEFINITIONS

- A. Conduit System: Shall mean a complete installation comprising all rigid conduit and flexible connections, boxes, fittings, supports, hangers, inserts and other conduit accessories as required for the installation of electric wires and cables.
- B. Conduit Accessories: Shall mean all fittings required to ensure a complete conduit system installation. Conduit accessories shall include, but is not limited to, expansion, deflection, seal and drain fittings, hubs, bushings, duct seal, tags, markers, thruwall seals and bushings.

### 1.05 REFERENCES

- A. Electric conduit system shall comply with the latest applicable provisions and recommendations of the following:
  - 1. NYCEC - New York City Electrical.
  - 2.
  - 3. IEEE 142 - Recommended Practice for Grounding of Industrial and Commercial Power Systems.
  - 4. UL 6 - Rigid Metal Electrical Conduit -Steel.
  - 5. UL 50 - Standard for Enclosures for Electrical Equipment.
  - 6. UL 360 - Standard for Liquid-Tight Flexible Metal Conduit.
  - 7. UL 514A - Metallic Outlet Boxes.
  - 8. UL 514B - Conduit, Tubing and Cable Fittings.
  - 9.
  - 10. ANSI C80.1 - Electric Rigid Steel Conduit.
  - 11. ASTM D870 - Standard Practice for Testing Water Resistance of Coatings Using Water Immersion.



## GENERAL SPECIFICATION 16131 - ELECTRIC CONDUIT SYSTEM

---

- 12. ASTM D1735 - Standard Practice for Testing Water Resistance of Coatings Using Water Fog Apparatus.
- 13. NEMA RN-1 - PVC Externally Coated Galvanized Rigid Steel Conduit and Intermediate Metal Conduit

### 1.06 SUBMITTALS

- A. Contractor shall submit Shop Drawings and material specifications for the approval of the Engineer. Submittals shall include, but not be limited to:
  - 1. A list of proposed manufacturers with the products they produce proposed for the contract.
  - 2. Manufacturer's catalog cuts for the conduit, boxes, fittings and supports proposed for use.
  - 3. Construction details of conduit racks and other conduit support systems with seismic restraint details and calculations signed by a licensed Engineer.
  - 4. Scaled Shop Drawings showing proposed routing of all conduits, inclusive of conduits embedded in structural concrete and conduits directly buried in earth.
  - 5. Scaled Shop Drawings showing locations of pull and junction boxes and all penetrations in walls and floor slabs.
  - 6. Field test report.

### 1.07 DELIVERY, STORAGE AND HANDLING

- A. Electric conduit system shall be delivered, stored and handled in accordance with the Detailed Specifications, the manufacturer's instructions and the following:
  - 1. Conduit shall be delivered to the work in standard bundles having each length suitably marked with the manufacturer's name or trademark and bearing the label of the Underwriters' Laboratories, Incorporated inspection service.

## PART 2 PRODUCTS

### 2.01 RIGID STEEL CONDUIT

- A. The Contractor shall provide rigid steel conduit. All steel conduit shall comply with the requirements of ANSI C80.1, and UL 6.

## GENERAL SPECIFICATION 16131 - ELECTRIC CONDUIT SYSTEM

---

- B. Both the inside and outside surfaces of the rigid steel conduit shall be protected against corrosion by a coating of zinc applied by the hot-dip galvanizing process.
- C. Conduits, elbows and couplings shall be rigid, heavy wall, mild steel, hot dip galvanized. Conduits, elbows and couplings shall have a smooth interior with tapered threads and carefully reamed ends. Conduit size shall be 3/4-inch minimum and shall conform to UL 6.
- D. Conduits, elbows and couplings shall include a PVC coating for all areas. For conduits located indoors in dry, dusty areas the use of rigid steel conduit without PVC coating shall be permitted.
- E. PVC coating of conduit shall be factory applied and shall include a smooth 2 mil thick urethane interior coating and 40 mil thick polyvinyl chloride exterior coating. PVC coated conduit shall conform to NEMA RN-1, ASTM D870, ASTM D1735 and UL 6. The exterior PVC coating color shall be gray and listed UL DYJC. The threads of conduits that have been cut in the field to size shall have the same PVC coating applied. .
- F. Rigid steel conduit shall be as manufactured by:
  - 1. Allied Tube and Conduit Corporation, Philadelphia, PA.
  - 2. Wheatland Tube Company, Sharon, PA.
  - 3. Republic Conduit, Louisville, KY.
  - 4. Or approved equal.
- G. PVC coated rigid steel conduit shall be as manufactured by:
  - 1. Robroy Industries, Gilmer, TX.
  - 2. OCAL by Thomas & Betts, Memphis, TN.
  - 3. Or approved equal

### 2.02 HANGERS, SUPPORTS AND INSERTS

- A. The Contractor shall provide hangers, supports and inserts for support of the electric conduit system. The supports shall securely attach the electric conduit system to the channel and structure.
- B. The electric conduit system shall be designed, constructed and installed suitable for earthquake regulations in accordance with the seismic requirements of the New York City Building Code and the Uniform Building Code for Zone 2A application.
- C. Transverse and longitudinal bracing shall be provided as required to brace the electric conduit for the seismic requirements specified.

## GENERAL SPECIFICATION 16131 - ELECTRIC CONDUIT SYSTEM

---

- D. All drilled in type concrete inserts shall be expansion shields or anchors conforming to General Specification 05092 - Metal Fastening and 15060 - Hangers and Supports. In corrosive locations, concrete inserts shall be 316 stainless steel.
- E. Hangers and supports shall be in accordance with the requirements of General Specification 15060 - Hangers and Supports except beam clamps, hanger rods and hardware shall be steel with electro-plated zinc finish. This shall also include bolts, nuts and washers. In corrosive locations, hangers and support hardware shall be type 316 stainless steel or factory applied 40 mil thick PVC coated.
- F. Hangers, Supports and Inserts shall be as manufactured by:
  - 1. B-Line by Eaton, Highland, IL.
  - 2. Kindorf, Harahan, LA.
  - 3. Or approved equal.

### 2.03 FLEXIBLE METALLIC CONDUIT

- A. The Contractor shall provide flexible metallic conduit where required to permit movement of connected devices and where it is impracticable to complete runs with rigid conduit.
- B. Flexible conduit used indoor in non-hazardous dry dusty areas shall be non-liquid-tight, with a steel core.
- C. Flexible conduit used outdoors and in non-hazardous, wet and corrosive areas shall be UL Listed and include a hot dipped galvanized steel core with a liquid-tight, polyvinyl chloride cover and shall include a built-in copper ground for sizes 3/4-inch through 1-1/4 inch.
- D. For hazardous areas flexible conduit shall include a brass inner core with a bronze outer braid and protective neoprene plastic coating. End fittings shall be steel, brass or bronze.
- E. Flexible conduit shall be as manufactured by:
  - 1. Anaconda American Brass Company, Rolling Meadows, IL.
  - 2. Electric-Flex Company, Roselle, IL.
  - 3. Or approved equal.
- F. Hazardous area flexible conduit shall be as manufactured by:
  - 1. Crouse Hinds Company, Syracuse, NY.
  - 2. Appleton Electric Company, Rosemont, IL.
  - 3. Or approved equal.

2.04 OUTLET BOXES AND FITTINGS

- A. The Contractor shall provide outlet boxes and fittings for rigid and flexible conduit. The outlet boxes and fittings required for the work which constitutes a part of the conduit system, shall be of approved types.
- B. Fittings, bodies and boxes installed on PVC coated conduits shall have interior and exterior PVC coatings equivalent and corresponding to that of the conduit on which they are installed
- C. For outdoor, wet and corrosive areas, conduit fittings and outlet bodies shall be cast gray iron alloy, cast malleable iron bodies and covers. All units shall be gasketed, watertight, and threaded with five full threads and shall have rust-proofing in accordance with the requirements of this Section.
- D. Threaded cast ferrous metal, hub type outlet boxes shall be used throughout, except in the interior walls of superstructures and in roof slabs protected by built-up roofing where pressed steel boxes shall be installed. Cast iron or alloy outlet boxes of the proper size and depths for the application, complete with watertight gaskets and covers secured by brass screws, shall be furnished and installed as indicated on the Contract Drawings or as required by the conduit run. Outlet boxes, furnished and installed for the installation of lighting fixtures, switches and receptacles in a future contract, shall be furnished with watertight gaskets and blank covers.
- E. For non-hazardous, indoor dry dusty areas pressed steel boxes of the proper size and depths for the application shall be provided. Boxes shall be rated NEMA 12, not less than No. 14 U.S. Standard Gauge (0.078 inch). The conduit openings shall be provided with oil-resistant gaskets. Conduits shall be fastened to these boxes with locknuts and bushings, and all unused outlets or holes shall be left sealed.
- F. All outlet boxes intended for the support of fixtures shall be provided with approved fixture studs.
- G. For concealed conduit runs in outside walls and all exposed conduit work, connections to boxes and fittings shall be made through threaded holes, unless otherwise approved by the Engineer. For concealed conduit work in non-hazardous areas in other than outside walls, connections between conduit and boxes may be made with drilled holes, using locknuts and bushings.
- H. Where necessary unions may be used. Unions in hazardous locations shall be type UNF, UNL or YNY by:
  - 1. Crouse-Hinds Syracuse, NY.
  - 2. Or approved equal.
- I. Unions in non-hazardous areas shall be universal or Erickson type by:
  - 1. Thomas & Betts, Memphis, TN.

2. Or approved equal.

- J. All boxes installed for concealed conduit, shall be provided with extension rings or plaster rings and covers as required. For non-hazardous, dry indoor areas stainless 302/304, satin beveled steel cover and device plates for surface mounted boxes shall be used. For corrosive locations, galvanized ferrous and galvanized cast ferrous metal cover and device plates with neoprene gaskets shall be used.
- K. Outlet boxes and fittings installed on PVC coated conduit shall also include interior and exterior coatings equivalent to the conduit.

2.05 CONDUIT ACCESSORIES

A. The Contractor shall provide conduit accessories for use with the conduit system. The conduit accessories shall be of approved types.

B. Expansion and Deflection Fittings:

- 1. Expansion and deflection fittings shall be made up of non-corrodible parts and shall provide for ample longitudinal and lateral movement. A suitable bond shall provide a low resistance, continuous longitudinal path for ground currents.
- 2. Expansion and deflection fittings shall be watertight cast iron, malleable iron or hot dipped galvanized. Fittings shall be corrosion-resistant, UL listed and compatible with the conduit system.
- 3. Expansion /deflection fittings shall provide both expansion and deflection in a single fitting in accordance with the following:
  - a. Axial expansion or contraction up to 3/4-inch.
  - b. Angular misalignment up to 30 degrees.
  - c. Parallel misalignment up to 3/4-inch.
- 4. Expansion fittings shall provide expansion /contraction with eight inch total movement.
- 5. Expansion and deflection fittings shall be as manufactured by:
  - a. Crouse-Hinds, Syracuse, NY.
  - b. Appleton Electric, Rosemont, IL.
  - c. Or approved equal.

C. Sealing Fittings:

- 1. Sealing fittings shall be cast gray iron alloy or cast malleable iron or copper free aluminum with zinc electroplate and lacquer or enamel finish.

## GENERAL SPECIFICATION 16131 - ELECTRIC CONDUIT SYSTEM

---

2. Sealing fittings shall have an ample opening with threaded closure for access to conduit hub for making dam. Sealing fiber and compound shall be suitable for use with the fitting and shall be the products of the fitting manufacturer.
  3. For corrosive locations, seal fittings shall include interior and exterior coatings equivalent to the PVC conduit coating specified under this Section.
  4. Sealing fittings shall be as manufactured by:
    - a. Crouse-Hinds, Syracuse, NY.
    - b. Appleton Electric, Rosemont, IL.
    - c. Or approved equal.
- D. Drain Fittings:
1. Drain fittings shall be a combination device designed to provide ventilation to minimize condensation and drains accumulated condensate.
  2. The combination drain/breather fitting shall be 3/8 inch male thread size with stainless steel body.
  3. Drain fittings shall be as manufactured by:
    - a. Crouse-Hinds, Syracuse, NY.
    - b. Appleton Electric, Rosemont, IL.
    - c. Or approved equal.
- E. Conduit Hubs:
1. Conduit hubs shall be threaded, insulated throat type with bonding screw locknut.
  2. The conduit hub and locknut shall be malleable iron or zinc and shall include a 90 degree C insulating surface and a sealing ring for a water tight and dust tight connection.
  3. Conduit hubs shall be as manufactured by:
    - a. O-Z/Gedney Rosemont, IL.
    - b. Thomas and Betts, Memphis, TN.
    - c. Or approved equal.
- F. Conduit Bushings:
1. Conduit bushings shall be insulated, grounding type with lay-in-lug connection. Two locknuts shall be provided for each bushing.

## GENERAL SPECIFICATION 16131 - ELECTRIC CONDUIT SYSTEM

---

2. The conduit bushing and locknuts shall be steel, malleable iron or zinc. The bushing shall include a 90 degrees C insulating surface.
  3. Conduit bushings and locknuts shall be as manufactured by:
    - a. O-Z/Gedney, Rosemont, IL.
    - b. Thomas and Betts, Memphis, TN.
    - c. Or approved equal.
- G. Duct Seal:
1. Duct seal shall be a suitable for forming a water and gas tight seal between cables and conduits.
  2. Completed seal shall be resistant to gasoline, oils, dilute acids and bases.
  3. The completed seal shall be capable of blocking water pressure of at least 10 psi.
  4. Duct seal shall be by
    - a. American Polywater Corp, Stillwater, MN
    - b. O-Z/Gedney, Rosemont, IL.
    - c. Ideal Industries, Sycamore, IL.
    - d. Or approved equal. .
- H. Thruwall Seals and Bushings:
1. Thruwall seals and bushings shall be in accordance with the following:
    - a. For conduits and cables in new construction and passing through exterior subsurface walls and exterior concrete walls, thruwall seals shall be used. Thruwall seals shall be Type WSK and WSCS as manufactured by:
      - 1) O-Z/Gedney Rosemont, IL.
      - 2) Or approved equal.
    - b. For conduits and cables in new construction and passing through concrete floors and floor slabs, floor seals shall be used. Floor seals shall be type SK and FSCS as manufactured by:
      - 1) O-Z/Gedney, Rosemont, IL.
      - 2) Or approved equal.
    - c. For conduits passing through exterior block walls or installed in existing construction passing through exterior subsurface walls, exterior concrete walls, floor slabs and roof slabs for use in core bit-drilled holes sealing bushings shall be used. Sealing bushings

shall be Type CSMI at the inside of the structure and Type CSMC at the outside of the structure, within the same core drilled hole. Sealing bushings shall be as manufactured by:

- 1) O-Z/Gedney, Rosemont, IL.
  - 2) Or approved equal.
- d. For conduits passing through existing interior concrete walls or floors and interior block walls sealing bushings shall also be used. Sealing bushings shall be CSMC or CSMI type as manufactured by:
- 1) O-Z/Gedney, Rosemont, IL.
  - 2) Or approved equal.
- e. For conduits passing through fire rated floors and walls fire stop fittings shall be used. Fire stop fittings shall be CFS and/or CFSI type as manufactured by:
- 1) O-Z/Gedney, Rosemont, IL.
  - 2) Or approved equal.
- f. For multiple conduit runs passing through interior or exterior and fire rated walls thru- wall barriers shall be used. Thru-wall barriers shall be TW series as manufactured by:
- 1) Crouse-Hinds, Syracuse, NY.
  - 2) Or approved equal.
- I. Conduit Tags:
1. Conduit tags shall be 19 gauge, 1-1/2-inch diameter round brass which shall be secured to the conduit with annealed brass wire.
  2. Conduit tags shall be clearly stamped with the conduit number in conformity with the conduit and cable schedule or as directed by the Engineer.
  3. Conduit tags shall be as manufactured by:
    - a. Seton Nameplate Corporation, Branford, CT.
    - b. Or approved equal.
- J. Conduit Markers:
1. Conduit identification markers shall be self-sticking color-coded tape. Identification tape shall be two inches wide and colored in accordance with the color banding specified under this Section.
  2. Conduit markers shall be as manufactured by:



## GENERAL SPECIFICATION 16131 - ELECTRIC CONDUIT SYSTEM

---

- a. Thomas and Betts, Memphis, TN.
- b. Or approved equal.

### 2.06 TERMINAL, JUNCTION AND PULL BOXES

- A. The Contractor shall provide terminal, junction and pull boxes as shown on the Contract Drawings and where otherwise required, or as directed by the Engineer.
- B. Boxes located indoor in dry, dusty areas shall be NEMA Type 12, constructed of welded and galvanized sheet steel. Boxes of dimensions 24 inches and less shall be 14 USS standard gauge metal. Boxes of dimensions greater than 24 shall be 12 USS standard gauge metal, except 10 USS standard gauge shall be used for boxes with any dimension of 36 inches or more.
- C. Boxes located in other areas shall conform to the following area classifications:
  1. For wet locations boxes shall be watertight NEMA Type 4. Boxes shall be constructed of galvanized cast iron and shall include gasketed, bolt on covers, with tapped holes in bosses or hubs for conduit entrance. Boxes shall be provided with cast mounting lugs for installation in concrete.
  2. For hazardous locations boxes shall be explosion proof NEMA Type 7. Boxes shall be constructed of cast iron and shall include threaded connections and ground joint surfaces.
  3. For corrosive locations boxes shall be corrosion resistant, NEMA Type 4X. Boxes shall be constructed of 316 stainless steel material with sealed seams.
- D. Pull and junction boxes shall be provided with covers held in place by brass screws. Terminal boxes shall be provided with terminal block supports and approved hinged covers fitted tightly against a gasket and secured by lug bolts and wing nuts. Hinges, lug bolts, wing nuts and other fittings shall be made of an approved, non-ferrous, non-corrodible metal. All boxes shall be provided with rabbeted gaskets or flange gaskets securely held in place.
- E. Tapping for threaded connections to outlet boxes, junction boxes, pull boxes and conduit fittings in non-explosion proof construction shall conform to the following:
  1. All threads shall be tapered.
  2. If threads for connection of conduit are tapped all the way through a hole in an enclosure, or if an equivalent construction is employed, there shall be not less than 3-1/2 threads in the metal and the construction of the enclosure shall be such that a suitable conduit bushing can be properly attached.

3. If threads for connections of conduit are not all the way through a hole in a box wall, conduit hub or the like, there shall be not less than five full threads in the metal and there shall be a smooth, well rounded inlet hole for the conductors, which shall afford protection to the conductors equivalent to that provided by a standard conduit bushing and which shall have an internal diameter approximately the same as that of the corresponding trade size of rigid conduit. The threaded hole shall be provided with a conduit end stop.
  4. Tapping for threaded connections for explosion proof construction shall conform to the requirements of the NYCEC for construction in Class I, Division 1, and hazardous locations.
- F. Cast iron or cast ferrous alloy outlet boxes, junction boxes, pull boxes, conduit fittings and conduit accessories such as box covers shall be rust-proofed by zinc coating applied by the "hot-dip" process or shall be given a rust protective coating applied by either of the following methods:
1. Method A:
    - a. Castings shall be given a mechanical and chemical cleaning.
    - b. Castings shall be given a phosphoric acid type dip.
    - c. Then a coating of zinc chromate primer shall be applied, and finally
    - d. A coating of baked enamel finish shall be applied over the outside and inside surfaces of the castings.
  2. Method B:
    - a. Castings shall be given a mechanical and chemical cleaning.
    - b. Then a coating of cadmium shall be deposited electrolytically.
    - c. Then a coating of zinc shall be applied by electroplating.
    - d. Then a vinyl resin base aluminum lacquer shall be applied.
- G. Stamped steel outlet boxes, junction boxes and box covers shall be rust-proofed by a zinc coating applied by an electro-galvanizing or sherardizing process. Fabricated sheet steel boxes shall be formed from galvanized sheet steel. Welded joints shall be touched up with aluminum lacquer and boxes and covers shall be given a shop priming coat of zinc chromate rust inhibiting paint.
- H. Terminal blocks shall be used within terminal boxes for termination of prepared conductors No. 10 AWG and smaller. Terminal blocks shall be in accordance with the following:

## GENERAL SPECIFICATION 16131 - ELECTRIC CONDUIT SYSTEM

---

1. Terminal blocks shall be high density, screw terminal type suitable for rail mounting with quantities sufficient for the conductors to be terminated plus 20 percent spare.
2. Terminal blocks shall be NEMA rated, 600 volt, 35 ampere suitable for 85 degrees C.
3. Terminal block components shall have stainless steel and tin plated copper alloy components, backed out captive screws and marking surface.
4. Terminal blocks shall be as manufactured by:
  - a. Allen-Bradley Company, Milwaukee, WI.
  - b. General Electric Company, Fairfield, CT.
  - c. Or approved equal.

### PART 3 EXECUTION

#### 3.01 GENERAL

- A. All conduits shall be installed in accordance with the requirements specified under this section and in conformity with the sizes stated in the Detailed Specifications or shown on the Contract Drawings. They shall be installed complete with all accessories, fittings and boxes, in an approved and workmanlike manner so as to provide proper raceways for electrical conductors.
- B. The Contractor's attention is called to the fact that all conduit runs indicated on the Contract Drawings are shown diagrammatically for the purpose of outlining the general method of routing the conduits to avoid interference. Where conduit runs are not shown, it shall be the responsibility of the Contractor to establish the runs required based upon the various systems shown on the Contract Drawings.
- C. Should any structural difficulties prevent the setting of cabinets, boxes, conduits, etc., at points shown on the plans, deviations therefrom as determined by the Engineer will be permitted and shall be made without additional cost.
- D. All exposed steel conduits, fittings, boxes, straps, racks and hangers shall be painted in conformity with General Specifications 09900 - Painting. PVC coated conduit systems shall not be painted. Paint shall match the gray color of the PVC coated conduits.
- E. Conduits shall be tagged using conduit tags. Conduit tags shall be installed where conduits terminate in equipment and enclosures.
- F. Exposed conduits shall be color banded using conduit markers. Markers shall also include operating voltage when over 600 volts. Conduit markers shall be

installed 360 degrees, double wrap around conduit exterior. Conduit markers shall be installed where conduits enter equipment, boxes, within each room, at wall penetrations and 50 feet on centers in each area. When exposed conduits are to be painted, markers shall be installed after the conduits are painted. Color banding shall be in accordance with the following:

1. 120/208 volt AC: Gray.
  2. 277/480 volt or 480 volt AC: Sand.
  3. 4160 volt AC: Silver.
  4. 13800 volt AC: Brown.
  5. Fire Detection and Alarm: Red.
  6. Telephone: Blue.
  7. Intercommunication: Yellow.
  8. Security System: Rust.
  9. Low Voltage Switching, Instrumentation and Controls System: Black.
- G. All enclosing cases, including condulets and conduit bodies, for fire, sprinkler, smoke detection, and associated systems alarm apparatus and equipment shall be painted or colored Fire Department "RED", in accordance with New York City Building Code, unless otherwise required by the local Authority Having Jurisdiction (AHJ).

### 3.02 INSTALLATION OF RACEWAYS

- A. The Contractor shall install all exposed raceways parallel or at right angles to walls and ceiling beams. Changes in directions shall be made with bends, elbows and pull boxes. All parallel runs shall be spaced uniformly throughout and secured in place with hangers and fasteners. Brace raceways to satisfy the specified seismic requirements in accordance with the restraint details.
- B. Conduits, where exposed, shall in all cases be substantially supported in an approved manner, but they shall not be fastened to or come in contact with any other pipes, ducts or other work of a similar nature. In all exposed work, approved channel or angle iron hangers, racks, one-hole straps or a combination thereof shall be provided to support the conduits. Where conduits are supported with one-hole straps, spacers shall be used to provide 1/4-inch minimum clearance between the conduits and walls or ceilings.
- C. Hanger rods for trapeze type hangers shall be not less than 5/8 inch diameter. Conduit supports shall be located at intervals not exceeding 8 feet. Conduits shall be securely fastened to each support with U-bolts, straps or clamps.

## GENERAL SPECIFICATION 16131 - ELECTRIC CONDUIT SYSTEM

---

- D. All concealed conduits shall be placed in walls, floors, ceilings or slabs at the proper time in accordance with the progress of the structural work. The Contractor shall cooperate in every respect in meeting schedules and shall not delay the structural work unnecessarily.
- E. Conduits embedded in concrete shall be blocked and braced in place by use of adequate conduit separators to prevent displacement during the pouring of concrete. The Contractor will be held responsible for proper position of conduits and shall rearrange any conduit that may be displaced while concrete is poured, without additional cost.
- F. Where conduit runs are to be concealed and the Contractor fails to place such conduit in sufficient time to be included in the structures and the structures are completed without such conduit, the Contractor shall install such runs either concealed or exposed as directed by the Engineer, with no extra payment for additional work or for more conduit than the original lengths.
- G. Embedded conduit shall be run in structural concrete in the center of slabs and walls and above waterstops. Conduit connections shall be made watertight. Contractor shall confirm that concrete thickness is sufficient for embedding the quantity of conduits intended. Unless specifically shown otherwise on the Contract Drawings or stated in the Detailed Specifications, embedded conduits shall be in accordance with the following criteria:
  - 1. Minimum concrete thickness shall be as follows:
    - a. For concrete 16 inches thick and less, the minimum concrete thickness shall be 11.5 inches plus the depth of the largest conduit assembly. The conduit assembly depth shall be from the top of the uppermost conduit to the bottom of the lowest conduit.
    - b. For concrete greater than 16 inches thick, the minimum concrete thickness shall be 13.5 inches plus the depth of the largest conduit assembly.
    - c. For concrete at foundation slabs, an additional inch shall be added to the minimum concrete thicknesses previously stated.
  - 2. Conduit spacing shall be as follows:
    - a. Conduits shall be separated three times outer diameter of larger conduit center to center.
    - b. For multiple conduit layer assemblies, conduits shall be separated vertically three times outer diameter of larger conduit center to center.
    - c. When conduits cross at a given point, the conduits may be in direct contact and the angle of cross shall be 45 degrees or

## GENERAL SPECIFICATION 16131 - ELECTRIC CONDUIT SYSTEM

---

- greater. Conduits may also cross within the vertical spacing of a multi-conduit layer assembly.
- d. When conduits cross a structural expansion joint, conduits shall be separated three times outer diameter of larger conduit fitting center to center.
- H. A run of conduit between outlet and outlet, between fitting and fitting or between outlet and fitting shall not contain more than the equivalent of three quarter bends, including those bends located immediately at the outlet or fitting.
  - I. Factory-made conduit bends or elbows shall be used wherever possible in making necessary changes in direction. Field bends shall be carefully made so as to prevent conduit damage or reduction in the internal areas. The radius shall not be less than six times the nominal diameters for the conduit with carefully matched bends on parallel runs so as to present a neat appearance.
  - J. All conduits, where cut, shall be carefully reamed to remove burrs. No running threads will be permitted. All screw joints shall be watertight. Conduits shall be fitted in an approved manner to all devices and boxes. The ends of all conduits shall be equipped with suitable approved conduit fittings. The ends of all empty conduits shall stub up six inches above the slab and shall be capped.
  - K. All conduits shall be carefully cleaned before and after installation and all inside surfaces shall be free from all imperfections likely to injure the cable. Conduits shall be cleaned in accordance with the following:
    - 1. After erection of complete conduit runs, conduits shall be snaked with a suitable swab to which shall be attached an approved tube cleaner equipped with an approved cylindrical mandrel of a diameter not less than 85 percent of the nominal diameter of the conduit.
    - 2. All conduits through which the mandrel will not pass shall be removed and replaced by the Contractor at his own expense.
    - 3. After snaking, the ends of the dead-ended conduits shall be protected with standard malleable iron caps to prevent the entrance of water or other foreign matter.
    - 4. Conduit ends shall be protected after cleaning with caps to prevent entrance of water, concrete, debris or other foreign substance.
  - L. As far as practicable, conduits shall be pitched to drain to outlet boxes or otherwise so installed as to avoid trapping moisture. Trapped conduits in concealed construction shall be provided with outlet boxes for drainage. Where necessary drainage in outlet boxes or where dips are unavoidable in exposed conduits, a drain fitting shall be installed at the low point.
  - M. Thruwall type seals and conduit sealing bushings shall be installed for all conduits passing through concrete slabs, floors, walls or block walls.

## GENERAL SPECIFICATION 16131 - ELECTRIC CONDUIT SYSTEM

---

- N. Conduit runs shall be installed so as to avoid flues, heat sources, and steam or hot water pipes. A minimum separation of 12 inches shall be maintained where conduit crosses or parallels hot water, steam pipes or heat sources.
  - O. Where conduit enter or leave equipment located within electrical and control rooms the conduit shall be sealed and packed with a suitable duct seal compound.
  - P. A 250 pound tested polyethylene pull tape shall be provided in all empty conduits, with a minimum 8 inch of slack, double backed into the conduit. Conduit shall be protected immediately after installation by installing flat non-corrosive metallic discs and steel bushings designed for this purpose at each end. Discs shall not be removed until it is necessary to clean the conduit.
  - Q. All conduit that is cut on the job shall be cut square and taper reamed to remove burrs before installation. Where steel conduit is cut and threaded on the site, it shall be coated before and after making connections.
  - R. Conduits embedded in concrete shall stub up 6 inches above the slab. A three inch high curb extending three inches from the outer surface of the conduit penetrating the floor shall be provided to prevent corrosion. Conduit stub-ups shall be terminated in couplings, slightly above the finished concrete curb.
- 3.03 CONDUIT CONNECTIONS TO EQUIPMENT
- A. At each motor, limit switch, solenoid valve, electrical control device or other electrically controlled or operated equipment, the Contractor shall install a complete conduit connection between the conduit system and the terminal box of the motor or the conduit connection point of the equipment.
  - B. Conduits installed in the conduit system shall be terminated in such locations as to permit direct connections to motors, devices or equipment.
  - C. Connections shall be made with rigid conduit if equipment is fixed and not subject to adjustment, mechanical movement or vibration. Rigid connections shall be provided with union fittings to permit removal of equipment without cutting, breaking or burning conduit.
  - D. Motors, transformers and equipment subject to adjustment, mechanical movement or vibration shall be connected with flexible metallic conduit.
  - E. Devices such as solenoid valves, small limit switches, etc., shall be connected with flexible metallic conduit arranged to prevent strain and distortion.
  - F. Flexible conduit connections shall be watertight unless the area of installation requires explosion-proof construction.
- 3.04 INSTALLATION OF BOXES AND FITTINGS
- A. All concealed outlet boxes shall be set in such a manner that they will be plumb and flush with the finished surface.

## GENERAL SPECIFICATION 16131 - ELECTRIC CONDUIT SYSTEM

---

- B. Boxes shall be installed rigidly and securely to the structure. Independent supports shall be provided where no walls or other structural surface exists.
- C. Expansion and expansion/deflection fittings shall be installed where conduits cross structural expansion joints and at locations shown on the Contract Drawings. Fittings shall be installed on each conduit and incorporated into the expansion joints of structures, at right angles to the joint, to insure their proper functioning and preservation.
- D. Expansion fittings shall be installed on exposed conduit runs exceeding 200 feet. Unless specifically shown otherwise on the Contract Drawings or stated in the Detailed Specifications, when crossing structural expansion joints larger than one inch, an expansion fitting shall also be installed together with an expansion/deflection fitting. The fittings shall be installed on each conduit run in accordance with manufacture's recommendations to provide the additional movement necessary.
- E. All conduit connections in wet and corrosive locations shall be made up watertight and shall terminate at enclosures with an approved conduit hubs.
- F. All conduit connections in dry and dusty locations shall terminate at enclosures with bushings and lock nuts. Terminations shall include one bushing and two lock nuts at each location. Lock nuts shall be installed one inside and one lock nut outside the enclosure. All conduit shall be bonded to the safety ground.
- G. At pull and junction boxes having any box dimension in excess of 18 inches, jumper type grounding bushings shall be installed on conduit ends and jumper wires shall be installed to bond all conduits and to bond conduits to boxes.
- H. All insulated grounding bushings shall be bonded together and to the structure of the enclosure by a continuous, copper bonding wire.
- I. Removable, flame-retardant, insulating cable supports shall be provided in all boxes with any dimension exceeding 3 feet.
- J. Scratched PVC coated boxes and fittings damaged as a result of installation work shall be touched up by field applying PVC coatings. All touch up work shall be in strict conformance with manufacturer's recommendations.

### 3.05 INSTALLATION WITHIN HAZARDOUS AREAS

- A. Explosion-proof boxes and fittings shall be of a type approved by the Engineer. Boxes and fittings shall be of cast iron with finish as specified hereinbefore or of an aluminum alloy specially developed for use in hazardous areas.
- B. Explosion-proof boxes shall be suitable for the installation of explosion-proof switches, receptacles, lighting fixtures or other devices as indicated. All conduit connections to such boxes shall be made with threaded fittings. Bushings and locknut connections shall not be used.



## GENERAL SPECIFICATION 16131 - ELECTRIC CONDUIT SYSTEM

---

- C. Conduits terminating at explosion-proof boxes, enclosing circuit opening equipment, shall be sealed at the entrance to the box with an approved compound-filled sealing fitting to prevent passage of explosive or combustible gases through the conduit. Where construction prevents the use of sealing fittings, the ends of the conduits shall be properly sealed with sealing compound.
- D. Sealing fittings shall be installed to seal each conduit leading from or entering into hazardous locations. Exposed conduits passing through hazardous locations shall be sealed at point of exit and entrance.
- E. The installation of explosion-proof boxes, fittings and all conduits in connection therewith shall conform to the requirements of the NYCEC for Class I, Division 1 Group D hazardous location.

### 3.06 FIELD TESTS

- A. After installation, the electric conduit system shall be field tested. The field tests shall be witnessed by the Engineer and certified by the Contractor. The Contractor shall provide testing consisting of the following:
  - 1. Each conduit shall be tested by pulling through a cylindrical mandrel as specified under this Section. Maintain a record of all conduits testing clear.
  - 2. Conduit systems shall be ground tested in the presence of the Engineer, who will inspect all enclosures, pull and junction boxes for bonding to the safety green conductor pulled with the nominal 120 volt and higher power and control circuits, and for bonding of the conduit grounding bushing to this safety ground.
  - 3. The separation of above safety grounding system from the instrumentation signal grounding shall be verified.
- B. The Contractor shall provide a Field Test Report. The Report shall identify the testing performed and the results obtained.

END OF SECTION

NO TEXT ON THIS PAGE

**GENERAL SPECIFICATION 16133 - UNDERGROUND DUCTS - DUCTS IN  
CONCRETE**

---

**SECTION 16133  
Underground Ducts - Ducts in Concrete**

**PART 1 GENERAL**

**1.01 SECTION INCLUDES**

- A. Requirements for providing underground ducts. Underground ducts shall be provided in accordance with the requirements specified under this section, the Detailed Specifications and the Contract Drawings.
- B. Underground ducts shall be concrete encased. The Contractor shall provide reinforced concrete encasement for the duct system.
- C. The Contractor shall perform all excavations and backfilling, as required, unless specifically shown otherwise on the Contract Drawings or stated in the Detailed Specifications.
- D. The following index of this Section is included for convenience:

<u>Article</u>	<u>Title</u>	<u>Page</u>
		16133-
PART 1	GENERAL .....	1
1.01	SECTION INCLUDES .....	1
1.02	PAYMENT .....	1
1.03	RELATED SECTIONS .....	2
1.04	REFERENCES .....	2
1.05	SUBMITTALS .....	2
1.06	DELIVERY, STORAGE AND HANDLING .....	3
PART 2	PRODUCTS.....	3
2.01	RIGID STEEL CONDUIT .....	3
2.02	NON-METALLIC CONDUIT AND FITTINGS.....	3
2.03	CONDUIT SPACERS .....	3
2.04	WARNING RIBBON.....	4
2.05	DUCT SEAL.....	4
2.06	REINFORCED CONCRETE .....	4
2.07	EXPANSION AND DEFLECTION FITTINGS.....	4
2.08	CONDUIT BUSHINGS .....	4
PART 3	EXECUTION.....	4
3.01	INSTALLATION .....	4

**1.02 PAYMENT**

- A. Payment for electric underground ducts shall be made as provided for in the Detailed Specifications.

## GENERAL SPECIFICATION 16133 - UNDERGROUND DUCTS - DUCTS IN CONCRETE

---

### 1.03 RELATED SECTIONS

- A. General Specification 01411 - Envision Requirements
- B. General Specification 02316 - Excavation
- C. General Specification 02317 - Backfilling
- D. General Specification 03300 - Cast-in-Place Concrete
- E. General Specification 05120 - Structural Steel
- F. General Specification 16061 - Grounding
- G. General Specification 16131 - Electric Conduit System

### 1.04 REFERENCES

- A. Underground ducts shall comply with the latest applicable provisions and recommendations of the following:
  - 1. NYCEC - New York City Electrical Code.
  - 2. NESC - National Electrical Safety Code.
  - 3. UL 651 - UL Standard for Safety Schedule 40, 80, Type EB and A Rigid PVC Conduit and Fittings.
  - 4. NEMA TC2 - Electrical Polyvinyl Chloride (PVC) Tubing and Conduit.
  - 5. UL 2420 - UL Standard for Safety Belowground Reinforced Thermosetting Resin conduit (RTRC) and Fittings.

### 1.05 SUBMITTALS

- A. Contractor shall submit Shop Drawings and material specifications for the approval of the Engineer. Submittals shall include, but not be limited, to:
  - 1. A list of proposed manufacturers with the products they produce proposed for the contract.
  - 2. Manufacturer's Literature with manufacturer's name, designation and catalog number for all products proposed for the underground duct system.
  - 3. Scaled Shop Drawings showing the routing of the duct banks and the location of manholes, handholes and the principal outline of buildings and structures. Reference duct banks dimensionally from fixed objects or structures. Include profiles of duct banks showing crossings with piping and other underground systems.

**GENERAL SPECIFICATION 16133 - UNDERGROUND DUCTS - DUCTS IN  
CONCRETE**

---

- B. The Contractor shall report information pertaining to the sustainable procurement, regional sourcing, and recycled content of new materials to be procured during the Work, in accordance with General Requirements 01411 – Envision Requirements.

1.06 DELIVERY, STORAGE AND HANDLING

- A. Underground ducts shall be delivered, stored and handled in accordance with the Detailed Specifications and the manufacturer’s instructions.

PART 2 PRODUCTS

2.01 RIGID STEEL CONDUIT

- A. Rigid Steel conduit without a PVC coating shall be used for all ducts. Rigid Steel Conduit shall be in accordance with the requirements of General Specification 16131 - Electric Conduit System.

2.02 NON-METALLIC CONDUIT AND FITTINGS

- A. Non-metallic conduit for ducts where shown on the Contract Drawings shall be PVC plastic or fiberglass-reinforced epoxy.

- 1. PVC plastic conduit shall be Schedule 40, NEMA type EPC-40 rated 90 degrees C, conforming to UL No. 651.
- 2. Reinforced thermosetting resin conduit and fittings shall conform to UL No. 2420. Both conduit and fittings shall consist of 68 percent glass content encapsulated in an epoxy matrix.

- B. All non-metallic fittings, elbows, bodies, terminations, expansions and fasteners shall be the same material and manufacturer as the conduit.

- C. PVC conduit shall be as manufactured by:

- 1. Allied Tube & Conduit, Harvey, IL.
- 2. Heitage Plastics, Harvey, IL.
- 3. Or approved equal.

- D. Fiberglass-reinforced epoxy conduit shall be as manufactured by:

- 1. FRE Composites, Boston, MA.
- 2. Champion Fiberglass, Spring, TX.
- 3. Or approved equal.

2.03 CONDUIT SPACERS

- A. Factory fabricated conduit spacers shall be nonmetallic, vertical and horizontal interlocking type to maintain spacing between conduits. Spacers shall be suitable for all types of conduit in multiple sizes.

**GENERAL SPECIFICATION 16133 - UNDERGROUND DUCTS - DUCTS IN  
CONCRETE**

---

2.04 WARNING RIBBON

- A. Warning ribbon shall be a three inch wide, four mil polyethylene or polyvinyl chloride detectable tape. The tape shall be permanently imprinted in red color, "CAUTION BURIED ELECTRIC LINE BELOW." Warning tape shall be by:
  - 1. Seton, Branford, CT.
  - 2. Ideal Industries, Sycamore, IL.
  - 3. Or approved equal.

2.05 DUCT SEAL

- A. Duct seal for conduits shall be in accordance with the requirements of General Specification 16131 - Electric Conduit System.

2.06 REINFORCED CONCRETE

- A. Concrete for envelope shall be in accordance with the requirements of General Specification 03300 - Cast-in-Place Concrete. Steel reinforcement shall be in accordance with the requirements of General Specification 05120 - Structural Steel.

2.07 EXPANSION AND DEFLECTION FITTINGS

- A. Where specifically shown on the Contract Drawings, expansion and deflection fittings shall be provided at the structural joints of the underground duct system.
- B. Expansion and deflection fittings shall be in accordance with General Specification 16131 - Electric Conduit System.

2.08 CONDUIT BUSHINGS

- A. Conduit bushings shall be provided for the termination of rigid steel conduits at each manhole.
- B. Conduit bushings shall be in accordance with General Specification 16131 - Electric Conduit System.

PART 3 EXECUTION

3.01 INSTALLATION

- A. The duct system shall be installed to avoid interferences with structures, piping and other underground systems. Conduit duct banks shall be sized, arranged and installed in a reinforced concrete envelope as shown on the Contract Drawings.
- B. Trenches for duct banks shall be in accordance with the requirements of General Specification 02316 - Excavation. Duct bank trenches shall have the bottom tamped firm and even, and suitably braced side forms shall be employed in forming the envelope.

**GENERAL SPECIFICATION 16133 - UNDERGROUND DUCTS - DUCTS IN  
CONCRETE**

---

- C. Duct banks shall follow straight lines as far as possible. Where deviation from a straight line becomes necessary, offsets shall be made using 5 degree angle coupling or make bend with sweeps. The sweep radius shall be 48 inch for 90 and 45 degree bends and 36 inch for 30 degree bends. Where directed by the Engineer, bends shall be made up with standard factory bends or other approved curved sections.
- D. Duct bank installations and penetrations through foundation walls shall be made watertight.
- E. Duct banks shall be assembled using non-magnetic saddles, spacers and separators. Separators shall be positioned to provide 3-inch minimum concrete separation between the outer surfaces of the ducts.
- F. Concrete covering shall be provided on both sides, top and bottom of the concrete envelopes around conduits. Concrete covering shall be in accordance with the detail shown on the Contract Drawings. Top of concrete encasement shall not be less than thirty inches below finish grade. Add red dye to concrete used for envelopes or trowel a coloring on the concrete for easy identification during subsequent excavation.
- G. Before pouring concrete, written approval shall be obtained from the inspecting engineer.
- H. Ducts shall be firmly fixed in place during pouring of concrete. Concrete shall be carefully spaded and vibrated to insure filling of all spaces between ducts.
- I. A transition shall be made from non-metallic to rigid steel conduit where duct banks enter structures or turn upward for continuation above grade. Rigid steel ducts shall be terminated using insulated grounding bushings. Ducts inside buildings shall be continued using rigid steel or PVC coated rigid steel conduits as required for the area.
- J. Ducts entering manholes and hand holes shall be terminated using suitable end bells. Rigid steel ducts shall be terminated using insulated grounding bushings.
- K. Backfilling for duct banks shall be in accordance with the requirements of General Specification 02317 - Backfilling. Backfilling shall be permitted when directed by the engineer to proceed. Backfilling shall not be with material containing large rock, paving materials, cinders, large or sharply angular substances, corrosive material or other materials which can damage or contribute to corrosion of ducts or cables or prevent adequate compaction of fill.
- L. Duct runs shall be sloped for drainage toward manholes and away from buildings with a slope of approximately 3 inches per 100 feet.
- M. A ground cable shall be installed in each duct bank envelope. Cable shall be in accordance with the requirements of General Specification 16061 - Grounding. The ground shall be made electrically continuous throughout the entire duct

**GENERAL SPECIFICATION 16133 - UNDERGROUND DUCTS - DUCTS IN  
CONCRETE**

---

- bank system. Ground cable shall be connected to the building, station ground grid, equipment ground buses and to each conduit grounding bushing of the underground duct system. The ground cable shall be terminated at the last manhole or handhole for outlying structures.
- N. After installation each conduit in each duct bank shall be cleaned and cleared of obstructions and foreign matter by rodding and by the passage of cleaning brushes or cutting mandrels. After cleaning, the clearance of each conduit shall be checked by passing a 12 inch long mandrel, of diameter 1/2 inch less than the nominal duct diameter, through the entire length of duct run. Ducts which do not permit passage of the mandrel shall be cleared, cut out and replaced or sealed and replaced by additional construction. The duct bank conduit cleaning shall be included in the electric conduit system field test report specified in General Specification 16131 - Electric Conduit System.
- O. A warning ribbon shall be installed approximately 12 inches below finished grade over all underground duct banks carrying cables of 480 volts and higher.
- P. All ducts entering buildings and structures shall be sealed. All empty spare ducts shall be sealed and plugged.
- Q. An expansion and deflection fitting shall be installed on each conduit at each of the structural expansion joints when shown on the Contract Drawings. Joints shall be located as defined by the criteria noted on the Contract Drawings.

END OF SECTION



**SECTION 16211  
Electrical Service Entrance**

**PART 1 GENERAL**

**1.01 SECTION INCLUDES**

- A. Requirements for providing electrical service entrance low-voltage equipment. Electrical service entrance equipment shall be provided in accordance with the requirements specified under this Section, the Detailed Specifications and the Contract Drawings.
- B. The electrical service entrance equipment required under this section shall be the low-voltage type suitable for delivering electric energy from the Utility to the electric power distribution system of the facility served.
- C. The electrical service entrance work under this section also includes coordination with the Utility and installation of the Utility metering equipment.
- D. The following index of this Section is included for convenience:

<u>Article</u>	<u>Title</u>	<u>Page</u>
		16211-
PART 1	GENERAL .....	1
1.01	SECTION INCLUDES .....	1
1.02	PAYMENT .....	1
1.03	RELATED SECTIONS .....	2
1.04	REFERENCES .....	2
1.05	SUBMITTALS .....	2
1.06	QUALITY ASSURANCE .....	3
1.07	SEISMIC REQUIREMENTS:.....	4
1.08	DELIVERY, STORAGE AND HANDLING .....	4
PART 2	PRODUCTS.....	4
2.01	MANUFACTURERS .....	4
2.02	SERVICE ENTRANCE EQUIPMENT .....	5
2.03	PAINTING.....	6
2.04	SHOP TESTS .....	6
PART 3	EXECUTION.....	7
3.01	INSTALLATION .....	7
3.02	FIELD TESTS .....	7
3.03	MANUFACTURER’S FIELD SERVICES.....	8
3.04	ACCEPTANCE TESTING.....	8

**1.02 PAYMENT**

- A. Payment for electrical service entrance equipment shall be made as provided for in the Detailed Specifications.

## GENERAL SPECIFICATION 16211 - ELECTRICAL SERVICE ENTRANCE

### 1.03 RELATED SECTIONS

- A. General Specification 16055 - Shock Hazard and Arc Flash Studies.
- B. General Specification 16076 - Labeling and Identification.
- C. General Specification 16292 - Power Distribution System Coordination.
- D. General Specification 16430 - Low-Voltage Switchgear
- E. General Specification 16442 - Electrical Control Equipment - Low-voltage A.C. Motors and Devices.

### 1.04 REFERENCES

#### A. Definitions

1. Low-voltage as used in this Section and the Specifications shall mean all equipment, conductors, insulation systems and accessories intended for operation within the 600 Volt Class.
2. All references to the Electric Utility or Utility shall mean the Local Electric Utility having jurisdiction as defined in the Detailed Specifications

#### B. Reference Standards

Electrical service entrance equipment shall comply with the latest applicable provisions and recommendations of the following:

1. Electric Utility.
2. NYCEC - New York City Electrical Code.
3. UL Standard No. 891 - Switchboards.
4. NETA ATS - Acceptance Testing Specifications
5. NEMA PB-2 - Dead Front Distribution Switchboards.

### 1.05 SUBMITTALS

#### A. Contractor shall submit Shop Drawings and material specifications for the approval of the Engineer. Submittals shall include, but not be limited, to:

1. Manufacturer's technical information which shall include:
  - a. Dimensional information.
  - b. Three-line diagrams.
  - c. Technical specifications.
  - d. Catalog cuts.
  - e. Construction details of enclosures.

## GENERAL SPECIFICATION 16211 - ELECTRICAL SERVICE ENTRANCE

2. Description of shop and field testing methods, procedures and apparatus with calibration dates shall be submitted. Testing methods and procedures shall be submitted at least 45 days in advance prior of actual testing.
3. Qualifications of proposed testing firm to perform acceptance testing shall be submitted. Submit firm experience records at least 45 days in advance to actual testing, five recent references with phone numbers shall be submitted.
4. Service entrance equipment anchorage details with design calculations signed by Professional Engineer, licensed in the State of New York.

B. Certificates of Compliance:

1. Seismic qualification certification from the manufacturer including mounting recommendations.

C. Reports:

1. Shop test and field test reports shall be submitted.
2. Manufacturer's site visit and acceptance testing reports shall be submitted.

D. Operations and Maintenance Manuals shall be submitted in accordance with the Detailed Specifications.

### 1.06 QUALITY ASSURANCE

A. General:

1. Contractor shall make all necessary arrangements with the Utility to obtain the service entrance supply. It shall be the responsibility of the Contractor to notify and coordinate in advance with the Utility to obtain the service required.
2. All work regarding the service entrance supply and equipment shall conform to the requirements of the Utility.
3. The service entrance equipment shall be designed and built in accordance with the latest applicable editions of NEMA, UL and the Utility.
4. The service entrance equipment shall be suitable as service entrance equipment and UL labeled as such.
5. The service entrance equipment manufacturer shall use a shop test facility that has recently calibrated testing apparatus and qualified, experienced technicians, for all factory tests. Calibration of testing apparatus shall be within one year.

6. All test equipment and instrument calibration shall be in accordance with the latest edition of the accuracy standard of the U.S. National Institute of Standards and Technology and the NETA acceptance testing specification.

1.07 SEISMIC REQUIREMENTS SEISMIC REQUIREMENTS

1. The service entrance equipment shall be designed, constructed and installed suitable for earthquake regulations in accordance with the seismic requirements of the City of New York Building Code and the Uniform Building Code for zone 2A application.

B. Field Tests:

1. The service entrance equipment shall be field tested. Field testing shall be performed in accordance with the requirements specified under this Section.
2. The services of the service entrance equipment manufacturer shall be retained for field service. Field service shall be in accordance with the requirements specified under this Section.
3. Retain the service of an independent testing firm who shall perform field acceptance testing of the service entrance equipment. The testing firm shall have experience in the inspection and testing of service entrance equipment and shall be a member company of NETA. Acceptance testing shall be in accordance with the requirements specified under this Section.

1.08 DELIVERY, STORAGE AND HANDLING

- A. Service entrance equipment shall be delivered, stored and handled in accordance with the Detailed Specifications and the manufacturer's recommendations.

PART 2 PRODUCTS

2.01 MANUFACTURERS

- A. Service entrance equipment shall be manufactured by:
  1. Eaton, Fayetteville, NC.
  2. General Electric Company, Fairfield, CT.
  3. Or approved equal.

2.02 SERVICE ENTRANCE EQUIPMENT

A. General:

1. The service entrance equipment shall be dead front switchboard type construction, unless specifically shown or stated to be made a part of the low-voltage switchgear.
2. The service entrance equipment shall consist of a Utility metering compartment and a main service disconnect.
3. The service entrance equipment shall be arranged with the number of sections and compartments as shown on the Contract Drawings. The metering compartment shall be constructed for hot metering sequence.
4. The service entrance equipment shall be equipped with a bonding jumper to bond the enclosure and ground bus to the neutral, a neutral disconnect link to disconnect the neutral and a barrier to isolate service bus bars and terminals.
5. Where shown on the Contract Drawings or stated in the Detailed Specifications, the metering compartment and main service disconnect shall be made a part of the low-voltage switchgear.
6. Service entrance equipment when part of the low-voltage switchgear shall be in accordance with the requirements of General Specification 16430 - Low-Voltage Switchgear.

B. Ratings:

1. The service entrance equipment shall be 600 volt class suitable for operation on a three phase 60 hertz system.
2. The system operating voltage, number of wires, bus ampacity and short circuit withstand capability shall be as shown on the Contract Drawings.
3. The short circuit interrupting rating of the main service disconnect shall be as shown on the Contract Drawings.

C. Bus Bars:

1. The service entrance equipment bus bars shall be tin-plated copper, supported by high impact, non-tracking insulating material. The bus joints shall be secured with belleville type washers and shall be braced for the mechanical forces exerted during short circuit conditions.
2. Bus bar sizes shall be based upon a maximum temperature rise of 65 degrees C over a 40 degrees C ambient in accordance with UL and NEMA.
3. Bus bar sizes where applicable shall be based upon the requirements of the NYCEC.

## GENERAL SPECIFICATION 16211 - ELECTRICAL SERVICE ENTRANCE

4. A ground bus shall be secured to each vertical section and shall extend the entire length of the service entrance equipment. The ground bus shall have a current capacity equal to 1/2 the capacity of the main power bus.

### D. Structure:

1. The service entrance equipment structure shall be completely self-supporting and shall include the required number of vertical sections bolted together to form one metal enclosed enclosure.
2. The service entrance equipment enclosure for indoor dry locations shall be rated NEMA 12 and shall be rated for other environments as defined in the Detailed Specifications.
3. The enclosure structure frame shall be die-formed, 12 gauge steel bolted together and reinforced.
4. The service entrance equipment shall have identifying nameplates in accordance with the requirements of General Specification 16076 - Labeling and Identification.

### E. Main Service Disconnect:

1. The main service disconnect shall be circuit breaker molded case type unless shown on the Contract Drawings or stated in the Detailed Specifications to be a low-voltage power circuit breaker.
2. Molded case circuit breakers shall be in accordance with the requirements of General Specification 16442 - Electric Control Equipment - Low-Voltage A.C. Motors and Devices.
3. Low-voltage power circuit breakers shall be in accordance with the requirements of General Specification 16430 - Low-voltage Switchgear.

## 2.03 PAINTING

- A. All metal surfaces of the service entrance equipment enclosure shall be thoroughly cleaned and given one coat of zinc chromate primer. All interior surfaces shall then be given one shop finishing coat of a nitro-cellulose enamel lacquer.
- B. All exterior surfaces shall be given three coats of the same lacquer. The color of finishing coats shall be light gray ANSI No. 61.

## 2.04 SHOP TESTS

### A. Certified Shop Tests:

1. Shop testing shall be performed on the service entrance equipment at the manufacturer's plant prior to shipment. Shop test shall be in accordance with the latest revisions of ANSI and shall demonstrate that the equipment tested conforms to the requirements specified.

## GENERAL SPECIFICATION 16211 - ELECTRICAL SERVICE ENTRANCE

2. The Contractor shall provide a shop test report. The report shall identify the tests performed and the results obtained.
3. Service entrance equipment shop tests shall include the following:
  - a. Physical inspection shall be performed including torque tests of bus bolts.
  - b. Mechanical operations shall be performed to insure proper functioning of operating mechanisms and interchangeability.
  - c. Continuity test shall be performed on power and control wires.
  - d. Primary hi-potential tests shall be performed. Primary current carrying parts shall be tested between phases, phase to ground, and line to load. The applied voltage shall be twice rated voltage plus 1000 for 1 minute.
  - e. Hi-Potential tests on secondary wiring shall be performed. Secondary wiring shall be tested for 1500 volts to ground for 1 minute.
  - f. Power cables and buses shall be tested, for insulation breakdown resistance and circuit isolation. Test voltage frequency shall not be less than the frequency of the rated voltage of the equipment tested.

### PART 3 EXECUTION

#### 3.01 INSTALLATION

- A. Equipment shall be installed in accordance with manufacturer's instructions and recommendations.
- B. Equipment shall be installed so that sufficient access and working space is provided for ready and safe operation and maintenance.
- C. Equipment shall be installed on concrete pads at locations shown on the Contract Drawings. Steel channels shall be provided for support of equipment. Equipment shall be securely mounted to surface with anchor bolts. Anchor service entrance equipment to satisfy the specified seismic requirements in accordance with the anchorage details.
- D. Install nameplates for identification of equipment.

#### 3.02 FIELD TESTS

- A. After installation, service entrance equipment shall be field tested for operation and conformance. The Contractor shall perform field testing in accordance with the Detailed Specifications. The field tests shall be witnessed by the Engineer and certified by the Contractor.

## GENERAL SPECIFICATION 16211 - ELECTRICAL SERVICE ENTRANCE

- B. Service entrance equipment testing shall be performed by the manufacturer's representative, prior to energizing equipment. The testing shall be in accordance with the recommendations of the manufacturer's representative. Equipment shall not be energized without the permission of the Engineer.

### 3.03 MANUFACTURER'S FIELD SERVICES

- A. A qualified manufacturer's representative shall assist in the installation of the service entrance equipment, check the equipment installation before it is placed into operation, assist in the performance of field tests, observe and assist initial operations and train the plant operations and maintenance staff in the care, operation and maintenance of the service entrance equipment.
- B. The Contractor shall provide equipment start-up services and training in accordance with the Detailed Specifications.
- C. The Contractor shall provide a field report from the manufacturer's representative for each visit to the site. The report shall include complete information on time, schedule, tasks performed, persons contacted, problems corrected, tests results, training, instruction and all other pertinent information.
- D. The service representative shall sign in with the Engineer on each day they are at the site.

### 3.04 ACCEPTANCE TESTING

- A. The Contractor shall provide acceptance testing of the service entrance equipment. All acceptance testing shall be performed by the testing firm, after the completion of the Field Tests specified under this Section. The acceptance testing shall be witnessed by the Engineer and certified by the Contractor.
- B. Acceptance testing inspection shall be performed on each service entrance equipment. Inspection shall include the following:
  - 1. Physical, electrical and mechanical condition shall be inspected.
  - 2. Proper anchorage, required area clearances, physical damage and proper alignment shall be checked.
  - 3. All electrical connections shall be inspected for high resistance.
  - 4. Insulators shall be inspected for evidence of damage or contamination.
  - 5. Equipment shall be cleaned and lubricated as required.
- C. Acceptance electrical testing shall be performed on each service entrance equipment. Testing shall include the following:
  - 1. Ground-resistance tests shall be performed.
  - 2. Insulation-resistance tests shall be performed on each bus section and circuit breaker, phase-to-phase and phase-to-ground.



## **GENERAL SPECIFICATION 16211 - ELECTRICAL SERVICE ENTRANCE**

3. An over potential test shall be performed on each bus section, each phase-to-ground.
  4. Contact-resistance test shall be performed.
  5. Circuit breaker trip characteristics shall be determined by primary current injection
  6. Protective devices shall be set based upon approved Power Distribution Coordination and Arc Flash Studies.
- D. All tests and values shall be in accordance with the manufacturer's recommendations and NETA, ATS Acceptance Testing Specification.
- E. The Contractor shall provide an acceptance testing report. The report shall be in accordance with NETA, ATS Acceptance Testing Specification.

END OF SECTION

**GENERAL SPECIFICATION 16211 - ELECTRICAL SERVICE ENTRANCE**

NO TEXT ON THIS PAGE

**SECTION 16221  
Electric Motors**

**PART 1 GENERAL**

**1.01 SECTION INCLUDES**

- A. Requirements for providing electric motors. The electric motors shall be provided in accordance with the requirements specified under this section, the General and Detailed Specifications and the Contract Drawings.
- B. The following index of this Section is presented for convenience:

<u>Article</u>	<u>Title</u>	<u>Page</u>
		16221-
PART 1	GENERAL .....	1
1.01	SECTION INCLUDES .....	1
1.02	PAYMENT .....	1
1.03	RELATED SECTION .....	2
1.04	REFERENCES .....	2
1.05	SYSTEM DESCRIPTION .....	2
1.06	DESIGN REQUIREMENTS .....	3
1.07	SUBMITTALS .....	4
1.08	QUALITY ASSURANCE .....	5
1.09	DELIVERY, STORAGE AND HANDLING .....	6
1.10	SPARE PARTS .....	7
PART 2	PRODUCTS .....	8
2.01	SINGLE PHASE AC MOTORS .....	8
2.02	THREE PHASE AC MOTORS .....	8
2.03	DC MOTORS .....	13
2.04	ACCESSORIES .....	13
2.05	PAINTING .....	15
2.06	SHOP TESTS .....	15
PART 3	EXECUTION .....	17
3.01	INSTALLATION .....	17
3.02	FIELD TESTS .....	17
3.03	MANUFACTURER'S FIELD SERVICES .....	18
3.04	ACCEPTANCE TESTING .....	18

**1.02 PAYMENT**

- A. Payment for electric motors shall be made as provided for in the Detailed Specifications. Unless otherwise specified in the Detailed Specifications, no separate payment shall be made for motors furnished under the various contract items. The costs of motors shall be included in the price bid for the driven equipment.

## GENERAL SPECIFICATION 16221 - ELECTRIC MOTORS

---

### 1.03 RELATED SECTION

- A. General Specification 15076 - Piping and Equipment Identification

### 1.04 REFERENCES

- A. Electric motors shall comply with the latest applicable provisions and recommendations of the following:

1. EISA 2007 - Energy Independence and Security Act of 2007
2. EAct 1992 - Energy Policy and Conservation Act of 1992
3. NYCEC - New York City Electrical Code.
4. NEMA Standard -MG1 - Motors and Generators.
5. NEMA Standard – MG 10 - Energy Management Guide for Selection and Use of Fixed Frequency Medium AC Squirrel-Cage Polyphase Induction Motors.
6. UL Standard 674 - Electric Motors and Generators for use in Hazardous Locations.
7. UL Standard 1004 - Electric Motors.
8. AFBMA Standard 9 - Load Ratings and Fatigue Life for Ball Bearings.
9. AFBMA Standard 11 - Load Ratings and Fatigue Life for Roller Bearings.
10. API Standard 541 - Form-Wound Squirrel-Cage Induction Motors 375 kW (500 Hp) and Larger
11. IEEE Standard 841 - Premium-Efficiency, Severe Duty Totally Enclosed Fan- Cooled Squirrel-Cage Induction Motors.
12. NETA ATS - Acceptance Testing Specifications.

### 1.05 SYSTEM DESCRIPTION

- A. Specific motor data such as HP, RPM, enclosure type, shall be as stated in the Detailed Specifications. The specific motor data is specified under the Detailed Specification for the mechanical equipment with which the motor is supplied. The motor types specified under this section shall include:
1. Single Phase, alternating current, fractional horsepower induction motors.

## GENERAL SPECIFICATION 16221 - ELECTRIC MOTORS

---

2. Three Phase, alternating current, NEMA frame, squirrel cage, induction motors.
3. Three Phase, alternating current, above NEMA frame, squirrel cage, induction motors.
4. Three Phase, alternating current, submersible, squirrel cage, induction motors.
5. Three Phase, alternating current, wound-rotor, squirrel cage, induction motors.
6. Direct current, small motors.

### 1.06 DESIGN REQUIREMENTS

- A. Motors shall be designed, built, and tested in accordance with the latest applicable editions of ANSI/IEEE, NEMA, UL and NYCEC. The classifications, ratings, performance and testing of all motors shall be in accordance with the latest edition of NEMA Publication No. MG1.
- B. Motors shall be of sufficient capacity to operate the driven equipment under all conditions of operation without loading the motors beyond their rated nameplates current and power under all operating conditions imposed by the driven equipment.
- C. The rating of the motors offered shall in no case be less than the horsepower shown on the Contract Drawings or stated in the Detailed Specifications. Both the rating and the characteristics of the motor shall be suitable for the successful operation of the driven equipment, under load conditions, within nameplates values of service factor and ambient temperatures.
- D. Unless otherwise stated in the Detailed Specifications, motors shall be of three phase construction for ratings above 1/3 horsepower and single phase construction for 1/3 horsepower or less.
- E. All motors operating at 460 volts and below shall be of a type approved for starting characteristics and ruggedness as may be required under the actual conditions of operation. Unless otherwise stated in the Detailed Specifications, motors shall be designed for full voltage starting. When the motor is reduced voltage started, the motor shall develop ample torque for acceleration under the conditions imposed by the reduced voltage starting method.
- F. Multi-speed motors shall have a separate winding for each speed unless otherwise stated in the Detailed Specifications.
- G. Portable devices shall have totally enclosed motors and approved cord with provisions for grounding. They shall be suitable for the available power supply.
- H. All motors shall be continuous time rated suitable for operation in a 40 degrees C ambient unless stated otherwise in the Detailed Specification.

## GENERAL SPECIFICATION 16221 - ELECTRIC MOTORS

---

- I. Unless otherwise specified in the General and Detailed Specifications motors shall be premium efficiency type and shall have nominal efficiencies in accordance with NEMA MG1. Motors with horsepower or RPM's not listed by NEMA shall conform to comparable standards of construction and materials as those for listed NEMA motors.
- J. Motors shall comply with the EPAct 1992 and EISA 2007.
- K. Variable-speed motors shall comply with NEMA MG1.
- L. Variable-speed motors operated from variable frequency drives shall comply with NEMA MG1.

### 1.07 SUBMITTALS

- A. Contractor shall submit Shop Drawings and material specifications for the approval of the Engineer. Submittals shall include, but not be limited, to:
  - 1. A list of proposed manufacturers with the products they produce proposed for the contract.
  - 2. For fractional horsepower motors, data sheets showing nameplate data shall be submitted.
  - 3. For motors rated one horsepower or greater, Motor Test Data Sheets shall be submitted. All values shall be from tests of previously manufactured, electrically duplicate motors or calculated data. Sheets shall be marked to indicate motor application location, manufacturer, type, frame size, bearing type, lubrication medium and enclosure type. Sheets shall include:
    - a. Winding resistances.
    - b. Torques.
    - c. Efficiencies.
    - d. Power factors.
    - e. Slip.
    - f. Full load.
    - g. Locked rotor and no load amperes.
    - h. Rotor voltage and amperes for wound rotor units.
    - i. Nameplates temperature and results of dielectric tests.
  - 4. An outline drawing or an outline data sheet showing complete motor dimensions shall be submitted to cover every motor rated greater than 1/3 horsepower. Several motors of the same type and rating for the same application may be covered by a single drawing or outline sheet.

Drawings or sheets shall bear complete identifying data including frame size, speed, horsepower ratings and application for each particular unit.

5. Description of proposed shop and field testing methods, procedures and apparatus with calibration dates shall be submitted. Testing methods and procedures shall be submitted at least 45 days in advance prior to conformation of witness testing dates and actual testing.
6. Qualifications of proposed testing firm to perform acceptance testing shall be submitted. Submit firm experience records at least 45 days in advance to actual testing, five recent references with phone numbers shall be submitted.
7. All motor accessories, heaters, detectors, etc., shall be submitted.

**B. Certificates of Compliance:**

1. Certified copies of motor characteristic curves and all other data necessary for establishing control and protective equipment settings shall be submitted.
2. Results of shop tests shall be certified. When routine tests are made in conjunction with complete initial tests, unwitnessed results shall be certified and copies shall be submitted. Results shall be included for each test.
3. Data and results of witness tests shall be submitted with copies of certified initial tests, accompanied by a certificate of authenticity sworn to before a notary public by an officer of the manufacturing company. Upon approval, release for shipment to site shall proceed and the Engineer shall be notified of the arrival date.

**C. Reports:**

1. Shop test and field test reports shall be submitted.
2. Manufacturer's site visit and acceptance testing reports shall be submitted.

**D. Operation and maintenance manuals shall be submitted in accordance with the Detailed Specifications.**

**1.08 QUALITY ASSURANCE**

**A. General:**

1. The motor manufacturer shall maintain a documented Quality Assurance Program implementing suitable procedures and controls to monitor all aspects of production and testing. The Quality Assurance Program shall be the manufacturer's standard program specifically dedicated to ensure each motor is designed, assembled and tested in accordance with the requirements specified.

## GENERAL SPECIFICATION 16221 - ELECTRIC MOTORS

---

2. Motor manufacturer shall use a shop test facility that has calibrated testing apparatus, a dynamometer and qualified experienced technicians for all shop tests. Calibration of testing apparatus shall be within one year.
3. All test equipment, instrument calibration and test reports shall be in accordance with the latest edition of the accuracy standard of The U.S. National Institute of Standards and Technology and NETA acceptance testing specification.
4. Nameplates shall be provided for each motor. Nameplates shall clearly indicate information in accordance with NEMA requirements. Nameplates shall be engraved or embossed on stainless steel and fastened to the motor frame with stainless steel screws or drive pins.

### B. Field Tests:

1. The motors shall be field tested. Field testing shall be performed in accordance with the requirements specified under this Section.
2. Retain the services of the motor manufacturer for field service. Field service shall be in accordance with the requirements specified under this Section.
3. For motors larger than 200 horsepower an independent testing firm shall be retained to perform acceptance testing of the motors. The testing firm shall have experience in the inspection and testing of motors and shall be a member company of NETA. Provide proof of membership or demonstrate that the standards and experience required for membership are possessed, all to the satisfaction of the Engineer. Acceptance testing shall be in accordance with the requirements specified under this Section.

### 1.09 DELIVERY, STORAGE AND HANDLING

- A. Electric motors shall be delivered, stored and handled in accordance with the Detailed Specifications, the motor manufacturer's instructions and the following:
  1. Motors shall be inspected for shipping damage when received.
  2. All sleeve or oil lubricated bearings motors shall be identified and the bearing reservoirs filled to normal level.
  3. Motors shall be handled using motor base lifting lugs. Avoid pounding or bumping of motor which may damage motor. A hoist and spreader bar arrangement shall be used to avoid damage.
  4. Motors shall be stored indoors in clean, dry heated areas.



## GENERAL SPECIFICATION 16221 - ELECTRIC MOTORS

---

5. Motor space heaters shall be energized to prevent moisture condensation throughout the storage and construction period.
6. Motors shall not be stored in areas subject to continuous vibration. A small quantity of grease shall be injected into each bearing on a monthly basis. Purged grease shall be inspected for water or rust. Motor shaft shall be rotated by hand to check for binding.

### 1.10 SPARE PARTS

- A. The Contractor shall furnish and deliver to the Engineer, at that part of the site and at such time as the Engineer may direct, spare parts for the electric motors in accordance with the Detailed Specifications.
- B. The spare parts shall be listed in an index and packed in containers suitable for long term storage, bearing labels clearly designating the manufacturer's part number with complete information for use and reordering.
- C. Spare parts shall be furnished in accordance with the manufacturer's recommendations for the motor size and type. Spare parts shall include at a minimum the following:
  1. One set of brushes shall be provided for each DC type motor and wound rotor type motor requiring them.
  2. One complete set of bearing linings, or renewable ball or roller bearings shall be provided for each three (or less) of each type and size of motor. Spare bearings shall be furnished for all motor types. When sleeve bearing motors are provided, spare oil rings shall be furnished for those motors.
  3. One complete assembly of brush holders and supports shall be provided for each size of DC type motor and wound rotor type motor requiring them.
  4. One complete assembly of collector rings shall be provided for each size of wound rotor type motor requiring them.
  5. One complete set of fans and guards shall be provided (per each set of three or less) for each size totally enclosed fan cooled type motor.
  6. One set of bearing temperature detectors shall be provided (per each set of three, or less) of each type of motor 250 horsepower and larger.
  7. One set of upper and outer seal assemblies shall be provided (per each set of three or less) for each size submersible type motor.
  8. One set of O ring kit shall be provided (per each set of three or less) for each size submersible type motor.
  9. One set of wear rings shall be provided (per each set of three or less) for each size submersible type motor.

## GENERAL SPECIFICATION 16221 - ELECTRIC MOTORS

---

- D. Lubricants: The Contractor shall furnish as part of the bulk lubricant order the quantity of lubricants required to operate and maintain the motors furnished under this section for a period of one year after acceptance. As a minimum, there shall be provided sufficient oil and grease to make a least one lubricant change for each motor as applicable. Replace all lubricants used during startup and testing prior to acceptance of equipment. Furnish this replacement lubricant in addition to the lubricants included in the bulk order.

### PART 2 PRODUCTS

#### 2.01 SINGLE PHASE AC MOTORS

- A. Unless otherwise specified in the Detailed Specifications, single phase motors shall be rated 115 or 230 volt, capacitor start. Small fan motors may be split-phase or shaded pole type if such are standard for the equipment.
- B. Bearings for single phase, open, enclosed and explosion-proof motors shall be grease lubricated ball type with grease fittings or with lubrication for 10 years of normal operation.
- C. Motors shall be totally-enclosed except small fan motors may be open type if suitably protected from moisture, dripping water, and lint accumulation. Motor features shall be in accordance with the following:
1. Open motors shall be split phase or capacitor start in accordance with torque requirements, 1.35 Service Factor, 40 degrees C Ambient Class B Insulation.
  2. Enclosed motors shall be capacitor start, fan cooled 1.15 service factor, 40 degrees C ambient, Class F, treated insulation. Enclosed motors shall be totally enclosed fan cooled, or non-ventilated. Enclosed motors shall be designed to withstand chemical corrosion and shall be severe duty type equipped with cast iron end shields, neoprene gaskets, stainless steel shaft, heavy pressed steel fan cover and provision for threaded conduit connection.
  3. Explosion-proof motors shall be fan cooled, split phase or capacitor start in accordance with torque requirements, 1.0 service factor, 40 degrees C ambient, equipped with swivel conduit connector and long leads for external connection.
  4. Direct drive fan motors shall be shaded pole or permanent split capacitor, 1.35 service factor, 40 degrees C ambient.

#### 2.02 THREE PHASE AC MOTORS

- A. General:
1. Three phase motors shall be squirrel cage induction type, designed for operation on a 3 phase, 60 hertz alternating current system. Motor

voltage and where required adjustable frequency operation shall be as stated in the Detailed Specifications and the Drawings.

2. Unless otherwise required by the load, all motors shall be NEMA Design B, normal starting torque. Locked rotor KVA/HP shall not exceed NEMA Code Letter G for 20 HP motors and larger.
3. The design of the stator, rotor and shaft shall be in accordance with the approved practice of leading manufacturers. The motor frame shall be a rigid structure, designed to maintain the lamination in correct alignment and shall not be dependent on the lamination or bolts for rigidity.
4. Motors having considerable core length shall be provided with approved means for taking up shrinkage in length.
5. Motor rotors shall be of cast or fabricated aluminum or fabricated copper or copper alloy as required to meet the motor performance characteristics of slip, torque, and efficiency.
6. Unless otherwise specified in the Detailed Specifications, three phase squirrel cage motors shall be severe duty totally enclosed. Severe duty motors shall conform to the requirements of IEEE Standard 841.

### B. Bearings:

1. Horizontal motors shall be provided with either the rolling element (anti-friction) or sliding element (sleeve) type bearings. Anti-friction type bearings shall be used for all NEMA frame motors. Where greater power and speeds are required by the driven equipment, sleeve type bearings shall be used. The bearings for all motors larger than 200 horsepower shall be insulated to prevent shaft currents and related bearing damage.
2. Bearings for 3 phase drip-proof, enclosed and explosion-proof motors shall be grease lubricated, ball type. Bearings shall be fitted with inlet fittings and outlet plugs. Motor bearings and grease reservoirs shall be protected from the entry of contaminants.
3. Bearings for direct drive fan motor shall be of the oil lubricated sleeve type.
4. When anti-friction bearing are furnished on horizontal motors for ratings to 500 horsepower and speeds to 3600 RPM they shall have a minimum bearing life of 100,000 hours as defined by AFBMA. Suitable fittings shall be provided to permit convenient positive purging of old grease during regreasing operation. Close running shaft seals shall prevent leakage of grease as well as prevent the entrance of foreign materials such as water and dirt into the bearing area. Motors equipped

## GENERAL SPECIFICATION 16221 - ELECTRIC MOTORS

---

with anti-friction bearings shall have the appropriate AFBMA number stamped on a nameplate attached to the motor.

5. When furnished, sleeve bearings shall be ring-oiled with an adequate, integral self-cooled oil reservoir. The bearing sleeves shall be lined with a high tin content babbitt to minimize oil contamination. Close running shaft seals shall prevent oil leakage as well as prevent entrance of foreign material such as water and dirt into the bearing area. Oil level sight gages with permanently marked easily discernible oil level shall be provided. In addition, inspection openings to observe the oil rings shall also be provided.
6. When required by motor speed and bearing size, provision shall be made for forced lubrication. The oil supply shall be supplied with motor. In addition, oil rings and an adequate oil reservoir in the bearing housings shall be provided to permit orderly shutdown of the motor in the event of failure of the forced feed lubrication system.
7. Vertical motors shall be provided with thrust bearings adequate for all thrusts to which they can be subjected. The rated minimum life of the thrust bearings shall be at least 15,000 hours when operated at rated speed and full load thrust. The driven equipment manufacturer shall supply the motor manufacturer with the speed and thrust conditions required by the driven equipment.
8. Submersible motor bearings shall be permanently sealed and lubricated. Anti-friction guide and thrust bearings shall be replaceable. Bearings shall have a rated minimum life of 15,000 hours.

### C. Insulation:

1. The insulation system for three phase AC motors shall be rated Class F, with a service factor of 1.15 times the nameplate horsepower rating when operated on a sine wave supply and a service factor of 1.0 on an adjustable frequency supply. Temperature rise shall be limited to Class B insulation system when motor is operated continuously at rated horsepower with an ambient temperature not exceeding 40 degrees C.
2. Windings shall be epoxy coated. The windings shall be thoroughly treated with approved insulating compound suitable for protection against moisture, salt air and slightly acid or alkaline conditions. The insulation system for enclosed motors shall be upgraded by additional dips and bakes to increase moisture resistance.
3. Motors for outdoor service and all motors larger than 200 horsepower shall have vacuum/pressure impregnated epoxy insulation (VPI) for moisture resistance. Motors shall be preheated before VPI and baked in a temperature controlled oven.

## GENERAL SPECIFICATION 16221 - ELECTRIC MOTORS

---

4. Motors applied in speed varying service and operated from variable frequency drives shall have an inverter grade insulation system designed and built in accordance with NEMA MG1 Part 31.
5. The stator windings and end turn connections shall be fully brazed to withstand full voltage starting regardless of the starting method indicated in the Detailed Specifications. The bracing system shall essentially eliminate coil vibration under the high current conditions of starting as well as during normal operation. If a tied system is used, it shall be such that no tie depends on the integrity of any other tie within the system.
6. Motors larger than 200 horsepower shall be form wound. Form wound coils with a micaceous ground wall insulation is required with additional insulation similar to Mica 5 and hot pressed to make a sealed system. Coils shall be form wound with mica insulation and each separate coil shall be vacuum pressure impregnated before inserting into slots.

### D. Enclosures:

1. Wound rotor motors shall be drip-proof, except for crane and hoist installations and where specified otherwise.
2. Motors shall have a steel or cast iron frame and a cast iron or steel conduit box. For wound rotor motors separate boxes for stator and rotor connections shall be provided. For NEMA frame size motors cast aluminum frames and terminal boxes may be used.
3. Motor enclosures shall conform to the NEMA classifications specified and to the following:
  - a. Open Drip proof: Motors shall have a steel or cast iron frame, cast iron end brackets and steel conduit box. Vertical motors of the open type shall be provided with drip hoods of approved shape and construction. When the drip hood is too heavy to be easily removed, provision shall be made for access for testing. Open motors shall be provided with corrosion resistant screens over the air openings in accordance with NEMA requirements for guarded machines.
  - b. Totally enclosed fan cooled and non-ventilated motors shall have a cast iron frame, cast iron end brackets and cast iron conduit box. Drain holes shall be provided on each end of motor.
  - c. Explosion proof motors shall have a cast iron frame, cast iron end brackets and cast iron conduit box. Unless shown otherwise on the Contract Drawings or stated in the Detailed

## GENERAL SPECIFICATION 16221 - ELECTRIC MOTORS

---

- Specifications, explosion proof motors shall be UL listed for Class 1, Division 1, Group D hazardous areas.
- d. Severe duty motors shall include a corrosion resistant treatment. Severe duty motors shall have a cast iron frame, cast iron end brackets, cast iron conduit box, stainless steel "T" drains in both end brackets, corrosion resistant fan, and stainless steel hardware.
  - e. Submersible motors shall be hermetically sealed, watertight with tandem mechanical seals suitable for continuous submergence and listed for Class 1, Division 1, Group D locations.
4. Motor conduit box shall be split from top to bottom and shall be capable of being rotated to four positions. Motor conduit box shall be in accordance with the following:
- a. Conduit box shall be gasketed and shall include rubber-like gaskets between the frame and the conduit box and between the conduit box and its cover.
  - b. Conduit boxes or openings in motor housings shall be provided with conduit hub type fittings to permit threaded conduit connections. Single phase, explosion-proof and direct drive fan motors shall be provided with conduit fittings and leads to permit external connection.
  - c. Conduit box sizes shall be in accordance with code requirements. This shall include high-voltage terminations or stress cones. Protective and auxiliary devices, shall terminate in auxiliary conduit boxes for motors rated above 600 volt.
  - d. Terminal leads shall be flexible and shall be of sufficient length to extend for a distance of not less than ten inches beyond the face of the terminal box. Terminal leads shall be fitted with solder less lugs suitable for attachment to lugs installed on external wiring. Leads shall be sealed with a non-wicking, non-hygroscopic insulating material or an insulating "wrap-cap" as manufactured by Ideal Industries.
  - e. Provisions for terminal box size, length of leads, size of conduit openings and type of terminal lugs shall be complied with irrespective of any other standards or practice.
  - f. A motor frame grounding stud shall be provided inside the conduit box. A drilled and tapped hole shall be included.

## GENERAL SPECIFICATION 16221 - ELECTRIC MOTORS

---

### 2.03 DC MOTORS

#### A. General:

1. DC motors shall be designed and built in accordance with NEMA Standard MG1-12 for use on a full wave, single phase, rectified power supply.
2. DC motors shall be heavy duty, industrial SCR drive type, direct current. Motor construction shall be shunt-wound or permanent-magnet type as stated in the Detailed Specifications.
3. DC motors shall provide a constant torque output over the operating speed range, with fixed shunt excitation and variable DC armature voltage.

#### B. Bearings shall be grease lubricated, double shielded, with shaft seals.

#### C. Insulation:

1. The insulation system for DC motors shall be Class F, with a service factor of 1.15 times the nameplate horsepower rating.
2. The windings shall be epoxy coated and include a thermostat protector. Thermostat shall be in accordance with the requirements specified under this Section.

#### D. Enclosures:

1. DC motor enclosure shall be totally enclosed fan cooled, or non-ventilated. The frame size shall be selected by the manufacturer to prevent overheating when continuously operated at low speeds.
2. Motor enclosures shall be severe duty type, designed to withstand chemical corrosion, and shall utilize corrosion resistant materials for special finishes in their construction. Motors shall be equipped with cast iron end shield, neoprene gaskets, stainless steel shaft, heavy pressed steel fan cover and provisions for threaded conduit connection.
3. When stated in the Detailed Specification, the motor enclosure shall be fitted with a factory mounted tachometer generator. The generator shall be C-face or flange mounted construction.

### 2.04 ACCESSORIES

#### A. General:

1. Motor accessories shall be provided in accordance with the requirements specified under this section unless otherwise stated in the Detailed Specifications.
2. Each outdoor motor 5 horsepower and larger shall be provided with space heaters. 5 horsepower and larger enclosed motors installed

## GENERAL SPECIFICATION 16221 - ELECTRIC MOTORS

---

indoors in damp, unheated spaces shall also be provided with space heaters.

3. Winding thermal protection, thermostat type shall be provided for each motor in accordance with the following:
  - a. Submersible motors and explosion proof motors.
  - b. Variable speed motors up to 25 horsepower.
4. Winding thermal protection, thermistor type shall be provided for each motor in accordance with the following:
  - a. Constant speed motors 50 horsepower and larger up to 200 horsepower.
  - b. Variable speed motors 30 horsepower and larger up to 200 horsepower.
5. Space heaters, stator and bearing temperature detectors shall be provided for each motor 250 horsepower and larger.
6. Cranes, elevators, hoists, and other devices complying with special safety codes shall be furnished complete with their control equipment, and with all accessories and safety devices for approved safe and efficient operation.

### B. Space Heaters:

1. Space heaters for condensation prevention shall be rated 120 volt. Wattage shall be suitable for the particular frame size and type in accordance with the manufacturer's recommendation.
2. Space heater wire leads shall be brought out to an auxiliary conduit box on the motor. Box construction shall match main power conduit box.

### C. Winding thermal protection shall be in accordance with the following:

1. Thermostats shall be bi-metal disk or rod type embedded in the stator windings. Thermostat contacts shall be automatic reset type, rated 120 volt AC, 5 amps minimum opening on excessive temperature.
2. Thermistors embedded in each stator phase winding shall be in direct contact with the winding conductors. Each thermistor circuit shall be factory wired to 120 volt solid state control module mounted at the motor in a NEMA 4X box. The control module contacts shall be automatic reset type, rated 120 volt AC, 5 amps minimum opening on excessive temperature.
3. Resistance temperature detectors shall be 100 ohm precision type with calibrated resistance-temperature characteristics. Detectors, two per phase, shall be positioned to detect highest winding temperature and



## GENERAL SPECIFICATION 16221 - ELECTRIC MOTORS

---

located between coil sides in stator slots. Detector leads shall be wired to a separate NEMA 4X terminal box.

- D. Bearing Temperature Protection: Bearing temperature detectors RTD type similar to the winding detectors specified under this Section shall be provided on each bearing for horizontal motors and on the thrust bearing for vertical motors.
  - E. Single Phase Motors: Single phase motors requiring auxiliary starting resistors, capacitors or reactors and switching devices shall be furnished as combination units with such auxiliaries either incorporated within motor housings or housed in suitable enclosures, mounted upon motor frames. Each combination unit shall be mounted upon a single base and shall be provided with a single conduit box.
- 2.05 PAINTING
- A. External Surfaces:
    - 1. All severe duty motors shall have all external surfaces pretreated, primed and painted. External surfaces shall be pretreated so the surface is clean and free of contaminants. After pretreatment, the surface shall be primed with an oxide primer and then spray painted with a minimum of .003 inch thick epoxy polyamide and semi-gloss coating that is chemical, solvent, salt water, and acid resistant.
    - 2. All other motors shall have external surfaces pretreated, primed and painted in accordance with the manufacturer's standard treatment.
  - B. Internal Surfaces:
    - 1. All severe duty motors shall have all internal surfaces pretreated, primed and painted. Internal surfaces shall be pretreated so the surface is clean and free of contaminants. After pretreatment, the surface shall be primed with an oxide primer and then painted with an epoxy paint. Machined joints and threaded parts shall be coated with rust inhibiting compound.
    - 2. All other motors shall have internal surfaces pretreated and primed in accordance with the manufacturer's standard treatment.
  - C. All machined bolts and screws and other hardware shall be of the hex head type and shall be zinc plated. Stainless steel hardware shall be used on severe duty motors.

### 2.06 SHOP TESTS

- A. Certified Shop Tests:
  - 1. Shop testing shall be performed on the motors at the manufacturer's plant prior to shipment. Shop test shall be in accordance with the latest revisions of NEMA MG1 and shall demonstrate that the equipment

## GENERAL SPECIFICATION 16221 - ELECTRIC MOTORS

---

tested conforms to the requirements specified inclusive of the efficiency requirements stated in this Section.

2. The Contractor shall provide a shop test report. The report shall identify the tests performed and the results obtained.
3. Every motor rated less than 200 horsepower shall be given a routine test at the manufacturer's factory. The routine test shall consist of:
  - a. No Load Speed, Voltage and Current at rated frequency.
  - b. Locked Rotor Current.
  - c. Winding Resistance.
  - d. High Potential.
  - e. Bearing Inspection.
  - f. Measurement of Secondary Volts at standstill for wound-rotor units.
4. Motors rated at 200 horsepower or greater shall be given complete initial tests consisting of:
  - a. Full-load Heat Run.
  - b. Percent Slip.
  - c. No Load Speed, Voltage, Current and losses at rated frequency.
  - d. Full Load Current.
  - e. Locked rotor Torque.
  - f. Locked-rotor Current.
  - g. Breakdown Torque (Calculated).
  - h. Starting Torque (squirrel-cage).
  - i. Winding Resistance.
  - j. High Potential.
  - k. Sound.
  - l. Vibration.
  - m. Efficiencies at 125, 100, 75 and 50 percent of full load.
  - n. Power Factors at 125, 100, 75 and 50 percent of full load.
  - o. Bearing Inspection.
  - p. Measurement of Secondary Volts at collector rings for wound-rotor units.

### B. Witnessed Shop Tests:

## GENERAL SPECIFICATION 16221 - ELECTRIC MOTORS

---

1. The Contractor shall perform witnessed shop tests in accordance with the Detailed Specifications.
2. When stated in the Detailed Specifications, motors shall be witness tested. Motors shall be given a complete test two weeks before and then retested in the presence of the witness.
3. When complete initial or witness tests are required for a group of the same type, rating and horsepower for the same application, all units of the group shall be subjected to the complete test, unless specifically stated otherwise in the Detailed Specifications.

### PART 3 EXECUTION

#### 3.01 INSTALLATION

- A. Motors shall be installed in accordance with manufacturer's instructions and recommendations.
- B. Each motor shall be carefully and properly aligned with the driven equipment.
- C. Equipment shall be secured to mounting surface with anchor bolts. Anchor bolts shall be provided meeting manufacturer's recommendations and of sufficient size and number to secure equipment.
- D. Motor nameplates shall be installed for identification of equipment. Nameplates shall be provided in accordance with the requirements of General Specification 15076 - Piping and Equipment Identification.

#### 3.02 FIELD TESTS

- A. After installation, motors shall be field tested for operation and conformance. The Contractor shall perform field tests in accordance with the Detailed Specifications. The field tests shall be witnessed by the Engineer and certified by the Contractor.
- B. Motor testing shall be performed by the manufacturer's representative, prior to energizing equipment. Equipment shall not be energized without the permission of the Engineer. The testing shall be in accordance with the recommendations of the manufacturer's representative and shall include at a minimum the following:
  1. Motors shall be checked to determine that they have been properly installed, lubricated and connected.
  2. Motors shall be checked to determine they are not overloading, overheating or defective.
  3. Motors shall be checked to determine they comply with performance and design parameters.

3.03 MANUFACTURER'S FIELD SERVICES

- A. A qualified manufacturer's service representative shall assist in the installation of the motors, check the motor installation before it is placed into operation, assist in the performance of field tests, observe and assist initial operations and train the plant operations and maintenance staff in the care, operation and maintenance of the motors.
- B. The Contractor shall provide equipment start-up services and training in accordance with the Detailed Specifications.
- C. The Contractor shall provide a field report from the manufacturer's representative for each visit to the site. The report shall include complete information on time, schedule, tasks performed, persons contacted, problems corrected, tests results, training, instruction and all other pertinent information.
- D. The service representative shall sign in with the Engineer on each day they are at the site.

3.04 ACCEPTANCE TESTING

- A. The Contractor shall provide acceptance testing of the motors. All acceptance testing shall be performed by the testing firm, after the completion of the Field Tests specified under this Section. The acceptance testing shall be witnessed by the Engineer and certified by the Contractor.
- B. Acceptance testing inspection shall be performed on each motor larger than 200 horsepower. Inspection shall include the following:
  - 1. Electrical and grounding connections shall be inspected.
  - 2. Shaft alignment, proper mounting and lubrication shall be inspected.
  - 3. Ventilating air passageways shall be inspected for blockage.
  - 4. Excessive noise shall be inspected.
  - 5. Any overheating shall be inspected.
  - 6. Correct rotation shall be inspected.
  - 7. Protective detectors operation shall be checked.
  - 8. Any excessive vibration shall be checked.
  - 9. Space heater operation shall be checked.
- C. Acceptance electrical testing shall be performed on each motor larger than 200 horsepower. Testing shall include the following:
  - 1. Insulation resistance tests shall be performed.
  - 2. Surge comparison testing shall be performed.
  - 3. Vibration tests shall be performed.

## GENERAL SPECIFICATION 16221 - ELECTRIC MOTORS

---

4. Bearing insulation resistant tests on insulated bearings shall be performed.
  5. Running current and voltage shall be measured and evaluated relative to load conditions and nameplate full-load amperes.
  6. High-potential tests shall be performed.
  7. For wound rotor motors, additional electrical testing at minimum and normal operating load points and at ring short shall be performed.
  8. Motors shall be operated with driven equipment for a minimum of 48 continuous hours and rechecked for overheating and vibration.
- D. All tests and values for AC and DC motors shall be in accordance with the manufacturer's recommendations and NETA ATS.
- E. The Contractor shall provide an acceptance testing report. The report shall be in accordance with NETA ATS.

END OF SECTION

NO TEXT ON THIS PAGE

**SECTION 16271  
Dry Type Transformers**

**PART 1 GENERAL**

**1.01 SECTION INCLUDES**

- A. Requirements for providing individually mounted dry type transformers. Dry type transformers shall be provided in accordance with the requirements specified under this Section, the Detailed Specifications and the Contract Drawings.
- B. The following index of this Section is included for convenience:

<u>Article</u>	<u>Title</u>	<u>Page</u>
		16271-
PART 1	GENERAL.....	1
1.01	SECTION INCLUDES.....	1
1.02	PAYMENT.....	1
1.03	RELATED SECTION.....	1
1.04	REFERENCES.....	2
1.05	SUBMITTALS.....	2
1.06	QUALITY ASSURANCE.....	2
1.07	DELIVERY, STORAGE AND HANDLING.....	3
PART 2	PRODUCTS.....	3
2.01	MANUFACTURERS.....	3
2.02	GENERAL PURPOSE TRANSFORMERS.....	3
2.03	SHIELDED ISOLATION TRANSFORMERS.....	3
2.04	NON-LINEAR LOAD TRANSFORMERS.....	4
2.05	SEISMIC REQUIREMENTS.....	4
2.06	SHOP TESTS.....	4
PART 3	EXECUTION.....	4
3.01	INSTALLATION.....	4
3.02	FIELD TESTS.....	5

**1.02 PAYMENT**

- A. Payment for dry type transformers shall be made as provided for in the Detailed Specifications.

**1.03 RELATED SECTION**

- A. General Specification 16061 - Grounding
- B. General Specification 16071 - Supporting Devices
- C. General Specification 16076 - Labeling and Identification

## GENERAL SPECIFICATION 16271 – DRY TYPE TRANSFORMERS

---

### 1.04 REFERENCES

- A. Dry type transformers shall comply with the latest applicable provisions and recommendations of the following:
1. NYCEC - New York City Electrical Code.
  2. UL Standard No. 1561 - Dry-Type General Purpose and Power Transformers.
  3. NEMA ST 20 - Dry Type Transformers for General Application.

### 1.05 SUBMITTALS

- A. Contractor shall submit Shop Drawings and material specifications for the approval of the Engineer. Submittals shall include, but not be limited to:
1. Manufacturer's catalog cuts for the transformers proposed for use.
  2. Dimensional drawings showing transformer details with diagrammatic nameplate.
  3. Transformer anchorage and mounting details prepared and stamped by a licensed engineer.
  4. Description of shop and field testing methods, procedures and apparatus with calibration dates shall be submitted. Testing methods and procedures shall be submitted at least 45 days in advance prior to conformation of witness testing dates and actual testing.
- B. Shop test and field test reports shall be submitted.
- C. Operations and Maintenance Manuals shall be submitted in accordance with the Detailed Specifications.

### 1.06 QUALITY ASSURANCE

- A. General:
1. All transformers shall conform to the applicable NEMA, ANSI and IEEE Standards and shall be built by one approved manufacturer who shall use only best commercial materials and processes of manufacture. Transformer enclosures shall have ample room for primary and secondary wiring connections.
  2. Transformers manufacturer shall certify that the transformer can withstand the vertical and lateral response spectra
  3. All transformers shall be UL listed and certified to ANSI/NEMA sound levels.
  4. The transformer manufacturer shall use a shop test facility that has recently calibrated testing apparatus and qualified, experienced



## GENERAL SPECIFICATION 16271 – DRY TYPE TRANSFORMERS

---

technicians, for all shop tests. Calibration of testing apparatus shall be within one year of date of testing.

5. All test equipment and instrument calibration shall be in accordance with the latest edition of the accuracy standard of the U.S. National Institute of Standards and Technology.

- B. Field testing of the transformers shall be performed in accordance with the requirements specified under this Section.

### 1.07 DELIVERY, STORAGE AND HANDLING

- A. Dry type transformers shall be delivered, stored and handled in accordance with the Detailed Specifications and the manufacturer's recommendations.

## PART 2 PRODUCTS

### 2.01 MANUFACTURERS

- A. Dry type transformers shall be as manufactured by:
  1. Eaton, Cleveland, OH.
  2. General Electric Company, Stamford, CT.
  3. Or approved equal.

### 2.02 GENERAL PURPOSE TRANSFORMERS

- A. General purpose transformers shall be of the dry, commercially quiet, low temperature rise type consisting of two windings per phase. Conductors for transformer windings shall be copper only. Transformers shall be suitable for indoor or outdoor installation in accordance with the locations shown on the Contract Drawings.
- B. Transformers shall have KVA rating, primary voltage and connection, secondary voltage and connection and number of phases as shown on the Contract Drawings.
- C. Transformer insulation shall be rated 220 degrees C, 80 degrees C rise.
- D. Transformers shall be equipped with six 2-1/2 percent fully rated taps, two above and four below the rated voltage tap on the primary winding. The arrangement, assembly, and laminations of the core shall be such as to facilitate repair to the windings. The design, shape, and arrangement of windings shall allow free flow of air for insulation and cooling.

### 2.03 SHIELDED ISOLATION TRANSFORMERS

- A. Shielded isolation transformers shall conform to the requirements specified under this Section for General Purpose Transformers and the following:
  1. Shielded isolation transformers shall also include an electrostatic shield, grounded to the transformer case, to attenuate noise.

## GENERAL SPECIFICATION 16271 – DRY TYPE TRANSFORMERS

---

### 2.04 NON-LINEAR LOAD TRANSFORMERS

- A. Non-linear load transformers shall conform to the requirements specified under this Section for General Purpose Transformers and the following:
  - 1. Non-linear load transformers shall be specifically designed for non-sinusoidal loads. Transformers shall be K-factor rated as shown on the Contract Drawings or stated in the Detailed Specifications.
  - 2. Oversize neutral suitable to handle at least 200 percent of normal phase current.

### 2.05 SEISMIC REQUIREMENTS

- A. The transformer mounting system shall be designed, constructed and installed suitable for earthquake regulations in accordance with the seismic requirements of the New York City Building Code.
- B. Transverse and longitudinal bracing shall be provided as required to brace the transformer for the seismic requirements specified.

### 2.06 SHOP TESTS

- A. Shop tests shall be performed at the transformer's manufacturer's plant prior to shipment. Shop tests shall demonstrate that the equipment tested conforms to the requirements specified.
- B. Each transformer shall be given a routine test in accordance with the latest requirements of UL, ANSI and NEMA standards.
- C. The Contractor shall provide a shop test report. The report shall identify the tests performed and the results obtained.
- D. Transformer shop tests shall be performed consisting of the following:
  - 1. Applied potential shall be performed.
  - 2. Induced potential shall be performed.
  - 3. No load losses shall be performed.
  - 4. Voltage ratio shall be performed.
  - 5. Polarity shall be performed.

## PART 3 EXECUTION

### 3.01 INSTALLATION

- A. Transformers shall be installed on walls or floors. Floor mounted transformers shall be installed on one inch of Korfund sound absorber material on raised concrete base at locations shown on the Contract Drawings. Sufficient access and working space shall be provided for ready and safe operation and maintenance.

## **GENERAL SPECIFICATION 16271 – DRY TYPE TRANSFORMERS**

---

- B. Transformers mounting, supports and restraints shall conform to the requirements of this Section and General Specification 16071 – Hangers and Supports.
  - C. Transformers shall be grounded in accordance with the requirements of General Specification 16061 – Grounding.
  - D. The transformer leads shall be provided with solderless, clamp type cable connectors. Conduit runs shall be arranged for easy removal of the transformers.
  - E. Transformer nameplates shall be Install for identification of equipment. Nameplates shall be provided in accordance with the requirements of General Specification 16076 - Labeling and Identification.
- 3.02 FIELD TESTS
- A. Insulation resistance tests shall be performed on the transformers after installation. The tests shall be witnessed by the Engineer and certified by the Contractor. The tests shall be performed by the Contractor who shall furnish all testing equipment.
  - B. The Contractor shall provide a field test report. The report shall identify the tests performed and the results obtained.

END OF SECTION

**GENERAL SPECIFICATION 16271 – DRY TYPE TRANSFORMERS**

---

NO TEXT ON THIS PAGE

**GENERAL SPECIFICATION 16292 - POWER DISTRIBUTION SYSTEM  
COORDINATION**

---

**SECTION 16292  
Power Distribution System Coordination**

**PART 1 GENERAL**

**1.01 SECTION INCLUDES**

- A. Requirements for providing power system studies and distribution system field testing. Power system studies and field testing shall be provided in accordance with the requirements specified under this Section, the Detailed Specifications and the Contract Drawings.
- B. The power system studies shall include a load flow study, a short circuit study, a protective device evaluation study and a protective device coordination study for a completely coordinated power distribution system.
- C. The following index of this Section is presented for convenience:

<u>Article</u>	<u>Title</u>	<u>Page</u>
		16292-
PART 1	GENERAL.....	1
1.01	Section Includes.....	1
1.02	Payment.....	1
1.03	Related Sections.....	1
1.04	References.....	2
1.05	Submittals.....	3
1.06	Quality Assurance.....	3
PART 2	PRODUCTS.....	4
2.01	Software.....	4
2.02	Power System Studies.....	4
2.03	Study Report.....	5
PART 3	EXECUTION.....	5
3.01	Application.....	5
3.02	Field Testing.....	8
3.03	Maintenance Of Operations.....	8

**1.02 PAYMENT**

- A. Payment for the power distribution system coordination shall be made as provided for in the Detailed Specifications.

**1.03 RELATED SECTIONS**

- A. General Specification 16055 - Shock Hazard and Arc Flash Studies

# GENERAL SPECIFICATION 16292 - POWER DISTRIBUTION SYSTEM COORDINATION

---

## 1.04 REFERENCES

### A. Definitions

1. Node – A node is any point in the electrical distribution system where two or more pieces of equipment connect.
2. Branch – Any element of the electrical distribution system connecting any two nodes.
3. Major Node – Any node representing actual real world connection points of branches of the electrical distribution system such as switchgear bus, MCC bus, or panelboard bus or motors.
4. Dummy Node – All fictitious nodes created within the modelling software to facilitate modelling of the electrical distribution system.
5. Major Branch – All branches representing actual real world elements of the electrical distribution system such as feeders and breakers.
6. Dummy Branch – All fictitious branches created within the modelling software to facilitate modelling of the electrical distribution system.

### B. Reference Standards

The power distribution system coordination shall comply with the latest applicable provisions and recommendations of the following:

1. NYCEC - New York City Electrical Code.
2. IEEE C37.04 - IEEE Standard Rating Structure for AC High Voltage Circuits Rated on a Symmetrical Basis
3. IEEE C37.010 - IEEE Application Guide for AC High Voltage Circuit Breakers Rated on a Symmetrical Basis
4. IEEE C37.13 - IEEE Standard for Low-Voltage AC Power Circuit Breakers Used in Enclosures.
5. IEEE 141 - IEEE Recommended Practice for Electric Power Distribution in Industrial Plants
6. IEEE 399 - IEEE Recommended Practice for Industrial and Commercial Power System Analysis
7. IEEE 1015 - IEEE Recommended Practice for Applying Low-Voltage Breakers Used in Industrial and Commercial Power Systems

**GENERAL SPECIFICATION 16292 - POWER DISTRIBUTION SYSTEM  
COORDINATION**

---

8. NETA ATS - NETA Acceptance Testing Specification.

1.05 SUBMITTALS

- A. Contractor shall submit Shop Drawings and material specifications for the approval of the Engineer. Submittals shall include, but not be limited to:
1. Calculations and results of the power system studies shall be submitted. The load flow study, short circuit study, protective device evaluation study and the protective device coordination study shall be submitted in a report format. The report shall be stamped and signed by the Licensed Engineer.
  2. Work sequence for the field testing shall be submitted. The sequence shall indicate the schedule of work, time frame and downtime for the equipment. The work sequence shall be submitted at least 45 days in advance prior to conformation of field testing dates.
  3. Qualifications of proposed testing firm to perform field testing shall be submitted. Submit firm experience records at least 45 days in advance to actual testing, five recent references with phone numbers shall be submitted.
- B. Reports: Field test report shall be submitted.

1.06 QUALITY ASSURANCE

- A. General:
1. The power system studies shall be performed in accordance with the latest applicable provisions and recommendations of the following:
    - a. NYCEC.
    - b. ANSI C37.04.
    - c. ANSI C37.010.
    - d. IEEE 141.
    - e. IEEE 399.
    - f. IEEE 1015
  2. The Contractor shall retain the services of a Professional Engineer, licensed in the State of New York, to perform the power system studies. The Licensed Engineer shall be from an independent consulting firm or the equipment manufacturer.

## GENERAL SPECIFICATION 16292 - POWER DISTRIBUTION SYSTEM COORDINATION

---

3. Power System Studies shall be completed using approved computer software programs. The software programs shall be by vendors who have been regularly engaged in the production of Power System Analysis software for the last 10 years.
4. The Contractor shall coordinate with the Engineer performing the studies and assist him in the collection of all information necessary to complete the studies specified.
5. All test equipment and instrument calibration shall be in accordance with the latest edition of the accuracy standard of the U.S. National Institute of Standards and Technology and the NETA ATS.

### B. Field Testing:

1. The power distribution system shall be field tested. The field testing shall be performed in accordance with the requirements specified under this Section.
2. Retain the service of an independent testing firm who shall perform field testing of the power distribution system. The testing firm shall have experience in the inspection and testing of the system equipment and shall be a member company of NETA. Provide proof of membership, or demonstrate that the standards and experience required for membership are possessed, all to the satisfaction of the Engineer.

## PART 2 PRODUCTS

### 2.01 SOFTWARE

#### A. The only software program to conduct power system studies shall be:

1. DesignBase 5.0 (or version approved by Engineer) by Power Analytics Corporation.

### 2.02 POWER SYSTEM STUDIES

#### A. General:

1. The Contractor shall provide a current and complete load flow study, short-circuit study, protective device evaluation, and a protective device coordination study for the electrical distribution system.
2. The studies shall include all portions of the electrical distribution system from the all normal and all alternate sources of power downstream to all load buses. Normal system operating method, alternate operation, and operations which could result in all



## GENERAL SPECIFICATION 16292 - POWER DISTRIBUTION SYSTEM COORDINATION

---

abnormal, maximum and minimum deviations at nodes and in branches shall be thoroughly covered in the studies.

3. Problem areas or equipment inadequacies shall be promptly brought to the Engineer's attention.

### 2.03 STUDY REPORT

A. The results of the power system studies shall be summarized in a final typewritten report. The report shall include the following Sections:

1. Description, purpose, basis, written scope, and a single-line diagram of the power distribution system which is included within the scope of the study.
2. Tabulations of load flow study results inclusive of normal, minimum and maximum branch loadings along with normal, minimum and maximum voltages at nodes.
3. Tabulations of circuit breaker, fuses, and other equipment ratings versus calculated short-circuit duties, and commentary regarding same.
4. Protective device time versus current coordination curves, tabulations of relay and circuit breaker trip settings, fuse selection, and commentary regarding same.
5. Fault current tabulation including a definition of terms and a guide for interpretation.
6. Tabulation of appropriate tap settings for relay seal-in units.

### PART 3 EXECUTION

#### 3.01 APPLICATION

A. Study Input

1. The Contractor shall ensure that all data to complete the load flow study, the short circuit study, the protective device evaluation study and the protective device coordination study is input to the software model including but not limited to:
  - a. Source including Utility and on site generation single and three phase contributions including X/R ratios.
  - b. Motor contributions and sequence impedances including X/R ratios.
  - c. Sequence resistance and reactance of all major branches
  - d. Transformer impedance, X/R ratios, winding connection, tap ranges and base ratings.

## GENERAL SPECIFICATION 16292 - POWER DISTRIBUTION SYSTEM COORDINATION

---

- e. All other circuit parameter to permit the complete and accurate modelling of the electrical distribution system.
  - f.
- B. Load Flow Study:
- 1. The load flow study shall be preliminary to all the other studies and for all proposed operating conditions of the electrical distribution system. The load flow study shall be used to
    - a. Preset the study parameters as applicable for each of the studies listed under this Section.
    - b. Confirm the layout and balance of the power flows across the major branches and the voltage profiles at all major nodes
    - c. Identify real and reactive power flows across the electrical distribution system.
    - d. Determine real and reactive power losses.
    - e. Identify proposed transformer tap settings.
    - f. Problem areas or equipment inadequacies shall be promptly brought to the Engineer's attention.
- C. Short Circuit Study:
- 1. Short-circuit momentary duties and interrupting duties shall be calculated on the basis of maximum available fault current at each major node and through major branches and other significant locations through the system.
  - 2. The short circuit tabulations shall include symmetrical fault currents, and X/R ratios. For each fault location, the total duty on the major bus, as well as the individual contribution from each connected branch, including motor back EMF current contributions shall be listed with its respective X/R ratio.
- D. Protective Device Evaluation Study:
- 1. The protective device evaluation study shall be performed to determine the adequacy of circuit breakers, controllers, surge arresters, busways, switches, and fuses by tabulating and comparing the short-circuit ratings of these devices with the available fault currents.
  - 2. Appropriate multiplying factors based upon system X/R ratios and protective device rating standards shall be applied.
- E. Protective Device Coordination Study:

## GENERAL SPECIFICATION 16292 - POWER DISTRIBUTION SYSTEM COORDINATION

---

1. The protective device coordination study shall be performed to select or to check the selections of the power fuse ratings, protective relay characteristics and settings, ratios and characteristics of associated voltage and current transformers, and low-voltage breaker trip characteristics and setting.
2. The overcurrent device settings computed in the coordination study shall provide complete selectivity. The system shall be selectively coordinated such that only the device nearest a fault will operate to remove the faulted circuit. System selectivity shall be based on both the magnitude and the duration of a fault current.
3. The coordination study shall include all voltage classes of equipment starting at the utility's incoming line protective device down to and including each of the medium and low voltage equipment. The phase and ground overcurrent and ground fault protection shall be included, as well as settings for all other adjustable protective devices.
4. The time-current characteristics of the installed protective devices shall be plotted on the appropriate log-log paper. Reasonable coordination intervals and separation of characteristic curves shall be maintained. The coordination plots for phase and ground protective devices shall be provided on a complete system basis. Sufficient curves shall be used to clearly indicate selective coordination achieved to the utility main breaker, power distribution feeder breakers, and the overcurrent devices at each major load center.
5. There shall be a maximum of six protective devices per plot. Each plot shall be appropriately titled. Plots shall include the following information as required for the circuits shown:
  - a. Representative one-line diagram, legends and types of protective devices selected.
  - b. Power company's relays or fuse characteristics.
  - c. Significant motor starting characteristics.
  - d. Parameters of transformers, ANSI magnetizing inrush and withstand curves.
  - e. Operating bands of low voltage circuit breaker trip curves, and fuse curves.
  - f. Relay taps, time dial and instantaneous trip settings.
  - g. Cable damage curves.
  - h. Symmetrical and asymmetrical fault currents.

## GENERAL SPECIFICATION 16292 - POWER DISTRIBUTION SYSTEM COORDINATION

---

6. The selection and settings of the protective devices shall be provided separately in a tabulated form listing circuit identification, IEEE device number, current transformer ratios, manufacturer, type, range of adjustment, and recommended settings. A tabulation of the recommended power fuse selection shall be provided for all fuses in the system.

### 3.02 FIELD TESTING

- A. The Contractor shall provide field testing of the distribution system. All field testing shall be performed by the testing firm, after the completion and approval of the power system studies. The field testing shall be witnessed by the Engineer and certified by the Contractor.
- B. The testing firm shall adjust, set, calibrate and test all protective devices. All protective relays and meters in the medium and low voltage equipment shall be set, adjusted, calibrated and tested in accordance with the manufacturer's recommendations, the coordination study and best industry practice.
- C. Proper operation of all equipment associated with the device under test and its compartment, shall be verified, as well as complete resistance, continuity and polarity tests of power, protective and metering circuits. Any minor adjustments, repairs and/or lubrication necessary to achieve proper operation shall be considered part of this Contract.
- D. All solid state trip devices shall be checked and tested for setting and operation. Circuit breakers and/or contactors associated with the trip devices shall be tested for trip and close function with their protective device.
- E. All tests shall be in accordance with the manufacturer's recommendations and NETA, ATS..
- F. The Contractor shall provide a field testing report. The report shall be in accordance with NETA, ATS..

### 3.03 MAINTENANCE OF OPERATIONS

- A. Since the field testing work specified shall require that equipment be taken out of service, the Contractor shall perform the work with due regard to maintenance of operations and construction staging in accordance with the Detailed Specifications. All testing procedures and schedules must be scheduled in advance prior to any work beginning.

END OF SECTION

**SECTION 16441  
Panelboards**

**PART 1 GENERAL**

**1.01 SECTION INCLUDES**

- A. Requirements for providing panelboards. Panelboards shall be provided in accordance with the requirements specified under this Section, the Detailed Specifications and the Contract Drawings.
- B. The panelboards shall include all power distribution, lighting, appliance and instrument panels.
- C. The following index of this Section is included for convenience:

<u>Article</u>	<u>Title</u>	<u>Page</u>
		16441-
PART 1	GENERAL .....	1
1.01	SECTION INCLUDES .....	1
1.02	PAYMENT .....	1
1.03	RELATED SECTION .....	1
1.04	REFERENCES .....	1
1.05	SUBMITTALS .....	2
1.06	QUALITY ASSURANCE .....	2
1.07	DELIVERY, STORAGE AND HANDLING .....	3
PART 2	PRODUCTS.....	3
2.01	MANUFACTURERS .....	3
2.02	PANELBOARDS .....	3
2.03	PAINTING.....	7
2.04	SHOP TESTS .....	7
PART 3	EXECUTION.....	7
3.01	INSTALLATION .....	7

**1.02 PAYMENT**

- A. Payment for panelboards shall be made as provided for in the Detailed Specifications.

**1.03 RELATED SECTION**

- A. General Specification 01411 - Envision Requirements
- B. General Specification 16076 - Labeling and Identification

**1.04 REFERENCES**

- A. Panelboards shall comply with the latest applicable provisions and recommendations of the following:

## GENERAL SPECIFICATION 16441 - PANELBOARDS

---

1. NYCEC New York City Electrical Code.
2. UL Standard No. 50 Enclosures for Electrical Equipment Non-Environmental Considerations.
3. UL Standard No. 50 Enclosures for Electrical Equipment Environmental Considerations.
4. UL Standard No. 67 Panelboards.
5. UL Standard No. 489 Molded-Case Circuit Breakers, Molded-Case Switches, and Circuit-Breaker Enclosures.
6. UL Standard No. 943 Ground Fault Circuit Interrupters.
7. NEMA PB1 - Panelboards.

### 1.05 SUBMITTALS

- A. Contractor shall submit Shop Drawings and material specifications for the approval of the Engineer. Submittals shall include, but not be limited to:
  1. Manufacturer's technical information for the panelboards proposed for use including all components.
  2. A listing of the panelboards with the number and size of circuit breakers identified.
  3. Dimensional drawings showing panelboard enclosure details.
  4. Panelboard anchorage details with design calculations signed by licensed Engineer.
- B. Certificates of Compliance: Seismic qualification certification from the manufacturer including mounting recommendations.
- C. Reports: Shop test reports shall be submitted.
- D. Operations and Maintenance Manuals shall be submitted in accordance with the Detailed Specifications.
- E. The Contractor shall report information pertaining to the sustainable procurement, regional sourcing, and recycled content of new materials to be procured during the Work, in accordance with General Requirements 01411 – Envision Requirements.

### 1.06 QUALITY ASSURANCE

- A. General:
  1. All panelboards shall conform to the applicable NEMA and UL Standards and shall be built by one approved manufacturer who

shall use only best commercial materials and processes of manufacture.

2. The manufacturer shall have produced panelboards for a minimum of five years.
  3. All panelboards shall be UL listed.
  4. The panelboards manufacturer shall use a shop test facility that has recently calibrated testing apparatus and qualified, experienced technicians, for all shop tests. Calibration of testing apparatus shall be within one year.
  5. All test equipment and instrument calibration shall be in accordance with the latest edition of the accuracy standard of the U.S. National Institute of Standards and Technology.
- B. The panelboards shall be designed, constructed and installed suitable for earthquake regulations in accordance with the seismic requirements of the City of New York Building Code.

1.07 DELIVERY, STORAGE AND HANDLING

- A. Panelboards shall be delivered, stored and handled in accordance with the Detailed Specifications and the manufacturer's recommendations.

PART 2 PRODUCTS

2.01 MANUFACTURERS

- A. Panelboards shall be as manufactured by:
1. Eaton, Cleveland, OH
  2. General Electric Company, Stamford, CT.
  3. Or approved equal.

2.02 PANELBOARDS

- A. General:
1. The panelboards shall be dead-front type with automatic trip-free, bolt-on, molded case circuit breakers.
  2. The panelboards shall be equipped with main breakers or main lugs, branch circuit breakers, 1-pole, 2-pole and 3-pole, as shown on the Contract Drawings.
  3. The panelboards shall be enclosed in flush or surface mounted cabinets as shown on the Contract Drawings.
- B. Ratings:

## GENERAL SPECIFICATION 16441 - PANELBOARDS

---

1. Panelboard ampacities, voltage, number of phases and wires shall be as shown on the Contract Drawings. Panelboard frequency shall be 60 Hz.
2. Panelboards shall be labeled with a UL short circuit rating. All panelboards shall be fully rated.
3. Panelboards rated 240VAC or less shall have a short circuit rating of 10,000A RMS symmetrical, unless shown otherwise on the Contract Drawings.
4. Panelboards rated 480VAC shall have a short circuit rating of 14,000A RMS symmetrical, unless shown otherwise on the Contract Drawings.

### C. Cabinets:

1. Cabinets shall be constructed of 12 gauge galvanized steel with stainless steel hardware.
2. Cabinets shall be NEMA 12 for dry, indoor areas and NEMA 4X for corrosive areas. In hazardous locations, panelboards shall have a NEMA 7 rating.
3. Cabinets shall have wiring gutters on the sides. Cabinets shall be at least 5-3/4 inches deep and 20 inches wide for panelboards with maximum branch circuit breakers of 100A. When branch circuit breakers are above 100A, cabinets shall be at least 9-1/2 inches deep and 31 inches wide.
4. Trims for panelboards shall consist of a hinged trim door which does not leave any live parts uncovered and permits the operation of all circuit breakers. In addition a door-in-door arrangement shall form the dead front panel door covering all parts not covered by the hinged trim door. Both doors shall have concealed hinges with flush type catches and locks. All locks shall be keyed alike.
5. Cabinets shall have identifying nameplates in accordance with the requirements of General Specification 16076 - Labeling and Identification.

### D. Bus Bars:

1. Bus bars shall be copper sized in accordance with UL standards to limit temperature rise on any current carrying part to a maximum of 65 degrees C above an ambient of 40 degrees C maximum.



## GENERAL SPECIFICATION 16441 - PANELBOARDS

---

2. Bus bar taps for single-pole branches shall be arranged for sequence phasing of the branch circuit devices.
  3. A bonded ground bus shall be included in all panels.
  4. Full-size neutral bars shall be provided for panelboards, unless noted otherwise on the Contract Drawings.
  5. Where specifically shown on the Contract Drawings or stated in the Detailed Specifications, panelboards shall be provided with a 200 percent rated neutral bus suitable for use with non-linear loads. Neutral busing shall have a suitable lug for each outgoing feeder requiring a neutral connection.
  - 6.
- E. Circuit Breakers:
1. Circuit breakers shall be the molded case type conforming to UL 489.
  2. Breakers shall be the heavy-duty, bolt-on type with quick-make quick-break toggle mechanism for manual as well as automatic operation.
  3. Breakers shall have 100 amp frames, with 15 amp trip elements as minimum, unless otherwise shown on the Contract Drawings. All 100 amp frame breakers shall be fixed thermal magnetic trip units. Frame sizes above 100 amp shall have interchangeable thermal magnetic trip units or electronic trip units.
  4. Where specifically shown on the Contract Drawings or stated in the Detailed Specifications, breakers shall be provided with electronic trip units. Electronic trip units shall provide long time, short time, instantaneous and ground fault settings and time adjustments as minimum.
  5. Where specifically shown on the Contract Drawings or stated in the Detailed Specifications, ground fault circuit interrupters shall be provided. Ground fault breakers shall be equipped with solid state sensing and 5 milliamp sensitivity.
  6. Breakers used for lighting circuit switching shall be suitable for the purpose and shall be marked "SWD". Breakers requiring continuous operation shall be provided with a lock-on device.
  7. Where specifically shown on the Contract Drawings or stated in the Detailed Specifications, shunt trips, bell alarms, and auxiliary devices shall be provided.
- F. Panelboard Metering:

## GENERAL SPECIFICATION 16441 - PANELBOARDS

---

1. Where stated in the Detailed Specifications or shown on the Contract drawings UL listed microprocessor metering unit (MU) shall be installed in the panelboard.
  2. The MU shall have the capability to monitor all the panelboard outgoing and spare circuits including capacity for an additional twenty percent spare circuits.
  3. The MU shall be able to monitor and time stamp at a minimum the following per phase and line values for each circuit:
    - a. Voltage, Current, Power, Power Factor, VAR and Frequency.
    - b. Watt Hour and Var Hour both forward and reverse.
  4. The MU shall be able to auto-detect sensor rating
  5. The MU shall store the energy profile for each circuit in a non-volatile memory for a minimum of one year. The demand interval shall be 15 minutes.
  6. MU communications ports and protocols shall be consistent with those adopted for the site or facility and shall be as stated in the Detailed Specifications or as shown on the Contract Drawings.
- G. Surge Protection:
1. The panelboard shall be provided with surge protective devices complying with General Specification 16281 – Power Filters and Conditioners.
- H. Directories:
1. Each panel shall be provided with a directory. Panel directories shall be typewritten, and shall have designations of each branch circuit. The directory shall be protected by a glass or noncombustible plastic cover.
  2. The Contractor shall maintain in each panel, during the duration of the Contract, a handwritten directory clearly indicating the circuit breakers in service and the number of spares. This directory shall be updated as work progresses, and final, typewritten directories shall be provided at the end of the Contract.
  3. Where execution of the work under this Contract requires certain circuits to be modified, the Contractor shall update the panelboard directories if available to reflect the modifications. Final typewritten directories shall be provided at the end of the Contract.

## GENERAL SPECIFICATION 16441 - PANELBOARDS

---

### 2.03 PAINTING

- A. All metal surfaces of the panelboard enclosures shall be thoroughly cleaned and given one coat of zinc chromate primer. All interior surfaces shall then be given one shop finishing coat of a nitro-cellulose enamel lacquer.
- B. All exterior surfaces shall be given three coats of the same lacquer. The color of finishing coats shall be light gray ANSI No. 61.

### 2.04 SHOP TESTS

- A. Shop tests shall be performed at the panelboard's manufacturer's plant prior to shipment. Shop tests shall demonstrate that the equipment tested conforms to the requirements specified.
- B. Each panelboard shall be given a 60 Hertz, AC, Hi-Pot test, phase to phase and phase to ground, at twice rated voltage plus 1000 volts for one minute, 1500 volts minimum.

## PART 3 EXECUTION

### 3.01 INSTALLATION

- A. Panelboards shall be mounted rigidly and securely to the building structure or to supporting devices which are rigidly and securely supported to the building structure.
- B. Anchor panelboards to satisfy seismic requirements in accordance with the anchorage details.
- C. Panelboards shall be fastened with bolts and expansion shields on concrete or brick, with toggle bolts on hollow masonry units, and with machine screws or welded studs on metal.
- D. Mount all panelboards parallel or perpendicular to walls, such that panelboards are installed in a neat and professional manner.
- E. All wiring shall be neat within the panelboards. Wires shall be run vertically in the wire gutter and then terminate horizontally at a breaker.
- F. The Contractor shall install blanking devices within panelboard spaces so bus bars are not exposed.
- G. Install panelboard nameplates for identification of equipment.
- H. Panelboard circuits shall be installed so to balance the loads on each of the panelboards.

END OF SECTION

NO TEXT ON THIS PAGE

**GENERAL SPECIFICATION 16442 - ELECTRIC CONTROL EQUIPMENT -  
LOW VOLTAGE A.C. MOTORS AND DEVICES**

---

**SECTION 16442  
Electric Control Equipment - Low Voltage A.C. Motors and Devices**

**PART 1 GENERAL**

**1.01 SECTION INCLUDES**

- A. Requirements for providing electric control equipment. Electric control equipment shall be provided in accordance with the requirements specified under this Section, the Detailed Specifications and the Contract Drawings.
- B. The following index of this Section is presented for convenience:

<u>Article</u>	<u>Title</u>	<u>Page</u>
		16442-
PART 1	GENERAL .....	1
1.01	SECTION INCLUDES .....	1
1.02	PAYMENT .....	1
1.03	REFERENCES .....	1
1.04	SUBMITTALS .....	2
1.05	QUALITY ASSURANCE .....	2
1.06	DELIVERY, STORAGE AND HANDLING .....	3
1.07	SPARE PARTS.....	3
PART 2	PRODUCTS.....	4
2.01	SWITCHING DEVICES .....	4
2.02	MAGNETIC MOTOR STARTERS .....	5
2.03	MANUAL MOTOR STARTERS .....	7
2.04	CONTROL STATIONS .....	7
2.05	ENCLOSURES.....	8
PART 3	EXECUTION.....	8
3.01	INSTALLATION .....	8

**1.02 PAYMENT**

- A. Payment for electric control equipment shall be made as provided in the Detailed Specifications.

**1.03 REFERENCES**

- A. Electric control equipment shall comply with the latest applicable provisions and recommendations of the following:
  - 1. NYCEC - Electrical Code of the City of New York.
  - 2. UL Standard No. 98 - Enclosed and Dead-Front Switches
  - 3. UL Standard No. 508 - Industrial Control Equipment

**GENERAL SPECIFICATION 16442 - ELECTRIC CONTROL EQUIPMENT -  
LOW VOLTAGE A.C. MOTORS AND DEVICES**

---

4. UL Standard No 489 - Molded-Case Circuit Breakers, Molded-Case Switches, and Circuit Breaker Enclosures.
5. NEMA Standard KS-1 - Heavy Duty and Dead-Front Enclosed Switches
6. NEMA Standard ICS - Industrial Control and Systems General Requirements
7. NEMA Standard ICS 2 - Industrial Control and Systems, Controllers, Contactors and Overload Relays rated 600V.
8. NEMA Standard ICS 5 - Industrial Control and Systems Control-Circuit and Pilot Devices
9. NEMA Standard ICS 6 - Industrial Control and Systems Enclosures

1.04 SUBMITTALS

- A. Contractor shall submit Shop Drawings and material specifications for the approval of the Engineer. Submittals shall include, but not be limited to:
  1. Manufacturer's catalog cuts, technical information and enclosure details for the electric control equipment.
- B. Operations and Maintenance Manuals shall be submitted in accordance with the Detailed Specifications.

1.05 QUALITY ASSURANCE

- A. Unless otherwise shown on the Contract Drawings, stated in the Detailed Specifications or directed by the standards and codes referenced under this Section, the Contractor shall provide for each low voltage motor or other power device, complete equipment for starting and control.
- B. The starting and control equipment shall be provided with features of protection, current limitation and functioning and be complete with all accessories, appurtenances and supporting structures.
- C. Control equipment shall be UL listed and properly designed with relation to the characteristics of operation of the motor and or device controlled.
- D. Unless otherwise shown on the Contract Drawings or stated in the Detailed Specifications, each motor shall be provided with control equipment consisting of apparatus as follows:
  1. Motors of 1/4 HP or less may, in the absence of other requirements, shall be controlled by a manual motor starter having thermal overload protection at all times.
  2. Motors larger than 1/4 HP shall be controlled by a magnetic motor starter.

**GENERAL SPECIFICATION 16442 - ELECTRIC CONTROL EQUIPMENT -  
LOW VOLTAGE A.C. MOTORS AND DEVICES**

---

3. For wound rotor motors of all horsepower ratings, the primary and secondary shall be controlled by a magnetic motor starter or as stated in the Detailed Specifications.
4. Multiple speed squirrel cage motors, shall be controlled by a magnetic motor starter. The magnetic motor starter shall provide adequate protection of the motor at each speed. A line establishing contactor shall be provided for each motor speed.

E. Each motor shall include overload protection based on latest standards.

1.06 DELIVERY, STORAGE AND HANDLING

- A. Electric control equipment shall be delivered, stored and handled in accordance with the Detailed Specifications and the manufacturer's instructions.

1.07 SPARE PARTS

- A. The Contractor shall furnish and deliver to the Engineer, at that part of the site and at such time as the Engineer may direct, spare parts for the electric control equipment in accordance with the Detailed Specifications.
- B. The spare parts shall be listed in an index and packed in containers suitable for long term storage, bearing labels clearly designating the manufacturer's part number with complete information for use and reordering.
- C. The following spare parts shall be furnished:
  1. One (1) set of contact tips, shunts and coils shall be provided for each 6 or less of each size motor starter.
  2. One (1) auxiliary contact unit or one set of auxiliary contact tips shall be provided for each 6 or less motor starter.
  3. Two (2) sets of arc chutes shall be provided for each type and rating of magnetic contactor.
  4. One (1) timing relay shall be provided of each type installed as part of control equipment installation.
  5. One (1) complete auxiliary relay shall be provided of each type installed as part of control equipment installation.
  6. One (1) control transformer shall be provided of each rating and type installed as part of control equipment installation.
  7. Two (2) complete sets of fuse replacements shall be provided of each rating and type installed as part of control equipment installation.

**GENERAL SPECIFICATION 16442 - ELECTRIC CONTROL EQUIPMENT -  
LOW VOLTAGE A.C. MOTORS AND DEVICES**

---

**PART 2 PRODUCTS**

**2.01 SWITCHING DEVICES**

- A. Switching devices shall be low-voltage devices provided in accordance with the details shown on the Contract Drawings. The switching devices required under this Section shall be the disconnect switch and circuit breaker types.
- B. Switching devices shall be enclosed in NEMA type enclosures in accordance with the requirements specified under this Section.
- C. Switching device line and load terminals shall be provided with shields to prevent accidental contact with them. In addition instrument probe holes shall be provided within the shields to permit investigation by authorized personnel and approved procedures of the state of the terminals.
- D. Disconnect switch type switching devices shall be in accordance with the following:
  - 1. Switches shall be heavy duty type with number of poles, voltage and current ratings as shown on the Contract Drawings.
  - 2. Switches shall be capable of interrupting the full rated current at full rated voltage.
  - 3. Switch enclosure shall be provided with a viewing window through which it shall be permissible to observe the state of the main contacts and surge protective devices when provided.
  - 4. Where specifically shown on the Contract Drawings, disconnect switches shall be complete with fuses, surge protective devices and remote operation.
  - 5. Switches shall be the quick make and quick break type covered with an arc resisting barrier. The switch shall be provided with provision for locking in either open or closed position. The ratings shall be as follows:

Switch Rating in Amperes	MOTOR HORSEPOWER	
	208-240 v.	480 v.
60	Over 5 to 15	Over 5 to 30
100	Over 15 to 25	Over 30 to 60
200	Over 30 to 50	Over 60 to 125
400	Over 50 to 75	Over 125 to 200



**GENERAL SPECIFICATION 16442 - ELECTRIC CONTROL EQUIPMENT -  
LOW VOLTAGE A.C. MOTORS AND DEVICES**

---

- E. Circuit breaker type switching devices shall be in accordance with the following:
1. Circuit breakers shall be the molded case type with number of poles, voltage and current ratings as shown on the Contract Drawings.
  2. Breakers shall be manually or remotely operated thermal magnetic or solid state type, including inverse-time overload and instantaneous short-circuit protection. Contacts shall be nonwelding silver alloy and arc extinction shall be accomplished by means of arc chutes.
  3. Breakers shall have 100 amp frames as a minimum. Overload protection shall be provided on all poles, with trip settings as shown on the Contract Drawings. Breakers with frame sizes 225 amp or larger shall have interchangeable trip units and adjustable magnetic trip elements.
  4. Breakers shall be operated by a toggle-type handle and shall have a quick-make/quick-break over-center switching mechanism that is mechanically trip-free. Automatic tripping of the breaker shall be clearly indicated by the handle position. Breaker enclosure shall be equipped with an external lockable handle with provision for locking in the closed or open position.
  5. Where specifically shown on the Contract Drawings or stated in the Detailed Specifications, breakers shall be provided with electronic trip units. Electronic trip units shall include long time, short time, instantaneous and ground fault settings as minimum.
  6. Where specifically shown on the Contract Drawings or stated in the Detailed Specifications, breakers shall be provided with zone interlocking features, shunt trips, provisions for annunciation of status and auxiliary devices.
- F. Switching devices shall be as manufactured by:
1. Cutler-Hammer, Melville, NY.
  2. General Electric Company, Stamford, CT.
  3. Siemens, Washington, DC
  4. Or approved equal.

2.02 MAGNETIC MOTOR STARTERS

- A. Magnetic motor starters shall be provided complete with fused control power transformer, pilot devices, auxiliary contacts and accessories as shown on the Contract Drawings or stated in the Detailed Specifications.
- B. Magnetic motor starters shall be enclosed in NEMA type enclosures in accordance with the requirements specified under this Section. The starter

**GENERAL SPECIFICATION 16442 - ELECTRIC CONTROL EQUIPMENT -  
LOW VOLTAGE A.C. MOTORS AND DEVICES**

---

shall be combination type. The enclosure shall be equipped with an external operable, pad lockable handle, arranged so that it is impossible to open the door unless the breaker is open.

- C. The starter shall be magnetic coil operated, and shall include a magnetic or solid state motor circuit protector with trip unit range adjustable from 700 to 1300 percent of full load. The combination starters shall be suitable for interrupting 65,000 amps through 480 volts.
- D. Magnetic contactors shall be 3 pole, single throw, 60 Hz with auxiliary contacts for under-voltage protection. Contactors shall be mounted upon steel bases with insulated mountings or upon bases of insulating material. Contactors shall be provided with necessary barriers and arc chutes.
- E. Contactors shall be NEMA rated as follows:

NEMA Size of Contactor	MOTOR HORSEPOWER	
	208-240 v.	480 v.
1	¼ to 7½	¼ to 10
2	over 7½ to 10	over 10 to 25
3	over 15 to 25	over 25 to 50
4	over 30 to 40	over 50 to 100
5	over 50 to 75	over 100 to 200

- F. Contactors in Sizes 1 through 4 shall have double break, silver to silver main contacts. Contactors in Size 5 shall have silver plated tips which close with rolling action and which have self-aligning and self-cleaning features. Auxiliary and interlocking contacts for all sizes shall be of the silver button type. All contact tips shall be easily renewable. Flexible shunts shall be tinned copper braid or tinned extra flexible copper cable.
- G. Overload relays shall be of the ambient temperature compensated bi-metallic or solid state type with interchangeable sensors and manual reset feature. Relay shall include a normally open auxiliary contact for remote alarm purposes. Sensors for overload relays shall be selected to match full load currents of the motors to allow motor operation at maximum safe loads without damage to equipment. Full load current data shall be obtained from nameplates of motors actually installed.

**GENERAL SPECIFICATION 16442 - ELECTRIC CONTROL EQUIPMENT -  
LOW VOLTAGE A.C. MOTORS AND DEVICES**

---

- H. Pilot devices shall be heavy duty type, rated 10 amp continuous. Pushbuttons, selector switches, indicating lights, and other devices shall be located on the starter enclosure. Indicating lights shall be push-to-test, LED, transformer type with 12 volt secondaries.
- I. Relays shall be standard, latching type and pneumatic or solid state time delay type. Relays shall be provided with contacts rated 10 amp with number as required.
- J. Special overload protection shall be provided where definite purpose motors cannot be protected by standard thermal overload relay applications.
- K. Magnetic motor starters shall be as manufactured by:
  - 1. Cutler-Hammer, Melville, NY.
  - 2. General Electric Company, Stamford, CT.
  - 3. Siemens, Washington, DC.
  - 4. Or approved equal.

**2.03 MANUAL MOTOR STARTERS**

- A. Manual motor starters shall be provided complete with pilot devices as shown on the Contract Drawings or stated in the Detailed Specifications.
- B. Manual motor starters shall be enclosed in NEMA type enclosures in accordance with the requirements specified under this Section.
- C. Manual motor starters shall be toggle operated, NEMA horsepower rated, single phase type with thermal overload protection unless shown otherwise on the Contract Drawings or stated in the Detailed Specifications. Pilot devices when required shall be in accordance with the requirements specified under this Section.
- D. Where shown on the Contract Drawings, manual motor starters shall be low-voltage, three phase type without overload protection for use as manual starting disconnect switches. The switches shall be NEMA size 0 or 1 horsepower rated, as required for the application intended.
- E. Manual motor starters shall be as manufactured by:
  - 1. Cutler-Hammer, Melville, NY.
  - 2. General Electric Company, Stamford, CT.
  - 3. Siemens, Washington, DC.
  - 4. Or approved equal.

**2.04 CONTROL STATIONS**

- A. Control Stations shall be provided in accordance with the details on the Contract Drawings.

**GENERAL SPECIFICATION 16442 - ELECTRIC CONTROL EQUIPMENT -  
LOW VOLTAGE A.C. MOTORS AND DEVICES**

---

- B. Control Stations shall be enclosed in NEMA type enclosures in accordance with the requirements specified under this Section.
- C. Control stations shall be industrial, heavy duty, oil tight construction with clearly marked legend plates. Stations shall have operating devices as shown on the Contract Drawings.
- D. Contact ratings shall be 10 amp minimum. All indicating lights shall be LED, transformer type, lens color shall be as shown on the Contract Drawings.
- E. Control stations shall be as manufactured by:
  - 1. Cutler-Hammer, Melville, NY.
  - 2. General Electric Company, Stamford, CT.
  - 3. Siemens, Washington, DC.
  - 4. Or approved equal.

2.05 ENCLOSURES

- A. Enclosures shall be provided for the electric control equipment. Enclosures located indoors in dry, dusty areas shall be gasketed and shall be constructed of 14 gauge sheet steel. Cabinet type enclosures shall include hinged and gasketed front doors.
- B. Enclosures shall be provided in accordance with NEMA requirements as required for the area classifications indicated on the Contract Drawings.
- C. For dry, dusty locations, enclosures shall meet NEMA 12 requirements. For wet and corrosive locations, enclosures shall meet NEMA 4X requirements. NEMA 4X enclosures shall be fabricated from 316 stainless steel.
- D. Unless specifically noted otherwise on the Contract Drawings or stated in the Detailed Specifications, enclosures within hazardous locations shall meet Class 1, Division 1, Group D requirements. Hazardous enclosures shall be fabricated from cast metal.

PART 3 EXECUTION

3.01 INSTALLATION

- A. Equipment shall be mounted so that sufficient access and working space is provided for ready and safe operation and maintenance.
- B. Equipment shall be securely fasten to walls or other surfaces on which they are mounted. Independent supports shall be provided where no wall or other surface exists.
- C. Electric control equipment shall be installed in conformance with the New York City Electrical Code of New York..

END OF SECTION

**SECTION 16491**

**Fuses**

**PART 1 GENERAL**

**1.01 SECTION INCLUDES**

- A. Requirements for providing fuses. Fuses shall be provided in accordance with the requirements specified under this Section, the Detailed Specifications and the Contract Drawings.
- B. The fuses required under this Section shall be low-voltage and medium-voltage and classes. The fuses of each class shall be suitable for use with power circuits.
- C. The following index of this Section is presented for convenience:

<u>Article</u>	<u>Title</u>	<u>Page</u>
		16491-
PART 1	GENERAL .....	1
1.01	SECTION INCLUDES .....	1
1.02	PAYMENT .....	1
1.03	REFERENCES .....	1
1.04	SUBMITTALS .....	2
1.05	QUALITY ASSURANCE .....	2
1.06	DELIVERY, STORAGE AND HANDLING .....	2
1.07	SPARE PARTS .....	2
PART 2	PRODUCTS .....	3
2.01	MANUFACTURERS .....	3
2.02	FUSES .....	3
PART 3	EXECUTION .....	4
3.01	INSTALLATION .....	4

**1.02 PAYMENT**

- A. Payment for fuses shall be made as provided for in the Detailed Specifications.

**1.03 REFERENCES**

- A. Fuses shall comply with the latest applicable provisions and recommendations of the following:

- 1. UL 248 - Low-voltage Fuses.
- 2. IEEE C37.40 - Service Conditions and Definitions for High-Voltage Fuses, Distribution Enclosed Single-Pole Air Switches,

## GENERAL SPECIFICATION 16491 - FUSES

---

Fuse Disconnecting Switches and Accessories.

3. IEEE C37.41 - Design Tests for High-Voltage Fuses, Fuse Disconnecting Switches and Accessories.
4. IEEE C37.46 - Specification for High-Voltage Expulsion and Current-Limiting Power Class Fuses and Fuse Disconnecting Switches.

### 1.04 SUBMITTALS

- A. Contractor shall submit Shop Drawings and material specifications for the approval of the Engineer. Submittals shall include, but not be limited to:
  1. Manufacturer's catalog cuts for the fuses proposed for use with specifications and other data required to demonstrate compliance with the specified requirements.
  2. Time - current curves for the fuses proposed for use.

### 1.05 QUALITY ASSURANCE

- A. Low-voltage fuses shall be designed, built and tested in accordance with UL 248. Low-voltage fuses shall be UL listed by class.
- B. Medium-voltage fuses shall be designed, built and tested in accordance with IEEE C37.40, 41 and 46.

### 1.06 DELIVERY, STORAGE AND HANDLING

- A. Fuses shall be delivered, stored and handled in accordance with the Detailed Specifications and the manufacturer's recommendations.

### 1.07 SPARE PARTS

- A. The Contractor shall furnish and deliver to the Engineer, at that part of the site and at such time as the Engineer may direct, spare fuses in accordance with the Detailed Specifications.
- B. The spare fuses shall be listed in an index and packed in containers suitable for long term storage, bearing labels clearly designating the manufacturer's part number with complete information for use and reordering.
- C. Spare fuses shall include at a minimum the following:
  1. Low-voltage fuses, 10 percent of each rating used. Minimum of three of each rating.

2. Medium-voltage fuses, 10 percent of each rating used. Minimum of three of each rating.

**PART 2 PRODUCTS**

**2.01 MANUFACTURERS**

- A. Low-voltage fuses shall be as manufactured by:
  1. Eaton Bussmann, Ellisville, MO
  2. Mersen Ferraz Shawmut, San Francisco, CA.
  3. Littlefuse, Chicago, IL
  4. Or approved equal.
- B. Medium-voltage fuses shall be as manufactured by:
  1. Eaton Bussmann, Ellisville, MO
  2. Mersen Ferraz Shawmut, San Francisco, CA.
  3. S&C Electric, Chicago, IL.
  4. Or approved equal.

**2.02 FUSES**

- A. General:
  1. Fuses shall be provided with a voltage class suitable for the intended service. Fuses shall be compatible with the system operating voltage shown on the Contract Drawings.
  2. Low-voltage fuse ampere ratings and medium voltage fuse NEMA E and R ratings shall be as shown on the Contract Drawings.
- B. Low-voltage Fuses:
  1. Low-voltage fuses shall be current limiting, time delay type. Low-voltage fuses shall have a 200,000 RMS symmetrical ampere interrupting rating.
  2. Low-voltage fuses with current ratings up to 600 ampere shall be UL class RK1.
  3. Low-voltage fuses with current ratings greater than 600 ampere shall be UL class L.
- C. Medium-voltage Fuses:
  1. Medium-voltage fuses shall be current limiting type, unless stated in the Detailed Specifications to be boric acid expulsion type.

## GENERAL SPECIFICATION 16491 - FUSES

---

2. Current limiting type medium-voltage fuses shall have a 50,000 RMS symmetrical ampere interrupting rating. When boric acid expulsion type medium-voltage fuses are used, interrupting ratings shall be as shown on the Contract Drawings.
3. Medium-voltage fuses when used with interrupter switches shall be E rated. When used with motor starters for motor protection, medium-voltage fuses shall be R rated.
4. Medium-voltage fuses shall be provided with a blown fuse indicator to signal operation of the fuse element.

### PART 3 EXECUTION

#### 3.01 INSTALLATION

- A. Fuses shall be installed within equipment in accordance with the manufacturer's recommendations.

END OF SECTION



**GENERAL SPECIFICATION 16511 - LIGHTING FIXTURES AND DEVICES**

---

**SECTION 16511  
Lighting Fixtures and Devices**

**PART 1 GENERAL**

**1.01 SECTION INCLUDES**

- A. Requirements for providing lighting fixtures (luminaires) and devices. Luminaires and devices shall be provided in accordance with the requirements specified under this Section, the Detailed Specifications and the Contract Drawings.
- B. The lighting system shall be complete and include all equipment, devices and accessories as required for the installation of the luminaires and devices.
- C. The following index of this Section is presented for convenience:

<u>Article</u>	<u>Title</u>	<u>Page</u>
		16511-
PART 1	GENERAL .....	1
1.01	SECTION INCLUDES .....	1
1.02	RELATED SECTIONS .....	1
1.03	PAYMENT .....	2
1.04	REFERENCES .....	2
1.05	SUBMITTALS .....	3
1.06	QUALITY ASSURANCE .....	4
1.07	DELIVERY, STORAGE AND HANDLING .....	5
1.08	SPARE PARTS.....	5
PART 2	PRODUCTS.....	6
2.01	Luminaires .....	6
2.02	LAMPS .....	6
2.03	Drivers and BALLASTS.....	7
2.04	EMERGENCY INVERTER SYSTEMS.....	9
2.05	LIGHTING CONTACTOR PANELS.....	10
2.06	RECEPTACLES AND SWITCHES .....	10
PART 3	EXECUTION.....	13
3.01	INSTALLATION OF LUMINAIRES.....	13
3.02	INSTALLATION OF DEVICES .....	14
3.03	FIELD TESTS .....	15
3.04	MANUFACTURER 'S FIELD SERVICES.....	15
3.05	CLEANING OF LUMINAIRES .....	15

**1.02 RELATED SECTIONS**

- A. General Specification 01411 - Envision Requirements
- B. General Specification 16061 - Grounding

## **GENERAL SPECIFICATION 16511 - LIGHTING FIXTURES AND DEVICES**

---

C. General Specification 16076 - Labeling and Identification

D. General Specification 16131 - Electric Conduit System

### 1.03 PAYMENT

A. Payment for lighting fixtures and devices shall be made as provided for in the Detailed Specifications.

### 1.04 REFERENCES

A. Luminaires and devices shall comply with the latest applicable provisions and recommendations of the following even if not specifically listed in this Section:

1. ANSI C78.377 - Specifications for the Chromaticity of Solid State Lighting (SSL) Products
2. DLC PR - Design Lights Consortium Premium Technical Requirements
3. EISA 2007 - Energy Independence and Security Act of 2007
4. IES LM-79 - Approved Method: Electrical and Photometric Measurements of Solid State Lighting Products
5. IES LM-80 - Approved Method: Measuring Luminous Flux and Color Maintenance of LED Packages, Arrays and Modules
6. IES TM-21 - Technical Memorandum on Projecting Long Term Lumen Maintenance of LED Light Sources
7. NEMA SSL-1 - Electronic Drivers for LED Devices, Arrays, or Systems.
8. NYCEC - New York City Electrical Code.
9. NYCECC - New York City Energy Conservation Code
10. UL 20 - General Use Snap Switches.
11. UL 844 - Electric Lighting Fixtures for Use in Hazardous Locations.
12. UL 894 - Switches for Use in Hazardous Locations.

## **GENERAL SPECIFICATION 16511 - LIGHTING FIXTURES AND DEVICES**

---

- 13. UL 924 - Emergency Lighting and Power Equipment.
- 14. UL 935 - Fluorescent Lamp Ballasts.
- 15. UL 1010 - Electrical Receptacle - Plug Combinations for Use in Hazardous Locations.
- 16. UL 1029 - High Intensity Discharge Lamp Ballasts.
- 17. UL 1570 - Fluorescent Lighting Fixtures.
- 18. UL 1572 - High Intensity Discharge Lighting Fixtures.
- 19. UL 1598 - Luminaires
- 20. UL 8750 - Light Emitting Diode (LED) Equipment for Use in Lighting Products.
- 21. CBM - Certified Ballast Manufacturers, CBM.

### 1.05 SUBMITTALS

- A. Contractor shall submit Shop Drawings and material specifications for the approval of the Engineer. Submittals shall include, but not be limited to:
  - 1. A list of proposed manufacturers with the products they produce proposed for the contract.
  - 2. Manufacturer's catalog cuts and drawings showing all technical information, and construction details for luminaires, including dimensions, type of wiring, weight, size, installation methods, provisions for re-lamping or replacing luminaires from the ground, test information criteria and rated life in hours with corresponding standard.
  - 3. Photometric data, developed for each fixture type.
  - 4. Lamp type and technical information.
  - 5. Ballast type and technical information.
  - 6. Driver type for LED luminaires and technical information including input voltage, power factor, Crest Factor and THD.
  - 7. Scaled Shop drawings showing the locations of all fixtures and devices. The Drawings shall include the proposed routing of the branch circuits.
- B. Reports:
  - 1. Field test reports shall be submitted.
  - 2. Manufacturer's site visit report shall be submitted.
- C. Operations and Maintenance Manuals shall be submitted in accordance with the Detailed Specifications.

## **GENERAL SPECIFICATION 16511 - LIGHTING FIXTURES AND DEVICES**

---

- D. The Contractor shall report information pertaining to the sustainable procurement, regional sourcing, and recycled content of new materials to be procured during the Work, in accordance with General Requirements 01411 – Envision Requirements.

### 1.06 QUALITY ASSURANCE

#### A. General:

1. Luminaires shall be UL listed, approved for use in the City of New York and comply with NYCECC. The luminaire types are noted within the fixture schedule. The descriptions and catalog numbers serve to establish the quality, appearance and performance of the specified luminaires.
2. Luminaires and controls shall be as manufactured by the same manufacturer.
3. Luminaires over the range of operating voltage and temperature shall comply with the following:
  - a. Minimum power factor of 0.95
  - b. THD for both current and voltage of less than 10%
4. Luminaires shall have integral UL Listed Class 2 drivers and ballasts.
5. Luminaires shall have integral surge protective devices (SPD) to protect the luminaire from common mode transient peak voltages and transient peak currents
6. Luminaires shall comply with DLC PR.
7. Luminaires utilizing incandescent sources are not permitted.
8. Luminaires shall utilize electronic or solid state drivers or ballasts where applicable.
9. All luminaires shall be the products of lighting equipment manufacturers who have previously demonstrated, by performance and reputation, the ability to manufacture products of the quality specified. Such manufacturers must maintain an organization and manufacturing facility capable of actually manufacturing the specified luminaires. For the purpose of inspection, Contractor shall assure the Engineer, free and easy access to the manufacturing facilities and inventories of any manufacturer whose equipment the Contractor proposes to supply.
10. The Contractor shall be responsible to assure that the exact inscription for exit and stairway signs required by local code is checked against that specified, prior to providing same. The Engineer shall be advised of any changes required to conform to local codes before such changes are effected.
11. The Contractor shall be responsible for reviewing all Contract drawings and coordinating with all trades the installation of luminaires and devices. Luminaire and device finishes and construction shall be compatible with the

## **GENERAL SPECIFICATION 16511 - LIGHTING FIXTURES AND DEVICES**

---

approved wall and ceiling types which shall be determined by the Contractor's review of all Contract drawings.

12. All luminaires shall be of the highest quality material and construction for their respective types.
13. Lamps for all luminaires shall be in accordance with EISA 2007.
14. Luminaires shall be suitable for connection to concealed or exposed conduit runs as required in each particular location and shall be of sizes suitable for lamp sizes indicated on the Contract Drawings.
15. Fittings and other materials for special luminaires not definitely shown or specified shall be of approved material, make and quality and shall have a finish that will harmonize with other parts of the luminaires. Where suitable standard materials are not available such parts of the luminaires shall be specially manufactured.

**B. Field Testing:**

1. Luminaires shall be field tested. The field testing shall be performed in accordance with the requirements specified under this Section.
2. Retain the services of the emergency inverter system manufacturer for field services. Field service shall be in accordance with the requirements specified under this Section.

**1.07 DELIVERY, STORAGE AND HANDLING**

- A.** Luminaires and devices shall be delivered, stored and handled in accordance with the Detailed Specifications and the manufacturer's instructions.

**1.08 SPARE PARTS**

- A.** The Contractor shall furnish and deliver to the Engineer, at that part of the site and at such time as the Engineer may direct, spare parts for luminaires and devices in accordance with the Detailed Specifications.
- B.** The spare parts shall be listed in an index and packed in containers suitable for long term storage, bearing labels clearly designating the manufacturer's part number with complete information for use and reordering.
- C.** The following spare parts shall be furnished:
1. 10 percent lamps, lamp module or array shall be provided of each wattage of each type of lamp, lamp module or array but not less than the requirement for two luminaires.
  2. Where the lamp, lamp module or array is an integral part of the luminaire and the lamp, lamp module or array is not normally replaceable provide spare luminaires instead.

## **GENERAL SPECIFICATION 16511 - LIGHTING FIXTURES AND DEVICES**

---

3. 5 percent ballasts or drivers shall be provided of each type of type of ballast or driver, but not less than two.
4. 5 percent total fuses for each luminaire type and size but not less than one set for each size.

### **PART 2 PRODUCTS**

#### **2.01 LUMINAIRES**

- A. A luminaire shall be provided for each luminaire symbol shown on the Contract Drawings. Luminaires shall be provided in accordance with the luminaire schedule shown in the Detailed Specifications.
- B. Luminaires shall be provided with all necessary hangers, supports, conduit adaptors, reducers, hooks, brackets and other support hardware. All hardware shall have a protective, non-corrosive finish.
- C. Recessed luminaires shall be provided with trim moldings and frames suitable for the types of ceilings.
- D. Pendent mounted luminaires shall be suspended by means of an enclosed and gasketed cushion type hanger. The hanger shall be suitable to be mounted directly to the luminaire outlet box and shall provide a minimum of 8 degrees swing from the vertical. Stems shall be threaded rigid metal conduit, 1/2 inch minimum size. In corrosive areas stems shall be PVC coated.
- E. Where luminaires are subjected to moisture, or assembled of dissimilar metals, gaskets of approved material and thickness shall be provided.
- F. Explosion-proof type luminaires shall comply with the requirements of the NYCEC for the hazardous locations indicated on the Contract Drawings.
- G. Luminaires shall be completely wired except where they will be directly connected to branch circuit wiring. The conductors shall be not less than No. 12 gauge, stranded, with approved heat resistant covering.
- H. Mounting heights of all luminaires shall be as shown on the Contract Drawings. For special types, the height shall be determined at the time of installation.

#### **2.02 LAMPS**

- A. Lamps in association with their ballasts or drivers shall have voltage ratings suitable for the voltages shown on the Contract Drawings.
- B. The color temperature of lamps shall be such that the installed luminaire color temperature is as listed in the Detailed Specifications or shown on the Contract Drawings.
- C. LED lamps shall be in accordance with the following:
  - a. Comply with UL 8750

## **GENERAL SPECIFICATION 16511 - LIGHTING FIXTURES AND DEVICES**

---

- b. CRI of not less than 85
  - c. Minimum efficacy of 140 lumens/watt
  - d. Lamp L80 life of not less than 100,000 hours at 25 degrees C
  - e. Maximum junction temperature of 150 degrees C
  - f. Binning per ANSI C78.377 at 85 degrees C
  - g. Very low thermal resistance to permit optimum heat transfer from the junction to the operating ambient.
- D. Fluorescent lamps shall be 32 watt T8 energy efficient rapid start type for use with electronic ballast. Lamps shall be suitable for operation indoors and outdoors.
- E. High pressure sodium lamps shall be clear with medium or mogul base and wattage as indicated in the luminaire schedule.
- F. Metal halide lamps shall be standard-line phosphor coated with wattage as indicated in the fixture schedule.
- G. Lamps shall be as manufactured by:
- 1. Cree, Durham, NC.
  - 2. Nichia America Corporation, Wixom, WI.
  - 3. GE Lighting, Cleveland, OH.
  - 4. Osram Sylvania, Wilmington, MA.
  - 5. Or approved equal.

### 2.03 DRIVERS AND BALLASTS

- A. General:
- 1. Ballasts and Drivers shall be matched for proper operation of lamps and shall meet the requirements for luminaire light output, reliable starting and operation.
  - 2. Ballasts and Drivers shall have dimming capabilities and the lamps shall be corresponding suitable for dimming. Dimming requirements shall be listed in the Detailed Specifications or as shown on the Contract Drawings.
  - 3. Ballasts shall be UL listed and certified by approved Nationally Recognized Testing Laboratories (NRTL). Testing Laboratories and shall conform to CBM.
  - 4. Drivers and Ballasts shall be as manufactured by:
    - a. Osram Sylvania, Wilmington, MA
    - b. Universal Lighting Technologies Inc, Nashville, TN
    - c. eldoLED, Conyers, GA.

## **GENERAL SPECIFICATION 16511 - LIGHTING FIXTURES AND DEVICES**

---

d. Advance Transformer, Rosemont, IL.

e. Or approved equal.

### **B. LED Drivers**

1. LED drivers shall be matched to their lamps such that the luminaire supply voltage and its likely site variations shall produce a level of performance indicated in the Detailed Specifications and as shown on the Contract Drawings
2. LED Drivers in conjunction with the respective luminaire construction shall achieve
  - a. Specified lumen output with variation from specified voltage of plus or minus 10%.
  - b. Rated life of not less than 100,000 hours.
  - c. THD of less than 10% across the specified voltage range and full power.
  - d. Power factor of not less than 95% and over the full range if dimming specified.
  - e. Consistent performance over the range of temperatures expected at the installation location either indoors or outdoors.
  - f. Cooling shall be achieved with static arrangements. Active cooling, thermal foldback or thermal sensing to achieve temperature control are not permitted.
3. Electrical connections between LED Drivers and all components of the luminaire shall be polarized and color coded to permit trouble free connection and reconnection. A connection diagram shall be imprinted on the Driver or the internal of the luminaire.

### **C. Fluorescent Ballasts:**

1. Fluorescent ballasts shall be high power factor, energy efficient type. Ballasts shall be Class P protected with a Class A sound rating. Ballast used with fixtures outdoors shall be cold weather type.
2. Ballasts for use with 32 watt T8 lamps shall be electronic type, with total harmonic distortion less than 10 percent total. The ballast factor shall be 0.85 or greater with total of less than 61 watts input.
3. Controllable electronic ballasts shall continuously dim between 20 and 100 percent of light output. The dimming circuitry shall be UL Class 2 fully isolated and shall provide a 0-10 VDC control signal between ballast and control element.

### **D. High Intensity Discharge Ballasts:**



## **GENERAL SPECIFICATION 16511 - LIGHTING FIXTURES AND DEVICES**

---

1. Ballasts shall have a power factor of not less than 90 percent for 70 watt lamps and above.
2. Ballasts shall be (lag-type) magnetic regulator type for lamps 70 to 400 watts. High power factor reactor ballasts shall be provided for lamps below 70 watts.
3. In non-air conditioned spaces, ballasts shall be rated for operation in 40 degrees C temperature environment. Ballasts shall be capable of starting lamps with a lamp wall temperature of 0 degrees C or lower.
4. Ballasts, including the starter aid, shall protect itself against normal lamp failure modes and shall be capable of operation with the lamp in an open or short circuit condition for six months without accelerated loss of ballast life.
5. Ballast primary current during starting shall not exceed normal operating current.
6. Ballasts shall be capable of sustaining lamp operation with a line voltage dip or sag of 50 percent for up to 4 seconds when operating a nominal voltage lamp, with nominal line voltage applied to the ballast primary, as defined in ANSI 82.6.
7. The line power factor of the lamp/ballast system shall not drop below 90 percent for plus or minus 10 percent line voltage variations at any lamp voltage, from nominal through rated end-of-life lamp voltage, as described in ANSI 82.6.

### **2.04 EMERGENCY INVERTER SYSTEMS**

- A. Emergency inverter systems shall be provided for operation of exit signs and emergency luminaires. Each system shall be provided with normal input and inverter output voltages, capacity and number of output circuits as shown on the Contract Drawings. The output circuits shall be any combination of up to ten security and emergency circuits.
- B. Each system shall consist of an input line circuit breaker, sine wave inverter and battery section complete with the manufacturer's standard monitoring and control functions housed in a vented free standing enclosure. The enclosure shall have identifying nameplates in accordance with the requirements of General Specification 16076 - Labeling and Identification. Each system shall be UL 924 listed.
- C. The inverter shall be electronic solid state type suitable for operating all type loads. The batteries shall be sealed, maintenance-free lead calcium and shall include a recharge charger and transfer relay.
- D. Each system shall operate on AC single phase normal input power supplying both the security circuits and the battery charger. If the normal power is lost, the inverter shall provide, AC single phase emergency power to operate for up to 90 minutes both the security and the emergency circuits.

## **GENERAL SPECIFICATION 16511 - LIGHTING FIXTURES AND DEVICES**

---

- E. The system output shall automatically switch to battery power within 750 milliseconds upon an outage of the normal input and when restored transfer back after time delay.
- F. The emergency inverter systems shall be as manufactured by:
  - 1. Vertiv-Emerson Network Power, Houston, Texas.
  - 2. Emergi-Lite, West Yorkshire, United Kingdom.
  - 3. Or approved equal.

### **2.05 LIGHTING CONTACTOR PANELS**

- A. Lighting contactor panels shall be provided for the control of luminaires where specifically indicated on the Contract Drawings. The panel control and devices shall be arranged for proper operation in accordance with the control schematics shown on the Contract Drawings.
- B. The panel enclosures shall be steel, single door type. Enclosures shall be NEMA 12 for dry, indoor areas and NEMA 4X for corrosive areas. Each enclosure shall be equipped with a control fuse with mounting block and 300 volt screw type terminal blocks.
- C. Contactors shall be mechanically held type suitable for 120 volt operation and switching ballast type lighting. Contactor voltage, ampere, number of poles and quantities within each panel shall be as shown on the Contract Drawings.
- D. Where indicated on the Contract Drawings, the lighting contactor panels shall be provided with selector switches and control relays. Selector switches and control relays shall be heavy duty industrial type.

### **2.06 RECEPTACLES AND SWITCHES**

- A. General:
  - 1. Receptacles and switches shall be provided in accordance with the Detailed Specification and as shown on the Contract Drawings. The receptacles and switches shall be complete and shall include all accessories for proper installation.
  - 2. Outlet boxes for receptacles and switches shall be in accordance with General Specification 16131 - Electric Conduit System.
  - 3. Unless specifically shown otherwise or stated in the Detailed Specifications explosion proof devices in hazardous locations shall comply with the requirements of the NYCEC for Class I, Division 1, Group D locations.
- B. Receptacles:
  - 1. Receptacles shall be duplex grounding type, two pole, three wire, 125 volt AC, 15 ampere. Where shown on the Contract Drawings, other special receptacles

## **GENERAL SPECIFICATION 16511 - LIGHTING FIXTURES AND DEVICES**

---

- with number of poles, voltage and current rating shall be provided. Matching plugs shall be provided for each special receptacle.
2. Receptacles for indoor dry, dusty locations shall be heavy duty, straight blade type, with reinforced polyester base and impact resistant nylon face.
  3. Receptacles for wet and corrosive locations shall be marine duty, straight blade type, with heat resistant melamine body. Special receptacles in wet and corrosive locations shall be Type 316 stainless steel.
  4. Receptacles for hazardous locations shall be factory sealed and shall be in accordance with the following:
    - a. Explosion-proof type receptacles shall be of the delayed action type requiring the turning of a plug shell on withdrawal to allow time for extinction of arcs.
    - b. Surface mounted explosion-proof receptacles shall be provided with cast iron or cast aluminum angle type covers with hinged flaps.
    - c. Flush mounted explosion-proof receptacles shall be provided with brass, chromium plated, flush plates with double hinged flaps.
    - d. Plugs shall be provided where required for each type of explosion-proof receptacle. Plugs shall be of explosion-proof construction, and shall have steel bodies with corrosion resistant finish. Plugs shall be fitted with aluminum alloy cable clamps and chloroprene cable bushings.
  5. Receptacles for installation in floors shall be in accordance with the following:
    - a. Floor receptacles shall comprise a watertight unit consisting of a cast iron box with an adjustable top, permitting permanent angular and vertical adjustment, brass cover plate and 3/4 inch brass floor extension. The extension shall be of an approved height and shall be surmounted with a brass head arranged for a duplex receptacle. Exposed metal parts shall be finished to match adjacent metal finish.
    - b. For low voltage signal and telephone work, floor outlets shall be equal to those specified above for floor installation, except that the interiors shall be designed for cable extension as approved.
  6. Fan or clock outlets shall be single receptacles with molded composition or bakelite bodies. Rating shall be 15 amperes, 125 volts. Fan outlets shall be furnished with stud supports. Clock outlets shall be of the recessed type and shall be furnished with yokes for clock support.
  7. 480 volt receptacles in non-hazardous areas shall be a mechanically interlocked type with circuit breaker disconnect. The disconnect cannot be closed until the plug is fully inserted and the plug cannot be withdrawn or inserted unless the

## **GENERAL SPECIFICATION 16511 - LIGHTING FIXTURES AND DEVICES**

---

switch is open. The receptacle enclosure shall be copper - free aluminum with stainless steel parts.

8. Receptacles shall be as manufactured by:
  - a. Hubbel Incorporated, Shelton, CT.
  - b. Arrow-Hart Incorporated, Chicago, IL.
  - c. Or approved equal.
9. Hazardous located receptacles and 480 volt receptacles shall be as manufactured by:
  - a. Crouse-Hinds Company, Syracuse, NY.
  - b. Appleton Electric Company, Rosemont, IL.
  - c. Or approved equal.

### **C. Switches:**

1. Switches shall be industrial-heavy duty, AC toggle quiet type. Switches shall be rated 120/277 volt, 20 ampere. Poles and switching shall be as shown on the Contract Drawings.
2. Switches for hazardous locations shall be factory sealed tumbler type. The switch body and cover shall be cast gray iron alloy or cast malleable iron with zinc electroplate finish.
3. Switches shall be as manufactured by:
  - a. Hubbel Incorporated, Shelton, CT.
  - b. Arrow-Hart Incorporated, Chicago, IL.
  - c. Or approved equal.
4. Hazardous located receptacles shall be as manufactured by:
  - a. Crouse-Hinds Company, Syracuse, NY.
  - b. Appleton Electric Company, Rosemont, IL.
  - c. Or approved equal.

### **D. Plates and Covers:**

1. Stainless steel plates shall be furnished for devices in indoor dry, dusty locations. They shall have beveled edges and shall be made of Type 302/304, stainless steel.
2. Plates shall have satin finish. Attachment screws shall have matching head finish.

## **GENERAL SPECIFICATION 16511 - LIGHTING FIXTURES AND DEVICES**

---

3. For wet and corrosive locations neoprene gasketed covers shall be used. Covers shall be galvanized ferrous or cast ferrous metal. Covers shall be PVC-coated in corrosive locations. Covers shall be equipped with gasketed spring doors for receptacles and an external operating mechanism for switches.
4. Plates shall be as manufactured by:
  - a. Hubbel Incorporated, Shelton, CT.
  - b. Arrow-Hart Incorporated, Chicago, IL.
  - c. Or approved equal.
5. Covers shall be as manufactured by:
  - a. Crouse-Hinds Company, Syracuse, NY.
  - b. Appleton Electric Company, Rosemont, IL.
  - c. Or approved equal.

### **PART 3 EXECUTION**

#### **3.01 INSTALLATION OF LUMINAIRES**

- A. Luminaires shall be installed at locations shown on the Contract Drawings. Luminaire locations shall be adjusted where necessary to clear conflicts and obstructions.
- B. All luminaires shall be installed complete with all hardware, and supporting devices necessary to make a safe complete and fully operative installation. The Contractor shall obtain from the manufacturer for each luminaire, diagrams, illustrations and other installation instructions. The Contractor shall install in strict conformance with such instructions and the requirements of NYEC.
- C. Recessed fixtures shall be installed in suspended ceiling openings in conformance with manufacturer's recommendations and to suit the architectural details of the area involved. Independent supports from structural members of the building shall be provided. Unless otherwise shown on the Contract Drawings or stated in the Detailed Specifications, every fluorescent luminaire shall have at least two supports, and continuous lines of fluorescent luminaire shall be supported at 4 foot intervals.
- D. Pendant mounted fixtures shall be installed with pendants 1/2 inch for stems up to 5 feet and 3/4 inch for longer lengths.
- E. All pendant stem hangers shall be furnished with suitable aligner canopies or outlet box covers so that the luminaires hang vertical to the finished floor irrespective of the angle of the surface from which they are suspended. When luminaires or hanger canopies are mounted flush to the ceiling or wall, and where raceways and outlet boxes serving the luminaires are surface mounted to the ceiling or wall, finishing

## **GENERAL SPECIFICATION 16511 - LIGHTING FIXTURES AND DEVICES**

---

rings shall be provided to conceal the outlet box. All visible hanging devices and appurtenances shall have the same finish as the luminaire.

- F. Reflectors, lenses, diffusers, louvers and decorative elements of luminaires shall not be installed until completion of plastering, ceiling tile work, painting, and general clean-up in the area.

### 3.02 INSTALLATION OF DEVICES

#### A. Emergency Inverter System:

1. Equipment shall be installed in accordance with manufacturer's instructions and recommendations.
2. Equipment shall be installed on concrete pads at locations indicated on the Contract Drawings so that sufficient access and working space is provided for ready and safe operation and maintenance.
3. Install system nameplates for identification of equipment.

#### B. Lighting Contactor Panels:

1. Panels shall be mounted rigidly and securely to the building structure or to supporting devices which are rigidly and securely supported to the building structure.
2. Panels shall be fastened with bolts and expansion shields on concrete or brick, with toggle bolts on hollow masonry units and with machine screws or welded studs on metal.
3. All panels shall be mounted parallel or perpendicular to walls, such that panels are installed in a neat and professional manner.

#### C. Receptacles and Switches:

1. Receptacles and switches shall be installed within outlet boxes at locations indicated on the Contract Drawings and in accordance with code requirements.
2. Receptacles shall be mounted 2 feet above the finished floor, except in hazardous locations where receptacles shall be mounted 4 feet-6 inches above the finished floor.
3. Switches shall be mounted 4 feet 6 inches above the finished floor.
4. Where devices are grouped they shall be mounted under a common plate. Where directed or where space conditions limit gang mounting, tandem or tandem gang arrangement shall be provided.
5. Where four or more switches controlling fixtures that are not visible from the switch location are grouped, the switch plate shall be engraved and filled with colored material or otherwise suitably marked to designate the control of each switch.

## **GENERAL SPECIFICATION 16511 - LIGHTING FIXTURES AND DEVICES**

---

### 3.03 FIELD TESTS

- A. After installation, the completed lighting system and receptacle devices shall be field tested for operation and conformance. The field tests shall be witnessed by the Engineer and certified by the Contractor. The Contractor shall provide testing consisting of the following:
  - 1. Wiring continuity test shall be performed.
  - 2. Branch circuit load balance test shall be performed.
  - 3. Fixture and control operation test shall be performed.
  - 4. Emergency inverter system operation and functionality test shall be performed.
  - 5. Receptacle polarity and grounding.
- B. The Contractor shall provide a field test report. The report shall identify the test performed and the results obtained.

### 3.04 MANUFACTURER'S FIELD SERVICES

- A. A qualified manufacturer's service representative shall assist in the installation of the emergency inverter system, check the installation before it is placed into operation, assist in the performance of field tests, observe the initial operation and train the plant operations and maintenance staff in the care, operation and maintenance of the system.
- B. The Contractor shall provide equipment start-up services and training in accordance with the Detailed Specifications.
- C. The Contractor shall provide a field report from the manufacturer's representative for each visit to the site. The report shall include complete information on time, schedule, tasks performed, persons contacted, problems corrected, tests results, training instruction and all other pertinent information.
- D. The service representative shall sign in with the Engineer on each day they are at the site.

### 3.05 CLEANING OF LUMINAIRES

- A. Luminaires shall be cleaned inside and out to remove construction dust prior to substantial completion.
- B. Fixtures shall be relamped prior to substantial completion.

END OF SECTION

**GENERAL SPECIFICATION 16511 - LIGHTING FIXTURES AND DEVICES**

NO TEXT ON THIS PAGE



**GENERAL SPECIFICATION 16521 – OUTDOOR LIGHTING**

---

**SECTION 16521  
Outdoor Lighting**

**PART 1 GENERAL**

**1.01 SECTION INCLUDES**

- A. Requirements for providing outdoor lighting. Outdoor lighting shall be provided in accordance with the requirements under this section, the Detailed Specifications and the Contract Drawings.
- B. The outdoor lighting system shall be complete and include all luminaires, poles, pole bases, reinforced concrete foundations and accessories as required for the installation of the outdoor lighting.
- C. The Contractor shall perform all excavations, complete all forms, and do backfilling and tamping as required, unless specifically shown otherwise on the Contract Drawings or stated in the Detailed Specifications.
- D. The following index of this Section is included for convenience:

<u>Article</u>	<u>Title</u>	<u>Page</u>
		16521-
PART 1	GENERAL .....	1
1.01	SECTION INCLUDES .....	1
1.02	RELATED SECTIONS .....	1
1.03	PAYMENT .....	2
1.04	REFERENCES .....	2
1.05	SUBMITTALS .....	2
1.06	QUALITY ASSURANCE .....	3
1.07	DELIVERY, STORAGE AND HANDLING .....	4
1.08	SPARE PARTS.....	4
PART 2	PRODUCTS.....	4
2.01	LUMINAIRES.....	4
2.02	POLES AND BASES .....	4
2.03	REINFORCED CONCRETE .....	5
PART 3	EXECUTION.....	5
3.01	INSTALLATION OF OUTDOOR LIGHTING.....	5
3.02	FIELD TESTS .....	5
3.03	CLEANING OF OUTDOOR LIGHTING .....	6

**1.02 RELATED SECTIONS**

- A. General Specification 02316 - Excavation
- B. General Specification 02317 - Backfilling
- C. General Specification 03300 - Cast-in-Place Concrete

## GENERAL SPECIFICATION 16521 – OUTDOOR LIGHTING

---

- D. General Specification 05120 - Structural Steel
- E. General Specification 16061 - Grounding
- F. General Specification 16511 - Lighting Fixtures and Devices

### 1.03 PAYMENT

- A. Payment for outdoor lighting shall be made as provided for in the Detailed Specifications.

### 1.04 REFERENCES

- A. Outdoor lighting shall comply with the latest applicable provisions and recommendations of the following:

1. DLC PR - Design Lights Consortium Premium Technical Requirements.
2. IES LM-79 - Approved Method: Electrical and Photometric Measurements of Solid-State Lighting Products.
3. IES LM-80 - Approved Method: Measuring Luminous Flux and Color Maintenance of LED Packages, Arrays and Modules.
4. IES TM-21 - Technical Memorandum on Projecting Long Term Lumen Maintenance of LED Light Sources.
5. NEMA SSL-1 - Electronic Drivers for LED Devices, Arrays, or Systems
6. NYCEC - New York City Electrical Code.
7. UL 1572 - High Intensity, Discharge Lighting Fixtures.
8. UL 1598 - Luminaires
9. UL 8750 - Light Emitting Diode Equipment for Use in Lighting Products.

### 1.05 SUBMITTALS

- A. Contractor shall submit Shop Drawings and material specifications for the approval of the Engineer. Submittal shall include, but not be limited to:
  1. A list of proposed manufacturers with the products they produce proposed for the contract.
  2. Manufacturer's catalog cuts and drawings showing all technical information, and construction details for luminaires, including dimensions, type of wiring,

## GENERAL SPECIFICATION 16521 – OUTDOOR LIGHTING

---

weight, size, installation methods and provisions for re-lamping luminaires from the ground.

3. Photometric data developed for each fixture including IES BUG ratings, isolux diagrams and IES lighting classification.
4. Lamp type and technical information.
5. Ballast type and technical information including power factor, input watts and ballast factor.
6. Driver type for LED and technical information including input voltage, power factor, Crest Factor and THD.
7. Pole and base construction details. For poles submit wind loading, complete dimensions and finish, include anchor bolt sizing and circle diameter.
8. Scaled Shop drawings showing the locations of all luminaires and shall include the proposed routing of supply conduits.
9. Bills of material.

B. Reports:

1. Field test reports shall be submitted.

### 1.06 QUALITY ASSURANCE

A. General:

1. Luminaires shall be UL listed and approved for use in the City of New York. The types of luminaires are noted within the fixture schedule. The descriptions and catalog numbers serve to establish the quality, appearance and performance of the specified luminaires.
2. Luminaires shall comply with DLC PR.
3. All luminaires shall be the products of lighting equipment manufacturers who have previously demonstrated, by performance and reputation, the ability to manufacture products of the quality specified. Such manufacturers must maintain an organization and manufacturing facility capable of actually manufacturing the specified luminaires. For the purpose of inspection, Contractor shall assure the Engineer, free and easy access to the manufacturing facilities and inventories of any manufacturer whose equipment the Contractor proposes to supply.
4. Outdoor lighting system shall use low carbon alloy steel with minimum yield strength of 50,000 p.s.i. or stainless steel bolts, nuts, washers and screws.
5. Contractor shall ensure that all metals used for poles, bases, support hardware, bolts, nuts washers and screws are of similar material composition and where different, steps are taken to mitigate the effects of corrosion.

## GENERAL SPECIFICATION 16521 – OUTDOOR LIGHTING

---

- B. Field Testing: The outdoor lighting system shall be field tested. The field testing shall be performed in accordance with the requirements specified under this Section.

### 1.07 DELIVERY, STORAGE AND HANDLING

- A. Outdoor lighting equipment shall be delivered, stored and handled in accordance with the Detailed Specifications and the manufacturer's instructions.

### 1.08 SPARE PARTS

- A. The Contractor shall furnish and deliver to the Engineer, at that part of the site and at such time as the Engineer may direct, spare parts for the outdoor lighting in accordance with the Detailed Specifications.
- B. The spare parts shall be listed in an index and packed in containers suitable for long term storage, bearing labels clearly designating the manufacturer's part number with complete information for use and reordering.
- C. The following spare parts shall be furnished, with all fractions rounded up to the next number:
  - 1. 10 percent lamps, lamp module or array shall be provided of each wattage of each type of lamp, lamp module or array but not less than the requirement for two luminaires.
  - 2. Where the lamp, lamp module or array is an integral part of the luminaire and the lamp, lamp module or array is not normally replaceable provide spare luminaires instead.
  - 3. 5 percent ballasts or drivers shall be provided of each type of type ballast or driver, but not less than two.
  - 4. 10 percent fuses shall be provided of each size and type, but not less than two.

## PART 2 PRODUCTS

### 2.01 LUMINAIRES

- A. Luminaires shall be provided in accordance with General Specification 16511 - Lighting Fixtures and Devices.
- B. Luminaires shall be provided for each lighting fixture symbol shown on the Contract Drawings and in accordance with the lighting fixture schedule shown in the Detailed Specifications.
- C. Heights of all outdoor luminaires shall be as shown on the Contract Drawings.

### 2.02 POLES AND BASES

- A. Poles and bases shall be provided in accordance with the details shown on the Contract Drawings.
- B. Poles shall have a wind load rating of at least 90 mph with a gust factor of 1.3.

## GENERAL SPECIFICATION 16521 – OUTDOOR LIGHTING

---

- C. Where shown on the Contract Drawings, bases shall be provided with plug receptacles, fuses, cut-outs, switches or other devices for protection and ease of maintenance. Devices shall be in accordance with the following:
  - 1. Receptacles shall be housed in cast iron hot-dipped galvanized boxes and shall be watertight, heavy duty type with screwed caps.
  - 2. Switches shall be enclosed in hot-dipped galvanized cast iron boxes. Where shown on the Contract Drawings switches shall be provided with fuses.
  - 3. Where shown on the Contract Drawings, fused applications shall be provided with watertight, in-line fuse kits similar to Buchanan breakaway street light connectors.

### 2.03 REINFORCED CONCRETE

- A. Concrete for pole foundations shall be in accordance with General Specification 03300 - Cast-in-Place Concrete, and the concrete steel reinforcement shall be in accordance with General Specification 05120 - Structural Steel.

## PART 3 EXECUTION

### 3.01 INSTALLATION OF OUTDOOR LIGHTING

- A. Luminaires shall be installed at locations indicated on the Contract Drawings. Fixture locations shall be adjusted where necessary to clear conflicts and obstructions.
- B. Excavation for luminaire poles shall be in accordance with the requirements of General Specification 02316 - Excavation. Backfilling for fixture poles shall be in accordance with the requirements of General Specification 02317 - Backfilling.
- C. Fixture poles shall be installed on reinforced concrete foundations as shown on the Contract Drawings. Poles shall be installed in accordance with standard procedures and as recommended by the manufacturer.
- D. Poles shall be wired with strain relief provided. A green grounding conductor shall be installed with each circuit, grounding by conduit method shall not be permitted.

### 3.02 FIELD TESTS

- A. After installation, the completed outdoor lighting system shall be field tested for operation and conformance. The field tests shall be witnessed by the Engineer and certified by the Contractor. The Contractor shall provide testing consisting of the following:
  - 1. Wiring continuity test shall be performed.
  - 2. Branch circuit load balance test shall be performed.
  - 3. Fixture and photo cell operation test shall be performed.
- B. The Contractor shall provide a field test report. The report shall identify the tests performed and the results obtained.

## **GENERAL SPECIFICATION 16521 – OUTDOOR LIGHTING**

---

### 3.03 CLEANING OF OUTDOOR LIGHTING

- A. Luminaires shall be cleaned inside and out to remove construction dust prior to substantial completion.
- B. Luminaires shall be re-lamped prior to substantial completion.

END OF SECTION

NO TEXT ON THIS PAGE

---

**THE CITY OF NEW YORK**  
**DEPARTMENT OF**  
**ENVIRONMENTAL PROTECTION**

---

**Invitation for Bids for Furnishing all Labor and Material  
Necessary and Required for:**

**Waterfowl Management Program Building and Paving**

**CRO-557G – STRUCTURES AND EQUIPMENT**  
**CRO-557H – HVAC**  
**CRO-557P – PLUMBING**  
**CRO-557E – ELECTRICAL**

**Volume 1 of 2**  
**Contract Terms and Specifications**  
**(with separate Bid Booklets)**

**January 2023**