



AIA[®] Document G710[™] – 2017

Architect's Supplemental Instructions

PROJECT: *(name and address)*
57-21113-00 - Rebid Dutchess Stadium
New Left Field Clubhouse, Seating Bowl,
& Restroom Building

CONTRACT INFORMATION:
Contract For: General Construction

ASI INFORMATION:
ASI Number: 004

Date:

Date: June 2, 2023

OWNER: *(name and address)*
Dutchess County
22 Market Street
Poughkeepsie, NY 12601

ARCHITECT: *(name and address)*
DLR Group Architecture and Engineering,
P.C., a New York professional corporation
33 East 33rd Street, Suite 401
New York, NY 10016

CONTRACTOR: *(name and address)*
Piazza, Inc.
3 W Stevens Avenue
Hawthorne, NY 10532

The Contractor shall carry out the Work in accordance with the following supplemental instructions without change in Contract Sum or Contract Time. Proceeding with the Work in accordance with these instructions indicates your acknowledgment that there will be no change in the Contract Sum or Contract Time.
(Insert a detailed description of the Architect's supplemental instructions and, if applicable, attach or reference specific exhibits.)

Modify the Contract Documents per the attachments and generally as follows:

1. Sheet C4.1.ii – CIVIL UTILITY PLAN 1
 - a. Modifications per the attached sheet.
2. Sheet C5.1.ii – CIVIL DETAILS
 - a. Modifications per the attached sheet.

Attachment(s):
Revised Sheet C4.1.ii – CIVIL UTILITY PLAN 1
Revised Sheet C5.1.ii – CIVIL DETAILS

ISSUED BY THE ARCHITECT:

DLR Group Architecture and Engineering,
P.C., a New York professional corporation

ARCHITECT *(Firm name)*

SIGNATURE

Bob Carlson, AIA, LEED AP,
Principal

PRINTED NAME AND TITLE

June 2, 2023

DATE

- THE DESIGN, CONSTRUCTION AND INSTALLATION SHALL BE IN ACCORDANCE WITH THIS PLAN AND GENERALLY ACCEPTED STANDARDS IN EFFECT AT THE TIME OF CONSTRUCTION, WHICH INCLUDE:
 - RECOMMENDED STANDARDS FOR WATER (TEN STATES)
 - RURAL WATER SUPPLY, NEW YORK STATE DEPARTMENT OF HEALTH
 - NEW YORK STATE DEPARTMENT OF HEALTH AND DUTCHESS COUNTY DEPARTMENT OF HEALTH POLICIES, PROCEDURES, AND STANDARDS
 - DUTCHESS COUNTY DEPARTMENT OF HEALTH SANITARY CODE, ARTICLE XI AND ARTICLE V
 - DUTCHESS COUNTY DEPARTMENT OF HEALTH CERTIFICATE OF APPROVAL

- UPON COMPLETION OF THE FACILITIES, THE FINISHED WORK SHALL BE INSPECTED, TESTED, AND CERTIFIED COMPLETE TO THE DUTCHESS COUNTY HEALTH DEPARTMENT BY THE NEW YORK STATE LICENSED PROFESSIONAL ENGINEER SUPERVISING CONSTRUCTION. NO PART OF THE FACILITIES SHALL BE PLACED INTO SERVICE UNTIL ACCEPTED BY THE DUTCHESS COUNTY HEALTH DEPARTMENT. THE NEW WATER SUPPLY SYSTEM SHALL NOT BE PLACED INTO SERVICE UNTIL A COMPLETED WORK APPROVAL IS ISSUED UNDER SECTION 5-1.22(d) OF PART 5 OF THE NEW YORK STATE SANITARY CODE (10NYCRRS).
- DISINFECTION AND TESTING OF WATER MAIN SHALL COMPLY WITH THE SPECIFICATIONS.
- THE RESULTS OF THE BACTERIOLOGICAL SAMPLING AND LEAKAGE TESTS SHALL BE SUBMITTED TO THE DUTCHESS COUNTY DEPARTMENT OF HEALTH AS PART OF THE CERTIFICATION BY A NEW YORK STATE LICENSED PROFESSIONAL ENGINEER.
- THRUST RESTRAINTS SHALL BE INSTALLED PER THE SPECIFICATIONS AND AS DETAILED ON THE NYSDOT STANDARD SHEETS 663-02 AND 663-03.
- THE CONTRACTOR SHALL LOCATE THE EXISTING WATER MAIN TO CONFIRM ELEVATION, SIZE, AND MATERIAL PRIOR TO CONSTRUCTION AND PRIOR TO ORDERING ANY MATERIALS. ANY ADJUSTMENTS TO THE ALIGNMENT OF THE NEW WATER LINE SHALL BE SUBMITTED TO THE ENGINEER FOR APPROVAL.
- UTILITY WORK ACROSS ROUTE 9D SHALL BE PER NYSDOT HIGHWAY WORK PERMIT REQUIREMENTS.
- IF THE INSTALLATION OF SANITARY SEWER CROSSING 9D IS TO BE PERFORMED BY DIRECTIONAL BORING, THE EXISTING GAS LINE ON ROUTE 9D SHALL BE EXPOSED AND MONITORED DURING BORING OPERATIONS.
- ALL TRAFFIC CONTROL SHALL BE PER THE 619 SERIES NYSDOT STANDARD SHEETS AND CAN BE ALTERED AT ANY TIME BY NYSDOT. ALLOWABLE TIMES FOR LANE CLOSURES WILL BE DETERMINED BY NYSDOT. NO ADDITIONAL PAYMENT WILL BE MADE FOR ANY CHANGES TO THE TRAFFIC CONTROL SCHEME(S) AS ORDERED BY NYSDOT OR LOCAL MUNICIPALITY.

2

GRID NORTH

NYS Route 9D
(State Highway No. 551)

NYS Route 9D
(State Highway No. 551)

1
2
3
4
5

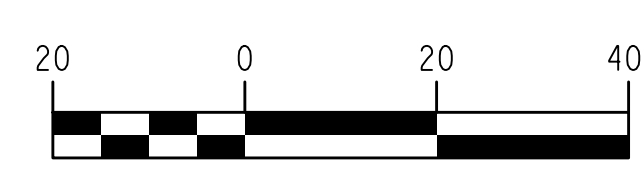
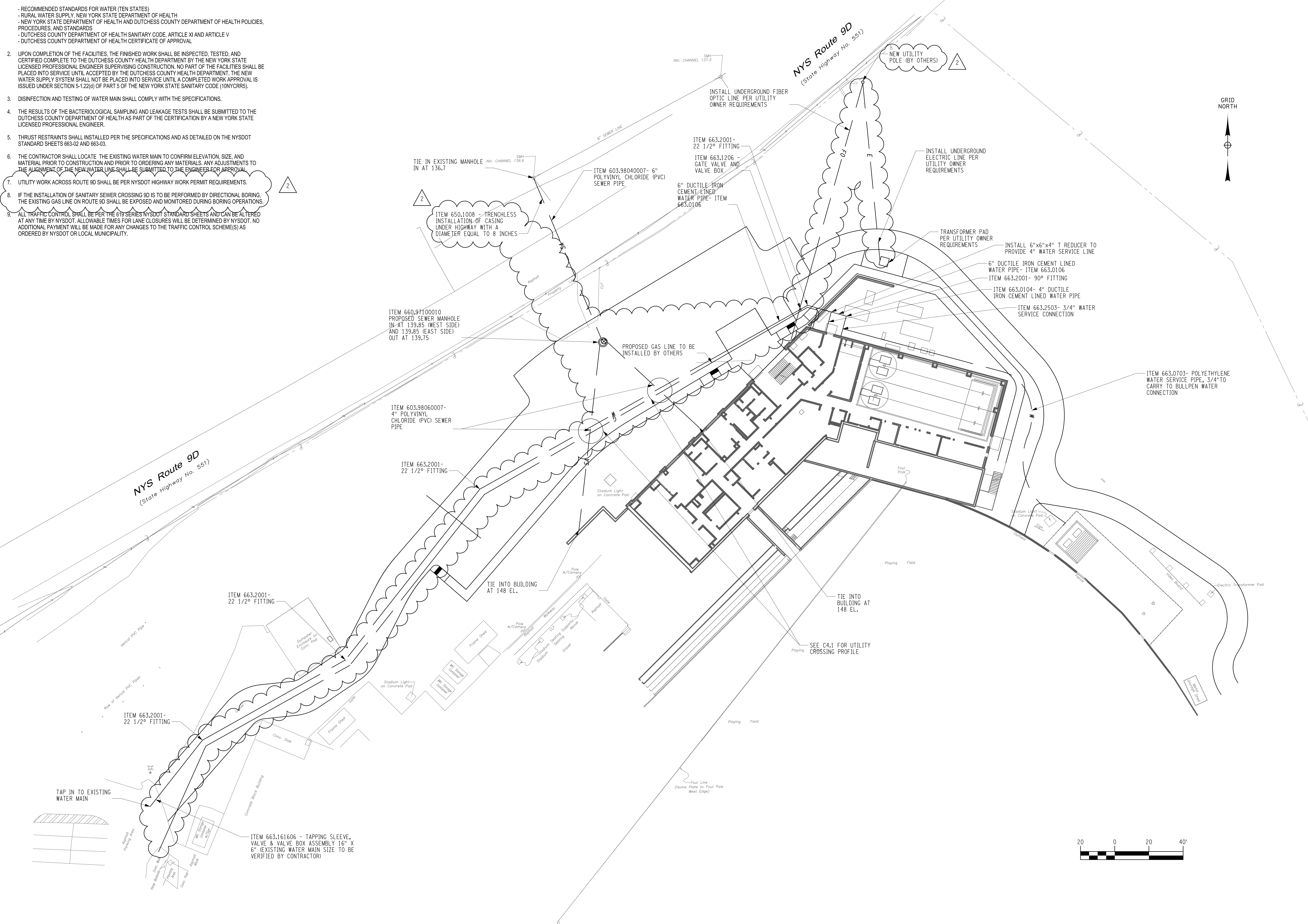

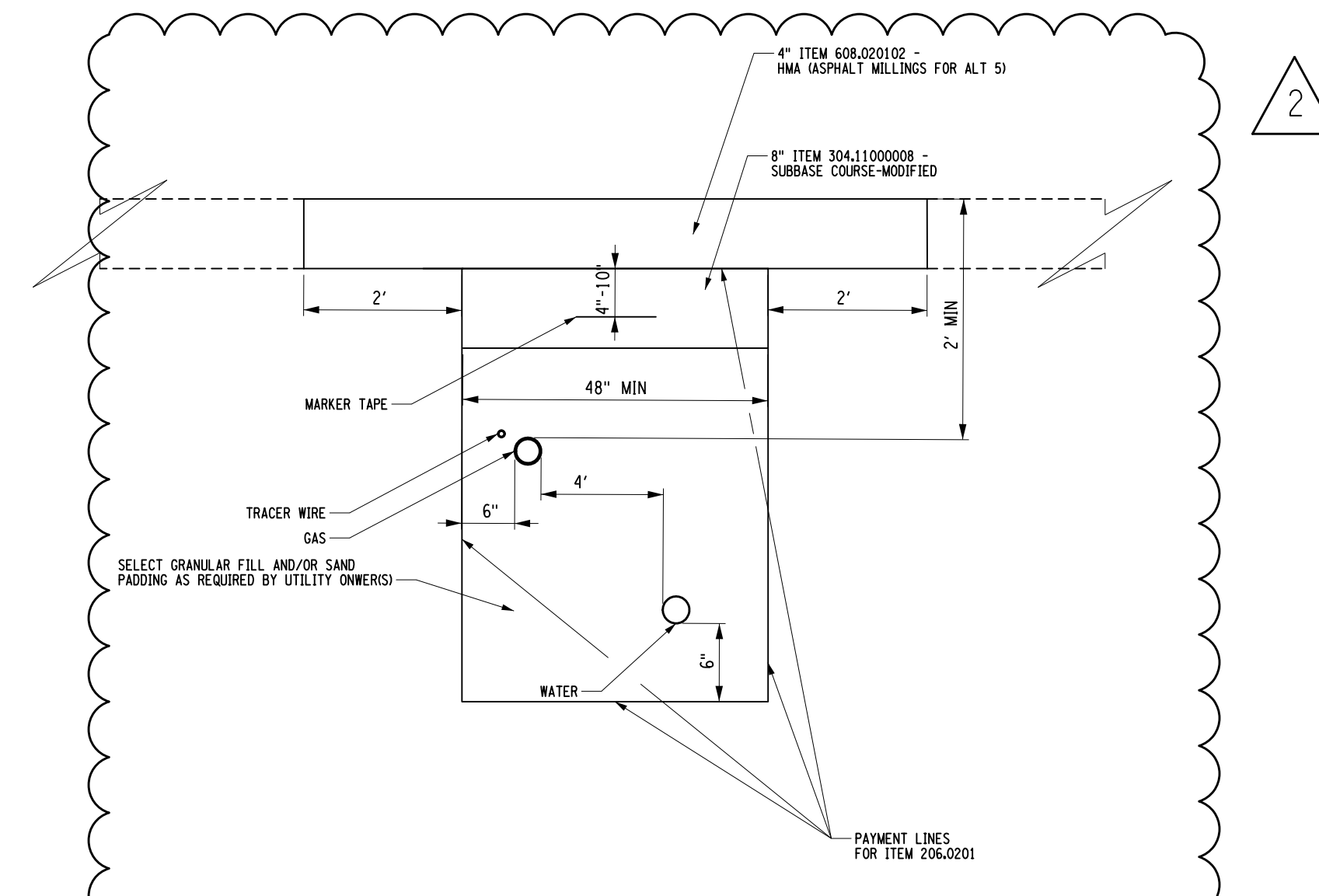
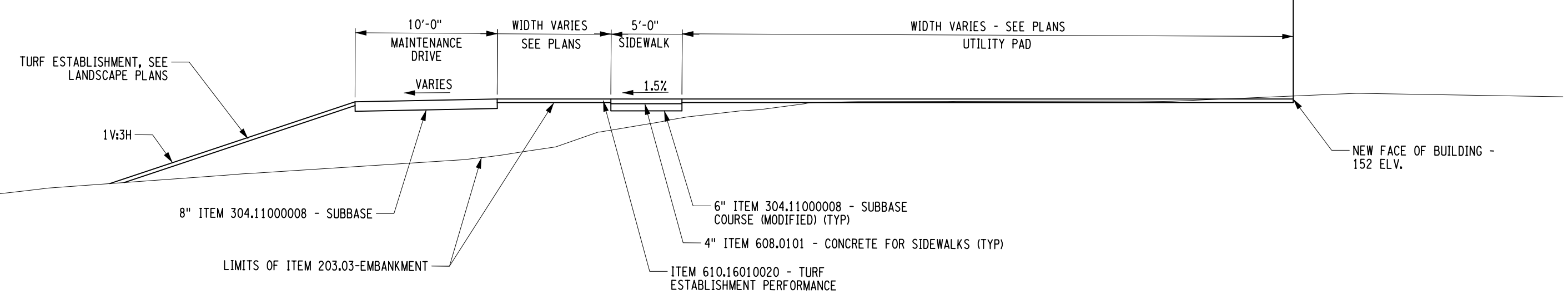
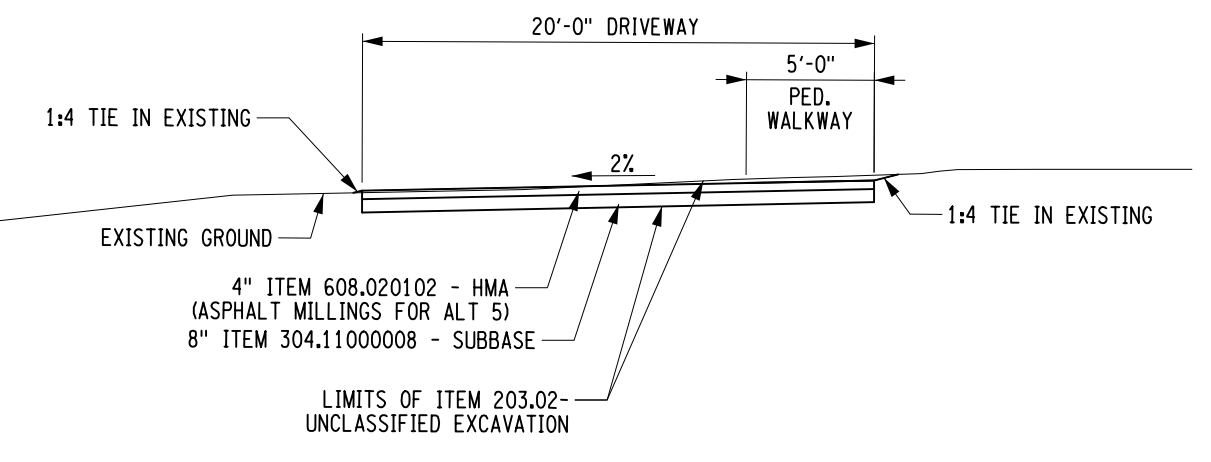
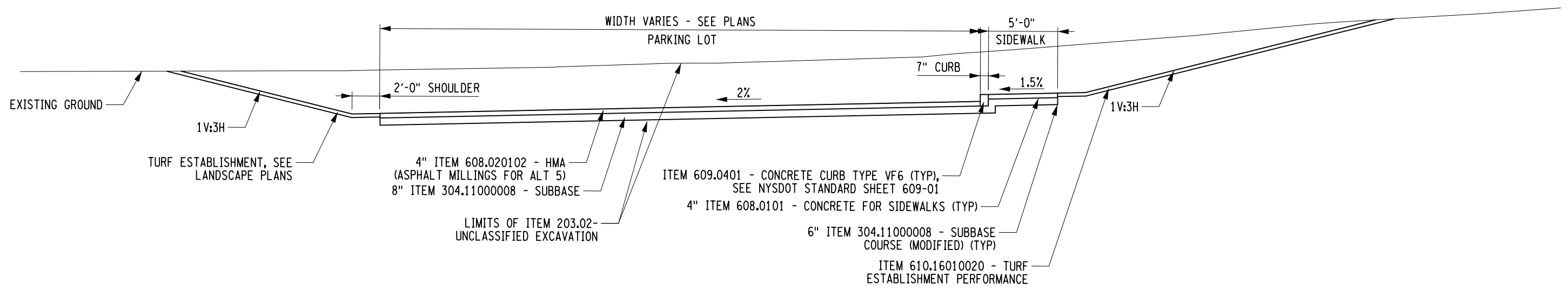
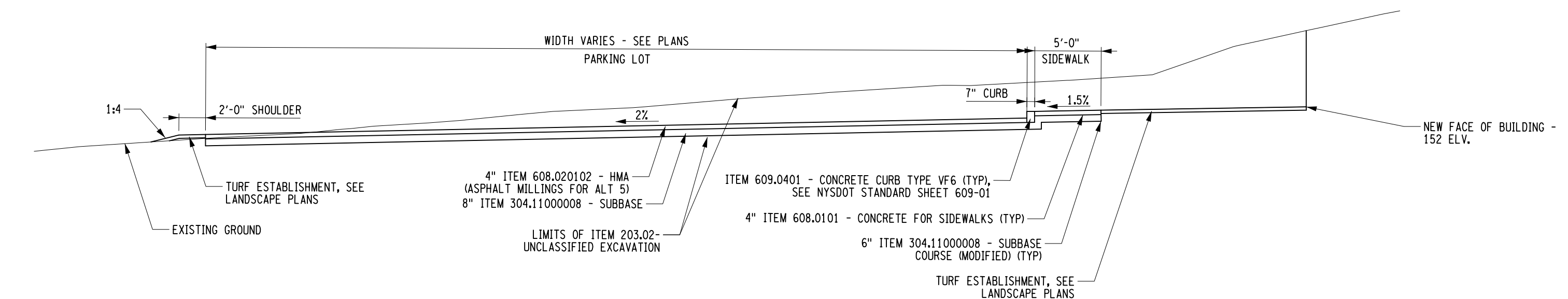

- NOTES:**
1. THE TRENCH SHALL BE BACKFILLED ABOVE ITEM 203.07 LIMIT WITH SUITABLE MATERIAL. IF MATERIAL EXCAVATED FROM THE TRENCH IS DEEMED "UNUSABLE" BY THE ENGINEER, IT SHALL BE DISPOSED OF AS PER SECTION 206-3.01. BACKFILL OF THE TRENCH SHALL BE DONE WITH SUITABLE MATERIAL CONFORMING TO SECTION 203-3.010. THE COST OF THIS MATERIAL, REGARDLESS OF THE SOURCE, SHALL BE INCLUDED IN ITEM 206.0201.
 2. ITEM 407.0103 - STRAIGHT TACK COAT WILL BE USED BETWEEN ALL LAYERS/LIFTS OF ASPHALT AND ON VERTICAL FACE OF SAWCUT IN ACCORDANCE WITH TABLE 407-1 OF THE NYSDOT STANDARD SPECIFICATIONS.
 3. SUPPORT OF THE EXCAVATION SHALL BE DESIGNED BY THE CONTRACTOR AND SUBMITTED TO THE ENGINEER AND NYSDOT FOR REVIEW AND APPROVAL. THE SUPPORT SHALL ENSURE THAT VEHICLE LOADING CAN BE CARRIED WITHOUT FAILURE OF THE SIDE SLOPES. IF STEEL PLATES ARE TO BE USED TO COVER THE TRENCH WHEN REOPENING THE ROAD TO TRAFFIC, THEY SHALL BE APPROVED BY THE ENGINEER AND NYSDOT.

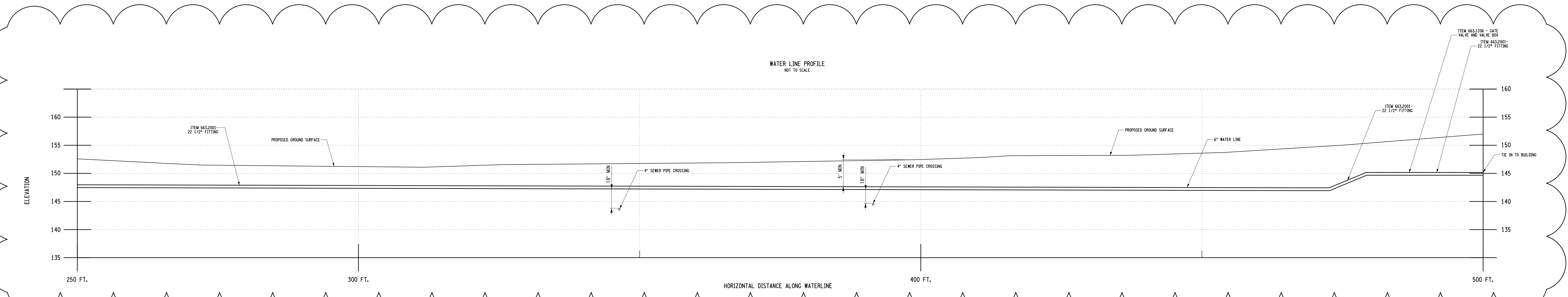
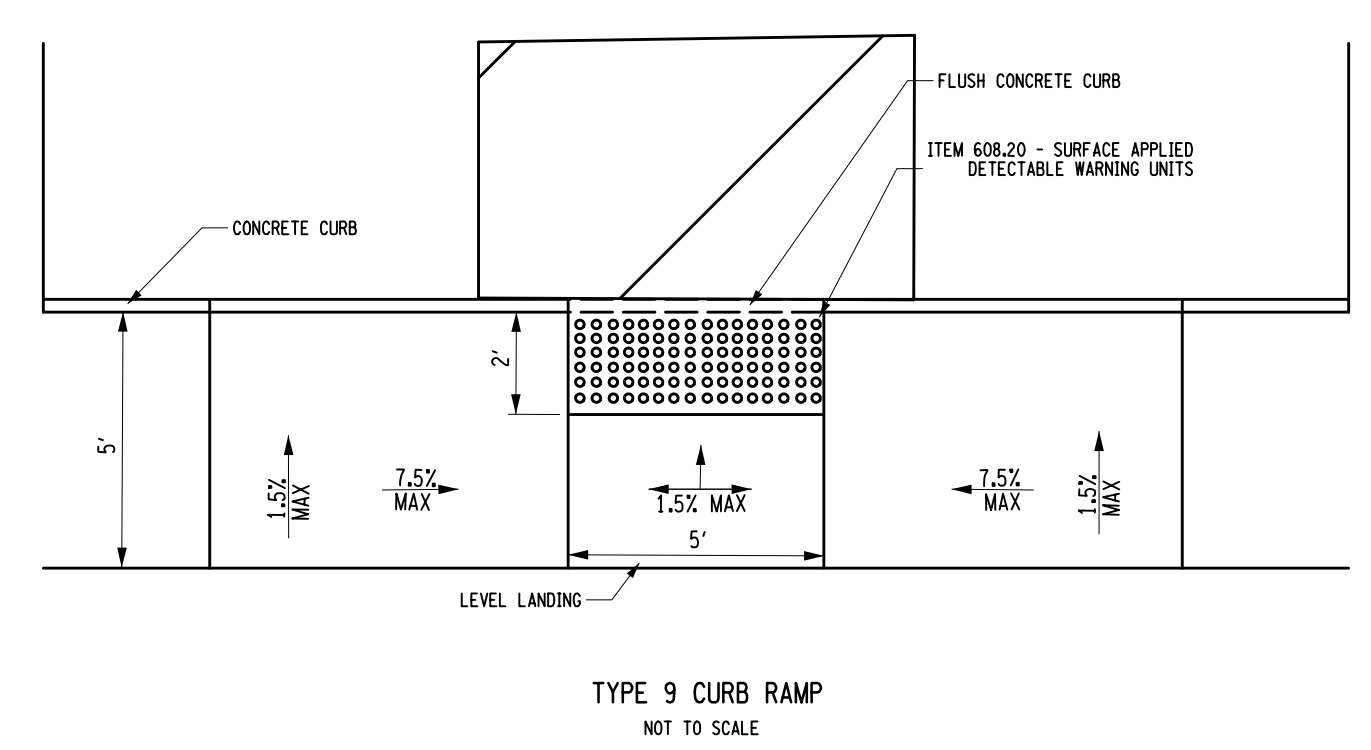
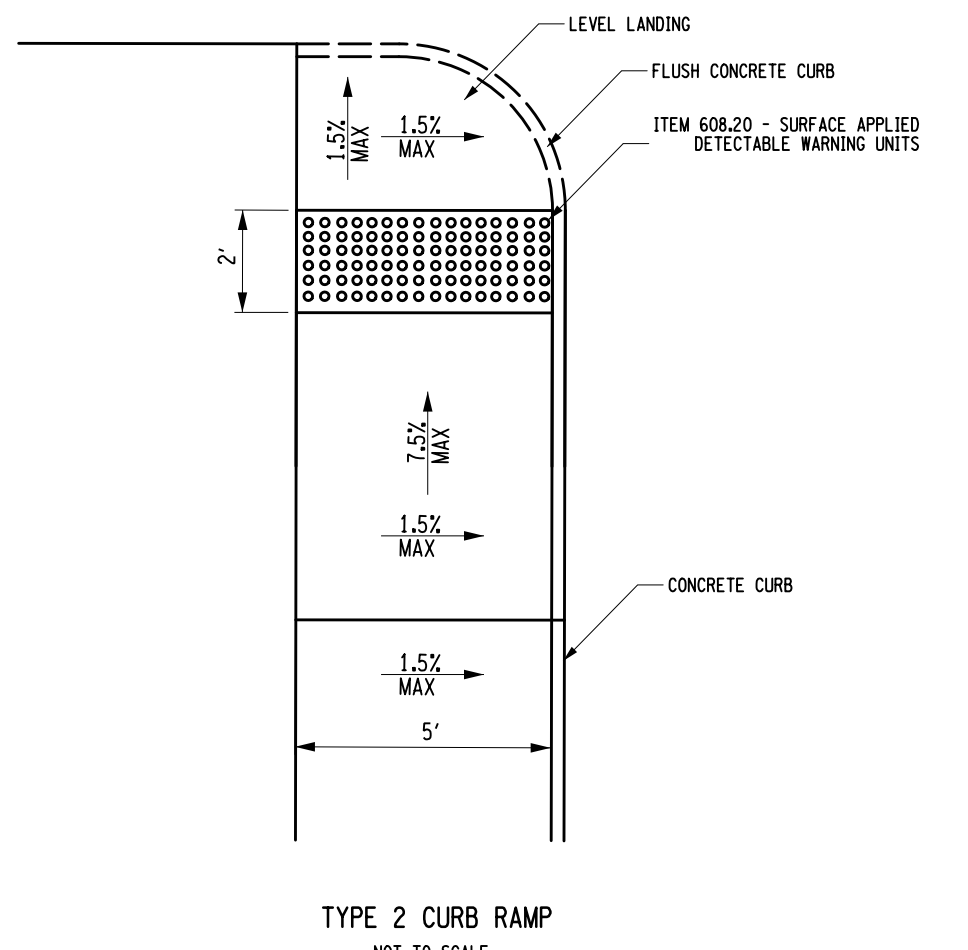

1
2
3
4
5

2