

BID ADDENDUM NO. 2

Date of Addendum: March 31, 2026
Issued for Bid Date: March 27, 2026
Client Name: Public Schools of the Tarrytowns
Project Name: 2024 Capital Bond Project – Phase 2; Washington Irving Intermediate School
SED Project No.: 66-04-01-03-0-002-017
TUFSD Bid Number: 25/26-TUFSD-003
MEMASI Project No.: 101-2403
Contracts: Contract 1: General Construction (GC)
Contract 2: Mechanical Construction (MC)
Contract 3: Electrical Construction (EC)
Contract 4: Plumbing Construction (PC)

This Bid Addendum forms part of the Contract Documents and modifies the original Issued for Bid Documents dated March 27, 2026. Where provisions of the following supplementary information differ from those of the original Bid Documents, this Addendum shall govern and take precedence.

The Bid Documents are modified and clarified as follows:**1. CHANGES TO THE PROJECT MANUAL**

- a. SECTION 114000 – FOOD SERVICE EQUIPMENT; ADD Section 114000 – Food Service Equipment, attached, in its entirety.

2. CHANGES TO THE DRAWINGS

- a. SHEET FS100 – FOOD SERVICE EXISTING EQUIPMENT PLAN; ADD Sheet FS100 – Food Service Existing Equipment Plan, attached.
- b. SHEET FS101 – FOOD SERVICE EQUIPMENT PLAN; ADD Sheet FS101 – Food Service Equipment Plan, attached.
- c. SHEET FS102 – FOOD SERVICE PLUMBING PLAN; ADD Sheet FS102 – Food Service Plumbing Plan, attached.
- d. SHEET FS103 – FOOD SERVICE ELECTRICAL PLAN; ADD Sheet FS103 – Food Service Electrical Plan, attached.
- e. SHEET FS104 – FOOD SERVICE WALK IN DETAILS; ADD Sheet FS104 – Food Service Walk In Details, attached.
- f. SHEET FS105 – FOOD SERVICE REFRIGERATION DETAILS; ADD Sheet FS105 – Food Service Refrigeration Details, attached.
- g. SHEET FS106 – FOOD SERVICE EXHAUST HOOD DETAILS; ADD Sheet FS106 – Food Service Exhaust Hood Details, attached.
- h. SHEET FS107 – FOOD SERVICE EXHAUST HOOD DETAILS; ADD Sheet FS107 – Food Service Exhaust Hood Details, attached.
- i. SHEET FS108 – FOOD SERVICE SERVING LINE DETAILS; ADD Sheet FS108 – Food Service Serving Line Details, attached.
- j. SHEET FS109 – FOOD SERVICE SERVING LINE DETAILS; ADD Sheet FS109 – Food Service Serving Line Details, attached.
- k. SHEET FS110 – FOOD SERVICE SERVING LINE DETAILS; ADD Sheet FS110 – Food Service Serving Line Details, attached.

END OF BID ADDENDUM NO. 2

SECTION 114000 – FOOD SERVICE EQUIPMENT

PART 1- GENERAL

1.1 SECTION INCLUDES:

- A. Foodservice Equipment as listed in the itemized specifications and listed in the contract drawings.

1.2 DEFINITIONS:

- A. Furnish -- Supply and deliver to the project site, ready for unloading, unpacking, setup, assembly, and installation.
- B. Install -- Will include the actual unloading, unpacking, assembly, erecting/setting in place, leveling, anchoring, protecting, cleaning, and related operations on the equipment to be made ready for utility connections by other trades as indicated.
- C. Contractor -- All references for the Contractor in this Section 114000 shall refer to the Food Service Equipment Contractor (abbreviated as FSEC). Reference to any other contractor or subcontractor, shall be specific as such:
 - 1. General Contractor (abbreviated as GC)
 - 2. Plumbing Contractor (abbreviated as PC)
 - 3. Electrical Contractor (abbreviated as EC)
 - 4. Mechanical Contractor (abbreviated as MC)

1.3 RELATED SECTIONS:

- A. Refer to General Conditions, Supplementary Conditions, and applicable provisions for additional instructions.
- B. Refer to Mechanical Section for applicable provisions and sections regarding mechanical services, including, but not limited to, rough-ins, grease traps, steam traps, drain traps, atmospheric vents, valves, pipes and pipe fittings, ductwork, and other materials necessary to complete final connections to individual items as specified in this Section.
- C. Refer to Electrical Section for applicable provisions and sections regarding electrical services, including, but not limited to, rough-ins, wiring, disconnects, and other materials necessary to complete final connections to individual items as specified in this Section.
- D. Work included in other Sections will include provision of any wall, floor, and/or ceiling/roof openings, penetrations, recesses, sleeves, conduits, and equipment pads as required for installation of items included in this section. Also sealing of these openings, penetrations, recesses, sleeves, etc., after installation of the equipment items as required. Such work is not included in this Section. Work included in other Sections -- Disconnection of existing equipment to be relocated and/or reused; and disconnection of existing equipment which will not be reused, shall be as determined, and designated by the Architect in other Sections. Mounting and installation of gas regulators, gas hoses, gate valves, water hammer arrestors, back flow preventers, water filters, faucets, lever drains, and drain lines, and pressure-reducing valves will be performed by the plumbing contractor. Such work is not included in this section.
- E. Work included: The owner may wish to retain equipment that is not going to be reused. Verify all items with the owner prior to removal. If the owner wishes to retain some items, deliver these items to a designated place as directed by the owner. Removal and disposal of existing equipment, which will not be re-used, shall be the responsibility of the Food Service Equipment Contractor. Removal of existing equipment, which will be reused, shall be the responsibility of the

FSEC. This equipment shall be removed from the site, stored, cleaned, and delivered ready for final connections by others. Disconnection of utilities performed by others. All existing equipment shall be relocated as per the contract drawings. FSEC shall be responsible for pumping down and properly recovering the existing refrigerant from any systems prior to demolition. The FSEC is responsible for installation of the walk-in cooler/freezer and refrigeration systems, the new hoods, and all equipment shown in the plans and in the Itemized specifications below. The FSEC is responsible for mounting any hand sinks or water filter systems sink on the wall. FSEC is to confirm ability and sizing of equipment to be installed and access into the room.

1.4 STANDARDS, LAWS, AND ORDINANCES:

A. Standards: Except and unless otherwise noted, comply with the following standards as applicable to the manufacture, fabrication, and installation of the work of this Section:

1. American with Disabilities Act (ADA): Comply with requirements, as applicable to this Project.
2. National Sanitation Foundation (NSF): Comply with the latest Standards and Revisions established by NSF for equipment and installation. Provide NSF seal of approval on each applicable manufactured item, and on items of custom fabricated work.
3. Underwriters Laboratories (UL): For electrical components and assemblies provide either UL labeled and registered products or, where no labeling service is available, recognized markings to indicate listing in the UL Recognized Component Index.
4. National Fire Protection Association (NFPA): Comply with the applicable sections of the current NFPA codes for exhaust hood, ventilators, duct and fan materials, hood wet chemical fire suppression systems, construction, and installation, as well as any local codes and standards.
5. Wet chemical fire suppression systems for exhaust hoods/ventilators shall comply with UL 300 Standard or most current standard.
6. National Electrical Manufacturers Association (NEMA): Comply with the most current codes or standards.
7. American Gas Association (AGA): Comply with AGA standards for gas heated equipment and provide equipment with the AGA seal. Automatic safety pilots are to be provided with all equipment whenever available.
8. American National Standards Institute (ANSI): Comply with current standards for gas-burning equipment and provide labels indicating name of testing agency. Comply with current codes and standards for L.P. gas cylinder connections, and with applicable standards of the Compressed Gas Association for compressed gas piping. Follow codes for water connection air gaps and vacuum breakers.
9. American Society of Mechanical Engineers (ASME): Comply with ASME Boiler Code requirements for steam generating and steam heated equipment. Provide ASME inspection stamp and registration with National Board.
10. American Society for Testing and Materials (ASTM): Comply with current requirements for flat glass. Comply with codes for heat-treated flat glass, Kind HS, Kind FT coated, and uncoated glass.
11. National Electric Code (NEC): Comply with current NFPA codes for electrical wiring and devices included with foodservice equipment, and applicable NEMA and NECA standards.

12. American Society of Heating, Refrigeration, and Air Conditioning Engineers (ASHRAE): Comply with the applicable regulations and references of the latest edition of standards for remote refrigeration systems, components, and installation.
13. Air Conditioning and Refrigeration Institute (ARI): Comply with the applicable regulations and references of the latest edition of standards for remote refrigeration systems, components, and installation.
14. Refrigeration Service Engineers Society (RSES): Comply with the applicable regulations and references of the latest edition of standards for remote refrigeration systems, components, and installation.
15. No CFC refrigerants shall be allowed on this project under any circumstances. HFC refrigerants and components shall be used where available. R290 refrigerant should be used where possible.
16. All walk-in coolers and freezers shall meet the applicable sections of NYECC C403.10.
17. All refrigeration components installation, repairs, and/or associated work on any refrigeration system, self-contained or remote, shall be performed by a Certified Refrigeration Mechanic.
18. All applicable local codes, standards, and regulations and any special local or job site conditions shall be complied with.

1.5 SUBSTITUTIONS:

- A. All substitutions for itemized equipment specified will require prior approval of the Foodservice Consultant and owner. Such requests must be made in writing no later than ten (10) business days prior to the bid due date. If approved, an addendum will be issued to all bidders at least five (5) business days prior to bid due date. All requests for substitutions shall comply with conditions and requirements as stated in Section 1.6 below.
- B. If custom fabricated items are submitted, and accepted as a substitute for standard manufactured items, these items shall meet the specifications of the specified manufactured items, in general, the fabrication section of this document.

1.6 APPROVED SUBSTITUTIONS OR ALTERNATES:

- A. Substitutions approved by addendum as noted in Section 1.5, and/or any alternate manufacturers listed in the Itemized Specifications, may be utilized, with the following conditions:
 1. The contract documents are designed and engineered using the primary specified manufacturer and model. The Food Service Equipment Contractor shall assume total responsibility for any deviations required due to the utilization of a substitution/alternate manufacturer or model, including but not limited to, fitting alternates into the available space, providing directions to the General Contractor for required changes, and assuming any associated cost for utility, building, architectural, or engineering changes.
 2. The submittal of an alternate manufacturer or model shall indicate agreement to the above stated conditions. At the Owner's sole discretion, failure to comply with any of these conditions, or to supply complete and correct data information shall result in the Food Service Equipment Contractor being required to provide the originally specified manufacturer and model at no additional cost to the owner.

3. Inclusion of an alternate manufacturer in the Itemized Specifications is not intended to indicate that there is an equal alternate unit to match every primary specified unit. It shall be the responsibility of the Food Service Equipment Contractor to ensure that the alternate unit submitted matches the primary specified unit, including all listed options and accessories, and meets the other project conditions.
4. The Food Service Equipment Contractor shall be responsible for supplying the model, which is equal to the primary specified model regarding general function, features, options, sizes, accessories, utility requirements, finish, operation, and listing approvals. If it is determined by the owner, or their appointed representative, at any time during the construction and installation prior to the final acceptance of the project, that the substitution / alternate model submitted is not equal to the primary specified model, the Food Service Equipment Contractor shall assume all associated costs, and implications required to replace the model submitted with the originally specified brand and model.
5. The Food Service Equipment Contractor's bid will clearly list any substitutions or alternates to be used, including the manufacturer and model number. The proposal shall also include a manufacturer's specification/data sheet for each substitution / alternate, with any, and all deviations between the specified manufacturer and the alternate manufacturer itemized and listed. Submittal of a manufacturer's specification sheets shall not be acceptable as the data sheet. Complex alternates such as utility distribution systems, exhaust hoods, walk-in coolers/freezers, custom fabricated items, etc., will require shop drawings specific to this project.
6. Manufacturers not approved for substitutions, or listed as an approved alternate will not be permitted, unless submitted for prior approval as described above in Section 1.5, paragraph A.

1.7 SUBMITTALS:

A. Rough-In Drawings:

1. The Food Service Equipment Contractor shall be solely responsible for the accuracy of the information provided in the submittal packages.
2. In the event utility rough ins have been accomplished before a contract is awarded to the Food Service Equipment Contractor, the FSEC shall check the existing facility and adjust their equipment to suit job site conditions and utilities where possible. If this is not possible, immediately send a letter with reasons, practical solutions, and any costs associated with the proposed solutions to the owner and the Foodservice Consultant.
3. Submit required number of sets as directed by the architect for approval. After approval, reproduce, and supply the required number of distribution prints for the other trades for construction purposes.
4. If the architect utilizes an electronic submittal service or process, after approval, supply the required number of distribution prints for the other trades for construction purposes.
5. Submit minimum 3/8 inch per foot scale rough-in drawings for approval. These drawings shall be dimensioned, showing location of ducts, stubs, floor, and wall sleeves for ventilation, plumbing, steam, electrical, refrigeration lines, and concrete base/recess/curb dimensions as required for equipment. Drawings shall be submitted in a minimum of 24" x 36" format.
6. Verify mechanical, electrical, ventilating rough in, and sleeve penetration locations at

project site as required.

B. Shop Drawings:

1. Submit shop drawing sets as directed by the architect for approval. After approval, reproduce, and supply the required number of distribution prints for the other trades for construction purposes.
2. Submit CAD shop drawings in PDF format for items of custom fabrication included in this contract. Shop drawings shall be submitted at minimum 3/4 inches per foot scale, and shall show dimensions, materials, construction details, installation, and relation to adjoining work or equipment requiring cutting or close fitting. Shop drawings shall also indicate all reinforcing, anchoring, and related work required for the complete installation of these items. Drawings shall be submitted in a minimum of 24" x 36" format.
3. Before proceeding with the fabrication of any item, the Food Service Equipment Contractor will verify all necessary dimensions and details with all job site dimensions and conditions considered.

C. Submittals:

1. Submit an Equipment Manual with a cover sheet, and detailed information on every item included in the Itemized Equipment List. This information shall include but not limited to items and model numbers, basic description, quantity required, all options and accessories to be provided, exact utility requirements, manufacturer specification sheets, reference to specific shop drawings, etc. Mark each data sheet with the applicable project equipment item number. Highlight model numbers and/or accessories on each sheet for a clear indication of what is included in the submittal. Each data sheet includes NEMA plug and receptacle configuration for applicable items. Every cover sheet and associated detailed submittal shall provide sufficient and complete information to verify that the Food Service Equipment Contractor is providing each item in compliance with the Contract documents.
2. Architect / Foodservice Consultant review of shop drawings, and equipment manuals is for general conformance and compliance with the design concept, and contract documents. Markings, and / or comments shall not be construed as relieving the Food Service Equipment Contractor from compliance with the contract documents. The Food Service Equipment Contractor remains solely responsible for all details and accuracy and for performing their work in a safe, satisfactory, and professional manner.

1.8 OPERATION AND MAINTENANCE MANUALS:

- A. Operation and Maintenance Manuals: The Food Service Equipment Contractor will supply a set of manuals for items of standard manufacture on, or before, the date of final acceptance of installation by the owner. Manuals are to be in alphabetical order according to the manufacturer. Each set should include a blank page for quick reference, clearly marked, separating each manual and / or section within the binder. Electronic versions are acceptable unless printed versions are required by the architect, owner, or construction manager.
- B. Submit with the operation and maintenance manuals a list of local service agencies complete with telephone numbers, address, and e-mail information for the authorized agencies to perform the warranty work.
- C. Provide a letter of warranty in the front of the manual complying with Section 1.14. This letter must include the actual date the warranty begins, and list all labor, service, workmanship, and factory warranty periods.

1.9 AS BUILT AND RECORD DOCUMENTS:

- A. Maintain one record set of Foodservice Equipment Plans with any related corrections, revisions, additions, deletions, changes, future items, etc. noted during construction and installation.
- B. Provide final sets of shop drawings and equipment manuals with any related corrections, revisions, additions, deletions, changes, future items, etc. noted during construction and installation as a specifications record set.
- C. These documents shall be provided to the owner before the date of final acceptance of installation.

1.10 DISCREPANCIES

- A. If discrepancies are discovered between the drawings and the specifications, the FSEC will notify the Food Service Consultant in writing of any discrepancies discovered and await clarification prior to proceeding with the items or areas in question.

1.11 FOOD SERVICE EQUIPMENT CONTRACTOR QUALIFICATIONS:

- A. Submit evidence of compliance with the following qualifications and conditions.
 - 1. Manufacturers' authorized dealer, able to purchase, distribute, and install all items specified in this project.
 - 2. Seven (7) years minimum continuous operation under the same company name and ownership.
 - 3. Successfully completed at least eight (8) installations of similar scope and size during the last two (2) years. Provide references with contact information for verification.
 - 4. Maintain installation staff or have access to qualified personnel with a minimum of seven (7) years' experience in the installation of comparable size and scope projects.
 - 5. Maintain a staff or have access to personnel experienced in the preparation of professional shop drawings and submittals as outlined in related sections.
 - 6. Maintain or have access to manufacturers authorized service personnel together with readily available stock of repair, and replacement parts.
 - 7. Maintain or have access to a fabrication shop with NSF and UL standards and officially listed with labeling requirements. If the fabricator will be a subcontractor for the FSEC, they shall have ten (10) years minimum experience in the fabrication of comparable size, scope, and level of quality projects. The Food Service Equipment Contractor shall submit the fabrication shop company name and credentials to the Foodservice Consultant and owner, who shall have the right of approval or disapproval of this fabricator.
- B. Any subcontractor employed by Food Service Equipment Contractor for this project shall comply with these same qualification requirements.
- C. The Architect and/or Foodservice Consultant for the project shall approve the Food Service Equipment Contractor.

1.12 PRODUCT HANDLING:

- A. Storage of Materials, Equipment, and Fixtures. The Food Service Equipment Contractor is responsible for receiving and warehousing equipment and fixtures and holding items until the job site is ready for delivery and installation.
- B. Handling Materials and Equipment. Verify and coordinate conditions at the job site, particularly door, and/or wall opening sizes and clearances, to assure access for all equipment. Pieces too large for existing site conditions shall be hoisted, crane-lifted, or otherwise handled as required. All special handling equipment charges shall be arranged for and paid for by the Food Service Equipment Contractor and are to be included in the bid price, unless conditions change at the job site, after acceptance of bid through no fault of the FSEC.

1.13 PRODUCT PROTECTION:

- A. The Food Service Equipment Contractor is responsible during the progress of the project to protect their equipment against theft or damage, until final acceptance by the owner. Items should not be delivered to the job site before the site is ready for installation, unless at the request of the owner or the construction manager. All scheduled deliveries should be signed for and the delivery condition noted by the owner or the construction manager.
- B. Protect all items before, during, and after installation and protect the associated work and materials of the other trades.

1.14 WARRANTIES:

- A. Unless otherwise noted, items furnished shall be fully guaranteed against defects in workmanship and material(s) for two (2) full years from the date of the first event to occur of the following: Start-up for intended use by the owner/operator, Substantial completion of installation of kitchen equipment contract package as agreed to by the owner, or final acceptance of installation by the owner. Should a Temporary Certificate of Occupancy be issued for partial completion of work, the items furnished within that designated area shall be under warranty from the date of issue of the certificate. The Food Service Equipment Contractor or their service agent will make repairs and replacements without charge to the owner within a reasonable time.

1.15 SCHEDULE:

- A. Contract acceptance constitutes a guarantee that the contractor can and will obtain materials, equipment, and labor upon notice to proceed to permit overall completion of the entire building project on schedule. The contractor shall coordinate their work with the progress schedule as prepared and updated periodically by the General Contractor, or the Construction Manager.
- B. Anticipated delays, not through fault of the Food Service Equipment Contractor, shall be noted in a written notification to the Foodservice Consultant, and the Architect immediately upon the realization by FSEC that delays are possible, or probable.
- C. Extra charges from rush orders, special handling, overnight UPS/FedEx, air shipments, etc., to meet the required schedule will be paid by the Food Service Equipment Contractor, if insufficient time was allowed in placing factory orders.
- D. Failure of manufacturers to meet promised delivery dates will not grant relief to the Food Service Equipment Contractor for failure to meet schedules unless it can be proven in writing with supporting data (i.e., proof of dates orders were placed) that orders were received by the manufacturer with reasonable lead times.

PART 2 - EQUIPMENT

2.1 GENERAL:

Refer to schedule on Foodservice Drawings and Section 4, Itemized Specifications, included in this Section.

2.2 MATERIALS:

A. Quality Standards for Metals:

1. Stainless Steel: Type 302/304, #4 finish where exposed, 2B finished where not exposed.
2. Steel Sheet: Hot-rolled carbon steel.
3. Galvanized Steel Pipe: Welded or seamless, schedule 40, galvanized or heavier.
4. Steel Structural Members: Hot rolled or cold formed, carbon steel unless stainless steel is indicated.

B. Quality Standards for Plastic Laminates:

1. Comply with current NSF Standards.
2. Applied directly over 3/4" thick close-grained plywood, Grade A/B, or better of selected, smooth, sanded stock to ensure a smooth ripple-free laminated surface. OSB, MDF, or particleboard panels are not considered acceptable. If specified plywood substrate is unavailable, submit specifications and sample of alternate material for approval.
3. Adhere to substrate materials with manufacturer recommended waterproof and heatproof contact cements only.
4. Exposed faces and edges shall be faced with 1/8" thick material. Corresponding backs are to be covered with approved backing material. No unfinished exposed plywood surfaces will be acceptable.
5. All plastic laminate surfaces are to be finished without waves and unsightly joints.
6. Color and texture as selected by the Architect/Interior Designer.

C. Insulation:

1. For low temperature applications, such as ice bins, cold pans, or fabricated under counter freezers or refrigerators, use urethane, rigid board foam, or foamed-in-place; not less than two (2) inches thick, except that vertical surfaces of cold pans and ice bins may be one (1) inch thick. Insulation shall be bonded at joints with urethane or polyurethane expanding foam to fill all voids and prevent condensation on exterior. Polystyrene foam will not be acceptable.
2. For heated type applications, use mineral wool, a minimum of one (1) inch thick.
3. All insulation shall be fully encased, or enclosed.

D. Joint Materials:

1. Sealants: Silicone based, liquid elastomeric sealant, non-solvent release type. Sealants

shall be NSF listed, and FDA approved for use in food zones. Installation shall comply with applicable requirements of NSF Standards.

2. Gaskets: Solid or hollow neoprene or PVC light grey, self-adhesive or prepared for either adhesive application or mechanical attachment.

E. Paints and Coatings:

1. Provide the types of painting and coating materials which, after drying or curing, are suitable for use in conjunction with foodservice and which are durable, non-toxic, non-dusting, non-flaking, mildew resistant, and comply with all governing regulations for foodservice.
2. Sound Deadener: NSF listed sound deadening material, latex sound deadener, for internal surfaces of metal work, and underside of metal counters, dish tables, sink bowls, and drain boards. Install “tacky tape” between work top, and underbracing, or framing.

2.3 FABRICATED COUNTERS, TABLES, AND METAL PRODUCTS:

A. General Fabrication Requirements:

1. Remove burrs from sheared edges of all sheet metal to eliminate cutting hazard. Maintain flat, smooth surfaces without damage to finish.
2. Reinforce metal at locations of hardware and accessory attachments wherever metal is less than 14-gauge thickness or requires mortised or recessed installation. Weld in place on concealed side of work. Reinforcements will not show on finished, exposed surfaces.
3. Exposed screws or bolt heads, rivets, or butt joints filled with solder are not acceptable. Where fasteners are permitted, provide Phillip’s head or oval head machine screws. Cap threads with acorn nuts, unless fully concealed and inaccessible. Provide nuts and lock washers where necessary or indicated. Match fastener material and finish with finish of metal being fastened.
4. Where components of fabricated metal work are indicated to be galvanized or steel and involve welding of the metal, complete the fabrication, and clean all welding slag, then paint with a high-grade aluminum color, rust-preventative spray paint.
5. Welding and Soldering:
 - a. Welding: All welded parts shall be non-porous and free from imperfections, pits, cracks, or discolorations. Stainless steel joints and seams shall be heli-arc welded, ground smooth and polished to a No. 4 finish. Welds of galvanized steel shall be ground smooth.
 - b. Materials 18-gauge or heavier shall be welded. Seams and joints are to be shop welded or soldered as indicated. Welds must be ground smooth and polished to match the original finish.
 - c. Where galvanizing has been burned off, the weld shall be cleaned and then painted with a high-grade aluminum color, rust-preventative spray paint.
6. Provide removable panels for access to mechanical and electrical service connections and components concealed inside equipment, but only where other means of access is not possible and not indicated through other work.

7. Where ends of equipment, rear or end splashes, shelves, etc., are open after fabrication, they are to be enclosed by forming metal and welding, adding filler sections, if necessary, to close entire opening flush to walls, adjacent fixtures, or equipment.
 8. Coved Corners: Stainless steel foodservice equipment shall have a minimum of 1/4" radius coves in horizontal and vertical corners, and intersections, and are to be constructed to NSF standards.
 9. Set each item of non-mobile and non-portable equipment securely in place, level and adjust to correct height. Anchor to supporting substrate where indicated and where required for sustained operation and use without shifting or dislocation. Conceal anchorages where possible. Where indicated or required for safety of equipment operator, anchor equipment to floor or wall. Where equipment is indicated to be anchored to floor, provide legs with adjustable flanged feet. Install two anchors on each foot.
 10. Quality of Work: All work to be of the highest quality in the trade. Field verify all dimensions before fabricating, adjust where necessary to conform to building and job site conditions, neatly fit around pipes, offsets, and other obstructions. Fabricate only in accordance with approved shop drawings.
 11. The approved manufacturers for this section are the following: **Titan Stainless** of Page-land, SC, **Custom Metals** of Whitman, MA, and **SML** of Quebec. All others will be rejected.
 12. All items are to be UL listed and NSF certified. All items must have a visible NSF label on each piece of equipment. If equipment has an electrical component, these items must have a visible UL label in addition to the NSF label.
- B. Metal and Gauges:
1. Unless otherwise indicated in Itemized Equipment Specifications, fabricate exposed metalwork of stainless steel, and fabricate the following components from the gauges of metal as indicated:
 - a. 14-gauge 304 stainless steel with #4 finish for all sinks; drain boards, table and counter tops, reinforcements, gusset plates, and hat channels.
 - b. 16-gauge 304 stainless steel with #4 finish for all wall shelves, under shelves, inserts, trays, single-pan drawers, or door fronts.
 - c. 18-gauge 304 stainless steel with #4 finish for all wall cabinets, table, counter base cabinets, skirting, enclosure panels, trim strips, and corners, double-pan drawer fronts or doors, hoods, ventilators, access panels, or covers.
 - d. Type 304 stainless steel is to be used as the standard construction.
- C. Fabrication Methods:
1. Fabricate metal work surfaces by forming, and welding to provide seamless construction, using welding rods matching sheet metal, or welding on stainless steel using stainless steel filler rods, grinding, and polishing to match surrounding surfaces. Where necessary for disassembly, provide waterproof field joints with gasket and concealed bolting. If field-welded field joint is indicated, provide a straight, smooth, edge.
 2. Reinforce work surfaces at a minimum 24 inches on center in both directions with

galvanized or stainless steel structural members as indicated.

D. Top Construction:

1. All tops, unless otherwise indicated, shall be constructed of 14-gauge stainless steel. Exterior edges not adjacent to walls or other equipment shall be turned down 1 ½" with ½" 45-degree turn in. Tops adjacent to walls shall be turned up 6" with 45-degree angle to wall and down ¾". Tops adjacent to other equipment shall be flanged straight down 2". Sound deadening material shall be provided between frame members and stainless-steel tops.
2. The edges of dish table tops not adjacent to walls shall be turned up 3" and rolled down 1-1/2" with corners bull nosed. Dish table tops adjacent to walls shall be turned up 6" back 2" on a 45-degree angle and down ¾". All horizontal edges and internal corners of dish tabletops shall be covered on a 5/8" minimum radius. Ends of back-splashes shall be closed, welded, ground smooth and polished.
3. Edges of preparation counter tops, with sinks, not adjacent to walls shall have non-spill edge, unless specified otherwise. Preparation counter tops, with sinks, adjacent to walls shall be turned up to 6", back 2" on a 45-degree angle and straight down ¾". All horizontal edges and internal corners of preparation counter tops shall be covered on a 5/8" minimum radius. Ends of backsplashes shall be closed, welded, ground smooth and polished. Backsplashes of counter tops with sinks shall be pierced on 8" centers over sinks.
4. All tops shall be reinforced on the underside with enclosed channels running from front to back with center bracing where required to hold tops flat.
5. Metal tops shall be one-piece welded construction, including joints only where necessary.
6. Fasten tops to supporting frames, cabinet bases, or structural members with stainless steel welded stud bolts and stainless-steel cap nuts.
7. Professionally designed bolt together field joints, trim strip, or other commercial joint material to suit requirements shall be used only where it is specified.
8. Welded Field Joints, where specified, will be welded, ground, and polished to match surrounding surfaces. Excessive distortion from the welding will not be acceptable.

E. Structural Components:

1. Unless otherwise indicated, provide framing of minimum 1-1/4" O.D. round pipe or tubing, with mitered and welded joints and gusset plates, ground smooth. Provide 16-gauge stainless steel tube for exposed or concealed framing.
2. Where indicated, enclosed bracing channels of 1" x 4" x 1" are to be used, of material specified, 14-gauge, and attached to tops as outlined in other sections.

F. Field Joints:

1. For any field joint required because of size of a particular item, use a butt-joint, reinforced with formed angles of same material on underside, attached with stud bolts. If bolt together joint is required, provide with concealed stainless-steel bolts and nuts, with waterproof gasket between angles, and seal with food grade and NSF-listed silicone sealant. If specified as field-welded joint, weld and fill with stainless steel filler rod, grind, and polish to match

surrounding material.

2. Field joints shall be located for practical construction of sizes convenient for shipping and entry into building spaces. All field joints shall be fully continuously welded with the same type of metal, ground smooth and polished to the original finish of the metal.

G. Open Pipe Bases:

1. All open bases shall be constructed of 1-5/8" OD 16-gauge stainless steel tubular uprights and cross braces fully welded together, ground smooth and polished. Top of cross braces shall 12" above floor.
2. Uprights shall be fitted on the floor with adjustable, stainless-steel feet as specified inserted into uprights with inside threads to eliminate any possibility of threading collecting dirt and other matter. The tops of legs shall be fitted into die-stamped fully enclosed stainless-steel gussets welded to the reinforcing channels on the underside of stainless-steel tops.
3. Use stainless steel adjustable bullet feet or stainless steel adjustable flanged feet with mounting holes as indicated. Legs are to be spaced sufficiently close enough together to support the weight of items on top of table or counter, and in no case more than 5'-0" on center.
4. Tables 6'-0" long and under shall have four (4) legs and tables 7'-0" long shall have six (6) legs. Legs on dish tables shall be spaced not more than 5'-0" apart unless specified otherwise.

H. Cabinet Bases and Bodies:

1. All cabinet bodies and bases shall be enclosed with 18-gauge stainless steel. Exterior vertical corners shall be square. Bodies and bases shall be mounted on high sanitary adjustable counter legs with toe kicks unless otherwise noted.

I. Legs & Cross rails:

1. Equipment legs and cross rails shall be 1-5/8" O.D., 16-gauge type 304 stainless steel tubing. Fit legs with stainless steel adjustable bullet feet or stainless steel adjustable flanged feet with mounting holes as indicated. Cross rails are to be notched at end and welded to legs as specified. All welds are to be continuous, ground smooth, and polished to match surrounding material. Tack welds are not acceptable. Where flanged feet are specified, anchor to floor with either expanding, driven in stainless steel pins or stainless-steel lag bolts with expanding anchors as indicated.
2. Stainless Steel Gussets to be 16-gauge stainless steel exterior, to accept 1-5/8"O.D. stainless steel tubing, with Allen set screw for fastening and adjustment. Reinforced with 12-gauge mild steel insert welded in interior. To be welded to framing members as indicated.
3. Legs shall be fastened to equipment with gussets, as follows:
 - a. Sinks to have gussets welded to stainless steel channels, 14-gauge or heavier, anchored to either drain boards, or sink bowls as indicated, with stainless steel welded stud bolt.
 - b. Metal Top Tables and Dish Tables to have gussets welded to stainless steel

channels, unless otherwise indicated, 14-gauge or heavier, anchored to top with stainless steel welded stud bolts.

- c. Wood Top Tables to have gussets welded to stainless steel channels, 14-gauge or heavier, anchored to underside of top with stainless steel screws through slotted holes to allow for top expansion.

J. Casters:

1. Type and size as specified on drawings and specifications, NSF approved, not less than 5" diameter; heavy-duty ball-bearing, solid or disc wheel with non-marking grease proof rubber, neoprene or polyurethane wheel as specified. The minimum width of tread shall be 1-3/16". Minimum weight capacity shall be 250 pounds per caster unless otherwise noted in itemized specifications.
2. Unless otherwise indicated, each equipment item on casters is to be supplied with two (2) swivel-type casters and two (2) swivel-type casters with foot brakes. Brakes are to be on front casters for equipment against walls and on opposing corners of equipment not normally against walls.

K. Shelves:

1. All under shelves and interior shelves shall be constructed of 18-gauge stainless steel.
2. Under shelves on open base tables shall be welded to the legs.
3. Construct solid shelves under pipe base tables of 16-gauge stainless steel, with 1-1/2" turn-down front and ends, bottom edges turned in additional 2" @ 45-degrees, and 1-1/2" turn-up at rear, unless indicated otherwise. Notch and fully welded to pipe legs as necessary, ground smooth and polished to match surrounding material. Tack welds are not acceptable. In fixtures with enclosed bases, turn up shelves at both rear and sides.
4. Interior shelves of cabinet bodies and bases shall be adjustable and removable unless specified otherwise. Sides and rear edges of shelves shall be turned up and front turned down. Shelves shall be braced on the underside. Where plumbing and other appurtenances pass through counter bases, open chases, shall be provided to accommodate piping.
5. Elevated Shelves: All elevated shelves shall be constructed of 16-gauge stainless steel and shall be turned down 1-1/2" with 1/2" 45 degree turn in on front and ends. Freestanding shelves, unless specified otherwise, shall be mounted on 1 5/8" OD stainless steel tubular uprights mounted to counter tops.

L. Sinks:

1. All sinks shall be constructed of 14-gauge stainless steel having back, bottom and front formed of one (1) continuous sheet of metal with ends and partitions welded in place. All vertical and horizontal corners of sink compartments shall be coved with metal on a 5/8" (minimum) radius. Bottom of sinks are to be creased and pitched toward drains.
2. Sink inserts shall be constructed the same as specified for sinks above with coved corners. Sink inserts shall be welded integral with stainless steel tops. Fully fabricated 14-gauge Stainless Steel construction. Deep Drawn or stamped bowls are not acceptable. Sink

bottoms are to be creased and pitched toward drains.

3. Partitions to be double thick, 1" minimum space between walls. Multiple compartments shall be continuous on the exterior with stainless steel apron.
4. Cove interior vertical and horizontal corners of each tub not less than 5/8-inch radius, die formed. Outer ends of drain boards have roll rim risers not less than 3 inches high.
5. Punch rear splashes with holes for faucets as indicated 2-1/2" below top edge. Verify center-to-center spacing with faucet specified.

M. Plumbing Fixtures:

1. Where exposed or semi-exposed, provide piping in bright chrome plated brass or polished stainless steel and copper where not exposed. PVC is not acceptable for cold water drains (ice bins, soda fountains, condensate from refrigeration) unless they were allowed by local codes. PVC is not acceptable on any drains where hot water will flow or for pressured water lines.
2. Vacuum Breakers: Provide with foodservice equipment items where specified.
3. Unless otherwise indicated, furnish lever or twist waste drains as specified on all sinks, with removable flat strainers and 2" IPS outlet size. If basket drains are specified, will be all stainless-steel construction.
4. Handle (lever or twist, as specified) to extend to front edge of sink. Handle to be supported and protected by stainless steel bracket where indicated. No riveting, screws, or soldering permitted to fit drains to sinks, with all parts of drains easily removable for servicing and replacement.
5. Water pans for hot food tables shall be fitted with 1" drains with chrome-plated brass stand-pipes or manifolded together to a single gate valve for draining as indicated.
6. All faucets furnished with equipment included in this Section shall comply with current NSF and Lead-Free Standards. No lead products are acceptable on this project and need to conform to lead testing per NYSOCCRR sub part 67-4. When the itemized specifications list a faucet by manufacturer and model, the Contractor shall verify that the listed faucet complies with this requirement. If the listed faucet does not comply, the Contractor shall notify Foodservice Consultant immediately and submit for approval a similar model, which does comply, from the same manufacturer where possible. Provide mounting kit for all splash mounted faucets to the plumber for installation. Mounting kits depend on faucet requirements.

N. Electrical Materials and Components:

1. Provide standard materials, devices and components as recommended by the manufacturer or fabricator, selected, and installed in accordance with NEMA standards and recommendations as required for safe, efficient use, and operation.
2. Components shall bear the UL label, or be UL recognized, with the whole item being UL listed.
3. Confirm all electrical requirements for project, including but not limited to, actual voltages available, single, or three-phase availability, etc.

4. Electrical work for custom fabricated equipment shall be completely pre-wired to a junction or pull box mounted on the equipment, all wires clearly marked and labeled for outlet or item served. Counters should be wired for a single connection point at the job site wherever possible and specified. Verify local requirements for UL Listing on complete assembly and provide if required.
5. Custom fabricated refrigeration units shall be provided with vapor proof light fixtures with shatterproof polycarbonate lamp shields and automatic switches. All wiring shall be concealed if possible.
6. Controls, Switches, and Receptacles: Provide recognized commercial grade signal lamps, switches, controls, and switches as indicated. All such units to be complete with pilot lights, permanent signs, and graphics to assist the user of each item. Provide stainless steel cover plates on all electrical boxes and switches; these are always to be located out of heat zones, easily accessible, and in locations that prevent accidental contact by staff.
7. Convenience Outlets and Power Receptacles:
 - a. Make cutouts and install appropriate boxes or outlets in fabricated fixtures complete with wiring, conduit, outlet, and stainless-steel cover plate.
 - b. GFCI outlets shall be furnished where adjacent to sink compartments as per the National Electrical Code.
8. Plugs and Cords: Where cords and plugs are provided, they shall comply with National Electrical Manufacturers Association (NEMA) requirements. Indicate NEMA configuration for each applicable item.
9. Heating Equipment:
 - a. Electric heating equipment should be so installed as to be readily cleanable or removable for cleaning.
 - b. Steam heated custom fabricated equipment shall be a steam coil/heat exchanger design, and will include all necessary control valves, components, and moisture traps located and shall be installed and located in an accessible position.
10. Motors are to be enclosed type, except drip-proof type where not exposed to dust or moisture condition. Ball bearings or sleeve bearings are acceptable on small-timer motors; moisture resistant windings, horsepower, and duty-cycle ratings as indicated.
11. Internal Wiring of Fixtures and Equipment:
 - a. The FSEC shall be responsible for internal wiring of electrical devices built into fabricated equipment items. Wiring is to be enclosed in metal conduit or an electrical chase where indicated, to an accessible pull-box, with all wires clearly labeled. For any item shipped in sections, all wiring shall be properly connected internally to a single connection point and verified by the FSEC.
 - b. Furnish dishwashers, and conveyors internally wired to junction boxes, or distribution panel as specified, including all required switches, motors, immersion heaters, solenoids, and other components required for proper operation.
 - c. Where light fixtures are specified or detailed as part of counters, cases, or fixtures; light fixtures, lamps, and shields shall be furnished and installed. If fluorescent light

fixtures are specified, warm white lamps are to be used unless otherwise specified and ballasts shall be included. Shatter shields shall be provided for all light fixtures.

- d. All wiring shall conform to the National Electrical Code and shall be UL listed.
- e. Exposed flexible steel conduit on kitchen equipment shall be neoprene jacketed Seal-Tite conduit equal to Anaconda type UA/UL approved, complete with approved liquid-tight connectors on each end and designed to provide electrical grounding continuity.
- f. Exposed electrical conduit used in kitchen wet area applications, except for flexible connections, shall be rigid galvanized steel. Thin wall conduit (EMT) shall not be permitted for wet areas. Exposed outlet boxes shall be liquid-tight type, with threaded hubs.

O. Enclosures:

- 1. Provide enclosures, including panels, housings, skirts, trim panels, operating components, mechanical, and electrical devices associated with the food service equipment unless specifically indicated otherwise.

P. Doors:

- 1. Metal doors shall be double-cased stainless steel, 18-gauge with corners welded, ground smooth and polished. The inner pan shall be fitted tightly into outer pan with a sound-deadening material such as Styrofoam used as a core. The two pans shall be tack welded together, and joints sealed. Door thickness to be 3/4".
- 2. Wood doors are to be constructed as detailed. If Formica or other plastic surfaces are used, sides and backs must be laminated as specified on plans or specifications.
- 3. Hinged Door Hardware: Hinged doors shall be mounted with heavy duty NSF approved hinges with pulls. Catches shall be heavy-duty magnetic type, unless otherwise indicated.
- 4. Sliding Door Hardware: Sliding doors shall be mounted on large, quiet ball bearing rollers with quiet nylon wheels in 14-gauge stainless steel overhead tracks. Rollers to be easily replaceable and doors to be removable without the use of tools (lift out).
- 5. All hardware used must be identified with the manufacturer's brand name, and part number on shop drawings so that broken or worn parts may be easily obtained and replaced.

Q. Drawer Assemblies:

- 1. Assemblies shall consist of removable drawer body mounted in a ball bearing slide assembly with fully enclosed housing. Slide assembly consists of one pair of 200-pound capacity, 300 series stainless steel, full extension, side-mounting, self-closing type, with stainless steel ball-bearings and positive stops. Drawers have side and back enclosure panels, front spacer angle, two drawer carrier angles, secured to slides and stainless-steel front. Drawer pulls shall be stainless steel full grip type with frame beveled edge.
- 2. Unless otherwise indicated, drawers for general storage are to have a removable 20"x 20" x 5" deep stainless-steel pan. Drawers intended to hold food products are to be designed to hold standard 12" x 20" stainless steel food pans up to 4" deep in a stainless-steel assembly.

3. Drawer fronts are double-pan construction, $\frac{3}{4}$ " thick, and 18-gauge stainless steel, welded, ground, and polished. The back pan is tightly in-fitted, tack welded and sealed. Sound deadened with rigid insulation material.
 4. Provide drawers with replaceable soft neoprene bumpers or, for refrigerated drawers, a full perimeter soft gasket.
- R. Sound Deadening:
1. Sound deaden underside of metal tops, drain boards, under shelves, cabinet interior shelves, etc., above the underbracing, reinforcing, or framing only.
 2. Sound Deadener: NSF listed sound deadening material, latex sound deadener for internal surfaces of metal work, and underside of metal counters, dish tables, sink bowls, and drain boards. Install "tacky tape" between work top, and underbracing, or framing.
- S. Serving Counter Fabrication:
1. Tops are a minimum of 14-gauge 300 series stainless steel with not less than a #4 finish with 2" square turndown on all sides. Corners are fully welded and polished. The tops are attached to the cabinet body so that no spot weld marks appear.
 2. Cabinet bodies are heavy gauge 300 series stainless steel panelized construction, 14-gauge stainless steel vertical channel supports at all tray slide bracket locations and additional galvanized channel supports as per detail shown below.
 3. Starting at the base of the unit, the unit shall have a 2" high x minimum 4" wide, 14-gauge galvanized supports running from front to rear at each leg location. Located left to right on back of the shelf nosing and across the rear of the unit are approx. $\frac{1}{2}$ " x 2" galvanized supports. All the base bracing shall be closed off to prevent vermin from entering.
 4. Inside the unit behind the end mullion, there are 20-gauge galvanized inserts to match the width of the mullion and close off any gaps. Should the unit have a work shelf on the operator side a 14-gauge backer should be installed, so that any screws to hold the shelf in place are penetrating the 14-gauge backer.
 5. In the inside rear of the unit, there are to be minimum 4" wide "C" Shaped 14 gauge 300 series stainless steel vertical supports, installed at each end of the unit, and where any attachment is made for tray slide, additional supports shall be installed vertical so that the spacing from center to center does not exceed 16" inches. Across the top of the vertical support and around the perimeter of the top, unit shall have $\frac{1}{2}$ " x 2" 20 gauge "C" shaped supports. Unit top shall have top support where needed.
 6. All open shelf areas shall be the full width and depth of the base area. No cavities shall be created in the construction of the body that is not accessible without the use of tools.
 7. All supports and body panels shall be welded together in unitized or panelized body construction.
 8. All units include a 300 series stainless steel built-in under shelf with utility access holes and grommeted black covers. Intermediate under shelves where required are welded in position. Under shelf shall run the full distance of the unit, less the material thickness of the end panels and shall be full depth, less the material thickness of the back panel.

9. Casters are secured to a 2" x 4", minimum 14 gauge galvanized inverted channel that runs front to back.
10. The cabinets may have a choice of stainless steel or powder coated material as determined by the consultant or architect. If a powder coat is chosen, then galvanized will be used in lieu of stainless steel in the construction of the base.
11. Exterior finish can be a choice of plastic laminate veneered to body panels, removable laminated panels, powder coat paint finish, or a variety of millwork options as specified.
12. All powder coat painting must be conducted in-house at the approved manufacturer's facility to ensure quality control.
13. Tray Slides: Before fabrication of counters with tray slides, verify size and shape of tray to be used. Edge of tray shall not overhang outer support/slider by more than 2". If the edge of tray exceeds this dimension, notify Architect, in writing, for evaluation and adjustment if necessary. Tray slide to be capable of supporting 300 pounds per linear foot, live load.
14. All equipment must bear labeling and be approved by the U.L. for safety and sanitation and must be built in an ISO 9001:2000 approved manufacturing facility. Compliance with the National Sanitation Foundation's (NSF) standards 2, 4 and 7 shall be confirmed by U.L. Sanitation or other nationally known and respected third-party testing facilities.

2.4 REFRIGERATION:

A. General:

1. All refrigerant and associated components shall comply with the latest code requirements and shall comply with the latest Federal Regulations for energy efficiency. Walk-In coolers or freezers need to include the following: automatic door closing device, power air curtains on doors, heated triple pane windows on cooler and freezer doors, high efficiency lighting or automatic light switches, R-25 insulation in cooler walls, doors, and ceilings, R-32 insulation in freezer walls, doors, and ceilings, and R-28 insulation in walk-in cooler and freezer floors. Condensing units shall be equipped with PSC fan motors and evaporator fans shall utilize the ECM type fan motors. Refrigerants must comply with the latest type required by Federal Regulations and use R290 refrigerant where possible.
2. Wiring for walk-in refrigerator and freezer cabinets shall be UL approved type from exterior junction boxes to internal components, with insulation, unless local codes require metallic conduit (EMT or Greenfield). For freezer applications, Seal-Tite Flex or approved equal shall be used. Lighting receptacles, and door switches shall be mounted weatherproof boxes. All penetrations to be insulated with expanding foam and sealed to prevent condensation moisture buildup.
3. Furnish either single, or multiple condensing units, or a rack refrigeration system as specified and/or recommended by the manufacturer for the items on the equipment schedule. Furnish all components necessary for a complete installation of the system, including coils, receivers, compressors, motors, motor starters, mounting bases, vibration isolation units, fans, dryers, valves, piping, insulation, gauges, winter control equipment, etc.
4. All refrigerant and associated components shall comply with the latest code requirements. No CFC refrigerants or associated components shall be allowed on this Project. HFC refrigerants and components shall be used where available. HCFC refrigerants and components, with a minimum 2010 phase-out date and intermediate replacement refrigerants, are to be used only when HFC refrigerants are not available.

5. The minimum outdoor operating ambient temperature for design of units is -10 degrees Fahrenheit, unless otherwise specified. The maximum indoor design temperature for operation of compressor units is 95 degrees Fahrenheit. The maximum outdoor ambient design temperature shall not be less than 100 degrees Fahrenheit. Special attention is to be given to conditions at mounting locations of condensing units, such as sun exposure, restricted air flow and ventilation, fences, walls, roof color, and materials.

B. Components:

1. Expansion Valves: Remote refrigeration system shall be complete with thermostatic expansion valves at the evaporator coils.
2. Thermometers: Fabricated refrigerated compartments to be fitted with either flush dial or digital thermometers as specified on individual items. Thermometers shall be adjustable and calibrated after installation. Accuracy to be +/- 2 degrees Fahrenheit.
3. Hardware: Refrigerator hardware for fabricated refrigerator compartments shall be heavy-duty components, NSF Listed. Use self-closing, heavy duty edge mount style hinges, with Spring Kit. Latches to be magnetic edge mount type, with cylinder locks, unless specified or detailed otherwise. All doors and drawers for walk-in coolers/freezers and reach-in refrigerated compartments, both fabricated and standard shall be fitted with cylinder locks.

C. Cold Pans:

1. Ice pans, refrigerated pans, and cabinets shall be provided with breaker strips or other insulation where adjoining top or cabinet face materials to prevent transfer of cold and possible condensation problems.
2. All open top mechanically cooled custom fabricated, standard buy-out refrigerators, and / or cold pans shall comply with the latest NSF Standard #9 requirements.

D. Refrigerated Equipment Ventilation:

1. Adequate ventilation shall be provided for custom fabricated equipment with integral refrigeration condensing units, both built-in and drop-in. If flow through ventilation cannot be provided, provide flow direction partitions and an additional fan capable of cooling the condensing unit. If in the opinion of the Food Service Equipment Contractor or Refrigeration Subcontractor additional room ventilation is required to ensure correct operating temperatures of standard buy-out, custom fabricated, remote refrigeration condensing units, or compressor rack assemblies, they shall so state in a letter to the Architect for evaluation and decision.

2.5 MISCELLANEOUS:

- A. Reasonable quietness of operation of equipment is expected, and the Foodservice Contractor will be required to replace or repair any equipment producing excessive noise at no expense to the owner. This includes but is not limited to bumpers and gaskets for doors and drawers, and sound deadening or insulation where specified and practical.
- B. Manufactured Equipment Items: Furnish items as scheduled or herein specified. Verify dimensions, spaces, rough in, and service requirements, as well as electrical characteristics before ordering. Provide trim, accessories, and miscellaneous items for complete installation.
- C. Nameplates: Whenever possible, locate nameplates and labels on manufactured items in an

accessible position, but not within the normal view of customers.

- D. All items must have a visible NSF label on each piece of equipment. If equipment has an electrical component, these items must have a visible UL label in addition to the NSF label.

PART 3- EXECUTION

3.1 SITE EXAMINATION:

- A. Verify site conditions under the provisions of the General Conditions, Supplementary Conditions, and applicable provisions of other Sections. Notify the Architect, in writing, of unsatisfactory conditions for proper installation of foodservice equipment specified in this section.
- B. Verify that all required service utilities are available, and of the correct characteristics in the required locations. Notify the Architect, in writing, of any problems or conflicts with food service equipment specified in this section.
- C. Verify wall, column, door, window, and ceiling locations and dimensions. Fabrication and installation should not proceed until dimensions and conditions have been verified and coordinated with fabrication details.
- D. Verify that necessary wall reinforcement or backing has been provided for wall-mounted equipment. Coordinate with General Contractor for placement of such backing during wall construction.
- E. Verify that ventilation ducts are of the correct characteristics and in the required locations.

3.2 SUPERVISION:

- A. A competent supervisor employed by the Food Service Equipment Contractor shall be always present during progress of the FSEC's work.
- B. A competent supervisor employed by the Food Service Equipment Contractor shall be always present during work by any of the FSEC's subcontractors.

3.3 SITE CLEANUP:

- A. Throughout the progress of their work, the Food Service Equipment Contractor shall keep their working area free from debris, and shall remove all trash, rubbish, etc., daily. At no time is the FSEC to allow any trash, debris, rubbish, crating, boxes, packaging, etc. to accumulate at the job site. At the completion of their work, the FSEC shall leave the premises in a clean and finished condition.

3.4 INSTALLATION:

- A. Sequence installation and erection to ensure correct mechanical and electrical utility connections are achieved. Install items as per each manufacturer's installation manual.
- B. Set each item of non-mobile and non-portable equipment securely in place, leveled, and adjusted to correct height. Anchor where indicated and where required for sustained operation and use without unnecessary movement. Conceal anchors wherever possible. Adjust counter tops and other work surfaces to a level tolerance of (+/-) 1/16" or better.
- C. Complete field assembly joints in all by welding, bolting / gasketing or as otherwise indicated and specified. Grind all welds smooth and restore the finish to match surrounding materials as specified.

- D. Provide anchors, supports, bracing, clips, attachments, etc., as required to comply with the local seismic restraint requirements.
- E. Verify, and coordinate mounting heights of all wall shelves and equipment with equipment located below for proper clearances.
- F. Insulate contact points between dissimilar metals to prevent electrolysis. Cut, punch, and drill components for outlets, fixtures, piping, conduit, and fittings as required. Coordinate with other trades and provide holes in food service equipment for plumbing and electrical service to and through the fixtures as required or indicated. This includes welded sleeves, collars, ferrules, or escutcheons. These services are to be located so that they do not interfere with intended use, and / or servicing of the fixture.
- G. Provide sealants and gaskets around each unit to make joints airtight, waterproof, vermin-proof, and sanitary for cleaning purposes. At internal corner joints, apply sealant or gaskets to form a sanitary cove. The shape exposed surfaces of sealant slightly concave. Sealant filled or gasketed joints will be acceptable up to 3/8" joint width. Wider joints are to be provided with a matching metal closure or trim strip with sealant application to each side of strip.

3.5 ADJUSTING:

- A. Repair or replace equipment that is found to be defective in its operation, including units that are operating with excessive noise or vibration.
- B. Test and adjust equipment, controls, and safety devices to ensure proper working order and conditions.

3.6 CLEANING AND RESTORING FINISHES:

- A. Restore damaged finishes, polish exposed metal surfaces, and touch-up painted surfaces. Replace work, which cannot be successfully restored.
- B. After completion of installation, and completion of other major work in foodservice areas, remove all protective coverings, films, etc., and clean foodservice equipment.
- C. Clean and polish glass, plastic, hardware, accessories, fixtures, and fittings and leave in a condition ready for the owner to sanitize and use.

3.7 EQUIPMENT START-UP, TESTING, AND DEMONSTRATION:

- A. Prior to final connections by other trades, the Food Service Equipment Contractor is responsible for inspecting and verifying the readiness of all utilities. FSEC to coordinate a site meeting with all trades required to review and approve all rough-in and accessory items that meet the equipment requirements per the manufacturer's recommendations. A written report shall be submitted by the FSEC to the architect and/or consultant.
- B. The Food Service Equipment Contractor is to test and start up **all** equipment prior to the equipment demonstration. Any problems should be addressed prior to the training, and a written report should be submitted by the FSEC to the architect and/or consultant.
- C. The Food Service Equipment Contractor is to plan for a demonstration of food service equipment operation and maintenance in advance with the owner / operator. This training session for all equipment should be provided on one day or a few consecutive days pending approval by the owner/operator. Demonstrate all equipment to familiarize the owner / operator with operation and

maintenance procedures including periodic preventative maintenance measures required. Include an explanation of service requirements, and simple on-site service procedures as well as information concerning the name, address, and telephone number of a qualified local source of service. The individual performing the demonstration should be knowledgeable of the operating and service aspects of the equipment. The FSEC shall provide a written attendance sheet for all attendees including owner/operator, FSEC representative, and all equipment demonstrators. Failure to provide this submittal will hinder the closeout of the project.

PART 4 - ITEMIZED SPECIFICATIONS:

ITEM: 100

QUANTITY: 1

MANUFACTURER: TRUE MANUFACTURING

MODEL: TMC-49-SS-HC

DESCRIPTION: MILK COOLER

Mobile Milk Cooler, forced-air, (12) 13" x 13" x 11-1/8" crate capacity, stainless steel drop front/hold-open flip-up lid with lock, 33 - 38°F temperature range, (3) heavy-duty floor racks, digital thermometer, white vinyl exterior, stainless steel interior and floor, 4" casters, self-contained R290 Hydrocarbon refrigerant, 1/5 HP, UL and NSF Listed.

- 120/60/1
- Exterior digital thermometer
- Seven-years parts and labor warranty
- Seven-year compressor warranty

ITEM: 101

QUANTITY: 1

MANUFACTURER: DUKE MANUFACTURING

MODEL: TST-74SS / WW-4

DESCRIPTION: HOT FOOD STATION

Thurmaduke Four Section Hot Food Unit, 34" high counter, 14-gauge stainless steel top, unit with reinforced cut-out for (4) waterless hot food units built into the unit, individual thermostats, stainless steel enclosed cabinet body, casters with brakes, stainless-steel legs with adjustable feet, and locking device with stainless pin and latch under one end of the counter top.

- 120/208/60/1
- Exterior laminate on cabinet front and exposed exterior. Laminate background panel color to be selected by the architect.
- 10" Solid stainless-steel tray slide with 2 rub rails, mounted to be an integral part of the cabinet on fixed brackets with a rear turn up on tray slide.
- The tray slide is mounted at 30" AFF and has an internal locking device with stainless steel pin and latch line up device mounted under tray slide.
- 1" Recessed top for sheet pans
- Model #WW-4 Waterless hot food well drop -in unit, electric, dry operation with no drain, (4) 12" x 20" hot food wells, stainless steel well, removable FDA approved black silicone rubber liner, fully insulated exterior housing, individual touch screen control panel, (3) pre-set temperatures, Wi-Fi enabled, UL and NSF listed.
- Storage compartment on operator's side without center shelf

- Expressions style IBC station with electrical cord cover
- Mounted body pilasters on front and rear of serving lines between units that join.
- Stainless steel adjustable kickplate to be mounted with stainless steel fasteners ½" above the floor. Stainless steel pilaster shall be used behind the gaps in the units, so the kick plates appear to be continuous. Kick plates are removable for movement of unit and mounted on the front and milk cooler side of the unit.
- (6) Vollrath Model #30042, Super Pan V Food Pan, full size, 4" deep, 14-quart capacity, 22-gauge, 300 series stainless steel, reinforced pour corners, reverse formed flattened edges, anti-jamming design, NSF, Made in USA.
- (6) Vollrath Model #30022, Super Pan V Food Pan, full size, 2 ½" deep, 22-gauge, 21-quart capacity, 300 series stainless steel, reinforced pour corners, reverse formed flattened edges, anti-jamming design, NSF, Made in USA.
- (6) Vollrath Model #77250, Super Pan V Steam Table Pan Cover, stainless, full size, reinforced flat solid, fits all full-size pans, NSF.
- (6) Vollrath Model #30242, Super Pan V Food Pan, 1/2 size, 4" deep, 6.7-quart capacity, 22-gauge, 300 series stainless steel, reinforced pour corners, reverse formed flattened edges, anti-jamming design, NSF, Made in USA.
- (6) Vollrath Model #30222, Super Pan V Food Pan, 1/2 size, 2 ½" deep, 10-quart capacity, 22-gauge, 300 series stainless steel, reinforced pour corners, reverse formed flattened edges, anti-jamming design, NSF, Made in USA.
- (6) Vollrath Model #75120, Super Pan V Steam Table Pan Cover, stainless, 1/2 size, reinforced flat solid, fits all half-size pans, NSF.

ITEM: 102

QUANTITY: 1

MANUFACTURER: DUKE MANUFACTURING

MODEL: TS422-74

DESCRIPTION: BREATH GUARD

Contemporary field shield, adjustable from full-service to self-service, single shelf, vertical and fixed end enclosures, stainless steel finished posts mounted through countertop with mounting flange, 3/8" glass over-shelf and guard, and ½" glass ends. All glass is tempered and polished with rounded edges.

- Led light mounted under the shelf, wired to a switch on the counter.
- Verify breath guard post finish/color with architect and owner.
- No center post to the counter top will be permitted. Span the entire unit without center support.

ITEM: 103

QUANTITY: 1

MANUFACTURER: DUKE MANUFACTURING

MODEL: TST-74SS / HCF-2

DESCRIPTION: HOT/COLD FOOD STATION

Thurmaduke Hot/Cold Food Station, two section, 34" high counter, 14 gauge stainless-steel top, stainless steel enclosed cabinet body, reinforced cut out for drop-in, mechanical hot and cold section convertible unit, partial length open under-storage with hinged stainless steel louvered compressor compartment, 1" drain line and valve extended through bottom shelf, casters with brakes and stainless steel legs with adjustable feet, and locking device with stainless pin and latch under both ends of counter top.

- 120/60/1

- Reinforced cut out for drop-in equipment.
- Exterior laminate on cabinet front and exposed exterior. Laminate background panel color to be selected by the architect.
- 10" Solid stainless-steel tray slide with 2 rub rails, mounted to be an integral part of the cabinet on fixed brackets with a rear turn up on tray slide.
- The tray slide is mounted at 30" AFF and has an internal locking device with stainless steel pin and latch line up device mounted under tray slide.
- Expressions style IBC station with electrical cord cover
- Mounted body pilasters on front and rear of serving lines between units that join.
- (1) Model HCF-2 Hot, Cold, Freeze Combination Pan, drop-in, heated and refrigerated, (2) 12" x 20" pan capacity, 300 series stainless steel interior liners, independent electronic controls, individual wired remote digital controls for hot or cold operation, stainless steel top and well, steel exterior housing, fully insulated galvanized exterior housing air cooled self-contained refrigeration, 1" drain extended through cabinet base, and UL and NSF listed.
 - Flush mounted pans
 - Dry heat wells with silicone liners
 - One-year parts and labor warranty
 - Five-year compressor warranty
- Provide a compressor compartment with hinged louvered door panel and provide proper ventilation for compressor. Louvered door should have a magnetic catch on the top and the bottom of the door panel.
- On / Off Switch on apron wired to units and lights to be located without removing louvered panel.
- Stainless steel adjustable kickplate to be mounted with stainless steel fasteners 1/2" above the floor. Stainless steel pilaster shall be used behind the gaps in the units, so the kick plates appear to be continuous. Kick plates are removable for movement of unit and mounted on the front and milk cooler side of the unit.

ITEM: 104

QUANTITY: 1

MANUFACTURER: DUKE MANUFACTURING

MODEL: TS422-46

DESCRIPTION: BREATH GUARD

Contemporary field shield, adjustable from full-service to self-service, single shelf, vertical and fixed end enclosures, stainless steel finished posts mounted through countertop with mounting flange, 3/8" glass over-shelf and guard, and 1/2" glass ends. All glass is tempered and polished with rounded edges.

- Led light mounted under the shelf, wired to a switch on the counter.
- Verify breath guard post finish/color with architect and owner.

ITEM: 105

QUANTITY: 1

MANUFACTURER: DUKE MANUFACTURING

MODEL: TST-74SS / FCP4-SB

DESCRIPTION: COLD FOOD STATION

Thurmaduke Cold Food Station, four section, 34" high counter, 14 gauge stainless-steel top, stainless steel enclosed cabinet body, reinforced cut out for drop-in, stainless steel mechanical four section cold pan, partial length open under-storage with hinged stainless steel louvered compressor compartment, 1" drain

line and valve extended through bottom shelf, casters with brakes and stainless steel legs with adjustable feet, and locking device with stainless pin and latch under both ends of counter top.

- 120/60/1
- Reinforced cut out for drop-in equipment.
- Exterior laminate on cabinet front and exposed exterior. Laminate background panel color to be selected by the architect.
- 10" Solid stainless-steel tray slide with 2 rub rails, mounted to be an integral part of the cabinet on fixed brackets with a rear turn up on tray slide.
- The tray slide is mounted at 30" AFF and has an internal locking device with stainless steel pin and latch line up device mounted under tray slide.
- Expressions style IBC station with electrical cord cover
- Mounted body pilasters on front and rear of serving lines between units that join.
- (1) Model #FCP-4-SB Cold food unit, 4 well drop-in unit, accommodates (4) 12" x 20" stainless steel cold refrigerated pans, stainless steel top with overhang and locking tabs, fully insulated galvanized exterior housing, digital touch screen control panel, Wi-Fi enabled, air-cooled condensing unit, (4) individually controlled cold wells, flush mounted wells, 1" drain extended through cabinet base, 72" control wire, includes spacing rim, UL and NSF listed.
 - Flush mount wells
 - Condensate Evaporator
 - Five-year compressor warranty
- Provide a compressor compartment with hinged louvered door panel and provide proper ventilation for compressor. Louvered door should have a magnetic catch on the top and the bottom of the door panel.
- On / Off Switch on apron wired to units and lights to be located without removing louvered panel.
- Stainless steel adjustable kickplate to be mounted with stainless steel fasteners 1/2" above the floor. Stainless steel pilaster shall be used behind the gaps in the units, so the kick plates appear to be continuous. Kick plates are removable for movement of unit and mounted on the front and milk cooler side of the unit.
- (6) Vollrath Model #30042, Super Pan V Food Pan, full size, 4" deep, 14-quart capacity, 22-gauge, 300 series stainless steel, reinforced pour corners, reverse formed flattened edges, anti-jamming design, NSF, Made in USA.
- (6) Vollrath Model #30022, Super Pan V Food Pan, full size, 2 1/2" deep, 22-gauge, 21-quart capacity, 300 series stainless steel, reinforced pour corners, reverse formed flattened edges, anti-jamming design, NSF, Made in USA.
- (6) Vollrath Model #77250, Super Pan V Steam Table Pan Cover, stainless, full size, reinforced flat solid, fits all full-size pans, NSF.
- (6) Vollrath Model #30242, Super Pan V Food Pan, 1/2 size, 4" deep, 6.7-quart capacity, 22-gauge, 300 series stainless steel, reinforced pour corners, reverse formed flattened edges, anti-jamming design, NSF, Made in USA.
- (6) Vollrath Model #30222, Super Pan V Food Pan, 1/2 size, 2 1/2" deep, 10-quart capacity, 22-gauge, 300 series stainless steel, reinforced pour corners, reverse formed flattened edges, anti-jamming design, NSF, Made in USA.
- (6) Vollrath Model #75120, Super Pan V Steam Table Pan Cover, stainless, 1/2 size, reinforced flat solid, fits all half-size pans, NSF.

ITEM: 106

QUANTITY: 1

MANUFACTURER: DUKE MANUFACTURING

MODEL: TS422-74

DESCRIPTION: BREATH GUARD

Contemporary field shield, adjustable from full-service to self-service, single shelf, vertical and fixed end enclosures, stainless steel finished posts mounted through countertop with mounting flange, 3/8" glass over-shelf and guard, and 1/2" glass ends. All glass is tempered and polished with rounded edges.

- Led light mounted under the shelf, wired to a switch on the counter.
- Verify breath guard post finish/color with architect and owner.
- No center post to the counter top will be permitted. Span the entire unit without center support

ITEM: 107

QUANTITY: 1

MANUFACTURER: DUKE MANUFACTURING

MODEL: TCS-30SS

DESCRIPTION: CASHIER STATION

Thurmaduke Solid Top Unit, 36" high counter, stainless steel counter top, individual thermostats, stainless steel enclosed cabinet body with partial under shelf, stainless steel tube foot rest, stainless-steel legs with adjustable feet, cabinet bodies to be bolted together in the field and common top installed and seamed as required.

- 120/60/1 with cord and plug wired to (2) Duplex outlets in the base.
- Exterior laminate on cabinet front and exposed exterior. Laminate background panel color to be selected by the architect.
- (2) 10" Solid stainless-steel tray slide with 2 rub rails, mounted to be an integral part of the cabinet on fold-down brackets with a rear turn up on tray slide.
- The tray slide is mounted at 30" AFF and has an internal locking device with stainless steel pin and latch line up device mounted under tray slide.
- Cash drawer with stainless steel face and frame with stainless liner on roller slides, with lock and black pull handle
- 2 3/4" Round cut out with grommet.
- (2) Duplex NEMA #5-20R Receptacles with cover, mounted in the base of cashier section and a CAT5e data box for the POS system.
- Stainless steel adjustable kickplate to be mounted with stainless steel fasteners 1/2" above the floor. Stainless steel pilaster shall be used behind the gaps in the units, so the kick plates appear to be continuous. Kick plates are removable for movement of unit and mounted on the front and side of the unit.

ITEM: 108

QUANTITY: 1

MANUFACTURER: STERIL-SIL

MODEL: TC-8

DESCRIPTION: SILVERWARE DISPENSER

Countertop Silverware Dispenser, 8-hole, 20" x 11 1/2" x 8 1/2" tall, portable, fits Steril-Sil silverware cylinders or 30 oz. containers, non-marking feet, 304 stainless steel, NSF.

- (16) Model #S-500 High-Capacity Silverware Cylinder, fit a 4-1/32" cutout, perforated, beveled lip, straight-walled, footed base, 18-gauge, 304 stainless steel, electro-polish finish, NSF.

ITEM: 109

DESCRIPTION: SPARE NUMBER

ITEM: 110

DESCRIPTION: SPARE NUMBER

ITEM: 111

QUANTITY: 1

MANUFACTURER: STERIL-SIL

MODEL: CRT36-OTC

DESCRIPTION: TRAY CART

Open top tray cart, all welded, enclosed stainless-steel construction on three (3) sides with open front, (4) corner bumpers, locking and non-marking casters, and integrated handle grasps, and NSF listed,

- (4) Locking casters

ITEM: 112

QUANTITY: 1

MANUFACTURER: TRUE MANUFACTURING

MODEL: STR1H-1S

DESCRIPTION: HEATED CABINET

Heated Cabinet, reach-in, one-section, (1) stainless steel door with lock, cam-lift hinges, digital temperature control, (1) interior kit, stainless steel front and sides, stainless steel interior, 5" castors,

- 208/60/1
- Kit#1 (9) Sets of universal pan slides and pilasters with bottom support
- Right Hand Door Hinging
- Seven-year compressor warranty
- Seven-years parts and labor warranty
- Lifetime warranty on door hinges

ITEM: 113

QUANTITY: 1

MANUFACTURER: CAPTIVE-AIRE

MODEL: 6024ND-1

DESCRIPTION: EXHAUST HOOD

The ND-2 series is a Type I, wall canopy hood for use over 450°F/600°F cooking surface temperatures. The manufacturer assumes no liability for the use or results of use of this document. Specifications are to be reviewed by the engineer to confirm the project's requirements and meet Federal, State, and Local codes and regulations. As the manufacturer continues product development, it reserves the right to change design and specifications without notice. The manufacturer shall supply complete computer-generated submittal drawings, including hood section view(s) and hood plan view(s). These drawings must be available to the engineer, architect, and owner for their use in construction, operation, and maintenance.

This hood is ETL-listed to standard UL710, ULC710, and ULC-S646 when installed in accordance with

these installation instructions and National Fire Protection Association Standard “NFPA 96, Standard for Ventilation Control and Fire Protection of Commercial Cooking Operations.” Built-in compliance with NSF/ANSI Standard 2. Approved for use in New York City per the Fire Department of New York Certificate of Approval #5804. The hood shall be ETL Listed as:

- “Exhaust Hood Without Exhaust Damper.”
- ETL Sanitation Listed and built in accordance with NFPA 96.
- The ETL label shall list temperature rating(s) and minimum CFM/ft rating(s).

All units shall be provided with the following standard warranty: this equipment is warranted to be free from defects in materials and workmanship, under normal use and service, for a period of 2 years from the date of shipment. The manufacturer shall not be liable for incidental and consequential losses and damages potentially attributable to malfunctioning equipment. Should any part of the equipment prove to be defective in material or workmanship within the 2-year warranty period, upon examination by the manufacturer, such part will be repaired or replaced by the manufacturer at no charge. The buyer shall pay all labor costs incurred in connection with such repair or replacement. Equipment shall not be returned without the manufacturer’s prior authorization, and all returned equipment shall be shipped by the buyer, freight prepaid to a destination determined by the manufacturer.

Construction shall be dependent on structural application to minimize distortion and other defects. All seams, joints, and penetrations of the hood enclosure to the lower outermost perimeter, which directs and captures grease-laden vapor and exhaust gases, shall have a liquid-tight continuous external weld in accordance with NFPA 96. Duct sizes, CFM, and static pressure requirements shall be shown in the drawings. Static pressure requirements shall be precise and accurate; air velocity and volume information shall be accurate within 1-ft increments along the length of the ventilator.

- Construction shall be type 430 stainless steel.
- Double wall insulated front to eliminate condensation and increase rigidity on wide sizes. The insulation shall have a flexural modulus of 475 EI, meet UL 181 requirements and be in accordance with NFPA 90A and 90B.
- Hood should be equipped with a minimum of four connections for hanger rods. Hood lengths greater than 12’ will have added hangers.
- Exhaust duct collar to be 4” high with flange.
- The grease drain system shall be an enclosed integral part of the hood back and have slopes with an exposed, removable 1/2 grease cup to facilitate cleaning.
- Removable grease cup for easy cleaning.
- Hood shall be furnished with UL classified filters, supplied in size and quantity as required by ventilator.
- All seams shall be welded and have stainless steel on exposed surfaces.
- Recessed round LED fixture and LED light, 3500K Warm output.
- Stainless Steel Captrate Solo filter with hook, ETL Listed. Particulate capture efficiency: 85% efficient at 9 microns, 76% efficient at 5 microns.
- Wall Mounted Utility Cabinet – The cabinet can store listed fire suppression system, listed components, and pre-wired electrical controls.

The Electrical Package is designed to thermostatically activate the exhaust fans for an exhaust hood whenever elevated temperatures are sensed in the exhaust system. This option will meet the requirements of IMC 507.2.1.1 by providing a thermostat(s) mounted in the duct or hood riser to sense increased exhaust temperatures.

Controls shall be listed by ETL (UL 508A). The control enclosure shall be NEMA 1 rated and listed for installation inside of the exhaust hood utility cabinet. The control enclosure may be constructed of stainless steel or painted steel.

Temperature probes(s) located in the duct riser shall be constructed of Stainless Steel.

Once the duct temperature reaches the activation point, the exhaust fans will be activated. The controls also provide hysteresis to prevent cycling of the fans after the cooking appliances have been turned off and the heat in the exhaust system is reduced. The hysteresis is factory set 2 degrees and will keep the exhaust running until the temperature falls 2 degrees below the activation set point. A hysteresis timer also exists to keep the fans running for at least 30 min after being activated by the temperature rise.

The activation and hysteresis settings may be field adjusted on the board LCD interface located inside the control enclosure to meet application needs.

The panel is factory configured to shut down supply fans, turn on the exhaust fans, and turn off the hood lights in a fire condition. Examine areas and conditions under which the system is installed. Do not proceed with work until unsatisfactory conditions have been corrected in a manner acceptable to the Installer. Install in accordance with manufacturer's instructions, drawings, written specifications, manufacturer's installation manual, and all applicable building codes.

The wall backsplash panels are to be aesthetically pleasing and span between hood and floor and the length of the unit including the fire cabinet. Wall panels to be constructed with the same material, finish, and grain as the hood. Panels should go behind the hood at a minimum of two (2) inches, and the hood should be sealed to the wall. FSEC is responsible for providing cut-outs in the stainless panels to accommodate any utilities coming out of the wall under the hood. Include divider bars and end trim for securing wall paneling to wall.

Provide closure panels constructed with the same material as the hood to close off space between the top of hood and ceiling as required for field installation.

Exhaust fans are to be coordinated with the CFM requirements of the hood.

Note: Exhaust and supply fans are to be provided and installed by a separate contractor and are to be coordinated with the CFM and power requirements of the unit.

The hood shall be both UL and NSF rated per the most current codes and regulations.

FSEC is responsible for verifying and coordinating the exhaust duct riser location with the ceiling joists and all other site conditions.

ITEM: 114

QUANTITY: 1

MANUFACTURER: CAPTIVE-AIRE

MODEL: TANK-SP-2-WC

DESCRIPTION: FIRE SUPPRESSION SYSTEM

TANK Fire Suppression is a pre-engineered, stored pressure wet chemical solution extinguishing system. A pre-engineered, fixed pipe, automatic wet chemical agent fire suppression system for protection of all hazard areas associated with cooking operations, including exhaust hoods, plenums, ductwork, and cooking appliances.

- The TANK Fire Suppression System is ETL Listed in accordance with ANSI/CAN/UL/ULC 300, ULCORD-C 1254.6
- The microprocessor-based control board shall be ETL Listed to UL Standard 864 and CAN/ ULC-S527-11.
- TANK Fire Suppression System intended for installation and for use in accordance with the National Fire Protection Association Standards:
- Wet Chemical Extinguishing Systems, NFPA 17A

- National Electrical Code, NFPA 70
- National Fire Alarm & Signaling Code, NFPA 72
- New York City and FDNY approved under COA# 5870.
- California State Fire Marshal (CFSM), Listing No. 7085-2199:0502.

All units shall be provided with the following standard warranties:

- TANK Fire Suppression System is warranted to be free from defects in materials and workmanship, under normal use and service, for a period of 60 months from date of shipment.
 - The warranty does not cover consumable products such as batteries and nitrogen.
 - The manufacturer shall not be liable for incidental and consequential losses and damages potentially attributable to malfunctioning equipment. Should any part of the equipment prove to be defective in material or workmanship within the 60-month warranty period, upon examination by the manufacturer, such part will be repaired or replaced by the manufacturer at no charge. The buyer shall pay all labor costs incurred in connection with such repair or replacement. Equipment shall not be returned without the manufacturer's prior authorization, and all returned equipment shall be shipped by the buyer, freight prepaid to a destination determined by the manufacturer.
 - Exhaust hood fire system components to be factory installed.

Cylinder and Valve Assembly

- The cylinders shall have a tin-nickel alloy plated brass valve with pressure gauge.
- Wet chemical agent shall be contained in one or more stored pressure DOT/TC rated steel cylinder and valve assemblies.
- Each cylinder is factory-filled with liquid fire suppressant and pressurized to 200 PSIG at 70°F.
- Maximum cylinder flow points = 20.

Distribution Nozzles

- Nozzles shall be located to protect the exhaust ducts, plenums, and all cooking appliances requiring protection.
- All nozzles shall be equipped with a metal blow off cap. The cap prevents contamination from entering the pipe network and is designed to pop-off upon system discharge, allowing agent to flow to the protected hazard area.
- All nozzles shall incorporate a stamped part number to easily identify nozzle type.

Distribution System

- The distribution system shall consist of Copper, Schedule 40 black iron, chrome-plated or stainless-steel pipe and fittings. All exposed piping and fittings must be chrome-plated or stainless steel.
- Fittings shall be minimum class 150. Galvanized fittings shall not be used.

Suppression System

- The system control equipment shall be capable of all functions associated with automatically and manually discharging the wet chemical agent from all cylinder and valve assemblies, including automatic shutdown of the heat source or fuel and electrical power to all protected areas upon system discharge.
- Liquid Fire Suppressant shall be Aqueous Potassium Carbonate (APC).
- All mechanical components of the actuator kit shall be enclosed.
- The actuator kit shall be capable of automatic or manual activation means.
- Supervisory Pressure Switch added to monitor operating system pressure.
- For manual activation, an electrically operated manual release shall be used to actuate the system manually.
- For automatic activation, the system will be activated by a Firestat (heat) detector.

Electrical:

- Printed circuit board with microprocessor-based controller that provides all the necessary

monitoring, timing, and supervision functions required for the reliable operation of the fire system.

- Independent supervised loops incorporate redundancy and fault detection.
- Real-time cloud-based monitoring connection provided with system by ownership.
- Primary power supply, with battery backup for power loss.
- All wiring must be in accordance with NFPA 70 and the Authority Having Jurisdiction(AHJ).
- All wiring is to be in accordance with the applicable manufacturer's instructions for the fire alarm control panel, manual reset relay, and contractor supplied shut-off devices.

Wet chemical-based fire suppression system for use in commercial kitchens. It can be mounted in the A stainless steel cabinet located on the wall as shown on the drawings.

As part of this item, provide wall mounted type K handheld portable fire extinguisher, placard, and mounting bracket as required in the immediate vicinity of each cooking area, per NFPA-96 and NFPA-10. Additional fire extinguishers, as required in the kitchen area, are to be specified by the Architect and provided by the General Contractor. Install in accordance with manufacturer's instructions, drawings, written specifications, manufacturer's installation manual, and all applicable building codes. Six-month and twelve-month inspections, servicing, and replacement of components as per NFPA 96 to be provided by the General Contractor or Owner.

Micro-switches for electrical equipment shut off and/or actuation of fire alarm system shall be furnished as part of the fire protection system by the manufacturer and connected to the shunt trip provided and installed by the Electrical Contractor. The Electrical Contractor is to furnish and install a control relay to detect the operation of the system by connection to the Micro switches supplied by the Fire Protection System Contractor. The Electrical Contractor is to interface with the building alarm system and/or the fire command station and the micro switches.

All access openings, holes, sleeves, chases, etc. in the building structure necessary to permit piping and control tubing to be run between system unit, ventilator, and ductwork are to be provided by the General Contractor.

ITEM: 115

QUANTITY: 1

MANUFACTURER: RATIONAL

MODEL: ICP 6-FULL ON 6-FULL E

DESCRIPTION: DOUBLE COMBINATION OVEN

Two iCombi Pro 6-full size combination ovens, double stack, Rational intelligent connectable cooking system with four assistants: iDensity Control, iCooking Suite, iProduction Manager, and iCare System, full-size, electric, cooking controls with 6 operating modes, (5) cooking methods, (3) manual operation modes: combi-Steamer, Convection Oven, or Combination. Each oven has a capacity of (6) 18"x26" or (12) 12"x20" pan capacity, core temp probe with 6-point measurement, 85° to 572°F temperature range, hand shower with automatic retracting system, comes with (3) grid shelves, quick clean, care control, eco mode, ethernet interface and Wi-Fi interface, NSF and UL listed.

Provide the following:

- 208/60/3
- Energy Star
- Requires ethernet connection.
- The door is to be hinged on the right
- Rational Certified Installation with Pre-Installation Site Survey, including stacking kit and installation of stacking kit, water filter system, and commissioning.

- F.S.E.C. is responsible in coordination with Rational, for providing water samples or test results from a recent water sample.
- Water Filtration Double Cartridge System with (2) additional cartridges
- Certified installation of water filter system.
- Certified Chef training
- Mobile oven stand on adjustable height casters, with stacking kit and safety set
- Installation Kits
- (6) Stainless steel grid shelves with K-12 promotion
- (6) Fry Baskets with K-12 promotion
- Fully automatic cleaning system including delimiting of the steam generator.
- AutoDose System for integrated autonomous cleaning which includes (2) Cleaner Cartridges and (2) Care Cartridges
- (2) Box of 6 Cleaner Cartridges
- (2) Box of 6 Care Cartridges
- Condensation breaker
- USB data memory stick
- Positioning aid for core temperature probe
- Two-year parts and labor warranty
- Five-year steam generator warranty
- (12) Vollrath Model #9002P, Wear-Ever Sheet Pan, full size, 18"wide x 26"deep x 1"high, 18-gauge aluminum alloy, natural finish, perforated, Made in USA.
- (12) Vollrath Model #30023, Super Pan V Food Pan, perforated, full size, 2-1/2" deep, 22-gauge, 300 series stainless steel, anti-jamming design with reinforced pour corners, NSF, Made in USA.

ITEM: 116

QUANTITY: 1

MANUFACTURER: IMPERIAL

MODEL: ITG-36-E

DESCRIPTION: GRIDDLE

Griddle, countertop, electric, 36" wide x 24" deep cooking surface, 1/2" thick polished steel griddle plate, (4) thermostatic controls with heat protection grip, continuous pilot, aeration baffles, 4" wide grease gutter, removable 1 gallon grease can with weep hole, full width rear flue, stainless steel front, sides, splash guard, and ledge, UL and NSF listed.

- 208/60/3
- 4" stainless steel adjustable legs
- One-year limited parts and labor warranty

ITEM: 117

QUANTITY: 1

MANUFACTURER: TRUE MANUFACTURING

MODEL: TRCB-36-HC-SPEC3

DESCRIPTION: REFRIGERATED EQUIPMENT STAND

Refrigerated Chef Base, 36" wide base, includes: one-piece 300 series 18-gauge stainless steel top with V edge, (2) drawers with locks, accommodates (1) 12" x 20" x 4" pans & (3) 1/6 size pans, stainless steel front, sides and back, stainless steel interior, self-contained R290 Hydrocarbon refrigerant, 1/4 HP, UL and NSF Certified

- 120/60/1
- 4" stem casters with brakes
- Seven-year compressor warranty
- Seven-years parts and labor warranty
- (6) Vollrath Model #30042 Super Pan V Food Pan, full size, 4" deep, 14-quart capacity, 22-gauge, 300 series stainless steel, reinforced pour corners, reverse formed flattened edges, anti-jamming design, NSF, Made in USA.
- (6) Vollrath Model #30642 Super Pan V Food Pan, 1/6 size, 4" deep, 1.8 qt capacity, 22-gauge, 300 series stainless steel, reinforced pour corners, reverse formed flattened edges, anti-jamming design, NSF, Made in USA.

ITEM: 118

QUANTITY: 1

MANUFACTURER: IMPERIAL

MODEL: IHR-6-E

DESCRIPTION: RANGE

Spec Series Heavy Duty Range, electric, 36", (6) sealed round elements, solid top, (1) standard oven with high performance 5.3 kw element, baffle heat flow with heat deflector, heavy duty door hinge, (1) chrome rack, splatter screen, infinite heat controls, porcelain oven interior, stainless steel front, sides, backguard, landing ledge, and kick plate, 6" legs with adjustable feet, ETL and NSF listed.

- 208/60/3
- 6" Stainless steel stub back
- Additional oven rack
- One-year parts and labor warranty
- Made in the USA

ITEM: 119

DESCRIPTION: SPARE NUMBER

ITEM: 120

DESCRIPTION: SPARE NUMBER

ITEM: 121

QUANTITY: 1

MANUFACTURER: TITAN STAINLESS

MODEL: FS-WT3096-US-OS-PR

DESCRIPTION: WORK TABLE

Work Table shall be custom built as per General Specifications, approximately 8'0" x 2'6" x 34" high to work surface, 14-gauge 304 stainless steel top with square edge, 6" high backsplash with fully enclosed ends. Provide two (2) GFCI #5-20R receptacles mounted in the backsplash, which is to be factory installed and wiring is to be concealed and connected into a junction box mounted underneath the under shelf or in a chase. Provide two (2) 20"x 20" x 5" stainless steel drawers with lock on anti-slam slides with 1/2" Richlite cutting board mounted under the drawer. The cutting board shall have a handle slot to easily remove the boards from under the drawer. Provide stainless steel gussets and legs with flanged feet on

front ends, bullet feet on balance, full-length stainless steel under shelf with a 2" rear up-turn. The under-shelf is to be extended and attached to the undershelf on Item #122. Provide common top/end caps to fasten Item #121 and #122 to appear as one unit.

- Provide table mounted, 12" deep solid over shelf with a 2" rear upturn. The rear flange of the shelf is to be fastened to Item #122 over shelf with stainless steel fasteners.
- Provide table-mounted oval pot rack, two tiers with center utensil rack, and (25) pot hooks.
- Seal shelf posts to backsplash on the table.
- Flanged feet on front corner legs only.
- Secure flanged feet to the floor with stainless steel fasteners.
- Fasten and seal Item #121 to Item #122 with stainless steel fasteners.

ITEM: 122

QUANTITY: 1

MANUFACTURER: TITAN STAINLESS

MODEL: FS-PT3096-US-OS

DESCRIPTION: PREP TABLE

Work Table shall be custom built as per General Specifications, approximately 8'0" x 2'6" x 34" high to work surface, 14-gauge 304 stainless steel top with marine edge, 6" high backsplash with fully enclosed ends. Provide 18" x 20" x 14" deep sink bowl with removable bowl cover, with a cover holder mounted under the countertop between the sink bowl and the legs, lever waste and bracket, and a 12" plumbing chase from directly under the sink to the floor to conceal the supply lines. This chase shall have a removable access panel. Provide one (1) 20"x 20" x 5" stainless steel drawer with lock on anti-slam slides with 1/2" Richlite cutting board mounted under the drawer. The cutting board shall have a handle slot to easily remove the boards from under the drawer. Provide stainless steel gussets and legs with flanged feet on front ends, bullet feet on balance, and a full-length stainless steel under shelf under the entire unit with a 2" rear up-turn and drain access. The undershelf is to be extended and attached to the undershelf on Item #121. Provide common top/end caps to fasten Item #122 and #121 to appear as one unit.

- Provide table mounted, 12" deep solid over shelf with a 2" rear upturn. The rear flange of the shelf is to be fastened to Item #121 over shelf with stainless steel fasteners.
- Seal shelf posts to backsplash on the table.
- Flanged feet on front corner legs only.
- Secure flanged feet to the floor with stainless steel fasteners.
- Fasten and seal Item #122 to Item #121 with stainless steel fasteners.
- (1) T&S Brass Model #B-0221-CR4-L22, Mixing Faucet, double, deck mount, 8" adjustable center, 12" swing nozzle with 2.2 GPM laminar flow device (062X-L22), lock washer included, quarter-turn Cerama cartridges with check valves, 4" wrist action handles with color coded indexes, 1/2" NPT female inlets, polished chrome-plated brass body, low lead content, ADA Compliant.
 - (1) T&S Model #B-0425-M Supply Nipple Kit, includes one (1) 1/2" NPT x 2" long inlet supply nipple, one (1) 1/2" locknut washer and one (1) 1/2" locknut, brass (2 each per master pack)
 - (2) Model #017420-45 24" flex supply hoses
- (1) T&S Brass Model #B-3970-01, Waste Valve, lever handle, 3 1/2" sink opening, 2" drain outlet with 1 1/2" adapter and overflow assembly.

ITEM: 123

QUANTITY: 1

MANUFACTURER: TRUE MANUFACTURING

MODEL: T-49-HC

DESCRIPTION: REACH-IN REFRIGERATOR

Refrigerator, reach-in, double section, (2) self-closing stainless-steel doors with removable magnetic door gaskets, (3) PVC coated adjustable wire shelves per door section, LED interior lighting, stainless steel front, aluminum sides, aluminum interior, stainless steel floor with coved corners, foamed-in -place high density polyurethane foam insulation throughout, 4" castors, welded heavy duty steel frame rail, R290 Hydrocarbon refrigerant with bottom mounted condensing unit, 1/2 HP, UL and NSF listed.

- 120/60/1
- Right Door: Full door of universal tray slides to hold (1) full sheet pan or (2) full hotel pans with bottom support.
- Left Door: (4) Wire Shelves
- Stainless steel finished back
- Self-contained refrigeration
- 4" stem casters with brakes
- Seven-year compressor warranty
- Seven-years parts and labor warranty
- Lifetime warranty on door hinges

ITEM: 124

QUANTITY: 1

MANUFACTURER: ADVANCE TABCO

MODEL: 7-PS-91

DESCRIPTION: HAND SINK

Hand Sink, wall model with pedestal base, approximately 14" x 10" x 5" sink bowl with inverted "V" edge, 8" integral backsplash, 20-gauge, #304 stainless steel all welded construction, one (1) hole for splash-mounted faucet, 6" apron, includes hands free electronic faucet, basket drain, mounting bracket and clip with hardware, and NSF listed.

- Model #7-PS-10 P-Trap Assembly
- Electronic Faucet, splash type, gooseneck, with metering/check valve.
- Full length sink apron.
- Front Access Panel
- Mount and seal to the wall
- Coordinate with P.C. to make sure utilities and censored faucet components fit within the stainless-steel enclosure provided with the sink.

ITEM: 125

QUANTITY: 1

MANUFACTURER: TITAN STAINLESS FABRICATORS

MODEL: FS-TCS30123-US-OS

DESCRIPTION: THREE COMPARTMENT SINK

Three Compartment Sink shall be custom built as per General Specifications, approximately 10'3" x 2'6" x 34" high to work surface, 14-gauge 304 stainless steel top with raised rolled edge and rounded corners, provide an 10" rear backsplash with enclosed ends, (3) 20"x 28" x 16" deep sink bowls with continuous front, lever waste handle bracket for lever waste and overflow, stainless steel under shelf with 2" up-turn at rear and ends mounted under the left drain board, open front with cross rails under the right drainboard

for garbage can, balance of the unit to have cross rails with stainless steel gussets, legs, and flanged feet on front corner legs with bullet feet on rear and centers.

- Provide (2) 12" deep louvered wall shelves with 2" rear upturn, tight to the wall.
 - Verify mounting height with owner.
 - Coordinate wall backing with General Contractor
- Coordinate over shelves with pre-rinse faucet.
- Lever-waste and overflow to be installed by sink manufacturer.
- Secure flanged feet to the floor with stainless steel fasteners
- Seal unit to the wall
- (1) T&S Brass Model #B-0133-12CR-BJ-ST, Easy-Install Pre-Rinse Unit, 8" wall mount, add on faucet 12" swivel nozzle, Cerama cartridges with check valves, lever handles, 18" riser, 44" flexible stainless-steel hose, 1.07 GPM, accessory fitting, wall bracket, low lead, NSF (B-0230-K).
 - (2) Model #B-WH4 Wrist Action Handles, 4"
 - (2) Model #012534-45 24" flex supply hoses
- (1) T&S Brass Model #B-0221-CR4-L22, Mixing Faucet, double, deck mount, 8" adjustable center, 12" swing nozzle with 2.2 GPM laminar flow device (062X-L22), lock washer included, quarter-turn Cerama cartridges with check valves, 4" wrist action handles with color coded indexes, 1/2" NPT female inlets, polished chrome-plated brass body, low lead content, ADA Compliant. o Model #B-0425-M Supply Nipple Kit, includes one (1) 1/2" NPT x 2" long inlet supply nipple, one (1) 1/2" locknut washer and one (1) 1/2" locknut, brass (2 each per master pack)
 - (2) Model #017420-45 24" flex supply hoses
- (3) T&S Brass Model #B-3970-01 Waste Valve, lever handle, 3 1/2" sink opening, 2" drain outlet with 1 1/2" adapter and overflow assembly.

ITEM: 126

QUANTITY: 1

MANUFACTURER: METRO

MODEL: MX-G SERIES

DESCRIPTION: POT & PAN RACK

Each unit consists of four (4) posts, four (4) shelves, and four (4) locking casters.

- (4) Model #MX2448G Metro-Max I Shelf, 48" wide x 24" deep, removable open grid polymer mats with Microban antimicrobial protection, reinforced type 304 stainless steel corners, wedge connectors with quick adjust corner releases, NSF.
- (4) Model #MX70UP Metro-Max I Post, 70" high, open pole for use with stem casters, polymer construction with built in Microban antimicrobial product protection, NSF.
- (4) Model #5PCBX Stem Caster, brake, 5" diameter, polyurethane wheel tread with donut bumpers.
- (2) Model #XTR2448XE Cutting Board and Tray Drying Rack System thirty-four (34) tray capacity, 6" up-rights with 1 1/8" spacing, mounts on 48" wide x 24" deep frame, taupe epoxy, NSF.
- (1) Model #XTR2448XEa Cutting Board and Tray Drying Rack System fourteen (14) tray capacity, 6" up-rights with 3" spacing, mounts on 48" wide x 24" deep frame, taupe epoxy, NSF.
- (1) Model #XDRIP Adjustable drip tray. Provide removable drip pan as part of this item.
- (1) Vollrath Model #8002410, Super Pan 1/1 Food Pan, 2 1/2" deep, low-temp polycarbonate clear plastic, top flange corners with concave indentation, anti-jamming, ramped sides, reverse form flattened edge, framing shoulder, interchanges with SPV stainless steel pan line, NSF, made in USA.
- The bottom three shelves hold the drying rack. (1) with the 3" spacing and (2) with the 1 1/8" spacing.
- Verify shelf spacing with owner.

ITEM: 127

QUANTITY: 1

MANUFACTURER: TITAN STAINLESS

MODEL: FS-WT3060-US

DESCRIPTION: WORK TABLE

Work Table shall be custom built as per General Specifications, approximately 5'0" x 2'6" x 34" high to work surface, 14-gauge 304 stainless steel top with square edge, 6" high backsplash with fully enclosed ends. Provide stainless steel gussets and legs, bullet feet, full-length stainless steel under shelf with a 2" rear up-turn.

- Coordinate wall receptacles with backsplash and over shelf height.

ITEM: 128

QUANTITY: 1

MANUFACTURER: ACP/AMANA

MODEL: HDC10Y15

DESCRIPTION: MICROWAVE OVEN

Amana Commercial Microwave Oven countertop, compact, 1000 watts, 0.6 cu. foot capacity, accommodates standard half-size pan, (2) magnetrons, stackable, X2 quantity pad, 4-stage cooking, (11) power levels, (100) memory settings, auto voltage sensor, smart USB connectivity, ACP Programming compatible, multi-language operation, side hinged door, grab and go door handle, removable air filter, LED interior light, stainless steel interior and exterior, ETL and NSF listed.

- 120/60/1

ITEM: 129

DESCRIPTION: SPARE NUMBER

ITEM: 130

DESCRIPTION: SPARE NUMBER

ITEM: 131

QUANTITY: 1

MANUFACTURER: ARTIC INDUSTRIES

MODEL: 222064

DESCRIPTION: WALK-IN COOLER/FREEZER

General –The overall size of the walk-in box shall be approximately 14'2" x 7' 2" x 8'6 ¼" Tall. The cooler and freezer compartment interior dimensions are as shown in the drawings. Verify size and shape as shown on the plan. Walk-ins shall be constructed of prefabricated modular panels manufactured by Arctic Industries, Miami, Florida. All insulated panel structures to be set up at factory prior to shipment, checked for structural and quality accuracy, photographed prior to shipment. They shall be designed for easy and accurate field assembly, future enlargement by the addition of panels, or dismantling should relocation to an alternate site be desired. Construction shall be in strict compliance with NSF Standard 7 and UL. This unit shall be provided with internal ramps to create a smooth transition between the walk-in floor and the building floor.

Panel Construction - All panels shall consist of interior and exterior metal surfaces precision roll formed to exact dimensions with double 90° edges to enhance overall panel rigidity. The finished metal surfaces shall be fitted with a teardrop profile gasket and placed in precision-tooled fixtures where they are injected with Foamed-in-Place urethane insulation. Curing of the insulating core shall take place at a controlled temperature within the foaming fixture to provide permanent adhesion to the metal surfaces, to allow uniform foam expansion and to maximize finished panel strength. Panel edges shall have a molded urethane tongue and groove profile of insulation factor equal to core material to accurately align panels during installation and to assure an airtight seal. No structural wood, steel, straps, or other non-insulating materials shall be used in panel construction. Finished panels must be UL classified building units and each should bear the Underwriters Laboratory label.

Finished panels will be 4" thick and will be provided in 11 ½", 23", 34 ½" and 46" widths to conform to project drawings. Corner panels shall be one piece 90° angled construction and shall measure 12" x 12" or 12" x 6 ½" where required. For units with multiple compartments, specially designed "Tee" panels shall be provided to form partition wall to outside wall junctures. "Tee" panels shall measure 23" x 12" or 23" x 6 ½" where required. All panels shall be interchangeable with like panels or standard doorframe sections for fast and easy assembly.

Floor Construction – Where prefabricated floor panels are required, they shall be of similar design to other panels and shall incorporate a fully die formed ¼" NSF coved radius at all interior floor to wall junctures. Floor panels shall be reinforced with ¾" exterior grade plywood and shall be capable of supporting evenly distributed loads up to 1300 pounds per square foot or more. Floor to be smooth aluminum with non-skid strips in the aisle ways.

Door Construction - Entrance doors are constructed like other panels and shall be flush mount, magnetic in-fitting type. Door sections shall be constructed to conform to Underwriters Laboratories Standards for electrical safety and shall bear all appropriate UL listing labels. The perimeter of the door and frame shall be built of a fiberglass reinforced plastic (FRP) pultrusion weighing not less than 8.4#/lineal foot. All pultrusion's shall be non-conductive, non-corrosive, rust proof and listed by the National Sanitation Foundation. Doorjamb shall house a doorframe heater circuit, and a magnet attracting stainless steel trim strip. The doorframe shall be equipped with flexible bellows type vinyl door gasket with magnetic core, and flexible EPDM (ethylene propylene diene monomer) door sweep. Standard door frame sections 46", 57 ½" or 69" wide shall be equipped with a LED vapor proof light fixture and globe pre-wired to a rocker type light switch with pilot light. An aluminum braided heater wire with integral circuit closure providing activation while the refrigerated room is within operating temperature and a 14-gauge stainless steel threshold plate shall also be included in all door frames.

The door hardware shall be die cast zinc with brushed satin finish. Doors shall be mounted with three (3) heavy-duty cam lift hinges. The pull handle assembly shall incorporate a keyed cylinder lock and an inside safety release handle to prevent personnel entrapment. A hydraulic closer device shall assist positive door closing and sealing.

Walk-In Monitoring System Modularm 75LC: System to have an easy-to-read LCD display with high and low alarm set points with audible and visual alerts for alarm conditions. The system shall include Auto set Technology for automatic set point control. The system should have an integrated, push-button light switch with on/off indicator light. The system shall comply with the latest federal energy requirements by incorporating an automatic lighting shut-off. The system shall be supplied with dry contacts for connection to equipment that requires dry contacts such as building monitoring systems, dialers, etc. A magnetic contact, MC-1, shall be installed on the door for auto light feature and door "open" monitoring. The system to be supplied with an interior press button light switch and panic alarm with constant burning backlight, IP-1. The system should include a Motion detector, MD-1, to reset the light timer when motion is present. Both digital displays should be in the exterior entrance door panel frame when one or more doors are on a partition wall.

Doors to be:

Exterior entrance doors, 36" x 78" (swing as shown on drawing) to include:

- Stainless steel interior and exterior
- Door Closer
- Door Kick plate, 1/10" aluminum tread plate, 36" High on interior and exterior of each door
- Cam lift hinges (3)
- Deadbolt key/padlock handle with inside safety release
- Magnetic gasket
- Single Sweep gasket
- Switch with pilot light
- Monitoring System
- 14"x 24" Vision Window, heated

Finishes - The interior and exterior finish on all panel surfaces may be manufactured from any combination of the following premium grade aluminum or steel materials. The gauge or thickness of the metal material listed is rated prior to embossing.

- Exposed Exterior walls: 22-gauge stainless steel diamond embossed .
- Interior walls and interior ceilings: 26-gauge embossed white stucco coating
- Unexposed: 26-gauge galvanized stucco embossed

Insulation - Insulation shall be 4" thick high-pressure impingement mixed (HPIM) foamed-in-place urethane, minimum density of 2.4 pound per cubic foot, fully heat cured, and bonded to metal finishes. The insulation shall be manufactured using HCFC-141b expanding agent, which has an ozone depletion rating of 0.1 and a global warming rating of 0.05. The thermal conductivity ("K" factor) shall not exceed 0.133 BTU/Hour/Square Foot/Degree Fahrenheit/Inch of Thickness across the entire width of the panel. Overall coefficient of heat transfer ("U" factor) shall not exceed .033 and the resistance to heat penetration ("R" factor) shall not be less than 30. The insulation shall have a 97% closed cell structure to prevent absorption of liquids. The finished aluminum panel (not just the core material) shall be listed by Underwriters Laboratories as a Class 1 (UL-723) building material and demonstrate a flame spread rating of 20 or less and smoke developed of 350 or less in accordance with ASTM-E84 Standards. This rating is not intended to reflect hazards presented by this or any other material under actual fire conditions. Foam used shall be Factory Mutual listed.

Panel Assembly - Assembly of Walk-In shall be accomplished using cam-action locking mechanisms precisely positioned along the outside tongue or groove edges of each panel to exactly correspond with a matching mechanism in the adjacent panel. Cam lock spacing on vertical joints shall not exceed 46" and at junction of vertical and horizontal joints by 23". Cam locks shall be foamed-in-place and anchored securely in the panel by steel "wings" integral to the lock housing. Cam locks shall be operated through access ports using a hex wrench, thereby pulling the panels together and establishing an airtight seal. All access ports shall be located on the walk-in interior to facilitate assembly when close to building structures and shall be covered by vinyl snap-in caps after final assembly. Complete step-by-step assembly instructions, and erection drawings shall be supplied by the manufacturer.

Walk-In Accessories for each compartment:

- (1) LED 17" Light fixture per compartment, high output, for low temperature applications in cooler and freezer
- (1) LED Vapor-proof light in each door frame
- (1) Power air curtain with backing on exterior of cooler: Berner Model #SLC-07-1036A-SS complete with cord and plug for receptacle built into the door panel.
- Non-skid strips (in aisles only)
- Exposed exterior with 1/10" aluminum tread plate, with bumper-rail mounted at top of kick plate. Top of bumper should be 36" AFF.
- Exterior corners of building walls to be sealed with full-height stainless steel closure strips.
- Provide stainless steel closure panels between walk-in and ceiling.

- Provide a vapor barrier between the concrete slab and the walk-in-floor panels. (Typically, a 15-pound asphalt paper with a 4" overlap at all seams). Verify with manufacturers installation instructions. Provide documentation and photos as proof of installation.
- Heated pressure relief port on freezer sections

Warranty - Insulated panel products are to be warranted for a period of ten (10) years after the date of installation for the original user should the panels be installed properly and be used under normal service conditions. After an inspection authorized by the manufacturer, should any part of the product prove to be defective in material or workmanship, it will be repaired or replaced free of charge, F.O.B. factory. This warranty does not apply to accessories or components supplied but manufactured by other companies who furnish their own warranties.

F.S.E.C. shall provide an installation workmanship warranty for three (3) years from the date of installation.

All refrigeration equipment shall comply with the Federal Regulations for energy efficiency. Walk-In coolers or freezers need to include the following: automatic door closing device, strip curtains on hinged doors, heated triple pane windows on cooler and freezer doors, high efficiency lighting or automatic light switches, R-25 insulation in cooler walls, doors, and ceilings, R-32 insulation in freezer walls, doors, and ceilings, and R-28 insulation in walk-in cooler and freezer floors.

Prior to turning on refrigeration systems, F.S.E.C. to "test" the walk-in boxes to verify they are air tight. A smoke test, flood light test, or other means of similar testing is required. If an air-tight test is not performed, the K.E.C. will provide a letter of workmanship warranty for a period of five (5) years covering any defects or air leaks in the walk-in unit.

ITEM: 132 & 133

QUANTITY: 1

MANUFACTURER: ARTIC INDUSTRIES or RDT POLAR CRAFT

MODEL: RFON060M4ADA / RAL6A081ADA

DESCRIPTION: WALK-IN COOLER REFRIGERATION

Walk-In cooler will be provided with a condensing unit and evaporator for refrigerated equipment in accordance with ASHRAE standards. All systems shall be supplied with complete controls for a working system. Each system shall consist of a new condensing unit suspended on a structural steel base with cover and winter controls.

Condensing units shall be preassembled remote, scroll type, air-cooled units for outdoor installation with matching evaporator. Condensing units shall be equipped with PSC fan motors and evaporator fans shall utilize the ECM type fan motors. All refrigeration equipment shall comply with the Federal Regulations for energy efficiency. Refrigeration systems are to be located on the roof of the building. Curb and wind restraints are to be provided and installed by others. Coordinate location with Architect and General Contractor.

Medium temperature unit shall utilize R-454a refrigerant. The manufacturer calculates heat loads and provides systems with a minimum of 105% of needed capacity to maintain holding temperature 35° F in coolers. Calculations shall take into consideration box ambient, refrigeration system ambient, airflow, and exposure to sunlight and altitude. Interconnection of refrigeration lines, insulation, and electrical wiring shall be accomplished by the appropriate trades and shall be a portion of the Kitchen Equipment Contract.

The refrigeration system on the walk-in will be equipped with the Eco-Smart on-demand de-frost controller factory mounted to the evaporator coil(s). The Eco-Smart will be custom designed for refrigeration systems to control the electric expansion valve in response to true evaporator superheat and return air temperature.

Power wiring for the evaporator coils will be provided by the E.C. as required. Off cycle and electric defrost is also available. Provide heater as required so product does not freeze.

Additionally, a refrigeration system containing an Eco-Smart controller will consist of the following factory-mounted parts:

- Electronic controller board with three-digit LED and push button panel interface for setup
- Three solid state temperature sensors
- Pressure transducer
- External relay to control liquid line solenoid valve or compressor contactor
- Electric expansion valve
- 24V transformer

The Eco-Smart board will contain three relay outputs: defrost heater (20A), evaporator fan (10A), and alarm (5A). The board will include connection points for alarm systems provided by others.

Medium temperature systems come with one preprogrammed defrost per day if it needs to run in safe mode and to ensure oil return to the compressor if no demand defrosts are required. All other defrosts are by demand which will be activated by the 3 factory mounted sensors on the evaporator coil.

COOLER CONDENSER:

Compressors shall be scroll type and shall operate on R-454A refrigerant. Multiple compressors shall be used to satisfy load requirements. Small loads shall be combined in a multiplex arrangement and satisfied using a single compressor. Each compressor unit shall also include dual pressure control, sight glass, liquid line drier and suction and discharge vibration eliminators. Provide one (1) RFON060M4ADA Medium temperature, 35-degree Fahrenheit, pre-assembled remote, scroll outdoor remote refrigeration condenser with voltage to be 208/1. Provide and install weather-proof stainless-steel housing, low ambient controls, and a mounting stand. Low pressure bypass and ambient safety accessories are to be provided on the outdoor condensing units to protect them under extreme outside temperatures of approximately -20 F.

COOLER EVAPORATOR:

Evaporator Coils - Matching evaporators shall be provided as required to complete the system. Evaporators shall be provided with mounted expansion valve and room thermostat. Evaporators shall be provided with the Eco-Smart Controller System. Evaporators shall be off cycle; electric or reverse cycle defrost. Provide one (1) RAL6A081ADA evaporator unit and voltage of 120/1. Low profile evaporator coil with expansion valve, thermostat, and solenoid factory mounted. Evaporators shall be forced air type designed for ceiling installation. Air discharge shall be parallel to the walk-in ceiling. Fan motors, guards, multi-fin, and tube-type coil shall be housed in heavy gauge aluminum housing. Unit shall have drain pan with suitable drain-pipe connection. Defrost shall be initiated only when required by demand defrost settings and temperature terminated with built-in fail-safe control. All cooler systems are equipped with an "off cycle" timer to maximize heat transfer and maintain optimum energy efficiency. Evaporators shall be U.L. listed.

Piping Specifications:

- All refrigeration piping will be performed by the Food Service Equipment Contractor. This Contractor will install all components and piping per the manufacturer's recommendations. The Food Service Equipment Contractor will perform all refrigeration piping. This Contractor will install all components and piping per the manufacturer's recommendations. Traps, piping hangers and supports, and all associated hardware shall be provided by this contractor.
- Line sizes must be appropriately sized for the length of run. If units have reverse-cycle defrost, liquid line shall be upsized to one nominal size.
- FSEC will make all final connections to the evaporator and the condenser, charge and test the operation of the system.
- Copper drain lines, heated and insulated where needed, installed by the Food Service Equipment Contractor.

Electrical Specifications:

- Electrical Contractor is to provide final electrical connection to the condenser, evaporator, air curtain, and lights. Coordinate location with the General Contractor.
- Provide Cat5 or Cat 6 cable from the evaporator to the building internet network or Food Service director's office for monitoring of the refrigeration system, to be installed by the E.C.

Wiring:

- All interior wiring shall be "liquidtight" fittings and sealed to prevent water migration.
- The use of Romex, BX, and MC Cable is prohibited and should be deemed to not meet specifications.
- All control wiring and inter-wiring is to be done by the Food Service Equipment Contractor.
 - Control wiring from evaporator to safety valve is by the F.S.E.C.

Warranty:

The successful bidder shall provide written warranties that specify, subject to normal and accepted use, at a minimum:

- Five Year Compressor Warranty
- Three Year Service / Workmanship Warranty on refrigeration installation.
- One Year Manufacturer's Warranty on all other components.

ITEM: 134

QUANTITY: 4

MANUFACTURER: CAMBRO

MODEL: CPU-480 SERIES

DESCRIPTION: WALK-IN COOLER SHELVING

- (2) Cambro Model #CPU184872VS4480, Camshelving Premium Starter Unit, 18"deep x 48" long x 72" tall, 4-tier, withstands temperature -36°F to 190°F, includes: (3) vented and (1) solid polypropylene shelf plates with Camguard antimicrobial protection, (2) pre-assembled post kits, (8) traverses with molded-in dovetails, 800-pound capacity per shelf with a 2,000-pound maximum capacity, speckled gray, and NSF listed.
- (2) Cambro Model #CPA184872VS4480, Camshelving Premium Add-On Unit, 18"deep x 48" long x 72" tall, 4-tier, withstands temperature -36°F to 190°F, includes: (3) vented and (1) solid polypropylene shelf plates with Camguard antimicrobial protection, (1) pre-assembled post kits, (8) traverses with molded-in dovetails, 800-pound capacity per shelf with a 2,000-pound maximum capacity, speckled gray, and NSF listed.
- (4) Model #CSDS18H10480 Camshelving Premium Dunnage Support, 18" deep x 10" tall, speckled gray, and NSF listed.
- Verify sizes with site conditions and shelf spacing with owner.

ITEM: 135 & 136

QUANTITY: 1

MANUFACTURER: ARTIC INDUSTRIES

MODEL: RFON230L4ADA / RAL6E058DDA

DESCRIPTION: WALK-IN FREEZER REFRIGERATION

Walk-In Freezer will be provided with a condensing unit and evaporator for refrigerated equipment in accordance with ASHRAE standards. All systems shall be supplied with complete controls for a working system. Each system shall consist of a new compressor unit mounted on a structural stain-less-steel base with cover and winter controls.

Compressors units shall be accessible preassembled remote, hermetic/scroll type, air cooled units for outdoor installation with matching evaporator. The condenser shall be equipped with EC fan motors and evaporator fans shall utilize the ECM type two-speed fan motors. All refrigeration equipment shall comply with the Federal Regulations for energy efficiency.

Low temperature unit should utilize R-454a refrigerant. The manufacturer calculates heat loads and provides systems with a minimum of 105% of needed capacity to maintain holding temperature -10° F in freezers. Calculations shall take into consideration box ambient, refrigeration system ambient, airflow, and exposure to sunlight and altitude. Interconnection of refrigeration lines, insulation, and electrical wiring shall be accomplished by the appropriate trades and shall be a portion of the Kitchen Equipment Contract.

The refrigeration system in the walk-in will be equipped with an on-demand defrost controller factory mounted to the evaporator coil(s). The controller will be custom designed for refrigeration systems to control the electric expansion valve in response to true evaporator superheat and return air temperature. Power wiring for the evaporator coils will be provided by the E.C. as required. Off cycle and electric defrost is also available.

Additionally, a refrigeration system containing an on-demand controller will consist of the following factory-mounted parts:

- Electronic controller board with three- digit LED and push button panel interface for setup
- Three solid state temperature sensors
- Pressure transducer
- External relay to control liquid line solenoid valve or compressor contactor
- Electric expansion valve
- 24V transformer

The Smart Controller board will contain three relay outputs: defrost heater (20A), evaporator fan (10A), and alarm (5A). The board will include connection points for alarm systems provided by others.

Low temperature systems come with two preprogrammed defrost per day if it needs to run in safe mode and to ensure oil return to the compressor if no demand defrosts are required. All other de-frosts are by demand which will be activated by the 3 factory mounted sensors on the evaporator coil.

The Smart Controller system will: Float the head pressure, reduce system refrigerant charge by a minimum of one third, and reduce the time when hot gas is used to defrost the coil. Any proposed alternatives must perform the energy-saving functions of all three features.

FREEZER CONDENSER:

Compressors shall be hermetic/scroll type and shall operate on R-454A refrigerant. Multiple compressors shall be used to satisfy load requirements. Small loads shall be combined in a multiplex arrangement and satisfied using a single compressor. Each compressor unit shall also include dual pressure control, sight glass, liquid line drier and suction and discharge vibration eliminators. One (1) RFON230L4ADA Low temperature, -10 -degree Fahrenheit, pre-assembled remote, hermetic/scroll type outdoor remote refrigeration condenser, and voltage to be 208/1. Low temperature units also are to include evaporator drain line heaters (by others). Low pressure bypass and ambient safety accessories are to be provided on the outdoor condensing units to protect them under extreme outside temperatures of approximately -20 F.

FREEZER EVAPORATOR:

Matching evaporators shall be provided as required to complete the system. Evaporators shall be provided with mounted expansion valve and room thermostat. Evaporators shall be provided with the On-Demand Defrost Control System. Evaporators shall be off cycle; electric or reverse cycle defrost. Provide one (1) RAL6E058DDA evaporator unit with voltage of 120/1. Low profile evaporator coil with expansion valve, thermostat, and solenoid factory mounted. Evaporators shall be forced air type designed for ceiling installation. Air discharge shall be parallel to the walk-in ceiling. Fan motors, guards, multi-fin, and tube-type

coil shall be housed in heavy gauge aluminum housing. Unit shall have drain pan with suitable drainpipe connection. Freezer evaporators shall utilize electric defrost and heated drain pan. Defrost shall be initiated only when required by demand defrost settings and temperature terminated with built-in fail-safe control. Evaporators shall be U.L. listed.

Piping Specifications:

- All refrigeration piping will be performed by the Food Service Equipment Contractor. This Contractor will install all components and piping per the manufacturer's recommendations.
- Line sizes must be appropriately sized for the length of run. If units have reverse-cycle defrost, liquid line shall be upsized to one nominal size.
- FSEC will make all final connections to the evaporator and the condenser, charge and test the operation of the system.
- Copper drain lines, heated and insulated where needed, installed by the Food Service Equipment Contractor.
- The heat tape is to be powered from a separate circuit provided by the E.C. and connected by the F.S.E.C.

Electrical Specifications:

- Electrical Contractor is to provide final electrical connection to the condenser, evaporator, air curtain, and lights. Coordinate location with the General Contractor.
- Provide Cat5 or Cat 6 cable from the evaporator to the building internet network or Food Service director's office for monitoring of the refrigeration system, to be installed by the E.C.

Wiring:

- All interior wiring shall be "liquidtight" fittings and sealed to prevent water migration.
- The use of Romex, BX, and MC Cable is prohibited and should be deemed to not meet specifications.
- All control wiring and inter-wiring is to be done by the Food Service Equipment Contractor.
 - Control wiring from evaporator to safety valve is by the F.S.E.C.

Warranty:

The successful bidder shall provide written warranties that specify, subject to normal and accepted use, at a minimum:

- Five Year Compressor Warranty
- Three Year Service / Workmanship Warranty on refrigeration installation.
- One Year Manufacturer's Warranty on all other components.

ITEM: 137

QUANTITY: 2

MANUFACTURER: CAMBRO

MODEL: CPU-480 SERIES

DESCRIPTION: WALK-IN FREEZER SHELVING

- (2) Cambro Model #CPU186072VS4480, Camshelving Premium Starter Unit, 18"deep x 60" long x 72" tall, 4-tier, withstands temperature -36°F to 190°F, includes: (3) vented and (1) solid polypropylene shelf plates with Camguard antimicrobial protection, (2) pre-assembled post kits, (8) traverses with molded-in dovetails, 600-pound capacity per shelf with a 2,000-pound maximum capacity, speckled gray, and NSF listed.
- (2) Model #CSDS18H10480 Camshelving Premium Dunnage Support, 18" deep x 10" tall, speckled gray, and NSF listed.
- Verify sizes with site conditions and shelf spacing with owner.

ITEM: 138

QUANTITY: 1

MANUFACTURER: CAMBRO

MODEL: DRS SERIES

DESCRIPTION: WALK-IN FREEZER DUNNAGE RACK

- (1) Model #DRS360480 S-Series Dunnage Rack, 21" deep x 36" wide x 12" tall, slotted top, 3000-pound load capacity, polypropylene, one-piece, seamless double wall construction, includes (1) Cam-link®, 4" square legs, speckled gray, NSF.
- Verify sizes with site conditions.

ITEM: 139

QUANTITY: 2

MANUFACTURER: METRO

MODEL: MX-G SERIES

DESCRIPTION: POT & PAN RACK

Each unit consists of four (4) posts, four (4) shelves, and four (4) locking casters.

- (4) Model #MX2448G Metro-Max I Shelf, 48" wide x 24" deep, removable open grid polymer mats with Microban antimicrobial protection, reinforced type 304 stainless steel corners, wedge connectors with quick adjust corner releases, NSF.
- (4) Model #MX2442G Metro-Max I Shelf, 42" wide x 24" deep, removable open grid polymer mats with Microban antimicrobial protection, reinforced type 304 stainless steel corners, wedge connectors with quick adjust corner releases, NSF.
- (8) Model #MX70UP Metro-Max I Post, 70" high, open pole for use with stem casters, polymer construction with built in Microban antimicrobial product protection, NSF.
- (8) Model #5PCBX Stem Caster, brake, 5" diameter, polyurethane wheel tread with donut bumpers.
- (2) Model #XTR2448XE Cutting Board and Tray Drying Rack System thirty-four (34) tray capacity, 6" up-rights with 1 1/8" spacing, mounts on 48" wide x 24" deep frame, taupe epoxy, NSF.
- (1) Model #XTR2448XEa Cutting Board and Tray Drying Rack System fourteen (14) tray capacity, 6" up-rights with 3" spacing, mounts on 48" wide x 24" deep frame, taupe epoxy, NSF.
- (1) Model #XDRIP Adjustable drip tray. Provide removable drip pan as part of this item.
- (1) Vollrath Model #8002410, Super Pan 1/1 Food Pan, 2 1/2" deep, low-temp polycarbonate clear plastic, top flange corners with concave indentation, anti-jamming, ramped sides, reverse form flattened edge, framing shoulder, interchanges with SPV stainless steel pan line, NSF, made in USA.
- The bottom three shelves hold the drying rack. (1) with the 3" spacing and (2) with the 1 1/8" spacing.
- The 42" has 4 shelves. The 48" unit includes the drying racks.
- Verify shelf spacing with owner.

ITEM: 140

DESCRIPTION: SPARE NUMBER

ITEM: 141

QUANTITY: 5

MANUFACTURER: CAMBRO

MODEL: PREMIER SERIES

DESCRIPTION: DRY STORAGE SHELVING

- (4) Cambro Model #CPMU244875V4480 Camshelving Premium Mobile Starter Unit, 24" deep x 48" long x 75" tall, 4-tier, withstands temperature -36°F to 190°F includes: (4) vented polypropylene shelf plates with Camguard antimicrobial protection, (2) pre-assembled post kits, (8) traverses, molded-in dovetails, (2) sets of post connectors, (4) premium swivel casters with total locking brake, 900 pound max capacity, speckled gray, and NSF listed
- (1) Cambro Model #CPMU244275V4480 Camshelving Premium Mobile Starter Unit, 24" deep x 42" long x 75" tall, 4-tier, withstands temperature -36°F to 190°F includes: (4) vented polypropylene shelf plates with Camguard antimicrobial protection, (2) pre-assembled post kits, (8) traverses, molded-in dovetails, (2) sets of post connectors, (4) premium swivel casters with total locking brake, 900 pound max capacity, speckled gray, and NSF listed
- Verify sizes with site conditions and shelf spacing with owner.

ITEM: 142

QUANTITY: 1

MANUFACTURER: HOSHIZAKI

MODEL: KM-161BAJ

DESCRIPTION: ICE-MAKER WITH BIN

Ice Maker With Bin, crescent cube-Style, 23 3/4" wide, air-cooled, self-contained condenser, production capacity up to 163 pounds per 24 hours at 70°/50°, 78-pound built-in ice storage capacity, front opening bin, stainless steel exterior, front-in, front-out airflow with removable air filter, power switch accessible without removing front panel, 6" painted legs, UL and NSF listed.

- 120/60/1
- Three-Year parts and labor warranty on entire machine
- Five-Year parts and labor warranty on evaporator
- Five-Year parts warranty on compressor and air-cooled condenser
- Single Water Filtration System
- (1) Replacement Water Filter Cartridge
- One-Year warranty on entire water filtration system

ITEM: 143

QUANTITY: 1

MANUFACTURER: ADVANCE TABCO

MODEL: 7-PS-91

DESCRIPTION: HAND SINK

Hand Sink, wall model with pedestal base, approximately 14" x 10" x 5" sink bowl with inverted "V" edge, 8" integral backsplash, 20-gauge, #304 stainless steel all welded construction, one (1) hole for splash-mounted faucet, 6" apron, includes hands free electronic faucet, basket drain, mounting bracket and clip with hardware, and NSF listed.

- Model #7-PS-10 P-Trap Assembly
- Electronic Faucet, splash type, gooseneck, with metering/check valve.
- Full length sink apron.
- Front Access Panel

- Mount and seal to the wall
- Coordinate with P.C. to make sure utilities and censored faucet components fit within the stainless-steel enclosure provided with the sink.

ITEM: 144

QUANTITY: 1

MANUFACTURER: TITAN STAINLESS

MODEL: FS-CDT3084-US-OS

DESCRIPTION: CLEAN DISHTABLE

Clean dish table to be custom built as per General Specifications, table shall be approximately 7'0" x 2'6" x 34" high to work surface, 14-gauge stainless steel top with raised rolled edges, corners bull nosed, provide a 10" backsplash with capped ends at the dishwasher, stainless steel legs, full length stainless steel under shelf with a 2" upturn at rear and ends. Provide the table with stainless steel gussets, legs, flanged feet on front legs only, and bullet feet on the balance.

- Provide a slanted dish rack wall shelf shall be custom built as per General Specifications, approximately 5'2", 16-gauge 304 stainless steel with drip trough and drip tube on left front corner, and 2" up-turn at rear to be tight to the wall, to hold (3) dish racks.
 - Verify mounting height with owner.
 - Coordinate wall backing with General Contractor
- Secure flanged feet to the floor with stainless steel fasteners
- Seal unit to the wall and to the dishwasher
- Secure table to the dishwasher with stainless steel fasteners

ITEM: 145

QUANTITY: 1

MANUFACTURER: HOBART

MODEL: AM16VLT-ADV-2

DESCRIPTION: DISHWASHER

Ventless Dishwashing Machine, tall chamber (27"), door type, energy recovery, automatic soil remover, drain water energy recovery, high temp sanitizing, internal condensing system, (38) racks per hour, straight-thru installation, user-friendly smart touchscreen controls, WIFI connectivity with Smart Connect app, complete delime with delime notification, auto-dispensing, booster-guard with Sense-A-Temp booster, electric tank heat, "X" shaped wash arms, scrap screen and basket, door actuated start, door lock, stainless steel tank, tank shelf, chamber, trim panels, frame and feet, pumped drain air-gap, drain water tempering, UL and NSF listed.

- 208/3
- Energy Star listed
- Water Hammer Arrestor – Assembly includes 3/4" brass pressure regulator, pressure gauge, shock arrestor, and garden hose adapter
- Factory Startup
- Touch Screen Guard
- One-year parts and labor warranty
- (6) Vollrath Model #TR3 Traex Full Size Peg Rack, 3-1/4" max inside height, (9) rows x (9) rows with 1-7/8" peg spacing, open bottom and sidewall, handles on all (4) sides, co-polymer plastic, full size (19-3/4" x 19-3/4") double wall construction, snap-fit extenders, Royal Blue #44, NSF, Made in USA.

- (6) Vollrath Model #TR2 Traex Full Size Flatware Rack, full size, 19-3/4"wide x 19-3/4"deep x 4"high, (compartment 3-1/4"H), handles on all (4) sides, double wall construction, co-polymer plastic, Royal Blue - #44, NSF, Made in USA.

ITEM: 146

QUANTITY: 1

MANUFACTURER: TITAN STAINLESS

MODEL: FS-SDT30723094-US

DESCRIPTION: SOILED DISHTABLE

Soiled dish table custom built as per General Specifications. Dish table section shall be approximately 6'0" x 2'6" x 7'10" x 2'6" wide, 34" high to work surface, 14-gauge 304 stainless steel top with raised rolled edge and rounded corners, provide a 10" rear and side-splash with capped ends at the dishwasher. Provide partial length under shelf with 2" rear and side upturn under the pass window section with cross rails on the sides and rear of the balance, stainless steel gussets, legs, and flanged feet on front ends with bullet feet on rear and centers. Pre-rinse faucet is to be mounted in a recessed section on the backsplash. Provide pass window ledge integral to the table-top and a stainless-steel window frame with 2" return on the cafeteria and kitchen side.

- Provide a raised flat section in the backsplash to mount the pre-rinse faucet.
- Provide 20" x 20" x 6" pre-rinse sink with removable rack slide.
- Coordinate and provide allowance for the roll-down shutter door at the pass-window opening.
- Secure flanged feet to the floor with stainless steel fasteners
- Seal unit to the wall and to the dishwasher
- Secure table to the dishwasher with stainless steel fasteners
- (1) T&S Brass Model #B-0113-CR-BJ-ST, Easy-Install Pre-Rinse Faucet, deck mount, single hole base, 1.07 GPM swivel spray valve (B-0107-J), 44" flexible stainless-steel hose, 24" riser, 18" flexible supply lines, 6" wall bracket, quarter-turn Cerama cartridges, accessory tee, low lead.
- (1) T&S Brass Model #B-3970-01, Waste Valve, lever handle, 3 1/2" sink opening, 2" drain outlet with 1 1/2" adapter and overflow assembly.

END OF SECTION 114000



FOOD SERVICE ELECTRICAL SCHEDULE

NO.	QTY.	CATEGORY	VOLTS	PH	AMPS	HP	CONNECTION	AFF	REMARKS
100	1	MILK COOLER	120	1	2.7 A	1/5	NEMA 5-15P	36"	
101	1	HOT FOOD STATION	208	1	39.4 A		NEMA L14-20P	4"	120/208 REQUIRED, (4) CONNECTIONS 9.85A EACH; STUB UP FROM FLOOR WITH OUTLET BOX MOUNTED HORIZONTALLY
102	1	BREATH GUARD	120	1	0.3 A		NEMA 5-15P		CONNECT THROUGH #101
103	1	HOT/COLD FOOD STATION	120	1	21.7 A	1/3	NEMA 5-15P	4"	(2) CONNECTIONS REQUIRED 10.85A EACH; STUB UP FROM FLOOR WITH OUTLET BOX MOUNTED HORIZONTALLY
104	1	BREATH GUARD	120	1	0.3 A		NEMA 5-15P		CONNECT THROUGH #103
105	1	COLD FOOD STATION	120	1	9.7 A		NEMA 5-15P	4"	STUB UP FROM FLOOR WITH OUTLET BOX MOUNTED HORIZONTALLY
106	1	BREATH GUARD	120	1	0.3 A		NEMA 5-15P		CONNECT THROUGH #105
107	1	CASHIER STAND	120	1	15.0 A		NEMA 5-15P	4"	STUB UP FROM FLOOR WITH OUTLET BOX MOUNTED HORIZONTALLY; DATA CONNECTION REQUIRED
112	1	HEATED CABINET	208	1	7.2 A		NEMA 6-15P	36"	
113	1	EXHAUST HOOD	120	1	15.0 A		DIRECT	DFA	DATA CONNECTION REQUIRED; SEE EXHAUST HOOD DRAWINGS FOR DETAILS
114	1	FIRE SUPPRESSION SYSTEM	120	1	15.0 A		DIRECT	DFA	SEE EXHAUST HOOD DRAWINGS FOR DETAILS
115	1	DOUBLE COMBI OVEN	208	3	164.4 A		DIRECT	36"	208/240 REQUIRED, (2) CONNECTIONS PER UNIT 62.2A EACH; DATA CONNECTION REQUIRED
116	1	GRIDDLE	208	3	34.0 A		DIRECT	36"	
117	1	REFRIGERATED EQUIPMENT STAND	120	1	2.4 A	1/4	DIRECT	36"	
118	1	RANGE	208	3	49.0 A		DIRECT	36"	
121	1	WORK TABLE	120	1	15.0 A		DIRECT	4"	STUB UP FROM FLOOR
123	1	REACH-IN REFRIGERATOR	120	1	5.4 A	1/2	NEMA-5-15P	DFA	
124	1	HAND SINK	120	1	1.0 A		NEMA 5-15P	18"	
128	1	MICROWAVE	120	1	15.0 A		NEMA 5-15P	36"	
131	1	WALK-IN COOLER/FREEZER	120	1	15.0 A		DIRECT	DFA	DATA CONNECTION REQUIRED; SEE WALK-IN DRAWINGS FOR DETAILS
131.1	1	AIR CURTAIN	208	1	1.7 A	1/5	DIRECT	DFA	
132	1	WALK-IN COOLER EVAPORATOR	120	1	1.0 A		DIRECT	DFA	SEE WALK-IN DRAWINGS FOR DETAILS
133	1	WALK-IN COOLER CONDENSER	208	1	6.0 A	1/2	DIRECT	36"	SEE WALK-IN DRAWINGS FOR DETAILS
135	1	WALK-IN FREEZER EVAPORATOR	120	1	5.4 A		DIRECT	DFA	SEE WALK-IN DRAWINGS FOR DETAILS
135.1	1	WALK-IN FREEZER DRAIN LINE HEATER	120	1	10.0 A		DIRECT	DFA	
136	1	WALK-IN FREEZER CONDENSER	208	1	14.8 A	2 1/3	DIRECT		SEE WALK-IN DRAWINGS FOR DETAILS
142	1	ICE MACHINE	120	1	7.1 A		NEMA 5-15P	36"	
143	1	HAND SINK	120	1	1.0 A		NEMA 5-15P	18"	
145	1	DISHWASHER	208	3	53.5 A		DIRECT	12"	208-240V REQUIRED; DATA CONNECTION REQUIRED

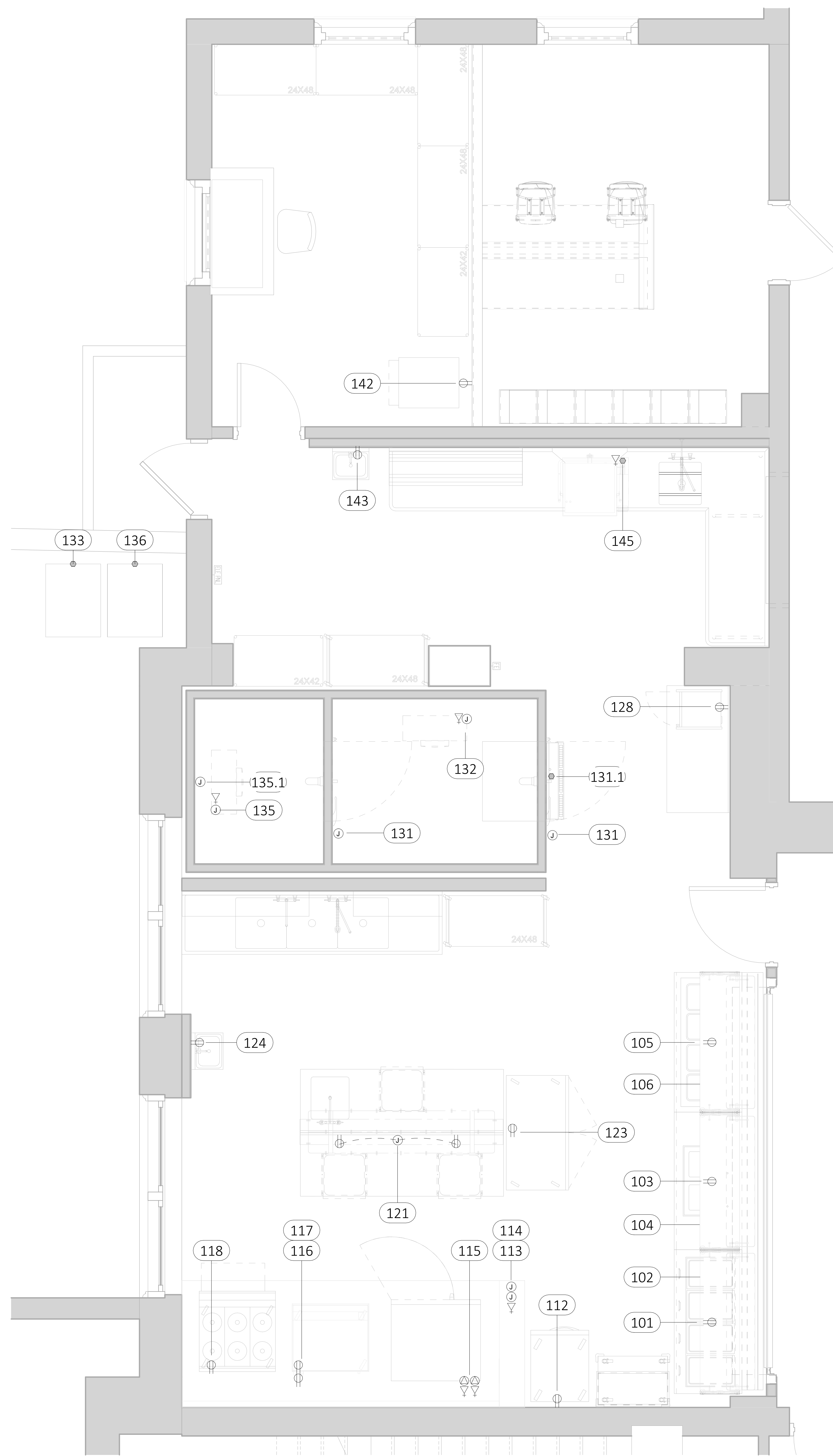

ELECTRICAL LEGEND

ABBR.	DESCRIPTION	SYMBOL
DIRECT	ELECTRICAL CONNECTION	⊕
DR	DUPLEX RECEPTACLE	⊕
SR1	SINGLE RECEPTACLE (120V)	⊕
SR2	SINGLE RECEPTACLE (208V)	⊕
	FIRE SUPPRESSION PULL BOX	⊕
JB	JUNCTION BOX	⊕
SW	SWITCH	⊕
E	UDS ELECTRICAL	⊕
FS	UDS FIRE FUEL SHUT-OFF	⊕
F	HOOD FAN CONTROL	⊕
L	HOOD LIGHT CONTROL	⊕
POS	CATS DATA CABLE	▽
V	VOLTAGE	
PH	PHASE	
KW	KILOWATTS	
HP	HORSEPOWER	
A	AMPERE	
AFF	ABOVE FINISHED FLOOR	
DFA	DOWN FROM ABOVE	

- GENERAL ELECTRICAL NOTES**
- *THE FOLLOWING NOTES ARE TYPICAL. SEE SPECIFICATIONS FOR PROJECT SPECIFIC DETAILS*
- ALL CONNECTIONS SHOW RELATIVE TO FOOD SERVICE EQUIPMENT ONLY.
 - E.C. SHALL PROVIDE ALL ROUGH-IN AND FINAL CONNECTIONS TO ALL FOOD SERVICE EQUIPMENT.
 - E.C. TO BRANCH CONNECTIONS AS REQUIRED.
 - F.S.E.C. TO SUPPLY ALL FIXTURES AND COMPONENTS SPECIFIED IN EQUIPMENT SPECIFICATIONS. ELECTRICAL CONTRACTOR SHALL INSTALL AND CONNECT ALL ELECTRICAL COMPONENTS TO MAKE FINAL CONNECTIONS UNLESS OTHERWISE NOTED.
 - SWITCHES, STARTERS, LOCK-OUT DEVICES, DISCONNECTS, AND ANY OTHER REQUIRED ELECTRICAL COMPONENTS, WILL BE MOUNTED AND INSTALLED BY THE ELECTRICAL CONTRACTOR AND SHALL MEET ALL O.S.H.A. AND CODE REQUIREMENTS.
 - DO NOT RUN ANY EXPOSED LINES WHERE POSSIBLE.
 - ALL MAIN BREAKER PANELS, DISCONNECT SWITCHES, RECEPTACLES, AND RECEPTACLE COVER PLATES ARE TO BE PROVIDED AND INSTALLED BY THE ELECTRICAL CONTRACTOR.
 - ELECTRICAL CONTRACTOR IS TO PROVIDE AND PERFORM WIRING BETWEEN THE FIRE SUPPRESSION SYSTEM, MICRO-SWITCHES, COOKING EQUIPMENT, AND BUILDING'S FIRE ALARM SYSTEM. SHUNT TRIP CIRCUITRY WILL BE REQUIRED TO SHUT DOWN COOK LINE IF AN EMERGENCY.
 - F.S.E.C. IS TO PROVIDE AND INSTALL ALL DRAIN LINE HEATER CABLE ON WALK-IN FREEZER DRAIN LINES.
 - F.S.E.C. IS RESPONSIBLE TO INSTALL AND MAKE ELECTRICAL CONNECTIONS FOR ANY ADDITIONAL LIGHTING, TIME CLOCKS, OR OTHER ELECTRICAL ACCESSORIES SPECIFIED FOR THE WALK-IN UNITS.
 - F.S.E.C. TO PROVIDE ELECTRICAL SERVICE FOR THE WALK-IN DOOR HEATERS, LIGHTS, EVAPORATORS AND CONDENSERS, AND PROVIDE ELECTRICAL DISCONNECTS AT CONDENSERS.
 - THE F.S.E.C. SHALL PROVIDE PRE-ASSEMBLED REMOTE REFRIGERATION COMPONENTS AS REQUIRED BY THE EQUIPMENT SPECIFICATIONS. F.S.E.C. TO INSTALL, CONNECT, CHARGE REFRIGERATION LINES AND SYSTEMS, AND RUN AND TEST FOR PROPER OPERATION.
 - VERIFY FINAL EQUIPMENT REQUIREMENTS PRIOR TO INSTALLATION. REVISIONS TO EQUIPMENT MAY AFFECT THE ELECTRICAL CONTRACTOR'S SCOPE OF WORK OR MATERIAL REQUIREMENTS.
- *REFER TO ARCHITECT'S ELECTRICAL DRAWINGS FOR ADDITIONAL BUILDING ELECTRICAL REQUIREMENTS.

- VERIFICATION NOTE**
- ALL UTILITY INFORMATION SHOWN ON THESE DRAWINGS ARE DEEMED TO BE ACCURATE AT THE TIME OF CREATION.
 - EQUIPMENT MANUFACTURER'S RESERVE THE RIGHT TO CHANGE OR UPDATE THE EQUIPMENT REQUIREMENTS. THE CONSULTANT AND/OR ARCHITECT ARE NOT RESPONSIBLE FOR ANY OF THESE CHANGES.
 - THE FOOD SERVICE EQUIPMENT CONTRACTOR IS RESPONSIBLE TO VERIFY ALL DIMENSIONS AND UTILITY INFORMATION PRIOR TO ORDERING AND INSTALLATION. THIS CONTRACTOR IS TO PROVIDE ALL TRADES WITH THE MOST CURRENT INFORMATION AT ALL TIMES.

SEAL

ISSUED FOR BID 03/27/26

ISSUE DATE

KEY PLAN

PROJECT NO. 66-04-01-03-0-002-017

MEMASI PROJECT NO. 101-2403

FOOD SERVICE ELECTRICAL PLAN



1000 7th North Street, Suite B20
Liverpool, NY 13088
www.teamfstds.com | 315-498-8446

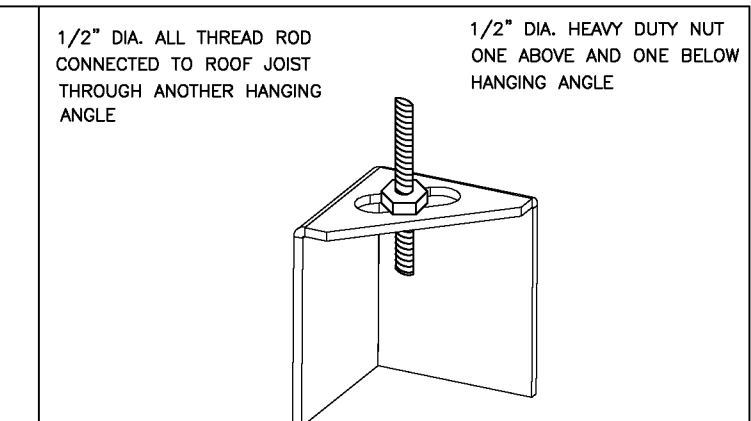

1/2" DIA. ALL THREAD ROD CONNECTED TO ROOF JUST THROUGH ANOTHER HANGING ANGLE

*ROD AND NUTS TO BE SUPPLIED BY INSTALLING CONTRACTOR. HANGING ANGLE IS PRE-PUNCHED AT FACTORY.

HOOD STYLE	DIM FROM DIM REAR	DIM FROM DIM FRONT (24" H)	DIM FROM DIM FRONT (30" H)
CANOPY ND2	4.166"	2.246"	2.246"
ND2-PSP-F	4.166"	2.246"	2.246"
BACKSHELF 2B47BD	2.00"	14.25"	-
VHB/VHB-G	36"X36"	42"X42"	48"X48"
FRONT/BACK DIMS BY SIZE	2.246"	2.246"	2.246"

HANGING ANGLE LOCATIONS

EXHAUST CFM=LENGTH OF HOOD X CFM/INCH (LOAD)
SUPPLY CFM=EXHAUST CFM X PERCENTAGE REQUIRED
TOTAL DUCT AREA=144 X (CFM)²
DUCT LENGTH= DUCT DEPTH

*CAPTIVE-AIRE VENTILATION DUCT SIZES ARE CALCULATED USING AN EXHAUST VELOCITY OF 1000-FPM AND A SUPPLY VELOCITY OF 1000-FPM.

CALCULATIONS UTILIZED

CAPTIVE-AIRE HOODS ARE BUILT IN COMPLIANCE WITH:

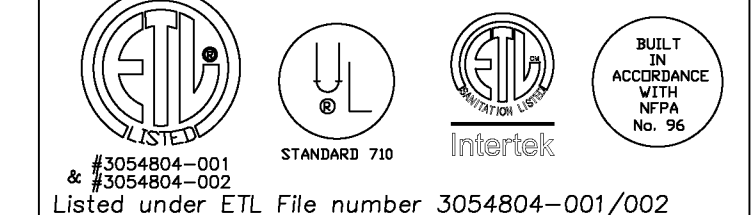

Listed under ETL File number 3054804-001/002

BUILDING CODES

MATERIAL	CLEARANCE REDUCTION SYSTEM
NON-COMBUSTIBLE	NONE REQUIRED
LIMITED-COMBUSTIBLE	3" UNSULATED STANDOFF
COMBUSTIBLE	1" INSULATED STANDOFF

CLEARANCE TO COMBUSTIBLES

INSTALLATION

1. ALL ELECTRICAL "FIELD" CONNECTIONS AND RELATED INTERCONNECTIONS BY ELECTRICAL CONTRACTORS.
2. ALL PLUMBING "FIELD" CONNECTIONS AND RELATED INTERCONNECTIONS BY PLUMBING CONTRACTORS.
3. HANGING BRACKETS LOCATED AND WELDED AS SHOWN ON PLANS. ALL OTHER HANGER MATERIALS PROVIDED BY INSTALLING CONTRACTORS.
4. ALL CONNECTIONS FROM CAPTIVE-AIRE DUCT PER MECHANICAL CONTRACTOR'S PLANS.
5. COOKING EQUIPMENT TO SHUTOFF IN EVENT OF FIRE.
6. EXHAUST FANS TO TURN ON IN EVENT OF FIRE.
7. ALL LIGHTS (FIXTURE SHOWN INSTALLED BY CAPTIVE-AIRE ARE FACTORY PREWIRED. INTERCONNECTIONS BETWEEN HOODS AND TO SWITCHES BY ELECTRICAL CONTRACTORS.
8. LAMPS FOR LIGHT FIXTURES BY INSTALLING CONTRACTORS.
9. SEISMIC RESISTANT ARE RESPONSIBILITY OF INSTALLING CONTRACTOR.
10. INSTALLING CONTRACTORS ASSUME ALL RELATED RESPONSIBILITY FOR VERIFICATION OF DIMENSIONAL DATA CONTAINED ON THESE DOCUMENTS FOR ACCURACY, INTEGRATION, AND ADMINISTRATION OF CODE REQUIREMENTS IN EFFECT PRIOR TO AND RELEASE FOR PRODUCTION OF EQUIPMENT SHOWN.

BALANCE

11. KITCHEN HOODS MUST BE BALANCED WITH KITCHEN.
12. KITCHEN SHALL BE NEGATIVE WITH RESPECT TO DINING AREA.
13. RESTAURANT SHALL BE POSITIVE WITH RESPECT TO AMBIENT PRESSURE.

ADDITIONAL

14. WRITTEN HOOD DIMENSIONS HAVE PRECEDENCE OVER SCALE.
15. SIGNED AND "APPROVED" COPIES OF THIS DOCUMENT MUST BE PROVIDED BY THE FACTORY PRIOR TO COMMENCEMENT OF FABRICATION.

GENERAL NOTES

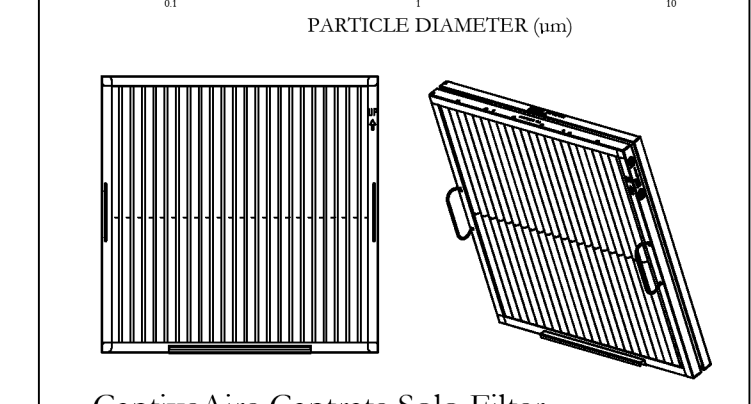
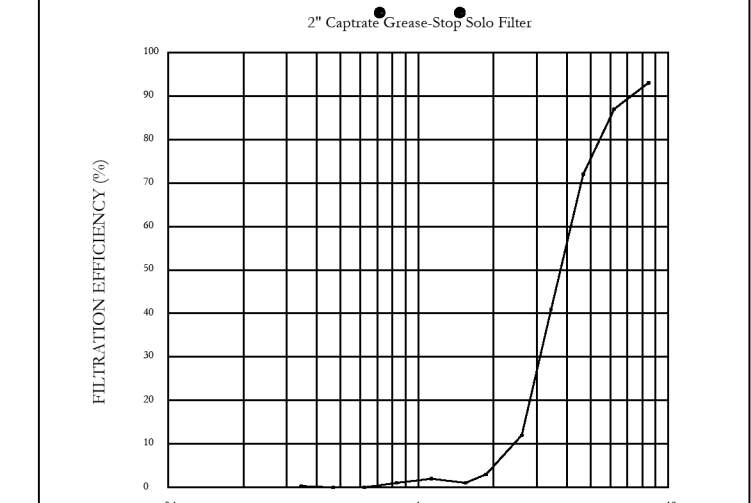

Captive Aire Captrate Solo Filter
ETL Listed Grease Extracting Filters
Made From 430 Stainless Steel

FILTER DETAIL

SPECIFICATION: CAPTRATE® GREASE-STOP® SOLID FILTER

THE CAPTRATE GREASE-STOP SOLID FILTER IS A SINGLE-STAGE FILTER FEATURING A UNIQUE S-Baffle DESIGN IN CONJUNCTION WITH A SLOTTED REAR Baffle DESIGN, TO DELIVER EXCEPTIONAL FILTRATION EFFICIENCY.

FILTER IS STAINLESS STEEL CONSTRUCTION, AND SIZED TO FIT INTO STANDARD 2-INCH DEEP HOOD CHANNELS.

UNITS SHALL INCLUDE STAINLESS STEEL HANDLES AND A FASTENING DEVICE TO SECURE THE TWO COMPONENTS WHEN ASSEMBLED.

GREASE EXTRACTION EFFICIENCY PERFORMANCE SHALL REMOVE AT LEAST 75% OF GREASE PARTICLES FIVE MICRONS IN SIZE, AND BOX GREASE PARTICLES SEVEN MICRONS IN SIZE AND LARGER, WITH A CORRESPONDING PRESSURE DROP NOT TO EXCEED 10 INCHES" DP" WATER GAUGE.

THE CAPTRATE GREASE-STOP SOLID WAS TESTED TO ASTM STANDARD ASTM F2510-05 MANUFACTURER APPROVED FOR USE IN SOLID FUEL APPLICATIONS AS A SPARK ARRESTER.

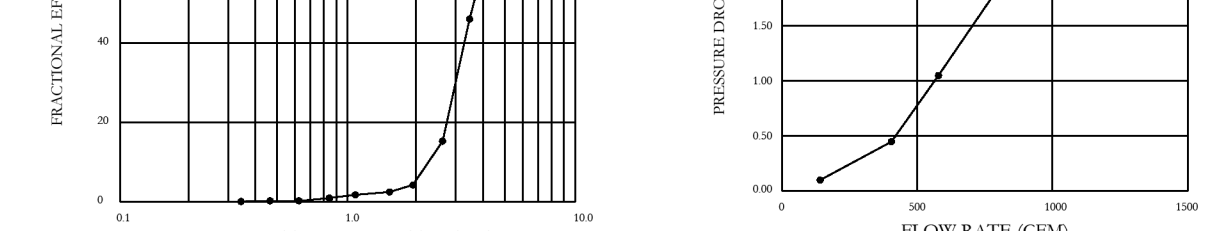

CAPTRATE FILTERS ARE BUILT IN COMPLIANCE WITH:
NFPA #96,
NSF STANDARD #6,
UL STANDARD #1046,
INT. MECH. CODE (CMC),
ULC-3649.



FOR QUESTIONS, CALL THE
Upstate New York
REGION 54
PHONE (585) 348 - 9118
EMAIL: rpg54@captrate.com

PATENT NUMBERS

EXHAUST HOODS ND-2/BD-2/SND-2 (CANADA) - CA PATENT 2520435 C.

HOOD INFORMATION - JOB#B285131									
HOOD NO	TAG	MODEL	MANUFACTURER	LENGTH	MAX COOKING TEMP	TYPE	APPLIANCE DUTY	DESIGN CFM/FT	TOTAL EXH. CFM
1	Item #113	6024 ND-2	CAPTIVEAIRE	12' 6"	450 DEG	I	MEDIUM	200	2500

HOOD INFORMATION																		
HOOD NO	TAG	TYPE	QTY	HEIGHT	LENGTH	EFFICIENCY @ 7 MICRONS	QTY	LIGHTS		UTILITY CABINETS		FIRE SYSTEM	HOOD HANGING WEIGHT					
								TYPE	WIRE GUARD	LOCATION	SIZE			TYPE	SIZE	MODEL #	SWITCHES QUANTITY	
1	Item #113	CAPTRATE SOLID FILTER	9	16"	16"	85% SEE FILTER SPEC	5	RECESSED ROUND	NO	LEFT	12"X60"X24"	TANK FS	4.0/4.0	SC-01110MA	1 LIGHT	1 FAN	YES	991 LBS

HOOD OPTIONS									
HOOD NO	TAG	OPTION							
1	Item #113	FIELD WRAPPER 1800" HIGH FRONT, LEFT, BACKSPLASH 8000" HIGH X 16200" LONG 430 SS VERTICAL STRUCTURAL FRONT PANEL.							

FIRE SYSTEM INFORMATION - JOB#B285131									
FIRE SYSTEM NO	TAG	TYPE	SIZE	MAX FP	DESIGN FP	SYSTEM	LOCATION ON HOOD		
1	ITEM #114	TANK FS	4.0/4.0	40	37	FIRE CABINET LEFT	LEFT, HOOD 1		

CLEARANCE TO COMBUSTIBLES

HOODS #	SURFACE	*CLEARANCE
1	TOP	18"
	FRONT	0"
	BACK	18"
	LEFT	0"
	RIGHT	18"

*0" CLEARANCE TO COMBUSTIBLES CONFORMS TO UL710 STANDARD.
+ HOOD MOUNTED UTILITY CABINETS REQUIRE 36" SERVICE CLEARANCE.

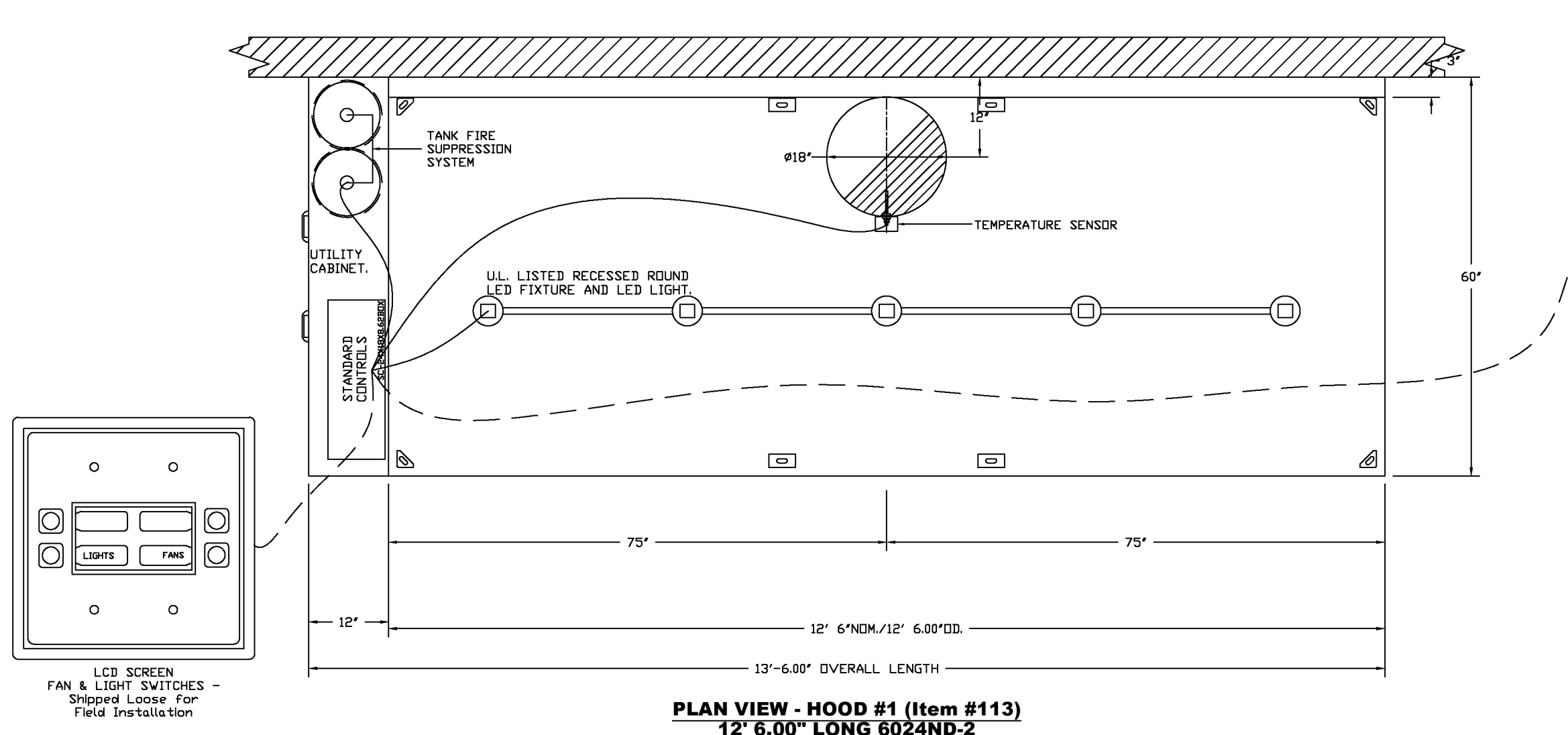

PLAN VIEW - HOOD #1 (Item #113)
12' 6.00" LONG 6024ND-2
NOTE: ADDITIONAL HANGING ANGLES PROVIDED FOR HOODS 12' AND LONGER.

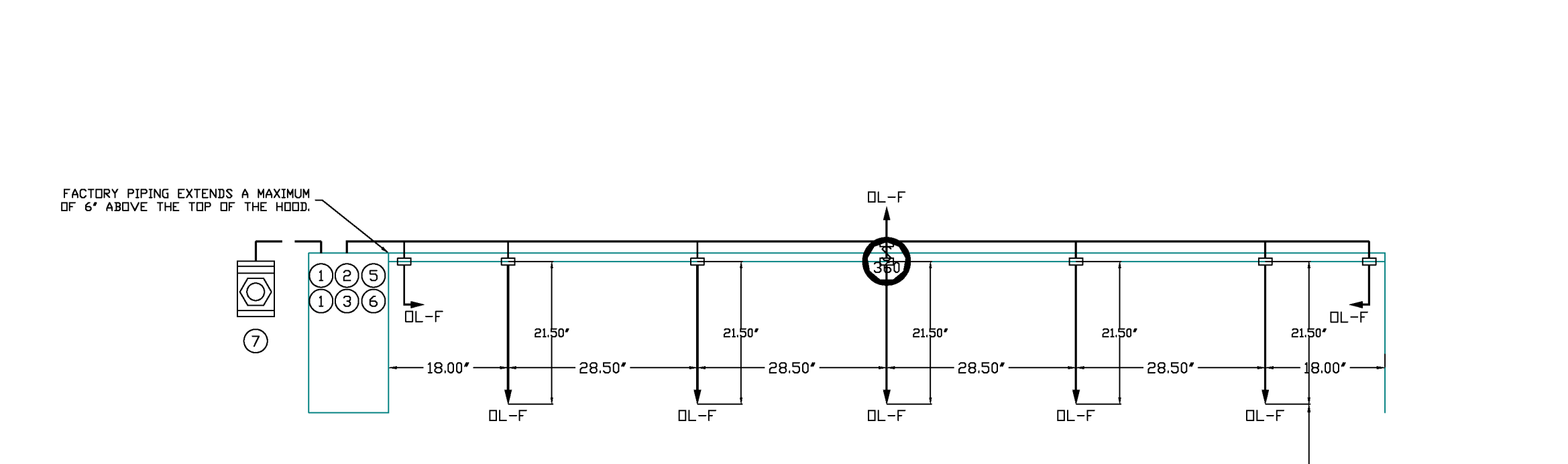

DETAIL - TANK FIRE SUPPRESSION SYSTEM

LEGEND - FIRE CABINET TANK SYSTEM

1. 4 GALLON TANK.
2. PRIMARY ACTUATOR RELEASE.
3. SECONDARY ACTUATOR RELEASE.
4. PRESSURE SUPERVISION SWITCH.
5. PRIMARY HOSE ASSEMBLY.
6. SECONDARY HOSE ASSEMBLY.
7. REMOTE MANUAL ACTUATION DEVICE.

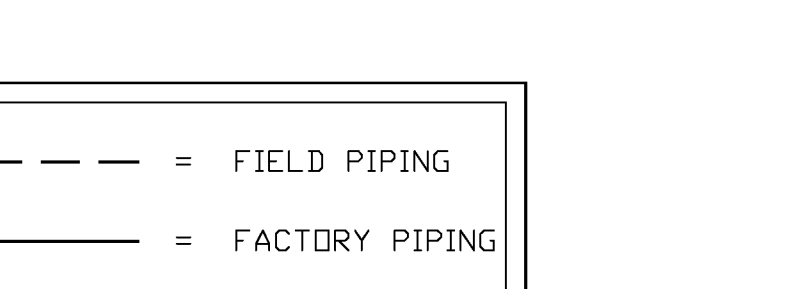

TANK MANUAL ACTIVATION DEVICE DETAIL

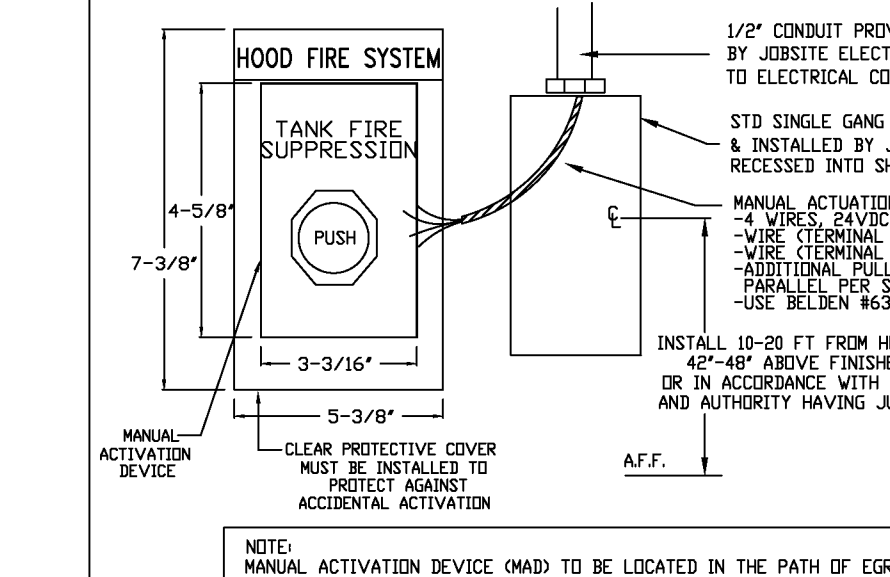

NOTE: MANUAL ACTIVATION DEVICE (MAD) TO BE LOCATED IN THE PATH OF EGRESS, FREE FROM OBSTRUCTION COORDINATE LOCATION WITH FIRE SYSTEM CONTRACTOR.

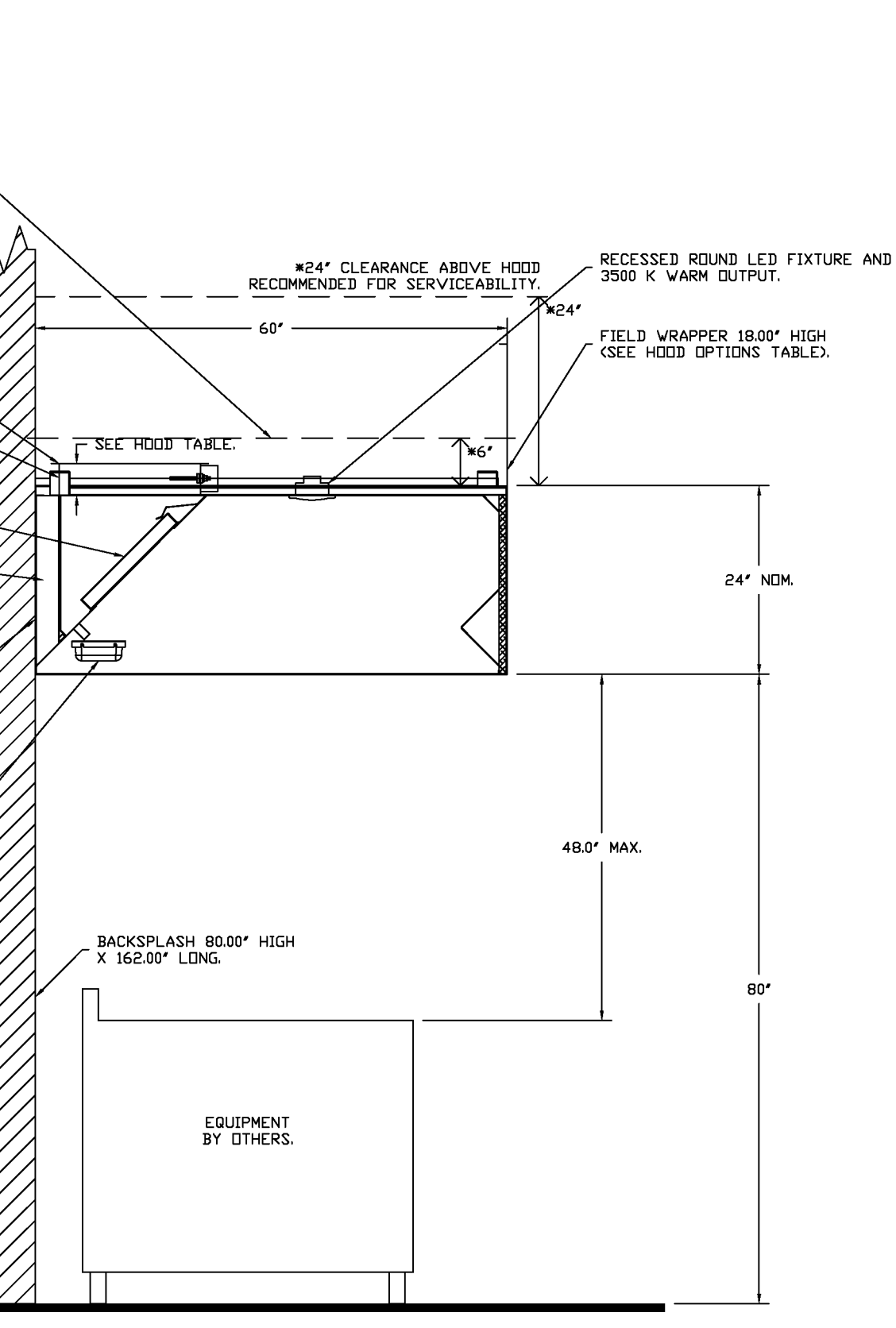

SECTION VIEW - MODEL 6024ND-2 HOOD - #1 (Item #113)

INCLUDES: FIELD INSTALLATION AND HOODUP DURING NORMAL BUSINESS HOURS BY CERTIFIED INSTALLERS ONLY IN THE LOCATION NOTED ABOVE. TWO SITE VISITS ONLY (ONE VISIT TO SET PULL STATION & SYSTEM HOODUP AND ONE VISIT FOR (ONE TEST) ADDITIONAL VISITS WILL RESULT IN ADDITIONAL CHARGES). ONE MECHANICAL OR ELECTRICAL GAS VALVE PER SYSTEM AT A MAXIMUM SIZE OF 2" PERM. AND SYSTEM TEST.
EXCLUDES: UNION LABOR & PREVAILING WAGE LABOR & WAGES WILL BE ADDED IF APPLICABLE, GAS VALVE INSTALLATION, ELECTRICAL HOODUP AND CONNECTIONS, HANGING OF FIRE CABINET, SLOTTED TOP, HANDHELD EXTINGUISHER(S), ON-SITE RE-PIPING DUE TO EQUIPMENT LAYOUT CHANGES.

ISSUED FOR BID 03/27/26
ISSUE DATE

KEY PLAN

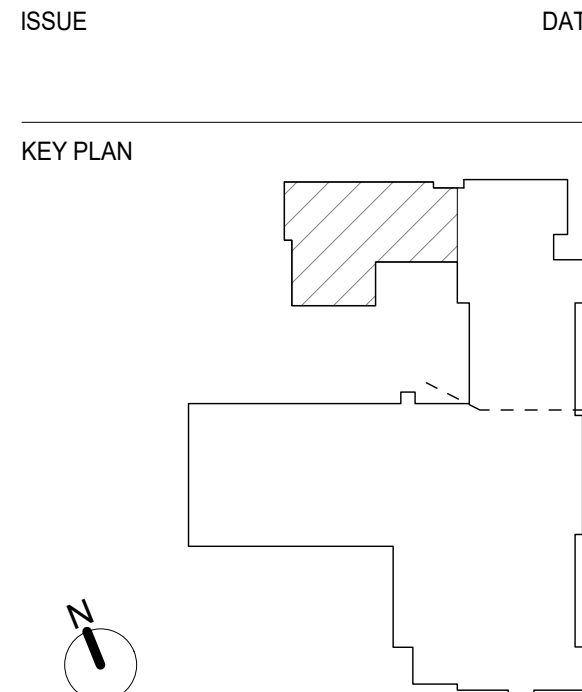

PROJECT NO. 66-04-01-03-0-002-017
MEMASI PROJECT NO. 101-2403

VERIFICATION NOTE

1. ALL UTILITY INFORMATION SHOWN ON THESE DRAWINGS ARE DEEMED TO BE ACCURATE AT THE TIME OF CREATION.
2. EQUIPMENT MANUFACTURER'S RESERVE THE RIGHT TO CHANGE OR UPDATE THE EQUIPMENT REQUIREMENTS. THE CONSULTANT AND/OR ARCHITECT ARE NOT RESPONSIBLE FOR ANY OF THESE CHANGES.
3. THE FOOD SERVICE EQUIPMENT CONTRACTOR IS RESPONSIBLE TO VERIFY ALL DIMENSIONS AND UTILITY INFORMATION PRIOR TO ORDERING AND INSTALLATION. THIS CONTRACTOR IS TO PROVIDE ALL TRADES WITH THE MOST CURRENT INFORMATION AT ALL TIMES.

