

KEY NOTES:

- 1 PROVIDE FLOOR MOUNTED WATER CLOSET, COLD WATER SUPPLY LINE, SUPPLY SHUT OFF VALVE, SANITARY PIPING, & VENT PIPING.
- 2 PROVIDE LAVATORY, SUPPORTS, DOMESTIC WATER SUPPLY LINES, SUPPLY SHUT OFF VALVES, P-TRAP, SANITARY PIPING, & VENT PIPING.
- 3 PROVIDE ADA SHOWER WITH HEAD AND VALVE ASSEMBLY, COLD & HOT WATER SUPPLY LINES, & SUPPLY SHUT OFF VALVES.
- 4 SAWCUT FLOOR ALONG NEW SANITARY LOCATION BACK TO POINT OF CONNECTION, FOR INSTALLATION OF NEW PIPE.
- 5 PROVIDE WASHING MACHINE RECEPTOR BOX, DOMESTIC WATER SUPPLY LINES, SUPPLY SHUT OFF VALVES, P-TRAP, SANITARY PIPING, & VENT PIPING.
- 6 PROVIDE CONCEALED SPRINKLER HEAD AND CONNECT TO NEAREST SPRINKLER SYSTEM MAIN 2" OR LARGER.
- 7 PRIOR TO TRENCHING, PLUMBING CONTRACTOR TO VERIFY DEPTH OF TRENCH FOR APPROPRIATE PITCH FOR NEW SANITARY PIPING.
- 8 PROVIDE LINEAR DRAIN AT SHOWER ENTRY. GRIND DOWN SLAB AS REQUIRED TO ACCOMMODATE DRAIN INSTALL. GRATE SHOULD BE FLUSH WITH FINISHED FLOOR.

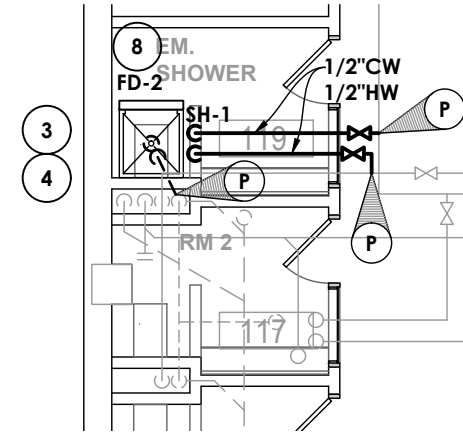

1 EMERGENCY SHOWER PLUMBING NEW WORK
P201 SCALE: 1/8" = 1'-0"

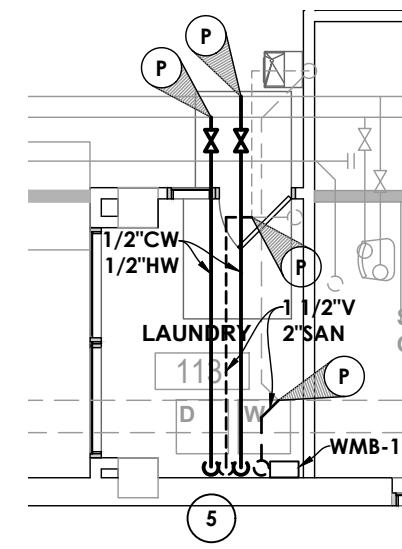

2 LAUNDRY 113 PLUMBING NEW WORK
P201 SCALE: 1/8" = 1'-0"

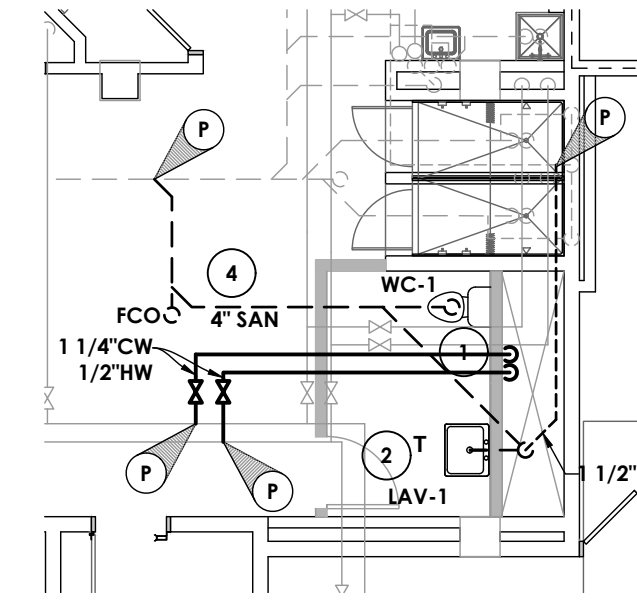

3 NEW TOILET ROOM PLUMBING NEW WORK
P201 SCALE: 1/8" = 1'-0"

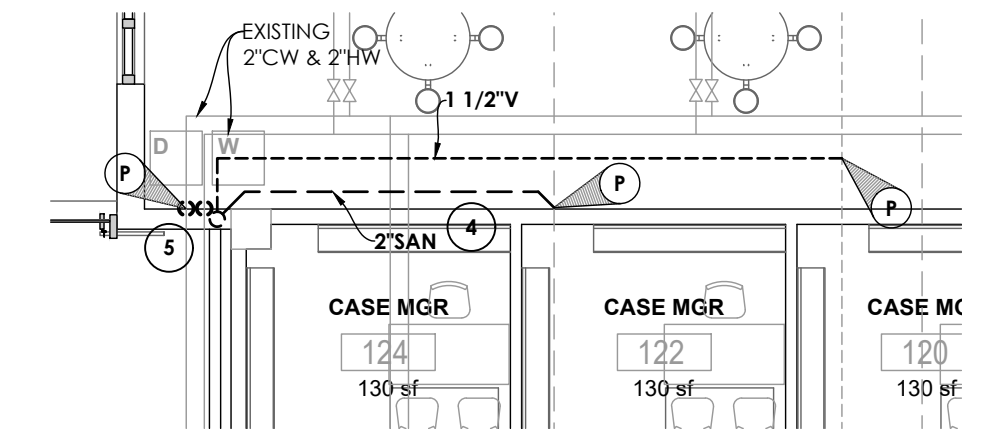

4 LAUNDRY PLUMBING NEW WORK
P201 SCALE: 1/8" = 1'-0"

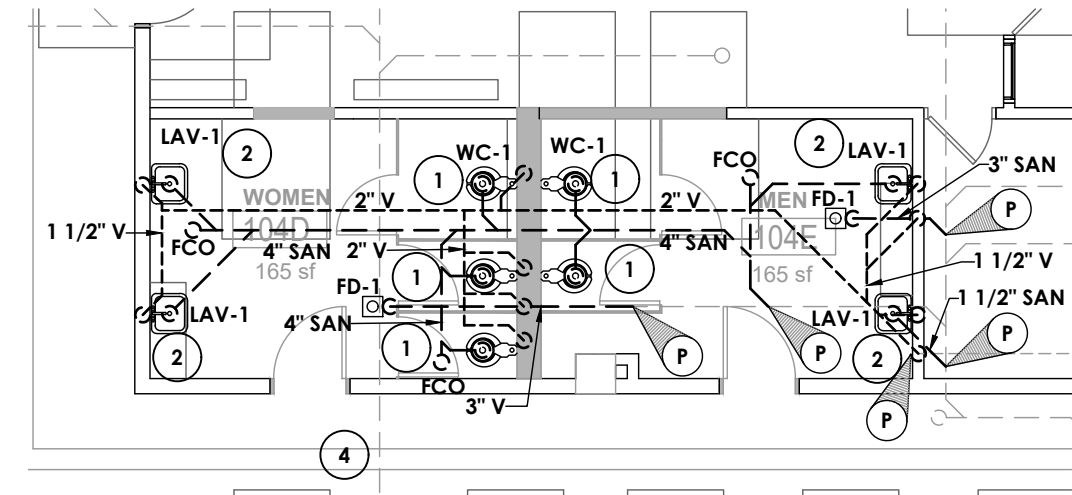

5 104D & 104E SAN & VENT NEW WORK
P201 SCALE: 1/8" = 1'-0"

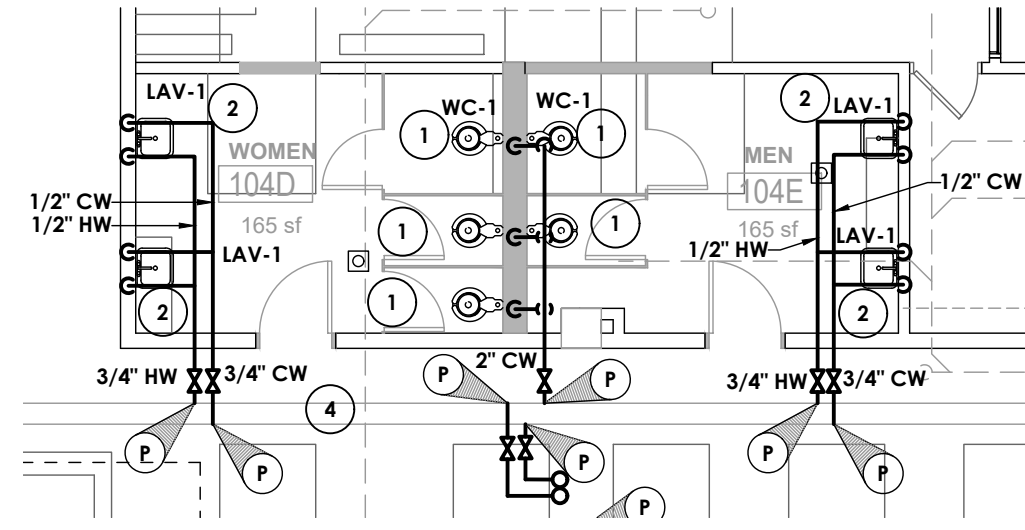

6 104D & 104E DOMESTIC WATER NEW WORK
P201 SCALE: 1/8" = 1'-0"

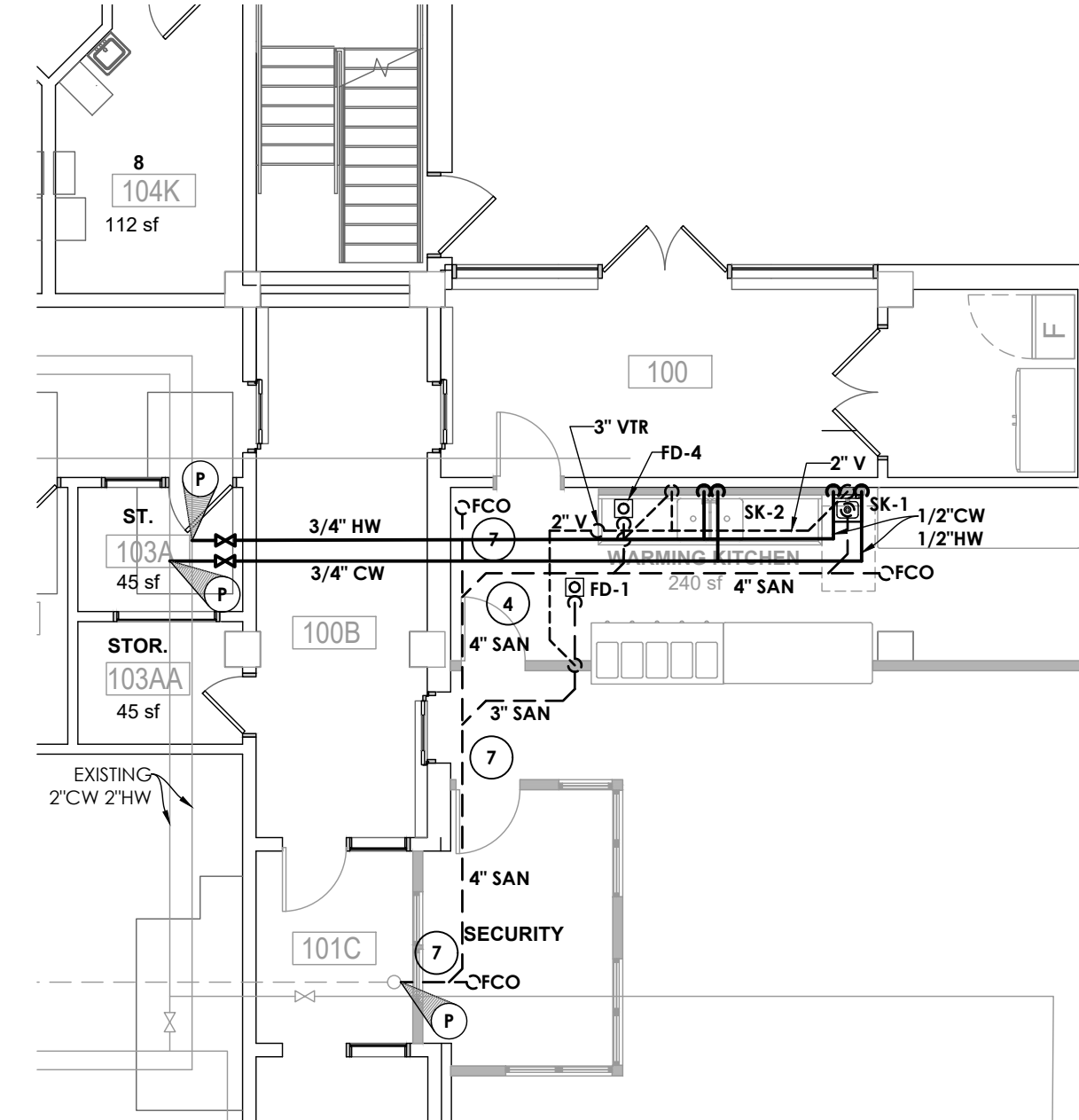

7 WARMING KITCHEN PLUMBING NEW WORK
P201 SCALE: 1/8" = 1'-0"

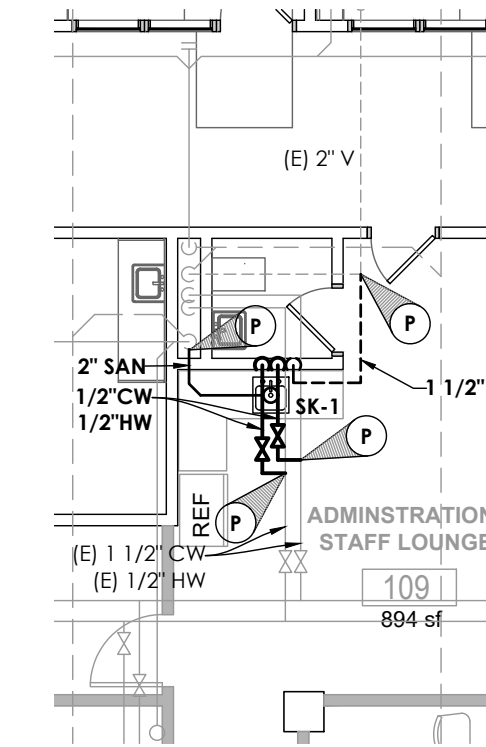

8 ADMIN/STAFF LOUNGE NEW WORK
P201 SCALE: 1/8" = 1'-0"

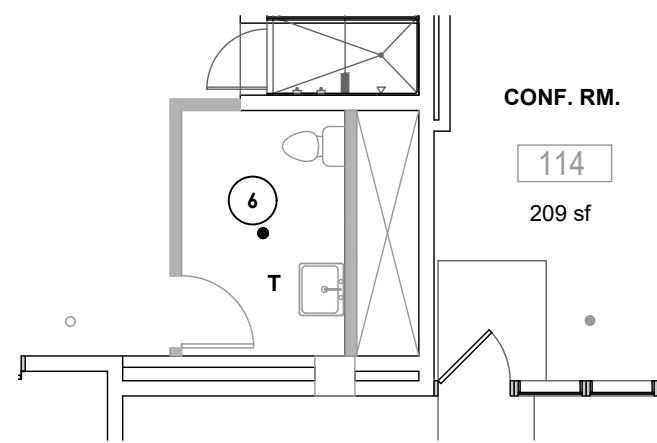

9 NEW 1ST FLOOR TOILET ROOM PLUMBING NEW WORK
P201 SCALE: 1/8" = 1'-0"

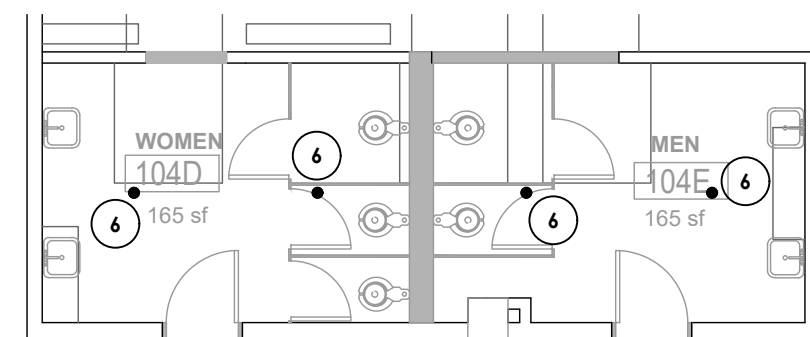

10 104D & 104E DOMESTIC WATER NEW WORK
P201 SCALE: 1/8" = 1'-0"

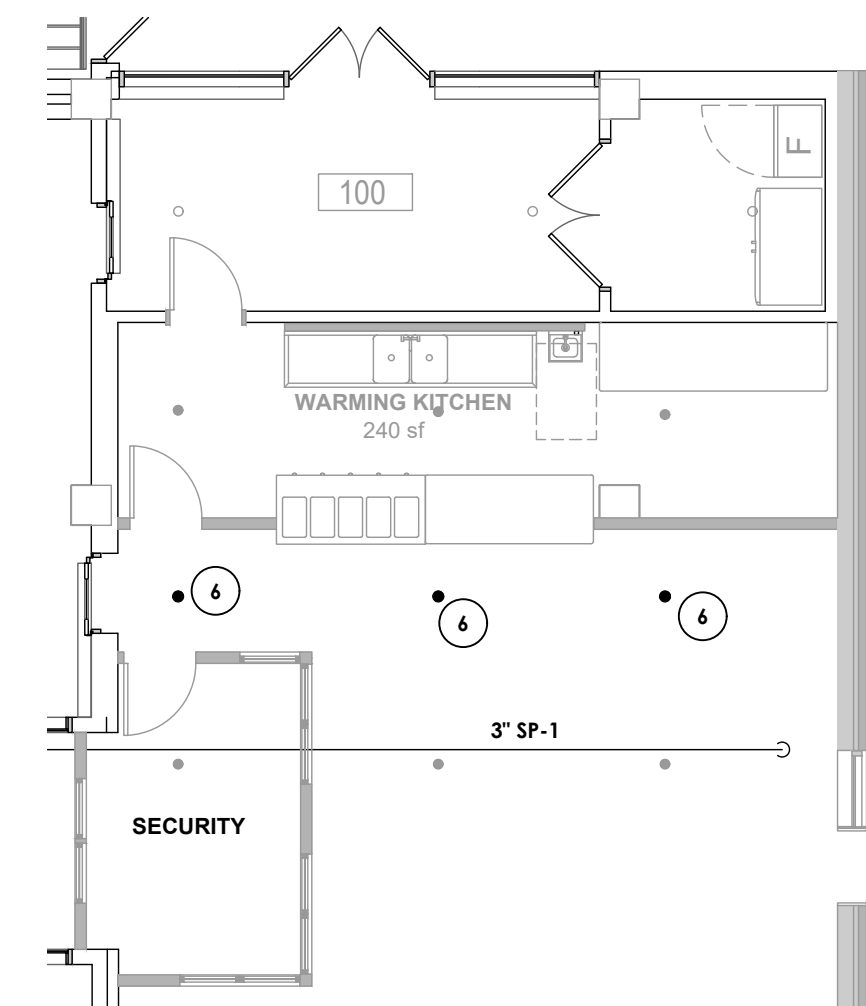

11 WARMING KITCHEN PLUMBING NEW WORK
P201 SCALE: 1/8" = 1'-0"

Submissions

No.	Description	Date

© TINKELMAN ARCHITECTURE PLLC | 2023
ALL RIGHTS RESERVED. NO PART OF THIS DRAWING OR ANY PORTION THEREOF IS TO BE REPRODUCED OR TRANSMITTED IN ANY FORM OR BY ANY MEANS, ELECTRONIC OR MECHANICAL, INCLUDING PHOTOCOPYING, RECORDING, OR BY ANY INFORMATION STORAGE AND RETRIEVAL SYSTEM, WITHOUT THE WRITTEN PERMISSION OF THE ARCHITECT. UNAUTHORIZED REPRODUCTION OR MODIFICATION TO THIS DRAWING BEARING THE SEAL OF A LICENSED ARCHITECT IS A VIOLATION OF SECTION 208 SUBSECTION 2 OF THE NEW YORK STATE EDUCATION LAW.